



for a greener tomorrow



**MITSUBISHI
ELECTRIC**

Changes for the Better

FACTORY AUTOMATION

INVERTER OPTION CATALOG



GLOBAL IMPACT OF MITSUBISHI ELECTRIC



Through Mitsubishi Electric's vision, "Changes for the Better" are possible for a brighter future.

Changes for the Better

We bring together the best minds to create the best technologies. At Mitsubishi Electric, we understand that technology is the driving force of change in our lives. By bringing greater comfort to daily life, maximizing the efficiency of businesses and keeping things running across society, we integrate technology and innovation to bring changes for the better.

Mitsubishi Electric is involved in many areas including the following

Energy and Electric Systems

A wide range of power and electrical products from generators to large-scale displays.

Electronic Devices

A wide portfolio of cutting-edge semiconductor devices for systems and products.

Home Appliance

Dependable consumer products like air conditioners and home entertainment systems.

Information and Communication Systems

Commercial and consumer-centric equipment, products and systems.

Industrial Automation Systems

Maximizing productivity and efficiency with cutting-edge automation technology.

Option lineup	4
Connection example	6
Option list	6
Plug-in option (control function expansion/additional I/O)	9
Plug-in option (for communication)	13
Control terminal option	16
Dedicated cable option	20
Operation panel option	22
Software	24
Reactor	26
Braking option	28
Noise filter	39
Output filter	44
Structure option	46
FR series manual controller/speed controller	52
Other options	57

A Wide Variety of Options Which Improve Such as Installation Attachments, Are

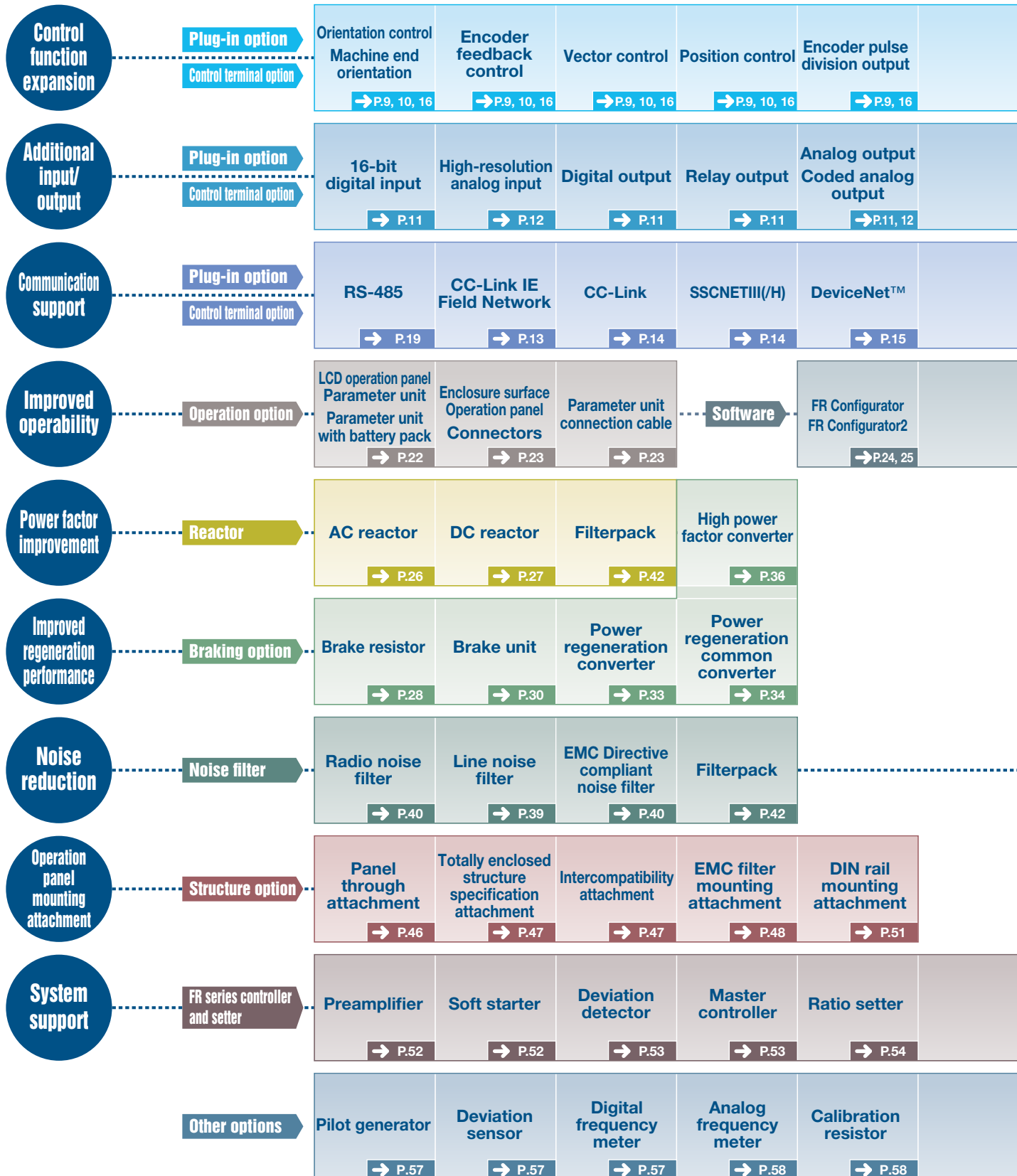

Function and Performance, Available for the FR Series Lineup.

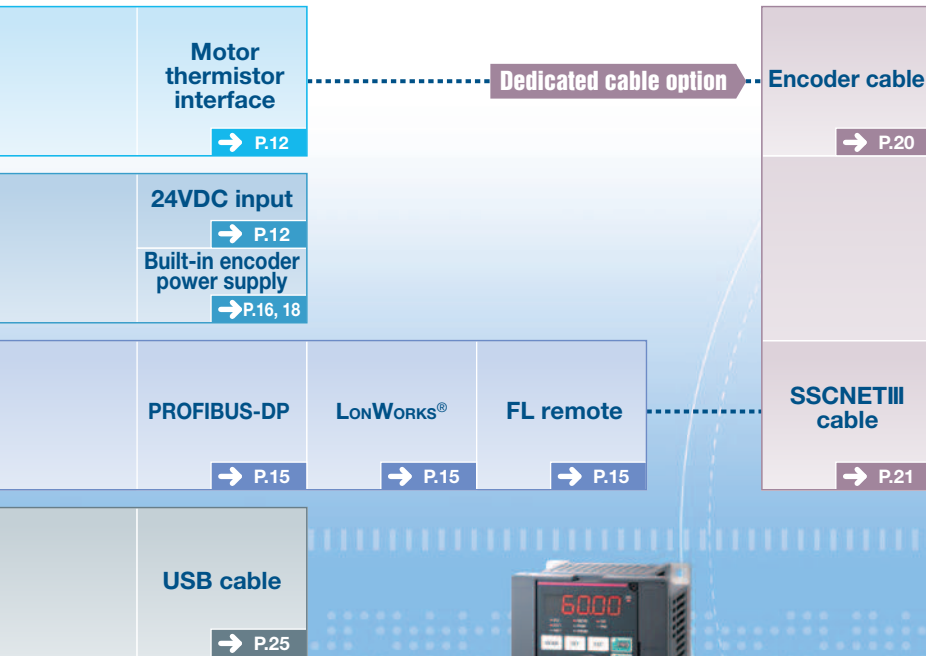

800 series inverters



700 series inverters



Output filter

Surge voltage suppression filter

→ P.44

Sine wave filter

→ P.45

Remote speed setter

→ P.54

Speed detector

→ P.55

DC tach. follower

→ P.55

Three speed selector

→ P.56

Manual controller with frequency meter

→ P.56

Frequency setting potentiometer
Pointer scale
Knob

→ P.59

Connection example

Connection example

This diagram shows the connection of main optional devices with the inverter. All devices in the connection diagram below are not necessarily connected. Select necessary options referring to the table below and descriptions.

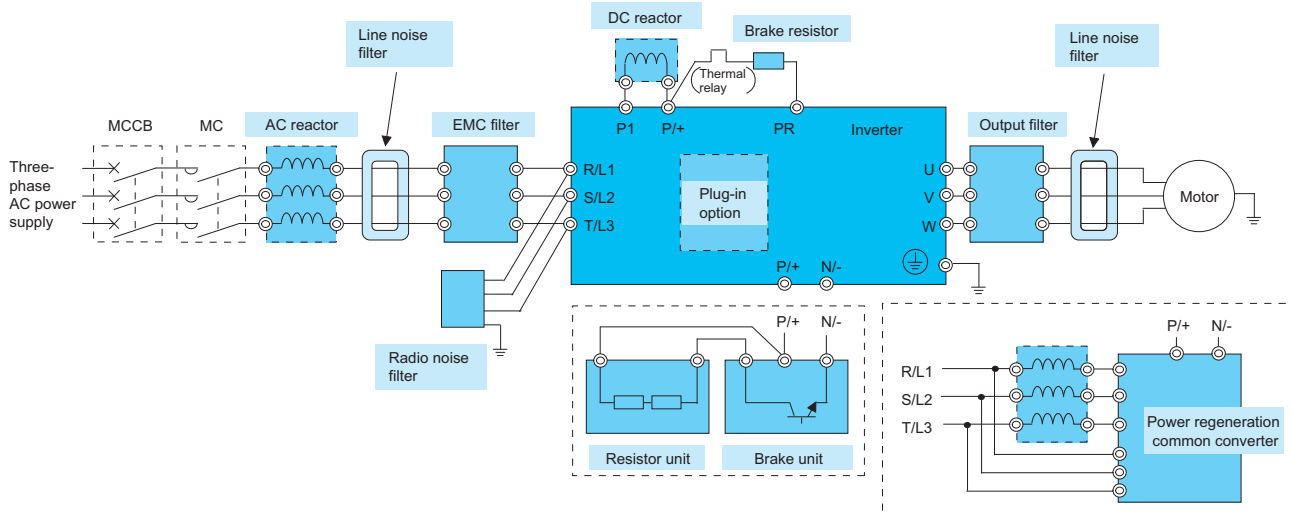

Reactor	Noise filter		Braking unit			Output filter	Plug-in option
	AC reactor DC reactor	Line noise filter Radio noise filter	EMC filter	Brake resistor	Brake unit Resistor unit		
Use when power harmonic measures are required, the power factor is to be improved or the inverter is installed under a large power supply system.	Use to reduce the electromagnetic noise generated from the inverter.	Use this EMC filter to comply with the EU EMC Directive.	Increases the braking capability of the inverter which has a built-in brake transistor.	Increases the braking capability more than the brake resistor. The inverter without a built-in brake transistor can be connected.	Returns regeneration energy to the power supply, enabling continuous regeneration operation. A high power factor converter whose power factor is 1 is available.	Limits surge voltage supplied to the motor terminal.	Mounts to the inverter to expand functions and make communication.

Option list

O: Available x: Not available

Name	Type	Applicable inverter							Refer to Page
		FR-A800	FR-A800 Plus	FR-F800	FR-E700	FR-F700PJ	FR-D700	FR-A701	
Plug-in option (control function expansion, additional input/output)									
Orientation control Encoder feedback control Vector control	FR-A8AP	O	O	x	x	x	x	x	9
	FR-A8APR	O	O	x	x	x	x	x	9
	FR-A7AP	x	x	x	x	x	x	O	9
Orientation control Encoder feedback control Vector control Position control Encoder pulse division output	FR-A8AL	O	O	x	x	x	x	x	9
	FR-A7AL	x	x	x	x	x	x	O	9
16-bit digital input	FR-A8AX	O	O	O	x	x	x	x	11
	FR-A7AX	x	x	x	O (E kit type)	x	x	O	11
Analog output (2 terminals) Digital output (7 terminals)	FR-A8AY	O	O	O	x	x	x	x	11
	FR-A7AY	x	x	x	O (E kit type)	x	x	O	11
Relay output (3 terminals)	FR-A8AR	O	O	O	x	x	x	x	11
	FR-A7AR	x	x	x	O (E kit type)	x	x	O	11
Coded analog output High-resolution analog input Motor thermistor interface	FR-A8AZ	O	O	x	x	x	x	x	12
	FR-A7AZ	x	x	x	x	x	x	O	12
24VDC input	FR-E7DS	x	x	x	O (for the FR-E700-SC only)	x	x	x	12

Option list

O: Available x: Not available

Name	Type	Applicable inverter							Refer to Page
		FR-A800	FR-A800 Plus	FR-F800	FR-E700	FR-F700PJ	FR-D700	FR-A701	
Plug-in option (for communication)									
RS-485	PU connector (inverter)	Equipped as standard	Equipped as standard	Equipped as standard	Equipped as standard *1	Equipped as standard	Equipped as standard	Equipped as standard	—
	Dedicated terminal (inverter)	Equipped as standard	Equipped as standard	Equipped as standard	FR-E7TR	x	x	Equipped as standard	—
USB	USB host	A connector	Equipped as standard	Equipped as standard	Equipped as standard	x	x	x	—
	USB device	B connector	x	x	x	x	x	x	Equipped as standard
		Mini B connector	Equipped as standard	Equipped as standard	Equipped as standard	Equipped as standard	x	x	—
CC-Link IE Field Network	FR-A8NCE	O *2	O	O	x	x	x	x	13
	FR-A7NCE	x	x	x	x	x	x	O	13
	Dedicated inverter	FR-A800-GF	x	x	x	x	x	x	13
CC-Link	FR-A8NC	O *2	O	O	x	x	x	x	14
	FR-A7NC	x	x	x	O (E kit type)	x	x	O	14
	Dedicated inverter	x	x	x	FR-E700-NC	x	x	x	14
SSCNETIII(/H)	FR-A8NS	O *2	O *3	x	x	x	x	x	14
SSCNETIII	FR-A7NS	x	x	x	x	x	x	O	14
DeviceNet™	FR-A8ND	O *2	O	O	x	x	x	x	15
	FR-A7ND	x	x	x	O (E kit type)	x	x	O	15
PROFIBUS-DP	FR-A8NP	O *2	O	O	x	x	x	x	15
	FR-A7NP	x	x	x	O (E kit type)	x	x	O	15
LONWORKS®	FR-A7NL	x	x	x	O (E kit type)	x	x	O	15
FL remote	FR-A8NF	O *2	O *3	O	x	x	x	x	15
	FR-A7NF	x	x	x	x	x	x	O	15
	Dedicated inverter	x	x	x	FR-E700-NF	x	x	x	15
Control terminal option									
Vector control terminal block	FR-A8TP	O	O	x	x	x	x	x	16
Screw terminal block	FR-A8TR	O	O	O	x	x	x	x	17
12V control circuit terminal block with encoder power supply	FR-A7PS	x	x	x	x	x	x	O	18
RS-485 2-port terminal block	FR-E7TR	x	x	x	O (for models with the standard control circuit terminal specification only)	x	x	x	19
Dedicated cable option									
Encoder cable	FR-V7CBL[]	O	O	x	x	x	x	O	20
	FR-JCBL[]	O	O	x	x	x	x	O	20
SSCNET III cable	MR-J3BUS[M-]	x	x	x	x	x	x	O	21
Operation option									
LCD operation panel	FR-LU08	O	O	O	x	x	x	x	22
Parameter unit	FR-PU07	O	O	O	O *1	O	O	O	22
	FR-PU07BB	O	O	O	O *1	x	x	x	22
Enclosure surface operation panel	FR-PA07	x	x	x	O	O	O	x	23
Parameter unit connection cable	FR-CB20[]	O	O	O	O	O	O	O	23
Operation panel connection connector	FR-ADP	O	O	O	x	x	x	O	23
Software									
FR Configurator2	SW1DND-FRC2	O	O	O	x	x	x	x	24
FR Configurator	FR-SW3-SETUP-WE	x	x	x	O *4	O	O	O	25
USB cable	MR-J3USBCBL3M	O	O	O	O	x	x	x	25
Reactor									
AC reactor	FR-HAL	O	O	O	O	O	O	x	26
DC reactor	FR-HEL	O	O	O	O	O	O	x	27
Braking option									
Brake resistor	MRS, MYS	x	x	x	O *5	O *5	O *5	x	28
High-duty brake resistor	FR-ABR	O *5	O *5	x	O *5	O *5	O *5	x	28
Brake unit	FR-BU2	O *6	O *6	O *6	O *6	O *6	O *6	x	30
	Resistor	GRZG	O	O	O	O	O	x	30
		Resistor unit	FR-BR	O	O	O	O	O	x
	MT-BR5	O	O	O	x	x	x	30	
Power regeneration common converter	FR-CV	O	O	O	O	O	O	x	34
	Dedicated, standalone reactor	FR-CVL	O	O	O	O	O	x	34
Power regeneration converter	MT-RC	O	O	O	x	x	x	x	33
High power factor converter	FR-HC2	O	O	O	O	O	O	x	36

Option list

○: Available ×: Not available

Name	Type	Applicable inverter							Refer to Page
		FR-A800	FR-A800 Plus	FR-F800	FR-E700	FR-F700PJ	FR-D700	FR-A701	
Noise filter									
Line noise filter	FR-BSF01	○ *7	○ *7	○ *7	○	○	○	○	39
	FR-BLF	○ *7	○ *7	○ *7	○	○	○	○	39
Radio noise filter	FR-BIF	Corresponding filter is built-in	Corresponding filter is built-in	Corresponding filter is built-in	○	○	○	○	40
EMC Directive compliant EMC filter	Built-in filter	Standard equipped (2nd Environment)			×	×	×	×	—
	SF□□	×	×	×	○	×	○	○	40
	FR-E5NF	×	×	×	○	○	○	×	40
	FR-S5NFSA	×	×	×	○	×	○	×	40
Filterpack (DC reactor/noise filter)	FR-BFP2	×	×	×	○	○ *8	○	×	42
Output filter									
Surge voltage suppression filter	FR-ASF	○ *9	○ *9	○ *9	○	○ *10	○	○ *9	44
	FR-BMF	○ *9	○ *9	○ *9	○	○ *10	○	○ *9	44
Sine wave filter	Reactor	MT-BSL(-HC)	○ *11	○ *11	○ *11	×	×	×	45
	Capacitor	MT-BSC	○ *11	○ *11	○ *11	×	×	×	45
Structure option									
Panel through attachment	FR-A8CN	○	○	○	×	×	×	×	46
	FR-E7CN	×	×	×	○	○	○	×	46
Totally-enclosed structure attachment	FR-E7CV	×	×	×	○ *12	×	×	×	47
Control circuit terminal block intercompatibility attachment	FR-A8TAT	○	○	○	×	×	×	×	47
Intercompatibility attachment	FR-AAT	○	○	○	○	○	○	×	48
	FR-A5AT	○	○	○	○	○	○	×	48
	FR-E7AT	×	×	×	○	×	×	×	48
	FR-F8AT	×	×	○	×	×	×	×	48
EMC filter installation attachment	FR-E5T	×	×	×	○	○	○	×	48
DIN rail installation attachment	FR-UDA	×	×	×	○ *13	○ *13	○ *13	×	51
FR series manual controller/speed controller									
Preamplifier	FR-FA	○	○	○	○	○	○	○	52
Soft starter	FR-FC	○	○	○	○	○	○	○	52
Deviation detector	FR-FD	○	○	○	○	○	○	○	53
Master controller	FR-FG	○	○	○	○	○	○	○	53
Ratio setter	FR-FH	○	○	○	○	○	○	○	54
Motorized speed setter	FR-FK	○	○	○	○	○	○	○	54
Speed detector	FR-FP	○	○	○	○	○	○	○	55
DC tach. follower	FR-AL	○	○	○	○	○	○	○	55
Three speed selector	FR-AT	○	○	○	○	○	○	○	56
Manual controller	FR-AX	○	○	○	○	○	○	○	56
Other options									
Pilot generator	QVAH-10	○	○	○	○	○	○	○	57
Deviation sensor	YVGC-500W-NS	○	○	○	○	○	○	○	57
Analog frequency meter	YM206NRI 1mA	○	○	○	○	○	○	○	58
Calibration resistor	RV24YN 10kΩ	○	○	○	○	○	○	○	58
Frequency setting potentiometer	WA2W 1kΩ	○	○	○	○	○	○	○	59

- *1 PU connector is disabled for the FL remote communication model and the CC-Link communication model.
- *2 The option is not compatible with the FR-A800-GF.
- *3 The option is not compatible with the FR-A800-R2R.
- *4 FR Configurator is not compatible with FL remote communication models.
- *5 Only models with a built-in brake transistor can be used.
- *6 For the 200V class 0.2K or lower, 400V class 1.5K or lower, they cannot be used in combination with a brake unit.
- *7 For the 55K or lower, a corresponding appliance is built-in on the input side.
- *8 Filterpack (FR-BFP2) is enclosed for the FR-F7□0PJ-□□K inverters.
- *9 The filter can be used under V/F control or Advanced magnetic flux vector control.
- *10 The filter cannot be used during IPM motor control.
- *11 The filter can be used under V/F control.
- *12 The option is compatible with the FR-E720-0.1K to 7.5K only.
- *13 The option is compatible with the models with the 3.7kW or lower capacity.

Plug-in option (control function expansion/additional I/O)

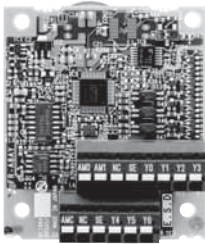

800 series plug-in option example: FR-A8AY

This option can be mounted in the 800 series inverter. Up to three options can be connected. (The number of connectable options differs by the model.)

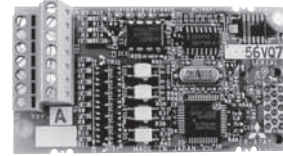

700 series plug-in option example: FR-A7AY

This option can be mounted in the 700 series inverter. Up to three cards are connectable for the FR-A701 and only one for the E700. The FR-E700 has "E kit" in the end of the name and sold as a package set with a dedicated front cover, etc.

Two or more of the same plug-in options cannot be connected.

Orientation control/encoder feedback control/vector control

FR-A8AP, FR-A8APR A800 A800 Plus
FR-A7AP A701

Orientation control/encoder feedback control/vector control/position control/encoder pulse division output/machine end orientation control

FR-A8AL A800 A800 Plus
FR-A7AL A701

Option		FR-A8AP, FR-A8AL, FR-A7AP, FR-A7AL	FR-A8APR
Interface		Encoder	Resolver
Control method	V/F control (orientation control, encoder feedback control)	Induction motor	Induction motor
	Advanced magnetic flux vector control (orientation control, encoder feedback control)	Induction motor	Induction motor
	Vector control	Induction motor	Induction motor or PM motor

Only one of the above options can be used at a time.

When multiple options are connected to the same inverter, the priorities of the options are defined as follows: FR-A8APR > FR-A8AL (FR-A7AL) > FR-A8AP (FR-A7AP).

Orientation control	The inverter can adjust the stop position (Orientation control) using an encoder (resolver) attached to a place such as the main shaft of the machine.
Encoder feedback control	Under V/F control or Advanced magnetic flux vector control, the inverter output frequency is controlled so that the motor speed is constant to the load variation by detecting the motor speed with the encoder (resolver) to perform feedback to the inverter.
Vector control	Full-scale vector control operation can be performed using an induction motor with encoder or an induction or PM motor with resolver.
Position control	Position control can be performed by pulse train input.
Encoder pulse division output	Pulse input of encoder connected to the inverter is divided and output from the option terminal.

Plug-in option (control function expansion/additional I/O)

<<FR-A8AP, FR-A8AL, FR-A7AP, FR-A7AL>>

●Specifications

Function	Description		
Orientation control	Repeated positioning accuracy	±1.5°	
	Permissible speed	Encoder-mounted shaft speed (6000r/min with 1024 pulse encoder) The motor and encoder-mounted shaft should be coupled with a speed ratio of 1 to 1.	
Encoder feedback control	Speed variation ratio	±0.1% (to the speed 3600r/min)	
Vector control	Speed control	Speed control range	1:1500 (both driving/regeneration *1)
		Speed variation ratio	±0.01% (to the speed 3000r/min)
		Speed response	300rad/s (to the analog command input) Note that the internal response is 600rad/s (with model adaptive speed control)
	Torque control	Torque control range	1:50
		Absolute torque accuracy	±10% *2
		Repeated torque accuracy	±5% *2
	Position control (available for FR-A8AL, FR-A7AL)	Pulse input type	Forward rotation pulse train + reverse rotation pulse train Pulse train + sign A phase pulse train + B phase pulse train
		Repeated positioning accuracy	±1.5° (motor shaft end)
		Power supply	24V power supply output for interface driver is provided
		Maximum input pulse frequency	Differential line receiver: 500kpps Open collector: 200kpps
Encoder pulse division output (available for FR-A8AL, FR-A7AL)	Output circuit method	Open collector and differential line driver	
	Permissible load	Open collector output: 24VDC, max 50mA Differential line driver output: 0.1A	
Machine end orientation control (available for FR-A8AL, FR-A7AL)	Repeated positioning accuracy	±1.5°	
	Permissible speed	Encoder-mounted shaft speed (6000r/min)	

- *1 Regeneration unit (option) is necessary for regeneration.
- *2 With online auto tuning (adaptive magnetic flux observer), dedicated motor, rated load
- *3 FR-A7AL uses two option connectors of an inverter. When using FR-A7AL, only one more built-in option can be used.

(Applicable machine end encoder)

- Differential line driver or complementary
- 1000P/R to 4096P/R
- A separate power supply of 5V/12V/15V/24V is necessary according to the encoder power specification.

●Connection diagram (Sink logic)

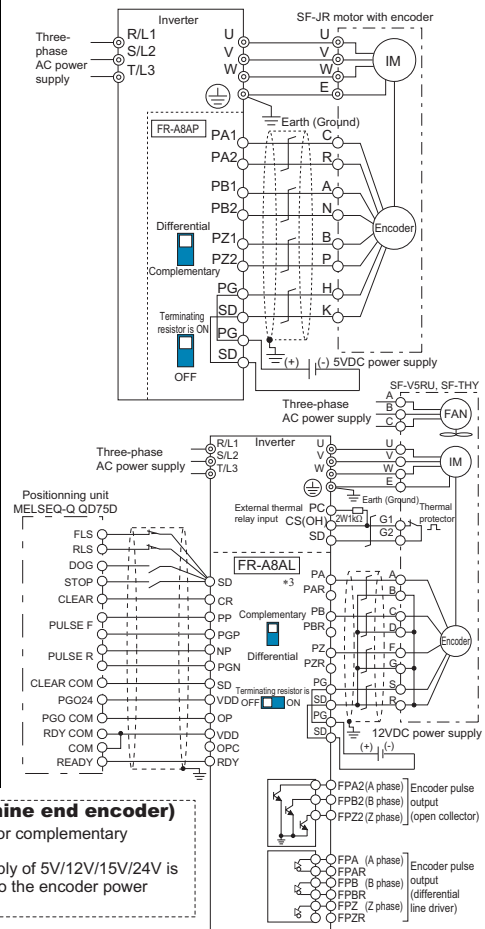

<<FR-A8APR>>

●Specifications

Function	Description		
Orientation control	Repeated positioning accuracy	±1.5° Depends on the load torque, moment of inertia of the load or orientation, creep speed, position loop switching position, etc.	
	Permissible speed	Resolver-mounted shaft speed (6000r/min). The drive shaft and resolver-mounted shaft must be coupled directly or via a belt without any slip. Gear changing shafts cannot be applied.	
Resolver (encoder) feedback control	Speed variation ratio	±0.1% (100% means 3600r/min)	
Vector control	Speed control	Speed control range	1:1500 (both driving/regeneration*1)
		Speed variation ratio	±0.01% (100% means 3000r/min)
		Speed response	20Hz (40Hz during fast-response operation)
		Maximum speed	400Hz
	Torque control	Torque control range	1: 50
		Absolute torque accuracy	±10% *2
		Repeated torque accuracy	±5% *2
	Position control	Repeated positioning accuracy	±1.5° (at motor shaft end)
		Maximum input pulse frequency	100kpps (Terminal JOG)
		Positioning feedback pulse	4096 pulses/rev
Electronic gear setting		1/50 to 20	
Recommended resolver	In-position width	0 to 32767 pulses	
	Error excess	0 to 400k pulses	
TS2640N321E64 manufactured by Tamagawa Seiki Co., Ltd. or equivalent			

- *1 Regeneration unit (option) is necessary for regeneration
- *2 With online auto tuning (adaptive magnetic flux observer), dedicated motor, rated load

●Connection diagram

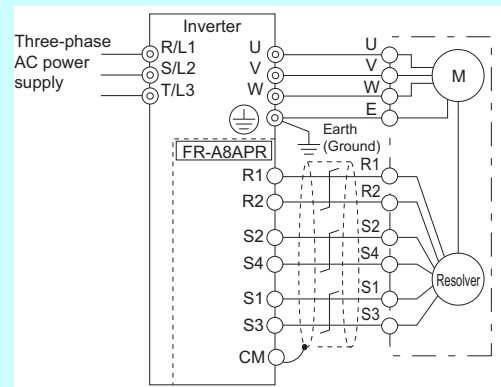

Plug-in option (control function expansion/additional I/O)

16-bit digital input

FR-A8AX (A800) (A800 Plus) (F800)
FR-A7AX (A701) FR-A7AX E kit (E700)

Digital input Frequency setting of the inverter can be performed using a digital signal such as BCD code or binary code from controller.

●Specifications

Function	Description	
Digital input	Digital input signal type	BCD code 3 digits or 4 digits Binary 12 bits or binary 16 bits
	Input specifications	Contact signal or open collector input

●Connection diagram

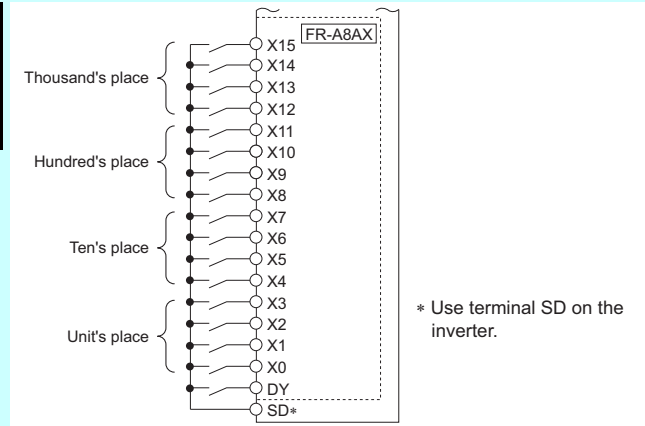

Analog output/digital output

FR-A8AY (A800) (A800 Plus) (F800)
FR-A7AY (A701) FR-A7AY E kit (E700)

Digital output Output signal (RUN, SU, etc.) provided with the inverter as standard can be output from the open collector terminal.

Analog output Analog signals such as the output frequency and output current can be output from the voltage output terminal (AM0) and current output terminal (AM1).

●Specifications

Function	Description	
Digital output	Open collector output specifications	Permissible load 24VDC 0.1A
	Circuit logic	Same as the inverter (sink when shipped from factory)
Analog output	Output signal	Voltage output (across terminals AM0-AMC) FR-A8AY: 0 to ±10VDCMAX FR-A7AY: 0 to 10VDCMAX Current output (across terminals AM1-AMC) 0 to 20mADC
	Wiring length	Maximum 10m

●Connection diagram

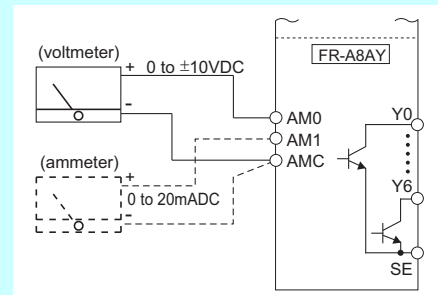

Relay output

FR-A8AR (A800) (A800 Plus) (F800)
FR-A7AR (A701) FR-A7AR E kit (E700)

Relay output You can select any three output signals (RUN, SU, IPF, etc.) available with an inverter as standard, and output them as relay contact (1C) signals.

●Specifications

Function	Description	
Relay output	Contact capacity	AC230V... 0.3A DC30V ... 0.3A

●Connection diagram

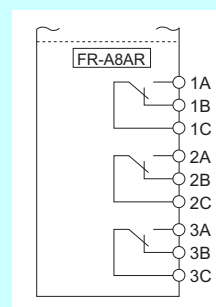

Plug-in option (control function expansion/additional I/O)

Coded analog output/high-resolution analog input/ motor thermistor interface

FR-A8AZ (A800) (A800 Plus)

FR-A7AZ (A701)

- Coded analog output** Outputting 0 to $\pm 10\text{VDC}$ enables output frequency, output voltage, etc. to be monitored with a DC voltage meter.
- High-resolution analog input** Inputting 0 to $\pm 10\text{VDC}$ voltage enables speed command, torque limit command, torque command, etc.
- Motor thermistor interface** When using a dedicated motor with thermistor for vector control (SF-V5RU□□KT), feeding back the motor temperature detected by the motor side thermistor to the inverter can reduce fluctuation of torque generated due to temperature change.

●Specifications

Function	Description	
Coded analog output	Output signal	Voltage output (between terminal DA1 to 5): -10V to $+10\text{VDC}$
High resolution analog input	Resolution	-10V to $+10\text{V}$ /16 bits
	Input resistance	$10\text{k}\Omega$
	Maximum input voltage	$\pm 20\text{VDC}$
Motor thermistor interface	Detectable motor temperature	-50°C to 200°C
	Torque accuracy	$\pm 3\%$

●Connection diagram

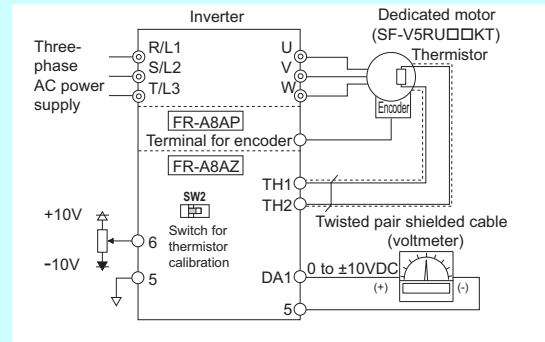

24VDC input

FR-E7DS (E700)

Supports FR-E700-SC only.

Instead of the main circuit power supply, external power can be supplied to an inverter. Connect the 24V external power supply across terminals +24 and SD. The 24V external power supply enables I/O terminal operation, operation panel displays, and control functions even while the inverter's main circuit power supply is OFF. When the main circuit power supply is turned ON, the power supply changes from the 24V external power supply to the main circuit power supply.

●Specifications

Function	Description	
24VDC input	Input voltage	23.5V to 26.5VDC
	Input current	0.7A or lower

●Connection diagram

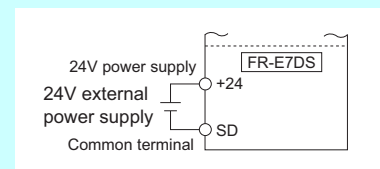

Plug-in option (for communication)

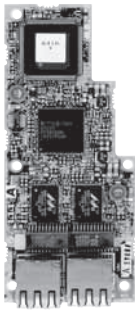

**800 series plug-in option
example: FR-A8NCE**

This option can be mounted in the 800 series inverter. Dedicated inverters are also available in the FR-A800 series.

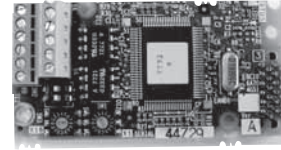

700 series plug-in option example: FR-A7NP

This option can be mounted in the 700 series inverter. The FR-E700 has "E kit" in the end of the name and sold as a package set with a dedicated front cover, etc. Dedicated inverters are also available.

For the communication option, only one option is connectable.

CC-Link IE Field Network communication

FR-A8NCE A800 A800 Plus F800

Dedicated inverter FR-A800-GF A800

FR-A7NCE A701

Gigabit transmission (1 Gbps) enables super-high speed communication.

Network configuration is flexible with different types of topologies.

CC-Link IE Field Network uses widely available Ethernet components, such as Ethernet cables and connectors.

● Specifications

Item	Description			
Type	Inverter plug-in option type, RJ-45 connector connection method			
Power supply	Supplied from the inverter			
Transmission speed	1Gbps			
Communication method	Token passing			
Number of units connected	120 units at max. (64 units when all stations are inverters handling 128-word transmissions.) Different devices can be connected together.			
Maximum distance between nodes	100m			
Maximum number of branches	No upper limit within the same Ethernet system			
Topology	Line, star, ring, or a combination of line and star			
Connection cable	Ethernet cable (IEEE 802.3 1000BASE-T compliant cable or ANSI/TIA/EIA-568-B (Category 5e) compliant shielded 4-pair branched cable)			
Connector	Shielded RJ-45			
Node type	Intelligent device station	Maximum cyclic size (of one node)	RX	64 bits
			RY	64 bits
			RWr	128 words
			RWw	128 words
		Transient transmission	Not available	

Plug-in option (for communication)

CC-Link communication

FR-A8NC (A800) (A800 Plus) (F800)
 FR-A7NC (A701) FR-A7NC E kit (E700)
 Dedicated inverter FR-E700-NC (E700)

High speed communication of 10Mbps maximum is realized. Because the system employs the bus connection method, even if a module system fails due to power off, it will not affect the communication with other normal modules.

●Specifications

Item	Description
Network topology	Bus
Station type	Remote device station
Number of connectable devices	42 units maximum (occupy 1 station/unit), can be shared with other models
Supported version	Ver. 2.00 supported
Communication speed	Selectable from among 156kbps/625kbps/2.5Mbps/5Mbps/10Mbps
Overall extension	1200m/600m/200m/150m/100m (corresponding to the above communication speed)
Connection cable	Twisted pair cable

SSCNET III(H) communication

FR-A8NS (A800) (A800 Plus) (Not compatible with the FR-A800-R2R)
 FR-A7NS (A701)

By communication with the Mitsubishi motion controller, inverter operation (speed control, position control, and torque control under vector control with encoder) and monitoring from the program on the motion controller are enabled. (SSCNET III/H communication is supported by the FR-A8NS only.)

SSCNET III(H), which is optical network, realizes reduction in wiring length, reliability improvement, synchronous control performance improvement, and multi-axis batch control using a motion controller.

When using SSCNET III(H), the FR-A8AP/FR-A7AP or FR-A8AL/FR-A7AL is required as control system of the inverter is vector control with encoder.

●Specifications

Item	SSCNET III	SSCNET III/H
Compatible options	FR-A8NS, FR-A7NS	FR-A8NS
Communication speed	50Mbps for two-way	150Mbps for two-way
Wiring distance between stations	Up to 50m	Up to 100m
Overall length	Up to 800m	Up to 1600m
Selectable calculation cycle	0.444ms, 0.888ms or more	0.222ms, 0.444ms, 0.888ms or more
Number of connectable devices	16 axis maximum	
Connection cable	SSCNET III cable (refer to page 21) MR-J3BUS[M] (0.15m, 0.3m, 0.5m, 1m, 3m): standard code for enclosure MR-J3BUS[M-A] (5m, 10m, 20m): standard cable for outside enclosure MR-J3BUS[M-B] (30m, 40m, 50m): long-distance cable	

There are some restrictions on the SSCNET III communication according to the setting of calculation cycle.

Calculation cycle	Restrictions for the SSCNET III communication
0.222ms	Not applicable.
0.444ms	Up to 8 axes controlled in a system.*1 Set the axis number between 0 to 7 using the axis number switch on the FR-A8NS/FR-A7NS. An inverter set as the axis number between 8 to F cannot be recognized.
0.888ms or more	No restriction.

*1 If this calculation cycle is set for the system requiring 9 axes or more, the calculation cycle of 0.888ms is applied.

DeviceNet™ communication

FR-A8ND (A800) (A800 Plus) (F800)
FR-A7ND (A701) FR-A7ND E kit (E700)

DeviceNet employs CAN (Controller Area Network) and is widely used in the automotive industry.

● Specifications

Item	Description
Network topology	Bus (trunk line · branch line)
Number of connectable devices	64 inverters (including master)
Communication speed	Selectable from among 125kbps/250kbps/500kbps
Overall extension	500m/250m/100m (corresponding to the above communication speed)
Connection cable	DeviceNet standard thick cable or thin cable (5 wire twisted pair cable)

PROFIBUS-DP communication

FR-A8NP (A800) (A800 Plus) (F800)
FR-A7NP (A701) FR-A7NP E kit (E700)

Profibus-DP realizes high speed communication of 12Mbps maximum and is widely used in FA industry such as automotive, conveyance.

● Specifications

Item	Description
Network topology	Bus
Number of connectable devices	126 inverters (including master and repeater)
Communication speed	9.6kbps, 19.2kbps, 93.75kbps/187.5kbps/500kbps, 1.5Mbps/3.0Mbps, 6.0Mbps, 12.0Mbps
Overall extension	1200m/600m/200m/100m (corresponding to the above communication speed)
Connection cable	Profibus communication cable

LONWORKS® communication

FR-A7NL (A701) FR-A7NL Ekit (E700)

Decentralized control without master assures that the whole system will not stop even if any of the station fails. In addition, communication traffic can be restricted.

● Specifications

Item	Description
Network topology	Bus, free topology
Number of nodes occupied	One inverter occupies one node.
Number of connectable devices	64 units maximum including inverters in the same segment
Communication speed	78kbps
Overall extension	Free topology: 500m maximum, bus topology: 2700m maximum
Connection cable	Twisted pair cable

FL remote communication

FR-A8NF (A800) (A800 Plus) (F800) (Not compatible with the FR-A800-R2R)

FR-A7NF (A701)
Dedicated inverter FR-E700-NF (E700)

A high speed communication of 100Mbps is obtained with an Ethernet-based network.

● Specifications

Item	Description
Network topology	Star (connection with a hub in the center), Star bus (connection with multiple hubs)
Number of connectable devices	64 units
Communication speed	10Mbps/100Mbps (auto detection)
Overall extension	2000m (Between node-hub: 100m maximum, between hubs: 100m maximum)
Connection cable	FL-net dedicated cable

Control terminal option

Vector control terminal block

FR-A8TP A800 A800 Plus

Use the option in exchange with standard control circuit terminals. The 24VDC power supply can be used for the encoder of the SF-V5RU.

Control terminal specifications

<<Input signal>>

Function	Terminal symbol	Terminal name	Rated specification
Contact input	DI1 to DI4	Digital input terminal 1 to 4	Input resistance: 4.7kΩ Voltage when contacts are open: 21 to 27VDC Current when contacts are short-circuited: 4 to 6mADC When terminal DI4 is used as a pulse train input terminal: Input resistance: 2kΩ When contacts are short-circuited: 8 to 13mADC
	OH	Thermal protector input	Input resistance: 940Ω Voltage when contacts are open: 21 to 27VDC Current when contacts are short-circuited: 140 to 180mADC
Encoder signal	PA3	Control terminal option / A-phase signal input terminal	Differential line driver/ Complementary
	PAR3	Control terminal option / A-phase inverse signal input terminal	Differential line driver
	PB3	Control terminal option / B-phase signal input terminal	Differential line driver/ Complementary
	PBR3	Control terminal option / B-phase inverse signal input terminal	Differential line driver
	PZ3	Control terminal option / Z-phase signal input terminal	Differential line driver/ Complementary
	PZR3	Control terminal option / Z-phase inverse signal input terminal	Differential line driver
	PG	Encoder power supply terminal (positive side)	—

<<Output signal>>

Function	Terminal symbol	Terminal name	Rated specification
Open collector	DO1 to DO3	Digital output terminal 1 to 3	Open collector output Permissible load: 24 to 27VDC, 0.1A
	SE	Open collector output common	—
Encoder pulse dividing output	FPA5	Control terminal option / Encoder A-phase output terminal	Open collector output Permissible load: 24 to 27VDC, maximum 50mA
	FPB5	Control terminal option / Encoder B-phase output terminal	
	FPZ5	Control terminal option / Encoder Z-phase output terminal	
	FPA4	Control terminal option / Encoder differential A-phase output terminal	Differential line driver output Permissible load: 0.1A
	FPAR4	Control terminal option / Encoder differential A-phase inverse signal output terminal	
	FPB4	Control terminal option / Encoder differential B-phase output terminal	
	FPBR4	Control terminal option / Encoder differential B-phase inverse signal output terminal	
FPZ4	Control terminal option / Encoder differential Z-phase output terminal		
FPZR4	Control terminal option / Encoder differential Z-phase inverse signal output terminal		
Power supply output for encoder	PG24	Encoder power supply terminal (positive side)	24 to 26.4VDC 80mA

Specifications are the same as those of the standard control circuit terminals for the input signals (STF, STR, RES, SD, PC, 10E, 2, 1, 5, and +24) and the output signals (A, B, C, AM, S1, S2, SIC, SO, and SOC).

Terminal layout

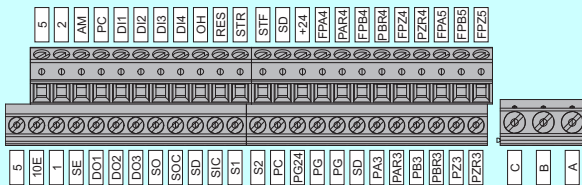

Tightening torque: 0.5N·m to 0.6N·m (terminals A, B, and C)
0.22N·m to 0.25N·m (terminals other than described above)
Small flat-blade screwdriver (Tip thickness: 0.4mm / tip width: 2.5mm)

Terminal connection diagram (sink logic)

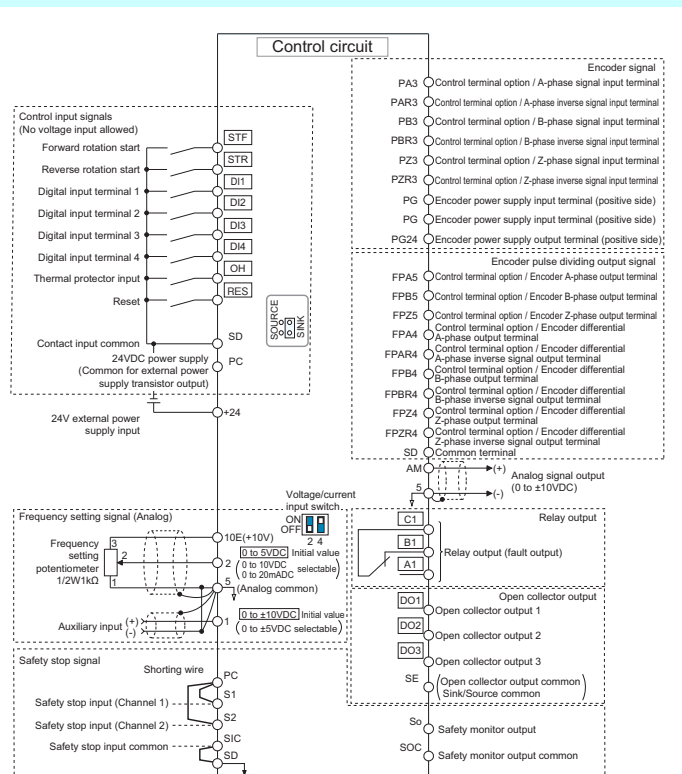

Screw terminal block

FR-A8TR A800 A800 Plus F800

The option replaces the standard control circuit terminal block.

Terminal layout

Terminal screw size: M3.5
Tightening torque: 1.2N·m
Recommended cable gauge: 0.75mm²

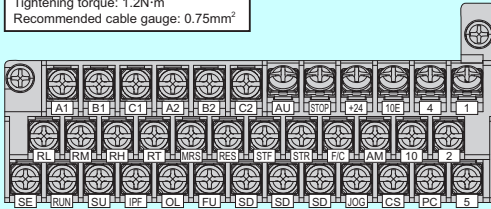

Restrictions for the FR-A8TR

As compared with the standard control circuit terminal block, the FR-A8TR has the following restrictions.

- When the plug-in option FR-A8NC, FR-A8NCE, or FR-A8NS is used, terminals +24, 10E, 4, STOP, and AU of the FR-A8TR cannot be used.
- Because the height is restricted, two wires cannot be wired to upper-row terminals (except for terminals A1, B1, C1, A2, B2, and C2) and middle-row terminals on the terminal block.
- The safety stop function is not available.
- For the connection to terminal 1, use a screwdriver with a diameter of 4 mm or less. To avoid contact with the front cover fixing area, put the screwdriver upright relative to the terminal screw surface.

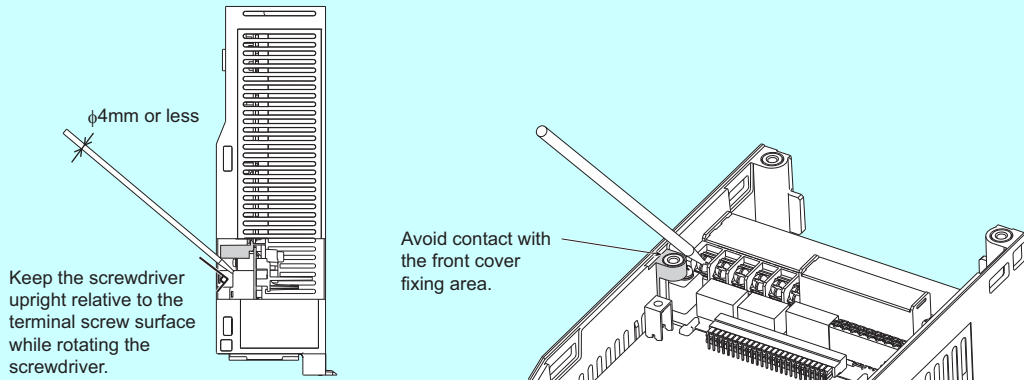

Control terminal option

Control circuit terminal block with 12V encoder power supply FR-A7PS A701

Use the option in exchange with standard control circuit terminals. This option enables the inverter to supply the 12V power source for the encoder.

● Specifications

Terminal Symbol	Terminal Name	Rated Specifications
PG12	Encoder power supply terminal (Positive side)	12VDC±10% Permissible maximum load current 150mA
SD	Contact input common (sink), Power supply ground terminal	Power supply common

The control circuit terminal specifications not shown above are the same as the specifications of the standard terminal block.

● Terminal layout

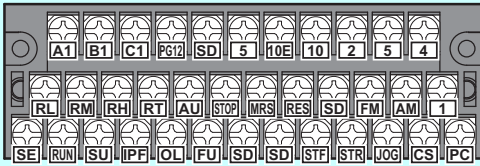

● Main differences and compatibilities with the standard terminal block

Standard Terminal Block	FR-A7PS
Without 12VDC power supply for encoder	With 12VDC power supply for encoder
Two relay contact terminals (terminal A1, B1, C1, A2, B2, C2)	One relay contact terminal (terminal A1, B1, C1)
<i>Pr. 196 ABC2 terminal function selection</i>	The <i>Pr. 196</i> setting is invalid.
One terminal 5	Two terminal 5

● Wiring example of FR-A7AP (Sink logic)

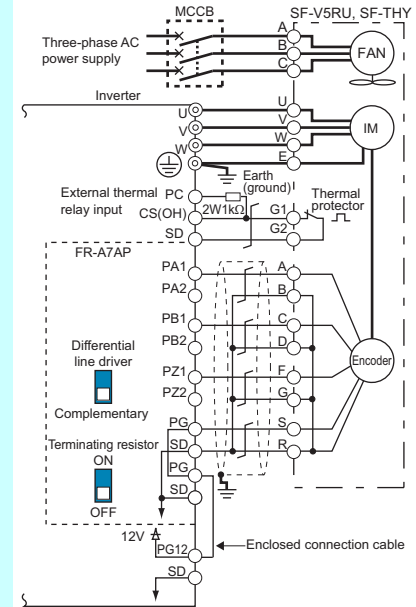

RS-485 2-port terminal block

FR-E7TR E700

Use the option in exchange with standard control circuit terminals. (This option cannot be used simultaneously with the operation panel (FR-PA07) or parameter unit (FR-PU07).) This terminal block enables RS-485 communication. Multi-drop connection can be easily performed with separate input and output terminals.

Control terminal specifications

Terminal Symbol		Terminal Name	Rated Specifications														
RS-485 communication	SDA (2 terminals)	Inverter send+	<table border="1"> <thead> <tr> <th>Item</th> <th>Description</th> </tr> </thead> <tbody> <tr> <td>Communication protocol</td> <td>Mitsubishi inverter protocol (computer link communication), MODBUS[®]RTU protocol</td> </tr> <tr> <td>Conforming standard</td> <td>EIA-485 (RS-485)</td> </tr> <tr> <td>Number of connectable devices</td> <td>32 units maximum</td> </tr> <tr> <td>Communication speed</td> <td>4800/9600/19200/38400 bps</td> </tr> <tr> <td>Communication method</td> <td>Half-duplex system</td> </tr> <tr> <td>Terminating resistor</td> <td>100Ω (valid/invalid can be changed with a terminating resistor switch)</td> </tr> </tbody> </table>	Item	Description	Communication protocol	Mitsubishi inverter protocol (computer link communication), MODBUS [®] RTU protocol	Conforming standard	EIA-485 (RS-485)	Number of connectable devices	32 units maximum	Communication speed	4800/9600/19200/38400 bps	Communication method	Half-duplex system	Terminating resistor	100Ω (valid/invalid can be changed with a terminating resistor switch)
	Item	Description															
	Communication protocol	Mitsubishi inverter protocol (computer link communication), MODBUS [®] RTU protocol															
	Conforming standard	EIA-485 (RS-485)															
Number of connectable devices	32 units maximum																
Communication speed	4800/9600/19200/38400 bps																
Communication method	Half-duplex system																
Terminating resistor	100Ω (valid/invalid can be changed with a terminating resistor switch)																
SDB (2 terminals)	Inverter send-																
RDA (2 terminals)	Inverter receive+																
RDB (2 terminals)	Inverter receive-																
Frequency setting	10	Frequency setting power supply	5.2VDC±0.2V Permissible load current 10mA														
	2	Frequency setting (voltage)/Common terminal	When voltage is input: input resistance 10kΩ±1kΩ Permissible maximum load voltage 20VDC When selected with SG: common terminal														
	4	Frequency setting (current)	When current is input: input resistance 233Ω±5Ω Permissible load current 30mA When voltage is input: input resistance 10kΩ±1kΩ Permissible maximum load voltage 20VDC														
SG	RS-485 communication common, Analog common	Common terminal															

Terminal connection diagram

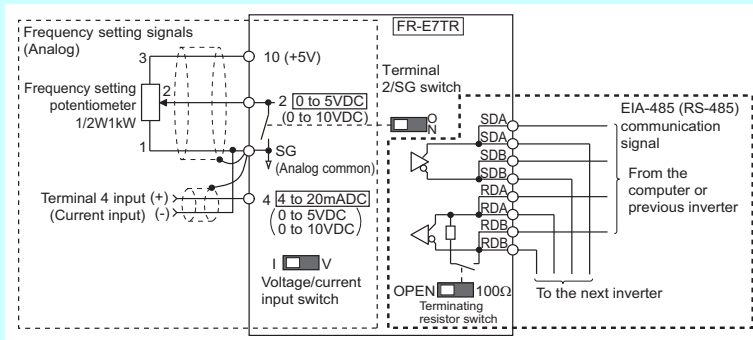

Terminal layout

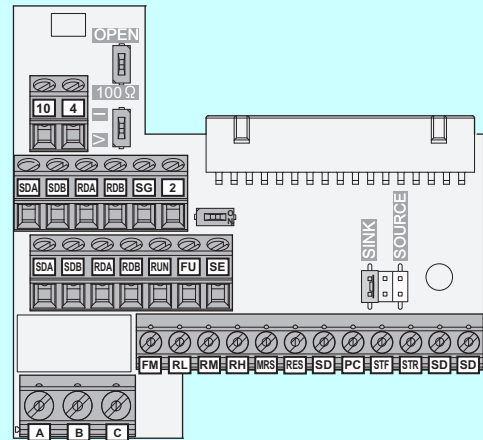

Dedicated cable option

Encoder cable

FR-V7CBL□□ A800 A800 Plus A701

FR-JCBL□□ A701

Dedicated cable for connecting encoder signal from the motor to the inverter.

●Outline dimension drawings, connection diagram

<<FR-V7CBL□□>>

Motor: SF-PR-SC/SF-V5RU

Option: FR-A8AP/FR-A8AL/FR-A8TP/FR-A7AP/FR-A7AL

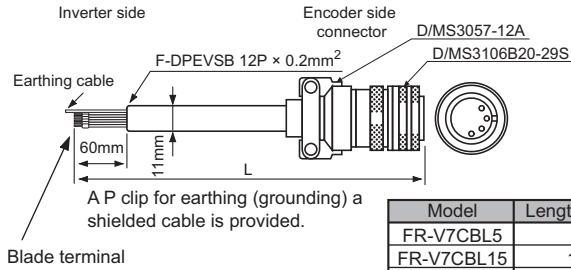

Model	Length L (m)
FR-V7CBL5	5
FR-V7CBL15	15
FR-V7CBL30	30

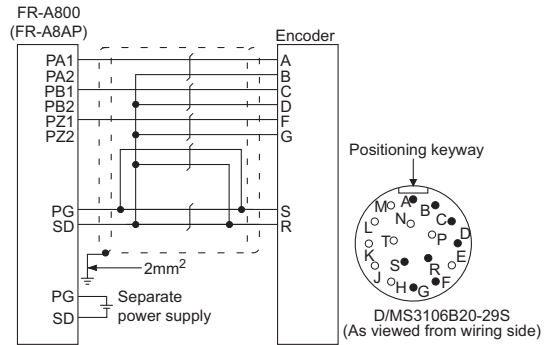

<<FR-JCBL□□>>

Motor: SF-JR with encoder

Option: FR-A8AP/FR-A8AL/FR-A8TP/FR-A7AP/FR-A7AL

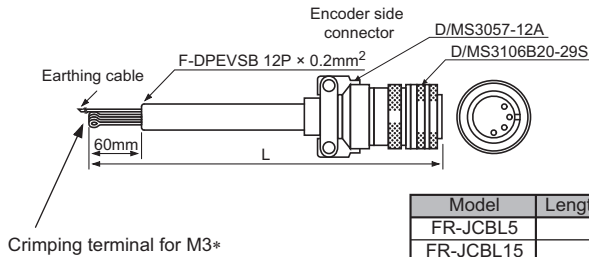

Model	Length L (m)
FR-JCBL5	5
FR-JCBL15	15
FR-JCBL30	30

* Change to blade terminal when used with the FR-A8AP/FR-A8AL/FR-A8TP/FR-A7AP/FR-A7AL.

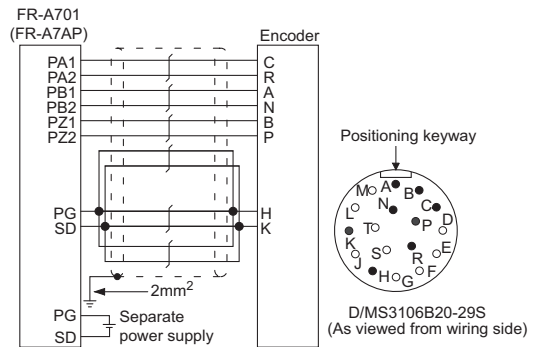

SSCNET III cable MR-J3BUS□M(-A, -B) **A800** **A800 Plus** **A701** (Not compatible with the FR-A800-R2R)

Dedicated cables are available for SSCNET III(H) connection. The cables can be used for the inverter with the following plug-in options.
 800 series: FR-A8NS+FR-A8AP/FR-A8AL
 700 series: FR-A7NS+FR-A7AP/FR-A7AL

●Specifications

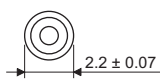
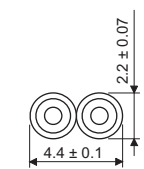
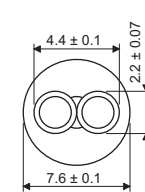
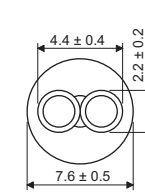
Model*1		MR-J3BUS□M		MR-J3BUS□M-A	MR-J3BUS□M-B
Applications		Standard code for enclosure		Standard cable for outside enclosure	Long distance cable
Flexing life		Standard		Standard	High flexion
Length (m)		0.15	0.3 to 3	5 to 20	30 to 50
Optical cable (code)	Minimum bending radius (mm)*2	25		Reinforced sheath portion of cable: 50 Code section: 25	Reinforced sheath portion of cable: 50 Code section: 30
	Tension strength	70N	140N	420N (Reinforced sheath portion of cable)	980N (Reinforced sheath portion of cable)
	Operating temperature range*3	-40 to 85°C			-20 to 70°C
	Atmosphere	Indoor (avoid direct sunlight) No medium nor oil should be attached			
Appearance (mm)					

*1 □ of model indicates the cable length.

Symbol	015	03	05	1	3	5	10	20	30	40	50
Length (m)	0.15	0.3	0.5	1	3	5	10	20	30	40	50

*2 Make sure to lay the cable with greater radius than the minimum bend radius. Do not press the cable to edges of equipment or others.

*3 This operating temperature range is the value for optical cable (code) only. The temperature conditions of the connector section is the same as the inverter.

●Outline dimension drawings

<<MR-J3BUS015M>>

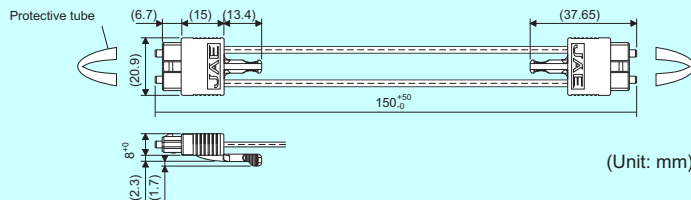

<<MR-J3BUS03M to MR-J3BUS3M>>

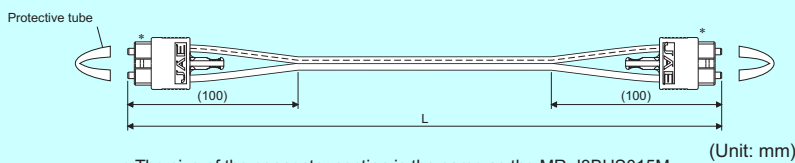

* The size of the connector section is the same as the MR-J3BUS015M.

Cable Model	MR-J3BUS03M	MR-J3BUS05M	MR-J3BUS1M	MR-J3BUS3M
Length L (m)	0.3	0.5	1	3

<<MR-J3BUS5M-A to MR-J3BUS20M-A, MR-J3BUS30M-B to MR-J3BUS50M-B>>

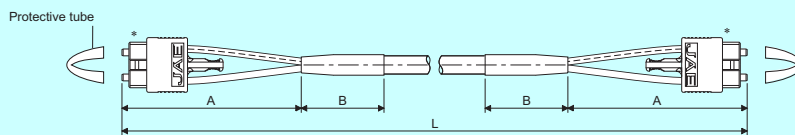

* The size of the connector section is the same as the MR-J3BUS015M.

Cable Model	MR-J3BUS5M-A	MR-J3BUS10M-A	MR-J3BUS20M-A	MR-J3BUS30M-B	MR-J3BUS40M-B	MR-J3BUS50M-B
Length A (mm)	100			150		
Length B (mm)	30			50		
Length L (m)	5	10	20	30	40	50

Operation panel option

LCD operation panel

FR-LU08(-01) A800 A800 Plus F800

The LCD operation panel is capable of displaying text and menus.

●Features

- Replacement with the operation panel (FR-DU08) and installation on the enclosure surface using a connection cable (FR-CB2) are possible. (To connect the FR-LU08, an optional operation panel connection connector (FR-ADP) is required.)
- Parameter settings for up to three inverters can be saved.
- When the FR-LU08 is connected to the inverter, the internal clock of the inverter can be synchronized with the clock of FR-LU08. (Real time clock function)
With a battery (CR1216), the FR-LU08 time count continues even if the main power of the inverter is turned OFF. (The time count of the inverter internal clock does not continue when the inverter power is turned OFF.)
- The FR-LU08-01 meets the IP55 rating (except for the PU connector).



FR-LU08

Parameter unit

FR-PU07 ALL

Interactive parameter unit with LCD display.

●Features

- Remove an operation panel to connect a parameter unit.
- Setting functionality such as direct input method with a numeric keypad, operation status indication, and help function are usable.
- Eight languages can be displayed.
- The FR-PU07 can store parameter settings of up to three inverters.
(In case of the FR-A800, FR-A800 Plus, and FR-F800 series inverters, parameter settings of one inverter can be stored.)



FR-PU07

Parameter unit with battery pack

FR-PU07BB(-L) A800 A800 Plus F800 A701 E700

This parameter unit enables parameter setting without connecting the inverter to power supply. It uses four AA batteries as the power source, but can also be powered with 100VAC.

●Specifications

Item	Description																											
Power supply	• When driven by batteries AA batteries four (nickel hydride(NiMH)/alkali)																											
	• When driven by external power supply (100VAC) AC adaptor *1																											
	• When power is applied to the inverter Power is supplied from the PU connector of the inverter.																											
Battery life *2	<table border="1" style="width: 100%; text-align: center;"> <thead> <tr> <th rowspan="2"></th> <th colspan="3">Alkaline battery</th> <th colspan="3">Nickel metal hydride battery</th> </tr> <tr> <th>A800/ F800</th> <th>A701</th> <th>E700</th> <th>A800/ F800</th> <th>A701</th> <th>E700</th> </tr> </thead> <tbody> <tr> <td>Battery life</td> <td>Approx. 70 min</td> <td>Approx. 90 min</td> <td>Approx. 150 min</td> <td>Approx. 90 min</td> <td>Approx. 120 min</td> <td>Approx. 300 min</td> </tr> <tr> <td>Battery exhaustion warning lamp color changing start time From green to orange (at lowering of battery power)</td> <td colspan="3">Approx. 10 min before</td> <td colspan="3">Approx. 10 min before</td> </tr> </tbody> </table>		Alkaline battery			Nickel metal hydride battery			A800/ F800	A701	E700	A800/ F800	A701	E700	Battery life	Approx. 70 min	Approx. 90 min	Approx. 150 min	Approx. 90 min	Approx. 120 min	Approx. 300 min	Battery exhaustion warning lamp color changing start time From green to orange (at lowering of battery power)	Approx. 10 min before			Approx. 10 min before		
			Alkaline battery			Nickel metal hydride battery																						
		A800/ F800	A701	E700	A800/ F800	A701	E700																					
Battery life	Approx. 70 min	Approx. 90 min	Approx. 150 min	Approx. 90 min	Approx. 120 min	Approx. 300 min																						
Battery exhaustion warning lamp color changing start time From green to orange (at lowering of battery power)	Approx. 10 min before			Approx. 10 min before																								
Switch · connector	Battery ON/OFF switch Modular connector for inverter connection and connector for AC adaptor connection																											
Display functions	Alarm LED for battery exhaustion, Other display is the same as the FR-PU07.																											
Provided appliances	AA alkali battery (for operation check) four *3 Connection cable (FR-CB203) one																											



FR-PU07BB(-L)

*1 Use an AC adaptor with the following specifications.

Output specifications	Rated voltage	5.0VDC±5% or less
	Rated current	2A or more
	Polarity	Plus polarity in the center.
	Plug	JEITA RC-5320A compliant

*2 The battery life is a reference value. It differs depending on the battery and the usage.

*3 Batteries are not included in FR-PU07BB-L.

**Operation panel connection connector
Enclosure surface operation panel**

FR-ADP (A800) (A800 Plus) (F800) (A701)
FR-PA07 (E700) (F700PJ) (D700)

FR-ADP Use this connector to mount an operation panel, which is detached from a 800 series or FR-A701 series inverter, to an enclosure surface.

FR-PA07 This operation panel can be mounted to an enclosure surface to enable inverter operation and monitoring of frequency, etc.

●Appearance diagram

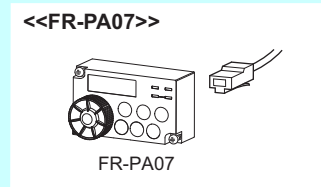
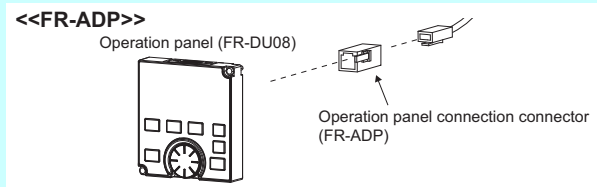

Parameter unit connection cable

FR-CB20[] (ALL)

This cable is for connection of operation panel or parameter unit.

●Specifications

Model	Length
FR-CB201	1m
FR-CB203	3m
FR-CB205	5m

Software

FR Configurator2

SW1DND-FRC2 (A800) (A800 Plus) (F800)

From inverter startup to maintenance, this versatile software allows the user to specify settings easily at the computer. The connection with a personal computer can be easily established with a USB cable. By loading trace data and parameter settings copied to a USB memory device into FR Configurator2, analysis and adjustments can be carried out with ease away from the equipment. Connected inverters are displayed in tree view format. Windows for each function can be accessed by changing the tab for maximum efficiency. The Developer function is used for creating sequence programs and writing them to the inverter to enable the use of the PLC function of the inverter.

●Specifications (compatible operating systems)

Windows® 8.1/Pro/Enterprise (32-bit, 64-bit), Windows® 8, Windows® 7, Windows Vista® (32-bit)

●Function

- System settings (supported by the free trial version)
- Test operation (supported by the free trial version)
- Conversion function (supported by the free trial version)
- Parameter list (supported by the free trial version)
- USB memory parameter copy file edit
- Batch monitor function
- Offline auto tuning
- Diagnosis (faults history) (supported by the free trial version)
- Help (supported by the free trial version)
- Graph function

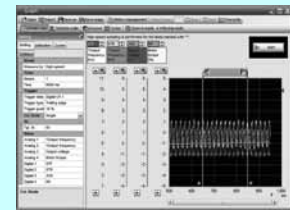
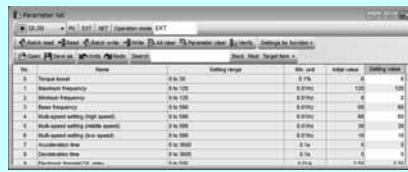
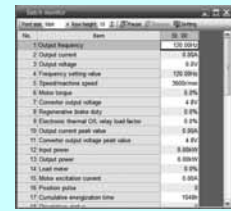
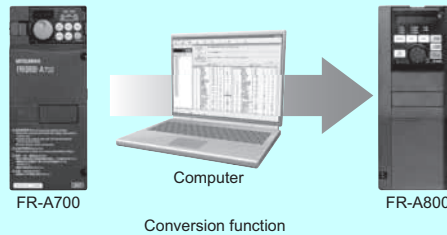

The free trial version with limited functions can be downloaded at Mitsubishi Electric FA Global Website.

Function	Free trial version
Parameter list	○
Diagnosis	○
Graph	×
Batch monitor	×
Test operation	○
Convert	○
Developer	×

Function	Free trial version
USB memory parameter copy file edit	×
Help	○

The try-and-buy version (usable free of charge for a limited period of 20 days with the same functions as the release version) is also offered.

FR Configurator

FR-SW3-SETUP-WE (E700) (F700PJ) (D700) (A701)

The CD-ROM contains the FR-SW1-SETUP-WE software.

FR Configurator software offers an easy and convenient operating platform.

It can be utilized effectively from inverter setting up to maintenance. Parameter setting, monitoring, etc. can be performed on a display of Windows personal computer.

It is connected to the inverter through RS-485 communication. The FR-A701 and E700 series inverters can be easily connected to the personal computer with USB cable.

Use FR-SW3-SETUP-WE (CC-Link seamless) to facilitate setups via CC-Link communication.

●Specifications

Type	FR-SW3-SETUP-WE	FR-SW3-SETUP-WE (CC-Link Seamless)
Supported inverters	FR-A701 FR-E700 *1 FR-F700PJ FR-D700	FR-A701 FR-E700 *1
Supported OS	Windows 7 (32-bit ver.), Vista SP1 or later (32-bit ver.)	

*1 Excluding FR-E700-NF (FL remote communication model).

●Function

- Parameter read, write
- Inverter operating status monitor
- Test operation
- High speed graph function with minimum of 1ms sampling (only in case of USB cable connection *2)
- Easy setup function
- Convert function which automatically converts parameters of the conventional series inverters to the 700 series inverters. *2
- I/O terminal function assignment function *2
- Life check function

*2 Not supported by FR-SW3-SETUP-WE (CC-Link seamless).

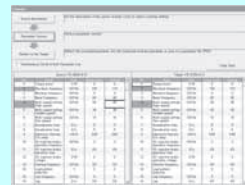

Convert function screen example

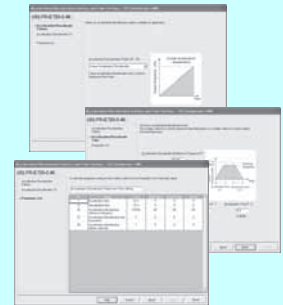

Set wizard function screen example

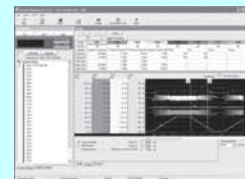

High speed graph function screen example

USB cable

MR-J3USBCBL3M (A800) (F800) (E700)

USB cable for communication with the inverter using the USB port of the PC.

(Since a USB connector for the FR-A701 series inverter is B connector, this cable cannot be used.)

●Appearance diagram

<<MR-J3USBCBL3M>>

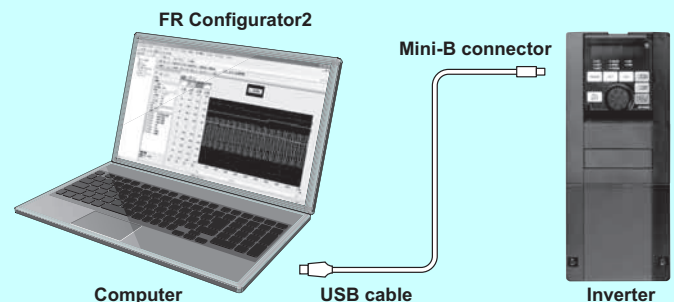
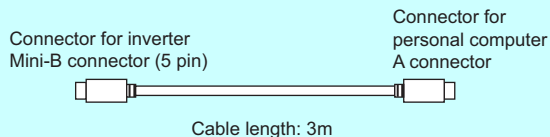

Reactor

AC reactor

FR-HAL (A800) (A800 Plus) (F800) (E700) (F700PJ) (D700)

An AC reactor connected on the input side of the inverter improves power factor and reduces harmonic currents on the input side.

Specifications

Model FR-HAL-□□	200V	400V
	0.4K to 110K*1	H0.4K to H560K*1
Power factor improvement effect*2	Power factor at power supply: About 88% (92.3%*3) with 100% load	
Vibration	5.9m/s ² or less 10 to 55Hz (directions of X, Y, Z axes)	H110K or lower: 5.9m/s ² or less H185K or higher: 2.9m/s ² or less 10 to 55Hz (directions of X, Y, Z axes)
Installation procedure	(H)55K or lower: horizontal plane installation or vertical plane installation (H)75K or higher: horizontal plane installation	

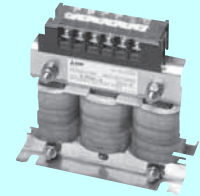

FR-HAL

- *1 Refer to the model in the table of outline dimension drawing for details of capacity.
- *2 Power factor stated above is the value when considering the power supply impedance is 1%. The value changes according to the power supply capacity and power supply impedance.
The load is considered as 100% when the fundamental current value specified in JEM-TR201 is 100%. The power factor improving effect is slightly lower when the motor below 0.4kW is used.
- *3 Improved power factor is about 88%. (It is 92.3% when calculated by applying 1 power factor to the reference waveform according to the Architectural Standard Specifications (Electrical Installation) (2013 revisions) supervised by the Ministry of Land, Infrastructure, Transport and Tourism of Japan.)

Selection

- Make selection according to the applicable motor capacity. (When the inverter capacity is larger than the motor capacity, make selection according to the motor capacity.)
- When the inverter is connected under a large-capacity power transformer (1000kVA or more transformer) or when a power capacitor is to be switched over, an excessive peak current may flow in the power input circuit, damaging the inverter. Be sure to install an AC reactor in such a case.

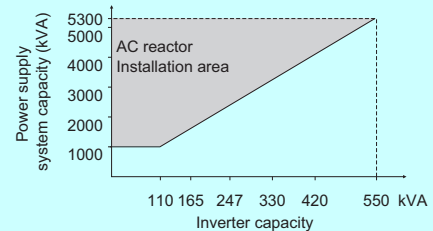

<Selection of reactor when using the large-capacity power transformer>

Connection diagram

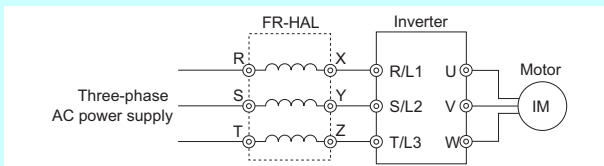

Outline dimension drawings

- The appearance of a typical model. The shape differs according to each model.
- W1 and D1 indicate distances between installation holes. The installation hole size is indicated by d.
- Keep enough clearance around the reactor because it heats up.
(Keep a clearance of minimum 10cm each on top and bottom and minimum 5cm each on right and left regardless of the installation orientation.)

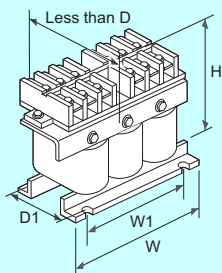

(Unit: mm)

Model	W	W1	H	D	D1	d	Mass (kg)	Model	W	W1	H	D	D1	d	Mass (kg)
0.4K	104	84	99	72	40	M5	0.6	H0.4K	135	120	115	59.6	45	M4	1.5
0.75K	104	84	99	74	44	M5	0.8	H0.75K	135	120	115	59.6	45	M4	1.5
1.5K	104	84	99	77	50	M5	1.1	H1.5K	135	120	115	59.6	45	M4	1.5
2.2K	115	40	115	77	57	M6	1.5	H2.2K	135	120	115	59.6	45	M4	1.5
3.7K	115	40	115	83	67	M6	2.2	H3.7K	135	120	115	70.6	57	M4	2.5
5.5K	115	40	115	83	67	M6	2.3	H5.5K	160	145	142	72	55	M4	3.5
7.5K	130	50	135	100	86	M6	4.2	H7.5K	160	145	142	91	75	M4	5.0
11K	160	75	164	111	92	M6	5.2	H11K	160	145	146	91	75	M4	6.0
15K	160	75	167	126	107	M6	7.0	H15K	220	200	195	105	70	M5	9.0
18.5K	160	75	128	175	107	M6	7.1	H18.5K	220	200	215	170	70	M5	9.0
22K	185	75	150	158	87	M6	9.0	H22K	220	200	215	170	70	M5	9.5
30K	185	75	150	168	87	M6	9.7	H30K	220	200	215	170	75	M5	11
37K	210	75	175	174	82	M6	12.9	H37K	220	200	214	170	100	M5	12.5
45K	210	75	175	191	97	M6	16.4	H45K	280	255	245	165	80	M6	15
55K	210	75	175	201	97	M6	17.4	H55K	280	255	245	170	90	M6	18
75K	240	150	210	213	109	M8	23	H75K	205	75	170	208	105	M6	20
110K	330	170	325	258	127	M10	40	H110K	240	150	225	220	99	M8	28
								H185K	330	170	325	270	142	M10	55
								H280K	330	170	325	320	192	M10	80
								H355K	330	170	325	340	192	M10	80
								H560K	450	300	540	635	345	M12	190

DC reactor

FR-HEL (A800) (A800 Plus) (F800) (E700) (F700PJ) (D700)

A DC reactor connected on the DC side of the inverter improves power factor and reduces harmonic currents on the input side.

● Specifications

Type FR-HEL-□□	200V	400V
	0.4K to 110K*1	H0.4K to H355K*1
Power factor improvement effect*2	Power factor at power supply: About 93% (94.4%*3)	
Vibration	5.9m/s ² or less, 10 to 55Hz (directions of X, Y, Z axes)	
Installation procedure	Horizontal plane installation or vertical plane installation	

*1 Refer to the type in the table of outline dimension drawing for details of capacity.

*2 Power factor stated above is the value when considering the power supply impedance is 1%. The value changes according to the power supply capacity and power supply impedance.

The load is considered as 100% when the fundamental current value specified in JEM-TR201 is 100%. The power factor improving effect is slightly lower when the motor below 0.4kW is used.

*3 Improved power factor is about 93%. (It is 94.4% when calculated by applying 1 power factor to the reference waveform according to the Architectural Standard Specifications (Electrical Installation) (2013 revisions) supervised by the Ministry of Land, Infrastructure, Transport and Tourism of Japan.)

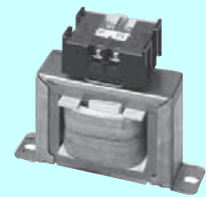

FR-HEL

● Selection

- Make selection according to the applicable motor capacity. (When the inverter capacity is larger than the motor capacity, make selection according to the motor capacity.)
- For the 75K or higher inverters, or whenever a 75kW or higher motor is used, always connect a DC reactor (not enclosed with the 800 series inverters).

● Connection diagram

- Connect the reactor to terminal P1 and P of the inverter. Make sure to remove a jumper across terminal P1-P before connecting. (A failure to do so will produce no power factor improving effect.)
- The wiring length between the reactor and inverter should be 5m maximum and minimized.

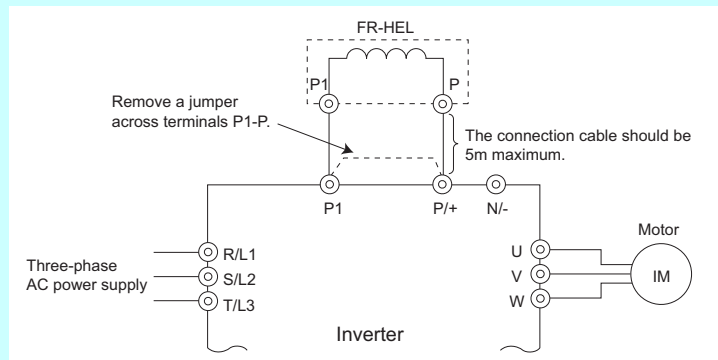

● Outline dimension drawings

- The appearance of a typical model. The shape differs according to each model.
- W1 and D1 indicate distances between installation holes. The installation hole size is indicated by d.
- Keep enough clearance around the reactor because it heats up. (Keep a clearance of minimum 10cm each on top and bottom and minimum 5cm each on right and left regardless of the installation orientation.)

(Unit: mm)

Model	W	W1	H	D	D1	d	Mass (kg)	Model	W	W1	H	D	D1	d	Mass (kg)
0.4K	70	60	71	61	—	M4	0.4	H0.4K	90	75	78	60	—	M5	0.6
0.75K	85	74	81	61	—	M4	0.5	H0.75K	66	50	100	70	48	M4	0.8
1.5K	85	74	81	70	—	M4	0.8	H1.5K	66	50	100	80	54	M4	1
2.2K	85	74	81	70	—	M4	0.9	H2.2K	76	50	110	80	54	M4	1.3
3.7K	77	55	92	82	57	M4	1.5	H3.7K	86	55	120	95	69	M4	2.3
5.5K	77	55	92	92	67	M4	1.9	H5.5K	96	60	128	100	75	M5	3
7.5K	86	60	113	98	72	M4	2.5	H7.5K	96	60	128	105	80	M5	3.5
11K	105	64	133	112	79	M6	3.3	H11K	105	75	137	110	85	M5	4.5
15K	105	64	133	115	84	M6	4.1	H15K	105	75	152	125	95	M5	5
18.5K	105	64	93	165	94	M6	4.7	H18.5K	114	75	162	120	80	M5	5
22K	105	64	93	175	104	M6	5.6	H22K	133	90	178	120	75	M5	6
30K	114	72	100	200	101	M6	7.8	H30K	133	90	178	120	80	M5	6.5
37K	133	86	117	195	98	M6	10	H37K	133	90	187	155	100	M5	8.5
45K	133	86	117	205	108	M6	11	H45K	133	90	187	170	110	M5	10
55K	153	126	132	209	122	M6	12.6	H55K	152	105	206	170	106	M6	11.5
75K	150	130	190	340	310	M6	17	H75K	140	120	185	320	295	M6	16
90K	150	130	200	340	310	M6	19	H90K	150	130	190	340	310	M6	20
110K	175	150	200	400	365	M8	20	H110K	150	130	195	340	310	M6	22
								H132K	175	150	200	405	370	M8	26
								H160K	175	150	205	405	370	M8	28
								H185K	175	150	240	405	370	M8	29
								H220K	175	150	240	405	370	M8	30
								H250K	190	165	250	440	400	M8	35
								H280K	190	165	255	440	400	M8	38
								H315K	210	185	250	495	450	M10	42
								H355K	210	185	250	495	450	M10	46

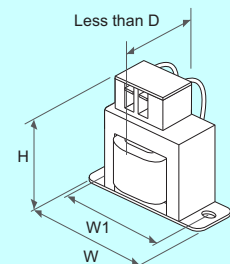

FR-HEL-0.4K to 2.2K
FR-HEL-H0.4K

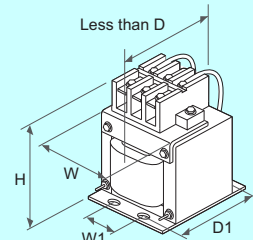

FR-HEL-3.7K to 55K
FR-HEL-H0.75K to H55K

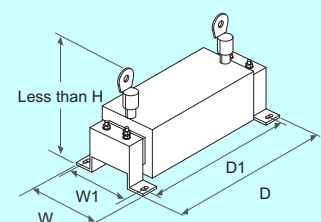

FR-HEL-75K to 110K
FR-HEL-H75K to H355K

Braking option

Brake resistor High-duty brake resistor

MRS, MYS (E700) (F700PJ) (D700)

FR-ABR (A800) (A800 Plus) (E700) (F700PJ) (D700)

Only models with a built-in brake transistor can be used.

Larger value of the regenerative brake duty can be set by connecting this high-duty brake resistor to the inverter.

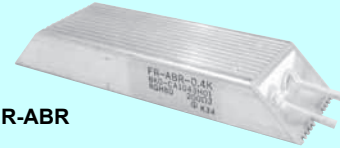

FR-ABR

● Specifications

Model MRS Type, MYS Type	200V				
	MRS120W200	MRS120W100	MRS120W60	MRS120W40	MYS220W50 *2
Applicable inverter capacity (kW)	0.4	0.75	1.5, 2.2	2.2, 3.7	3.7
Permissible duty *1	3%ED				6%ED
Resistance value (Ω)	200	100	60	40	50 (×1/2)

Model FR-ABR-□□	200V								
	0.4K	0.75K	2.2K	3.7K	5.5K	7.5K	11K	15K *2	22K *2
Applicable inverter capacity (kW)	0.4	0.75	1.5, 2.2	3.7	5.5	7.5	11	15	18.5, 22
Braking torque	150% 5s			100% 5s					
Permissible duty *1	10%ED						6%ED		
Resistance value (Ω)	200	100	60	40	25	20	13	18 (×1/2)	13 (×1/2)
Approximate mass (kg)	0.2	0.4	0.5	0.8	1.3	2.2	3.5	2.4 (×2)	3.3 (×2)

Model FR-ABR-□□	400V									
	H0.4K	H0.75K	H1.5K	H2.2K	H3.7K	H5.5K	H7.5K	H11K	H15K *3	H22K *2
Applicable inverter capacity (kW)	0.4	0.75	1.5	2.2	3.7	5.5	7.5	11	15	18.5, 22
Braking torque	100% 5s									
Permissible duty *1	10%ED							6%ED		
Resistance value (Ω)	1200	700	350	250	150	110	75	52	18 (×1/2)	52 (×1/2)
Approximate mass (kg)	0.2	0.2	0.4	0.5	0.8	1.3	2.2	3.2	2.4 (×2)	3.3 (×2)

*1 The permissible duty indicates braking capability including the motor loss, and thereby the actual duty of the resistor is slightly smaller.

*2 Use two units in parallel.

*3 Use two units in series. FR-ABR-15K is indicated on the resistor (same resistor as the 200V class 15K).

● Selection

- Make selection according to the applicable motor capacity of the above specifications.
- The model with built-in brake resistor and external brake resistor.

Inverter		Built-in Brake Resistor	External Brake Resistor (built-in brake transistor)
FR-A800, FR-A800 Plus	0.4K to 7.5K	○	○
	11K to 22K	×	○
	30K or higher	×	×
FR-F800	All capacities	×	×
FR-E700	0.1K, 0.2K	×	×
	0.4K or higher	×	○
FR-F700PJ	All capacities	×	○
FR-D700	0.1K, 0.2K	×	×
	0.4K or higher	×	○

○: Available ×: Not available

● Connection diagram

- Connect across terminals P and PR of the inverter.
- When using the model with a brake resistor inside, be sure to remove a jumper across terminals PX and PR. (Note that a jumper across terminals P1 and P should not be removed by mistake.)
- The temperature of the MRS type and MYS type brake resistor becomes 200°C or more and the FR-ABR becomes 300°C or more, care must be taken for installation and heat dissipation.
- The following sequence is recommended to prevent overheat and burnout of the brake resistor in case the brake transistor is damaged.

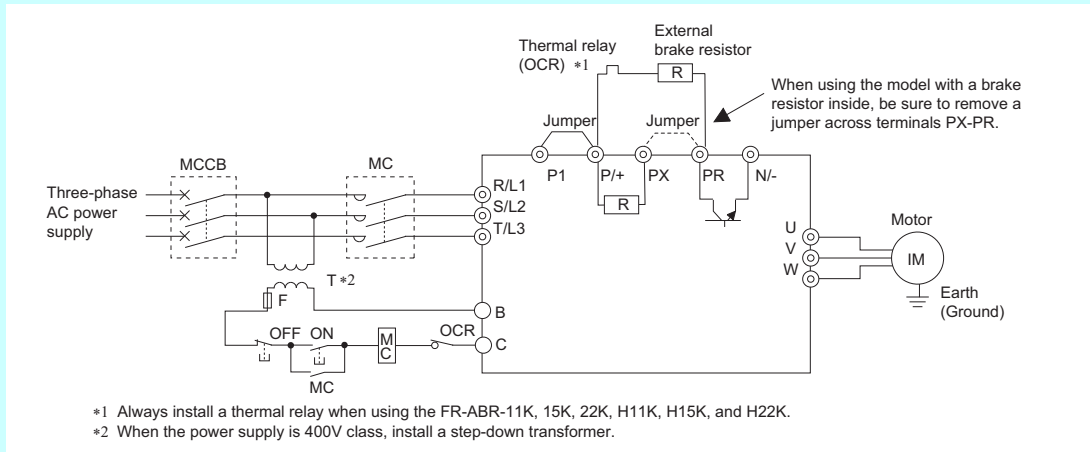

● Outline dimension drawings

<<MRS type>>

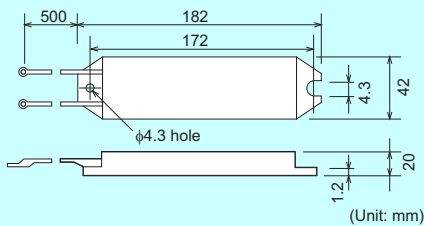

<<MYS type>> *

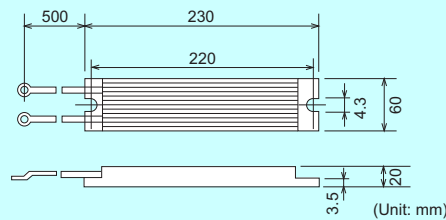

* Outline dimension drawing of one resistor.

<<FR-ABR>>

FR-ABR-0.4K to 7.5K, H0.4K to H7.5K

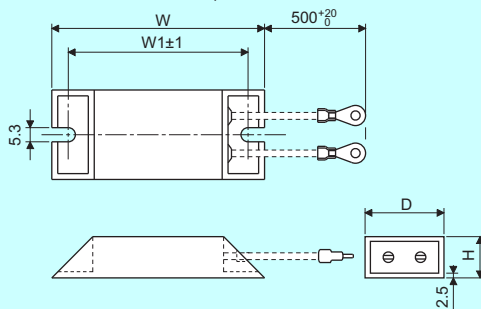

FR-ABR-11K to 22K, H11K to H22K

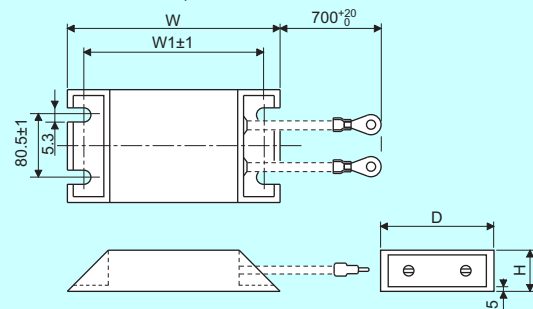

Voltage	Brake Resistor Model	Outline Dimension				Brake Resistor Model	Outline Dimension				
		W	W1	H	D		W	W1	H	D	
200V	FR-ABR-0.4K	140	125	21	40	400V	FR-ABR-H0.4K	115	100	21	40
	FR-ABR-0.75K	215	200	21	40		FR-ABR-H0.75K	140	125	21	40
	FR-ABR-2.2K	240	225	26	50		FR-ABR-H1.5K	215	200	21	40
	FR-ABR-3.7K	215	200	33	61		FR-ABR-H2.2K	240	225	26	50
	FR-ABR-5.5K	335	320	33	61		FR-ABR-H3.7K	215	200	33	61
	FR-ABR-7.5K	400	385	40	80		FR-ABR-H5.5K	335	320	33	61
	FR-ABR-11K	400	385	50	100		FR-ABR-H7.5K	400	385	40	80
	FR-ABR-15K*	300	285	50	100		FR-ABR-H11K	400	385	50	100
FR-ABR-22K*	400	385	50	100	FR-ABR-H15K*	300	285	50	100		
					FR-ABR-H22K*	450	435	50	100		

* Outline dimension drawing of one resistor.

Braking option

Brake unit Discharging resistor or resistor unit

FR-BU2 (A800) (A800 Plus) (F800) (E700) (F700PJ) (D700)
 GRZG (A800) (A800 Plus) (F800) (E700) (F700PJ) (D700)
 FR-BR (A800) (A800 Plus) (F800) (E700) (F700PJ) (D700)
 MT-BR5 (A800) (A800 Plus) (F800)

Braking options have larger braking capability than the external brake resistor. These options can be connected to the inverter with or without a built-in brake transistor. Select from three discharging resistors according to the required braking torque.

● Specifications

<<Brake unit>>

Model FR-BU2-[]	200V						400V						
	1.5K	3.7K	7.5K	15K	30K	55K	H7.5K	H15K	H30K	H55K	H75K	H220K	H280K
Applicable motor capacity	Capacity of the motor to be used with differs according to the braking torque and duty (%ED)												
Connected brake resistor	GRZG type, FR-BR, MT-BR5 (Refer to the table below for combination.)											MT-BR5 *1	
Multiple (parallel) operation	Up to 10 units (Note that torque generated is not more than the tolerable overcurrent amount of connected inverter.)												
Approximate mass (kg)	0.9	0.9	0.9	0.9	1.4	2.0	0.9	0.9	1.4	2.0	2.0	13	13



FR-BU2

*1 Please contact your sales representative to use a brake resistor other than MT-BR5.

<<Discharging Resistor>>

Model GRZG type *2	200V				400V		
	GZG300W-50Ω (1 unit)	GRZG200-10Ω (3 units)	GRZG300-5Ω (4 units)	GRZG400-2Ω (6 units)	GRZG200-10Ω (3 units)	GRZG300-5Ω (4 units)	GRZG400-2Ω (6 units)
Number of resistors	1	3 in series (1 set)	4 in series (1 set)	6 in series (1 set)	6 in series (2 sets)	8 in series (2 sets)	12 in series (2 sets)
Resistance value (Ω)	50	30	20	12	60	40	24
Continuous permissible power (W)	100	300	600	1200	600	1200	2400

*2 The 1 set contains the number of units in the parentheses. For the 400V class, 2 sets are required.

<<Resistor unit>>

Model FR-BR-[]	200V			400V			Model MT-BR5-[]	200V	400V
	15K	30K	55K	H15K	H30K	H55K		55K	H75K
Resistance value (Ω)	8	4	2	32	16	8	Resistance value (Ω)	2	6.5
Continuous permissible power (W)	990	1990	3910	990	1990	3910	Continuous permissible power (W)	5500	7500
Approximate mass (kg)	15	30	70	15	30	70	Approximate mass (kg)	70	65

● Table of combination of the brake unit and resistor unit

Brake Unit Model		Discharging Resistor or Resistor Unit Model				
		GRZG type		FR-BR	MT-BR5	
		Model *1	Number of connectable units			
200V class	FR-BU2-1.5K	GZG 300W-50Ω (1 unit)	1 unit	—	—	
	FR-BU2-3.7K	GRZG 200-10Ω (3 units)	3 in series (1 set)	—	—	
	FR-BU2-7.5K	GRZG 300-5Ω (4 units)	4 in series (1 set)	—	—	
	FR-BU2-15K	GRZG 400-2Ω (6 units)	6 in series (1 set)	FR-BR-15K	—	
	FR-BU2-30K	—	—	FR-BR-30K	—	
400V class	FR-BU2-55K	—	—	FR-BR-55K	MT-BR5-55K	
	FR-BU2-H7.5K	GRZG 200-10Ω (3 units)	6 in series (2 sets)	—	—	
	FR-BU2-H15K	GRZG 300-5Ω (4 units)	8 in series (2 sets)	FR-BR-H15K	—	
	FR-BU2-H30K	GRZG 400-2Ω (6 units)	12 in series (2 sets)	FR-BR-H30K	—	
	FR-BU2-H55K	—	—	FR-BR-H55K	—	
	FR-BU2-H75K	—	—	—	MT-BR5-H75K	
	FR-BU2-H220K	—	—	—	3×MT-BR5-H75K *2	
FR-BU2-H280K	—	—	—	4×MT-BR5-H75K *2		

*1 The 1 set contains the number of units in the parentheses. For the 400V class, 2 sets are required.

*2 The number before the model name explains the number of connectable units in parallel.

● Selection

<<When GRZG type is connected>>

Power Supply Voltage	Motor(kW)	Braking Torque														
		0.4	0.75	1.5	2.2	3.7	5.5	7.5	11	15	18.5	22	30	37	45	55
200V class	50% 30s	FR-BU2-1.5K		FR-BU2-3.7K	FR-BU2-7.5K	FR-BU2-15K	2×FR-BU2-15K *1		3×FR-BU2-15K *1		4×FR-BU2-15K *1		4×FR-BU2-15K *1			
	100% 30s	FR-BU2-1.5K	FR-BU2-3.7K	FR-BU2-7.5K	FR-BU2-15K	2×FR-BU2-15K *1		3×FR-BU2-15K *1	4×FR-BU2-15K *1	5×FR-BU2-15K *1	6×FR-BU2-15K *1	7×FR-BU2-15K *1				
400V class	50% 30s	— *2		FR-BU2-H7.5K			FR-BU2-H15K	FR-BU2-H30K		2×FR-BU2-H30K *1						
	100% 30s	— *2		FR-BU2-H7.5K	FR-BU2-H15K	FR-BU2-H30K	2×FR-BU2-H30K *1		3×FR-BU2-H30K *1		4×FR-BU2-H30K *1					

*1 The number before the model name explains the number of connectable units in parallel.

*2 The inverter of 1.5K or lower in the 400V class cannot be used in combination with a brake unit. To use in combination with a brake unit, use the inverter of 2.2K or higher.

<<When the FR-BR is connected>>

%ED at short-time rating when braking torque is 100%

Motor Capacity		5.5kW	7.5kW	11kW	15kW	18.5kW	22kW	30kW	37kW	45kW	55kW
200V	FR-BU2-15K	80	40	15	30	—	—	—	—	—	—
	FR-BU2-30K	—	—	65	30	25	15	10	—	—	—
	FR-BU2-55K	—	—	—	—	90	60	30	20	15	10
400V	FR-BU2-H15K	80	40	15	10	—	—	—	—	—	—
	FR-BU2-H30K	—	—	65	30	25	15	10	—	—	—
	FR-BU2-H55K	—	—	—	—	90	60	30	20	15	10

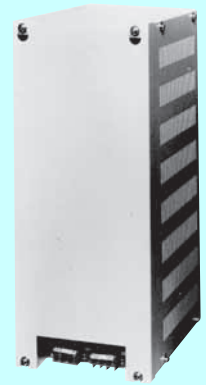

FR-BR

Braking torque (%) at 10%ED in 15s

Motor Capacity		5.5kW	7.5kW	11kW	15kW	18.5kW	22kW	30kW	37kW	45kW	55kW
200V	FR-BU2-15K	280	200	120	100	80	70	—	—	—	—
	FR-BU2-30K	—	—	260	180	160	130	100	80	70	—
	FR-BU2-55K	—	—	—	—	300	250	180	150	120	100
400V	FR-BU2-H15K	280	200	120	100	80	70	—	—	—	—
	FR-BU2-H30K	—	—	260	180	160	130	100	80	70	—
	FR-BU2-H55K	—	—	—	—	300	250	180	150	120	100

$$\text{Regeneration load time factor (operating duty) \%ED} = \frac{t_b}{t_c} \times 100 \quad t_b < 15\text{s (continuous operating time)}$$

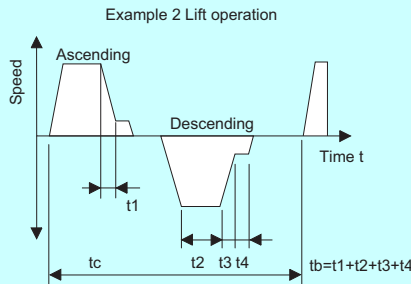
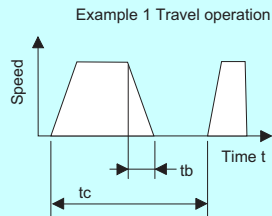

<<When the MT-BR5 is connected>>

%ED at short-time rating when braking torque is 100%

Motor Capacity		75kW	90kW	110kW	132kW	160kW	185kW	220kW	250kW	280kW	315kW	355kW	375kW	400kW	450kW	500kW	560kW
200V class FR-BU2-55K	1	5	—	—	—	—	—	—	—	—	—	—	—	—	—	—	—
	2	20	15	10	—	—	—	—	—	—	—	—	—	—	—	—	—
400V class FR-BU2-H75K	1	10	5	—	—	—	—	—	—	—	—	—	—	—	—	—	—
	2	40	25	20	10	5	5	—	—	—	—	—	—	—	—	—	—
400V class FR-BU2-H220K	1	80	60	40	25	15	10	10	5	—	—	—	—	—	—	—	—
	2	—	—	—	—	—	—	20	20	15	15	15	10	10	10	5	—
400V class FR-BU2-H280K	1	—	80	65	40	30	20	15	10	10	5	—	—	—	—	—	—
	2	—	—	—	—	—	—	—	—	—	20	20	15	15	15	10	10

Braking torque (%) at short-time rating in 15s

Motor Capacity		75kW	90kW	110kW	132kW	160kW	185kW	220kW	250kW	280kW	315kW	355kW	375kW	400kW	450kW	500kW	560kW
200V class FR-BU2-55K	1	70	60	50	—	—	—	—	—	—	—	—	—	—	—	—	—
	2	150	120	100	—	—	—	—	—	—	—	—	—	—	—	—	—
400V class FR-BU2-H75K	1	100	80	70	55	45	40	35	—	25	—	—	20	—	—	—	—
	2	150	150	135	110	90	80	70	60	50	45	40	40	—	—	—	—
400V class FR-BU2-H220K	1	—	—	150	150	135	115	100	80	55	—	—	—	—	—	—	—
	2	—	—	—	—	—	—	—	—	150	150	140	120	110	100	90	80
400V class FR-BU2-H280K	1	—	—	—	—	150	150	150	125	100	70	—	—	—	—	—	—
	2	—	—	—	—	—	—	—	—	—	—	—	150	150	130	115	100

*1 The number explains the number of connectable units in parallel.

*2 To obtain a large braking torque, the motor has to have a torque characteristic that meets the braking torque. Check the torque characteristic of the motor.

Braking option

● Connection diagram (Sink logic)

<<When the FR-BU2 and FR-BR are connected>>

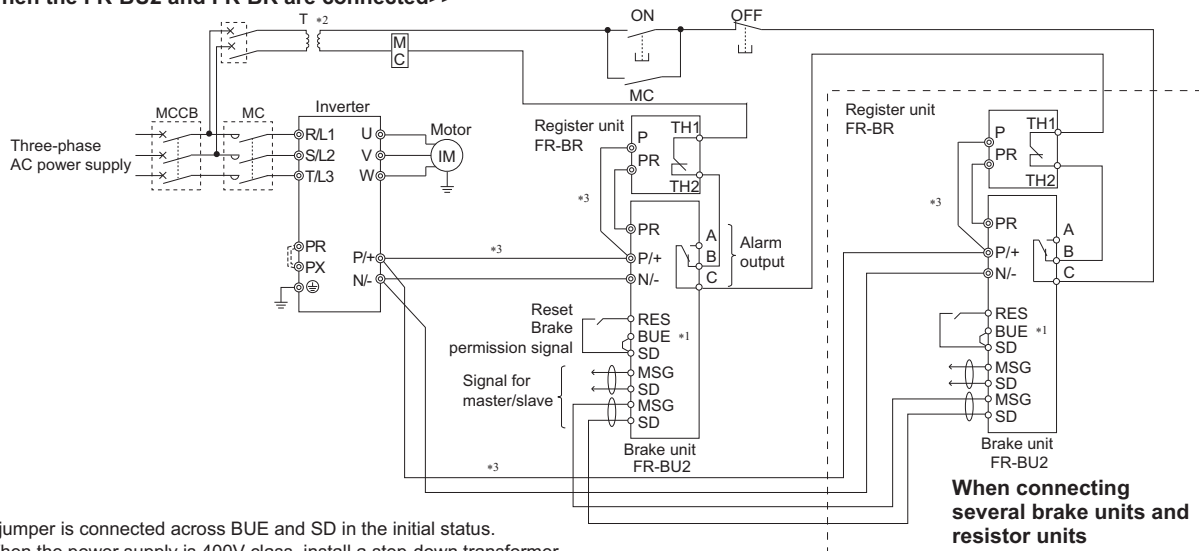

- *1 A jumper is connected across BUE and SD in the initial status.
 - *2 When the power supply is 400V class, install a step-down transformer.
 - *3 The wiring distance between the inverter, brake unit (FR-BU2) and resistor unit (FR-BR) should be within 5m. If twisted wires are used, the distance should be within 10m.
- When connecting several FR-BU2 to one inverter, connect P/+ of each FR-BU2 and of the inverter and N/- respectively. Do not pass wires from terminal P/+ and N/- of the FR-BU2 to terminals of other FR-BU2.

When connecting several brake units and resistor units

● Outline dimension drawings

<<FR-BU2>>

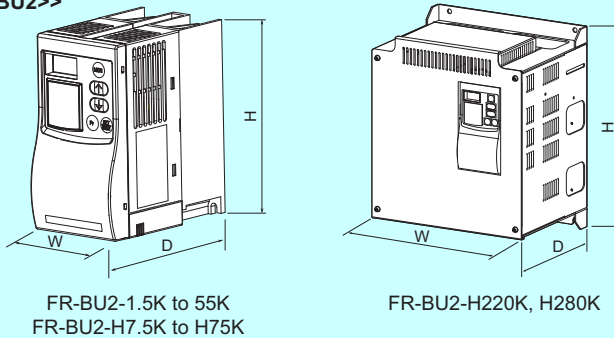

FR-BU2-1.5K to 55K
FR-BU2-H7.5K to H75K

FR-BU2-H220K, H280K

(Unit: mm)

Model	W	H	D
FR-BU2-1.5K to 15K	68	128	132.5
FR-BU2-30K	108	128	129.5
FR-BU2-55K	170	128	142.5
FR-BU2-H7.5K, H15K	68	128	132.5
FR-BU2-H30K	108	128	129.5
FR-BU2-H55K, H75K	170	128	142.5
FR-BU2-H220K, H280K	250	300	200

<<GRZG type>>

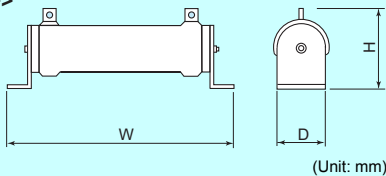

(Unit: mm)

Model	W	H	D
GZG300W	335	78	40
GRZG200	306	55	26
GRZG300	334	79	40
GRZG400	411	79	40

- The maximum temperature rise of the discharging resistors is approximately 100°C. Use heat-resistant wires to perform wiring and make sure that they will not make contact with resistors.
- Do not touch the discharging resistor while the power is ON or for about 10 minutes after the power supply turns OFF. Otherwise, electric shock may result.

<<FR-BR>>

(Unit: mm)

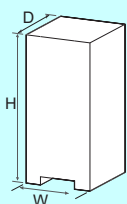

Resistor Unit			
Model	W	H	D
FR-BR-15K	170	450	220
FR-BR-30K	340	600	220
FR-BR-55K	480	700	450
FR-BR-H15K	170	450	220
FR-BR-H30K	340	600	220
FR-BR-H55K	480	700	450

- The temperature rise of the resistor unit is about a maximum of 100°C. Therefore, use heat-resistant wires (such as glass wires).

<<MT-BR5>>

(Unit: mm)

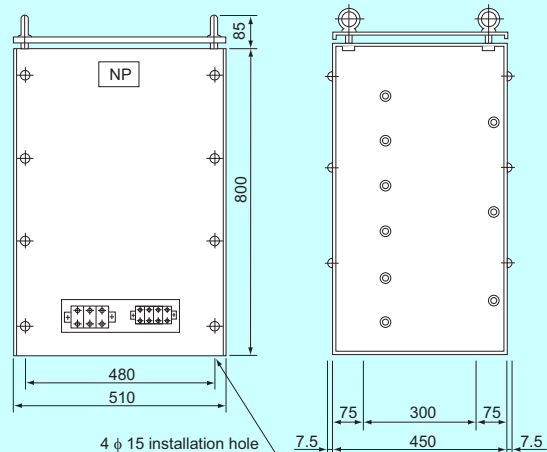

- Be sure to select the well-ventilated place for installation of the resistor unit. Ventilation is necessary when installing the resistor in a place, e.g. enclosure, where heat is not well diffused.
- The temperature rise of the resistor unit is about a maximum of 150°C. Therefore, wire the cable so as not to touch the resistor. Also, separate a component, which is low in heat-resistant property, at least 40 to 50cm from the resistors.
- The temperature of the resistor unit abnormally increases if the brake unit is operated exceeding the specified duty. Since the resistor unit may result in overheat if the temperature of the brake unit is left unchanged, switch off the inverter.

Power regeneration converter

MT-RC (A800) (A800 Plus) (F800)

A power regeneration converter allows energy generated at braking operation of the inverter to be regenerated to the power supply. Since a converter does not require a discharging resistor necessary like a brake unit, it is effective in space and energy saving and it provides a large peak braking torque.

●Specifications

Model MT-RC-[]	400V			
	H75K	H160K	H220K	H280K
Rated current (A) *1	102	218	300	382
Rated input AC power supply	Three-phase 380 to 460V 50/60Hz			
Permissible AC voltage fluctuation	Three-phase 323 to 506V 50/60Hz			
Approximate mass (kg)	65	115	155	235
AC reactor type MT-RCL-[] (standard accessory)	H75K	H160K	H220K	H280K
Approximate mass (kg)	130	240	410	580

*1 The rated current indicates the current flow in the main circuit DC bus (terminal P/+, N/-).

●Selection

- 1) Select the unit according to the motor capacity and magnitude of the braking torque referring to the table below.
- 2) Do not use the MT-RC whose capacity is larger than the stated combination in the table below.
(Even if the MT-RC larger in capacity is selected, continuous braking torque will not exceed 100% of the rated motor.)

Braking torque (%) at continuous rating (% value on the assumption that the rated motor torque is 100%.)

Motor Capacity (kW)	75	90	110	132	150	160	185	200	220	250	280
Inverter model	75K	110K	110K	160K	160K	160K	220K	220K	220K	280K	280K
MT-RC-H75K	100	80	65	55	50	45	40	35	30	30	25
MT-RC-H160K	—	100	100	100	100	100	85	80	70	60	55
MT-RC-H220K	—	—	—	—	—	—	100	100	100	85	75
MT-RC-H280K	—	—	—	—	—	—	—	—	—	100	100

●Connection diagram

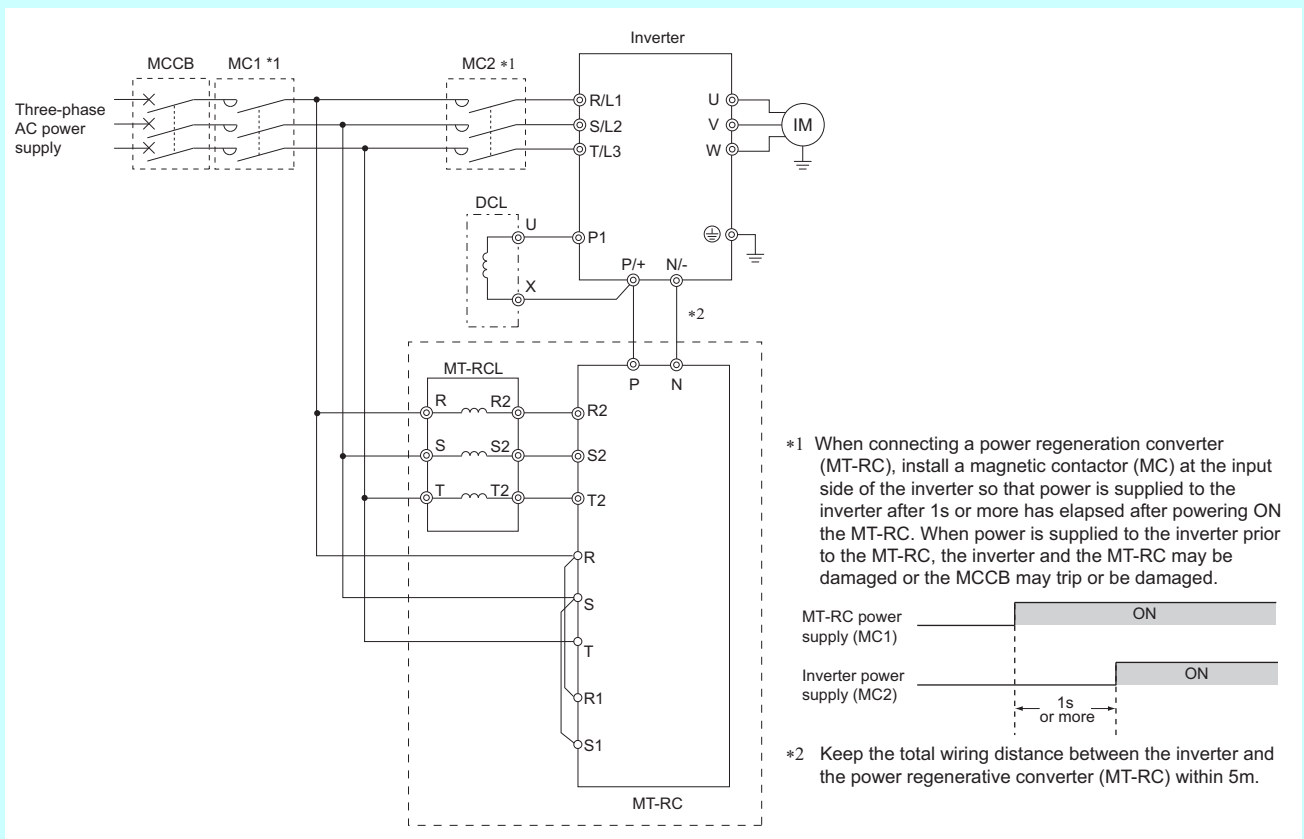

Braking option

●Outline dimension drawings

<<MT-RC>>

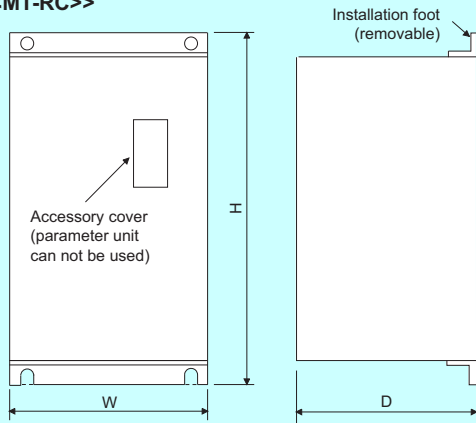

(Unit: mm)

Model	W	H	D
400V MT-RC-H75K	480	740	360
MT-RC-H160K	498	1010	380
MT-RC-H220K	680	1010	380
MT-RC-H280K	790	1330	440

<<MT-RCL>>

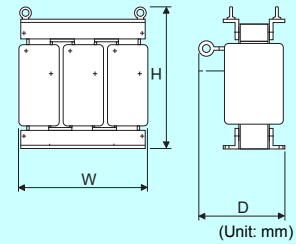

(Unit: mm)

Model	W	H	D
400V MT-RCL-H75K	390	385	358
MT-RCL-H160K	515	465	380
MT-RCL-H220K	630	655	565
MT-RCL-H280K	690	690	620

Power regeneration common converter Dedicated standalone reactor

FR-CV (A800, A800 Plus, F800, E700, F700PJ, D700)
FR-CVL (A800, A800 Plus, F800, E700, F700PJ, D700)

A power regeneration common converter and dedicated standalone reactor enable 100%-torque continuous regeneration to support continuous regenerative operation for line control, etc. These options save energy since regeneration energy is used for the other inverters and excess energy is returned to the power supply.

●Specifications

200V class type	Heatsink protrusion attachment structure FR-CV-[]	7.5K	11K	15K	22K	30K	37K	55K
	Enclosure mounting structure FR-CV-[]-AT	7.5K	11K	15K	22K	30K	— *1	— *1
Applicable inverter capacity (kW) *2	7.5, 11, 15, 22, 30, 37, 55							
Applicable current (A) *2	33, 46, 61, 90, 115, 145, 215							
Regenerative braking torque	Short-time rating 150% torque 60s Continuous rating 100% torque							
Rated input AC power supply	Three-phase 200 to 220V 50Hz/three phase 200 to 230V 60Hz							
Permissible AC voltage fluctuation	Three-phase 170 to 242V 50Hz/three phase 170 to 253V 60Hz							
Approximate mass (kg)	Heatsink protrusion attachment structure	5.0	5.0	6.0	9.5	10.5	34	38
	Enclosure mounting structure	6.5	6.5	7.5	12.5	13.5		
AC reactor type FR-CVL-[] (separately available)		7.5K	11K	15K	22K	30K	37K	55K
	Approximate mass (kg)	4.5	4.0	5.5	6.5	11.0	16.0	20.0



400V class type	Heatsink protrusion attachment structure FR-CV-[]	H7.5K	H11K	H15K	H22K	H30K	H37K	H55K
	Enclosure mounting structure FR-CV-[]-AT	H7.5K	H11K	H15K	H22K	H30K	— *1	— *1
Applicable inverter capacity (kW) *2	7.5, 11, 15, 22, 30, 37, 55							
Applicable current (A) *2	17, 23, 31, 43, 57, 71, 110							
Regenerative braking torque	Short-time rating 150% torque 60s Continuous rating 100% torque							
Rated input AC power supply	Three-phase 380 to 480V 50Hz/60Hz							
Permissible AC voltage fluctuation	Three-phase 323 to 528V 50Hz/60Hz							
Approximate mass (kg)	Heatsink protrusion attachment structure	6.0	6.0	6.0	10.0	10.0	32.5	32.5
	Enclosure mounting structure	7.5	7.5	7.5	13.0	13.0		
AC reactor type FR-CVL-[] (separately available)		H7.5K	H11K	H15K	H22K	H30K	H37K	H55K
	Approximate mass (kg)	7.0	7.5	8.0	10.5	12.0	16.0	22.5

- *1 Changing the position of installation foot allows either heatsink protrusion type or enclosure-mounting type to be installed. The position of installation foot is fixed for heatsink protrusion structure when shipped from the factory.
- *2 The applicable inverter capacity is the total capacity (6 units maximum) of the inverters. Select the converter so that the total rated currents of the motors will not exceed the applicable current.

● Connection diagram (Sink logic)

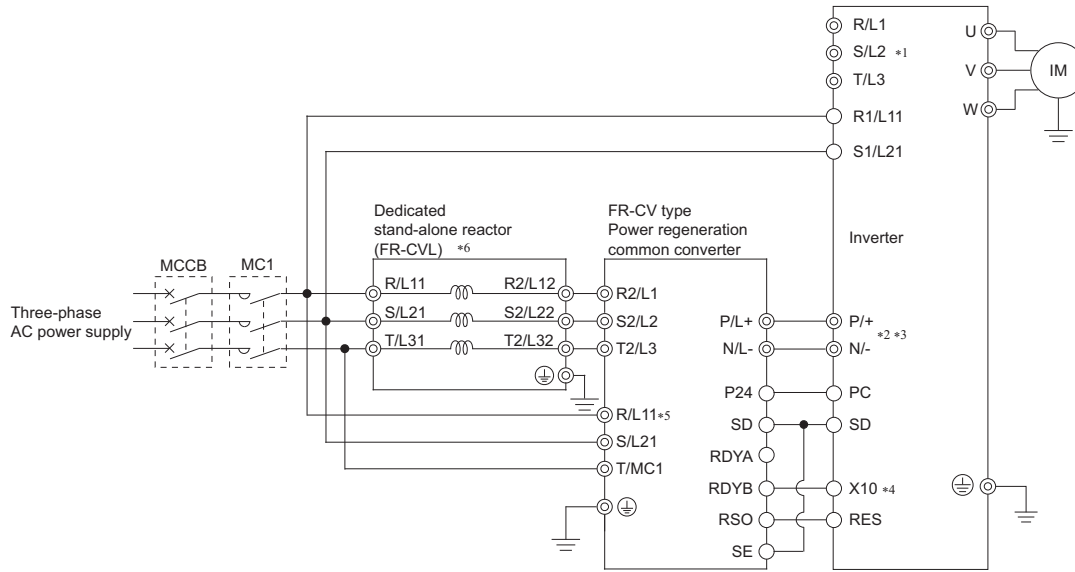

- *1 Remove the jumpers across the inverter terminals R/L1-R1/L11, S/L2-S1/L21, and connect the control circuit power supply to the R1/L11 and S1/L21 terminals. Always keep the power input terminals R/L1, S/L2, T/L3 open. Incorrect connection will damage the inverter. Opposite polarity of terminals N/-, P/+ will damage the inverter.
- *2 Do not insert an MCCB between terminals P/+-N/- (between P/L+-P/+, between N/L--N/-).
- *3 Keep the total wiring distance between the inverter and the power regeneration common converter (FR-CV) within 5m.
- *4 Assign the terminal for X10 signal using input terminal function selection.
- *5 Always connect the power supply and terminals R/L11, S/L21, T/MC1. If the inverter is operated without connection, the power regeneration common converter will be damaged.
- *6 Install the dedicated stand-alone reactor (FR-CVL) on horizontal plane.
- *7 The use of a power factor AC reactor (FR-HAL) may reduce the effect of the power regeneration function. Do not use it.
- *8 Do not use a power factor improvement DC reactor (FR-HEL).

● Outline dimension drawings

<<FR-CV(H)>>

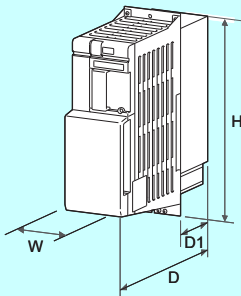

FR-CV(H) (Unit: mm)

Voltage/Capacity	W	H	D	D1	
200V	7.5K/11K	90	300	303	103
	15K	120	300	305	105
	22K/30K	150	380	322	122
	37K/55K	400	620	250	135
400V	7.5K/11K/15K	120	300	305	105
	22K/30K	150	380	305	105
	37K/55K	400	620	250	135

<<FR-CV(H)-AT>>

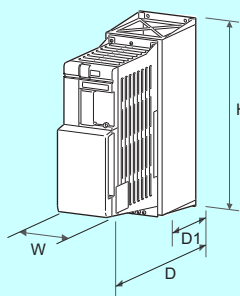

FR-CV(H)-AT (Unit: mm)

Voltage/Capacity	W	H	D	D1	
200V	7.5K/11K	110	330	315	115
	15K	130	330	320	120
	22K/30K	160	410	350	150
400V	7.5K/11K/15K	130	330	320	120
	22K/30K	160	410	350	150

<<FR-CVL>>

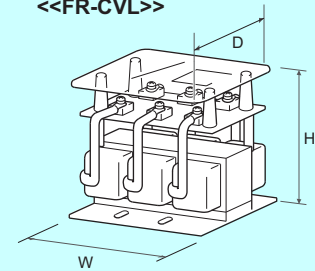

FR-CVL (Unit: mm)

Voltage/Capacity	W	H	D	
200V	7.5K/11K/15K	165	155	130
	22K	165	155	140
	30K	215	175	160
	37K	220	200	320
	55K	250	225	335
400V	7.5K/11K	220	200	135
	15K	220	205	135
	22K	220	215	150
	30K	245	220	185
	37K	245	265	230
	55K	290	280	230

* Indicates maximum outside dimensions.

<<FR-HC2-H280K>>

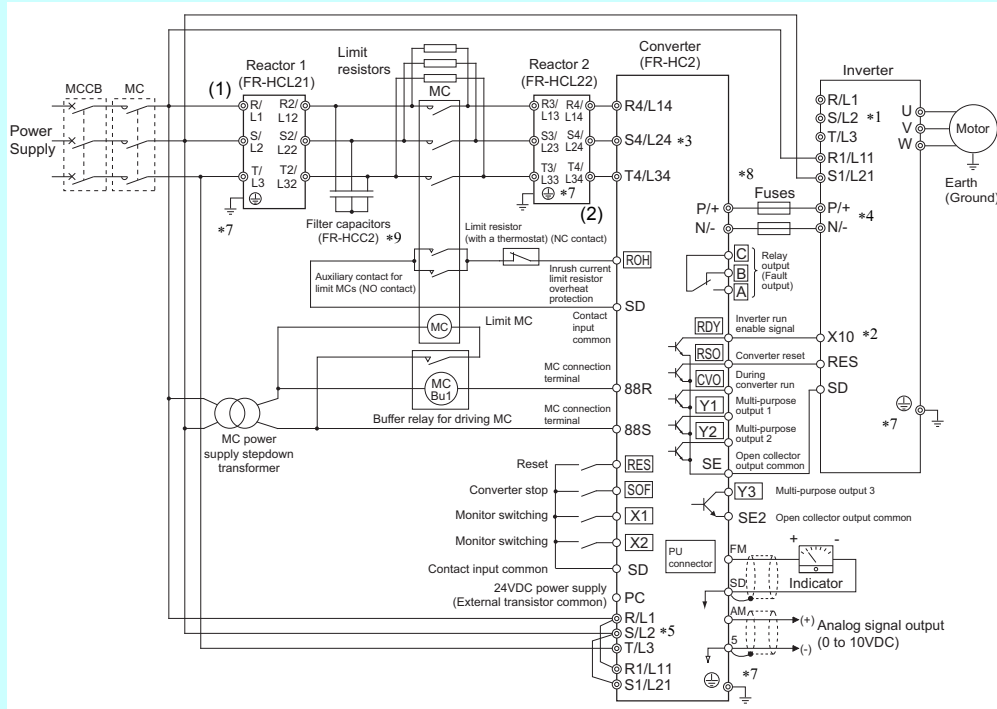

<<FR-HC2-H400K, H560K>>

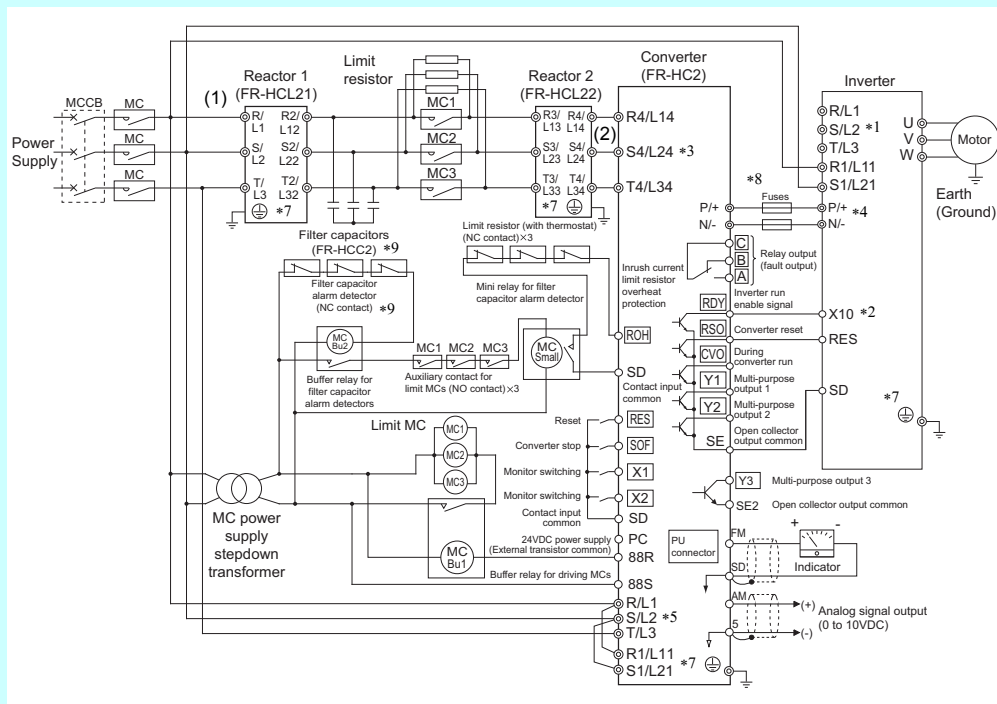

- *1 Do not connect anything to the inverter power input terminals R/L1, S/L2 and T/L3. Incorrect connection will damage the inverter. Connecting opposite polarity of terminals P/+ and N/- will damage the converter and the inverter.
- *2 Use input terminal function selection to assign the terminal used for the X10 signal.
- *3 The power phases of terminals R4/L14, S4/L24, and T4/L34 and terminals R/L1, S/L2, and T/L3 must be matched.
- *4 Do not insert MCCB between terminals P/+ and N/- (P and P, N and N).
- *5 Always connect terminal R/L1, S/L2, T/L3 of the converter to the power supply. If the inverter is operated without connecting the terminals to the power supply, the converter will be damaged.
- *6 Do not insert MCCB or MC between (1) (terminal R/L1, S/L2, and T/L3 input of the Reactor 1) and (2) (terminal R4/L14, S4/L24, and T4/L34 input of the converter) of the above diagram. It will not operate properly.
- *7 Securely perform grounding (earthing).
- *8 Installation of a fuse is recommended.
- *9 The quantity of the filter capacitor and the filter capacitor alarm detector depends on the inverter capacity.

Device	Quantity		
	280K	400K	560K
Filter capacitors	1	2	3
Filter capacitor alarm detector	—	2	3

Braking option

●Outline dimension drawings

(Unit: mm)

Voltage	Capacity	High Power Factor Converter FR-HC2			Reactor 1 FR-HCL21			Reactor 2 FR-HCL22			Outside Box FR-HCB2		
		W	H	D	W *1	H *1	D *1	W *1	H *1	D *1	W	H	D
200V	7.5K	220	260	170	132	150	100	237.5	230	140	190	320	165
	15K	250	400	190	162	172	126	257.5	260	165			
	30K	325	550	195	195	210	150	342.5	305	180	270	450	203
	55K	370	620	250	210	180	200.5	432.5	380	280			
	75K	465	620	300	240	215	215.5	474	460	280	400	450	250
400V	H7.5K	220	300	190	132	140	100	237.5	220	140			
	H15K	220	300	190	162	170	126	257.5	260	165	190	320	165
	H30K	325	550	195	182	195	101	342.5	300	180			
	H55K	370	670	250	282.5	245	165	392.5	365	200	270	450	203
	H75K	325	620	250	210	175	210.5	430	395	280	300	350	250
	H110K	465	620	300	240	230	220	500	440	370	350	450	380
	H160K	498	1010	380	280	295	274.5	560	520	430	400	450	440
	H220K	498	1010	380	330	335	289.5	620	620	480			
	H280K*2	680	1010	380	330	335	321	690	700	560	—	—	—
	H400K*2	790	1330	440	402	460	550	632	675	705	—	—	—
	H560K*2	790	1330	440	452	545	645	632	720	745	—	—	—

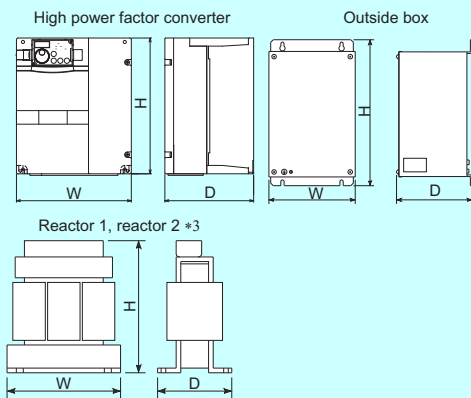

- *1 The sizes indicated by W, H, and D are not the sizes of legs. These indicate sizes of whole reactors only.
- *2 FR-HCB2 is not provided for H280K or higher. A filter capacitor and inrush current limit resistors are provided instead.
- *3 Install reactors (FR-HCL21 and 22) on a horizontal surface.

●Fuse

For safety, installation of a fuse is recommended between a high power factor converter and an inverter. Select a fuse according to the capacity of the connected motor. Select a fuse from the table below, and install it to the P side and the N side between the high power factor converter and the inverter.

<<Fuse selection table>>

Manufacturer: Mersen Japan K.K.

Contact: Sun-Wa Technos Corporation

- *1 Fuse holder (2 poles): US102 (without fuse light melting indicator) or US102I (with fuse light melting indicator)
- *2 When installing several fuses in parallel, leave a space of 12mm or more between the fuses.

<<200V class>>

Motor capacity (kW)	Rating (A)	Model
0.1	5	6.900 CP GR 10.38 0005 (FR10GR69V5) *1
0.2	10	6.900 CP GR 10.38 0010 (FR10GR69V10) *1
0.4	16	6.900 CP GR 10.38 0016 (FR10GR69V16) *1
0.75	20	6.900 CP GR 10.38 0020 (FR10GR69V20) *1
1.5	25	6.900 CP GR 10.38 0025 (FR10GR69V25) *1
2.2	50	6.9 URD 30 TTF 0050
3.7	63	6.9 URD 30 TTF 0063
5.5	100	6.9 URD 30 TTF 0100
7.5	125	6.9 URD 30 TTF 0125
11	160	6.9 URD 30 TTF 0160
15	200	6.9 URD 30 TTF 0200
18.5	250	6.9 URD 30 TTF 0250
22	315	6.9 URD 30 TTF 0315
30	400	6.9 URD 30 TTF 0400
37	500	6.9 URD 30 TTF 0500
45	630	6.9 URD 31 TTF 0630
55	700	6.9 URD 31 TTF 0700
75	800	6.9 URD 31 TTF 0800

<<400V class>>

Motor capacity (kW)	Rating (A)	Model
0.4	12.5	6.900 CP GR 10.38 0012.5 (FR10GR69V12.5) *1
0.75	16	6.900 CP GR 10.38 0016 (FR10GR69V16) *1
1.5	16	6.900 CP GR 10.38 0016 (FR10GR69V16) *1
2.2	20	6.900 CP GR 10.38 0020 (FR10GR69V20) *1
3.7	30	6.900 CP GR 10.38 0030 (FR10GR69V30) *1
5.5	50	6.9 URD 30 TTF 0050
7.5	50	6.9 URD 30 TTF 0050
11	80	6.9 URD 30 TTF 0080
15	125	6.9 URD 30 TTF 0125
18.5	125	6.9 URD 30 TTF 0125
22	160	6.9 URD 30 TTF 0160
30	200	6.9 URD 30 TTF 0200
37	250	6.9 URD 30 TTF 0250
45	315	6.9 URD 30 TTF 0315
55	350	6.9 URD 30 TTF 0350
75	450	6.9 URD 30 TTF 0450
90	500	6.9 URD 30 TTF 0500
110	550	6.9 URD 31 TTF 0550

Motor capacity (kW)	Rating (A)	Model
132	630	6.9 URD 31 TTF 0630
160	800	6.9 URD 31 TTF 0800
185	900	6.9 URD 32 TTF 0900
220	1000	6.9 URD 32 TTF 1000 or 6.9 URD 31 TTF 0630 × 2 in parallel *2
250	1250	6.9 URD 33 TTF 1250 or 6.9 URD 31 TTF 0700 × 2 in parallel *2
280	1400	6.9 URD 33 TTF 1400 or 6.9 URD 31 TTF 0800 × 2 in parallel *2
315	1600	6.9 URD 232 TTF 1600 or 6.9 URD 31 TTF 0800 × 2 in parallel *2
355	1800	6.9 URD 232 TTF 1800 or 6.9 URD 32 TTF 0900 × 2 in parallel *2
400	1800	6.9 URD 232 TTF 1800 or 6.9 URD 32 TTF 0900 × 2 in parallel *2
450	2500	6.9 URD 33 TTF 1250 × 2 in parallel *2
500	2700	6.9 URD 32 TTF 0900 × 3 in parallel *3
560	2700	6.9 URD 32 TTF 0900 × 3 in parallel *2

Noise filter

Line noise filter

FR-BSF01 ALL FR-BLF ALL

RC5128ZZ (introduced product) A800 A800 Plus F800 A701

A filter is used to suppress radio noise and line noise emitted from the inverter power supply side or output side.

Introduced product: RC5128ZZ Manufacturer: Soshin Electric Co., Ltd.

Specifications

Model	FR-BSF01				FR-BLF				RC5128ZZ (introduced product)		
Applicable inverter capacity	For small capacity inverter *1				For general inverter *1				For large capacity inverter *1		
Compatible wire size (mm ²)	2, 3.5	5.5	8, 14	22	2 to 22	30 to 60	80	100 to 150	100 to 125	150 to 200	250
Number of times of wire to be passed through (T)	4	3	2	1	4	3	2	1	3	2	1
Improvement effect	Greater effect between 0.5 to 5MHz. The greater the number of turns, the more effective result is obtained.										
Rated input AC power supply	Three phase 200V 50Hz/three phase 200/220V 60Hz Three phase 400V 50Hz/three phase 400/440V 60Hz										
Approximate mass (kg)	0.2				1.2				1.1		



FR-BLF

- *1 Used up to the cable thickness (applicable wire size) less than the size of wire passing hole.
- *2 For the 55K or lower models of the FR-A800, FR-A800 Plus, and FR-F800 series inverters, a corresponding appliance (common mode choke) is built-in on the input side.

Connection diagram

- Ensure that each phase is wound one time in the same direction.
- When connecting to the input side, it is recommended that the wire should be turned three times or more (4T, 4 turns). The greater the number of turns, the more effective result is obtained.
- When using several line noise filters to make 4T or more, wind the phases (cables) together. Do not use different line noise filter for different phases.
- When using filters at the output side, do not wind the cable more than 3 times (4T) for each filter because the filter may overheat.
- Do not wind earthing cable.
- When the wire size is too thick to wind, use more than four filters in series.

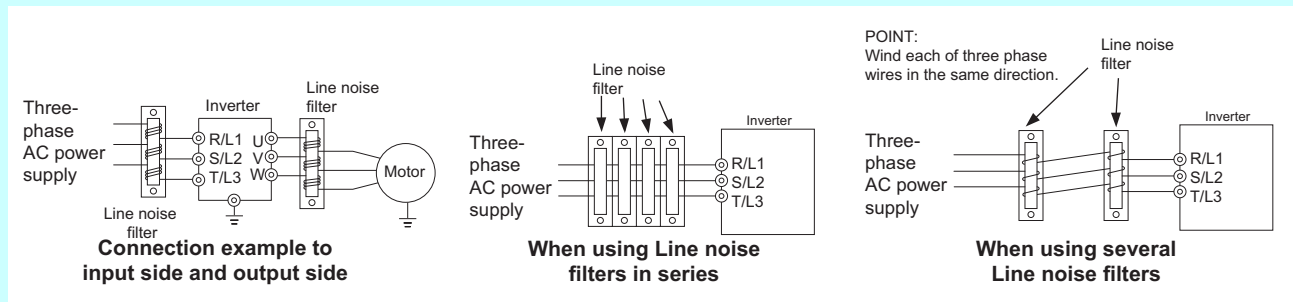

Outline dimension drawings

<<FR-BSF01>>

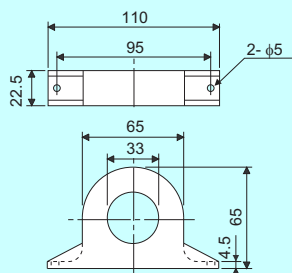

<<FR-BLF>>

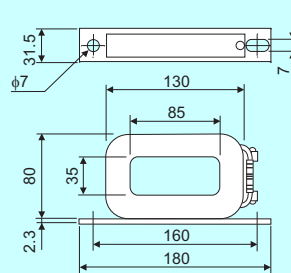

<<RC5128ZZ (introduced product)>>

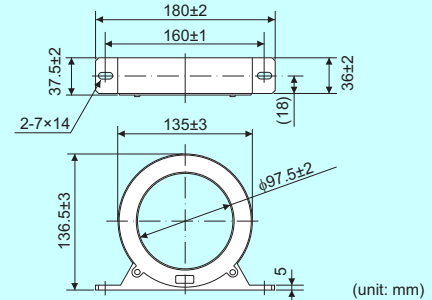

(unit: mm)

Radio noise filter

FR-BIF E700 F700PJ D700

A filter is used to suppress radio noise emitted from the inverter power supply side.

●Specifications

Type	200V	400V
	FR-BIF	FR-BIF-H
Applicable inverter capacity	Usable regardless of the inverter capacity *	
Improvement effect	Greater effect at 10MHz or less (note that the effect differs according to region.)	
Rated input AC power supply	Three phase 200V 50Hz/ three phase 200/220V 60Hz	Three-phase 400V 50Hz/ three phase 400/440V 60Hz
Approximate mass (kg)	0.1	0.1



FR-BIF-H

* For the FR-A800, FR-A800 Plus, or FR-F800 series inverter, a corresponding filter (capacitive filter) is

●Connection diagram

- Connect to the inverter input side. Connect the filter directly to the inverter input terminal.
- Since long connection wire reduces effect, the wire length should be minimized. Make sure to perform earthing with resistance of 100Ω or less.
- When the filter is used in the inverter with the single-phase power input specification, cut the T-phase wire as short as possible and insulate the cut end securely.
- The maximum leakage current is about 4mA (8mA for the 400V class). (The leakage current is equivalent to the current for one phase of the three-phase three-wire star-connection power supply.)

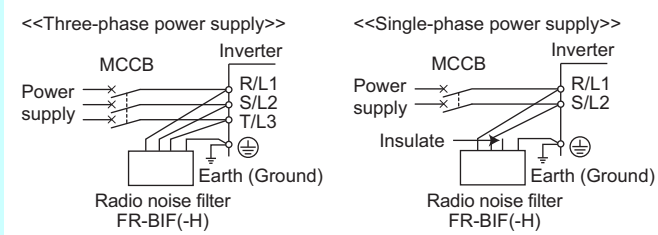

●Outline dimension drawings

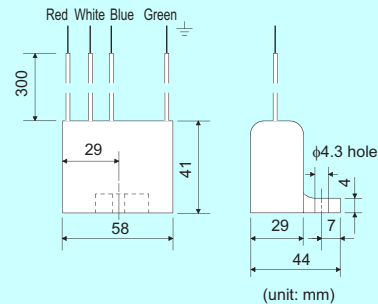

EMC Directive compliant EMC filter

FR-E5NF E700 F700PJ D700 SF□□ E700 F700PJ D700 FR-S5NFSA E700 D700

This EMC filter complies with the EU EMC Directive.

●Selection

- Select a filter in accordance with the inverter type

FR-E700 Series Inverter Model		EMC Filter Model
Single phase 100V class	FR-E710W-0.1K to 0.4K	FR-S5NFSA-0.75K
	FR-E710W-0.75K	FR-S5NFSA-1.5K
Single phase 200V class	FR-E720S-0.1K to 0.4K	SF1320
	FR-E720S-0.75K	SF1321
	FR-E720S-1.5K	FR-S5NFSA-1.5K
	FR-E720S-2.2K	SF1309
200V class	FR-E720-0.1K to 1.5K	SF1306
	FR-E720-2.2K, 3.7K	SF1309
	FR-E720-5.5K to 11K	SF1260
	FR-E720-15K	SF1261
400V class	FR-E740-0.4K, 0.75K	FR-E5NF-H0.75K
	FR-E740-1.5K to 3.7K	FR-E5NF-H3.7K
	FR-E740-5.5K, 7.5K	FR-E5NF-H7.5K
	FR-E740-11K, 15K	SF1175

FR-D700 Series Inverter Model		EMC Filter Model
Single phase 100V class	FR-D710W-0.1K to 0.4K	FR-S5NFSA-0.75K
	FR-D710W-0.75K	FR-S5NFSA-1.5K
Single phase 200V class	FR-D720S-0.1K to 0.75K	FR-S5NFSA-0.75K
	FR-D720S-1.5K	FR-S5NFSA-1.5K
	FR-D720S-2.2K	SF1309
	FR-D720-0.1K to 1.5K	SF1306
200V class	FR-D720-2.2K, 3.7K	SF1309
	FR-D720-5.5K to 11K	SF1260
	FR-D720-15K	SF1261
	400V class	FR-D740-0.4K, 0.75K
FR-D740-1.5K to 3.7K		FR-E5NF-H3.7K
FR-D740-5.5K, 7.5K		FR-E5NF-H7.5K
FR-D740-11K, 15K		SF1175

FR-F700PJ Series Inverter Model		EMC Filter Model
200V class	FR-F720PJ-0.4K to 1.5K	SF1306
	FR-F720PJ-2.2K, 3.7K	SF1309
	FR-F720PJ-5.5K to 11K	SF1260
	FR-F720PJ-15K	SF1261
400V class	FR-F740PJ-0.4K, 0.75K	FR-E5NF-H0.75K
	FR-F740PJ-1.5K to 3.7K	FR-E5NF-H3.7K
	FR-F740PJ-5.5K, 7.5K	FR-E5NF-H7.5K
	FR-F740PJ-11K, 15K	SF1175

● Connection diagram

· Connect to the inverter input side. Refer to EMC Installation Guidelines (BCN-A21041-202/204) for details of wiring method.

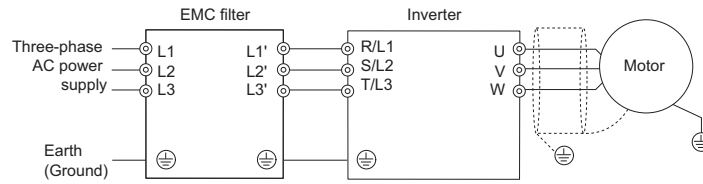

Connection diagram of three-phase power supply

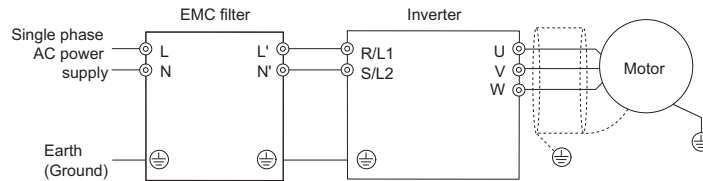

Connection diagram of single-phase power supply

* Take the following measures to prevent a peripheral device malfunction or electric shock accident from occurring due to a leakage current.

- 1) Ground (earth) the EMC filter before connecting the power supply. In that case, make certain that grounding (earthing) is securely performed via the grounding (earthing) part of the panel.
- 2) Select the earth leakage circuit breaker or earth leakage relay in consideration of the EMC filter's leakage current. A leakage current breaker may not be used when leakage current of EMC filter become large. When using an earth leakage relay which has great sensitivity current or when not using a leakage circuit breaker and earth leakage relay, connect the equipment to the earth securely as shown in 1).

● Outline dimension drawings

EMC Filter Model		Outline Dimension			Approximate Mass (kg)	Leakage Current Reference Value (mA)
		W	H	D		
Single phase 100V	FR-S5NFA-0.75K	70	168	35	0.7	4.5
Single phase 200V	FR-S5NFA-1.5K	110	168	35	1.1	9.5
Single phase 200V	SF1320	70	168	30.5	0.4	10
	SF1321	110	168	36.5	0.6	10
Three phase 200V	SF1259	142	410	65	2.4	33
	SF1265	468	913	110	22	1500
	SF1306	110	200	36.5	0.7	10
	SF1309	200	282	57	2.1	15
Three phase 400V	SF1197	144	360	47.5	1.5	57
	SF1174B	213	360	38	1.8	51
	FR-E5NF-H0.75K	140	210	46	1.1	22.6
	FR-E5NF-H3.7K	140	210	46	1.2	44.5
	FR-E5NF-H7.5K	220	210	47	2	68.4

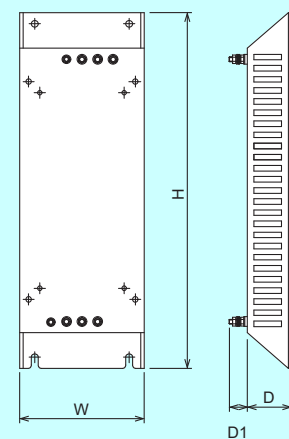
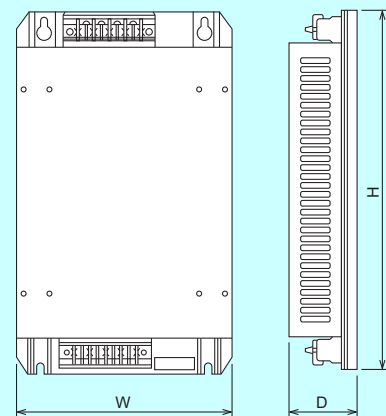

EMC Filter Model		Outline Dimension				Approximate Mass (kg)	Leakage Current Reference Value (mA)
		W	H	D	D1		
Three phase 200V	SF1260	222	468	80	39	5	440
	SF1261	253	600	86	38	9.3	71
	SF1262	303	650	86	47	11	71
	SF1263	327	730	86	47	15	71
Three phase 400V	SF1175	253	530	60	35	4.7	76
	SF1176	303	600	60	38	5.9	108
	SF1177	327	700	80	38	9.4	156
	SF1178	450	770	80	47	16	156
	SF1179	467	920	80	46	19	156

- *1 The indicated leakage current is equivalent to the current for one phase of the three-phase three-wire star-connection power supply. For the three-phase three-wire delta-connection power supply, the value becomes approximately three times larger than the listed value.
- *2 An installation intercompatibility attachment and an EMC filter installation attachment may be necessary to install the inverter. In such a case, note that the width equivalent to the intercompatibility attachment length increases.

Filterpack

FR-BFP2 E700 F700PJ D700

Filterpack is enclosed for the FR-F7□0PJ-□KF inverters.

Power factor improving AC reactor, common mode choke, and capacitor type filter are combined into one as Filterpack. Using the option, the inverter may conform to the Japanese guideline for reduction of harmonic emission.

The option is available for three-phase 200V/400V class inverters with 0.4K to 15K capacity.

Filterpack can be installed on the side or on the rear. (Rear panel installation is not available for FR-E720-5.5K, 7.5K, and FR-E740-0.4K to 3.7K.)

●Specifications

<<For three-phase 200V class>>

Model FR-BFP2-□K		0.4	0.75	1.5	2.2	3.7	5.5	7.5	11	15
Permissible inverter output current (A) *1		2.5	4.2	7	10	16.5	23.8	31.8	45	58
Approximate mass (kg)		1.3	1.4	2.0	2.2	2.8	3.8	4.5	6.7	7.0
Power factor improving reactor		Install a DC reactor on the DC side. (93% to 95% of power supply power factor under 100% load (94.4% *2))								
Noise filter	Common mode choke	Install a ferrite core on the input side.								
	Capacitive filter	About 4mA of capacitor leakage current *3								
Protective structure (JEM1030)		Open type (IP00)								



<<For three-phase 400V class>>

Model FR-BFP2-H□K		0.4	0.75	1.5	2.2	3.7	5.5	7.5	11	15
Permissible inverter output current (A) *1		1.2	2.2	3.7	5	8.1	12	16.3	23	29.5
Approximate mass (kg)		1.6	1.7	1.9	2.3	2.6	4.5	5.0	7.0	8.2
Power factor improving reactor		Install a DC reactor on the DC side. (93% to 95% of power supply power factor under 100% load (94.4% *2))								
Noise filter	Common mode choke	Install a ferrite core on the input side.								
	Capacitive filter	About 8mA of capacitor leakage current *3								
Protective structure (JEM1030)		Open type (IP00)								

- *1 To use with an FR-E700 series inverter, select a capacity that makes the load (inverter output) current to be the same with the permissible inverter output current or lower.
- *2 The values in parentheses are calculated by applying 1 power factor to the reference waveform in accordance with the Architectural Standard Specifications (Electrical Installation) (2013 revisions) supervised by the Ministry of Land, Infrastructure, Transport and Tourism of Japan.)
- *3 The indicated leakage current is equivalent to the current for one phase of the three-phase three-wire star-connection power supply.

●Connection diagram

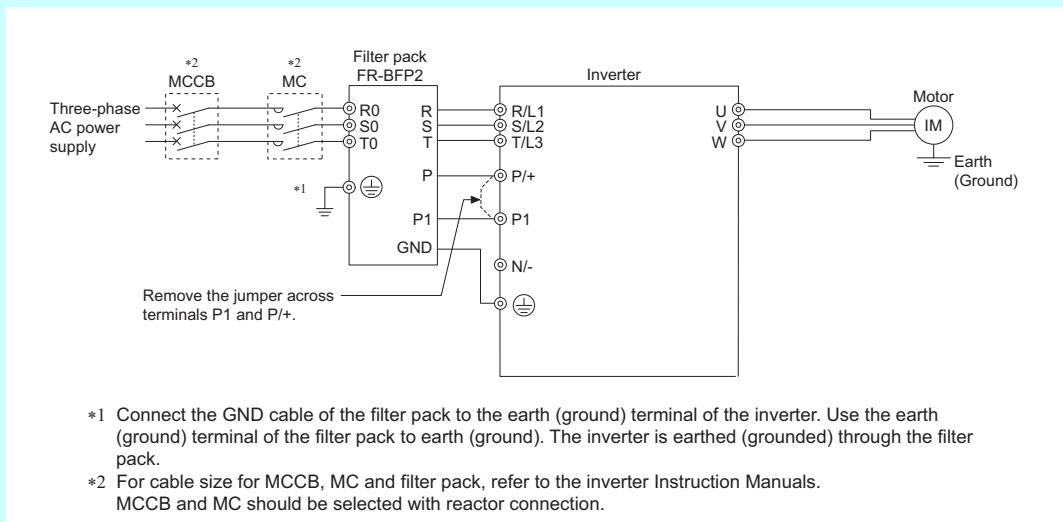

●Outline dimension drawings

- FR-BFP2-0.4K to 3.7K
- FR-BFP2-H0.4K to H3.7K

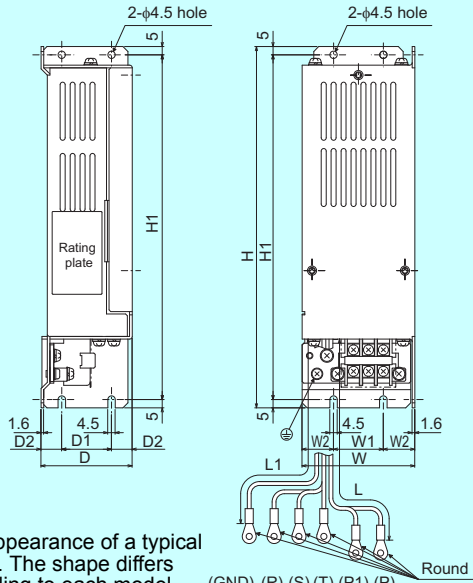

The appearance of a typical model. The shape differs according to each model.

(GND) (R) (S) (T) (P1) (P)

Round crimping terminal φ4.3

- FR-BFP2-5.5K to 15K
- FR-BFP2-H5.5K to H15K

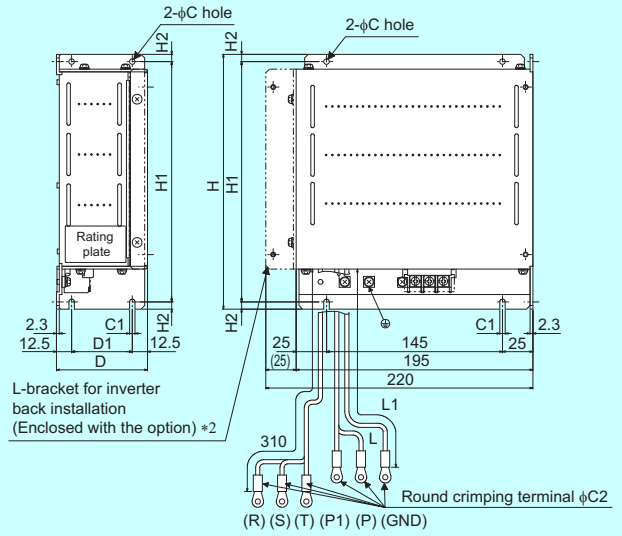

L-bracket for inverter back installation (Enclosed with the option) *2

Round crimping terminal φC2 (R) (S) (T) (P1) (P) (GND)

(Unit: mm)

	Capacity	W	W1	W2	H	H1	D	D1	D2	L	L1
200V	0.4K, 0.75K	68	30	19	218	208	60	30	15	240	220
	1.5K, 2.2K	108	55	26.5	188	178	80	55	12.5	200	220
	3.7K	170	120	25	188	178	65	40	12.5	220	240
400V	H0.4K, H0.75K *1	108	55	26.5	188	178	55	30	12.5	200	220
	H1.5K to H3.7K	108	55	26.5	188	178	80	55	12.5	200	220

	Capacity	W	W1	W2	H	H1	D	D1	D2	L	L1
200V	5.5K, 7.5K	210	198	6	75	50	4.5	4.5	5.3	270	400
	11K	320	305	7.5	85	60	6	6	5.3	280	280
	15K	320	305	7.5	85	60	6	6	6.4	260	260
400V	H5.5K, H7.5K	210	198	6	75	50	4.5	4.5	4.3	270	400
	H11K	320	305	7.5	85	60	6	6	4.3	280	280
	H15K	320	305	7.5	85	60	6	6	6.4	260	260

*1 The 400V class H0.4K and H0.75K have no slit.

*2 L-bracket is required to install the option to the back of inverter.

L-bracket is not attached when shipped from the factory but is enclosed with the option.

Output filter

Surge voltage suppression filter FR-ASF, FR-BMF A800 A800 Plus F800 E700 F700PJ D700

A surge voltage suppression filter limits surge voltage applied to motor terminals when driving the 400V class motor by the inverter. This filter cannot be used under vector control, Real sensorless vector control, and IPM motor control.

● Specifications

Model FR-ASF-□	400V						
	H1.5K	H3.7K	H7.5K	H15K	H22K	H37K	H55K
Applicable motor capacity (kW)	0.4 to 1.5	2.2 to 3.7	5.5 to 7.5	11 to 15	18.5 to 22	30 to 37	45 to 55
Rated input current (A)	4.0	9.0	17.0	31.0	43.0	71.0	110.0
Rated input AC voltage	Three-phase 380V to 460V 50/60Hz						
Maximum AC voltage fluctuation	Three-phase 506V 50Hz/60Hz						
Maximum frequency	400Hz						
PWM frequency permissible range	0.5kHz to 14.5kHz						
Maximum wiring length between the filter-motor	300m						
Approximate mass (kg)	8.0	11.0	20.0	28.0	38.0	59.0	78.0

Model FR-BMF-□	400V			
	H7.5K	H15K	H22K	H37K
Applicable motor capacity (kW)	5.5 to 7.5	11 to 15	18.5 to 22	30 to 37
Rated input current (A)	17.0	31.0	43.0	71.0
Rated input AC voltage	Three-phase 380 to 480V 50Hz/60Hz			
Maximum AC voltage fluctuation	Three-phase 323 to 528V 50Hz/60Hz			
Maximum AC voltage fluctuation	120Hz			
PWM frequency permissible range	2kHz or less *			
Maximum wiring length between the filter-motor	100m			
Approximate mass (kg)	5.5	9.5	11.5	19

* Always set the inverter PWM frequency to 2kHz or less.

● Connection diagram

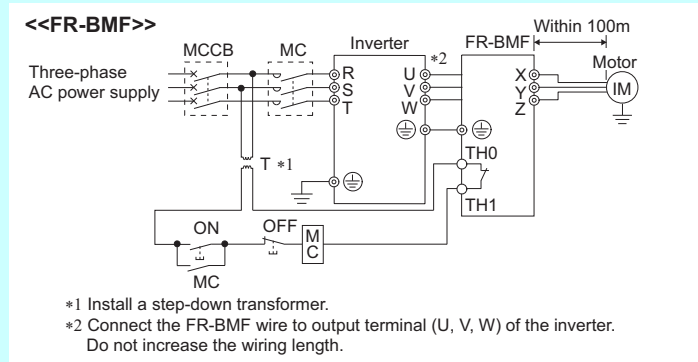
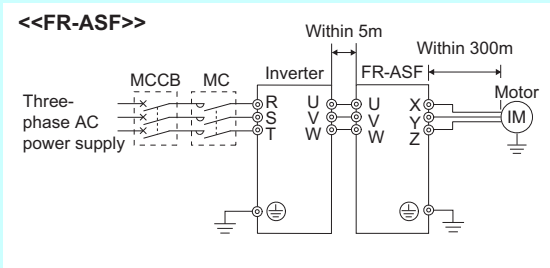

<<FR-ASF>>

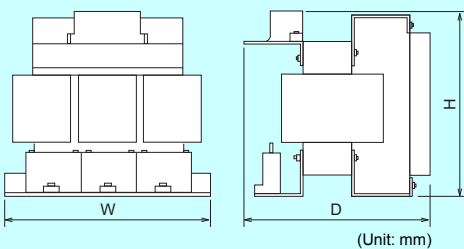

Surge Voltage Suppression Filter Model	W	H *1	D *1
FR-ASF-H1.5K	220	193	160
FR-ASF-H3.7K	220	200	180
FR-ASF-H7.5K	280	250	215
FR-ASF-H15K *2	335	260	285
FR-ASF-H22K *2	335	340	349
FR-ASF-H37K *2	375	445	388
FR-ASF-H55K *2	395	445	568

*1 Maximum size
*2 For the H15K or higher, the shape is partially different.

<<FR-BMF>>

● FR-BMF-H7.5K to H22K

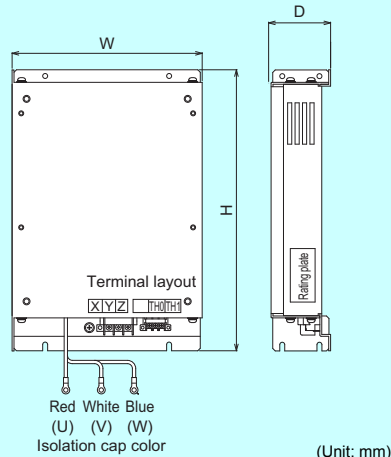

Surge Voltage Suppression Filter Model	W	H	D
FR-BMF-H7.5K	230	340	75
FR-BMF-H15K, H22K	260	500	100

● FR-BMF-H37K

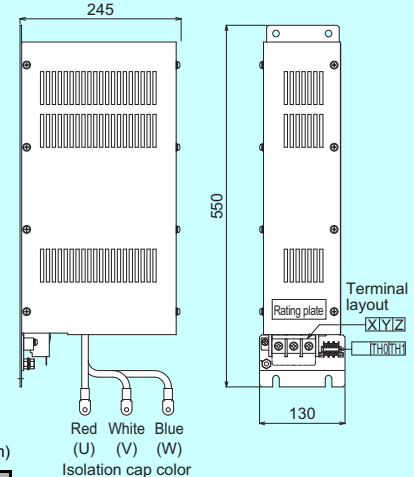

Sine wave filter

MT-BSL, MT-BSC A800 A800 Plus F800 A701

Installing the sine wave filter on the inverter output side converts the motor voltage/current into a nearly sine wave. Effects such as 1) acoustic noise reduction, 2) surgeless, and 3) reduction of the motor loss (use of standard motor) could be expected. Always use this filter under V/F control.

● Specifications

Model	200V		400V				
	MT-BSL-□□	75K	90K	H75K	H110K	H150K	H220K
MT-BSC-□□	75K	90K	H75K	H110K	—	—	—
Maximum frequency	60Hz						
PWM frequency permissible range	2.5kHz ±1						
Vibration	5.9m/s ² or less, 10 to 55Hz (directions of X, Y, Z axes)						
Approximate mass (kg)	Refer to the outline dimension drawing.						

*1 Always set the inverter PWM frequency to 2.5kHz.

● Selection

- Select the inverter whose capacity is one rank larger in size of the motor capacity as stated in the table below. Note that an inverter with same kW with a motor can be used if the rated motor current × 1.1 is less than 90% of the inverter rated current.
- Use the MT-BSL-HC when using a sine wave filter with the FR-HC2.

Motor Capacity (kW)	Model	
	Reactor for filter	Capacitor for filter *1
200V class	75	MT-BSL-75K 1 × MT-BSC-75K
	90	MT-BSL-90K 1 × MT-BSC-90K
400V class	75	MT-BSL-H75K(-HC) 1 × MT-BSC-H75K
	90	MT-BSL-H110K(-HC) 1 × MT-BSC-H110K
	110	MT-BSL-H110K(-HC) 1 × MT-BSC-H110K
	132	MT-BSL-H150K(-HC) 2 × MT-BSC-H75K
	160	MT-BSL-H220K(-HC) 2 × MT-BSC-H110K
	185	MT-BSL-H220K(-HC) 2 × MT-BSC-H110K
	220	MT-BSL-H220K(-HC) 2 × MT-BSC-H110K
	250	MT-BSL-H280K(-HC) 3 × MT-BSC-H110K
280	MT-BSL-H280K(-HC) 3 × MT-BSC-H110K	

*1 When using several capacitors for filter, connect them in parallel as in the connection diagram.

● Connection diagram

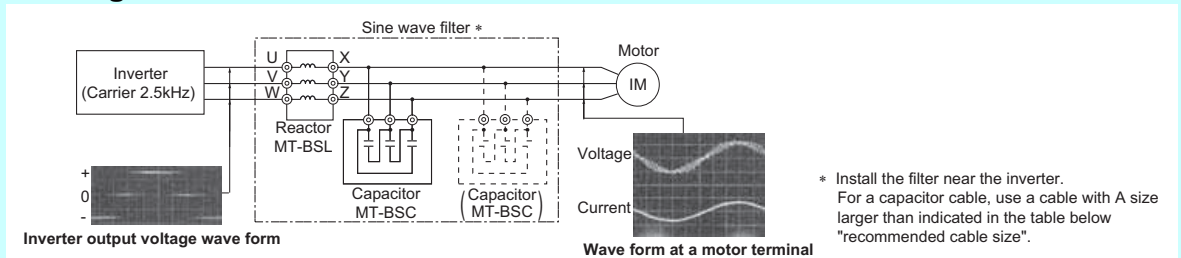

● Outline dimension drawings

- The appearance of a typical model. The shape differs according to each model.

<<MT-BSL>>

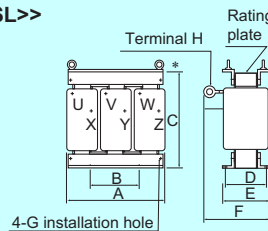

<<MT-BSC>>

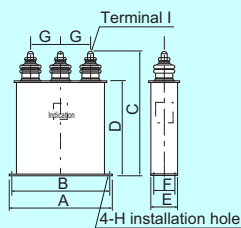

Model		A	B	C	D	E	F	G	H	Mass (kg)
200V class	MT-BSL-75K	330	150	285	185	216	328	M10	M12	80
	MT-BSL-90K	390	150	320	180	220	330	M12	M12	120
400V class	MT-BSL-H75K	330	150	285	185	216	318	M10	M10	80
	MT-BSL-H110K	390	150	340	195	235	368	M12	M12	140
	MT-BSL-H150K	455	200	397	200	240	380	M12	M12	190
	MT-BSL-H220K	495	200	405	250	300	420	M12	M12	240
	MT-BSL-H280K	575	200	470	310	370	485	M12	M12	340
	MT-BSL-H75K-HC	385	150	345	185	216	315	M10	M10	110
	MT-BSL-H110K-HC	420	170	400	195	235	370	M12	M12	180
	MT-BSL-H150K-HC	450	300	455	390	430	500	M12	M12	250
MT-BSL-H220K-HC	510	350	540	430	485	555	M12	M12	310	
MT-BSL-H280K-HC	570	400	590	475	535	620	M12	M12	480	

Model		A	B	C	D	E	F	G	H	I	Mass (kg)
200V class	MT-BSC-75K	207	191	285	233	72	41	45	φ7	M8	3.9
	MT-BSC-90K	282	266	240	183	92	56	85	φ7	M12	5.5
400V class	MT-BSC-H75K	207	191	220	173	72	41	55	φ7	M6	3.0
	MT-BSC-H110K	207	191	280	233	72	41	55	φ7	M6	4.0

* Leave more than 25mm space between capacitors.

Recommended cable size

The cable sizes between the Inverter and MT-BSL and between the MT-BSL and IM should be the same as the U, V, W wiring size. The cable size to the MT-BSC is as table below.

MT-BSC-75K	MT-BSC-90K	MT-BSC-H75K	MT-BSC-H110K
38mm ²	38mm ²	22mm ²	22mm ²

Structure option

Panel through attachment

FR-A8CN (A800, A800 Plus, F800)
FR-E7CN (E700, F700PJ, D700)

With this attachment, the heatsink, which is the exothermic section of the inverter, can be placed outside of the enclosure. Since the heat generated in the inverter can be radiated to the rear of the enclosure, the enclosure can be downsized.

● Selection

Attachment Model	Applicable Inverter			
	FR-A820	FR-A840	FR-F820	FR-F840
FR-A8CN01	00105(1.5K), 00167(2.2K), 00250(3.7K)	00023(0.4K), 00038(0.75K), 00052(1.5K), 00083(2.2K), 00126(3.7K)	00105(2.2K), 00167(3.7K), 00250(5.5K)	00023(0.75K), 00038(1.5K), 00052(2.2K), 00083(3.7K), 00126(5.5K)
FR-A8CN02	00340(5.5K), 00490(7.5K)	00170(5.5K), 00250(7.5K)	00340(7.5K), 00490(11K)	00170(7.5K), 00250(11K)
FR-A8CN03	00630(11K)	00310(11K), 00380(15K)	00630(15K)	00310(15K), 00380(18.5K)
FR-A8CN04	00770(15K), 00930(18.5K), 01250(22K)	00470(18.5K), 00620(22K)	00770(18.5K), 00930(22K), 01250(30K)	00470(22K), 00620(30K)
FR-A8CN05	01540(30K)	00770(30K)	01540(37K)	00770(37K)
FR-A8CN06	01870(37K), 02330(45K)	00930(37K), 01160(45K), 01800(55K)	01870(45K), 02330(55K)	00930(45K), 01160(55K), 01800(75K)
FR-A8CN07	03160(55K)	—	03160(75K)	—
FR-A8CN08	03800(75K), 04750(90K)	03250(110K), 03610(132K)	03800(90K), 04750(110K)	03250(132K), 03610(160K)
FR-A8CN09	—	02160(75K), 02600(90K)	—	02160(90K), 02600(110K)

Attachment Model	Applicable Inverter					
	FR-E700		FR-F700PJ		FR-D700	
	200V class	400V class	200V class	400V class	200V class	400V class
FR-E7CN01	FR-E720-1.5K, 2.2K FR-E720S-0.75K, 1.5K	—	FR-F720PJ-1.5K, 2.2K	FR-F740PJ-1.5K to 3.7K	FR-D720-1.5K, 2.2K FR-D720S-1.5K	FR-D740-1.5K to 3.7K
FR-E7CN02	FR-E720-3.7K	—	FR-F720PJ-3.7K	—	FR-D720-3.7K	—
FR-E7CN03	FR-E720-5.5K, 7.5K	—	—	—	—	—
FR-E7CN04	FR-E720S-2.2K	FR-E740-1.5K to 3.7K	—	—	FR-D720S-2.2K	—
FR-E7CN05	—	FR-E740-5.5K, 7.5K	FR-F720PJ-5.5K, 7.5K	FR-F740PJ-5.5K, 7.5K	FR-D720-5.5K, 7.5K	FR-D740-5.5K, 7.5K
FR-E7CN06	FR-E720-11K, 15K	FR-E740-11K, 15K	FR-F720PJ-11K, 15K	FR-F740PJ-11K, 15K	FR-D720-11K, 15K	FR-D740-11K, 15K

● Outline dimension drawings

- This attachment requires larger area for attachment.

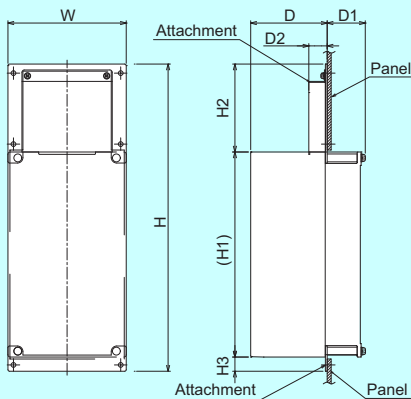

(Unit: mm)

Type	W	H	H1	H2	H3	D	D1	D2
FR-A8CN01	150	389.5	260	111.5	18	97	48.4	24.3
FR-A8CN02	245	408.5	260	116.5	32	86	89.4	21.3
FR-A8CN03	245	448.5	300	116.5	32	89	106.4	21.3
FR-A8CN04	280	554	400	113.5	32	96.7	102.4	40.6
FR-A8CN05	357	654	480	130	44	130.8	64.2	105
FR-A8CN06	478.2	650	465	145	40	96	154	55
FR-A8CN07	510.2	805	610	150	45	130	120	105
FR-A8CN08	510.2	845	650	150	45	176.5	183.5	40
FR-A8CN09	510.2	725	530	150	45	152.3	147.7	65

Totally-enclosed structure attachment

FR-E7CV E700

Installing the attachment to the inverter changes the protective structure (JEM1030) of the inverter to the totally enclosed structure (IP40 equivalent).

●Specifications

Item	Description
Surrounding air temperature	-10°C to +40°C
Ambient humidity	90% RH or less (non-condensing)
Atmosphere	Indoors (free from corrosive gas, flammable gas, oil mist, dust and dirt)
Altitude	Maximum 1,000m
Vibration	5.9m/s ² or less at 10 to 55Hz (directions of X, Y, Z axes)

●Selection

Attachment Model	Applicable Inverter
	FR-E700
FR-E7CV01	FR-E720-0.1K to 0.75K
FR-E7CV02	FR-E720-1.5K, 2.2K
FR-E7CV03	FR-E720-3.7K
FR-E7CV04	FR-E720-5.5K, 7.5K

Control circuit terminal block intercompatibility attachment

FR-A8TAT A800 A800 Plus F800

This attachment allows the conventional 700/500 series control circuit terminal blocks to be installed without removing any cables. This attachment is useful for replacing a conventional inverter with the 800 series inverter.

●Installation procedure

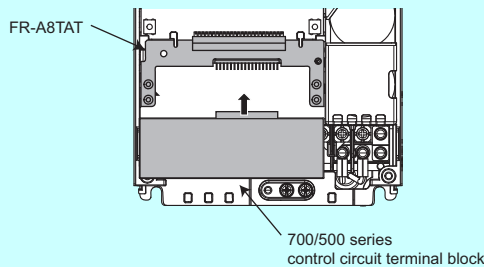

●Restrictions

- For using the control circuit terminal block of the 500 series, open or remove the cover of the control circuit terminal block. Otherwise, the front cover of the inverter may not close properly.
- Since the specifications of the control circuit terminals of the 700/500 series are different from those of the 800 series, certain functions of the inverter are restricted (refer to the table below).

	Relay output 2 terminals	24V external power supply input terminal	Safety stop signal terminals
FR-A500/F500 series	×	×	×
FR-A700/F700(P) series	○	×	×

○...Available, ×...Not available

- The FR-A8NC, FR-A8NCE, or FR-A8NS plug-in option cannot be installed.
- When using a plug-in option, connect the plug-in option using a cable that can be routed through the space between the front cover and the control circuit terminal block (700 series: 7mm, 500 series: 0.8mm).

Structure option

Intercompatibility attachment EMC filter installation attachment

FR-AAT, FR-A5AT (A800) (A800 Plus) (F800)

FR-E7AT (E700)

FR-E5T (E700) (F700PJ) (D700)

FR-F8AT (F800) (For FR-F820-75K)

When replacing with a new inverter, the attachment make the new inverter to be installed using holes of conventional model.

●Specifications

Attachment Model	Installation Size of Mountable Model (W×H unit mm)				Installation Size of Compatible Conventional Model (W×H unit mm)
FR-AAT01	1) 95 × 245	2) 125 × 245	3) 95 × 285	4) 125 × 285	200 × 280
FR-AAT02	1) 125 × 245	2) 195 × 245	3) 125 × 285	4) 195 × 285	230 × 380
FR-AAT03	1) 195 × 285	2) 230 × 380			230 × 510
FR-AAT04	1) 195 × 285	2) 230 × 380	3) 280 × 430		290 × 570
FR-AAT05	1) 230 × 380	2) 280 × 430	3) 270 × 530		290 × 670
FR-AAT06	1) 270 × 530	2) 380 × 525			420 × 720
FR-AAT07	1) 380 × 525	2) 410 × 675			420 × 860
FR-AAT08	1) 380 × 525				420 × 860
FR-AAT09	1) 270 × 530				380 × 525
FR-AAT21	1) 95 × 245				125 × 245
FR-AAT22	1) 125 × 245				195 × 245
FR-AAT23	1) 270 × 530				380 × 525
FR-AAT24	1) 195 × 285				230 × 380
FR-AAT27	1) 230 × 380				270 × 530
FR-A5AT01	1) 95 × 245				95 × 285
FR-A5AT02	1) 95 × 245	2) 125 × 245			125 × 285
FR-A5AT03	1) 125 × 245	2) 195 × 245			195 × 285
FR-A5AT04	1) 195 × 285	2) 230 × 380			280 × 430
FR-A5AT05	1) 380 × 525				410 × 675
FR-E5T *	1) 96 × 118	2) 158 × 118			188 × 138
FR-E5T-02 *	1) 164 × 244				195 × 285

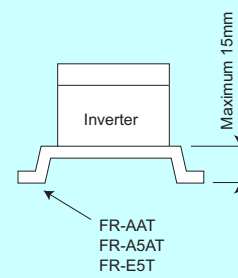

The depth increases after installation of the inverter when the attachment is used.

*1 This is sold as the FR-E700 series, F700PJ series and D700 series attachment with EMC filter.

●Selection

<<List of replacement with FR-A820>>

Model name and capacity of conventional model		FR-A820								
		0.4K/0.75K	1.5K to 3.7K	5.5K/7.5K	11K	15K to 22K	30K	37K/45K	55K	
FR-A220E	0.4K/0.75K	FR-A5AT01	—	—	—	—	—	—	—	
	1.5K to 3.7K	FR-A5AT02	FR-A5AT02	—	—	—	—	—	—	
	5.5K to 11K	—	FR-A5AT03	FR-A5AT03	○	—	—	—	—	
	15K	—	—	FR-AAT02	FR-AAT24	○	—	—	—	
	18.5K/22K	—	—	—	FR-A5AT04	FR-A5AT04	—	—	—	
	30K	—	—	—	—	FR-AAT27	○	—	—	
	37K/45K	—	—	—	—	—	FR-AAT23	○	—	
	55K	—	—	—	—	—	—	FR-A5AT05	○	
FR-A520/A720	0.4K/0.75K	○	—	—	—	—	—	—	—	
	1.5K to 3.7K	FR-AAT21	○	—	—	—	—	—	—	
	5.5K/7.5K	—	FR-AAT22	○	—	—	—	—	—	
	11K	—	—	FR-A5AT03	○	—	—	—	—	
	15K to 22K	—	—	—	FR-AAT24	○	—	—	—	
	30K	—	—	—	—	FR-AAT27	○	—	—	
	37K/45K	—	—	—	—	—	FR-AAT23	○	—	
	55K	—	—	—	—	—	—	FR-A5AT05	○	

○: Mountable without an intercompatibility attachment

FR-A5AT□□, FR-AAT□□: Easily replaceable with a stated intercompatibility attachment.

<<List of replacement with FR-A840>>

Model name and capacity of conventional model		FR-A840						
		0.4K to 3.7K	5.5K/7.5K	11K/15K	18.5K/22K	30K	37K to 55K	
Model name and capacity of conventional model	FR-A240E	0.4K to 3.7K	FR-A5AT02	—	—	—	—	—
		5.5K/7.5K	FR-A5AT03	FR-A5AT03	—	—	—	—
		11K/15K	—	FR-AAT02	FR-AAT24	—	—	—
		18.5K/22K	—	—	FR-A5AT04	FR-A5AT04	—	—
		30K	—	—	—	FR-AAT27	○	—
		37K/45K	—	—	—	—	FR-AAT23	○
	55K	—	—	—	—	—	FR-A5AT05	
	FR-A540	0.4K to 3.7K	○	—	—	—	—	—
		5.5K/7.5K	FR-AAT22	○	—	—	—	—
		11K to 22K	—	FR-AAT02	FR-AAT24	○	—	—
		30K	—	—	—	FR-AAT27	○	—
	FR-A740	37K to 55K	—	—	—	—	FR-AAT23	○
		0.4K to 3.7K	○	—	—	—	—	—
		5.5K/7.5K	FR-AAT22	○	—	—	—	—
		11K/15K	—	FR-A5AT03	○	—	—	—
18.5K/22K		—	—	FR-AAT24	○	—	—	
30K	—	—	—	FR-AAT27	○	—		
37K to 55K	—	—	—	—	FR-AAT23	○		

○: Mountable without an intercompatibility attachment
FR-A5AT□□, FR-AAT□□: Easily replaceable with a stated intercompatibility attachment.

<<List of replacement with FR-F820>>

Model name and capacity of conventional model		FR-F820						
		0.75K/1.5K	2.2K to 5.5K	7.5K/11K	15K	18.5K to 30K	37K	45K/55K
Model name and capacity of conventional model	FR-A120E	0.75K	FR-A5AT01	—	—	—	—	—
		1.5K to 3.7K	FR-A5AT02	FR-A5AT02	—	—	—	—
		5.5K to 11K	—	FR-A5AT03	FR-A5AT03	—	—	—
		15K/18.5K	—	—	FR-AAT02	FR-AAT24	○	—
		22K/30K	—	—	—	FR-A5AT04	FR-A5AT04	—
		37K	—	—	—	—	FR-AAT27	○
		45K	—	—	—	—	—	FR-AAT23
	55K	—	—	—	—	—	—	FR-A5AT05
	FR-F520	0.75K	○	—	—	—	—	—
		1.5K to 3.7K	FR-AAT21	○	—	—	—	—
		5.5K/7.5K	—	FR-AAT22	○	—	—	—
		11K	—	FR-A5AT03	FR-A5AT03	—	—	—
		15K to 22K	—	—	FR-AAT02	FR-AAT24	○	—
		30K	—	—	—	FR-A5AT04	FR-A5AT04	—
		37K	—	—	—	—	FR-AAT27	○
	45K	—	—	—	—	—	FR-AAT23	
	55K	—	—	—	—	—	—	FR-A5AT05
	FR-F720(P)	0.75K/1.5K	○	—	—	—	—	—
		2.2K to 5.5K	FR-AAT21	○	—	—	—	—
		7.5K/11K	—	FR-AAT22	○	—	—	—
		15K	—	FR-A5AT03	FR-A5AT03	○	—	—
18.5K to 30K		—	—	—	FR-AAT24	○	—	
37K	—	—	—	—	FR-AAT27	○		
45K/55K	—	—	—	—	—	FR-AAT23		

○: Mountable without an intercompatibility attachment
FR-A5AT□□, FR-AAT□□: Easily replaceable with a stated intercompatibility attachment.

Structure option

<<List of replacement with FR-F840>>

		FR-F840						
		0.75K to 5.5K	7.5K/11K	15K/18.5K	22K/30K	37K	45K/55K	
Model name and capacity of conventional model	FR-A140E	0.75K to 3.7K	FR-A5AT02	—	—	—	—	—
		5.5K to 11K	FR-A5AT03	FR-A5AT03	—	—	—	—
		15K/18.5K	—	FR-AAT02	FR-AAT24	—	—	—
		22K	—	—	FR-A5AT04	FR-A5AT04	—	—
		30K	—	—	—	FR-AAT27	—	—
		37K/45K	—	—	—	—	FR-AAT23	○
	55K	—	—	—	—	—	FR-A5AT05	
	FR-F540	0.75K to 3.7K	○	—	—	—	—	—
		5.5K to 11K	FR-AAT22	○	—	—	—	—
		15K to 22K	—	FR-AAT02	FR-AAT24	○	—	—
		30K/37K	—	—	—	FR-AAT27	○	—
		45K/55K	—	—	—	—	FR-AAT23	○
	FR-F740(P)	0.75K to 5.5K	○	—	—	—	—	—
		7.5K/11K	—	○	—	—	—	—
		15K/18.5K	FR-A5AT03	FR-A5AT03	○	—	—	—
		22K/30K	—	—	FR-AAT24	○	—	—
		37K	—	—	—	FR-AAT27	○	—
	45K/55K	—	—	—	—	FR-AAT23	○	

○: Mountable without an intercompatibility attachment

FR-A5AT[[]], FR-AAT[[]]: Easily replaceable with a stated intercompatibility attachment.

<<FR-F8AT>>

The FR-F8AT01 can be used for replacing FR-F520L-75K and FR-F720-75K with FR-F820-03160(75K).

<<List of replacement with FR-E720>>

		FR-E720		
		0.1K to 0.75K	1.5K	2.2K/3.7K
Model name and capacity of conventional model	FR-A024	0.1K to 0.75K	FR-E7AT01	—
		1.5K	—	FR-E7AT02
		2.2K/3.7K	—	FR-E7AT03

<<List of replacement with FR-E740>>

		FR-E740	
		0.4K/0.75K	1.5K to 3.7K
Model name and capacity of conventional model	FR-A044	0.4K/0.75K	—
		1.5K to 3.7K	FR-E7AT03

FR-E7AT[[]]: Easily replaceable with a stated intercompatibility attachment.

DIN rail installation attachment

FR-UDA E700 F700PJ D700

Use of attachment enables the inverter to be installed on DIN rail.

●Selection

- Make selection according to the applicable inverter or energy saving drive capacity in the table.

Inverter		Applicable Inverter Capacity		
		FR-UDA01	FR-UDA02	FR-UDA03
FR-E700	Single phase 100V class	FR-E710W-0.1K to 0.4K	FR-E710W-0.75K	—
	Single phase 200V class	FR-E720S-0.1K to 0.4K	FR-E720S-0.75K, 1.5K	—
	200V class	FR-E720-0.1K to 0.75K	FR-E720-1.5K, 2.2K	FR-E720-3.7K
FR-F700PJ	200V class	FR-F720PJ-0.4K, 0.75K	FR-F720PJ-1.5K, 2.2K	FR-F720PJ-3.7K
	400V class	—	FR-F740PJ-0.4K to 3.7K	—
FR-D700	Single phase 100V class	FR-D710W-0.1K to 0.4K	FR-D710W-0.75K	—
	Single phase 200V class	FR-D720S-0.1K to 0.75K	FR-D720S-1.5K	—
	200V class	FR-D720-0.1K to 0.75K	FR-D720-1.5K, 2.2K	FR-D720-3.7K
	400V class	—	FR-D740-0.4K to 3.7K	—

●Approximate dimension

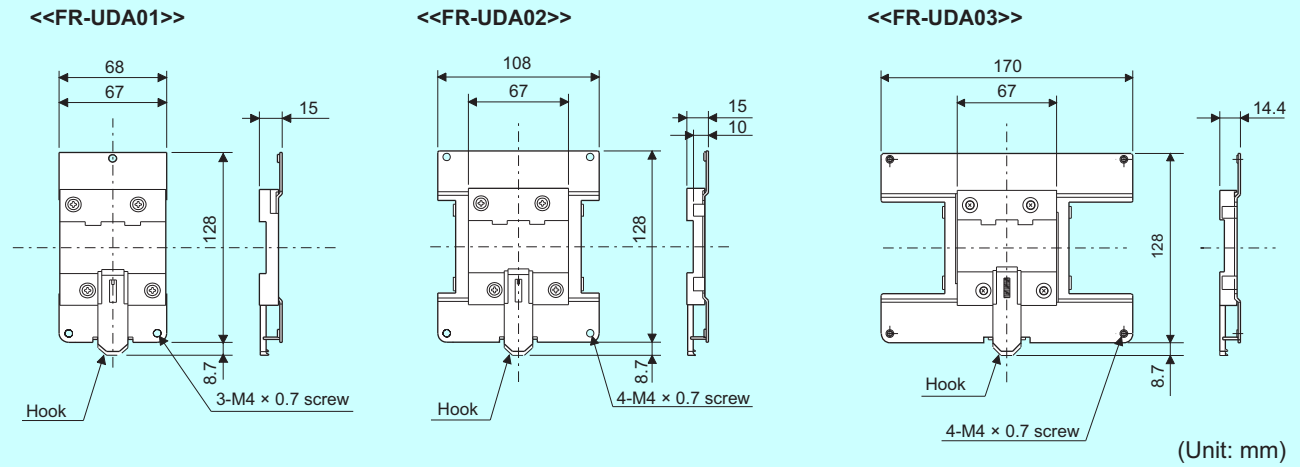

FR series manual controller/speed controller

Preamplifier

FR-FA ALL

Preamplifier is used to convert and amplify the controller current signal to voltage signal when making the controller output applicable as frequency setting signal to the inverter.

●Connection diagram (Sink logic)

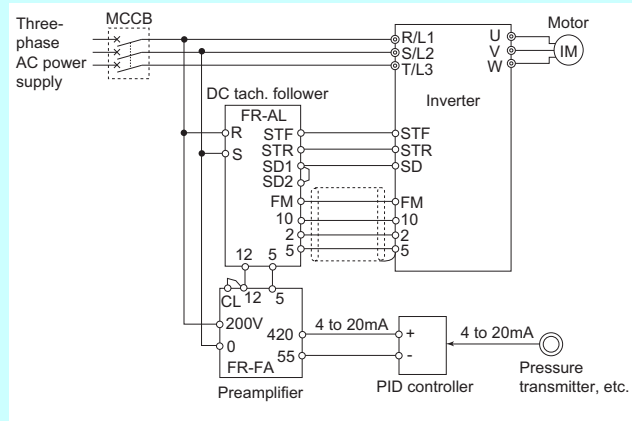

●Outline dimension drawings

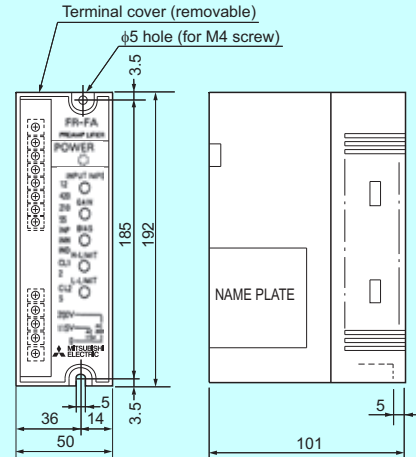

Soft starter

FR-FC ALL

Soft starter is used with the inverter to gradually increase or decrease the frequency setting signal level at starting and stopping the inverter, or changing frequency, in order to eliminate a shock that otherwise will be given to the machine, or to synchronize starting or stopping of two or more motors to accelerate and decelerate in accordance with the largest load inertia, etc. Although the inverter has soft start/stop function as standard, use this device to batch-coordinate all inverters, etc.

●Connection diagram (Sink logic)

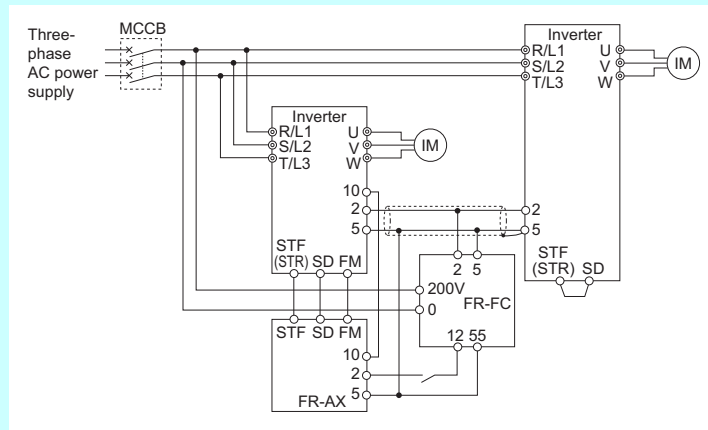

●Outline dimension drawings

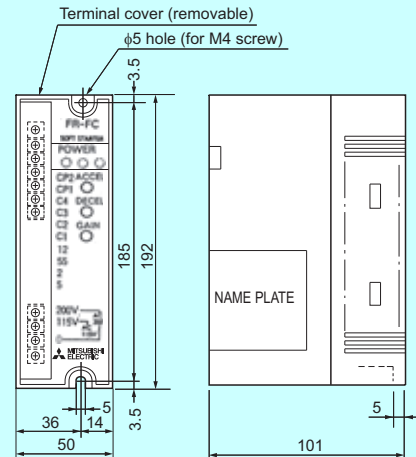

Deviation detector

FR-FD **ALL**

The deviation detector is a converter that changes angular displacement, detected by synchronizer, to a DC voltage signal. Beside mechanical displacement, the synchronizer is capable of detecting tension, weight and angular difference between two rotating shafts. Therefore, it can be used in a control system with the inverter.

●Connection diagram (Sink logic)

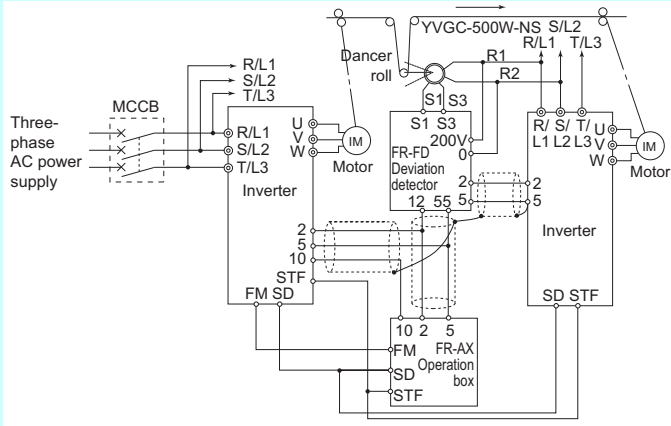

●Outline dimension drawings

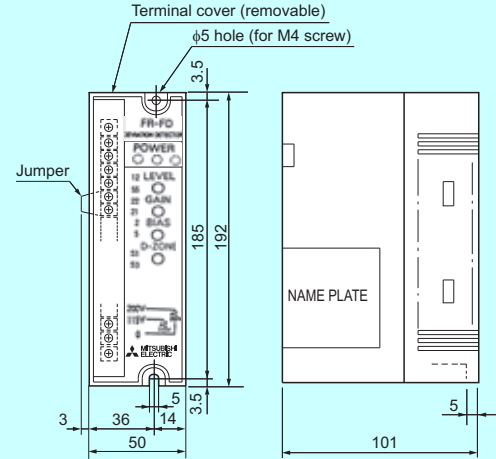

Master controller

FR-FG **ALL**

Master controller is a variable-voltage power supply unit, and used to deliver frequency setting signal to the inverters (up to 35 inverters), or to control a maximum of 175 inverters with ratio setter "FR-FH" in proportional speed control operation.

●Connection diagram (Sink logic)

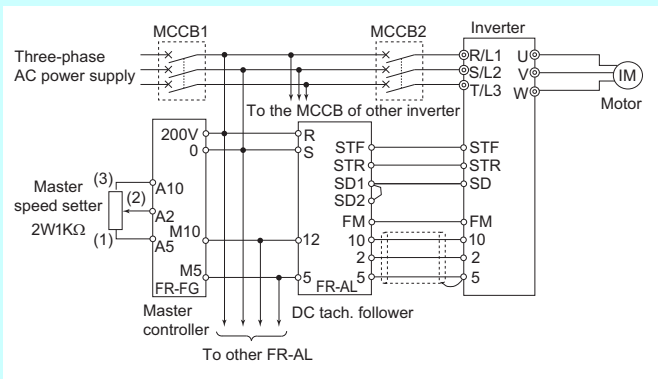

●Outline dimension drawings

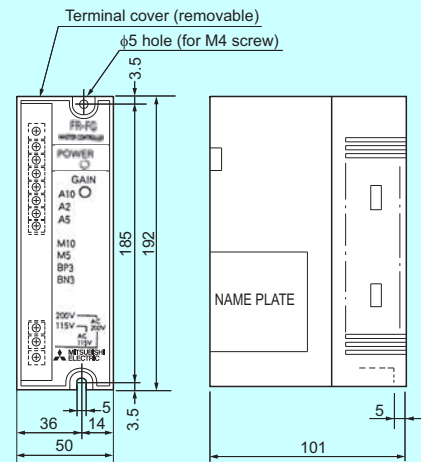

Ratio setter

FR-FH ALL

This device has five ratio setting circuit consists of operational amplifier and performs ratio operation of five inverters.

●Connection diagram (Sink logic)

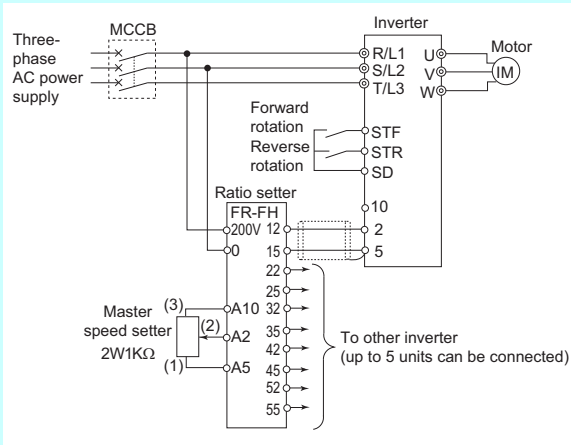

●Outline dimension drawings

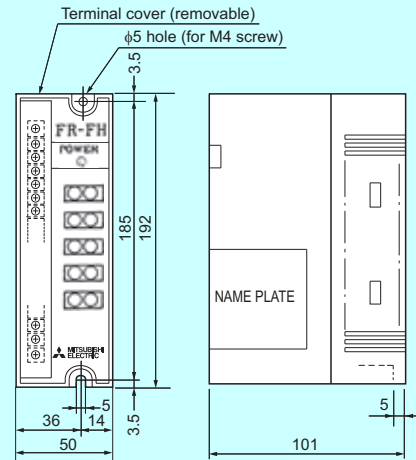

Remote speed setter

FR-FK ALL

Use this device to start and stop the motor, change speed, etc. from several remote locations. Note that the frequency setting values are stored even if the power is shut off, the inverter operates at the previous frequency at power restoration.

●Connection diagram (Sink logic)

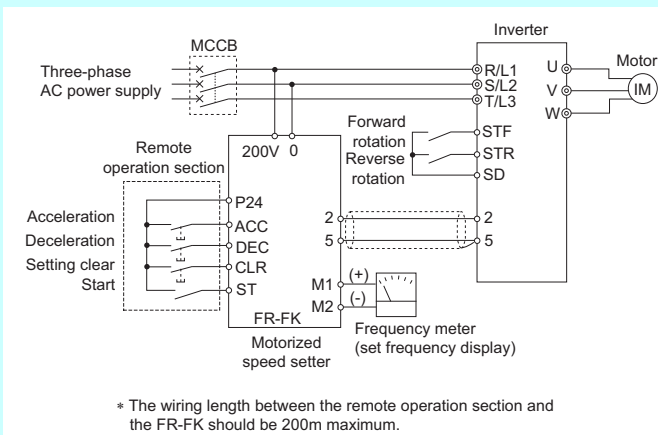

●Outline dimension drawings

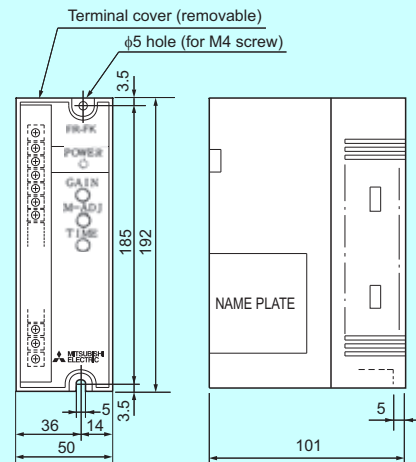

Speed detector

FR-FP **ALL**

Speed, mechanical displacement etc. of other equipment is converted into an electrical signal using a PG (pulse generator) and the signal is then entered into the FR-FP speed detector which converts it into the frequency setting signal of the inverter.

●Connection diagram (Sink logic)

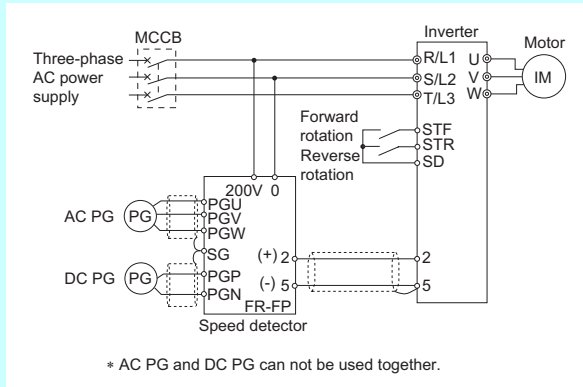

●Outline dimension drawings

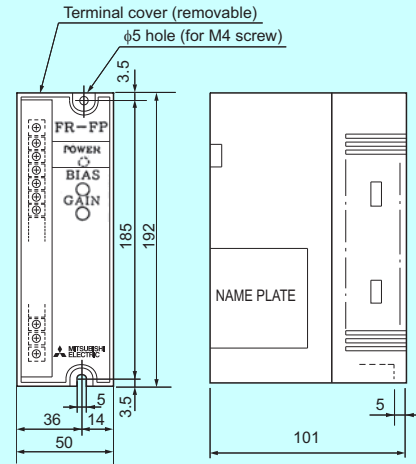

DC tach. follower

FR-AL **ALL**

Setting the select switch in "AUTO" position makes the frequency setting output to the inverter follow the voltage signal from other equipment and "MANUAL" position allows independent manual operation with the knob provided on the controller. This can be used as auto/manual switching controller.

●Connection diagram (Sink logic)

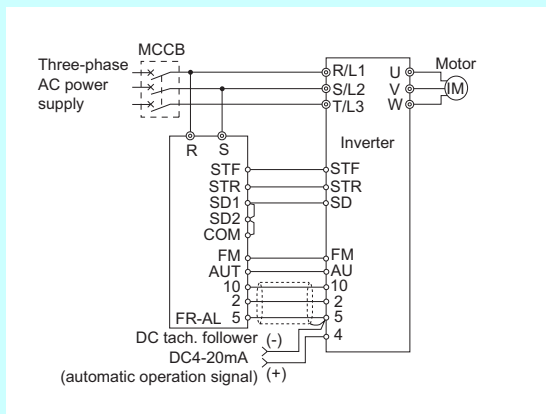

●Outline dimension drawings

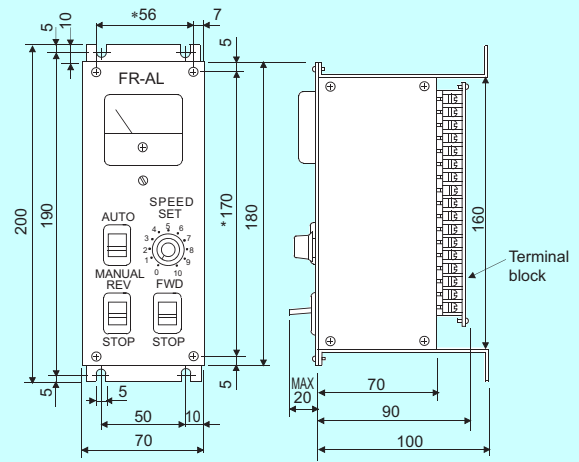

* Mounting dimensions when embedding in an enclosure, etc.

Three speed selector

FR-AT **ALL**

The "FR-AT" speed selector can be used with the FR series inverters to start/stop a motor and also allows you to perform operation at three different preset frequencies using the setting select switch, frequency selecting limit switch etc.

●Connection diagram (Sink logic)

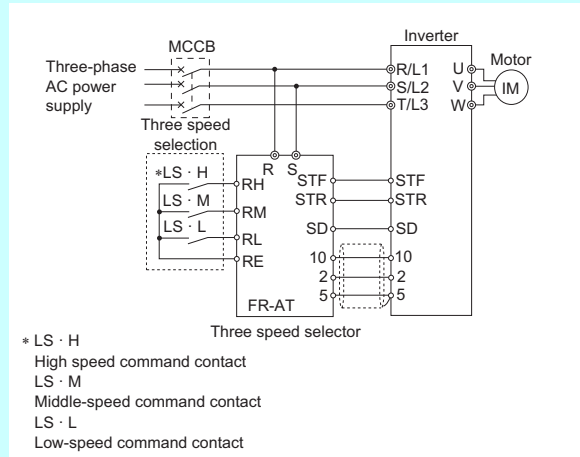

●Outline dimension drawings

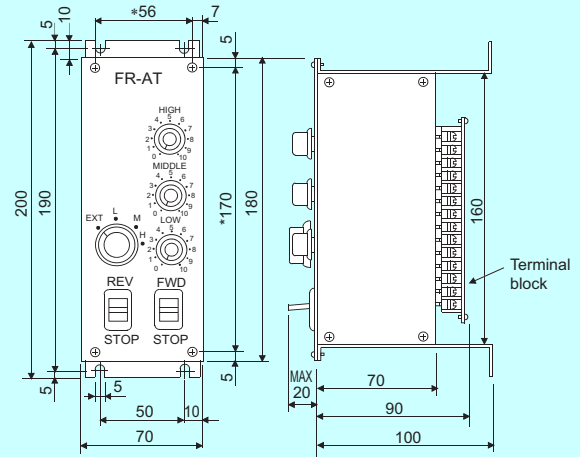

* Mounting dimensions when embedding in an enclosure, etc.

Manual controller

FR-AX **ALL**

Equipped with the frequency setting potentiometer, frequency meter and start/stop switches, the "FR-AX" manual controller can be used in the most general applications where independent operation is performed manually.

●Connection diagram (Sink logic)

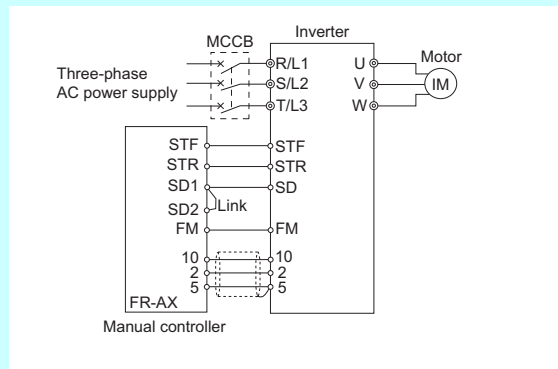

●Outline dimension drawings

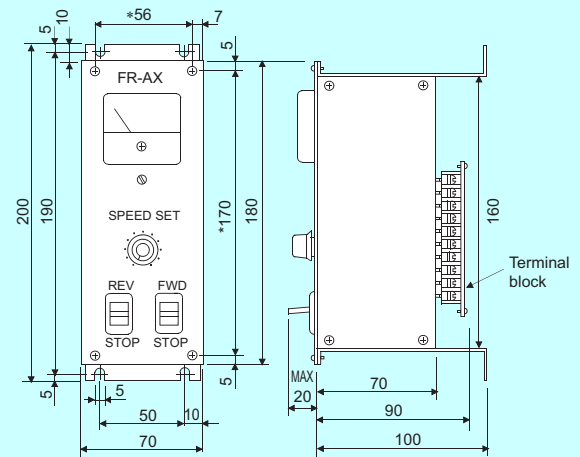

* Mounting dimensions when embedding in an enclosure, etc.

Other options

Pilot generator

QVAH-10 ALL

In combination with the speed detector FR-FP, tracking operation, etc. of the base motor and sub-motor can be performed.

●Specifications

Item	Description
Output voltage	70V/35VAC at 2500r/min
Output	10W/5W *1
Linearity	1% or less
Maximum speed	5000r/min *2
Number of poles	Single phase 24 poles
Rotation torque	At starting 0.14N·m During running 0.05N·m

- *1 When outputting 10W between terminal U-V, output 1W or less between terminal U-0 (or 0-V).
- *2 Operating at 2500r/min or more degrades linearity.

●Outline dimension drawings

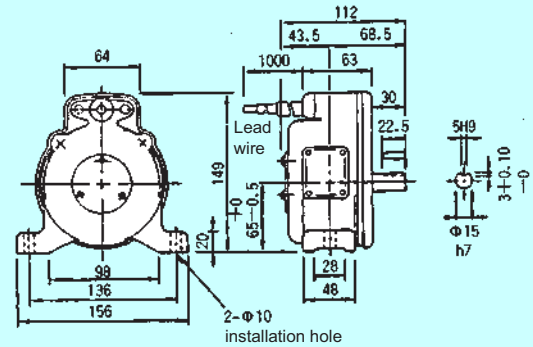

Deviation sensor

YVGC-500W-NS ALL

This detector detects the angular displacement of motor shaft and output as AC voltage. It has a built-in limit switch for both end detection.

●Specifications

Item	Description
Power supply voltage	200V/220VAC 50Hz/60Hz
Contact capacity	250VAC 6A
Used angular displacement *1	±60°
Maximum angular displacement *2	±140° ±10°
Maximum output voltage	At 200VAC input ... 82VAC/90° At 200VAC input ... 90VAC/90°
Rotation torque	0.02N·m or less

- *1 Used angular displacement indicates the rotation angle until the limit switch operates.
- *2 Maximum displacement angle indicates the maximum rotation angle of the machine (to the stopper) of the deviation sensor.

●Outline dimension drawings

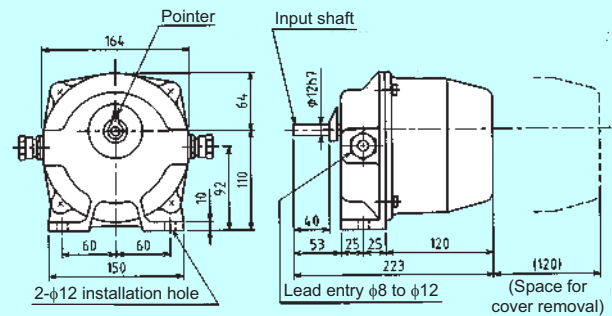

Digital frequency meter

HZ-1N (introduced product) ALL

Connect the frequency meter between terminal FM-SD of the inverter to indicate the inverter output frequency by FM output (pulse).
Introduced product: HZ-1N *

* Please contact your sales representative or the nearest Mitsubishi FA Center.



HZ-1N (introduced product)

●Specifications

Item	Description
Display digit	3 digits
Minimum resolution	1Hz
Sampling period	Approx. 166ms
Frequency display switching	0 to 60Hz, 0 to 120Hz, 0 to 240Hz switching function
Power supply voltage	100/200VAC ±10% 50/60Hz

●Outline dimension drawings

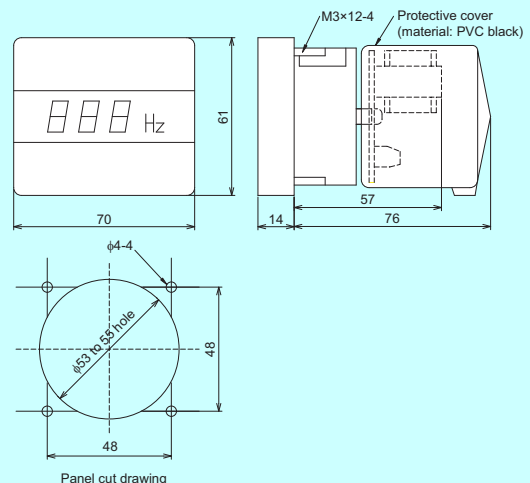

Analog frequency meter

YM206NRI 1mA **ALL**

KY-452 (introduced product) **ALL**

Connect a full-scale 1mA ammeter to the inverter terminal FM-SD to display the inverter output frequency.

Introduced product: KY-452 *

* Please contact your sales representative or the nearest Mitsubishi FA center.

●Specifications

<<YM206NRI 1mA>>

Item	Description
Principle of operation	Moving-coil type
Scale specifications	0 to 65Hz, 130Hz double scale

<<KY-452 (introduced product)>>

Item	Description
Principle of operation	Moving-coil type
Scale specifications	0 to 60Hz, 120Hz double scale



YM206NRI 1mA



KY-452 (introduced product)

●Outline dimension drawings

<<YM206NRI 1mA>>

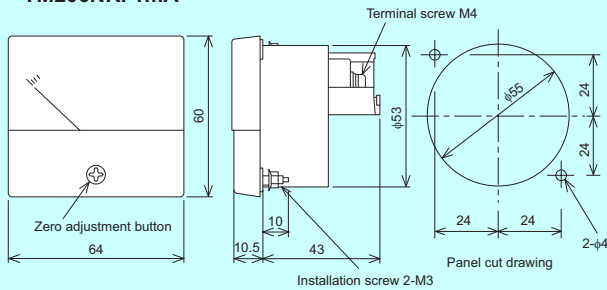

<<KY-452 (introduced product)>>

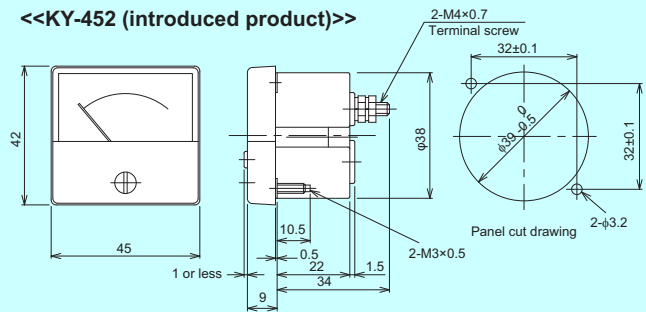

Calibration resistor

RV24YN 10k Ω **ALL**

Calibrate analog frequency meter with this variable resistor. Connect this resistor between the inverter and frequency meter to change the value of current flow. (It is not necessary when calibrating the meter from the operation panel/parameter unit.)

●Specifications

Item	Description
Characteristic	Carbon film variable resistor 1/3W 10k Ω B characteristic
Shaft rotation angle	300° \pm 5°

●Outline dimension drawings

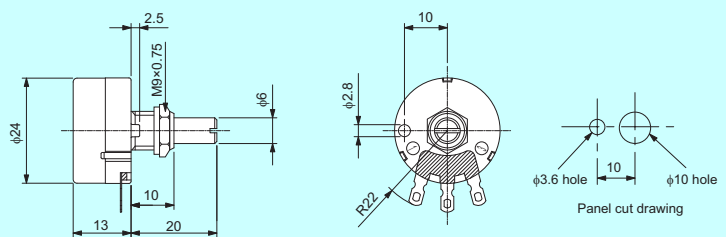

**Frequency setting potentiometer
Pointer scale
Knob**

- WA2W 1kΩ (ALL)
- MEM-40 (introduced product) (ALL)
- K-3 (introduced product) (ALL)
- WA-2W40SET-S (introduced product) (ALL)

Connect the variable resistor between terminal 10-2-5 of the inverter to set the inverter running frequency.

Introduced product: MEM-40, K-3, WA-2W40SET-S *

* Please contact your sales representative or the nearest Mitsubishi FA center.

●Specifications

Item	Description
Characteristic	Wire wound variable resistor 2W 1kΩ B characteristic
Shaft rotation angle	300° ±5°

●Outline dimension drawings

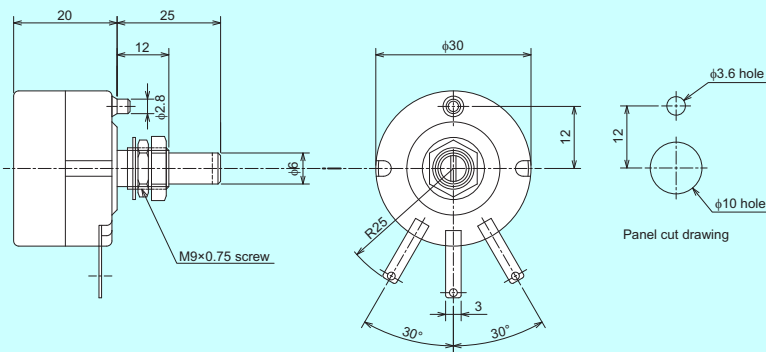

WA2W 1kΩ



**MEM-40
(introduced product)**



**K-3
(introduced product)**

WA-2W40SET-S includes
WA2W, MEM-40, and K-3.

MEMO

MEMO

We visualize our customers' factories to solve problems and troubles.

"Visualization" of production and energy achieves future factories that advance one step forward.

The integrated solution, e-F@ctory, is based on our consolidated know-how, which has been developed through our own experiences as a user of FA products. Our e-F@ctory provides total cost reduction ranging from development to production and maintenance to achieve optimized production. This solution makes it possible to save energy and to optimize production by "visualization" that links upstream information systems and production site information, thus solving various problems on production sites.

Sharing information across production systems

MES Interface

Information sharing is easy and inexpensive because communication gateways, such as personal computers, are not necessary to connect factory equipment to the Manufacturing Execution System (MES).

Optimizing production from a TCO* stand point

iQ Platform

Factory automation components such as controllers, human-machine interfaces, engineering environments, and networks are all seamlessly integrated to reduce TCO across different stages, from development to production and maintenance.

* TCO: Total Cost of Ownership



Visualization of energy consumption

e&eco-F@ctory

It is indispensable for today's factory to be energy conscious and efficient. The e-F@ctory solution enables management of specific energy consumption, which provides the visibility needed to improve productivity. Additionally, this solution takes the total life cycle into account, including factors such as "measurement and diagnosis", "countermeasures", and "operation and management". Backed by several successes and achievements, our know-how will support your energy saving efforts.



Network

CC-Link Family, the open field network of the world standard, and SSCNET III/H, the servo network for achieving high-speed processing and enhancement of instruction synchronization, flexibly expanding the connectivity among equipment and devices in the e-F@ctory environment.

iQ Platform-compatible equipment

The inter-multi-CPU high-speed base unit provides slots for arbitrarily connecting programmable controllers, motion controllers, on-line CNCs, and robot controllers. Data communication speed among devices is enhanced, and their compatibility is extremely improved.

iQ Platform-compatible engineering environments

Design information is integrated and shared at stages from system design to programming, tests and startup, and operation and maintenance. In addition, programming software programs for programmable controllers, motion controllers, on-line CNCs, robots, inverters, and GOTs, which are separately provided in a conventional environment, can be integrated.



e-Factory

Products for achieving e-F@ctory

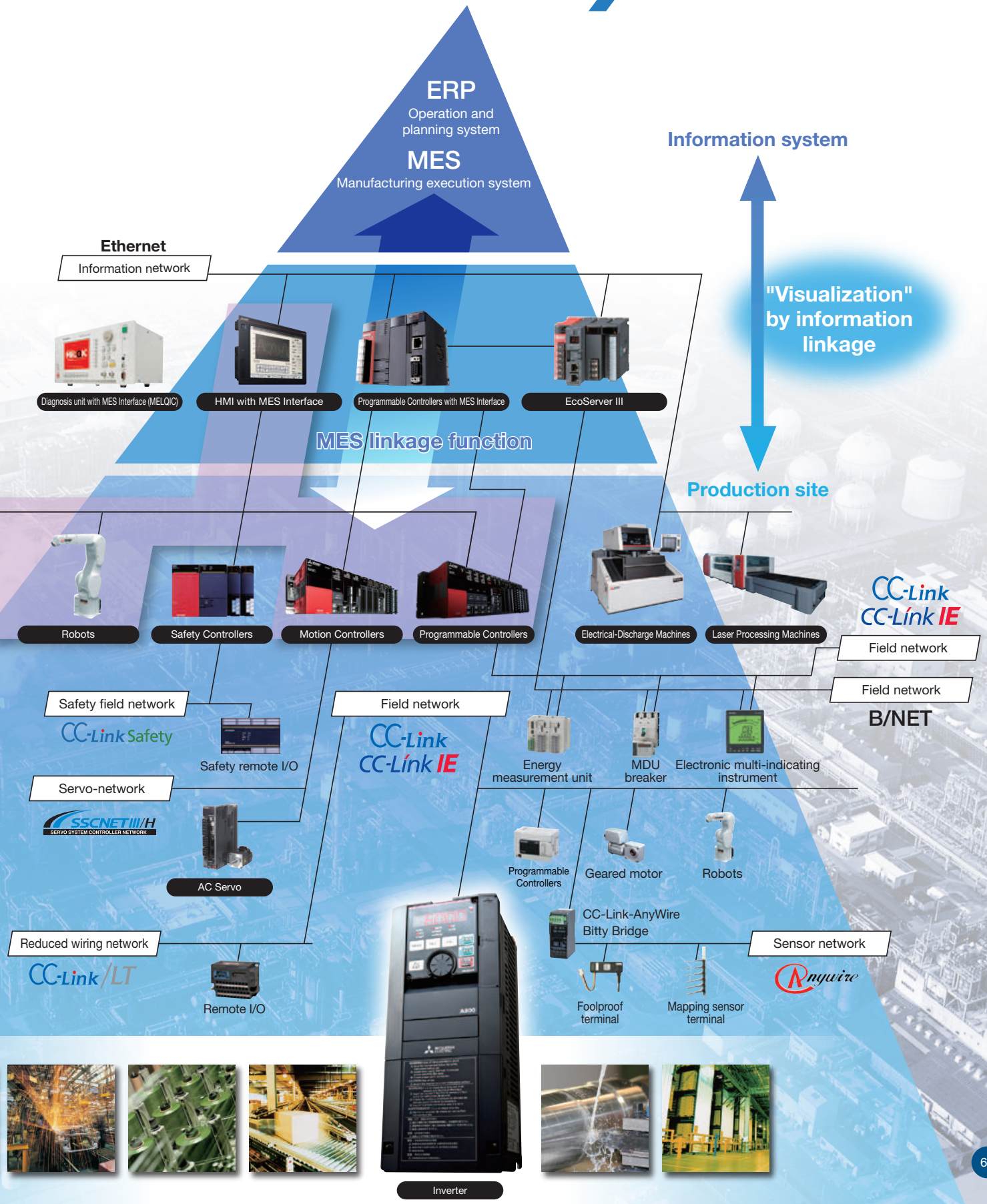

Global network for comprehensive support of

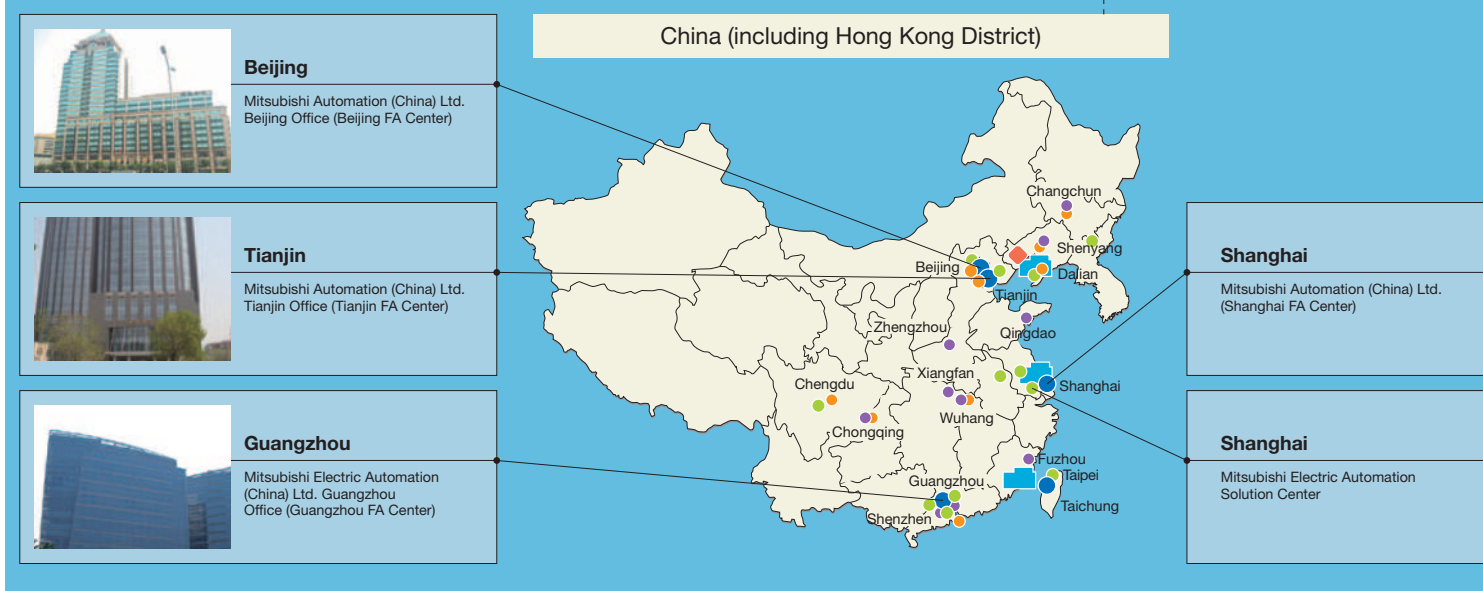
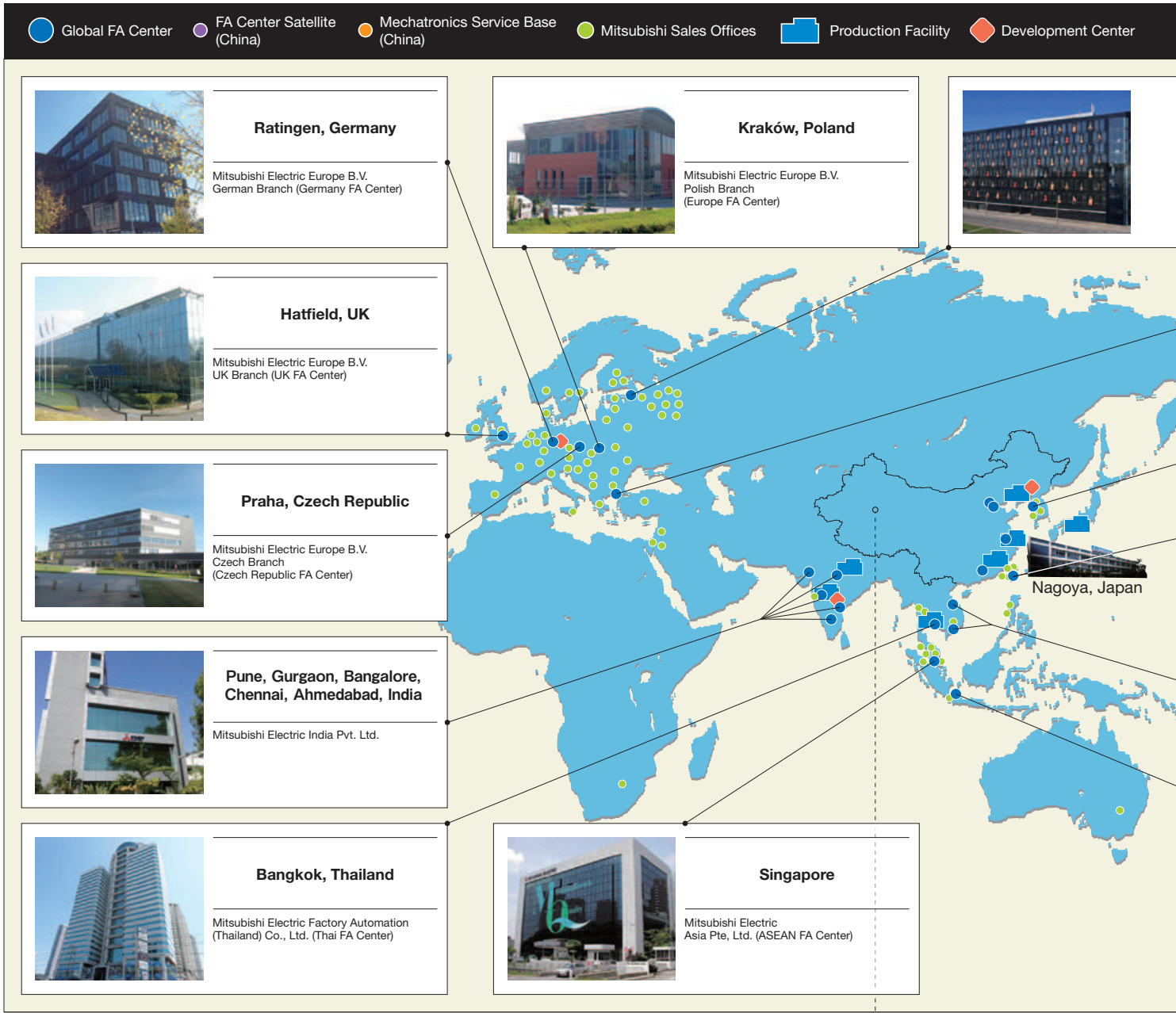

customers' manufacturing.



Service bases are established around the world to globally provide the same services as in Japan.

Overseas bases are opened one after another to support business expansion of our customers.

Overseas bases | As of July 2014 * Some includes distributors

Area	Our overseas offices		Bases providing our products	Countries (Regions)
		FA Center (Satellite)		
EMEA	11	6 (2)	146	54
China	13	4 (10)	171	1
Asia	21	13	79	10
America	14	4 (0)	130	16
Others	1	0	3	2
Total	60	27 (12)	529	83

MEMO

•Trademarks

LONWORKS is a registered trademark of Echelon Corporation, DeviceNet is a trademark of the ODVA, PROFIBUS is a trademark of the PROFIBUS User Organization, and MODBUS is a registered trademark of SCHNEIDER ELECTRIC USA, INC.

Ethernet is a registered trademark of Fuji Xerox Corporation in Japan.

Windows is a registered trademark of Microsoft Corporation in the United States and other countries.

Other company and product names herein are the trademarks and registered trademarks of their respective owners.

Safety Warning

To ensure proper use of the products listed in this catalog, please be sure to read the instruction manual prior to use.

YOUR SOLUTION PARTNER

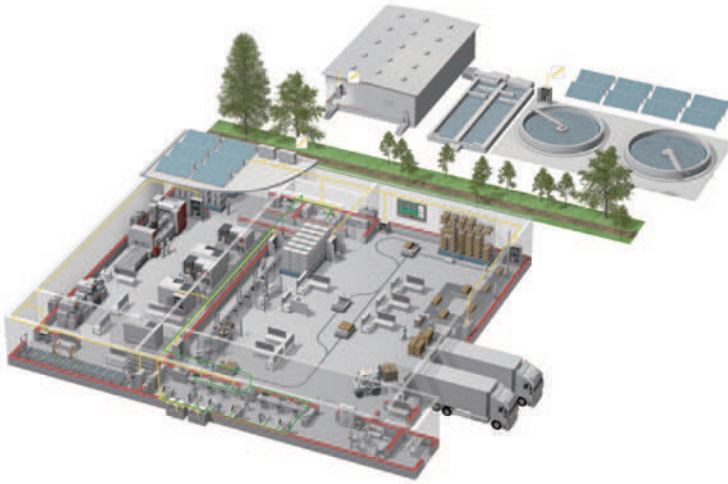

Mitsubishi Electric offers a wide range of automation equipment from PLCs and HMIs to CNC and EDM machines.

A NAME TO TRUST

Since its beginnings in 1870, some 45 companies use the Mitsubishi name, covering a spectrum of finance, commerce and industry.

The Mitsubishi brand name is recognized around the world as a symbol of premium quality.

Mitsubishi Electric Corporation is active in space development, transportation, semi-conductors, energy systems, communications and information processing, audio visual equipment and home electronics, building and energy management and automation systems, and has 237 factories and laboratories worldwide in over 121 countries.

This is why you can rely on Mitsubishi Electric automation solution - because we know first hand about the need for reliable, efficient, easy-to-use automation and control in our own factories.

As one of the world's leading companies with a global turnover of over 4 trillion Yen (over \$40 billion), employing over 100,000 people, Mitsubishi Electric has the resource and the commitment to deliver the ultimate in service and support as well as the best products.



Low-voltage Circuit Breakers, Motor Starters



High-voltage Circuit Breakers, High-voltage Contactors



Energy Saving Supporting Devices, Power Monitoring Products



Programmable Controllers, HMIs (Human-Machine Interfaces)



AC Servos, Three-phase Motors, IPM Motors
Inverters, Geared Motors



Computerized Numerical Controllers (CNCs)



Industrial Robots

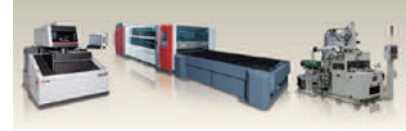

Electrical Discharge Machines, Laser Processing Machines,
Electron Beam Machines



Distribution Transformers



Pressurized Ventilation Fans, Uninterruptible Power Supplies

* All products are not available in all countries.

Mitsubishi Electric Corporation Nagoya Works is a factory certified for ISO14001 (standards for environmental management systems) and ISO9001 (standards for quality assurance management systems)

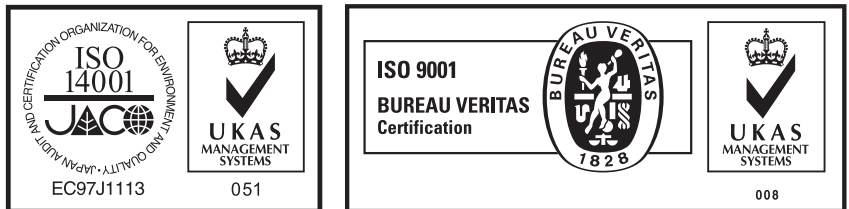

MITSUBISHI ELECTRIC CORPORATION

HEAD OFFICE: TOKYO BLDG., 2-7-3, MARUNOUCHI, CHIYODA-KU, TOKYO 100-8310, JAPAN