

ProcessMaster FEP630, FEW630

HygienicMaster FEH630

Electromagnetic flowmeter



Safety instructions ATEX / IECEx
Zone 1, 2, 21, 22.

Measurement made easy

—
FEP630
FEW630
FEH630
FET630

Introduction

This document forms an integral part of the following manuals:

- Operating instruction
OI/FEP630/FEW630/FEH630
- Commissioning instruction
CI/FEP630/FEW630/FEH630

Additional Information

Additional documentation on ProcessMaster FEP630, FEW630, HygienicMaster FEH630 is available for download free of charge at www.abb.com/flow. Alternatively simply scan this code:



Table of contents

1	Safety	4	5	Digital communication	21
	General information and instructions	4		Standard Ethernet communication	21
	Warnings	4		Standard Ethernet 10/100 BASE-T/TX (IEEE802.3)	21
	Intended use.....	4		Ethernet connection to remote or integral design	
	Improper use	4		transmitter.....	21
	Cyber security disclaimer.....	5		M12 connector (optional)	22
	Software downloads.....	5		RJ45 connector (optional).....	23
	Warranty provisions.....	5		Ground the Ethernet connection cable	24
	Manufacturer's address	5		Ethernet APL™ communication.....	25
	Service address	5		Ethernet-APL™ 10BASE-T1L (IEEE 802.3cg).....	25
				Ethernet-APL™ connection to remote or integral	
				design transmitter.....	25
				Electrical Data.....	25
2	Device designs	6	6	Installing the plug-in cards	26
	Overview – Electrical connections.....	7		Optional plug-in cards.....	26
	Devices in integral mount design.....	7			
	ATEX / IECEx Zone 1 – Devices with HART®,				
	Modbus®, Profibus®, any analog Plug-in Card.....	8			
	ATEX / IECEx Zone 1 – Devices with Ethernet-APL™				
	(Ordercode DR7).....	9			
	ATEX / IECEx Zone 2 – Devices with HART®,				
	Modbus®, Profibus®, any analog Plug-in Card.....	10			
	ATEX / IECEx Zone 2 – Devices with standard				
	Ethernet plug-in card (Ordercode DR6).....	10			
	ATEX / IECEx Zone 2 – Devices with Ethernet-APL™				
	(Ordercode DR7).....	11			
	Devices in remote mount design.....	12			
	ATEX / IECEx Zone 1 – Flowmeter sensor	12			
	ATEX / IECEx Zone 2 – Flowmeter sensor	13			
	ATEX / IECEx Zone 1, 2 – Transmitter.....	14			
3	Product identification	16	7	Operation in Zone 1, 21	27
	Name plate	16		Electrical connections	27
	Marking in accordance with Pressure Equipment			Single compartment housing (integral and remote	
	Directive 2014/68/EU	16		version).....	27
	Devices according to ATEX (CE).....	16		Dual compartment housing (remote version).....	27
				Electric data for operation in Zone 1, 21.....	29
				Special conditions	31
				Zone 1/12 – Certificate No. FM17ATEX0016X and	
				FM21UKEX0033X	31
				Special connection conditions.....	31
				Protection against electrostatic discharges.....	32
				Repair	32
				Temperature data.....	33
				Surface temperature.....	33
				Measuring medium temperature as a function of liner	
				and flange material.....	33
				Measuring medium temperature (Ex Data) for	
				ProcessMaster Model FEP631.....	34
				Measuring medium temperature (Ex Data) for	
				ProcessMaster Model FEP632.....	35
				Measuring medium temperature (Ex Data) for	
				ProcessMaster Model FEW631.....	36
				Measuring medium temperature (Ex Data) for	
				ProcessMaster Model FEW632.....	37
				Measuring medium temperature (Ex Data) for	
				HygienicMaster Model FEH631	38
				Measuring medium temperature (Ex Data) for	
				HygienicMaster Model FEH632.....	39
4	Housing	17			
	Opening and closing the housing.....	17			
	Dual- compartment housing	17			
	Single-compartment housing	18			
	Rotating the transmitter housing and LCD display....	18			
	Installation instructions	19			
	ATEX / IECEx.....	19			
	Use in areas exposed to combustible dust.....	19			
	Electrical connections	20			
	Temperature resistance for the connecting cable....	20			
	Grounding	20			
	High temperature design.....	20			

8 Operation in Zone 2, 22	40	11 Repair	54
Electrical connections	40	Safety instructions	54
Single compartment housing (integral and remote version).....	40	Spare parts.....	54
Dual compartment housing (remote version).....	40	Replacing the fuse	54
Electrical data for operation in Zone 2, 22.....	42	Replacing the LCD indicator	55
Special conditions.....	43	Replacing the frontend board	56
Zone 2/22 – Certificate No. FM17ATEX0017X and FM21UKEX0032X	43	Integral mount design	56
Special connection conditions.....	43	Remote mount design	58
Protection against electrostatic discharges.....	43	Replacing the motherboard.....	59
Temperature data.....	44	Replacing the sensor	60
Surface temperature.....	44	Returning devices	60
Measuring medium temperature as a function of liner and flange material.....	44	Address for returns.....	60
Measuring medium temperature (Ex Data) for ProcessMaster Model FEP631	45	12 Recycling and disposal	61
Measuring medium temperature (Ex Data) for ProcessMaster Model FEP632.....	46	Dismounting.....	61
Measuring medium temperature (Ex Data) for ProcessMaster Model FEW631	47	Disposal.....	61
Measuring medium temperature (Ex Data) for ProcessMaster FEW632	48	13 Additional documents	61
Measuring medium temperature (Ex Data) for HygienicMaster Model FEH631	49	14 Appendix	62
9 Commissioning	51	Return form.....	62
Checks before commissioning	51	Installation diagram 3KXF000061G0009.....	63
Output configuration for NAMUR switching amplifier ...	51		
Configuring the current output	51		
Configuring the digital outputs.....	51		
10 Maintenance	53		
Safety instructions	53		
Sensor	53		
Gaskets.....	53		
Cleaning.....	53		

1 Safety

General information and instructions

These instructions are an important part of the product and must be retained for future reference.

Installation, commissioning, and maintenance of the product may only be performed by trained specialist personnel who have been authorized by the plant operator accordingly. The specialist personnel must have read and understood the manual and must comply with its instructions.

For additional information or if specific problems occur that are not discussed in these instructions, contact the manufacturer.

The content of these instructions is neither part of nor an amendment to any previous or existing agreement, promise or legal relationship.

Modifications and repairs to the product may only be performed if expressly permitted by these instructions.

Information and symbols on the product must be observed.

These may not be removed and must be fully legible at all times.

The operating company must strictly observe the applicable national regulations relating to the installation, function testing, repair and maintenance of electrical products.

Warnings

The warnings in these instructions are structured as follows:

DANGER

The signal word '**DANGER**' indicates an imminent danger. Failure to observe this information will result in death or severe injury.

WARNING

The signal word '**WARNING**' indicates an imminent danger. Failure to observe this information may result in death or severe injury.

CAUTION

The signal word '**CAUTION**' indicates an imminent danger. Failure to observe this information may result in minor or moderate injury.

NOTICE

The signal word '**NOTICE**' indicates possible material damage.

Note

'**Note**' indicates useful or important information about the product.

Intended use

The device has been designed for use exclusively within the technical limit values indicated on the identification plate and in the data sheets.

When using measuring media, the following points must be observed:

- Wetted parts such as measuring electrodes, liner, grounding electrodes, grounding plates or protection plates must not be damaged by the chemical and physical properties of the measuring medium during the operating time.
- Measuring media with unknown properties or abrasive measuring media may only be used if the operator is able to perform regular and suitable tests to ensure the safe condition of the device
- The indications on the name plate must be observed
- Before use of corrosive or abrasive measuring media, the operator must clarify the level of resistance of wetted parts.
ABB will gladly support you in the selection, but cannot accept any liability in doing so.

Improper use

The following are considered to be instances of especially improper use of the device:

- Operation as a flexible compensating adapter in piping, for example for compensating pipe offsets, pipe vibrations, pipe expansions, etc.
- For use as a climbing aid, for example for mounting purposes.
- For use as a bracket for external loads, for example as a support for piping, etc.
- Material application, for example by painting over the housing, name plate or welding/soldering on parts.
- Material removal, for example by spot drilling the housing.

Cyber security disclaimer

This product is designed to be connected to and to communicate information and data via a network interface. It is operator's sole responsibility to provide and continuously ensure a secure connection between the product and your network or any other network (as the case may be). Operator shall establish and maintain any appropriate measures (such as but not limited to the installation of firewalls, application of authentication measures, encryption of data, installation of anti-virus programs, etc.) to protect the product, the network, its system and the interface against any kind of security breaches, unauthorized access, interference, intrusion, leakage and/or theft of data or information. ABB and its affiliates are not liable for damages and/or losses related to such security breaches, any unauthorized access, interference, intrusion, leakage and/or theft of data or information.

On www.abb.com/cybersecurity under 'Additional resources', 'Alerts and notifications' you will find notifications about newly discovered software vulnerabilities. It is recommended that you visit this website regularly and activate 'Subscribe to email alerts' to receive email notifications about 'ABB cyber security alerts and notifications'.

Software downloads

By visiting the web page indicated below, you will find options to download the latest software. It is recommended that you visit this web page regularly:

[ABB Library – FEP630 / FEW630 / FEH630](#)



Warranty provisions

Using the device in a manner that does not fall within the scope of its intended use, disregarding this manual, using underqualified personnel, or making unauthorized alterations releases the manufacturer from liability for any resulting damage. This renders the manufacturer's warranty null and void.

Manufacturer's address

ABB Limited
Measurement & Analytics
Oldends Lane, Stonehouse
Gloucestershire, GL10 3TA
UK
Tel: +44 (0)1453 826661
Fax: +44 (0)1453 829671
Email: instrumentation@gb.abb.com

ABB Inc.
Measurement & Analytics
7051 Industrial Boulevard
Bartlesville, OK 74006
USA
Tel: +1 918 338 4888
Fax: +1 918 338 4699

ABB Engineering (Shanghai) Ltd.
Measurement & Analytics
No. 4528, Kangxin Highway, Pudong New District
Shanghai, 201319,
P.R. China
Tel: +86(0) 21 6105 6666
Fax: +86(0) 21 6105 6677
Email: china.instrumentation@cn.abb.com

ABB Limited
Measurement & Analytics
Peenya Industrial Area
Bangalore-560058
India
Tel: 1800 420 0707 – Toll free
Tel: +91 80 67143000 – International
Email: contact.center@in.abb.com

Service address

To find your local ABB contact visit:
www.abb.com/contacts

For more information visit:
www.abb.com/measurement

2 Device designs

Two device ranges are available in the 630 series. ProcessMaster 630 and HygienicMaster 630. Two designs (integral mount / remote mount) are available within each device range.

This results in the following variants:

- ProcessMaster FEP631, FEW631, integral mount device
- ProcessMaster FEP632, FEW632, flow sensor remote mount design
- HygienicMaster FEH631, integral mount device
- HygienicMaster FEH632, flow sensor remote mount design
- Remote transmitter FET632 for ProcessMaster / HygienicMaster

Devices suitable for use in potentially explosive atmospheres feature the corresponding Ex mark on their name plates. Moreover, each device design has a specific model number.

The parts of the model number relating to explosion protection are listed in the following table. The complete key to model numbers is described in the device data sheet.

ProcessMaster FEP631, integral mount device	FEP631	XX	XX
ProcessMaster FEP632, flow sensor remote mount design	FEP632		
ProcessMaster FEW631, integral mount device	FEW631		
ProcessMaster FEW632, flow sensor remote mount design	FEW632		
HygienicMaster FEH631, integral mount device	FEH631		
HygienicMaster FEH632, flow sensor remote mount design	FEH632		
Remote transmitter for ProcessMaster / HygienicMaster	FET632		
Explosion protection			
Without			Y0
ATEX / IECEx (Zone 1 / 21)			A1
ATEX / IECEx (Zone 2 / 22)			A2
cFMus Class I, II, III Div. 1 (Zone 1 / 21)			F1
cFMus Class I, II, III Div. 2 (Zone 2 / 22)			F2
NEPSI (Zone 1 / 21)			S1
NEPSI (Zone 2 / 22)			S2
Design / terminal box material / cable glands			
Single-compartment / aluminum / M20 x 1.5			S1
Single-compartment / Aluminum / NPT ½ in			S2
Dual-compartment / aluminum / M20 x 1.5			D1
Dual-compartment / aluminum / NPT ½ in.			D2
Remote mount / aluminum / M20 x 1.5			A1
Remote mount / Aluminum / NPT ½ in			A2
Field mount housing / single-compartment / aluminum / M20 x 1.5			F1
Field mount housing / single-compartment / aluminum / NPT ½ in			F2
Wall-mount housing / dual-compartment / aluminum / M20 x 1.5			W1
Wall-mount housing / dual-compartment / Aluminum / NPT ½ in			W2

Table 1: Excerpt from ordering information

Overview – Electrical connections

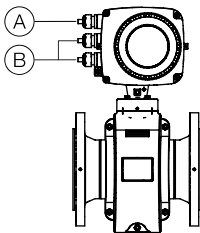
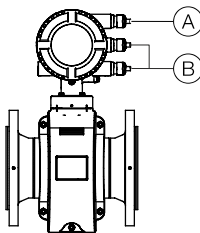
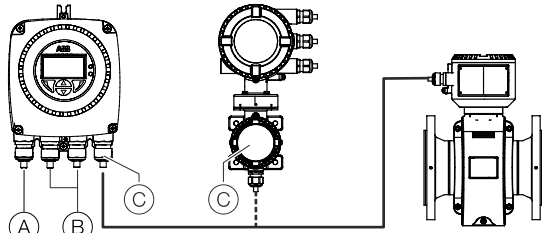
Single-compartment housing	Dual-compartment housing	Single- / dual-compartment housing – Remote mount design
		
<p>(A) Power supply</p> <ul style="list-style-type: none"> Type of protection ATEX / IECEx: Increased safety 'Ex e' Maximum 250 Vrms Terminals: 1+, 2-, L, N, \perp 	<p>(A) Power supply</p> <ul style="list-style-type: none"> Type of protection ATEX / IECEx: Increased safety 'Ex e' Maximum 250 Vrms Terminals: 1+, 2-, L, N, \perp 	<p>(C) Signal cable (remote mount design only)</p> <ul style="list-style-type: none"> Type of protection ATEX / IECEx: Increased safety 'Ex e' Terminals: A, B, UFE, GRN
<p>(B) Inputs/outputs, communication</p> <ul style="list-style-type: none"> Type of protection ATEX / IECEx: Increased safety 'Ex e' Terminals: 31, 32, Uco, V1, V2, V3, V4, 41, 42, 51, 52 	<p>(B) Inputs / outputs, communication</p> <ul style="list-style-type: none"> Type of protection ATEX / IECEx: Increased safety 'Ex e' or intrinsically safety 'Ex ia' When installing in 'Ex ia' or 'IS', Barriers must be used. Terminals: 31, 32, Uco, V1, V2, V3, V4, 41, 42, 51, 52 	

Devices in integral mount design

The transmitter and the flowmeter sensor form a single mechanical entity. The transmitter is available in two housing designs:

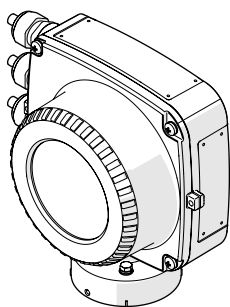

Single-compartment housing:

This is suited for use in ATEX/IECEX Zone 2, 22.

In the single-compartment housing, the electronics chamber and the connection chamber in the transmitter are not separated from each other.

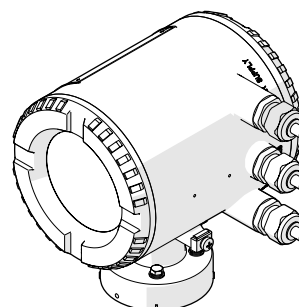

Dual-compartment housing:

This is suited for use in ATEX/IECEX Zone 1, 21, 2, 22.

In the dual-compartment housing, the electronics chamber and the connection chamber in the transmitter are separated from each other.

Figure 1: Transmitter housing designs



Note

Further information on the Ex Approval of devices can be found in the type examination certificates or the relevant certificates at www.abb.com/flow.



... 2 Device designs

... Devices in integral mount design

ATEX / IECEx Zone 1 – Devices with HART®, Modbus®, Profibus®, any analog Plug-in Card

Sensor	
<p>ProcessMaster 630 FEP631-A1, FEW631-A1</p> 	<p>HygienicMaster 630 FEH631-A1</p> 
<p>ATEX approval Certificate: FM17ATEX0016X</p> <p>DN 3 to 300 All I/O 's intrinsic safe: II 2 (1) G Ex db eb ib mb [ia Ga] IIC T6...T1 Gb II 2 (1) D Ex tb [ia Da] IIIC T80°C...T_{medium} Db All I/O 's Non intrinsic safe: II 2 (1) G Ex db eb ib mb IIC T6...T1 Gb II 2 (1) D Ex tb IIIC T80°C...T_{medium} Db</p> <p>DN 350 to 2000 All I/O 's intrinsic safe: II 2 (1) G Ex db eb ib [ia Ga] IIC T6...T1 Gb II 2 (1) D Ex tb [ia Da] IIIC T80°C...T_{medium} Db All I/O 's Non intrinsic safe: II 2 (1) G Ex db eb ib IIC T6...T1 Gb II 2 (1) D Ex tb IIIC T80°C...T_{medium} Db</p>	<p>ATEX approval Certificate: FM17ATEX0016X</p> <p>DN 3 to 100 All I/O 's intrinsic safe: II 2 (1) G Ex db eb ib mb [ia Ga] IIC T6...T1 Gb II 2 (1) D Ex tb [ia Da] IIIC T80°C...T_{medium} Db All I/O 's Non intrinsic safe: II 2 (1) G Ex db eb ib mb IIC T6...T1 Gb II 2 (1) D Ex tb IIIC T80°C...T_{medium} Db</p>
<p>IECEx approval Certificate: IECEx FME 17.0001X</p> <p>DN 3 to 300 All I/O 's intrinsic safe: II 2 (1) G Ex db eb ib mb [ia Ga] IIC T6...T1 Gb II 2 (1) D Ex tb [ia Da] IIIC T80°C...T_{medium} Db All I/O 's Non intrinsic safe: II 2 (1) G Ex db eb ib mb IIC T6...T1 Gb II 2 (1) D Ex tb IIIC T80°C...T_{medium} Db</p> <p>DN 350 to 2000 All I/O 's intrinsic safe: II 2 (1) G Ex db eb ib [ia Ga] IIC T6...T1 Gb II 2 (1) D Ex tb [ia Da] IIIC T80°C...T_{medium} Db All I/O 's Non intrinsic safe: II 2 (1) G Ex db eb ib IIC T6...T1 Gb II 2 (1) D Ex tb IIIC T80°C...T_{medium} Db</p>	<p>IECEx approval Certificate: IECEx FME 17.0001X</p> <p>DN 3 to 100 All I/O 's intrinsic safe: II 2 (1) G Ex db eb ib mb [ia Ga] IIC T6...T1 Gb II 2 (1) D Ex tb [ia Da] IIIC T80°C...T_{medium} Db All I/O 's Non intrinsic safe: II 2 (1) G Ex db eb ib mb IIC T6...T1 Gb II 2 (1) D Ex tb IIIC T80°C...T_{medium} Db</p>

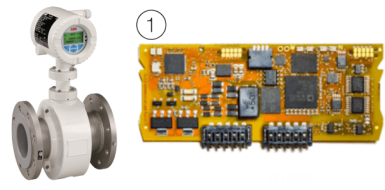
ATEX / IECEx Zone 1 – Devices with Ethernet-APL™ (Ordercode DR7)





Sensor	
<p>ProcessMaster 630 FEP631-A1, FEW631-A1</p> 	<p>HygienicMaster 630 FEH631-A1</p> 
<p>ATEX approval Certificate: FM17ATEX0016X</p> <p>DN 3 to 300 All I/O 's intrinsic safe: 2-WISE power load, APL field device FISCO II 2 (1) G Ex db eb ib mb [ia Ga] IIC T6...T1 Gb II 2 (1) D Ex tb [ia Da] IIIC T80°C...T_{medium} Db</p>	<p>ATEX approval Certificate: FM17ATEX0016X</p> <p>DN 3 to 100 All I/O 's intrinsic safe: 2-WISE power load, APL field device FISCO II 2 (1) G Ex db eb ib mb [ia Ga] IIC T6...T1 Gb II 2 (1) D Ex tb [ia Da] IIIC T80°C...T_{medium} Db</p>
<p>DN 350 to 2000 All I/O 's intrinsic safe: 2-WISE power load, APL field device FISCO II 2 (1) G Ex db eb ib [ia Ga] IIC T6...T1 Gb II 2 (1) D Ex tb [ia Da] IIIC T80°C...T_{medium} Db</p>	
<p>IECEx approval Certificate: IECEx FME 17.0001X</p> <p>DN 3 to 300 All I/O 's intrinsic safe: 2-WISE power load, APL field device FISCO II 2 (1) G Ex db eb ib mb [ia Ga] IIC T6...T1 Gb II 2 (1) D Ex tb [ia Da] IIIC T80°C...T_{medium} Db</p>	<p>IECEx approval Certificate: IECEx FME 17.0001X</p> <p>DN 3 to 100 All I/O 's intrinsic safe: 2-WISE power load, APL field device FISCO II 2 (1) G Ex db eb ib mb [ia Ga] IIC T6...T1 Gb II 2 (1) D Ex tb [ia Da] IIIC T80°C...T_{medium} Db</p>
<p>DN 350 to 2000 All I/O 's intrinsic safe: 2-WISE power load, APL field device FISCO II 2 (1) G Ex db eb ib [ia Ga] IIC T6...T1 Gb II 2 (1) D Ex tb [ia Da] IIIC T80°C...T_{medium} Db</p>	

① Ethernet-APL plug-In card; Ethernet-APL is available with ATEX / IECEx Zone 1 and dual compartment housing



... 2 Device designs

... Devices in integral mount design



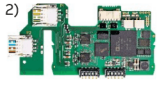

ATEX / IECEx Zone 2 – Devices with HART®, Modbus®, Profibus®, any analog Plug-in Card

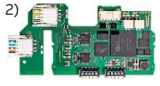
Sensor	
ProcessMaster 630 FEP631-A2, FEW631-A2	HygienicMaster 630 FEH631-A2
1)  2) 	1)  2) 
ATEX approval Certificate ATEX: FM17ATEX0017X II 3G Ex ec IIC T6...T1 Gc II 3D Ex tc IIIC T80°C...T _{medium} Dc	ATEX approval Certificate ATEX: FM17ATEX0017X II 3G Ex ec IIC T6...T1 Gc II 3D Ex tc IIIC T80°C...T _{medium} Dc
IECEx approval Certificate: IECEx FME 17.0001X II 3G Ex ec IIC T6...T1 Gc II 3D Ex tc IIIC T80°C...T _{medium} Dc	IECEx approval Certificate: IECEx FME 17.0001X II 3G Ex ec IIC T6...T1 Gc II 3D Ex tc IIIC T80°C...T _{medium} Dc
1) Single-compartment housing 2) Dual-compartment housing	

ATEX / IECEx Zone 2 – Devices with standard Ethernet plug-in card (Ordercode DR6)

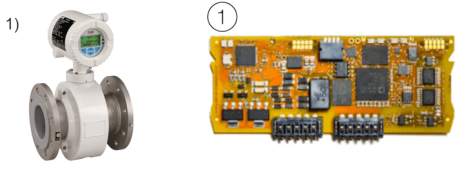
Sensor	
ProcessMaster 630 FEP631-A2, FEP631-U2; FEW631-A2, FEW631-U2	HygienicMaster 630 FEH631-A2, FEH631-U2
1)  2) 	1)  2) 
ATEX / UKEX Certificate ATEX: FM17ATEX0017X Certificate UKEX: FM21UKEX0032X II 3G Ex ec IIC T4...T1 Gc II 3D Ex tc IIIC T80 °C...T _{medium} Dc	ATEX / UKEX Certificate ATEX: FM17ATEX0017X Certificate UKEX: FM21UKEX0032X II 3G Ex ec IIC T4...T1 Gc II 3D Ex tc IIIC T80 °C...T _{medium} Dc
IEC Certificate: IECEx FME 17.0001X II 3G Ex ec IIC T4...T1 Gc II 3D Ex tc IIIC T80 °C...T _{medium} Dc	IEC Certificate: IECEx FME 17.0001X II 3G Ex ec IIC T4...T1 Gc II 3D Ex tc IIIC T80 °C...T _{medium} Dc
1) Single-compartment housing 2) Plug-In Card for standard Ethernet	

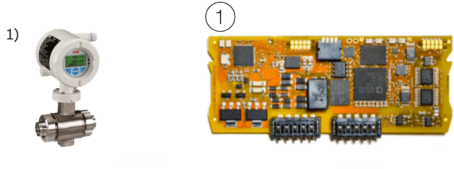
ATEX / IECEx Zone 2 – Devices with Ethernet-APL™ (Ordercode DR7)

Sensor	
ProcessMaster 630 FEP631-A2, FEW631-A2	HygienicMaster 630 FEH631-A2
 <p>1)  </p>	 <p>1)  </p>
ATEX approval Certificate: FM17ATEX0016X All I/O´s non intrinsic safe 2-WISE power load, APL field device II 3G Ex ec IIC T6...T1 Gc II 3D Ex tc IIIC T80°C...T _{medium} Dc All I/O´s intrinsic safe: II 3G Ex ec ic IIC T6...T1 Gc II 3D Ex tb ib IIIC T80°C...T _{medium} Dc	ATEX approval Certificate: FM17ATEX0016X All I/O´s non intrinsic safe 2-WISE power load, APL field device II 3G Ex ec IIC T6...T1 Gc II 3D Ex tc IIIC T80°C...T _{medium} Dc All I/O´s intrinsic safe: II 3G Ex ec ic IIC T6...T1 Gc II 3D Ex tb ib IIIC T80°C...T _{medium} Dc
IECEx approval Certificate: IECEx FME 17.0001X All I/O´s non intrinsic safe: 2-WISE power load, APL field device II 3G Ex ec IIC T6...T1 Gc II 3D Ex tc IIIC T80°C...T _{medium} Dc All I/O´s intrinsic safe: II 3G Ex ec ic IIC T6...T1 Gc II 3D Ex tb ib IIIC T80°C...T _{medium} Dc	IECEx approval Certificate: IECEx FME 17.0001X All I/O´s non intrinsic safe: 2-WISE power load, APL field device II 3G Ex ec IIC T6...T1 Gc II 3D Ex tc IIIC T80°C...T _{medium} Dc All I/O´s intrinsic safe: II 3G Ex ec ic IIC T6...T1 Gc II 3D Ex tb ib IIIC T80°C...T _{medium} Dc

1) Dual-compartment housing

 Ethernet-APL plug-In card

... 2 Device designs

Devices in remote mount design

The transmitter is mounted in a separate location from the flowmeter sensor. The electrical connection between the transmitter and flowmeter sensor may only be established using the signal cable supplied.

A maximum signal cable length of 200 m (656 ft) is possible.

Note

Further information on the Ex Approval of devices can be found in the type examination certificates or the relevant certificates at www.abb.com/flow.

ATEX / IECEx Zone 1 – Flowmeter sensor

⚠ DANGER

Explosion hazard caused by incorrect transmitter installation

The FET632-Y0 transmitter does not have Ex Approval.

The FET632-Y0 transmitter may not be installed and operated in potentially explosive atmospheres.

The following table presents the combination of the FEP632, FEW632 and FEH632 flowmeter sensor in explosion-proof design with the FET632 transmitter.

Flowmeter sensor

ProcessMaster 630

FEP632-A1, FEW632-A1

In Ex area, Zone 1, 21



ATEX approval

Certificate ATEX: FM17ATEX0016X

DN 3 to 300:

II 2 G Ex eb ib mb IIC T6...T1 Gb

II 2 D Ex tb IIIC T80°C...T_{medium} Db

DN 350 to 2000:

II 2 G Ex eb ib IIC T6...T1 Gb

II 2 D Ex tb IIIC T80°C...T_{medium} Db

IECEx approval

Certificate: IECEx FME 17.0001X

DN 3 to 300:

II 2 G Ex eb ib mb IIC T6...T1 Gb

II 2 D Ex tb IIIC T80°C...T_{medium} Db

DN 350 to 2000:

II 2 G Ex eb ib IIC T6...T1 Gb

II 2 D Ex tb IIIC T80°C...T_{medium} Db

HygienicMaster 630

FEH632-A1

In Ex area, Zone 1, 21



ATEX approval

Certificate ATEX: FM17ATEX0016X

DN 3 to 100:

II 2 G Ex eb ib mb IIC T6...T1 Gb

II 2 D Ex tb IIIC T80°C...T_{medium} Db

IECEx approval

Certificate: IECEx FME 17.0001X

DN 3 to 100:

II 2 G Ex eb ib mb IIC T6...T1 Gb

II 2 D Ex tb IIIC T80°C...T_{medium} Db

Note

FEW632 is available from DN 25 (1 in).

ATEX / IECEx Zone 2 – Flowmeter sensor**⚠ DANGER****Explosion hazard caused by incorrect transmitter installation**

The FET632-Y0 transmitter does not have Ex Approval.

The FET632-Y0 transmitter may not be installed and operated in potentially explosive atmospheres.

The following table presents the combination of the FEP632, FEW632 and FEH632 flowmeter sensor in explosion-proof design with the FET632 transmitter.

Flowmeter sensor**ProcessMaster 630**

FEP632-A2, FEW632-A2

In Ex area, Zone 2, 22

**ATEX approval**

Certificate ATEX: FM17ATEX0017X

II 3G Ex ec IIC T6...T1 Gc

II 3D Ex tc IIIC T80°C...T_{medium} Dc

IECEx approval

Certificate: IECEx FME 17.0001X

II 3G Ex ec IIC T6...T1 Gc

II 3D Ex tc IIIC T80°C...T_{medium} Dc

HygienicMaster 630

FEH632-A2

In Ex area, Zone 2, 22

**ATEX approval**

Certificate ATEX: FM17ATEX0017X

II 3G Ex ec IIC T6...T1 Gc

II 3D Ex tc IIIC T80°C...T_{medium} Dc

IECEx approval

Certificate: IECEx FME 17.0001X

II 3G Ex ec IIC T6...T1 Gc

II 3D Ex tc IIIC T80°C...T_{medium} Dc

Note

FEW632 is available from DN 25 (1 in).

... 2 Device designs

... Devices in remote mount design

ATEX / IECEx Zone 1, 2 – Transmitter

Transmitter in ATEX / IECEx Zone 1

Transmitter

FET632-A1W1 or FET632-A1W2

In Ex area ATEX/IECEX Zone 1

With HART, Modbus, Profibus, any analog Plug-in Card²⁾



FET632-A1W1 or FET632-A1W2

In Ex area ATEX/IECEX Zone 1

With Ethernet-APL™ plug-in card (Ordercode DR7)¹⁾

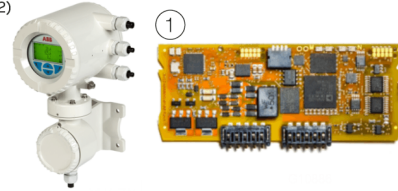

ATEX approval

Certificate ATEX: FM17ATEX0016X

All I/O 's intrinsic safe:

II 2 (1) G Ex db eb mb [ia Ga] IIC T6 Gb

II 2 (1) D Ex tb [ia Da] IIIC T80°C Db

All I/O 's non intrinsic safe:

II 2 (1) G Ex db eb mb IIC T6 Gb

II 2 (1) D Ex tb IIIC T80°C Db

IECEX approval

Certificate: IECEx FME 17.0001X

All I/O 's intrinsic safe:

II 2 (1) G Ex db eb mb [ia Ga] IIC T6 Gb

II 2 (1) D Ex tb [ia Da] IIIC T80°C Db

All I/O 's non intrinsic safe:

II 2 (1) G Ex db eb mb IIC T6 Gb

II 2 (1) D Ex tb IIIC T80°C Db

ATEX approval

Certificate ATEX: FM17ATEX0017X

All I/O 's intrinsic safe:

2-WISE power load, APL field device FISCO

II 2 (1) G Ex db eb mb [ia Ga] IIC T6 Gb FISCO

II 2 (1) D Ex tb [ia Da] IIIC T80°C Db FISCO

IECEX approval

Certificate: IECEx FME 17.0001X

All I/O 's intrinsic safe:

2-WISE power load, APL field device FISCO

II 2 (1) G Ex db eb mb [ia Ga] IIC T6 Gb FISCO

II 2 (1) D Ex tb [ia Da] IIIC T80°C Db FISCO

²⁾ Dual-compartment housing (Modelcode FET632-A1W1 or FET632-A1W2)

¹⁾ Plug-In Card for Ethernet APL, available with dual compartment housing

Transmitter in ATEX / IECEx Zone 2

Transmitter

FET632-A2F1, FET632-A2F2

FET632-A2W1 or FET632-A2W2

FET632-A2F1 or FET632-A2F2

FET632-Y0

or

FET632-A2W1, FET632-A2W2

In Ex area ATEX/IECEX Zone 2

In Ex area ATEX/IECEX Zone 2

Outside the Ex area

In Ex area ATEX/IECEX Zone 2

With Ethernet-APL™ plug-in card (Ordercode 'DR7')

With standard Ethernet plug-in card (Modelcode 'DR6')

With HART, Modbus, Profibus, any analog plug-in card

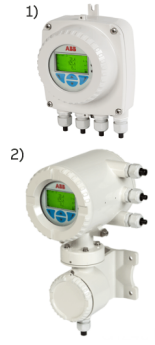
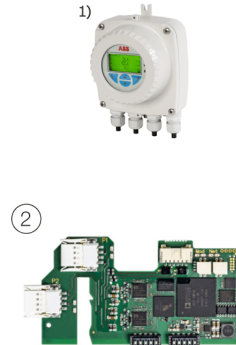
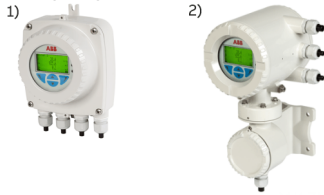

ATEX approval

ATEX approval

ATEX approval

—

Certificate ATEX: FM17ATEX0016X
II 3G Ex ec IIC T6 Gc
II 3D Ex tc IIIC T80°C Dc

Certificate ATEX: FM17ATEX0017X
All I/O 's non intrinsic safe:
2-WISE power load, APL field device
II 3G Ex ec IIC T6 Gc
II 3D Ex tc IIIC T80°C Dc
All I/O 's intrinsic safe:
II 3G Ex ec ic IIC T6 Gc
II 3D Ex tb ib IIIC T80°C Dc

Certificate ATEX: FM17ATEX0017X
II 3G Ex ec IIC T4...T1 Gc
II 3D Ex tc IIIC T80°C Dc

No Ex Approval!

IEC

IEC

Certificate: IECEx FME 17.0001X

—

Certificate: IECEx FME 17.0001X
II 3G Ex ec IIC T6 Gc
II 3D Ex tc IIIC T80°C Dc

Certificate: IECEx FME 17.0001X
All I/O 's non intrinsic safe:
2-WISE power load, APL field device
II 3G Ex ec IIC T6 Gc
II 3D Ex tc IIIC T80°C Dc
All I/O 's intrinsic safe:
II 3G Ex ec ic IIC T6 Gc
II 3D Ex tb ib IIIC T80°C Dc

Certificate: IECEx FME 17.0001X
II 3G Ex ec IIC T4...T1 Gc
II 3D Ex tc IIIC T80°C Dc

No Ex Approval!

1) Single-compartment housing

2) Dual-compartment housing

① Ethernet-APL plug-in card, available with dual compartment housing

② Standard Ethernet plug-in card, available with single compartment housing

4 Housing

Opening and closing the housing

⚠ DANGER

Danger of explosion if the device is operated with the transmitter housing or terminal box open!

Before opening the transmitter housing or the terminal box, note the following points:

- A valid fire permit must be present.
- Make sure that there is no explosion hazard.
- Switch off the power supply and wait for $t > 20$ minutes before opening.

⚠ WARNING

Risk of injury due to live parts!

When the housing is open, explosion protection and contact protection is not provided and EMC protection is limited.

- Before opening the housing, switch off the power supply.

Dual- compartment housing

NOTICE

Potential adverse effect on the IP rating

- Check the O-ring gasket for damage and replace it if necessary before closing the housing cover.
- Check that the O-ring gasket is properly seated when closing the housing cover.

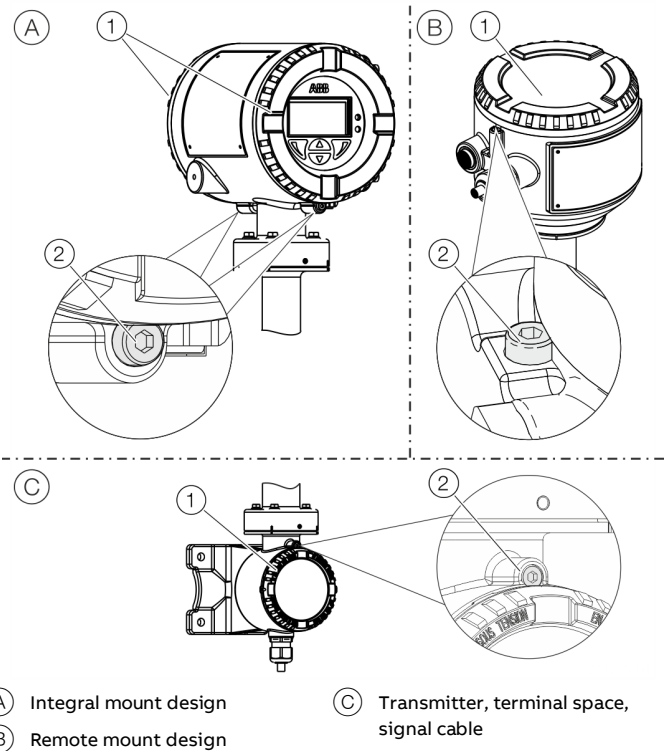

Figure 3: Cover lock (example)

Open the housing:

1. Release the cover lock by screwing in the Allen screw (2).
2. Unscrew cover (1).

Close the housing:

1. Screw on the cover (1).
2. After closing the housing, lock the cover by unscrewing the Allen screw (2).

... 4 Housing

... Opening and closing the housing

Single-compartment housing

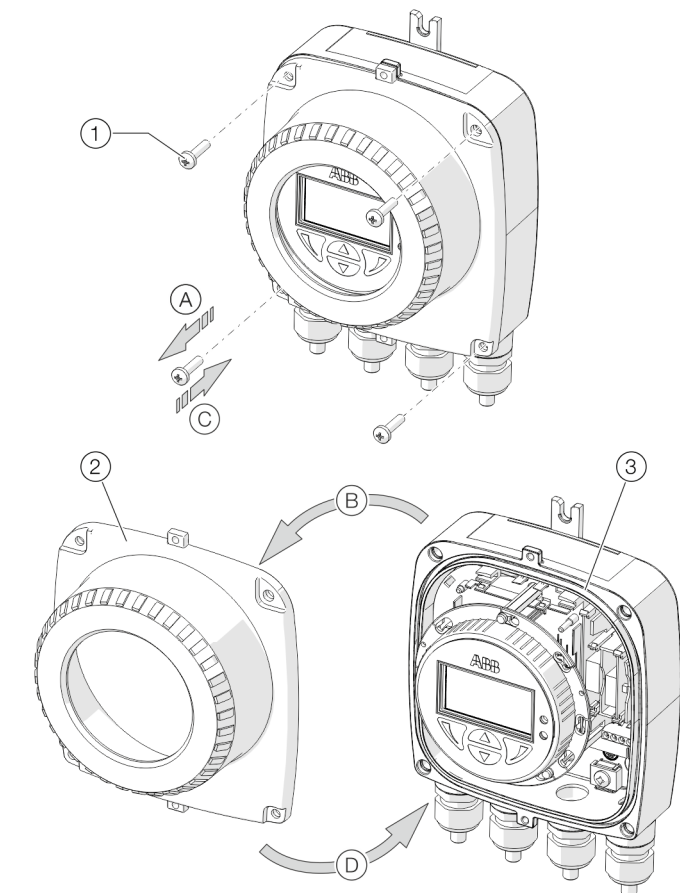

- ① Cover screws ③ Gasket
 ② Transmitter housing cover

Figure 4: Open / close single-compartment housing

Open the housing:

- Perform steps (A) and (B).

Close the housing:

- Perform steps (C) and (D).

Rotating the transmitter housing and LCD display

Depending on the installation position, the transmitter housing or LCD display can be rotated to enable horizontal readings.

Transmitter housing

⚠ DANGER

Damaging the device carries a risk of explosion!

When the screws for the transmitter housing are loosened, the explosion protection is suspended.

- Tighten all screws prior to commissioning.
- Never disconnect the transmitter housing from the sensor.
- Loosen only the screws indicated when rotating the transmitter housing!

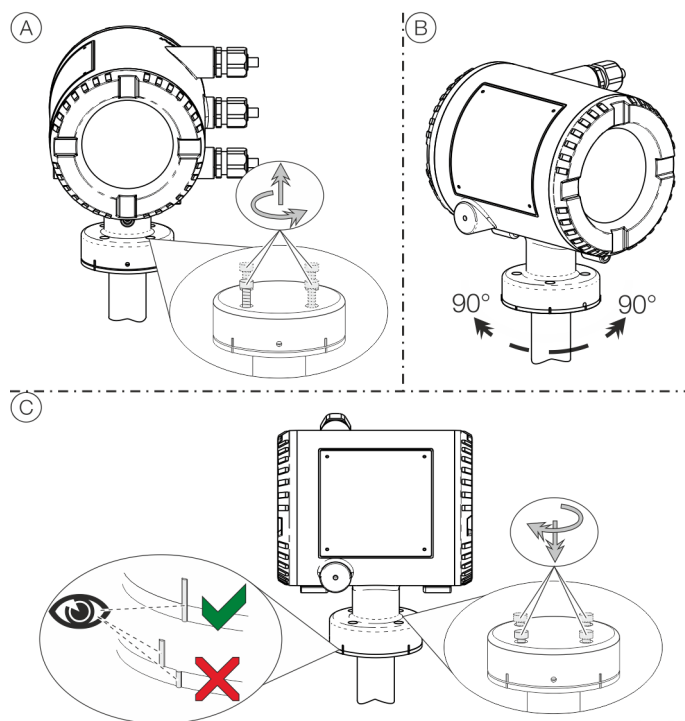

Figure 5: Rotate transmitter housing

Rotate the housing:

- Perform steps (A) to (C).

Installation instructions

ATEX / IECEX

The installation, commissioning, maintenance and repair of devices in potentially explosive atmospheres must only be carried out by appropriately trained personnel. Works may be carried out only by persons, whose training has included instructions on different types of protection and installation techniques, concerned rules and regulations as well as general principles of zoning.

The person must possess the appropriate competences for the type of work to be conducted.

The safety instructions for electrical apparatus in potentially explosive areas must be in accordance with Directive 2014/34/EU (ATEX) and IEC 60079-14 (Installation of electrical equipment in potentially explosive areas).

Comply with the applicable regulations for the protection of employees to ensure safe operation.

Use in areas exposed to combustible dust

When using the device in areas exposed to combustible dusts (dust ignition), the following points must be observed:

- The maximum surface temperature of the device may not up-scale the following values.

FEP631, FEW631; FEH631	80 °C (176 °F)
FEP632, FEW632; FEH632	80 °C (176 °F)
FET632	80 °C (176 °F)
- The process temperature of the attached piping may up-scale 80 °C (176 °F).
- Approved dust-proof cable glands must be used when operating in Zone 21, 22 or in Class II, Class III.
- In potentially explosive atmospheres, the signal cable must measure at least 5 m (16.40 ft).

Cable entry

The devices are supplied with cable glands installed (certified in accordance with ATEX or IECEX).

- The use of standard cable glands and closures is prohibited.
- The black plugs in the cable glands are intended to provide protection during transport.
- The outside diameter of the connection cable must measure between 6 mm (0.24 in) and 12 mm (0.47 in) to guarantee the required tightness.
- Black cable glands are installed by default when the device is supplied. If signal outputs are connected to intrinsically safe circuits, replace the black cap on the corresponding cable gland with the blue one supplied.
- Any unused cable entries must be sealed before commissioning in accordance with the applicable standards.

Note

Low-temperature version devices (optional, up to -40 °C (-40 °F) ambient temperature) are supplied with metal cable glands due to the required temperature resistance.

... 4 Housing

Electrical connections

Temperature resistance for the connecting cable

The temperature at the cable entries of the device is dependent on the measuring medium temperature T_{medium} and the ambient temperature T_{amb} .

For the electrical connection of the device, use only cables with sufficient temperature resistance in accordance with the following table.

Device in integral mount design

T_{amb}	Temperature resistance
$\leq 50\text{ °C}$ ($\leq 122\text{ °F}$)	$\geq 60\text{ °C}$ ($\geq 140\text{ °F}$)
$\leq 60\text{ °C}$ ($\leq 140\text{ °F}$)	$\geq 70\text{ °C}$ ($\geq 158\text{ °F}$)

Model in remote mount design

T_{amb}	Temperature resistance
$\leq 50\text{ °C}$ ($\leq 122\text{ °F}$)	$\geq 70\text{ °C}$ ($\geq 158\text{ °F}$)
$\leq 60\text{ °C}$ ($\leq 140\text{ °F}$)	$\geq 80\text{ °C}$ ($\geq 176\text{ °F}$)

Grounding

The sensor must be grounded in accordance with the applicable international standards.

Perform grounding of the device in accordance with **Electrical connections** on page 27 or **Electrical connections** on page 40.

High temperature design

The high temperature design available with FEP630 and FEH630 allows for complete thermal insulation of the sensor, up to the maximum illustrated device height.

The pipeline and sensor must be insulated after installing the unit according to the following illustration.

The thermal resistance of the insulation may not up-scale $\lambda = 0.036\text{ W}/(\text{mK})$; if it does, the thickness of the insulation must be reduced accordingly.

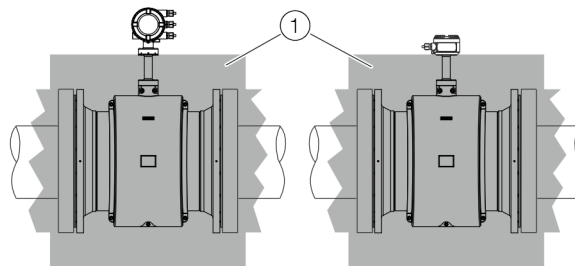

① Insulation

Figure 6: Insulation

5 Digital communication

Standard Ethernet communication

Standard Ethernet 10/100 BASE-T/TX (IEEE802.3)

⚠ DANGER

Explosion hazard due to improper installation!

The standard Ethernet plug-in card and the plug-in card for 'Power over Ethernet (POE)' is Ex approved for use in Zone 2 / Division 2 hazardous areas only.

- Use in Zone 1 / Division 1 is not permitted!

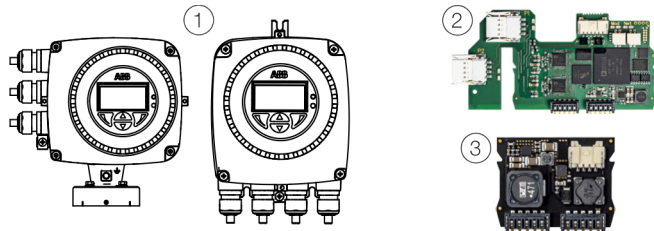

- ① Transmitter (single-compartment housing)
- ② Standard Ethernet (various protocols) (green)
Order no.: 3KQZ400037U0100
- ③ Power over Ethernet (POE) for Standard Ethernet (blue)
Order no.: 3KQZ400039U0100

Figure 7: Standard Ethernet plug-in card

The standard Ethernet plug-in card is only available in combination with the single-chamber housing.

The output-circuit-design allows for connecting to different topologies such as daisy chain or point to point. It is not permitted to combine both topologies.

The rated voltage of these non-intrinsically safe circuits are $U_M = 57 \text{ V}$.

For details, see **Installation diagram 3KXF000061G0009** on page 63.

Ethernet connection to remote or integral design transmitter

The following possibilities are given to connect the transmitter enclosures.

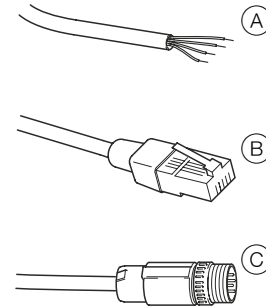

- Ⓐ Connection via a cable gland
- Ⓑ Cable connection via RJ45 connector
- Ⓒ Cable connection via M12 connector

Figure 8: Connection possibilities of the Ethernet cable

Note

For detailed information on the electrical connection of the standard Ethernet interface, refer to the chapter 'Digital communication' in the operating instruction 'OI/FEP630/FEW630/FEH630' or the commissioning instruction 'CI/FEP630/FEW630/FEH630'.

... 5 Digital communication





... Standard Ethernet communication

M12 connector (optional)

A variety of options are available for the M12 connector through the model code:



- Flowmeter equipped with 1 × M12 (four-wire, connection to Port 1)
- Flowmeter equipped with 2 × M12 (four-wire, connection to Port 1 and 2)
- Flowmeter equipped with 1 × M12 (eight-wire, connection to Port 1 and 2)

These options enable connection to various network topologies:

Topology	Four-wire	Four-wire	Four-wire	Eight-wire
				
	1 × M12 (four-wire)	2 × M12 (four-wire)	1 × M12 (eight-wire)	
Star	Y	Y	Y	Y
Ring or daisy chain	N	Y	N	N
PoE	N	N	Y	Y

Electrical connections

You can reference the internal wiring in the transmitter and the corresponding pin assignment in the M12 connector in the following table:

Internal wiring	M12 connector pin	Color	Std .Ethernet plug-in card Connector/pin
 <p>M12 connector four-wire</p>	1	Yellow	Port 1 X1
	2	Orange	Port 1 X2
	3	White	Port 1 X3
	4	Blue	Port 1 X4
 <p>M12 connector eight-wire</p>	1	White	Port 1 X1
	2	Blue	Port 1 X2
	3	Brown	Port 1 X3
	4	Green	Port 1 X4
	5	Pink	Port 1 X5
	6	Yellow	Port 1 X6
	7	Grey	Port 1 X7
	8	Red	Port 1 X8

Use in Potentially Explosive Atmospheres

WARNING

There are limitations to the M12 connector in combination with an ATEX / IECEx / EAC-Ex approved flowmeter.

	No Ex area	ATEX/IECEX/ EAC-Ex Zone 2	Div 2
Ethernet cable connected directly to the terminals of the standard	Y	Y	Y
Ethernet plug-in card			
Ethernet cable connected to the M12 connector on the transmitter housing	Y	Y	N

Locking clip

WARNING

A locking clip must be attached when using the M12 connector in combination with an ATEX / IECEx / EAC-Ex approved flowmeter.

- Use or operation of the device without the M12 locking clip is not permitted.

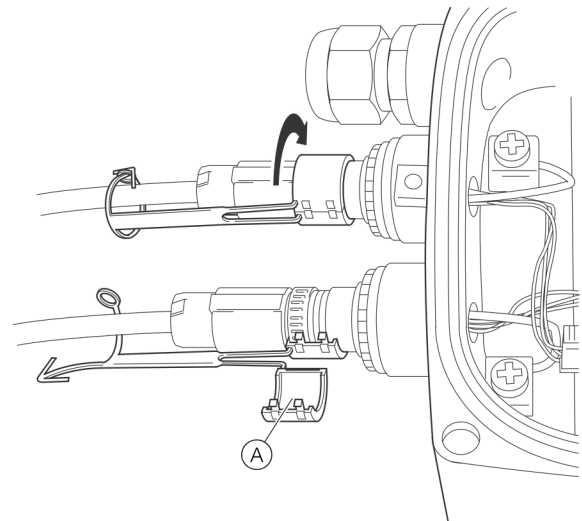

(A) Locking clip

Figure 9: Fastening the locking clip

DANGER

Explosion hazard

Explosion hazard caused by connecting or disconnecting the M12 connector when the device is in live state.

- Connect or disconnect the M12 connector only if the device is de-energized.

1. Remove the sealing cap of the M12 metal connector on the transmitter housing when delivered.
2. Connect the customer-provided M12 connector cable.
3. Place the enclosed locking clip around the M12 connector and close it until the locking clip engages, then secure the locking clip by closing the pin and pin boss.



RJ45 connector (optional)

A variety of options are available for the RJ45 connector through the model code: The RJ45 connector is equipped with an Ethernet cable of a specific length, depending on the model code.

The flowmeter is supplied with an Ethernet cable, which is connected to the terminals in the transmitter at the factory.

- Flowmeter equipped with 1 × RJ45 (four-wire, connection to Port 1)
- Flowmeter equipped with 2 × RJ45 (four-wire, connection to Port 1 and 2)
- Flowmeter equipped with 1 × RJ45 (eight-wire, connection to Port 1 and 2)

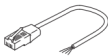
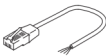
These options enable connection to various network topologies:

Topology	Four-wire	Four-wire	Four-wire	Eight-wire
				
	1 x RJ45 (four-wire)	2 x M12 (four-wire)		1 x RJ45 (eight-wire)
Star	Y		Y	Y
Ring or daisy chain	N		Y	N
PoE	N		N	Y

Electrical connections

You can reference the in the transmitter and the corresponding pin assignment in the RJ45 connector in the following table:

Internal wiring	Color	Standard Ethernet plug-in card Port/pin
RJ45 four-wire	Yellow	Port 1 X1
	Orange	Port 1 X2
	White	Port 1 X3
	Blue	Port 1 X4
RJ45 eight-wire	White/orange	Port 1 X1
	Orange	Port 1 X2
	White/Green	Port 1 X3
	Green	Port 1 X4
	White/blue	Port 2 X5
	Blue	Port 2 X6
	White/brown	Port 2 X7
	Brown	Port 2 X8

Use in potentially explosive atmospheres

WARNING

There are limitations to the RJ45 connector in combination with an ATEX / IECEx / EAC-Ex approved flowmeter.

	No Ex area	ATEX/IECEX/E	Div 2
		AC-Ex	Zone 2
Ethernet cable with RJ45 connector mounted to the transmitter housing	Y	Y	N

... 5 Digital communication

... Standard Ethernet communication

Ground the Ethernet connection cable

Connect the outer shield of the Ethernet cable to the screw terminal.

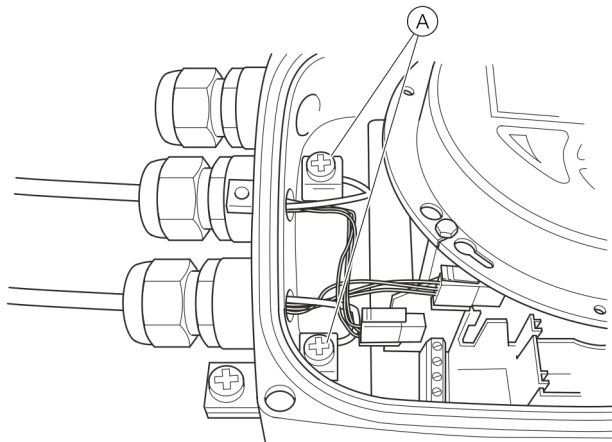

(A) Screw terminal

Figure 10: Ground the Ethernet connection cable

Electrical Data

Refer to chapter **Electric data for operation in Zone 1, 21** on page 29.

Ethernet APL™ communication

Ethernet-APL™ 10BASE-T1L (IEEE 802.3cg)

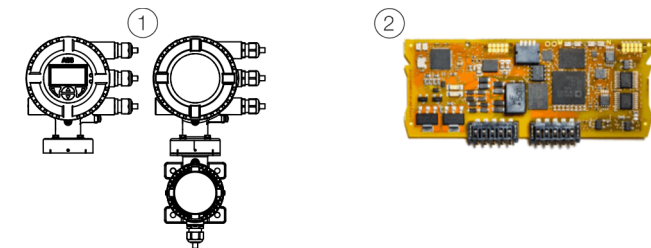

- ① Transmitter (dual-compartment housing)
 ② Ethernet-APL™ (various protocols) (yellow)
 Order No.: 3KQZ400067U0100

Figure 11: Standard Ethernet plug-in card

⚠ DANGER

Explosion hazard due to improper installation!

The "Ethernet-APL" plug-in card is approved for use in potentially explosive areas in Zone 1, 2 / Division 1, 2 with type of protection "Ex i – intrinsic safety (Intrinsic safety)" or "Ex e – Increased safety (Increased safety)".

- Comply with the following instructions for use in Zone 1, 2 / Division 1, 2!

Notes for use in Zone 1 and Division 1:

The transmitter features 2 Slots for plug-in cards. With the Ethernet-APL Card utilizing one Slot, there is the option for another analog I/O plug-in card.

If the "Ethernet-APL" plug-in card is used in combination with other plug-in cards, all plug-in cards and output circuits must be designed in type of protection "Ex i – intrinsic safety (Intrinsic safety)". In this case the "Ethernet-APL" plug-in card must not be used for type of protection "Ex e – Increased safety (Increased safety)".

Notes for use in Zone 2 and Division 2:

The transmitter features 2 Slots for plug-in cards. With the Ethernet-APL Card utilizing one Slot, there is the option for another analog I/O plug-in card.

If the "Ethernet-APL" plug-in card is used in combination with other plug-in cards, all plug-in cards and output circuits must be designed either in type of protection "Ex i – intrinsic safety (Intrinsic safety)" or "Ex e – Increased safety (Increased safety)".

Power Over Ethernet (POE)

The "Ethernet-APL" plug-in card must not be used in combination with the "Power-Over-Ethernet (POE)" plug-in card.

Ethernet-APL™ connection to remote or integral design transmitter

The Ethernet-APL cable is connected to the flowmeter transmitter terminals V1/V2.

Connect the shield of the Ethernet cable as shown by the figure below.

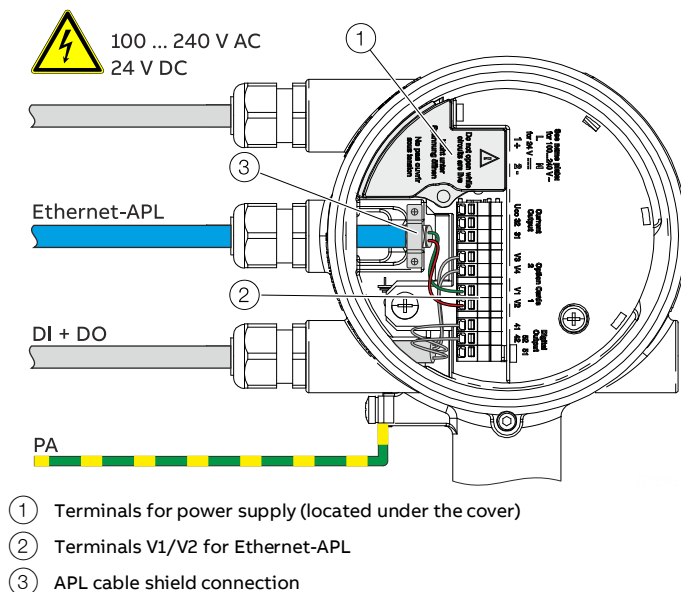

Figure 12: Connection of the Ethernet-APL cable

Note

For detailed information on the electrical connection of the Ethernet-APL interface, refer to the chapter 'Digital communication' in the operating instruction 'OI/FEP630/FEW630/FEH630' or the commissioning instruction 'CI/FEP630/FEW630/FEH630'.

Electrical Data

Refer to chapter **Electrical data for operation in Zone 2, 22** on page 42.

6 Installing the plug-in cards

⚠ WARNING

Loss of Ex Approval!

Loss of Ex Approval due to retrofitting of plug-in cards on devices for use in potentially explosive atmospheres.

- Devices for use in potentially explosive atmospheres may not be retrofitted with plug-in cards.
- If devices are to be used in potentially explosive atmospheres, the required plug-in cards must be specified when the order is placed.

Note

The AS plug-in card (24 V DC loop power supply) may only be used to power the internal inputs and outputs on the device. It must not be used to power external circuits!

Optional plug-in cards

The transmitter has two slots (OC1, OC2) into which plug-in cards can be inserted to extend inputs and outputs. The slots are located on the transmitter motherboard and can be accessed after removing the front housing cover.

Plug-in cards

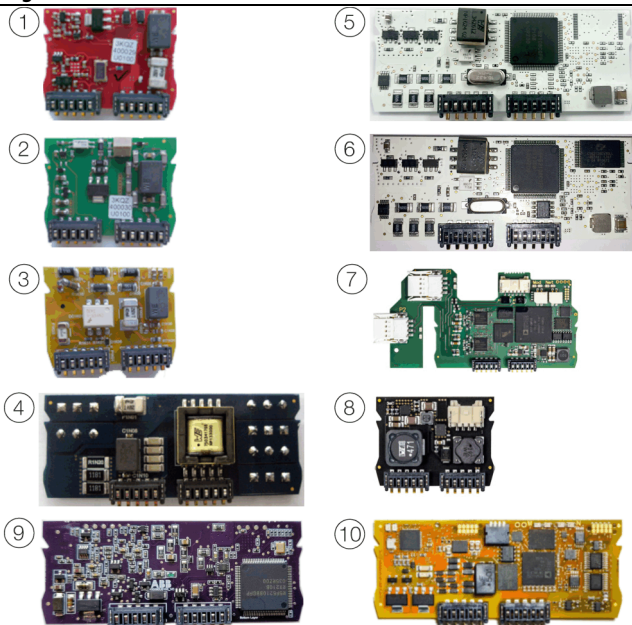

Pos.	Description	Quantity*
①	Current output, 4 to 20 mA passive (red) Order no.: 3KQZ400029U0100	2
②	Passive digital output (green) Order no.: 3KQZ400030U0100	1**
③	Passive digital input (yellow) Order no.: 3KQZ400032U0100	1
④	24 V DC voltage supply (blue) Order no.: 3KQZ400031U0100	1
⑤	Modbus RTU® RS485 (white) Order no.: 3KQZ400028U0100	1
⑥	PROFIBUS DP® (white) Order no.: 3KQZ400027U0100	1
⑦	Standard Ethernet (various protocols) (green) Order no.: 3KQZ400037U0100	1
⑧	Power over Ethernet (POE) for Standard Ethernet (blue) Order no.: 3KQZ400039U0100	1
⑨	PROFIBUS PA® (blue) Order no.: 3KQZ400061U0100	1**
⑩	Ethernet-APL™ (various protocols) (yellow) Order No.: 3KQZ400067U0100	1

* The 'Number' column indicates the maximum number of plug-in cards of the same type that can be used.

** Only one plug-in card of passive digital output type can be inserted in Pos. ②.

7 Operation in Zone 1, 21

Electrical connections

Single compartment housing (integral and remote version)

Sensor FEP632, FEW632, FEH632
in Zone 1 / Div. 1

Transmitter FET632 in Zone 2, Div. 2

FET632 transmitter in safe area (No Ex area)

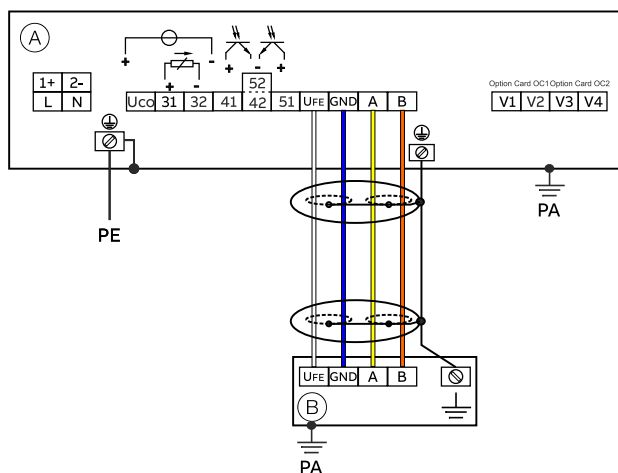
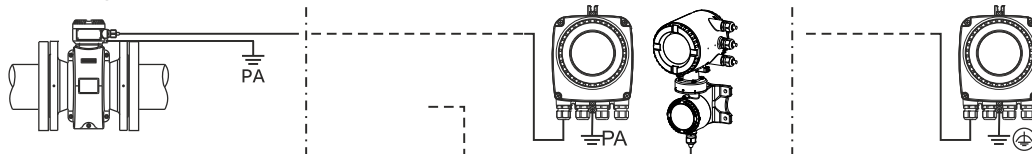

(A) Transmitter

(B) Remote sensor

Figure 13: Electrical connections single compartment housing

Dual compartment housing (remote version)

Sensor FEP632, FEW632, FEH632 and transmitter FET632 in Zone 1 / Div. 1

Sensor FEP631, FEW631, FEH631 in Zone 1 / Div. 1

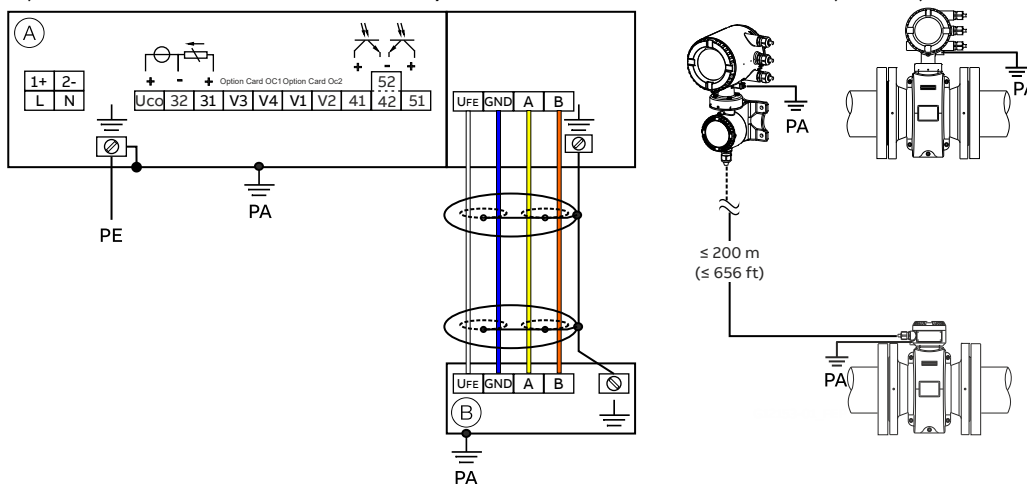

(A) Transmitter

(B) Remote sensor

Figure 14: Electrical connections dual compartment housing

... 7 Operation in Zone 1, 21

... Electrical connections

Note

For detailed information about grounding the transmitter and the flowmeter sensor, please refer to chapter 'Grounding' in the Commissioning instruction or the operating instruction.

Connections for the power supply

AC power supply

Terminal	Function / comments
L	Phase
N	Neutral conductor
PE / ⊕	Protective earth (PE)
	Functional earth / shielding

DC voltage supply

Terminal	Function / comments
1+	+
2-	-
PE / ⊕	Protective earth (PE)
	Functional earth / shielding

Connections for inputs and outputs

Terminal	Function / comments
Uco / 32	Current output 4 to 20 mA- / HART output, active or
31 / 32	Current output 4 to 20 mA- / HART output, passive
41 / 42	Passive digital output DO1
51 / 52	Passive digital output DO2
V1 / V2	Plug-in card, slot OC1
V3 / V4	Plug-in card, slot OC2
Plug-in cards may not be retrofitted in devices with explosion protection on-site – loss of Ex Approval.	

Connecting the signal cable

Only for remote mount design.

The sensor housing and transmitter housing must be connected to potential equalization.

Terminal	Function / comments
U _{FE}	Sensor power supply
GND	Ground
A	Data line
B	Data line
	Functional earth / Shielding

Electric data for operation in Zone 1, 21

Model: FEP631, FEW631, FEH631 or FET632	Type of protection														
	'e' / 'XP'		'ia' / 'IS'												
Outputs on basic device	U_M	I_M	U_O	U_I	I_O	I_I	P_O	P_I	C_O	C_I	C_{OPA}	C_{IPA}	L_O [mH]	L_I	
	[V]	[A]		[V]	[mA]	[mA]	[mW]	[mW]	[nF]	[nF]	[nF]	[nF]		[mH]	
Current / HART output 31 / U_{CO}, active Terminals 31 / U_{CO}	30	0.2	30	30	115	115	815	815	10	10	5	5	0.08	0.08	
Current / HART output 31 / 32, passive Terminals 31 / 32	30	0.2	—	30	—	115	—	815	—	27	—	5	0.08	0.08	
Digital output 41 / 42, active* Terminals 41 / 42 and V1 / V2*	30	0.1	27.8	30	119	30	826	225	20	20	29	29	0.22	0.22	
Digital output 41 / 42, passive Terminals 41 / 42	30	0.1	—	30	—	30	—	225	—	27	—	5	—	0.08	
Digital output 51 / 52, active* Terminals 51 / 52 and V1 / V2*	30	0.1	27.8	30	119	30	826	225	20	20	29	29	0.22	0.22	
Digital output 51 / 52, passive Terminals 51 / 52	30	0.1	—	30	—	30	—	225	—	27	—	5	—	0.08	

All outputs are electrically isolated from each other and from the power supply.

Digital outputs 41 / 42 and 51 / 52 are not electrically isolated from each other. Terminals 42 / 52 have the same potential.

... 7 Operation in Zone 1, 21

... Electric data for operation in Zone 1, 21

Model: FEP631, FEW631, FEH631 or FET632	Type of protection														
Inputs and outputs with optional plug-in cards	'e' / 'XP'		'ia' / 'IS'												
	U _M [V]	I _M [A]	U _O	U _I [V]	I _O [mA]	I _I [mA]	P _O [mW]	P _I [mW]	C _O [nF]	C _I [nF]	C _{OPA} [nF]	C _{IPA} [nF]	L _O [mH]	L _I [mH]	
Current output V3 / V4, active* Terminals V3 / V4 and V1 / V2*	30	0.1	27.8	30	119	30	826	225	29	29	117	117	0.4	0.4	
Current output V1 / V2, passive** Current output V3 / V4, passive** Terminals V1 / V2** or V3 / V4**	30	0.1	—	30	—	68	—	510	—	45	—	59	—	0.27	
Digital output V3 / V4, active* Terminals V3 / V4 and V1 / V2*	30	0.1	27.8	30	119	68	826	225	17	17	31	31	0.4	0.4	
Digital output V1 / V2, passive** Digital output V3 / V4, passive** Terminals V1 / V2** or V3 / V4**	30	0.1	—	30	—	30	—	225	—	13	—	16	—	0.27	
Digital input V3 / V4, active* Terminals V3 / V4 and V1 / V2	30	0.1	27.8	30	119	3.45	826	25.8	17	17	31	31	0.4	0.4	
Digital input V1 / V2, passive* Digital input V3 / V4, passive* Terminals V1 / V2** or V3 / V4**	30	0.1	—	30	—	3.45	—	25.8	—	13	—	16	—	0.27	
Modbus Card (RTU) Terminals V1 / V2	30	0.1	4.2	4.2	150	150	150	150	5300	5300	0.06	0.06	0.09	0.09	
PROFIBUS DP Terminals V1 / V2	30	0.1	4.2	4.2	150	150	150	150	5300	5300	0.06	0.06	0.09	0.09	
PROFIBUS PA (Non-FISCO) Terminals V1 / V2	30	0.38	—	30	—	100	—	815	—	4	—	—	0	0.008	
PROFIBUS PA (FISCO) Terminals V1 / V2	—	—	—	17.5	—	380	—	5320	—	4	—	—	0	0.008	
Ethernet-APL Terminals V1 / V2	—	—	—	17.5	—	380	—	5320	—	1	—	1	—	0.001	

* Only in conjunction with additional '24 V DC loop power supply (blue)' plug-in card in slot OC1.

** The terminal assignment depends on the model number or the slot assignments. For connection examples, refer to **Installation** in the operating instruction.

For devices in Zone 1 / Div. 1 the bus termination must conform to the FISCO model or the explosion protection regulations, respectively.

Special conditions

Zone 1/12 – Certificate No. FM17ATEX0016X and FM21UKEX0033X

1. The painted surface of the FE*6, ProcessMaster and HygenicMaster may store electrostatic charge and become a source of ignition in applications with a low relative humidity <~30 % relative humidity where the painted surface is relatively free of surface contamination such as dirt, dust, or oil.
Guidance on protection against the risk of ignition due to electrostatic discharge can be found in IEC TR60079-32-2
Cleaning of the painted surface should only be done with a damp cloth.
2. For installations in flammable dust, the cable entries shall be fitted with an appropriate cable entry device meeting the requirements of IP 6x fitted with a gasket or seal between the cable entry device and the wall of the enclosure.
3. For Integral and Remote versions FE*63*A1 Category II 2 D having exposed electrodes in the process shall be used in a non-flammable liquid process only.
4. Contact the manufacturer for specific flameproof joint details during repair of flameproof Ex d apparatus.
5. The ABB Instruction Manual for the ProcessMaster and HygenicMaster details the permitted Temperature Classification and Ambient Temperature ratings as influenced by the Process Medium temperature.

Special connection conditions

Note

The AS plug-in card (24 V DC loop power supply) may only be used to power the internal inputs and outputs on the device. It must not be used to power external circuits!

Note

If the protective earth (PE) is connected in the flowmeter's terminal box, you must ensure that no dangerous potential difference can arise between the protective earth (PE) and the potential equalization (PA) in areas with explosion risk.

Note

For devices with a power supply of 16 to 30 V DC, on-site external overvoltage protection must be provided. It must be ensured that the overvoltage is limited to 140 % (= 42 V DC) of the maximum operating voltage.

The output circuits are designed so that they can be connected to both intrinsically-safe and non-intrinsically-safe circuits.

- Combining intrinsically safe and non-intrinsically safe circuits is not permitted.
- On intrinsically safe circuits, potential equalization should be established along the entire length of the cable used for the signal outputs.
- The rated voltage of the non-intrinsically safe circuits is $U_M = 30 \text{ V}$.
- Intrinsic safety is preserved if the rated voltage $U_M = 30 \text{ V}$ is not up-scaled when connections are established to non-intrinsically safe external circuits.
- Once output circuits are connected and have been operated for a while, a change of the protection (intrinsically safe and vice versa) is not permitted.
- During Commissioning the type of protection used (intrinsically safe or non-intrinsically safe) should be indicated on the device by attaching a Tag.

The concept of intrinsic safety allows several approved intrinsically safe devices to be interconnected without additional intrinsic safety installation checks, if the relevant installation standards are observed.

Devices connected to the relevant equipment must not be operated at over 250 V_{rms} AC or 250 V DC to ground.

Installation in accordance with ATEX or IECEx must comply with the applicable national and international standards and directives.

... 7 Operation in Zone 1, 21

... Special conditions

Protection against electrostatic discharges

DANGER

Explosion hazard due to electrostatic charging!

The painted surface of the device can store electrostatic charges.

As a result, the housing can form an ignition source due to electrostatic discharges in the following conditions:

- The device is operated in environments with a relative humidity of $\leq 30\%$.
- The painted surface of the device is thereby relatively free from impurities such as dirt, dust or oil.
- Instructions on avoiding ignition in potentially explosive environments due to electrostatic discharges in accordance with PD CLC/TR 60079-32-1 and IEC TS 60079-32-1 must be complied with!

Instructions on cleaning

The painted surface of the device must be cleaned only using a moist cloth.

Repair

Devices of type of protection 'd / XP' are equipped with flameproof joints in the housing. Contact ABB before commencing repair work.

Temperature data

Surface temperature

Model name	Surface temperature
FEP632, FEW632, FEH632	T 80 °C (176 °F)
FEP631, FEW631, FEH631	T 80 °C (176 °F)
FET632	T 80 °C (176 °F)

The surface temperature depends on the fluid temperature.

With increasing measuring medium temperature > 60 °C (140 °F) or > 80 °C (176 °F), the surface temperature also increases to the level of the measuring medium temperature.

Note

The maximum permissible measuring medium temperature depends on the liner and flange material, and is limited by the operating values in the following tables.

Measuring medium temperature as a function of liner and flange material

Model FEP631, FEP632; FEW631, FEW632		Measuring medium temperature range (operating data)	
Lining material	Flange material	Minimum	Maximum
Hard rubber	Steel	-10 °C (14 °F)	85 °C (185 °F)
		-5 °C (23 °F)*	80 °C (176 °F)*
Hard rubber	Stainless steel	-15 °C (5 °F)	85 °C (185 °F)
		-5 °C (23 °F)*	80 °C (176 °F)*
Soft rubber	Steel	-10 °C (14 °F)	60 °C (140 °F)
Soft rubber	Stainless steel	-15 °C (5 °F)	60 °C (140 °F)
PTFE	Steel	-10 °C (14 °F)	130 °C (266 °F)
PTFE	Stainless steel	-25 °C (-13 °F)	130 °C (266 °F)
PFA	Steel	-10 °C (14 °F)	180 °C (356 °F)
PFA	Stainless steel	-25 °C (-13 °F)	180 °C (356 °F)
Thick PTFE	Steel	-10 °C (14 °F)	180 °C (356 °F)
Thick PTFE	Stainless steel	-25 °C (-13 °F)	180 °C (356 °F)
ETFE	Steel	-10 °C (14 °F)	130 °C (266 °F)
ETFE	Stainless steel	-25 °C (-13 °F)	130 °C (266 °F)

* Only for China production site

Note

ProcessMaster FEW631 + FEW632 is available with hard rubber only.

Model FEH631, FEH632			Fluid temperature (operating values)	
Liner	Process connection	Material	Minimum	Maximum
PFA	Flange	Stainless steel	-25 °C (-13 °F)	180 °C (356 °F)
PFA	Wafer type	—	-25 °C (-13 °F)	130 °C (266 °F)
PFA	Variable process connection	Stainless steel	-25 °C (-13 °F)	130 °C (266 °F)

... 7 Operation in Zone 1, 21

... Temperature data

Measuring medium temperature (Ex Data) for ProcessMaster Model FEP631



Nominal diameter	Design	Temperature class	Ambient temperature (-40 °C)* -20 °C to +40 °C		Ambient temperature (-40 °C)* -20 °C to +50 °C		Ambient temperature (-40 °C)* -20 °C to +60 °C	
			thermally uninsulated, thermally insulated		thermally uninsulated, thermally insulated		thermally uninsulated, thermally insulated	
			Gas & dust		Gas & dust		Gas & dust	
DN3 to 2000	NT	T1	130 °C		130 °C		130 °C	
	HT		180 °C		180 °C		180 °C	
	NT	T2	130 °C		130 °C		130 °C	
	HT		180 °C		180 °C		180 °C	
	NT	T3	130 °C		130 °C		130 °C	
	HT		180 °C		180 °C		180 °C	
	NT	T4	130 °C		130 °C		130 °C	
	HT		130 °C		130 °C		130 °C	
	NT	T5	95 °C		95 °C		95 °C	
	HT		95 °C		95 °C		95 °C	
	NT	T6	80 °C		80 °C		80 °C	
	HT		80 °C		80 °C		80 °C	

* Low-temperature version (option)

NT standard version, T_{medium} maximum 130 °C (266 °F)

HT high-temperature version, T_{medium} maximum 180 °C (356 °F)

Thermally uninsulated: the sensor is not enclosed with pipe insulation material.

Thermally insulated: the sensor is enclosed with pipe insulation material.

Note

Cables for power supply, signal inputs and outputs must meet the following specifications:

- At an ambient temperature ≤ 50 °C the cable must be suited for at least 60 °C
- At an ambient temperature ≤ 60 °C the cable must be suited for at least 70 °C

Measuring medium temperature (Ex Data) for ProcessMaster Model FEP632



Nominal diameter	Design	Temperature class	Ambient temperature	Ambient temperature	Ambient temperature
			(-40 °C)* -20 °C to +40 °C	(-40 °C)* -20 °C to +50 °C	(-40 °C)* -20 °C to +60 °C
			thermally uninsulated, thermally insulated	thermally uninsulated, thermally insulated	thermally uninsulated, thermally insulated
			Gas & dust	Gas & dust	Gas & dust
DN 3 to 2000	NT	T1	130°C	130°C	130°C
	HT	T1	180°C	180°C	180°C
	NT	T2	130°C	130°C	130°C
	HT	T2	180°C	180°C	180°C
	NT	T3	130°C	130°C	130°C
	HT	T3	180°C	180°C	180°C
	NT	T4	130°C	130°C	130°C
	HT	T4	130°C	130°C	130°C
	NT	T5	95°C	95°C	95°C
	HT	T5	95°C	95°C	95°C
	NT	T6	80°C	80°C	80°C
	HT	T6	80°C	80°C	80°C

* Low-temperature version (option)

NT standard version, T_{medium} maximum 130 °C (266 °F)

HT high-temperature version, T_{medium} maximum 180 °C (356 °F)

Thermally uninsulated: the sensor is not enclosed with pipe insulation material.

Thermally insulated: the sensor is enclosed with pipe insulation material.

Note

Cables for power supply, signal inputs and outputs must meet the following specifications:

- At an ambient temperature ≤ 50 °C the cable must be suited for at least 70 °C
- At an ambient temperature ≤ 60 °C the cable must be suited for at least 80 °C

... 7 Operation in Zone 1, 21

... Temperature data

Measuring medium temperature (Ex Data) for ProcessMaster Model FEW631



Nominal diameter	Design	Temperature class	Ambient temperature	Ambient temperature	Ambient temperature
			-20 °C to +40 °C	-20 °C to +50 °C	-20 °C to +60 °C
			thermally uninsulated, thermally insulated	thermally uninsulated, thermally insulated	thermally uninsulated, thermally insulated
			Gas & dust	Gas & dust	Gas & dust
DN25 to 3000	NT	T1	80 °C (176 °F)*	80 °C (176 °F)*	80 °C (176 °F)*
	NT	T2	80 °C (176 °F)*	80 °C (176 °F)*	80 °C (176 °F)*
	NT	T3	80 °C (176 °F)*	80 °C (176 °F)*	80 °C (176 °F)*
	NT	T4	80 °C (176 °F)*	80 °C (176 °F)*	80 °C (176 °F)*
	NT	T5	80 °C (176 °F)*	80 °C (176 °F)*	80 °C (176 °F)*
	NT	T6	80 °C (176 °F)	80 °C (176 °F)	80 °C (176 °F)

* The limiting Factor for the measuring medium temperature is the Sensor liner material. It is limited to 80 °C (176 °F)

NT standard version, T_{medium} maximum 80 °C (176 °F)

Thermally uninsulated: the sensor is not enclosed with pipe insulation material.

Thermally insulated: the sensor is enclosed with pipe insulation material.

Note

Cables for power supply, signal inputs and outputs must meet the following specifications:

- At an ambient temperature ≤ 50 °C the cable must be suited for at least 60 °C
- At an ambient temperature ≤ 60 °C the cable must be suited for at least 70 °C

Measuring medium temperature (Ex Data) for ProcessMaster Model FEW632



Nominal diameter	Design	Temperature class	Ambient temperature	Ambient temperature	Ambient temperature
			-20 °C to +40 °C	-20 °C to +50 °C	-20 °C to +60 °C
			thermally uninsulated, thermally insulated	thermally uninsulated, thermally insulated	thermally uninsulated, thermally insulated
			Gas & dust	Gas & dust	Gas & dust
DN25 to 3000	NT	T1	80 °C (176 °F)*	80 °C (176 °F)*	80 °C (176 °F)*
	NT	T2	80 °C (176 °F)*	80 °C (176 °F)*	80 °C (176 °F)*
	NT	T3	80 °C (176 °F)*	80 °C (176 °F)*	80 °C (176 °F)*
	NT	T4	80 °C (176 °F)*	80 °C (176 °F)*	80 °C (176 °F)*
	NT	T5	80 °C (176 °F)*	80 °C (176 °F)*	80 °C (176 °F)*
	NT	T6	80 °C (176 °F)	80 °C (176 °F)	80 °C (176 °F)

* The limiting Factor for the measuring medium temperature is the Sensor liner material. It is limited to 80 °C (176 °F)

NT standard version, T_{medium} maximum 80 °C (176 °F)

Thermally uninsulated: the sensor is not enclosed with pipe insulation material.

Thermally insulated: the sensor is enclosed with pipe insulation material.

Note

Cables for power supply, signal inputs and outputs must meet the following specifications:

- At an ambient temperature ≤ 50 °C the cable must be suited for at least 70 °C
- At an ambient temperature ≤ 60 °C the cable must be suited for at least 80 °C

... 7 Operation in Zone 1, 21

... Temperature data

Measuring medium temperature (Ex Data) for HygienicMaster Model FEH631

HT + NT design



NT design only



Nominal diameter	Design	Temperature class	Ambient temperature (-40 °C)* -20 °C to +40 °C	Ambient temperature (-40 °C)* -20 °C to +50 °C	Ambient temperature (-40 °C)* -20 °C to +60 °C
			thermally uninsulated, thermally insulated	thermally uninsulated, thermally insulated	thermally uninsulated, thermally insulated
			Gas & dust	Gas & dust	Gas & dust
DN3 to 2000	NT	T1	130 °C	130 °C	130 °C
	HT		180 °C	180 °C	180 °C
	NT	T2	130 °C	130 °C	130 °C
	HT		180 °C	180 °C	180 °C
	NT	T3	130 °C	130 °C	130 °C
	HT		180 °C	180 °C	180 °C
	NT	T4	130 °C	130 °C	130 °C
	HT		130 °C	130 °C	130 °C
	NT	T5	95 °C	95 °C	95 °C
	HT		95 °C	95 °C	95 °C
	NT	T6	80 °C	80 °C	80 °C
	HT		80 °C	80 °C	80 °C

* Low-temperature version (option)

NT standard version, T_{medium} maximum 130 °C (266 °F)

HT high-temperature version, T_{medium} maximum 180 °C (356 °F)

Thermally uninsulated: the sensor is not enclosed with pipe insulation material.

Thermally insulated: the sensor is enclosed with pipe insulation material.

Note

Cables for power supply, signal inputs and outputs must meet the following specifications:

- At an ambient temperature ≤ 50 °C the cable must be suited for at least 60 °C
- At an ambient temperature ≤ 60 °C the cable must be suited for at least 70 °C

Measuring medium temperature (Ex Data) for HygienicMaster Model FEH632

HT + NT design



NT design only



Nominal diameter	Design	Temperature class	Ambient temperature (-40 °C)* -20 °C to +40 °C	Ambient temperature (-40 °C)* -20 °C to +50 °C	Ambient temperature (-40 °C)* -20 °C to +60 °C
			thermally uninsulated, thermally insulated	thermally uninsulated, thermally insulated	thermally uninsulated, thermally insulated
			Gas & dust	Gas & dust	Gas & dust
DN3 to 2000	NT	T1	130°C	130°C	130°C
	HT		180°C	180°C	180°C
	NT	T2	130°C	130°C	130°C
	HT		180°C	180°C	180°C
	NT	T3	130°C	130°C	130°C
	HT		180°C	180°C	180°C
	NT	T4	130°C	130°C	130°C
	HT		130°C	130°C	130°C
	NT	T5	95°C	95°C	95°C
	HT		95°C	95°C	95°C
	NT	T6	80°C	80°C	80°C
	HT		80°C	80°C	80°C

* Low-temperature version (option)

NT standard version, T_{medium} maximum 130 °C (266 °F)

HT high-temperature version, T_{medium} maximum 180 °C (356 °F)

Thermally uninsulated: the sensor is not enclosed with pipe insulation material.

Thermally insulated: the sensor is enclosed with pipe insulation material.

Note

Cables for power supply, signal inputs and outputs must meet the following specifications:

- At an ambient temperature ≤ 50 °C the cable must be suited for at least 70 °C
- At an ambient temperature ≤ 60 °C the cable must be suited for at least 80 °C

8 Operation in Zone 2, 22

Electrical connections

Single compartment housing (integral and remote version)

Sensor FEP632, FEW632, FEH632
in Zone 2 / Div. 2

Transmitter FET632 in Zone 2, Div. 2

FET632 transmitter in safe area (No Ex area)

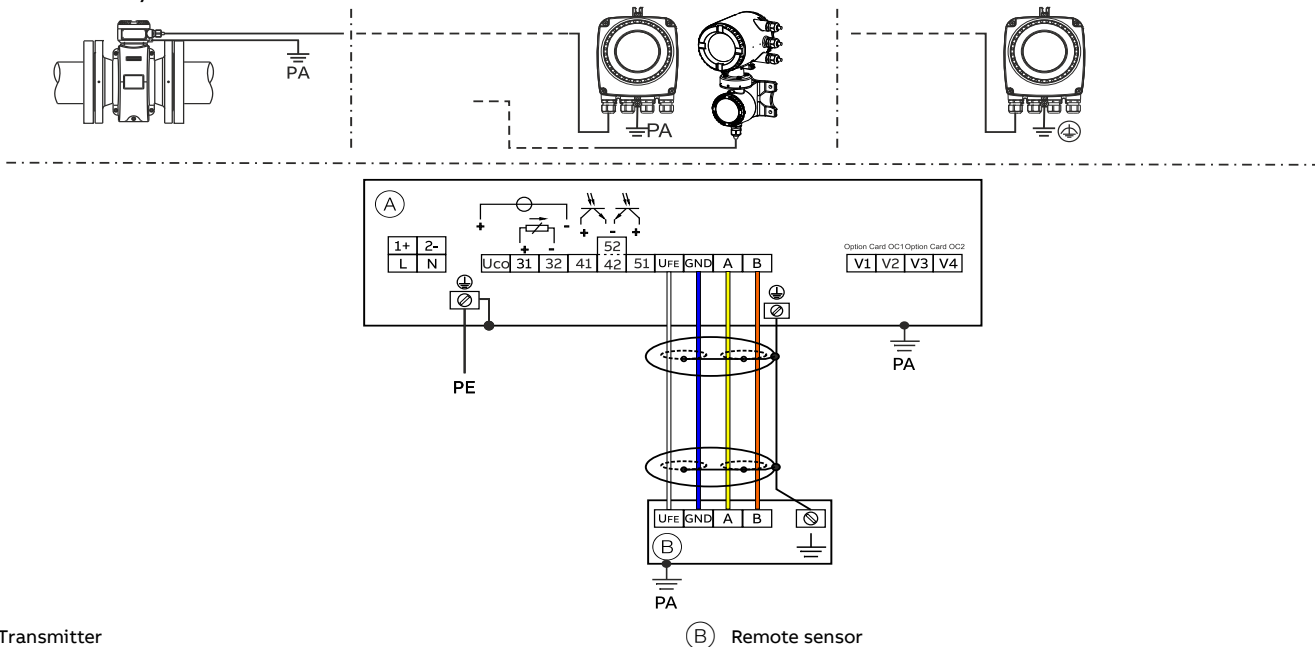

(A) Transmitter

(B) Remote sensor

Figure 15: Electrical connections single compartment housing

Dual compartment housing (remote version)

Sensor FEP632, FEW632, FEH632 and transmitter FET632 in Zone 2 / Div. 2

Sensor FEP631, FEW631, FEH631 in Zone 2 / Div. 2

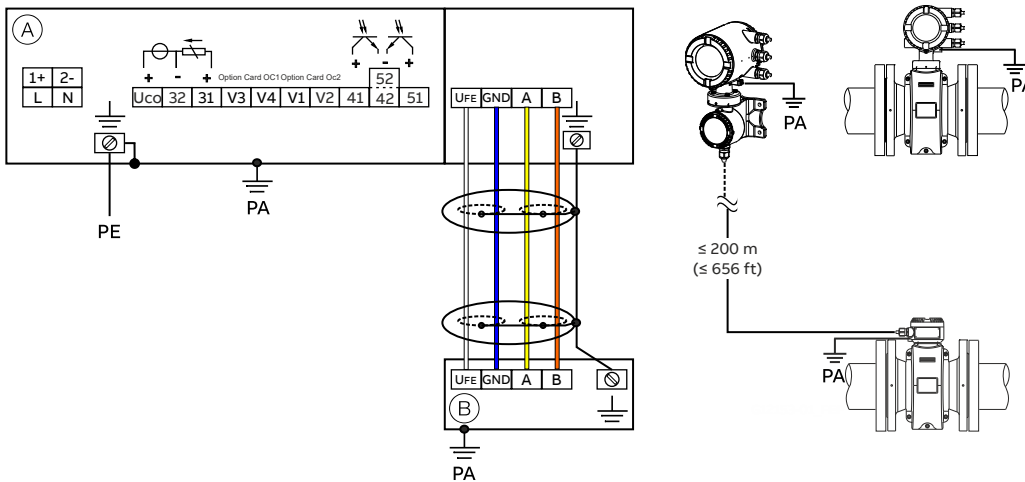

(A) Transmitter



(B) Remote sensor

Figure 16: Electrical connections dual compartment housing



Note

For detailed information about grounding the transmitter and the flowmeter sensor, please refer to chapter 'Grounding' in the Commissioning instruction or the operating instruction.

Connections for the power supply**AC power supply**

Terminal	Function / comments
L	Phase
N	Neutral conductor
PE / 	Protective earth (PE)
	Functional earth / shielding

DC voltage supply

Terminal	Function / comments
1+	+
2-	-
PE / 	Protective earth (PE)
	Functional earth / shielding

Connections for inputs and outputs

Terminal	Function / comments
Uco / 32	Current output 4 to 20 mA- / HART output, active or
31 / 32	Current output 4 to 20 mA- / HART output, passive
41 / 42	Passive digital output DO1
51 / 52	Passive digital output DO2
V1 / V2	Plug-in card, slot OC1
V3 / V4	Plug-in card, slot OC2
	Plug-in cards may not be retrofitted in devices with explosion protection on-site – loss of Ex Approval.

Connecting the signal cable

Only for remote mount design.

The sensor housing and transmitter housing must be connected to potential equalization.

Terminal	Function / comments
U_{FE}	Sensor power supply
GND	Ground
A	Data line
B	Data line
	Functional earth / Shielding

... 8 Operation in Zone 2, 22

Electrical data for operation in Zone 2, 22

Model: FEP631; FEW631, FEH631 or FET632

Outputs on basic device	Operating values (general)		Type of protection – 'nA' / 'NI' / 'ec'	
	U_N	I_N	U_N	I_N
Current / HART output 31 / UCO, active Terminals 31 / UCO	30 V	30 mA	30 V	30 mA
Current / HART output 31 / 32, passive Terminals 31 / 32	30 V	30 mA	30 V	30 mA
Digital output 41 / 42, passive Terminals 41 / 42	30 V	25 mA	30 V	25 mA
Digital output 51 / 52, passive Terminals 51 / 52	30 V	30 mA	30 V	30 mA
Digital output 41 / 42, active* Terminals 41 / 42 and V1 / V2*	30 V	30 mA	30 V	30 mA
Digital output 51 / 52, active* Terminals 51 / 52 and V1 / V2*	30 V	30 mA	30 V	30 mA

* Only in conjunction with additional '24 V DC loop power supply (blue)' plug-in card in slot OC1.

All outputs are electrically isolated from each other and from the power supply.

Digital outputs 41 / 42 and 51 / 52 are not electrically isolated from each other. Terminals 42 / 52 have the same potential.

Model: FEP631; FEW631, FEH631 or FET632

Plug-in cards	Operating values (general)		Type of protection – 'nA' / 'NI' / 'ec'	
	U_N	I_N	U_N	I_N
Current output, active* Terminals V3 / V4 and V1 / V2**	30 V	30 mA	30 V	30 mA
Current output, passive Terminals V1 / V2 or V3 / V4**	30 V	30 mA	30 V	30 mA
Digital output, active* Terminals V3 / V4 and V1 / V2**	30 V	25 mA	30 V	25 mA
Digital output, passive Terminals V1 / V2 or V3 / V4**	30 V	30 mA	30 V	30 mA
Digital input, active* Terminals V3 / V4 and V1 / V2**	30 V	3.45 mA	30 V	3.45 mA
Digital input, passive Terminals V1 / V2 or V3 / V4**	30 V	3.45 mA	30 V	3.45 mA
Modbus Card (RTU) Terminals V1/V2	30 V	30 mA	30 V	30 mA
Profibus DP card Terminals V1/V2	30 V	30 mA	30 V	30 mA
Profibus PA card Terminals V1/V2	32 V	30 mA	32 V	30 mA
Standard Ethernet card Port 1: Pin X1 to X4 Port 2: Pin X5 to X8	57 V	417 mA	57 V	417 mA
Standard Ethernet Card in conjunction with Power over Ethernet (POE Card) Port 1: Pin X1 to X4 Port 2: Pin X5 to X8	57 V	417 mA	57 V	417 mA
Ethernet-APL™ Card Terminals V1/V2	17.5 V	380 mA	17.5 V	380 mA

* Only in conjunction with additional '24 V DC loop power supply (blue)' plug-in card in slot OC1.

** The terminal assignment relates to the Option Card Slot. Slot 1 = Terminals V1/V2. Slot 2 = Terminal V3/V4. For more details, refer to Installation in the operating instruction.

Special conditions

Zone 2/22 – Certificate No. FM17ATEX0017X and FM21UKEX0032X

1. Sensors having exposed electrodes in the process shall be used in a non-flammable liquid process only.
2. The ABB Instruction Manual for the ProcessMaster and HygenicMaster details the permitted Temperature Classification and Ambient Temperature ratings as influenced by the Process Medium temperature.
3. The painted surface of the ProcessMaster and HygenicMaster may store electrostatic charge and become a source of ignition in applications with a low relative humidity <~30 % relative humidity where the painted surface is relatively free of surface contamination such as dirt, dust, or oil.

Guidance on protection against the risk of ignition due to electrostatic discharge can be found in IEC TR60079-32-2
Cleaning of the painted surface should only be done with a damp cloth.

Special connection conditions

Note

The AS plug-in card (24 V DC loop power supply) may only be used to power the internal inputs and outputs on the device. It must not be used to power external circuits!

Note

If the protective earth (PE) is connected in the flowmeter's terminal box, you must ensure that no dangerous potential difference can arise between the protective earth (PE) and the potential equalization (PA) in areas with explosion risk.

Note

For devices with a power supply of 16 to 30 V DC, on-site external overvoltage protection must be provided. It must be ensured that the overvoltage is limited to 140 % (= 42 V DC) of the maximum operating voltage.

Note

With zone 2 devices and the inner of the adjacent pipe classified as hazardous area, a completely filled pipe must be ensured all the time.

Protection against electrostatic discharges

DANGER

Explosion hazard due to electrostatic charging!

The painted surface of the device can store electrostatic charges.

As a result, the housing can form an ignition source due to electrostatic discharges in the following conditions:

- The device is operated in environments with a relative humidity of $\leq 30\%$.
- The painted surface of the device is thereby relatively free from impurities such as dirt, dust or oil.
- Instructions on avoiding ignition in potentially explosive environments due to electrostatic discharges in accordance with PD CLC/TR 60079-32-1 and IEC TS 60079-32-1 must be complied with!

Instructions on cleaning

The painted surface of the device must be cleaned only using a moist cloth.

... 8 Operation in Zone 2, 22

Temperature data

Surface temperature

Model name	Surface temperature
FEP632, FEW632, FEH632	T 80 °C (176 °F)
FEP631, FEW631, FEH631	T 80 °C (176 °F)
FET632	T 80 °C (176 °F)

The surface temperature depends on the fluid temperature.

With increasing measuring medium temperature > 60 °C (140 °F) or > 80 °C (176 °F), the surface temperature also increases to the level of the measuring medium temperature.

Note

The maximum permissible measuring medium temperature depends on the liner and flange material, and is limited by the operating values in the following tables.

Measuring medium temperature as a function of liner and flange material

Model FEP631, FEP632; FEW631, FEW632		Measuring medium temperature range (operating data)	
Lining material	Flange material	Minimum	Maximum
Hard rubber	Steel	-10 °C (14 °F)	85 °C (185 °F)
		-5 °C (23 °F)*	80 °C (176 °F)*
Hard rubber	Stainless steel	-15 °C (5 °F)	85 °C (185 °F)
		-5 °C (23 °F)*	80 °C (176 °F)*
Soft rubber	Steel	-10 °C (14 °F)	60 °C (140 °F)
		-15 °C (5 °F)	60 °C (140 °F)
Soft rubber	Stainless steel	-10 °C (14 °F)	60 °C (140 °F)
		-15 °C (5 °F)	60 °C (140 °F)
PTFE	Steel	-10 °C (14 °F)	130 °C (266 °F)
		-25 °C (-13 °F)	130 °C (266 °F)
PTFE	Stainless steel	-10 °C (14 °F)	130 °C (266 °F)
		-25 °C (-13 °F)	130 °C (266 °F)
PFA	Steel	-10 °C (14 °F)	180 °C (356 °F)
		-25 °C (-13 °F)	180 °C (356 °F)
PFA	Stainless steel	-10 °C (14 °F)	180 °C (356 °F)
		-25 °C (-13 °F)	180 °C (356 °F)
Thick PTFE	Steel	-10 °C (14 °F)	180 °C (356 °F)
		-25 °C (-13 °F)	180 °C (356 °F)
Thick PTFE	Stainless steel	-10 °C (14 °F)	180 °C (356 °F)
		-25 °C (-13 °F)	180 °C (356 °F)
ETFE	Steel	-10 °C (14 °F)	130 °C (266 °F)
		-25 °C (-13 °F)	130 °C (266 °F)
ETFE	Stainless steel	-10 °C (14 °F)	130 °C (266 °F)
		-25 °C (-13 °F)	130 °C (266 °F)

* Only for China production site

Note

ProcessMaster FEW631 + FEW632 is available with hard rubber only.

Model FEH631, FEH632			Fluid temperature (operating values)	
Liner	Process connection	Material	Minimum	Maximum
PFA	Flange	Stainless steel	-25 °C (-13 °F)	180 °C (356 °F)
PFA	Wafer type	—	-25 °C (-13 °F)	130 °C (266 °F)
PFA	Variable process connection	Stainless steel	-25 °C (-13 °F)	130 °C (266 °F)

Measuring medium temperature (Ex Data) for ProcessMaster Model FEP631

Single-compartment housing



Dual-compartment housing



Nominal diameter	Design	Temperature class	Ambient temperature (-40 °C)* -20 °C to +40 °C	Ambient temperature (-40 °C)* -20 °C to +50 °C	Ambient temperature (-40 °C)* -20 °C to +60 °C	
			thermally uninsulated, thermally insulated	thermally uninsulated, thermally insulated	thermally uninsulated, thermally insulated	
			Gas & dust	Gas & dust	Gas & dust	
DN3 to 2000	NT	T1	130°C	130°C	130°C	
	HT		180°C	180°C	180°C	
	NT	T2	130°C	130°C	130°C	
	HT		180°C	180°C	180°C	
	NT	T3	130°C	130°C	130°C	
	HT		180°C	180°C	180°C	
	NT	T4	130°C	130°C	130°C	
	HT		130°C	130°C	130°C	
	Note: The data below does not apply to Flowmeters equipped with the plug-in card for Ethernet communication (model code DR6)!					
	NT	T5	95°C	95°C	40°C**	
	HT		95°C	95°C	—***	
	NT	T6	80°C	—	—	
	HT		80°C	—	—	

* Low-temperature version (option)

** Single-compartment housing

*** Dual-compartment housing

NT standard version, T_{medium} maximum 130 °C (266 °F)

HT high-temperature version, T_{medium} maximum 180 °C (356 °F)

Thermally uninsulated: the sensor is not enclosed with pipe insulation material.

Thermally insulated: the sensor is enclosed with pipe insulation material.

Note

Cables for power supply, signal inputs and outputs must meet the following specifications:

With single-compartment housing

- At an ambient temperature of 50 °C the cable must be suited for at least 80 °C
- At an ambient temperature of 60 °C the cable must be suited for at least 90 °C

With dual-compartment housing

- At an ambient temperature of 50 °C the cable must be suited for at least 70 °C
- At an ambient temperature of 60 °C the cable must be suited for at least 80 °C

... 8 Operation in Zone 2, 22

... Temperature data

Measuring medium temperature (Ex Data) for ProcessMaster Model FEP632



Nominal diameter	Design	Temperature class	Ambient temperature (-40 °C)* -20 °C to +40 °C	Ambient temperature (-40 °C)* -20 °C to +50 °C	Ambient temperature (-40 °C)* -20 °C to +60 °C
			thermally uninsulated, thermally insulated	thermally uninsulated, thermally insulated	thermally uninsulated, thermally insulated
			Gas & dust	Gas & dust	Gas & dust
DN3 to 2000	NT	T1	130 °C	130 °C	130 °C
	HT		180 °C	180 °C	180 °C
	NT	T2	130 °C	130 °C	130 °C
	HT		180 °C	180 °C	180 °C
	NT	T3	130 °C	130 °C	130 °C
	HT		180 °C	180 °C	180 °C
	NT	T4	130 °C	130 °C	130 °C
	HT		130 °C	130 °C	130 °C
	NT	T5	95 °C	95 °C	95 °C
	HT		95 °C	95 °C	95 °C
	NT	T6	80 °C	80 °C	40 °C
	HT		80 °C	80 °C	20 °C

* Low-temperature version (option)

NT standard version, T_{medium} maximum 130 °C (266 °F)

HT high-temperature version, T_{medium} maximum 180 °C (356 °F)

Thermally uninsulated: the sensor is not enclosed with pipe insulation material.

Thermally insulated: the sensor is enclosed with pipe insulation material.

Note

Cables for power supply, signal inputs and outputs must meet the following specifications:

- At an ambient temperature ≤ 50 °C the cable must be suited for at least 70 °C
- At an ambient temperature ≤ 60 °C the cable must be suited for at least 80 °C

Measuring medium temperature (Ex Data) for ProcessMaster Model FEW631

Single-compartment housing

Dual-compartment housing



Nominal diameter	Design	Temperature class	Ambient temperature -20 °C to +40 °C	Ambient temperature -20 °C to +50 °C	Ambient temperature -20 °C to +60 °C	
			thermally uninsulated, thermally insulated	thermally uninsulated, thermally insulated	thermally uninsulated, thermally insulated	
			Gas & dust	Gas & dust	Gas & dust	
DN25 to 3000	NT	T1	80 °C (176 °F)*	80 °C (176 °F)*	80 °C (176 °F)*	
	NT	T2	80 °C (176 °F)*	80 °C (176 °F)*	80 °C (176 °F)*	
	NT	T3	80 °C (176 °F)*	80 °C (176 °F)*	80 °C (176 °F)*	
	NT	T4	80 °C (176 °F)*	80 °C (176 °F)*	80 °C (176 °F)*	
	Note: The data below does not apply to Flowmeters equipped with the plug-in card for Ethernet communication (model code DR6)!					
	NT	T5	80 °C (176 °F)*	80 °C (176 °F)*	40°C** —***	
	NT	T6	80 °C (176 °F)	—	—	

* The limiting Factor for the measuring medium temperature is the Sensor liner material. It is limited to 80 °C (176 °F)

** Single-compartment housing

*** Dual-compartment housing

NT standard version, T_{medium} maximum 80 °C (176 °F)

Thermally uninsulated: the sensor is not enclosed with pipe insulation material.

Thermally insulated: the sensor is enclosed with pipe insulation material.

Note

Cables for power supply, signal inputs and outputs must meet the following specifications:

With single-compartment housing

- At an ambient temperature of 50 °C the cable must be suited for at least 80 °C
- At an ambient temperature of 60 °C the cable must be suited for at least 90 °C

With dual-compartment housing

- At an ambient temperature of 50 °C the cable must be suited for at least 70 °C
- At an ambient temperature of 60 °C the cable must be suited for at least 80 °C

... 8 Operation in Zone 2, 22

... Temperature data

Measuring medium temperature (Ex Data) for ProcessMaster FEW632



Nominal diameter	Design	Temperature class	Ambient temperature -20 °C to +40 °C	Ambient temperature -20 °C to +50 °C	Ambient temperature -20 °C to +60 °C
			thermally uninsulated, thermally insulated	thermally uninsulated, thermally insulated	thermally uninsulated, thermally insulated
			Gas & dust	Gas & dust	Gas & dust
DN25 to 2000	NT	T1	80 °C (176 °F)*	80 °C (176 °F)*	80 °C (176 °F)*
	NT	T2	80 °C (176 °F)*	80 °C (176 °F)*	80 °C (176 °F)*
	NT	T3	80 °C (176 °F)*	80 °C (176 °F)*	80 °C (176 °F)*
	NT	T4	80 °C (176 °F)*	80 °C (176 °F)*	80 °C (176 °F)*
	NT	T5	80 °C (176 °F)*	80 °C (176 °F)*	80 °C (176 °F)*
	NT	T6	80 °C (176 °F)	80 °C (176 °F)	40 °C (104 °F)

* The limiting Factor for the measuring medium temperature is the Sensor liner material. It is limited to 80 °C (176 °F)

NT standard version, T_{medium} maximum 80 °C (176 °F)

Thermally uninsulated: the sensor is not enclosed with pipe insulation material.

Thermally insulated: the sensor is enclosed with pipe insulation material.

Note

Cables for power supply, signal inputs and outputs must meet the following specifications:

- At an ambient temperature ≤ 50 °C the cable must be suited for at least 70 °C
- At an ambient temperature ≤ 60 °C the cable must be suited for at least 80 °C

Measuring medium temperature (Ex Data) for HygienicMaster Model FEH631

Dual-compartment housing



Single-compartment housing



Nominal diameter	Design	Temperature class	Ambient temperature (-40 °C)* -20 °C to +40 °C	Ambient temperature (-40 °C)* -20 °C to +50 °C	Ambient temperature (-40 °C)* -20 °C to +60 °C	
			thermally uninsulated, thermally insulated	thermally uninsulated, thermally insulated	thermally uninsulated, thermally insulated	
			Gas & dust	Gas & dust	Gas & dust	
DN3 to 2000	NT	T1	130 °C	130 °C	130 °C	
	HT		180 °C	180 °C	180 °C	
	NT	T2	130 °C	130 °C	130 °C	
	HT		180 °C	180 °C	180 °C	
	NT	T3	130 °C	130 °C	130 °C	
	HT		180 °C	180 °C	180 °C	
	NT	T4	130 °C	130 °C	130 °C	
	HT		130 °C	130 °C	130 °C	
	Note: The data below does not apply to Flowmeters equipped with the plug-in card for Ethernet communication (model code DR6)!					
		NT	T5	95 °C	95 °C	40 °C**
		HT		95 °C	95 °C	—***
		NT	T6	80 °C	—	—
		HT		80 °C	—	—

* Low-temperature version (option)

** Single-compartment housing

*** Dual-compartment housing

NT standard version, T_{medium} maximum 130 °C (266 °F)

HT high-temperature version, T_{medium} maximum 180 °C (356 °F)

Thermally uninsulated: the sensor is not enclosed with pipe insulation material.

Thermally insulated: the sensor is enclosed with pipe insulation material.

Note

Cables for power supply, signal inputs and outputs must meet the following specifications:

With single-compartment housing

- At an ambient temperature of 50 °C the cable must be suited for at least 80 °C
- At an ambient temperature of 60 °C the cable must be suited for at least 90 °C

With dual-compartment housing

- At an ambient temperature of 50 °C the cable must be suited for at least 70 °C
- At an ambient temperature of 60 °C the cable must be suited for at least 80 °C

... 8 Operation in Zone 2, 22

... Temperature data

Measuring medium temperature (Ex Data) for HygienicMaster Model FEH632

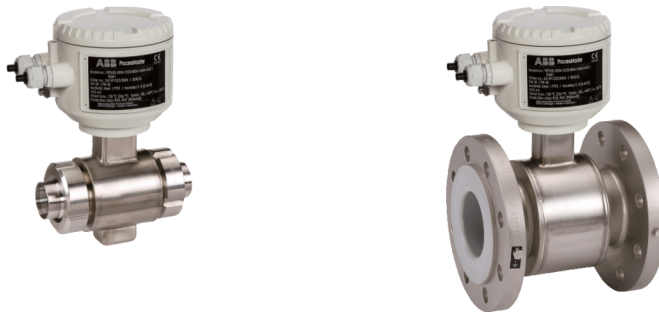

Nominal diameter	Design	Temperature class	Ambient temperature (-40 °C)* -20 °C to +40 °C	Ambient temperature (-40 °C)* -20 °C to +50 °C	Ambient temperature (-40 °C)* -20 °C to +60 °C
			thermally uninsulated, thermally insulated	thermally uninsulated, thermally insulated	thermally uninsulated, thermally insulated
			Gas & dust	Gas & dust	Gas & dust
DN3 to 2000	NT	T1	130°C	130°C	130°C
	HT		180°C	180°C	180°C
	NT	T2	130°C	130°C	130°C
	HT		180°C	180°C	180°C
	NT	T3	130°C	130°C	130°C
	HT		180°C	180°C	180°C
	NT	T4	130°C	130°C	130°C
	HT		130°C	130°C	130°C
	NT	T5	95°C	95°C	95°C
	HT		95°C	95°C	95°C
	NT	T6	80°C	80°C	40°C
	HT		80°C	80°C	20°C

* Low-temperature version (option)

NT standard version, T_{medium} maximum 130 °C (266 °F)

HT high-temperature version, T_{medium} maximum 180 °C (356 °F)

Thermally uninsulated: the sensor is not enclosed with pipe insulation material.

Thermally insulated: the sensor is enclosed with pipe insulation material.

Note

Cables for power supply, signal inputs and outputs must meet the following specifications:

- At an ambient temperature ≤ 50 °C the cable must be suited for at least 70 °C
- At an ambient temperature ≤ 60 °C the cable must be suited for at least 80 °C

9 Commissioning

Checks before commissioning

The following items must be checked before commissioning:

- The power supply must be switched off.
- The power supply used must match the information on the name plate.
- The connection assignment must be set up in accordance with the electrical connection.
- Sensor and transmitter must be grounded properly.
- The temperature limit values must be observed.
- The transmitter must be installed at a location largely free of vibrations.
- The housing cover and cover lock must be sealed before powering-up the power supply.
- For devices with a remote mount design and a measuring accuracy of 0.2 % of the measured value, make sure that the sensor and the transmitter have been correctly assigned.
- For this purpose, the final characters X1, X2, etc. are printed on the name plates of the sensors. The final characters Y1, Y2, etc. are printed on the transmitters.
- Devices with final characters X1 / Y1 or X2 / Y2 belong together.
- Any unused glands should be sealed in accordance with IEC 60079 prior to commissioning using the plugs supplied. Also refer to Cable glands

Note

Commissioning and operation should be performed in accordance with ATEX 137 or BetrSichV - German Industrial Safety Regulation (EN60079-14). Only properly trained personnel are authorized to carry out commissioning in Ex areas.

Output configuration for NAMUR switching amplifier

Configuring the current output

Current output terminals 31 / 32 / Uco can be operated on-site in active or passive mode through appropriate switching.

Terminal Uco / 32	Current output 4 to 20 mA- / HART output, active
Terminal 31 / 32	Current output 4 to 20 mA- / HART output, passive

Configuring the digital outputs

In the case of the device version suited for operation in Ex Zone 1 (dual-compartment housing), digital outputs DO1 (41 / 42) and DO2 (51 / 52) can be configured for connection to a NAMUR switching amplifier.

On leaving the factory, the device is configured with the standard wiring (non-NAMUR).

Note

The outputs' type of protection remains unaffected by this. The devices connected to these outputs must conform to the applicable regulations for explosion protection.

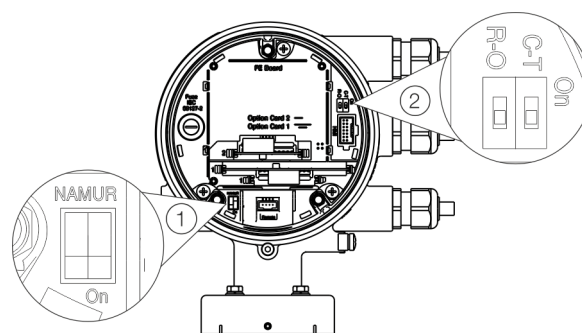

① NAMUR DIP switch ② Write protection DIP switch

Figure 17: Position of the DIP switches

Configuration of digital outputs 41 / 42 and 51 / 52

The configuration (NAMUR, optoelectronic coupler) for the digital outputs on the basic device is set via DIP switches in the transmitter.

Position	Function
On	Digital output 41 / 42 and 51 / 52 as NAMUR output.
Off	Digital output 41 / 42 and 51 / 52 as optoelectronic coupler output.

... 9 Commissioning

... Output configuration for NAMUR switching amplifier

Configuration of digital outputs V1 / V2 or V3 / V4

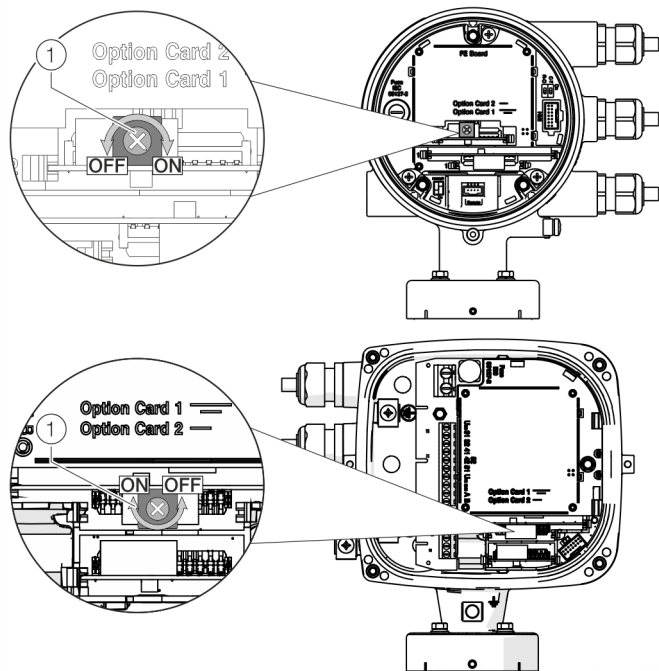

① NAMUR rotary switch

Figure 18: Position of rotary switch on the plug-in card

The configuration (NAMUR, optoelectronic coupler) for the digital output on the plug-in card is set via a rotary switch on the plug-in card.

Position	Function
On	Digital output V1 / V2 or V3 / V4 as NAMUR output.
Off	Digital output V1 / V2 or V3 / V4 as optoelectronic coupler output.

Configure the digital outputs as described:

1. Switch off the supply power and wait at least 20 minutes before the next step.
2. Loosen the cover lock, open the housing cover and move the switch to the desired position.
3. Close the housing cover lock by unscrewing the screw.

10 Maintenance

Safety instructions

WARNING

Risk of injury due to live parts!

When the housing is open, contact protection is not provided and EMC protection is limited.

- Before opening the housing, switch off the power supply.

WARNING

Loss of Ex-approval!

Loss of Ex approval due to replacement of components in devices for use in potentially explosive atmospheres.

- Devices for use in potentially explosive atmospheres may be serviced and repaired by qualified ABB personnel only.
- For measuring devices for potentially explosive atmospheres, observe the relevant operator guidelines.

CAUTION

Risk of burns due to hot measuring media

The device surface temperature may exceed 70 °C (158 °F), depending on the measuring medium temperature!

- Before starting work on the device, make sure that it has cooled sufficiently.

NOTICE

Damage to components!

The electronic components of the printed circuit board can be damaged by static electricity (observe ESD guidelines).

- Make sure that the static electricity in your body is discharged before touching electronic components.

Corrective maintenance work may only be performed by trained personnel.

- Before removing the device, depressurize it along with any adjacent lines or vessels.
- Check whether hazardous materials have been used as measuring medium before opening the device. Residual amounts of hazardous material may still be present in the device and could escape when it is opened.

Within the scope of operator responsibility, check the following as part of a regular inspection:

- pressure-carrying walls / pressure equipment liner
- the measurement-related function
- the leak tightness
- the wear (corrosion)

Sensor

The flowmeter sensor is largely maintenance-free.

The following items should be checked annually:

- Ambient conditions (air circulation, humidity).
- Tightness of the process connections.
- Cable entries, cover gaskets and cover screws.
- Operational reliability of power supply, lightning protection and grounding.

The sensor electrodes must be cleaned when the flow rate information on the transmitter changes while recording the identical flow rate volume.

If the display shows a higher flowrate, the contamination is insulating. If a lower flowrate is displayed, the contamination results in a short-circuit.

For repairs to the liner, electrodes or magnet coil, the flowmeter must be returned to the manufacturer.

Returning devices on page 60

Gaskets

Some device designs are shipped with special gaskets. These gaskets must be used and installed properly to prevent leakage and guarantee 3A and EHEDG conformity.

For all other device designs, use commercially available gaskets made from a compatible material for the measuring medium and prevailing temperature (rubber, PTFE, It, EPDM, silicon, Viton, etc.).

A wafer type sensor is installed without gaskets directly in the pipeline.

Cleaning

When cleaning the exterior of meters, make sure that the cleaning agent used does not corrode the housing surface and the seals.

To avoid static charge, a damp cloth must be used for cleaning.

11 Repair

Safety instructions

⚠ DANGER

Danger of explosion if the device is operated with the transmitter housing or terminal box open!

While using the device in potentially explosive atmospheres before opening the transmitter housing or the terminal box, note the following points:

- A valid fire permit must be present.
- Make sure that no flammable or hazardous atmospheres are present.

⚠ WARNING

Risk of injury due to live parts!

When the housing is open, contact protection is not provided and EMC protection is limited.

- Before opening the housing, switch off the power supply.

⚠ WARNING

Loss of Ex-approval!

Loss of Ex approval due to replacement of components in devices for use in potentially explosive atmospheres.

- Devices for use in potentially explosive atmospheres may be serviced and repaired by qualified ABB personnel only.
- For measuring devices for potentially explosive atmospheres, observe the relevant operator guidelines.

⚠ CAUTION

Risk of burns due to hot measuring media

The device surface temperature may exceed 70 °C (158 °F), depending on the measuring medium temperature!

- Before starting work on the device, make sure that it has cooled sufficiently.

NOTICE

Damage to components!

The electronic components of the printed circuit board can be damaged by static electricity (observe ESD guidelines).

- Make sure that the static electricity in your body is discharged before touching electronic components.

Spare parts

Repair and maintenance activities may only be performed by authorized customer service personnel.

When replacing or repairing individual components, use original spare parts.

Note

Spare parts can be ordered from ABB Service.

www.abb.com/contacts

Replacing the fuse

NOTICE

If the O-ring gasket is seated incorrectly or damaged, this may have an adverse effect on the housing protection class. Follow the instructions in **Opening and closing the housing** on page 17 to open and close the housing safely.

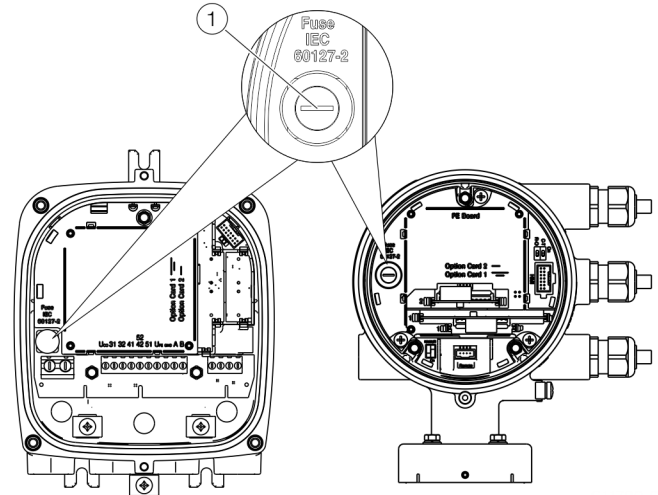

① Fuse holder

Figure 19: Fuse holder position

There is a fuse in the transmitter housing.

Power supply transmitter	11 to 30 V DC	100 to 240 V AC
Rated current of fuse	1.25 A	0.8 A
Nominal voltage of fuse	250 V AC	250 V AC
Design	Device fuse 5 x 20 mm	
Breaking capacity	1500 A at 250 V AC	
Ordering number	3KQR000757U0100	3KQR000757U0200

Perform the following steps to replace the fuse:

1. Switch off the power supply.
2. Open the transmitter housing.
3. Pull out the defective fuse and insert a new fuse.
4. Closing the transmitter housing.
5. Switch on the power supply.
6. Check that the device is working correctly.

If the fuse blows again on activation, the device is defective and must be replaced.

Replacing the LCD indicator

Dual-compartment housing

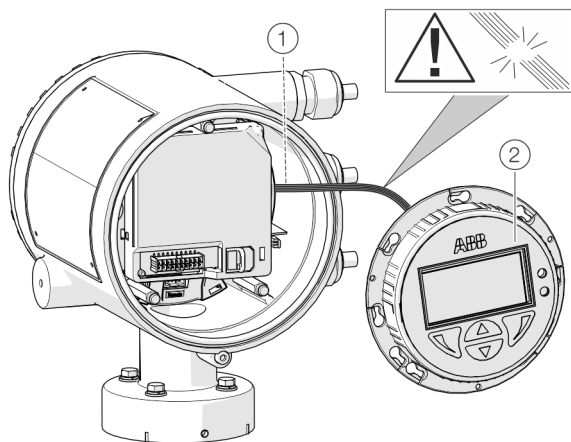

① LCD indicator cable harness

Single-compartment housing

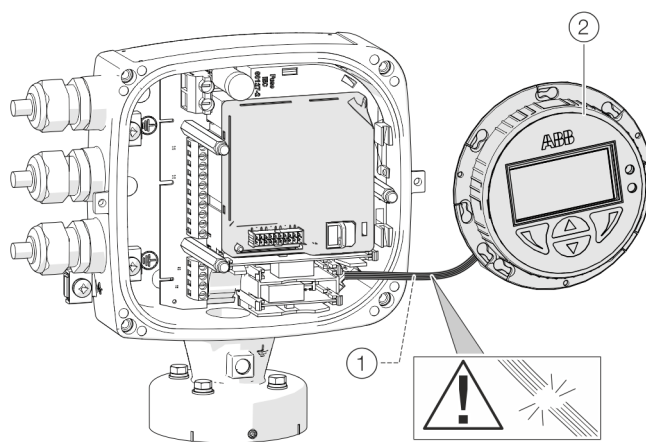

② LCD indicator

Figure 20: Replacing the LCD Indicator (example)

NOTICE

If the O-ring gasket is seated incorrectly or damaged, this may have an adverse effect on the housing protection class. Follow the instructions in **Opening and closing the housing** on page 17 to open and close the housing safely.

The LCD indicator can be replaced in the event of a malfunction.

Component	Ordering number
LCD indicator (HMI)	3KQZ407125U0100
For integral mount and remote mount design	

Replace the LCD indicator by following the steps below:

1. Switch off the power supply.
2. Unscrew / remove the cover.
3. Loosen fixing screws for LCD indicator (only in integral mount design).
4. Remove the LCD indicator.
5. Pull the connector out of the motherboard.
6. Attach the connector on the new LCD indicator. Ensure that the cable harness is not damaged.
7. Insert the LCD indicator and tighten if necessary.
8. Unscrew / set down the cover once again
9. Switch on the power supply.

... 11 Repair

Replacing the frontend board

Integral mount design

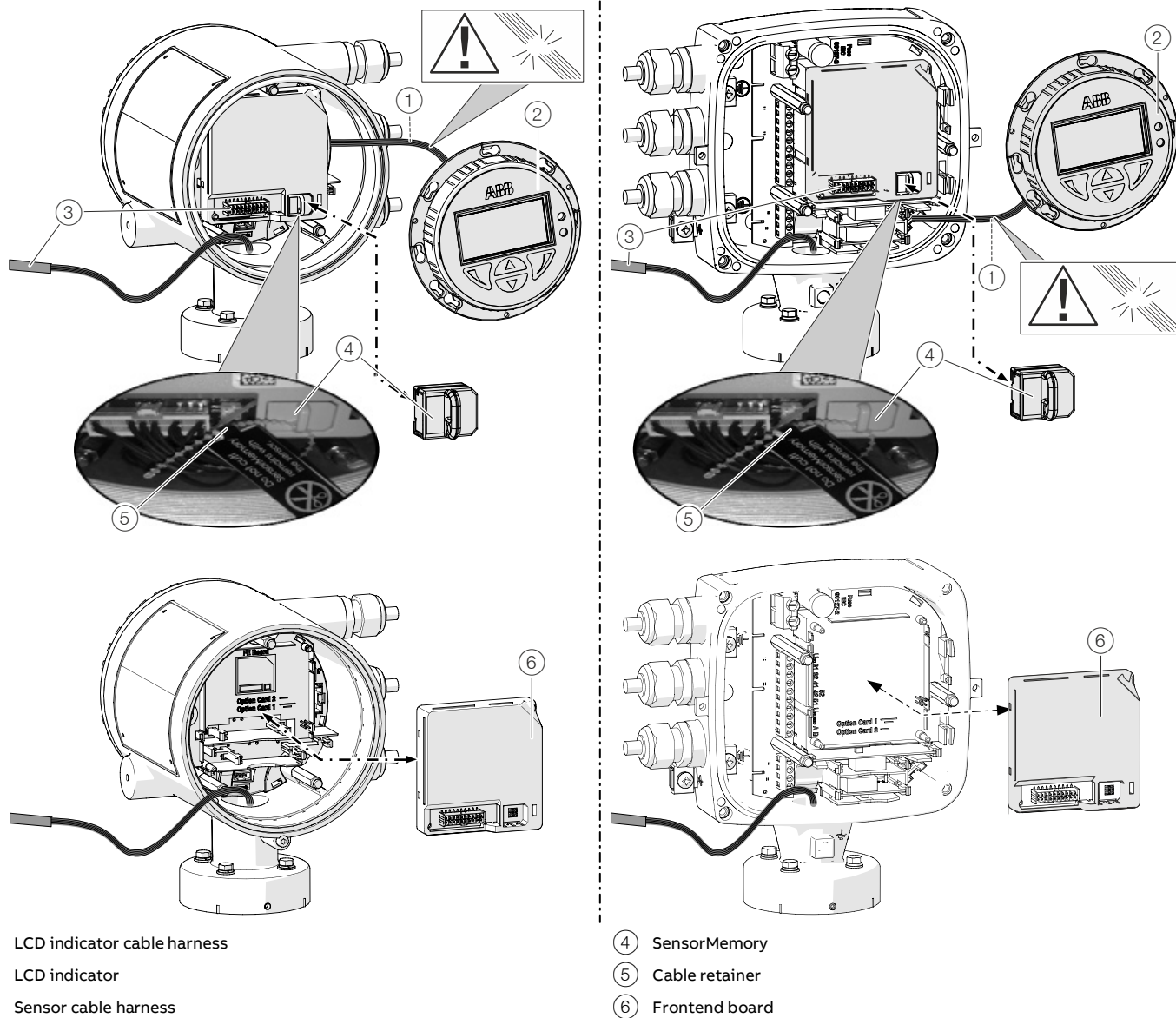

- ① LCD indicator cable harness
- ② LCD indicator
- ③ Sensor cable harness

- ④ SensorMemory
- ⑤ Cable retainer
- ⑥ Frontend board

Figure 21: Replacing LCD indicator and frontend board (example)

NOTICE

If the O-ring gasket is seated incorrectly or damaged, this may have an adverse effect on the housing protection class.

Follow the instructions in **Opening and closing the housing** on page 17 to open and close the housing safely.

In the event of a fault, the frontend board can be replaced on flowmeters with an integral mount design.

Replace the frontend board as follows:

1. Switch off the power supply.
2. Unscrew / remove the cover.
3. Remove the LCD indicator. Ensure that the cable harness is not damaged.
4. Pull the connector out of the sensor cable harness.
5. Pull out the SensorMemory.

Note

The SensorMemory is assigned to the sensor. The SensorMemory is therefore fastened to the sensor cable harness with a cable retainer.

Ensure that the SensorMemory remains with the sensor and cannot be lost!

6. Pull the faulty frontend board out forwards.
7. Insert new frontend board.
8. Attach connector from the sensor cable harness.
9. Attach the SensorMemory.
10. Insert the LCD indicator and screw on /replace the cover.
11. Once the power supply is switched on, load the system data from the SensorMemory.

... 11 Repair

... Replacing the frontend board

Remote mount design

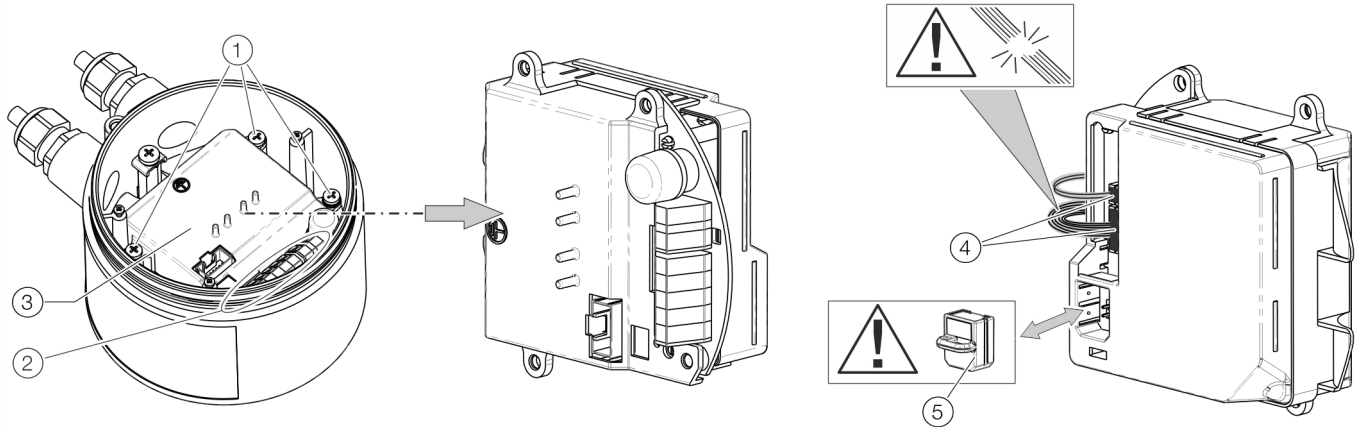

- ① Frontend board fixing screw
- ② Terminals
- ③ Frontend board

- ④ Connections for flowmeter sensor
- ⑤ SensorMemory

Figure 22: Replacing the frontend board (flowmeter sensor)

NOTICE

If the O-ring gasket is seated incorrectly or damaged, this may have an adverse effect on the housing protection class. Follow the instructions in **Opening and closing the housing** on page 17 to open and close the housing safely.

The frontend board can be replaced in the event of a malfunction.

Replace the frontend board as follows:

1. Switch off the power supply.
2. Unscrew / remove the cover.
3. Loosen the fixing screws (3×) at the frontend board.
4. Remove the faulty frontend board.
5. Pull the connector out of the sensor cable harness. Ensure that the cable harness is not damaged.
6. Pull out the SensorMemory.

Note

The SensorMemory is assigned to the sensor. Ensure that the SensorMemory remains with the sensor and cannot be lost!

7. Insert the SensorMemory into the new frontend board.
8. Connect the plug of the sensor cable harness.
9. Insert the new frontend board and secure it with the fixing screws (3×).
10. After powering up the power supply, the transmitter automatically replicates the system data from the SensorMemory.

Replacing the motherboard

Dual-compartment housing

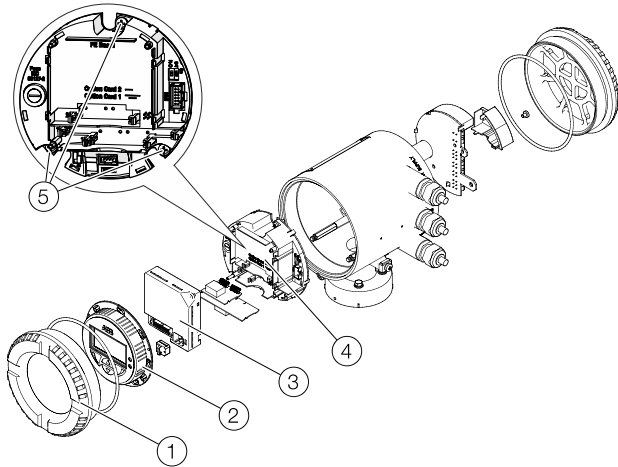

- ① Housing cover
- ② LCD indicator
- ③ Frontend board

Single-compartment housing

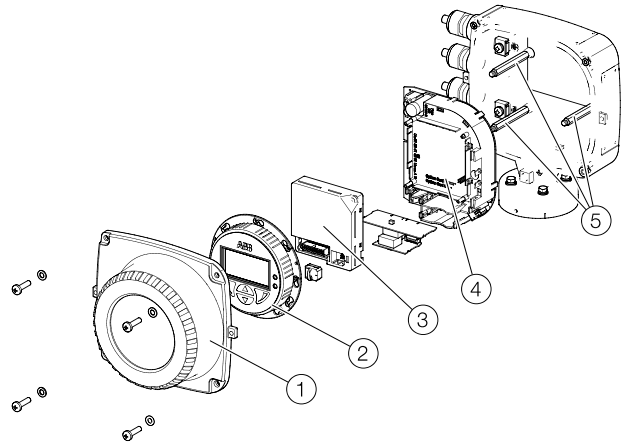

- ④ Motherboard
- ⑤ Mounting screws / bolts for motherboard

Figure 23: Replacing the Motherboard

NOTICE

If the O-ring gasket is seated incorrectly or damaged, this may have an adverse effect on the housing protection class. Follow the instructions in **Opening and closing the housing** on page 17 to open and close the housing safely.

In the event of a fault, the motherboard can be replaced.

Replace the motherboard as follows:

1. Switch off the power supply.
2. Unscrew / remove the cover ①.
3. Remove the LCD indicator ②. Ensure that the cable harness is not damaged.
4. Pull the connector out of the sensor cable harness.

5. Pull the frontend board ③ out forwards.
6. **Only on single-compartment housing:** Disconnect all signal and power supply cables.
7. Loosen the fastening screws / bolts ⑤ for the motherboard.
8. Remove the faulty motherboard.
9. Insert new motherboard.
10. Tighten the fastening screws / bolts ⑤ for the motherboard.
11. **Only on single-compartment housing:** Connect all signal and power supply cables according chapter Electrical connections in the operating instruction.
12. Attach the frontend board.
13. Attach the LCD indicator
14. screw on / replace the cover. Make sure the gasket is seated properly.
15. Switch on the power supply.

... 11 Repair

Replacing the sensor

WARNING

Risk of injury due to process conditions.

The process conditions, for example high pressures and temperatures, toxic and aggressive measuring media, can give rise to hazards when working on the device.

- Before working on the device, make sure that the process conditions do not pose any hazards.
- If necessary, wear suited personal protective equipment when working on the device.
- Depressurize and empty the device / piping, allow to cool and purge if necessary.

NOTICE

If the O-ring gasket is seated incorrectly or damaged, this may have an adverse effect on the housing protection class.

Follow the instructions in **Opening and closing the housing** on page 17 to open and close the housing safely.

Note

The frontend board of the replacement sensor has a SensorMemory module.

The calibration and system data of the sensor is stored in the SensorMemory.

After powering-up the power supply, the transmitter automatically replicates the system data from the SensorMemory.

Replace the sensor as described below:

1. Switch off the power supply.
2. Unscrew / remove the cover.
3. Disconnect the signal cable (if necessary, remove the potting compound).
4. Install the new sensor in accordance with Installation in the operating instruction.
5. Complete the electrical connection in accordance with Electrical connections in the operating instruction.
6. Unscrew / set down the cover once again
7. After powering-up the power supply, the transmitter automatically replicates the system data from the SensorMemory.

Returning devices

Use the original packaging or a secure transport container of an appropriate type if you need to return the device for repair or recalibration purposes.

Fill out the return form (see **Return form** on page 62) and include this with the device.

In accordance with the EU Directive governing hazardous materials, the owner of hazardous waste is responsible for its disposal or must observe the following regulations for shipping purposes:

All devices delivered to ABB must be free from any hazardous materials (acids, alkalis, solvents, etc.).

Address for returns

Please contact Customer Center Service acc. to page 5 for nearest service location.

12 Recycling and disposal

Dismounting

WARNING

Risk of injury due to process conditions.

The process conditions, for example high pressures and temperatures, toxic and aggressive measuring media, can give rise to hazards when dismantling the device.

- If necessary, wear suited personal protective equipment during disassembly.
- Before disassembly, make sure that the process conditions do not pose any safety risks.
- Depressurize and empty the device / piping, allow to cool and purge if necessary.

Bear the following points in mind when dismantling the device:

- Switch off the power supply.
- Disconnect electrical connections.
- Allow the device / piping to cool and depressurize and empty. Collect any escaping medium and dispose of it in accordance with environmental guidelines.
- Use suited tools to disassemble the device, taking the weight of the device into consideration.
- If the device is to be used at another location, the device should preferably be packaged in its original packing so that it cannot be damaged.
- Observe the notices in **Returning devices** on page 60.

Disposal

Note



Products that are marked with the adjacent symbol may **not** be disposed of as unsorted municipal waste (domestic waste).

They should be disposed of through separate collection of electric and electronic devices.

This product and its packaging are manufactured from materials that can be recycled by specialist recycling companies.

Bear the following points in mind when disposing of them:

- As of 8/15/2018, this product will be under the open scope of the WEEE Directive 2012/19/EU and relevant national laws (for example, ElektroG - Electrical Equipment Act - in Germany).
- The product must be supplied to a specialist recycling company. Do not use municipal waste collection points. These may be used for privately used products only in accordance with WEEE Directive 2012/19/EU.
- If there is no possibility to dispose of the old equipment properly, our Service can take care of its pick-up and disposal for a fee.

To find your local ABB service contact visit:

www.abb.com/contacts

or call +49 180 5 222 580

13 Additional documents

Note

All documentation, declarations of conformity, and certificates are available in ABB's download area.

www.abb.com/flow

Trademarks

Ethernet-APL is a trademark of the FieldComm Group, ODVA Inc., OPC Foundation and PROFIBUS Nutzerorganisation e.V.

EtherNet/IP is a trademark of ODVA Inc.

HART is a registered trademark of FieldComm Group, Austin, Texas, USA

Modbus is a registered trademark of Schneider Automation Inc.

PROFIBUS, PROFIBUS PA and PROFIBUS DP are registered trademarks of PROFIBUS & PROFINET International (PI)

14 Appendix

Return form

Statement on the contamination of devices and components

Repair and/or maintenance work will only be performed on devices and components if a statement form has been completed and submitted.

Otherwise, the device/component returned may be rejected. This statement form may only be completed and signed by authorized specialist personnel employed by the operator.

Customer details:

Company:

Address:

Contact person:

Telephone:

Fax:

Email:

Device details:

Type:

Serial no.:

Reason for the return/description of the defect:

Was this device used in conjunction with substances which pose a threat or risk to health?

Yes No

If yes, which type of contamination (please place an X next to the applicable items):

biological

corrosive / irritating

combustible (highly / extremely combustible)

toxic

explosive

other toxic substances

radioactive

Which substances have come into contact with the device?

1.

2.

3.

We hereby state that the devices/components shipped have been cleaned and are free from any dangerous or poisonous substances.

Town/city, date

Signature and company stamp

Installation diagram 3KXF000061G0009

Installation diagram FEP630_ / FEH630_ / FET630_ / FEW630_

ORDINARY LOCATION GENERAL PURPOSE	HAZARDOUS LOCATION Zone 2/21 Division 2 & ZN 2/21	HAZARDOUS LOCATION Zone 1/21 Division 1 & ZN 1/21
ATEX: - IECEX: -	ATEX: II 3 G & II 2 D IECEX: Gc & Db	ATEX: II 2/1 (1) G & II 2 (1) D II 2/1 G & II 2 D II 2 (1) G & II 2 (1) D
US: Certified for ordinary location CDN: Certified for ordinary location	US: NI / 1 / 2 / ABCD & DIP / II, III / 1 / EFG I / 2 / AEx nA & I / 21 AEx tb CDN: I / 2 / ABCD & II, III / 1 / EFG I / 2 / Ex nA & I / 21 Ex tb	IECEX: Gb/Ga (Ga) & Db (Da) Gb/Ga & Db Gb (Ga) & Db (Da) US: XP-IS / 1 / 1 / ABCD & DIP / II, III / 1 / EFG CDN: I / 1 / AEx ia mb tb & I / 21 / AEx ia ma tb XP-IS I / 1 / ABCD & DIP / II, III / 1 / EFG I / 1 / Ex ia mb tb & I / 21 / Ex ia ma tb

a

POWER SUPPLY
Non IS
Terminals
max 250Vrms

1+L2-N⊥

b

SIGNAL DATA INPUT/OUTPUT
"IS" or "ia" if installed in Zone 1 or Division 1.
In Zone 1 or Division 1 intrinsically safe supply required

3132U_{OP}V3V4V1V241425251

c

SENSOR SIGNALS
Connection between sensor and associated FET63_ transmitter

ABUPEGRN

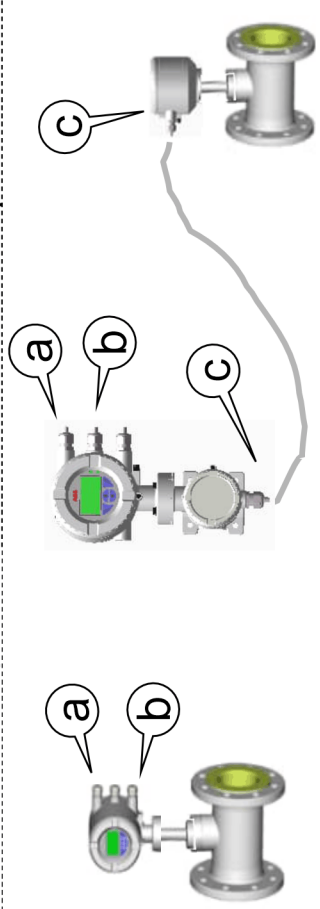

For Model: FE_630_	Projection method 1	General Tolerances: Tolerancing Surface:
ABB ABB AG	Date: 01.20.2016 Name: FBu	Installation diagram FE_630
Rev.: 08 Date: 06.06.2025 Number: FBu	Checked per: S10	Material: 3KXF000061G0009
Replicates:		

PAGE 1 OF 13

... 14Appendix

... Installation diagram 3KXF000061G0009

<p>Notes: ATEX & IECEx application</p> <ol style="list-style-type: none"> 1. THE INTRINSIC SAFETY ENTITY CONCEPT ALLOWS THE INTERCONNECTION OF TWO ATEX/IECEx APPROVED INTRINSICALLY SAFE DEVICES WITH ENTITY PARAMETERS NOT SPECIFICALLY EXAMINED IN COMBINATION AS A SYSTEM WHEN: U_o OR V_{oc} OR $V_t < V_{MAX}$; I_o OR I_{oc} OR $I_t < I_{MAX}$; C_a OR $C_o > C_i + C_{cable}$; L_a OR $L_o > L_i + L_{cable}$; $P_o < P_i$. 2. DUST-TIGHT CONDUIT SEAL MUST BE USED WHEN INSTALLED IN Zone 21/22 ENVIROMENTS. 3. CONTROL EQUIPMENT CONNECTED TO THE ASSOCIATED APPARATUS MUST NOT USE OR GENERATE MORE THAN 250 Vrms OR Vdc WITH RESPECT TO EARTH. 4. INSTALLATION SHOULD BE IN ACCORDANCE WITH THE RELEVANT INTERNATIONAL OR NATIONAL REGULATIONS "INSTALLATION OF INTRINSICALLY SAFE FOR HAZARDOUS LOCATIONS" REGULATIONS. 5. THE CONFIGURATION OF ASSOCIATED APPARATUS MUST BE ATEX or IECEx APPROVED UNDER ENTITY CONCEPT. 6. ASSOCIATED APPARATUS MANUFACTURER 'S INSTALLATION DRAWING MUST BE FOLLOWED WHEN INSTALLING THIS EQUIPMENT. 7. THE ASSOCIATED APPARATUS MUST BE INSTALLED IN ACCORDANCE WITH BARRIER MANUFACTURE 'S INSTALLATION DIAGRAM 8. SELECTED ASSOCIATED APPARATUS MUST BE THIRD PARTY LISTED AS PROVIDING INTRINSICALLY SAFE CIRCUITS FOR THE APPLICATION. IT MUST MEET THE REQUIREMENTS LISTED IN TABLE OF THIS INSTALLATION DIAGRAM: 	<p>Notes: US and Canadian application</p> <ol style="list-style-type: none"> 1. THE INTRINSIC SAFETY ENTITY CONCEPT ALLOWS THE INTERCONNECTION OF TWO FM AND/OR CSA APPROVED INTRINSICALLY SAFE DEVICES WITH ENTITY PARAMETERS NOT SPECIFICALLY EXAMINED IN COMBINATION AS A SYSTEM WHEN: U_o OR V_{oc} OR $V_t < V_{MAX}$; I_o OR I_{oc} OR $I_t < I_{MAX}$; C_a OR $C_o > C_i + C_{cable}$; L_a OR $L_o > L_i + L_{cable}$; $P_o < P_i$. 2. DUST-TIGHT CONDUIT SEAL MUST BE USED WHEN INSTALLED IN CLASS II AND III ENVIROMENTS. 3. CONTROL EQUIPMENT CONNECTED TO THE ASSOCIATED APPARATUS MUST NOT USE OR GENERATE MORE THAN 250 Vrms OR Vdc WITH RESPECT TO EARTH. 4. INSTALLATION FOR U.S. AND CANADIAN APPROVED EQUIPMENT SHOULD BE IN ACCORDANCE WITH ANSI/ISA RP12.6 „INSTALLATION OF INTRINSICALLY SAFE SYSTEMS FOR HAZARDOUS (CLASSIFIED) LOCATIONS“. THE NATIONAL ELECTRICAL CODE (ANSI/NFPA 70) SECTIONS 504, 505 AND THE CANADIAN ELECTRICAL CODE (C22.1-02). 5. THE CONFIGURATION OF ASSOCIATED APPARATUS MUST BE FM AND/OR CSA APPROVED UNDER ENTITY CONCEPT. 6. ASSOCIATED APPARATUS MANUFACTURER 'S INSTALLATION DRAWING MUST BE FOLLOWED WHEN INSTALLING THIS EQUIPMENT. 7. THE ASSOCIATED APPARATUS MUST BE INSTALLED IN ACCORDANCE WITH BARRIER MANUFACTURE 'S INSTALLATION DIAGRAM 8. SELECTED ASSOCIATED APPARATUS MUST BE THIRD PARTY LISTED AS PROVIDING INTRINSICALLY SAFE CIRCUITS FOR THE APPLICATION. IT MUST MEET THE REQUIREMENTS LISTED IN TABLE OF THIS INSTALLATION DIAGRAM:
<p>Dieses ist eine zertifizierte Zeichnung Änderungen nur mit Zustimmung der Prüfstelle THIS IS A CERTIFIED DRAWING REVISIONS ONLY WITH APPROVAL OF THE NOTIFIED BODY</p>	<p>Rev. Date Number Name Replicated: 08 06.06.2025 FBu</p>
<p>Projection method 1  Date Name 01.20.12.2016 FBu</p>	<p>General tolerances: Work, piece edges: Installation diagram FE_630 3KXF000061G0009</p>
<p>Tolerance: Surface: Tolerance: Surface: Tolerance: Surface:</p>	

We reserve all rights for this document. Without our previous agreement this document may not be reproduced or made available to third parties or utilized in any other manner. Violators will be subject to penalties and may be punishable by law.

Zone 2/21 & Division 2

Model code
FEa63dY0
FEa63dA2
FEa63dF2

HART Modbus Profibus DP PA Ethernet Communication

Indication	Abbr.	Status	Option	Terminal	Operating Value				
					U _{nom} [V]	I _{nom} [mA]	Exec./Exc./NI I _{nom} [mA]		
		Active or Passive	Chosen Option depending on Model Number (MN)	If "or" occurs Terminal depends on MN	GP	U _{nom} [V]	I _{nom} [mA]	Exec./Exc./NI I _{nom} [mA]	
On board									
Current Output 1	CO1	A	On board Power Supply	31/U _{Co}		30	30	30	
Current Output 2	CO2	P		31/32		30	30	30	
Digital Output 1	DO1	A	With OC Active Supply	41/42 and V1/V2		30	30	30	
Digital Output 2	DO2	A	With OC Active Supply	51/52 and V1/V2		30	30	30	
Digital Output 3	DO3	P		51/52		30	30	30	
Option Cards (OC)									
Current Output 2	CO2	A	With OC Active Supply	V1/V2 and V3/V4		30	30	30	
Current Output 3	CO3	P		V1/V2 or V3/V4		30	30	30	
Digital Output 3	DO3	A	With OC Active Supply	V1/V2 and V3/V4		30	30	30	
Digital Input 1	DI1	A	With OC Active Supply	V1/V2 and V3/V4		30	3,45	3,45	
Modbus / Profibus DP	---	A		V1/V2		30	30	30	
Profibus PA	---	A		V1/V2		32	30	30	
Ethernet Modul Power over Ethernet PoE	---	A		X1...X8		57	417	417	
Ethernet APL	---	A		---		57	417	417	
Advance Physical Layer		P		V1/V2		17,5	380	17,5 380	

Dieses ist eine zertifizierte Zeichnung
Änderungen nur mit Zustimmung der Prüfstelle
THIS IS A CERTIFIED DRAWING
REVISIONS ONLY WITH APPROVAL OF THE NOTIFIED BODY

We reserve all rights for this document. Without our previous agreement this document may not be reproduced or made available in print or other media. Violations will be subject to penalties and may be punishable by law.

For Model	FE_630_	Projection method 1	ABB ABB AG	General tolerances: Work piece edges:
Rev.	Date	Number	Name	Tolerancing: Surface:
08	06.06.2025	FBu	FBu	
Installation diagram FE_630				
				3KXF000061G0009
				NET-BPM

Allowed I/O connections and OPTION CARD handling:

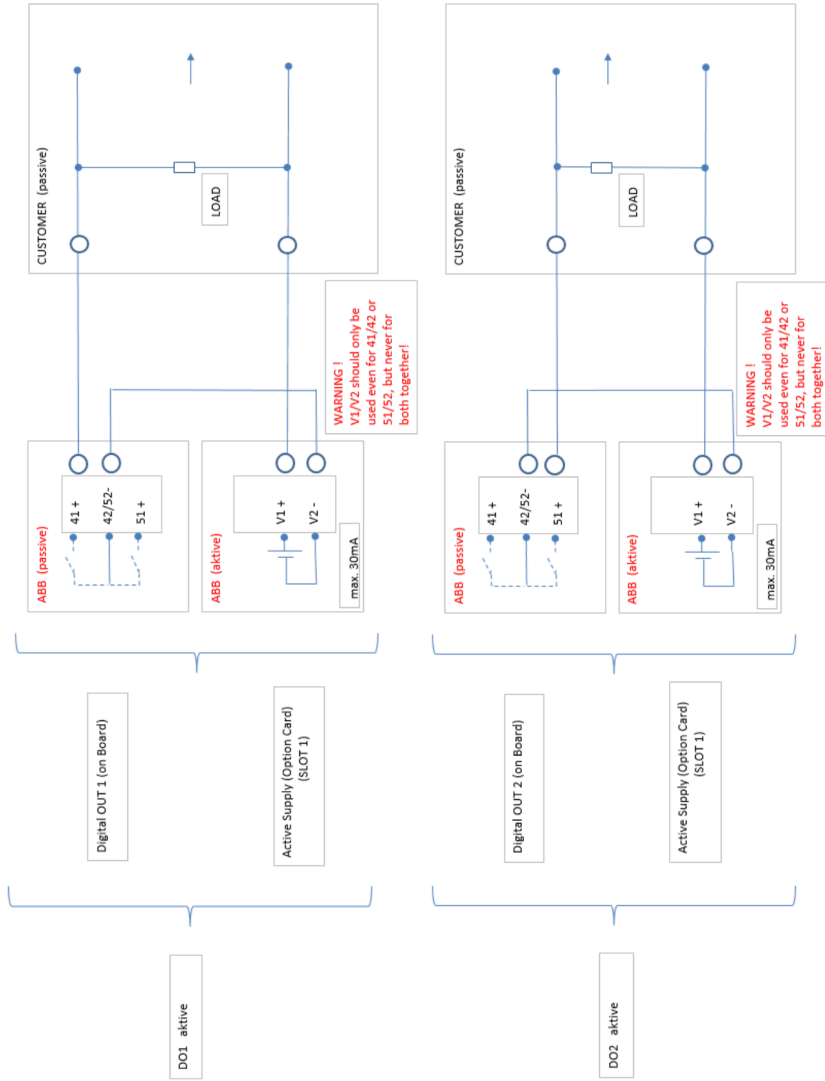

Dieses ist eine zertifizierte Zeichnung
 Änderungen nur mit Zustimmung der Prüfstelle
 THIS IS A CERTIFIED DRAWING
 REVISIONS ONLY WITH APPROVAL OF THE NOTIFIED BODY

We reserve all rights for this document. Without our previous agreement this document may not be reproduced or made available to third parties or utilized in any other manner. Violations will be subject to penalties and may be punishable by law.

For Model: FE_630_	Projection method 1	General Tolerances: Work piece edges:	Tolerancing: Surface:
	ABB ABB AG		
	Date: 01.20.2016 Name: FBu	Installation diagram FE_630	
Rev.: 08.06.2025	Number: FBu	3KXF000061G0009	
Date: 08.06.2025	Name: FBu	Material: 3KXF000061G0009	
Checked per: 516	Checked per: 516	Material: 3KXF000061G0009	
Approved by: 516	Approved by: 516	Material: 3KXF000061G0009	
Rev.:	Date:	Number:	Name:

... 14Appendix

... Installation diagram 3KXF000061G0009

Allowed I/O connections and OPTION CARD handling:

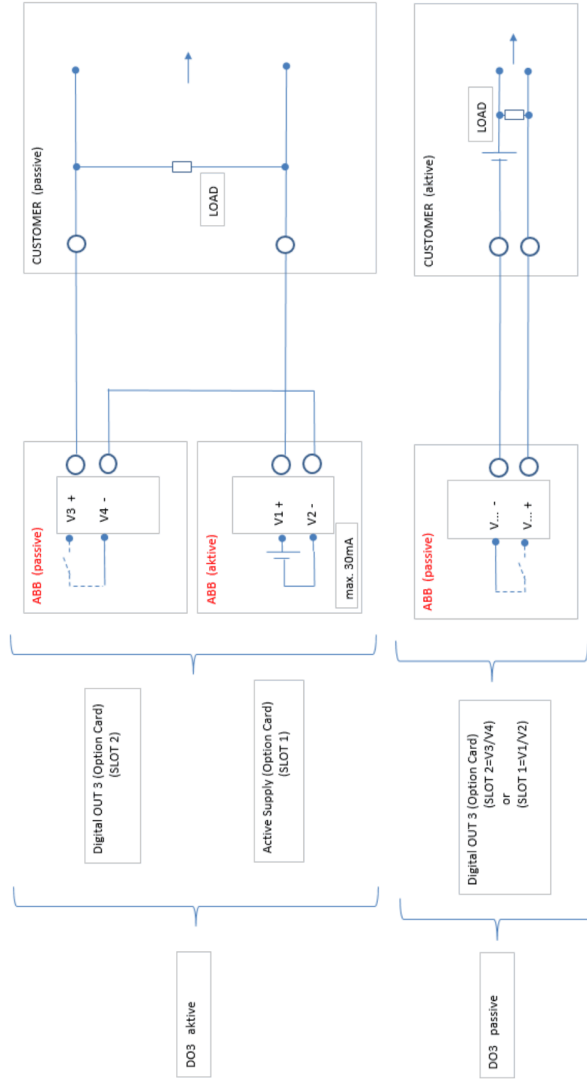

Dieses ist eine zertifizierte Zeichnung
 Änderungen nur mit Zustimmung der Prüfstelle
 THIS IS A CERTIFIED DRAWING
 REVISIONS ONLY WITH APPROVAL OF THE NOTIFIED BODY

We reserve all rights for this document. Without our previous agreement this document may not be reproduced or made available to third parties or utilized in any other manner. Violations will be subject to penalties and may be punishable by law.

For Model: FE_630_	Projection method 1	General Tolerances: Work piece edges:	Tolerancing Surface:
	ABB ABB AG		
	Date: 01.20.2016 Name: FBu	Installation diagram FE_630	
08.06.2025	08.06.2025	3KXF000061G0009	
Rev. Date Number Name	FBu		

Allowed I/O connections and OPTION CARD handling:

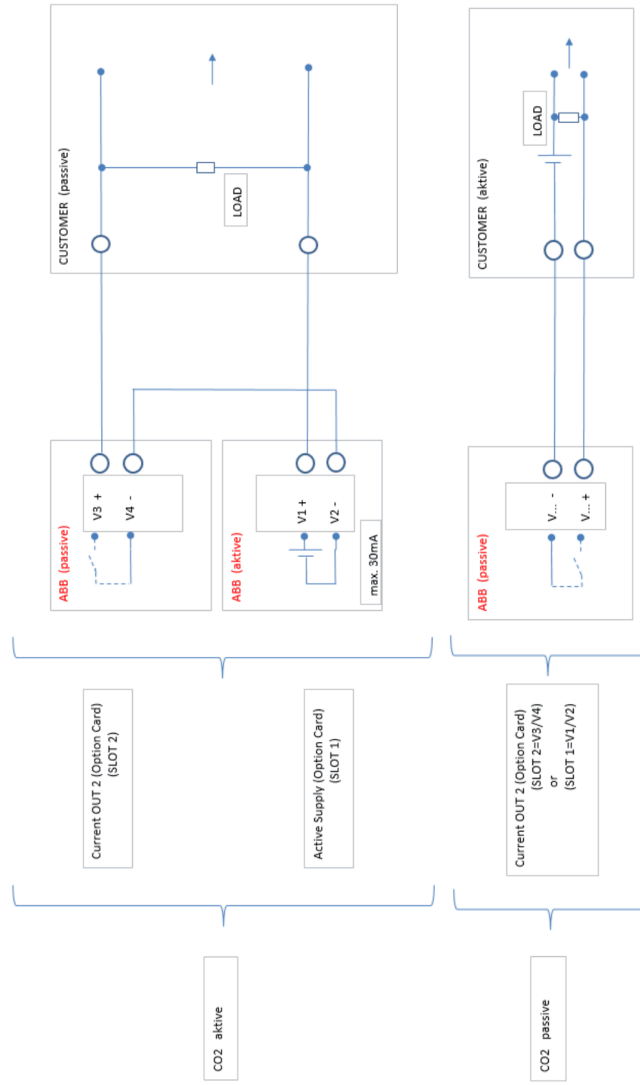

Dieses ist eine zertifizierte Zeichnung
 Änderungen nur mit Zustimmung der Prüfstelle
 THIS IS A CERTIFIED DRAWING
 REVISIONS ONLY WITH APPROVAL OF THE NOTIFIED BODY

We reserve all rights for this document. Without our previous agreement this document may not be reproduced or made available to third parties or utilized in any other manner. Violations will be subject to penalties and may be punishable by law.

For Model: FE_630_	Projection method 1	General Tolerances: Work, piece edges:	Tolerancing: Surface:
	ABB ABB AG		
	Date: 01.20.2016 Name: FBu	Installation diagram FE_630	
08.06.2025	08.06.2025	3KXF000061G0009	
Rev. Date Number Name	Rev. Date Number Name	Rev. Date Number Name	Rev. Date Number Name

... 14Appendix

... Installation diagram 3KXF000061G0009

Allowed I/O connections and OPTION CARD handling:

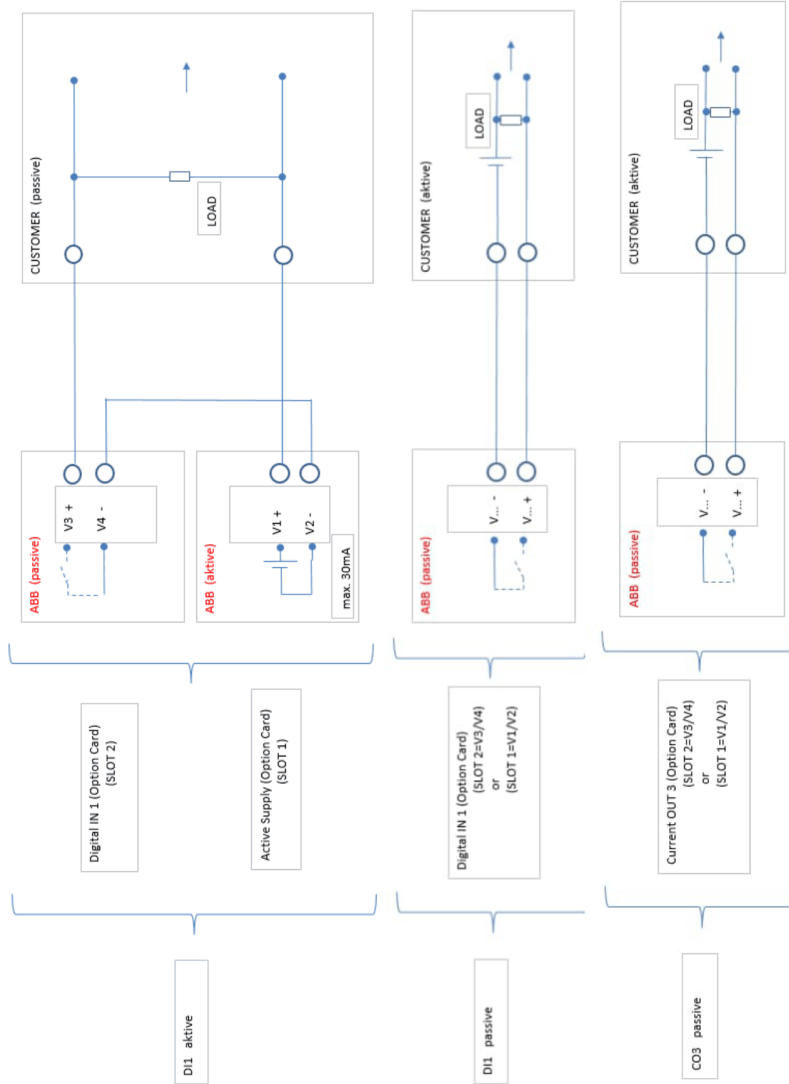

Dieses ist eine zertifizierte Zeichnung
 Änderungen nur mit Zustimmung der Prüfstelle
 THIS IS A CERTIFIED DRAWING
 REVISIONS ONLY WITH APPROVAL OF THE NOTIFIED BODY

We reserve all rights for this document. Without our previous
 agreement this document may not be reproduced or made available to
 third parties or utilized in any other manner. Violations will be subject
 to penalties and may be punishable by law.

For Model	FE_630_	Projection method 1	General Tolerances: Work, piece edges:	Tolerancing Surface:
		Installation diagram		
		FE_630		
Rev.	Date	Number	Name	REPLACES:
08	06.06.2025	FBu		
Checked per 516	01.20.12.2016	FBu	Name	
Drawn by				
3KXF000061G0009				

Allowed I/O connections and OPTION CARD handling:

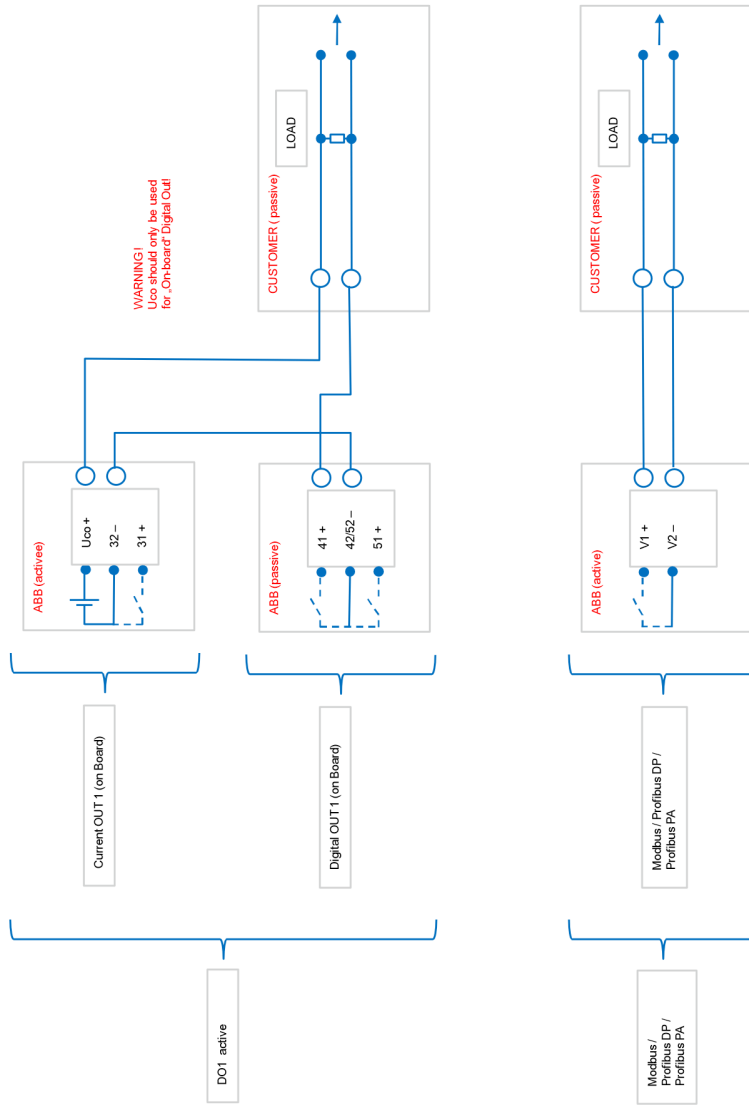

Dieses ist eine zertifizierte Zeichnung
Änderungen nur mit Zustimmung der Prüfstelle
THIS IS A CERTIFIED DRAWING
REVISIONS ONLY WITH APPROVAL OF THE NOTIFIED BODY

We reserve all rights for this document. Without our previous agreement this document may not be reproduced or made available to third parties or utilized in any other manner. Violations will be subject to penalties and may be punishable by law.

For Model: FE_630_	Projection method 1	General tolerances: Work piece edges:	Tolerancing: Surface:
	ABB ABB AG		
	Date: 01.20.12.2016 Name: FBu	Installation diagram FE_630	
Rev.: 08.06.2025	Number: FBu	3KXF000061G0009	
	Name: FBu		

... 14Appendix

... Installation diagram 3KXF000061G0009

Allowed I/O connections and OPTION CARD handling:

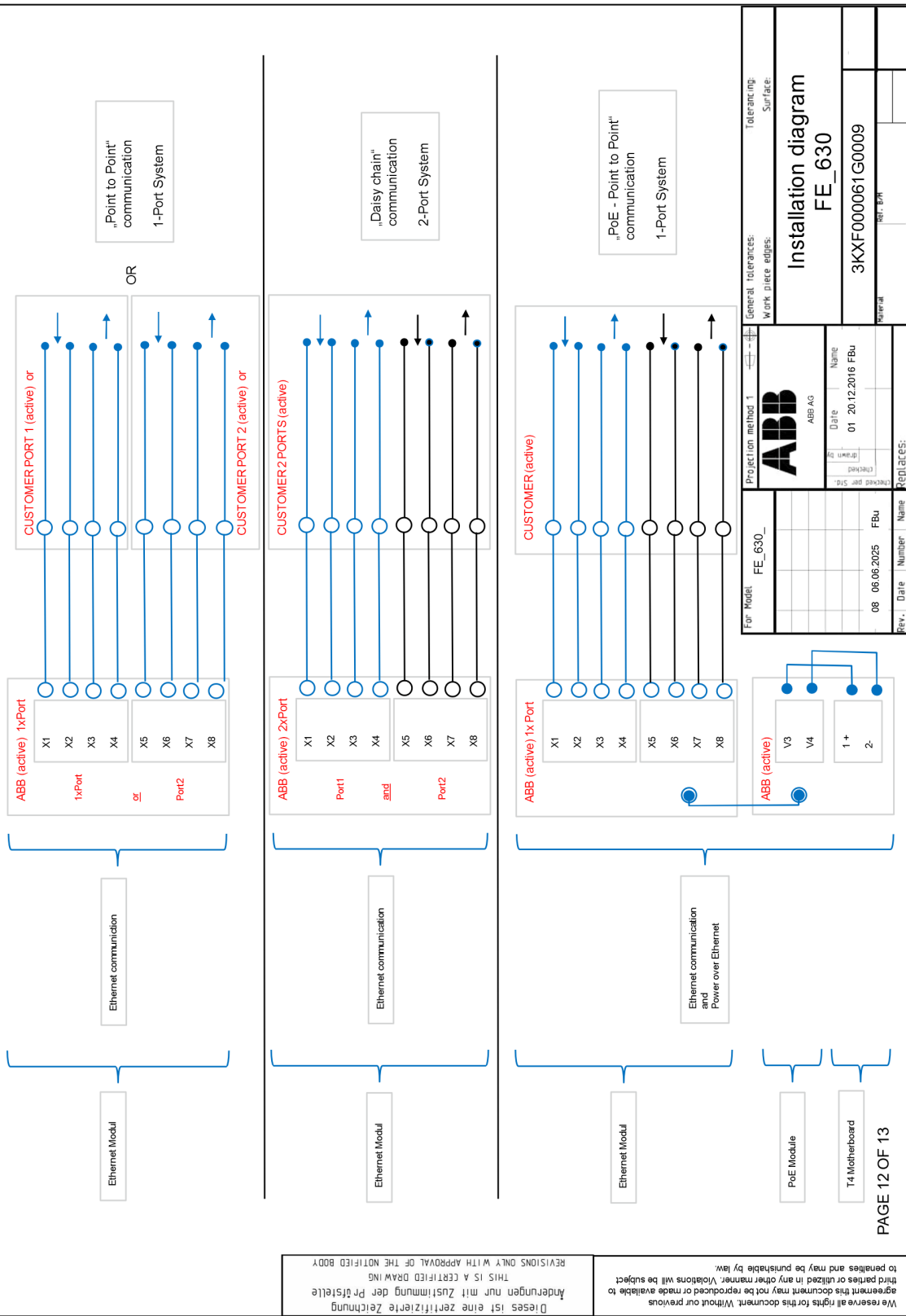

Dieses ist eine zertifizierte Zeichnung
 Änderungen nur mit Zustimmung der Prüfstelle
 THIS IS A CERTIFIED DRAWING
 REVISIONS ONLY WITH APPROVAL OF THE NOTIFIED BODY

Ihr Name: _____
 Name: _____
 Datum: 01.20.2016
 Date: 01.20.2016
 Projekt: 3KXF000061G0009
 Project: 3KXF000061G0009

ABB
 ABB AG
 Projection method 1
 General Tolerances:
 Work piece edges:
 Tolerancing Surface:
 Installation diagram
 FE_630
 3KXF000061G0009

Rev. Date Number Name
 08 06.06.2025 FBu
 Checked per 515
 Rep. Date: _____
 Name: _____

Allowed I/O connections and OPTION CARD handling:

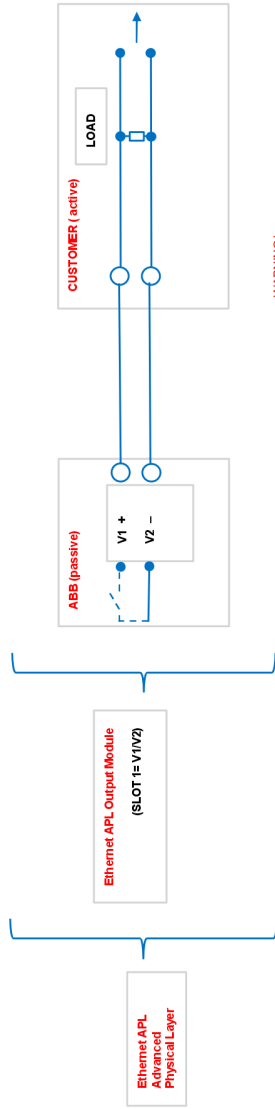

WARNING!
 APL- Module: permitted combination with
 other IO Module listed in instruction manual.

Dieses ist eine zertifizierte Zeichnung
 Änderungen nur mit Zustimmung der Prüfstelle
 THIS IS A CERTIFIED DRAWING
 REVISIONS ONLY WITH APPROVAL OF THE NOTIFIED BODY

We reserve all rights for this document. Without our previous
 agreement this document may not be reproduced or made available to
 third parties or utilized in any other manner. Violations will be subject
 to penalties and may be punishable by law.

For Model	FE_630_	Projection method 1	General Tolerances:	Tolerancing
			Work piece edges:	Surface:
		ABB ABB AG		
		Date	Installation diagram	
		01 20.12.2016	FE_630	
		Name	3KXF000061G0009	
		Checked per 510	Material	
		Checked per 510	Material	
Rev.	Date	Number	Name	
08	06.06.2025	FBU	FBU	
PAGE 13 OF 13				



ABB Measurement & Analytics

For your local ABB contact, visit:
www.abb.com/contacts

For more product information, visit:
www.abb.com/flow

We reserve the right to make technical changes or modify the contents of this document without prior notice. With regard to purchase orders, the agreed particulars shall prevail.
ABB does not accept any responsibility whatsoever for potential errors or possible lack of information in this document.

We reserve all rights in this document and in the subject matter and illustrations contained therein. Any reproduction, disclosure to third parties or utilization of its contents – in whole or in parts – is forbidden without prior written consent of ABB.