

FSM4000

Electromagnetic flowmeter



Valid for software versions C.10 and higher

Measurement made easy

—
FSM4000-SE41F
FSM4000-SE21
FSM4000-S4

Introduction

The FSM4000 is a robust flowmeter for high process requirements. It masters critical applications and conserves valuable resources with highly accurate measurement of process parameters in a wide range of sectors.

The design of the flowmeter allows for a wide range of sector-specific liner materials, electrodes and nominal diameters in accordance with respective needs. The high-performance transmitter is easy to use and offers a highly stable signal output. Maximum measuring accuracy in applications with high cellulose or high solids content, pulsating flows and other applications with disruptions.

Additional Information

Additional documentation on FSM4000 is available for download free of charge at www.abb.com/flow. Alternatively simply scan this code:



Table of contents

1 Safety	4	Torque information	20
General information and instructions	4	Flange and wafer type devices, model SE41F / SE21W	20
Warnings	4	Variable process connections model SE21	23
Intended use	5	Measuring range table	24
Improper use	5	Grounding	25
Warranty provisions	5	General information on grounding	25
Cyber security disclaimer	6	Metal pipe with fixed flanges	25
Software downloads	6	Metal pipe with loose flanges	26
Manufacturer's address	6	Non-metallic pipes or pipes with insulating liner	26
Customer service center	6	Ground for devices with protection plates	27
2 Design and function	7	Grounding with conductive PTFE grounding plate	27
Overview	7	6 Electrical connections	27
Measuring principle	9	Safety instructions	27
Design	9	Preparing and routing the signal and magnetic coil cable	28
Device designs	9	Preparing for sensor model SE21	28
3 Product identification	10	Preparing for sensor model SE41F	29
Position of the name plate / factory plate	10	Routing the signal and magnetic coil cable	30
Identification of the device design	10	Connecting the sensor	31
Name plate	10	Connecting the signal and magnet coil cables	31
Sensor	10	Connection with IP rating IP 68	32
Transmitter	10	Connecting the transmitter	33
Factory tag	11	Connecting the power supply	33
4 Transport and storage	12	Connecting the signal and magnet coil cables	34
Inspection	12	Terminal assignment	35
Transport	12	Standard DN 3 to DN 1000 (1/10 to 40")	35
Flange devices ≤ DN 450	12	With preamplifier DN 3 to DN 1000 (1/10 to 40")	36
Flange devices > DN 450	12	Retrofit for model 10DI1422: DN 3 to DN 1000 (1/10 to 40"); model 10DI1425 and 10DS3111A-E: DN 500 to DN 1000 (20 to 40")	37
Storing the device	13	Digital communication	38
Temperature data	13	HART® protocol	38
Storage temperature	13	Connection examples for peripherals (incl. HART)	38
Returning devices	13	Current output	38
5 Installation	14	Switch output	38
Safety instructions	14	Switch input	39
Installation conditions	14	Pulse output	39
General	14	7 Commissioning	40
Brackets	15	Safety instructions	40
Gaskets	15	Checks before commissioning	40
Flow direction	15	Commissioning	41
Electrode axis	15	Power Supply Power-Up	41
Mounting position	16	Device configuration	42
Grounding	16	Easy Set-up, for uncomplicated parameterization	43
Sensor insulation	16		
Inlet and outlet sections	17		
Free inlet or outlet	17		
Mounting with heavily contaminated measuring media	17		
Mounting with pipe vibration	18		
Installation in piping with larger nominal diameter	18		
Installing the sensor	19		

8	Operation	44	13	Specification.....	109
	Safety instructions	44		Measuring accuracy.....	109
	Display options	44		Reference conditions in accordance with EN 29104..	109
	Data entry	45		Maximum measuring error.....	109
	Initiating the ENTER function when using the magnet			Analog output effects.....	109
	stick for operation.....	45		Sensor SE41F.....	109
	Entering data in short form.....	46		Temperature graph.....	109
	Parameter descriptions.....	47		Max. permissible cleaning temperature	
	Additional information regarding use of enhanced			PTFE-, PFA-design	109
	diagnostic functions.....	82		Min. permissible pressure as a function of measuring	
	Recommended settings for diagnosis limit values....	86		medium temperature.....	110
	Displaying the diagnostic values	88		Sensor material	110
	Readjusting the coil temperature.....	91		Process connection material.....	110
	Software history	92		Storage temperature	111
	For transmitters without communication or HART			IP rating in accordance with EN 60529	111
	protocol.....	92		Pipe vibration according to EN 60068-2-6	111
	S4 operation with older sensor	93		Designs.....	111
				Material loads for process connections.....	111
9	Diagnosis / error messages	96		Sensor SE21_	115
	Overview of error states and alarms.....	96		Minimum permissible absolute pressure	115
	Error messages during operation and with data entry...97			Maximum permissible cleaning temperature.....	115
	Warning messages during operation.....	99		Maximum Allowable Temperature Shock	115
				Maximum permissible ambient temperature as a	
				function of measuring medium temperature	115
10	Maintenance / Repair	101		Sensor material	115
	Safety instructions	101		Process connection material.....	115
	Sensor	101		Storage temperature	115
	Gaskets	101		IP rating in accordance with EN 60529	115
	Replacing the transmitter.....	102		Pipe vibration according to EN 60068-2-6	115
	Returning devices	103		Material loads for process connections.....	116
				Transmitter	116
11	Recycling and disposal.....	104	14	Additional documents	117
	Dismounting.....	104			
	Disposal	104			
12	Spare parts list	105	15	Appendix	118
	Fuses for transmitter electronics.....	105		Overview of setting parameters and technical design .	118
	Spare parts for transmitter S4	106		Return form	119
	Field mount housing	106			
	Spare parts for sensor.....	107			
	Terminal box stainless steel DN 3 to DN 100.....	107			
	Terminal box, aluminum DN 3 to DN 1000.....	108			

1 Safety

General information and instructions

These instructions are an important part of the product and must be retained for future reference.

Installation, commissioning, and maintenance of the product may only be performed by trained specialist personnel who have been authorized by the plant operator accordingly. The specialist personnel must have read and understood the manual and must comply with its instructions.

For additional information or if specific problems occur that are not discussed in these instructions, contact the manufacturer. The content of these instructions is neither part of nor an amendment to any previous or existing agreement, promise or legal relationship.

Modifications and repairs to the product may only be performed if expressly permitted by these instructions.

Information and symbols on the product must be observed.

These may not be removed and must be fully legible at all times.

The operating company must strictly observe the applicable national regulations relating to the installation, function testing, repair and maintenance of electrical products.

Warnings

The warnings in these instructions are structured as follows:

DANGER

The signal word '**DANGER**' indicates an imminent danger. Failure to observe this information will result in death or severe injury.

WARNING

The signal word '**WARNING**' indicates an imminent danger. Failure to observe this information may result in death or severe injury.

CAUTION

The signal word '**CAUTION**' indicates an imminent danger. Failure to observe this information may result in minor or moderate injury.

NOTICE

The signal word '**NOTICE**' indicates possible material damage.

Note

'**Note**' indicates useful or important information about the product.

Intended use

This device is intended for the following uses:

- For the transmission of fluid, pulpy or pasty measuring media with electrical conductivity.
- For volume flow measurement (in operating conditions).
- For mass flow measurement (based on a non-adjustable density value).

The device has been designed for use exclusively within the technical limit values indicated on the identification plate and in the data sheets.

When using measuring media, the following points must be observed:

- Wetted parts such as measuring electrodes, liner, grounding electrodes, grounding plates or protection plates must not be damaged by the chemical and physical properties of the measuring medium during the operating time.
- Measuring media with unknown properties or abrasive measuring media may only be used if the operator is able to perform regular and suitable tests to ensure the safe condition of the device
- The indications on the name plate must be observed
- Before use of corrosive or abrasive measuring media, the operator must clarify the level of resistance of wetted parts.

ABB will gladly support you in the selection, but cannot accept any liability in doing so.

Improper use

The following are considered to be instances of especially improper use of the device:

- Operation as a flexible compensating adapter in piping, for example for compensating pipe offsets, pipe vibrations, pipe expansions, etc.
- For use as a climbing aid, for example for mounting purposes.
- For use as a bracket for external loads, for example as a support for piping, etc.
- Material application, for example by painting over the housing, name plate or welding/soldering on parts.
- Material removal, for example by spot drilling the housing.

Warranty provisions

Using the device in a manner that does not fall within the scope of its intended use, disregarding this manual, using underqualified personnel, or making unauthorized alterations releases the manufacturer from liability for any resulting damage. This renders the manufacturer's warranty null and void.

... 1 Safety

Cyber security disclaimer

This product is designed to be connected to and to communicate information and data via a network interface. It is operator's sole responsibility to provide and continuously ensure a secure connection between the product and your network or any other network (as the case may be). Operator shall establish and maintain any appropriate measures (such as but not limited to the installation of firewalls, application of authentication measures, encryption of data, installation of anti-virus programs, etc.) to protect the product, the network, its system and the interface against any kind of security breaches, unauthorized access, interference, intrusion, leakage and/or theft of data or information. ABB and its affiliates are not liable for damages and/or losses related to such security breaches, any unauthorized access, interference, intrusion, leakage and/or theft of data or information.

On www.abb.com/cybersecurity under 'Additional resources', 'Alerts and notifications' you will find notifications about newly discovered software vulnerabilities. It is recommended that you visit this website regularly and activate 'Subscribe to email alerts' to receive email notifications about 'ABB cyber security alerts and notifications'.

Software downloads

By visiting the web page indicated below, you will find options to download the latest software. It is recommended that you visit this web page regularly:

[ABB Library - FSM4000](#)



Manufacturer's address

ABB Limited
Measurement & Analytics
Oldends Lane, Stonehouse
Gloucestershire, GL10 3TA
UK
Tel: +44 (0)1453 826661
Fax: +44 (0)1453 829671
Email: instrumentation@gb.abb.com

ABB Engineering (Shanghai) Ltd.
Measurement & Analytics
No. 4528, Kangxin Highway, Pudong New District
Shanghai, 201319,
P.R. China
Tel: +86(0) 21 6105 6666
Fax: +86(0) 21 6105 6677
Email: china.instrumentation@cn.abb.com

Customer service center

Customer service center
Tel: +49 180 5 222 580
Email: automation.service@de.abb.com

2 Design and function

Overview

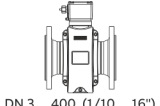
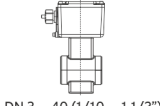
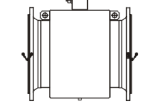
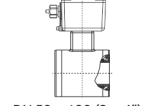
Housing material	Alu. Housing, Series 4000		Stainless Steel Housing, Series 2000	
	 DN 3 ... 400 (1/10 ... 16")		 DN 3 ... 40 (1/10 ... 1 1/2")	
	 DN 450 ... 1000 (18 ... 40")		 DN 50 ... 100 (2 ... 4")	
	Fixed Flange		Wafer type	
Sensor				
Model number	SE41F		SE21W	
Measured error	0.5% of rate (> DN 2)			
	DN	PN	DN	PN
Wafer type	—		3 to 50 65 to 100	10 to 40 10 to 16
Flange DIN 2501/EN 1092-1	3 to 1000	10 to 40	—	—
Flange ASME B16.5/B16.47	1/10 to 40"	CL 150	—	—
JIS B2210-10K	1/10 to 12"	CL 300	—	—
Liner	Hard/soft rubber, ceramic carbide, PTFE, PFA, ETFE, other		PFA (vacuum-tight)	
Conductivity	≥ 20 μS/cm (optional ≥ 5/0.5 μS/cm)			
Electrodes	Stainless steel 1.4571 (316 Ti), 1.4539 (904 L), Hastelloy B-3/C-4, platinum-iridium, tantalum, titanium			
Process connection material	Steel, stainless steel		—	
IP degree of protection in accordance with EN 60529	IP 65 / IP 67 / IP 68		IP 65 / IP 67 / IP 68	
Measuring medium temperature	-25 to 130 °C / 180 °C (-13 to 266 °F / 356 °F)		-40 to 130 °C (-40 to 266 °F)	
Approvals				
Model number	SE41F		SE21W	
Pressure Equipment Directive 97/23/EC	Conformity assessment in accordance with category III, fluid group 1			
CRN (Canadian Reg. Number)	On request			

... 2 Design and function

... Overview

Transmitter

Model number	S4
Power supply	85 to 253 V AC, 24 V AC/DC
Current output	0/2 to 10 mA, 0/4 to 20 mA
Pulse output	active (24 V), optocoupler (220 mA)
Ext. output switch-off	yes
Ext. totalizer reset	yes
Forward / reverse flow measurement	yes
Communication	HART® protocol
Pipe empty detection std.	yes, DN 10 or higher and $\geq 20 \mu\text{S}/\text{cm}$
Self-monitoring, extended diagnosis functions	yes, extended diagnostic functions / fingerprint only in connection with sensors SE21 and SE41F for DN 10 or higher
Local display / totalization	yes
Density correction	yes, manual entry (totalize and display in mass units)
IP rating in accordance with EN 60529	IP 65 / IP 67, NEMA 4X
Chassis	Field mount housing

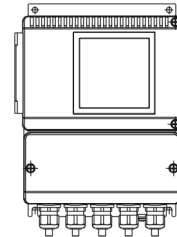

Measuring principle

Measurements performed by the electromagnetic flowmeter are based on Faraday's law of induction. A voltage is generated in a conductor when it moves through a magnetic field.

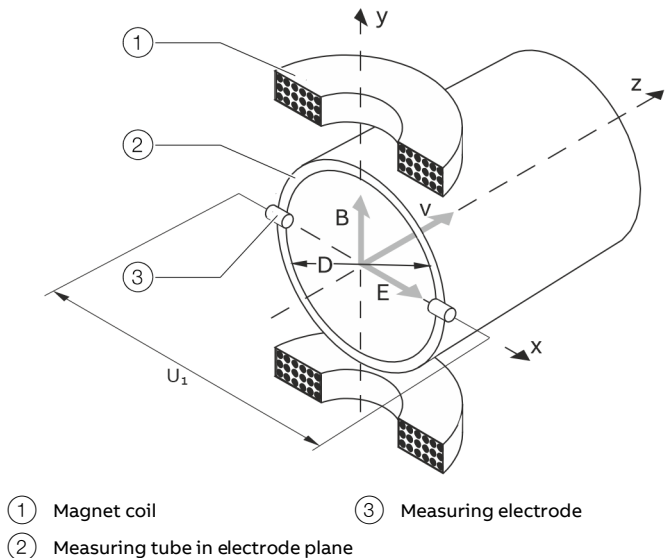

Figure 1: Electromagnetic flowmeter diagram

$U_1 \sim B \times D \times v$	$qv = \frac{D^2 \times \pi}{4} \times v$	$U_1 \sim qv$
U_1 Measuring span	v Average flow velocity	
B Magnetic induction	qv Volume flow rate	
D Electrode spacing		

With the device-relevant application of this measuring principle, a conductive measuring medium flows through a tube in which a magnetic field is generated perpendicular to the flow direction (see Figure 1).

The voltage induced in the measuring medium is tapped by two diametrically opposed electrodes. This measurement voltage is proportional to the magnetic induction, the electrode spacing and the average medium velocity v .

Taking into account that the magnetic induction and the electrode spacing are constant values results in a proportion between the measurement voltage U_1 and the average medium velocity.

From the calculation of the volume flow rate follows that the measurement voltage is linear and proportional to the volume flow rate.

The induced voltage is converted by the transmitter to standardized, analog and digital signals.

Design

An electromagnetic flowmeter system consists of a flowmeter sensor and a transmitter. The flowmeter sensor (model SE41F, SE21W) is installed in the specified pipeline while the transmitter (S4) is mounted locally or at a central location.

Device designs

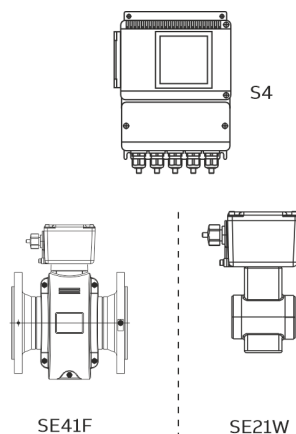

Figure 2: Device designs

The μP transmitter is mounted at a separate location from the sensor. Up to 50 m signal cable length for a minimum conductivity of 20 $\mu S/cm$. For sensors with preamplifiers, the signal cable length is increased to 200 m. The electrical connection between the transmitter and the sensor primary is provided by a signal cable and a magnetic coil cable in the terminal box.

The transmitter is available in the design:

- Field mount housing model S4

The flowmeter sensor comes with aluminum or stainless steel housing:

- Aluminum housing: model FSM4000-SE41F
- Stainless steel housing: model FSM4000-SE21W

Note

Older model flowmeter sensors can be connected to S4 transmitters. For additional information, see **Checks before commissioning** on page 40 or **S4 operation with older sensor** on page 93.

3 Product identification

Position of the name plate / factory plate

The factory tag or name plate can be found in the following places on the meter housing:

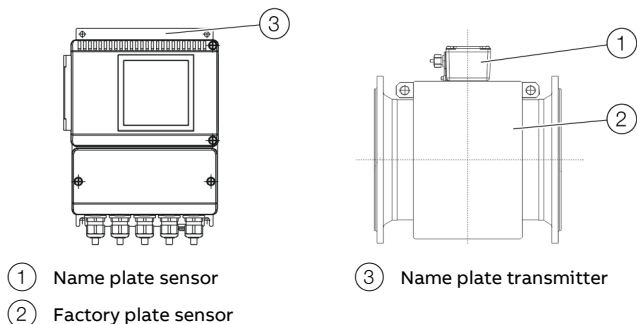

Figure 3: Plate positions

Identification of the device design

- Identifying the model:
The model number of the flowmeter primary or transmitter (see nos. 1 or 2 in the description of the model plates) can be found on the model plate. The electrical connection for the respective model can be found in the chapter 'Electrical connections'. Technical data, material load curves, etc., appear sorted by model in the chapter 'Specification'.
- Identifying the transmitter design:
The transmitter design can be identified from the name plate on the transmitter housing.
- Identifying the software version:
The software version can be displayed when the transmitter is switched on.

Note



Products that are marked with the adjacent symbol may **not** be disposed of as unsorted municipal waste (domestic waste). They should be disposed of through separate collection of electric and electronic devices.

Name plate

Note

The name plates displayed are examples. The device identification plates affixed to the device can differ from this representation.

Sensor

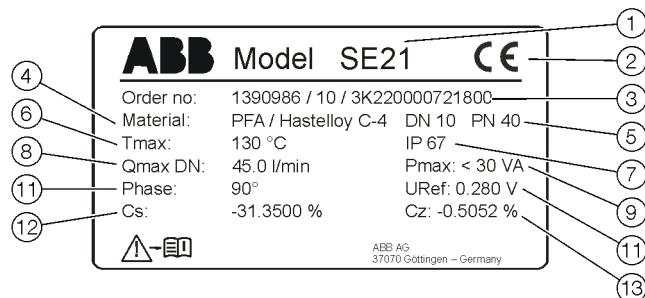

- | | |
|--|---|
| 1 Model no. | 8 Max. flow rate at v = 10 m/s |
| 2 CE mark (EG conformity) | 9 Power consumption |
| 3 Order number | 10 Phase relationship between signal and reference voltages |
| 4 Meter tube lining / electrode material | 11 Reference voltage |
| 5 Nominal diameter / Nominal pressure | 12 Cs calibration factor span |
| 6 Max. measuring medium temperature | 13 Cz calibration factor zero point |
| 7 IP rating of the housing | |

Figure 4: Name plate sensor

Transmitter

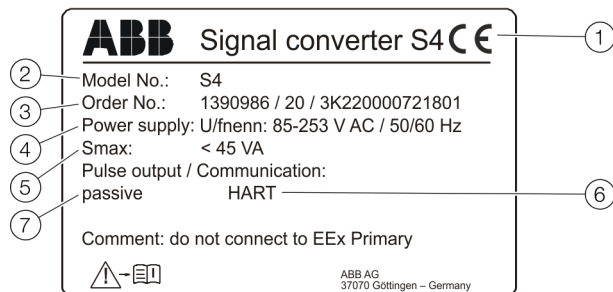

- | | |
|--|--|
| 1 CE mark (EG conformity) | 6 Design according to order with/without HART® protocol |
| 2 Model no. | 7 Design according to order active (24 V pulse) or passive (optoelectronic coupler) (Switch to active or passive) can be made on site) |
| 3 Order number | |
| 4 Power supply - voltage range / frequency | |
| 5 Power consumption transmitter and sensor | |

Figure 5: Name plate transmitter S4

Factory tag

The factory plate is on the flowmeter in addition to the name plate. Depending on the nominal diameter of the flowmeter (> DN 25 or ≤ DN 25), it is identified with two different factory plates (also refer to article 4, paragraph 3, Pressure Equipment Directive 2014/68/EU):

Pressure equipment in the scope of the Pressure Equipment Directive

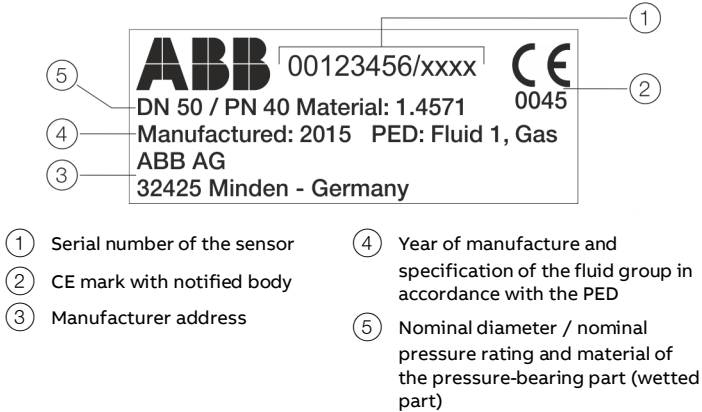

Figure 6: Factory plate for nominal diameter > DN 25 (example)

The number of the notified body is specified underneath the CE mark to confirm that the device meets the requirements of the Pressure Equipment Directive.

The respective fluid group in accordance with the Pressure Equipment Directive is indicated under PED.

Example: Fluid Group 1 = hazardous fluids, gaseous.

Pressure equipment outside the scope of the Pressure Equipment Directive

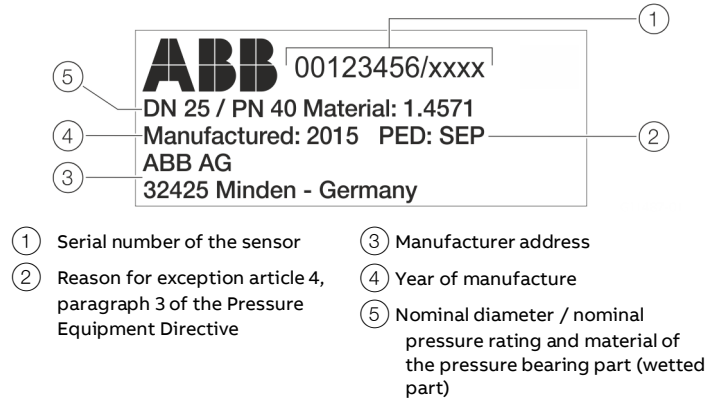

Figure 7: Factory plate for nominal diameter ≤ DN 25 (example)

In PED the exception to article 4 paragraph 3 of the Pressure Equipment Directive is specified.

The pressure equipment is classified in the SEP (= Sound Engineering Practice) 'Good Engineering Practice' category.

Note

If the factory plate is missing all together, the device is not in compliance with the requirements of the Pressure Equipment Directive 2014/68/EU. Networks for the supply, distribution and discharge of water and related specific accessories are classed as an exception in accordance with guideline 1/16 of Art. 1, Para. 3.2 of the Pressure Equipment Directive.

4 Transport and storage

Inspection

Check the devices immediately after unpacking for possible damage that may have occurred from improper transport. Details of any damage that has occurred in transit must be recorded on the transport documents.

All claims for damages must be submitted to the shipper without delay and before installation.

Transport

⚠ DANGER

Life-threatening danger due to suspended loads.

In the case of suspended loads, a danger of the load falling exists.

- Standing under suspended loads is prohibited.

⚠ WARNING

Risk of injury due to device slipping.

The device's center of gravity may be higher than the harness suspension points.

- Make sure that the device does not slip or turn during transport.
- Support the device laterally during transport.

NOTICE

Potential damage to the device!

The protection plates or protection caps mounted at the process connections on devices with PTFE / PFA liners may only be removed immediately before installation.

- To prevent possible leakage, make sure that the liner on the flange is not cut or damaged.

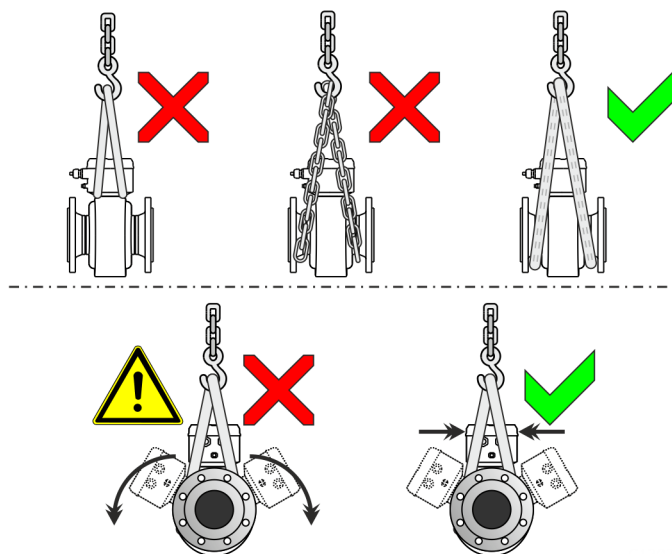

Figure 8: Transport instructions - ≤ DN 450

Flange devices ≤ DN 450

- Use carrying straps to transport flange designs smaller than DN 450.
- Wrap the carrying straps around both process connections when lifting the device.
- Chains should not be used, since these may damage the housing.

Flange devices > DN 450

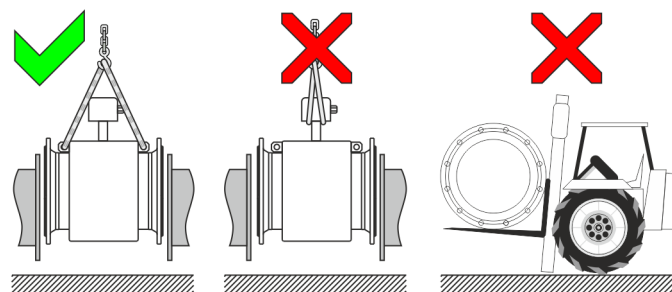

Figure 9: Transport instructions - > DN 450

- Using a forklift to transport flange device can dent the housing.
- Flange devices must not be lifted by the center of the housing when using a forklift for transport.
- Flange devices must not be lifted by the terminal box or by the center of the housing.
- Only the transport lugs fitted to the device can be used to lift the device and insert it into the piping.

Storing the device

Bear the following points in mind when storing devices:

- Store the device in its original packaging in a dry and dust-free location.
- Observe the permitted ambient conditions for transport and storage.
- Avoid storing the device in direct sunlight.
- In principle, the devices may be stored for an unlimited period. However, the warranty conditions stipulated in the order confirmation of the supplier apply.

Temperature data

Storage temperature

Model SE41F

-20 to 70 °C (-4 to 158 °F)

Model SE21_

-25 to 70 °C (-13 to 158 °F)

The ambient conditions for the transport and storage of the device correspond to the ambient conditions for operation of the device.

Adhere to the device data sheet!

Returning devices

For the return of devices, follow the instructions in **Maintenance / Repair** on page 101.

5 Installation

Safety instructions

WARNING

Risk of injury due to process conditions.

The process conditions, for example high pressures and temperatures, toxic and aggressive measuring media, can give rise to hazards when working on the device.

- Before working on the device, make sure that the process conditions do not pose any hazards.
- If necessary, wear suited personal protective equipment when working on the device.
- Depressurize and empty the device / piping, allow to cool and purge if necessary.

WARNING

Risk of injury due to live parts!

When the housing is open, contact protection is not provided and EMC protection is limited.

- Before opening the housing, switch off the power supply.

Installation conditions

General

The following points must be observed during installation:

- The flow direction must correspond to the marking, if present
- The maximum torque for all flange screws must be complied with
- Secure flange screws and nuts against pipe vibration.
- The devices must be installed without mechanical tension (torsion, bending)
- Install flange devices / wafer-type devices with plane parallel counterflanges and use appropriate gaskets only
- Use gaskets made from a material that is compatible with the measuring medium and measuring medium temperature.
- Gaskets must not extend into the flow area, since possible turbulence could influence the accuracy of the device
- The piping may not exert any inadmissible forces or torques on the device.
- Make sure that the temperature limits are not up-scaled during operation of the device.
- Vacuum shocks in the piping should be avoided to prevent damage to the liners (PTFE liner). Vacuum shocks can destroy the device.
- Do not remove the sealing plugs in the cable glands until you are ready to install the electrical cable
- Make sure the gaskets for the housing cover are seated correctly. Carefully seal the cover. Tighten the cover fittings
- The transmitter with a remote mount design must be installed at a largely vibration-free location
- Do not expose the transmitter and sensor to direct sunlight. Provide appropriate sun protection as necessary. If necessary, provide a suited means of sun protection.
- When installing the transmitter in a control cabinet, make sure adequate cooling is provided

Brackets

NOTICE

Potential damage to the device!

Improper support for the device may result in a deformed housing and damage to internal magnetic coils.

- Place the supports at the edge of the sensor housing (see arrows in Figure 10).

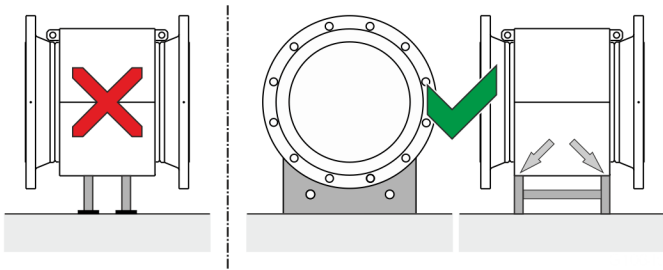

Figure 10: Support for nominal diameters greater than DN 400

Devices with nominal diameters larger than DN 400 must be mounted on a sufficiently strong foundation with support.

Gaskets

The following points must be observed when installing gaskets:

- To achieve the best results, make sure that the gaskets and meter tube fit concentrically.
- To make sure that the flow profile is not distorted, the gaskets may not intrude in the piping cross-section.
- The use of graphite with the flange or process connection gaskets is prohibited. This is because, in some instances, an electrically conductive coating may form on the inside of the meter tube.

Devices with hard rubber or soft rubber liner

- Devices with a hard / soft rubber liner always require additional gaskets
- ABB recommends using gaskets made from rubber or rubber-like sealing materials
- When selecting the gaskets, make sure that the tightening torques specified in chapter **Torque information** on page 20 are followed.

Devices with a PTFE, PFA or ETFE liner

- In principle, devices with a PTFE, PFA or ETFE liner do not require additional gaskets.

Flow direction

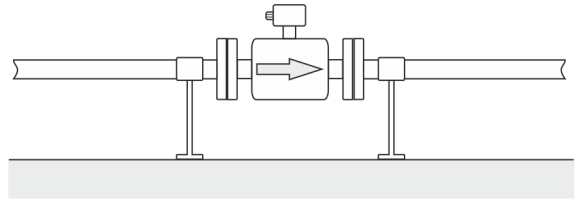

Figure 11: Flow direction

The device measures the flow rate in both flow directions. Forward flow is the factory setting, as shown in Figure 11.

Electrode axis

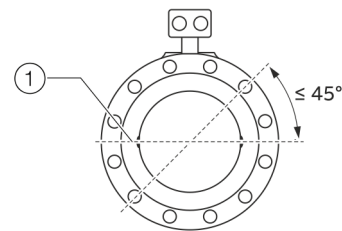

Figure 12: Orientation of the electrode axis

The electrode axis ① should be horizontal if at all possible or no more than 45° from horizontal.

... 5 Installation

... Installation conditions

Mounting position

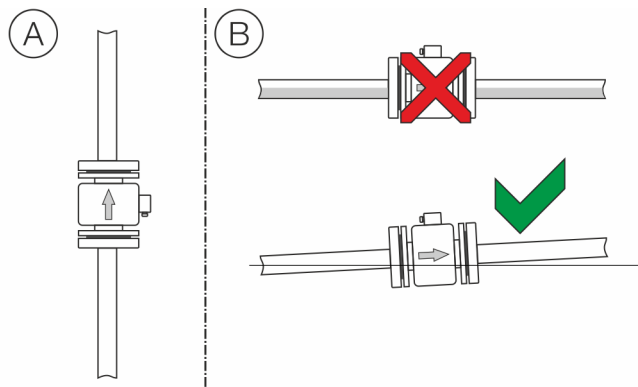

Figure 13: Mounting position

- Ⓐ Vertical installation for measuring abrasive materials, preferably with flow in upward direction.
- Ⓑ For a horizontal installation, the meter tube must always be completely filled with the measuring medium. Provide for a slight incline of the connection for degassing.

Note

For hygienic applications, the vertical mounting position is preferred.

For a horizontal mounting position, make sure that the sensor is installed to be self-draining.

Grounding

The flowmeter sensor must be connected to ground potential.

For technical reasons, this potential must be identical to the potential of the measuring medium.

For plastic or insulated lined pipelines, the measuring medium is grounded by installing grounding rings.

When there are stray potentials present in the pipeline, a grounding ring is recommended on both ends of the flowmeter sensor.

Sensor insulation

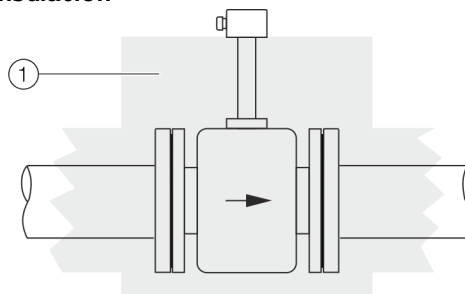

- ① Insulation

Figure 14: Insulation of the flowmeter sensor

In the high temperature design, the flowmeter sensor can be completely thermally insulated. After the unit is installed, the piping and sensor must be insulated in accordance with the figure.

Inlet and outlet sections

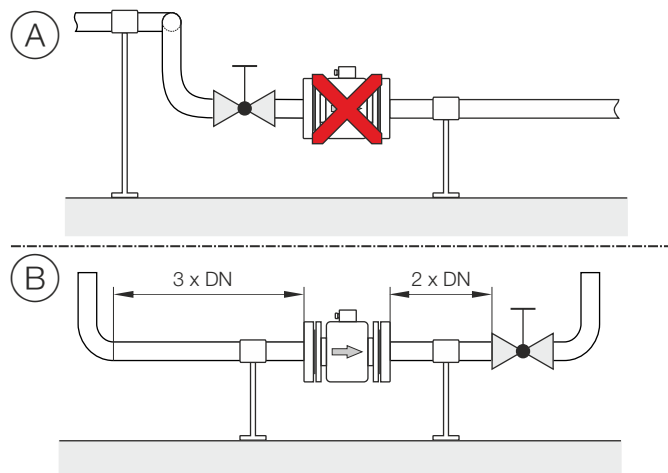

- ① Double elbow ② Turn-off device

Figure 15: Inlet and outlet section, turn-off devices

The measuring principle is independent of the flow profile as long as standing eddies do not extend into the measured value formation, such as may for example occur after double elbows, in the event of tangential inflow, or where half-open gate valves are located upstream of the sensor. In such cases, measures must be put in place to normalize the flow profile.

Ⓐ Do not install fittings, manifolds, valves, etc., right before the flowmeter sensor.

Ⓑ Inlet / outlet sections: length of the straight piping upstream and downstream on the sensor.

Experience has shown that, in most installations, straight inlet sections $3 \times \text{DN}$ long and straight outlet sections $2 \times \text{DN}$ long are sufficient (DN = nominal diameter of the flowmeter sensor).

For test stands, the reference conditions of $10 \times \text{DN}$ straight inlet and $5 \times \text{DN}$ straight outlet must be provided, in accordance with EN 29104 / ISO 9104.

Valves or other turn-off devices should be installed in the outlet section.

Valve flaps must be installed so that the valve damper plate does not extend into the flowmeter sensor.

Butterfly valves should not be installed upstream the flowmeter.

Free inlet or outlet

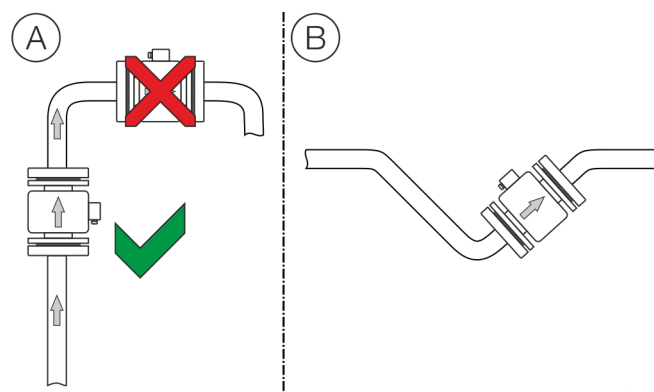

Figure 16: Free inflow and outflow

Ⓐ For a free outflow, do not install flowmeter at the highest point of the piping or on its outflow side, since the measuring tube may run empty, creating air bubbles.

Ⓑ For free inflow/outflow, provide an invert to make sure that the piping is always full

Mounting with heavily contaminated measuring media

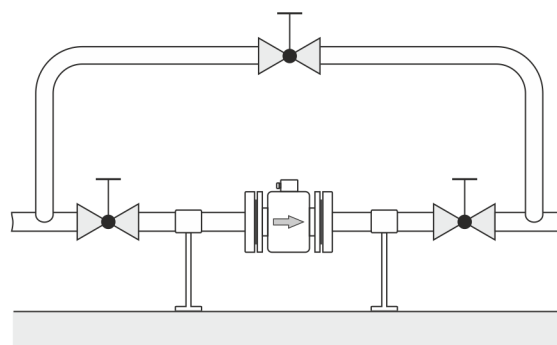

Figure 17: Bypass line

For strongly contaminated measuring media, a bypass line in accordance with the figure is recommended so that operation of the system can continue to run without interruption during mechanical cleaning.

Installing the sensor

NOTICE

Damage to the device

Damage to the device due to improper assembly.

- The use of graphite with the flange or process connection gaskets is prohibited. This is because, in some instances, an electrically conductive coating may form on the inside of the meter tube.
- Vacuum shocks in the piping should be avoided to prevent damage to the liners (PTFE-liner). Vacuum shocks can destroy the device.

The flowmeter sensor can be installed at any location in the piping while taking the installation conditions into account.

1. Remove protective plates, if present, to the right and left of the meter tube. To prevent possible leakage, make sure that the liner on the flange is not cut or damaged.
2. Position the flowmeter sensor plane parallel and centered between the piping.
3. Install gaskets between the surfaces, see **Torque information** on page 20.

Note

For achieve the best results, ensure the gaskets fit concentrically with the meter tube

To guarantee that the flow profile is not distorted, the gaskets must not protrude into the piping.

4. Use the appropriate screws for the holes in accordance with **Torque information** on page 20.
5. Slightly grease the threaded nuts.
6. Tighten the nuts in a crosswise manner as shown in the figure. Observe the tightening torques in accordance with **Torque information** on page 20!

First tighten the nuts to approx. 50 % of the maximum torque, then to 80 %, and finally a third time to the maximum torque. Do not exceed the max. torque.

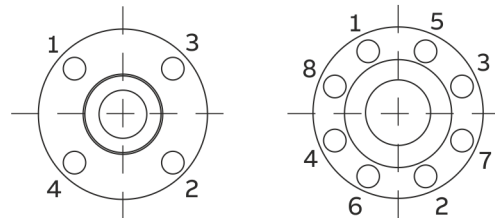

Figure 21: Tightening sequence for the flange screws

... 5 Installation

Torque information

Flange and wafer type devices, model SE41F / SE21W

Note

The specified torques are valid only for greased threads and piping that is not subject to tensile stress.

The specified torque values are dependent on variables (temperature, bolt material, gasket material, lubricants, etc.) which are not within the control of the manufacturer. Therefore the values should be regarded as indicative only.

Nominal diameter DN		Nominal pressure PN	Max. tightening torque [Nm]			
mm	In		Hard/soft rubber lining		PTFE, PFA, ETFE lining	
			Steel flange	Stainless steel flange	Steel flange	Stainless steel flange
3 to 10 ¹⁾	1/10 to 3/8 ¹⁾	PN40	-	-	12.43	12.43
		PN63/100	-	-	12.43	12.43
		CL150	-	-	12.98	12.98
		CL300	-	-	4.94	17.38
		JIS 10K	-	-	12.43	12.43
15	1/2"	PN40	6.74	4.29	14.68	14.68
		PN63/100	13.19	11.2	22.75	22.75
		CL150	3.65	3.65	12.98	12.98
		CL300	4.94	3.86	4.94	17.38
		CL600	9.73	9.73	-	-
20	3/4"	JIS 10K	2.84	1.37	14.68	14.68
		PN40	9.78	7.27	20.75	20.75
		PN63/100	24.57	20.42	42.15	42.15
		CL150	5.29	5.29	18.49	18.49
		CL300	9.77	9.77	33.28	33.28
25	1"	CL600	15.99	15.99	-	-
		JIS 10K	4.1	1.88	20.75	20.75
		PN40	13.32	8.6	13.32	8.6
		PN63/100	32.09	31.42	53.85	53.85
		CL150	5.04	2.84	23.98	23.98
32	1 1/4"	CL300	17.31	16.42	65.98	38.91
		CL600	22.11	22.11	-	-
		JIS 10K	8.46	5.56	26.94	26.94
		PN40	27.5	15.01	45.08	45.08
		PN63/100	42.85	41.45	74.19	70.07
40	1 1/2"	CL150	4.59	1.98	29.44	29.44
		CL300	25.61	14.22	45.52	45.52
		CL600	34.09	34.09	-	-
		JIS 10K	9.62	4.9	45.08	45.08
		PN40	30.44	23.71	56.06	56.06
		PN63/100	62.04	51.45	97.08	97.08
		CL150	5.82	2.88	36.12	36.12
		CL300	33.3	18.41	73.99	73.99
		CL600	23.08	23.08	-	-
		JIS 10K	12.49	6.85	56.06	56.06

1) Connection flange DIN/EN1092-1 = DN10 (3/8"), connection flange ASME = DN15 (1/2")

Nominal diameter DN		Nominal pressure PN	Max. tightening torque [Nm]			
mm	Inch		Hard/soft rubber lining		PTFE, PFA, ETFE lining	
			Steel flange	Stainless steel flange	Steel flange	Stainless steel flange
50	2"	PN40	41.26	27.24	71.45	71.45
		PN63	71.62	60.09	109.9	112.6
		CL150	22.33	22.33	66.22	66.22
		CL300	17.4	22.33	38.46	38.46
		CL600	35.03	35.03	-	-
		JIS 10K	17.27	10.47	71.45	71.45
65	2½"	PN16	14.94	8	37.02	39.1
		PN40	30.88	21.11	43.03	44.62
		PN63	57.89	51.5	81.66	75.72
		CL150	30.96	30.96	89.93	89.93
		CL300	38.38	27.04	61.21	61.21
		CL600	53.91	53.91	-	-
80	3"	JIS 10K	14.94	8	37.02	39.1
		PN40	38.3	26.04	51.9	53.59
		PN63	63.15	55.22	64.47	80.57
		CL150	19.46	19.46	104.6	104.6
		CL300	75.54	26.91	75.54	75.54
		CL600	84.63	84.63	-	-
100	4"	JIS 10K	16.26	9.65	45.07	47.16
		PN16	20.7	12.22	49.68	78.19
		PN40	67.77	47.12	78.24	78.19
		PN63	107.4	95.79	148.5	119.2
		CL150	17.41	7.82	76.2	76.2
		CL300	74.9	102.6	102.6	102.6
125	5"	CL600	147.1	147.1	-	-
		JIS 10K	20.7	12.22	49.68	78.19
		PN16	29.12	18.39	61.4	64.14
		PN40	108.5	75.81	123.7	109.6
		PN63	180.3	164.7	242.6	178.2
		CL150	24.96	11.05	98.05	98.05
150	6"	CL300	81.64	139.4	139.4	139.4
		CL600	244.1	244.1	-	-
		PN16	46.99	23.7	81.23	85.08
		PN40	143.5	100.5	162.5	133.5
		PN63	288.7	269.3	371.3	243.4
		CL150	30.67	13.65	111.4	111.4
200	8"	CL300	101.4	58.4	123.6	123.6
		CL600	218.4	218.4	-	-
		PN10	45.57	27.4	113	116.9
		PN16	49.38	33.82	70.42	73
		PN25	100.6	69.17	109.9	112.5
		PN40	196.6	144.4	208.6	136.8
		PN63	350.4	331.8	425.5	282.5
		CL150	49.84	23.98	158.1	158.1
		CL300	133.9	78.35	224.3	224.3

... 5 Installation

... Torque information

Nominal diameter DN		Nominal pressure PN	Max. tightening torque [Nm]			
mm	Inch		Hard/soft rubber lining		PTFE, PFA, ETFE lining	
			Steel flange	Stainless steel flange	Steel flange	Stainless steel flange
250	10"	PN10	23.54	27.31	86.06	89.17
		PN16	88.48	61.71	99.42	103.1
		PN25	137.4	117.6	166.5	133.9
		PN40	359.6	275.9	279.9	241
		CL150	55.18	27.31	146.1	148.3
		CL300	202.7	113.2	246.4	246.4
300	12"	PN10	58.79	38.45	91.29	94.65
		PN16	122.4	85.64	113.9	114.8
		PN25	180.6	130.2	151.1	106.9
		PN40	On request	On request	On request	On request
		CL150	90.13	50.37	203.5	198
		CL300	333.3	216.4	421.7	259.1
350	14"	PN10	69.62	47.56	72.49	75.22
		PN16	133.6	93.61	124.9	104.4
		PN25	282.3	204.3	226.9	167.9
		CL150	144.8	83.9	270.5	263
		CL300	424.1	252.7	463.9	259.4
		400	16"	PN10	108.2	75.61
PN16	189			137.2	191.4	153.8
PN25	399.4			366	404	246.7
CL150	177.6			100	229.3	222.8
CL300	539.5			318.8	635.8	328.1
450	18"			CL150	218.6	120.5
		CL300	553.8	327.2	660.9	300
500	20"	PN10	141.6	101.4	153.9	103.5
		PN16	319.7	245.4	312.1	224.8
		PN25	481.9	350.5	477.1	286
		CL150	212.5	116	237.3	230.4
		CL300	686.3	411.8	786.8	363.1
600	24"	PN10	224.7	164.8	238.7	149.1
		PN16	515.1	399.9	496.7	365.3
		PN25	826.2	600.3	750.7	539.2
		CL150	356.6	202.8	451.6	305.8
		CL300	1188	719	1376	587.4
700	28"	PN10	267.7	204.9	On request	On request
		PN16	455.7	353.2	On request	On request
		PN25	905.9	709.2	On request	On request
		CL150	364.1	326.2	449.2	432.8
		CL300	1241	On request	On request	On request
750	30"	CL150	423.8	380.9	493.3	442
		CL300	1886	On request	On request	On request

Nominal diameter DN		Nominal pressure PN	Max. tightening torque [Nm]			
mm	Inch		Hard/soft rubber lining		ETFE lining	
			Steel flange	Stainless steel flange	Steel flange	Stainless steel flange
800	32"	PN10	391.7	304.2	On request	On request
		PN16	646.4	511.8	On request	On request
		PN25	1358	1087	On request	On request
		CL150	410.8	380.9	493.3	380.9
		CL300	2187	On request	On request	On request
900	36"	PN10	387.7	296.3	On request	On request
		PN16	680.8	537.3	On request	On request
		PN25	1399	1119	On request	On request
		CL150	336.2	394.6	511	458.5
		CL300	1972	On request	On request	On request
1000	40"	PN10	541.3	419.2	On request	On request
		PN16	955.5	756.1	On request	On request
		PN25	2006	1612	On request	On request
		CL150	654.2	598.8	650.6	385.1
		CL300	2181	On request	On request	On request

Variable process connections model SE21

Nominal diameter DN		Max. tightening torque
mm	inch	Nm
3 to 10	3/8"	8
15	1/2"	10
20	3/4"	21
25	1"	31
32	1 1/4"	60
40	1 1/2"	80
50	2"	5
65	2 1/2"	5
80	3"	15
100	4"	14

... 5 Installation

Measuring range table

Nominal diameter DN		Min. flow velocity measuring range 0 to 0.5 m/s						Max. flow velocity measuring range 0 to 10 m/s					
3	$\frac{1}{10}$	0	up to	0.2	l/min	0.0529	US gal/min	0	up to	4	l/min	1.06	US gal/min
4	$\frac{5}{32}$	0	up to	0.4	l/min	0.1	US gal/min	0	up to	8	l/min	2.1	US gal/min
6	$\frac{1}{4}$	0	up to	1	l/min	0.3	US gal/min	0	up to	20	l/min	5.3	US gal/min
8	$\frac{5}{16}$	0	up to	1.5	l/min	0.4	US gal/min	0	up to	30	l/min	7.9	US gal/min
10	$\frac{3}{8}$	0	up to	2.25	l/min	0.6	US gal/min	0	up to	45	l/min	12	US gal/min
15	$\frac{1}{2}$	0	up to	5.0	l/min	1.3	US gal/min	0	up to	100	l/min	36	US gal/min
20	$\frac{3}{4}$	0	up to	7.5	l/min	2.0	US gal/min	0	up to	150	l/min	40	US gal/min
25	1	0	up to	10	l/min	2.6	US gal/min	0	up to	200	l/min	53	US gal/min
32	1 $\frac{1}{4}$	0	up to	20	l/min	5.3	US gal/min	0	up to	400	l/min	106	US gal/min
40	1 $\frac{1}{2}$	0	up to	30	l/min	7.9	US gal/min	0	up to	600	l/min	159	US gal/min
50	2	0	up to	3	m ³ /h	13	US gal/min	0	up to	60	m ³ /h	264	US gal/min
65	2 $\frac{1}{2}$	0	up to	6	m ³ /h	26	US gal/min	0	up to	120	m ³ /h	528	US gal/min
80	3	0	up to	9	m ³ /h	40	US gal/min	0	up to	180	m ³ /h	793	US gal/min
100	4	0	up to	12	m ³ /h	53	US gal/min	0	up to	240	m ³ /h	1057	US gal/min
125	5	0	up to	21	m ³ /h	92	US gal/min	0	up to	420	m ³ /h	1849	US gal/min
150	6	0	up to	30	m ³ /h	132	US gal/min	0	up to	600	m ³ /h	2642	US gal/min
200	8	0	up to	54	m ³ /h	238	US gal/min	0	up to	1080	m ³ /h	4755	US gal/min
250	10	0	up to	90	m ³ /h	396	US gal/min	0	up to	1800	m ³ /h	7925	US gal/min
300	12	0	up to	120	m ³ /h	528	US gal/min	0	up to	2400	m ³ /h	10567	US gal/min
350	14	0	up to	165	m ³ /h	726	US gal/min	0	up to	3300	m ³ /h	14529	US gal/min
400	16	0	up to	225	m ³ /h	991	US gal/min	0	up to	4500	m ³ /h	19813	US gal/min
450	18	0	up to	300	m ³ /h	1321	US gal/min	0	up to	6000	m ³ /h	26417	US gal/min
500	20	0	up to	330	m ³ /h	1453	US gal/min	0	up to	6600	m ³ /h	29059	US gal/min
600	24	0	up to	480	m ³ /h	2113	US gal/min	0	up to	9600	m ³ /h	30380	US gal/min
700	28	0	up to	660	m ³ /h	2906	US gal/min	0	up to	13200	m ³ /h	58118	US gal/min
800	32	0	up to	900	m ³ /h	3963	US gal/min	0	up to	18000	m ³ /h	79252	US gal/min
900	36	0	up to	1200	m ³ /h	5283	US gal/min	0	up to	24000	m ³ /h	105669	US gal/min
1000	40	0	up to	1350	m ³ /h	5944	US gal/min	0	up to	27000	m ³ /h	118877	US gal/min

Grounding

General information on grounding

Observe the following items when grounding the device:

- Use the supplied green/yellow cable as a grounding wire.
- Connect the ground screw for the sensor (on flange and transmitter housing) to the station ground.
- The terminal box must also be grounded.
- For plastic piping or piping with insulating liner, the ground is provided by the grounding plate or grounding electrodes.
- When stray potentials are present, install a grounding plate upstream and downstream of the sensor.
- For measurement-related reasons, the potential in the station ground and in the piping should be identical.
- Additional grounding on the terminals is not required.

Note

If the flowmeter is installed in plastic or earthenware pipelines, or in pipelines with an insulating lining, transient current may flow through the grounding electrode in special cases. In the long term, this may destroy the sensor, since the ground electrode will in turn degrade electrochemically. In these special cases, the connection to the ground must be performed using grounding plates.

Metal pipe with fixed flanges

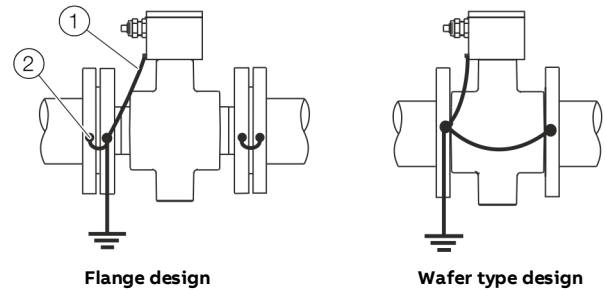

Figure 22: Grounding connections

1. Insert M6×12 threads (2) in the flanges for the piping and the sensor.
2. Secure the ground straps (1) with screw, spring washer and washer in accordance with the figure.
3. Use a copper wire (minimum 2.5 mm² (14 AWG)) to establish a connection between the ground connection of the sensor and a suited grounding point.

... 5 Installation

... Grounding

Metal pipe with loose flanges

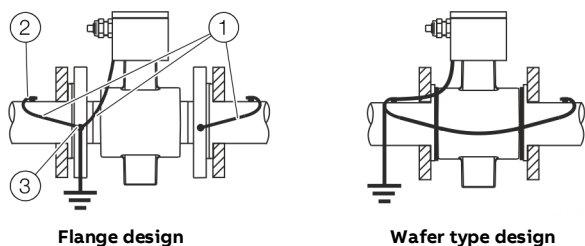

Figure 23: Grounding connections

1. Solder the threaded nuts ② M6 to the piping.
2. Insert M6x12 threads (3) in the flanges of the sensor.
3. Secure the ground straps ① with nuts, spring washer and washer in accordance with the figure, and connect to the sensor with ground connection ③.
4. Use a copper wire (minimum 2.5 mm² (14 AWG)) to establish a connection between the ground connection ③ and a suited grounding point.

Non-metallic pipes or pipes with insulating liner

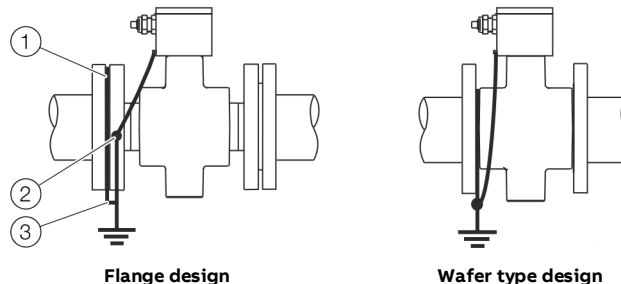

Figure 24: Grounding connections

For plastic piping or piping with an insulating liner, the grounding of the measuring medium is provided by the grounding plate as shown in the figure below or via grounding electrodes that must be installed in the device (option). If grounding electrodes are used, the grounding plate is not necessary.

1. Install the sensor with grounding plate ① in the piping.
2. Insert M6x12 threads ② in the flange of the sensor.
3. Connect the terminal lug for the grounding plate ③ and ground connection on the sensor ② with the grounding strap.
4. Use a copper wire (minimum 2.5 mm² (14 AWG)) to establish a connection between the ground connection ② and a good grounding point.

Ground for devices with protection plates

The protection plates are used to protect the edges of the meter tube liner, e.g. for abrasive media. In addition, they function as a grounding plate.

- For plastic protection plates or piping with an insulating liner, electrically connect in the same manner as a grounding plate.

Grounding with conductive PTFE grounding plate

Grounding plates made of conductive PTFE are optionally available for nominal diameter ranges of DN 10 to 250.

These are installed similar to conventional grounding plates.

6 Electrical connections

Safety instructions

WARNING

Risk of injury due to live parts.

Improper work on the electrical connections can result in electric shock.

- Connect the device only with the power supply switched off.
- Observe the applicable standards and regulations for the electrical connection.

The electrical connection may only be established by authorized specialist personnel and in accordance with the connection diagrams.

The electrical connection information in this manual must be observed; otherwise, the IP rating may be adversely affected. Ground the measurement system according to requirements.

... 6 Electrical connections

Preparing and routing the signal and magnetic coil cable

Preparing for sensor model SE21

Cut to length and terminate both cables as shown.

Note

Use wire end sleeves.

Signal cable D173D025U01

Preparing the transmitter side

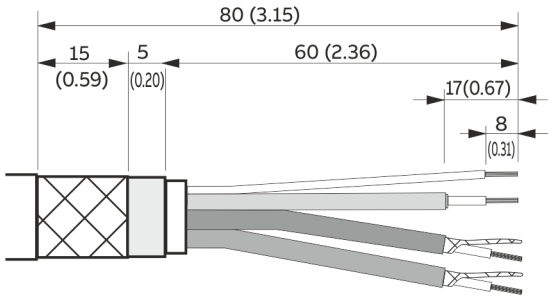

Magnet coil cable D173D147U01

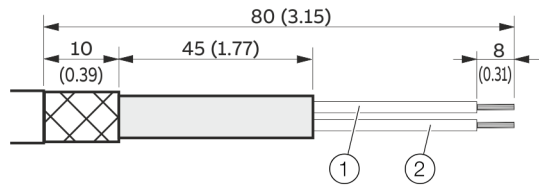

Preparing the sensor side

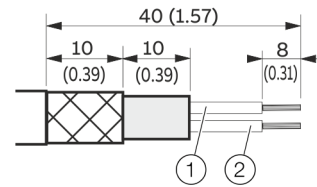
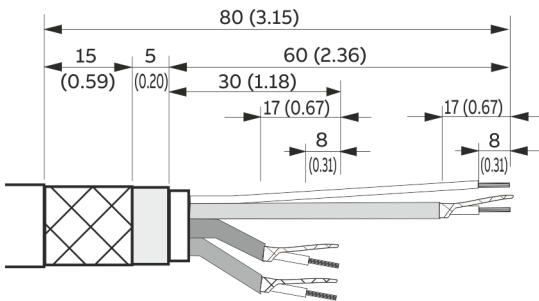

Cable identifiers

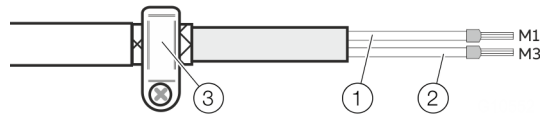
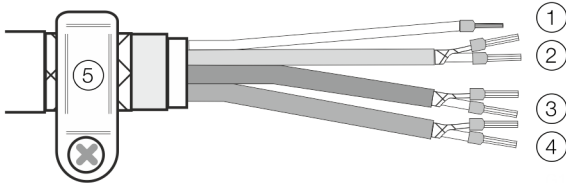

- ① Measuring potential, yellow
- ② Reference, white
- ③ Signal cable, red
- ④ Signal cable, blue
- ⑤ SE clamp

- ① Magnetic coil, black
- ② Magnetic coil, black
- ③ SE clamp

Figure 25: Preparing the signal and magnetic coil cable sensor model SE21

Note

The shielding may not touch (signal short circuit).

Preparing for sensor model SE41F

Cut to length and terminate both cables as shown.

Note

Use wire end sleeves.

Signal cable D173D025U01

Preparing the transmitter side

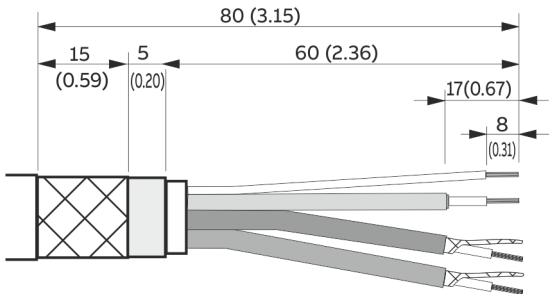

Magnet coil cable D173D147U01

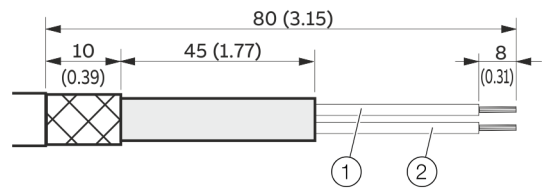

Preparing the sensor side

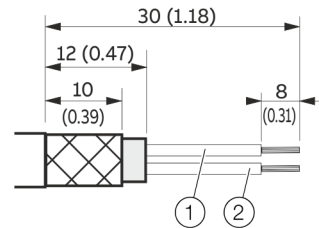
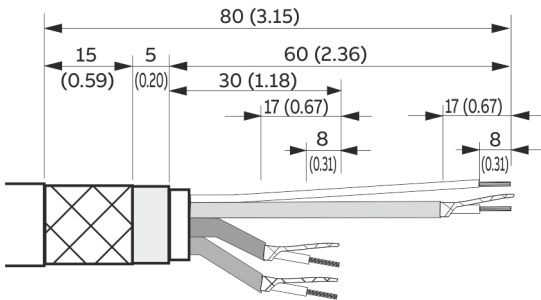

Cable identifiers

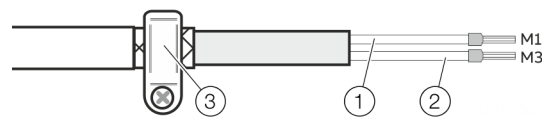
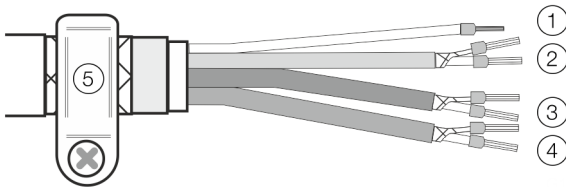

- ① Measuring potential, yellow
- ② Reference, white
- ③ Signal cable, red
- ④ Signal cable, blue
- ⑤ SE clamp

- ① Magnetic coil, black
- ② Magnetic coil, black
- ③ SE clamp

Figure 26: Preparing the signal and magnetic coil cable sensor model SE21, SE21F

Note

The shielding may not touch (signal short circuit).

... 6 Electrical connections

... Preparing and routing the signal and magnetic coil cable

Routing the signal and magnetic coil cable

Observe the following points when routing cables:

- The signal and magnetic coil cable carries a voltage signal of only a few millivolts and therefore must be routed the shortest distance possible. The maximum permissible signal cable length is 50 m or 200 m, if the flowmeter primary is equipped with a preamplifier.
- Avoid the vicinity of electrical equipment or switching elements that can create stray fields, switching pulses and induction. If this is not possible, run the signal / magnet coil cable through a metal pipe and connect this to the station ground.
- All lines must be shielded and connected to operational ground.
- Do not run the signal cable and the magnetic coil cable over junction boxes or terminal blocks.
- To shield against magnetic interspersion, the cable contains outer shielding that is attached to the SE clamp.
- Make sure during installation that the cable is provided with a water trap . For vertical installation, align the cable glands pointing downward.

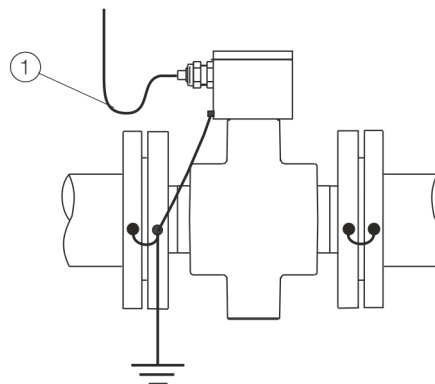
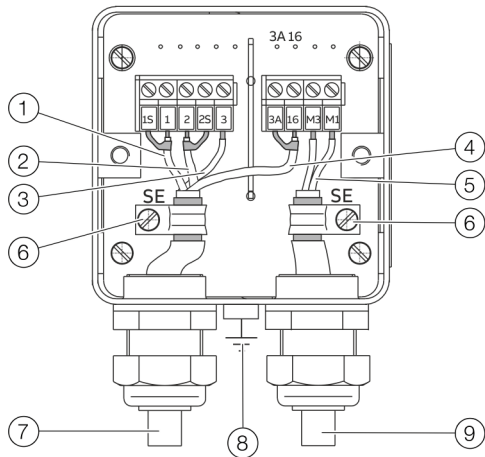

Figure 27: Water trap

Connecting the sensor

Connecting the signal and magnet coil cables

The flowmeter sensor is connected to the transmitter via the signal / magnet coil cables (part no. D173D025U01 / D173D147U01). The coils of the flowmeter sensor are supplied with a field voltage by the transmitter over terminals M1/M3. Connect the cables to the sensor in accordance with the following drawing, using a screwdriver with proper size and width.



Terminal box model SE21, SE21F

- ① red
- ② blue
- ③ yellow
- ④ white
- ⑤ black
- ⑥ SE clamp
- ⑦ signal cable
- ⑧ ground connection
- ⑨ magnetic coil cable

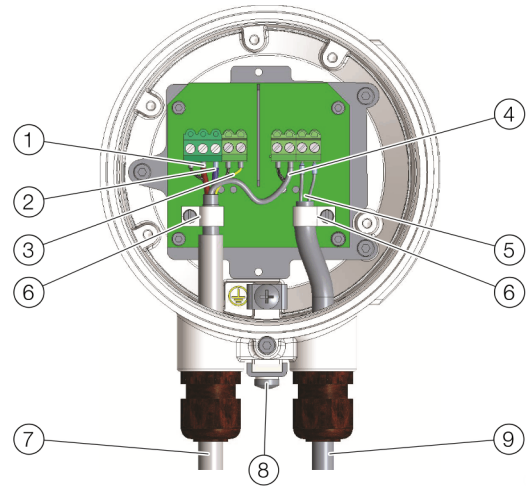

Terminal box model SE41F

- ① red
- ② blue
- ③ yellow
- ④ white
- ⑤ black
- ⑥ SE clamp
- ⑦ signal cable
- ⑧ ground connection
- ⑨ magnetic coil cable

Figure 28: Connection to sensor

Terminal designation	Connection
1 + 2	Wires for the measuring signal (red, blue)
1S, 2S	Shielding for signal wires
U+, U-	Power supply for preamplifier via signal cable shielding
16	Wire for reference signal (white)
3A	Shielding for reference signal cable
3	Measuring ground (yellow)
M1 + M3	Connections for magnetic field excitation (black)
SE	Outer cable shield

... 6 Electrical connections

Connection with IP rating IP 68

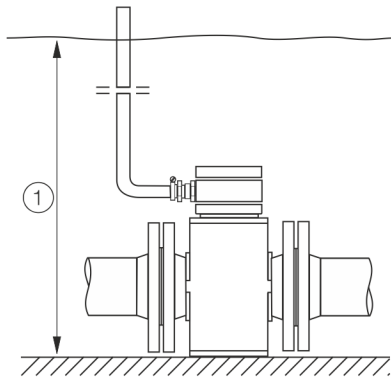

① Maximum flooding height 5 m (16.4 ft)

Figure 29: Maximum flooding height for IP 68 sensors

For sensors with IP rating IP 68, the maximum flooding height is 5 m (16.4 ft).

The supplied signal cable fulfills all the submersion requirements.

The sensor is type-tested in accordance with EN 60529. Test conditions:

- 14 days at a flooding height of 5 m 16.4 ft).

Electrical connection

NOTICE

Adverse effect on the IP rating IP 68

The IP rating IP 68 of the sensor may be adversely affected as a result of damage to the signal cable.

- The sheathing of the signal cable must not be damaged.

1. Use the supplied signal cable to connect the sensor and the transmitter.
2. Connect the signal cable in the terminal box of the sensor.
3. Route the cable from the terminal box to above the maximum flooding height of 5 m (16.4 ft).
4. Tighten the cable gland.
5. Carefully seal the terminal box. Make sure the gasket for the cover is seated properly.

Note

As an option, the sensor can be ordered with the signal cable already connected to the sensor and the terminal box already potted.

Potting the terminal box on-site

⚠ CAUTION

Danger to health!

The two-component potting compound is toxic – observe all relevant safety measures!

Comply with the safety data sheet of the two-component potting compound before preparations are started.

Risk notes:

- R20: Damaging to health when inhaled.
- R36/37/38: Irritates the eyes, respiratory organs and the skin.
- R42/43: Sensitization through inhaling and skin contact is possible.

Safety advice:

- S23: Do not inhale gas/smoke/humidity/aerosol.
- S24: Avoid contact with the skin.
- S37: Wear suited protective gloves.
- S63: In case of an accident due to inhaling: take the injured person out into the fresh air to rest.

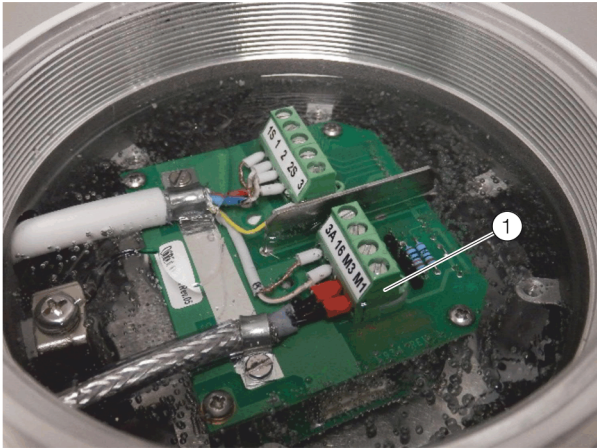

① Maximum fill level

Figure 30: Maximum fill level

If the terminal box is to be potted subsequently on-site, a special two-component potting compound can be ordered separately. Potting is only possible if the sensor is installed horizontally.

Observe the following instructions during work activity:

- Complete the installation before potting in order to avoid moisture penetration. Before starting, check all the connections for correct fitting and stability
- Do not overfill the terminal box. Keep the potting compound away from the O-ring and the gasket / groove (see Figure 30).
- Prevent the two-component potting compound from penetrating the cable conduit (Conduit) for an ½ in NPT installation (if used).

Connecting the transmitter

Connecting the power supply

The line voltage and power consumption are indicated on the name plate for the transmitter. The wire cross-section for the power supply must meet the requirements for the main fuse (VDE 0100). The power consumption is ≤ 45 VA (sensor including transmitter).

The power supply is connected to terminal L (phase), N (neutral), or 1+, 2-, and \oplus , in accordance with the information on the name plate.

The power supply cable must be rated for the current consumption of the flowmeter system. The leads must comply with IEC 227 and/or IEC 245.

Connect a switch or a line switch in the power supply line to the transmitter. This switch should be located near the transmitter and marked as being associated with the device. The transmitter and the sensor should be connected to functional ground \oplus in accordance with international standards.

Note

Please observe the limit values of the power supply (see 'Specification'). Please note that there is a voltage drop of the 24 V AC/DC power supply line if the cables are extremely long or if the conductor cross section is extremely small.

The pin configuration must be made in accordance with the electrical connections in **Terminal assignment** on page 35.

... 6 Electrical connections

... Connecting the transmitter

Connecting the signal and magnet coil cables

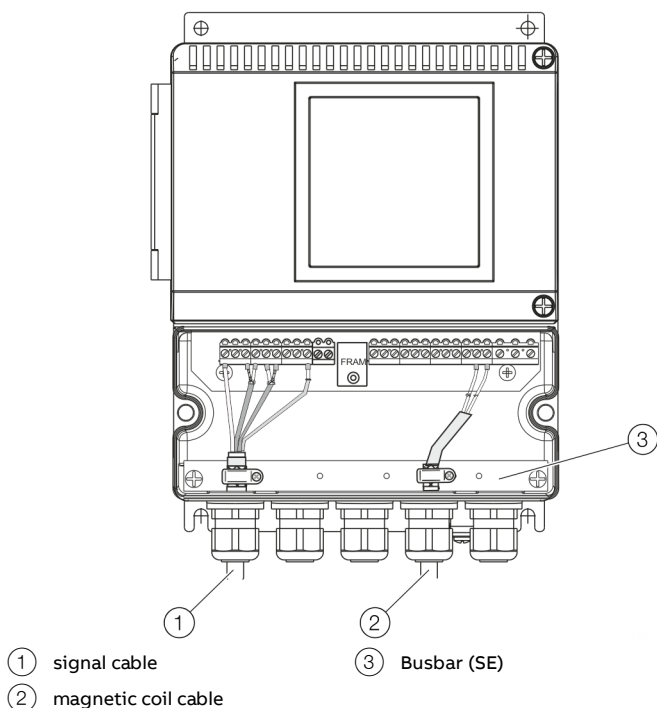

Figure 31: Transmitter

The outer shielding of the magnet coil cable is attached to the busbar via the 6 mm clip (from the accessory bag in the connection area). The outer shielding of the signal is routed in a similar manner. Use the 7 mm clip (from the accessory bag in the connection chamber). The shielding for the signal wires function as a 'driven shield' to transmit the measurement signal. The signal-reference voltage cable is attached to the sensor and transmitter according to the electrical connection.

Note

The power supply of the FSM4000 with preamplifier is connected via -U and +U, instead of 1S and 2S. If the flow indicator shows the incorrect flow direction after successful commissioning of the measuring system, e.g., reverse instead of forward, correct this in the 'Operating mode submenu' of the transmitter.

First switch off the programming protection ('Prog. Level / Specialist'). Then select the parameter 'Directional display' in the 'Operating mode submenu' and change 'normal' to 'inverse'. Finally, reactivate programming protection by selecting 'Prog. Level / Locked'.

Note

If the flowmeter sensor for older model meters (10D1422, 10DI1425, 10DS3111, DS4_, DS2_, 10D1462/72) is not yet equipped with the SE clamp, the outer shielding is connected to one side of the transmitter only. Use the 12 mm clip (from the accessory bag), if necessary (e.g., 10D1422).

Terminal assignment

Standard DN 3 to DN 1000 ($\frac{1}{16}$ to 40")

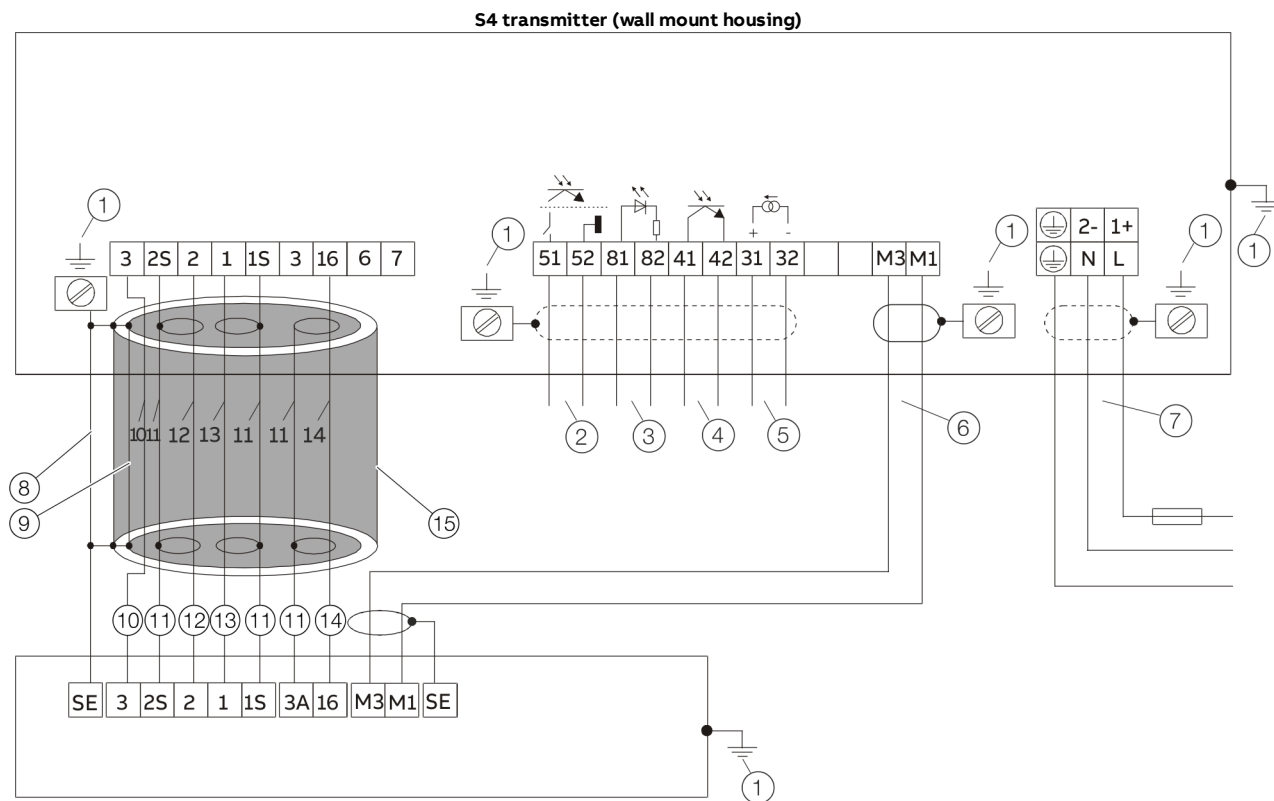

Sensor

- | | |
|--|--|
| ① Functional ground (busbar) | ⑧ Steel shielding |
| ② Pulse output ¹⁾ | ⑨ Aluminum foil |
| ③ Switch input ¹⁾ | ⑩ Yellow |
| ④ Switch output ¹⁾ | ⑪ Shield |
| ⑤ Current output ¹⁾ | ⑫ Blue |
| ⑥ Magnetic coil cable:
shielded 2 x 1 mm ² CE type 227 TEC 74
ABB order no. D173D147U01, 10 m included in shipment, standard | ⑬ Red |
| ⑦ Power supply
Low voltage: 100 ... 230 V AC, terminals L, N, ⊕
Extra-low voltage: 20.4 ... 26.4 V AC;
20.4 ... 31.2 V DC
Terminals 1+, 2-, ⊕
Frequency: 47 Hz ≤ f ≤ 53 Hz; 50 Hz power supply
56 Hz ≤ f ≤ 64 Hz; 60 Hz power supply | ⑭ White |
| | ⑮ Shielded signal cable:
ABB order no. D173D025U01, 10 m included in delivery |

Figure 32: Electrical connection sensor standard DN 10 ... DN 1000 ($\frac{1}{16}$... 40")

1) See the chapter 'Connection examples for peripherals' in the operating instruction and/or on the data sheet

Note

We recommend that shielded output cables be used with the shields connected to the functional ground at one end.

... 6 Electrical connections

... Terminal assignment

With preamplifier DN 3 to DN 1000 (1/10 to 40")

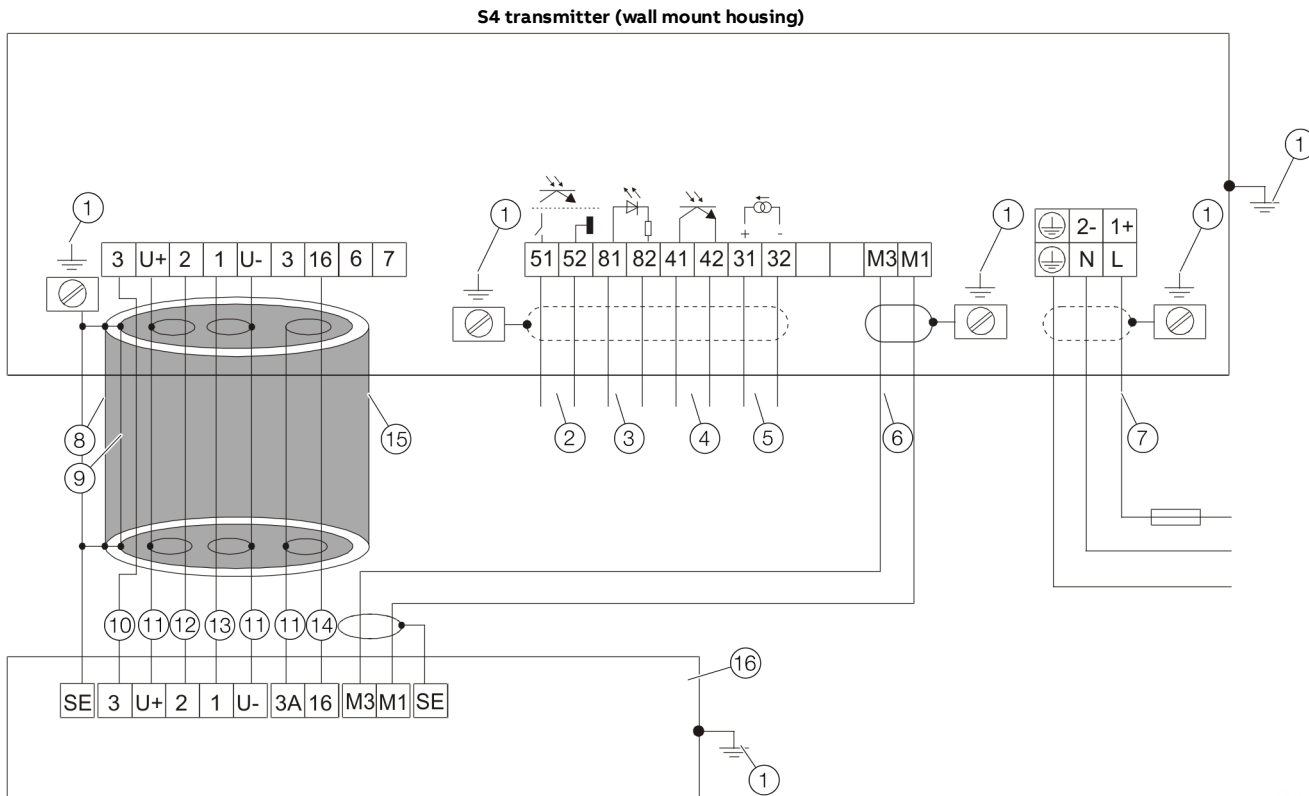

Sensor

- | | |
|---|---|
| ① Functional ground (busbar) | ⑧ Steel shielding |
| ② Pulse output ¹⁾ | ⑨ Aluminum foil |
| ③ Switch input ¹⁾ | ⑩ Yellow |
| ④ Switch output ¹⁾ | ⑪ Shield |
| ⑤ Current output ¹⁾ | ⑫ Blue |
| ⑥ Magnetic coil cable:
shielded 2 x 1 mm ² CE type 227 TEC 74
ABB order no. D173D147U01, 10 m included in shipment, standard | ⑬ Red |
| ⑦ Power supply
Low voltage: 100 to 230 V AC, terminals L, N, ⊕
Extra-low voltage: 20.4 to 26.4 V AC;
20.4 to 31.2 V DC
Terminals 1+, 2-, ⊕
Frequency: 47 Hz ≤ f ≤ 53 Hz; 50 Hz power supply
56 Hz ≤ f ≤ 64 Hz; 60 Hz power supply | ⑭ White |
| | ⑮ Shielded signal cable:: ABB order no. D173D025U01,
10 m included in delivery |
| | ⑯ with preamplifier (always at DN 3 to DN 8 [1/10 to 5/16"]) |

Figure 33: Electrical connection sensor with preamplifier DN 3 to DN 1000 (1/10 to 40"), transmitter field mount housing

1) See the chapter 'Connection examples for peripherals' in the operating instruction and/or on the data sheet

Note

- We recommend that shielded output cables be used with the shields connected to the functional ground at one end.
- If the sensor is equipped with a preamplifier for low conductivity or in nominal diameter range of DN 3 to DN 8 (1/10 to 5/16"), the shieldings of the signal wires must be connected to terminals U+ and U- on both the sensor and the transmitter.

**Retrofit for model 10D1422: DN 3 to DN 1000 (1/10 to 40"); model 10D1425 and 10DS3111A-E:
DN 500 to DN 1000 (20 to 40")**

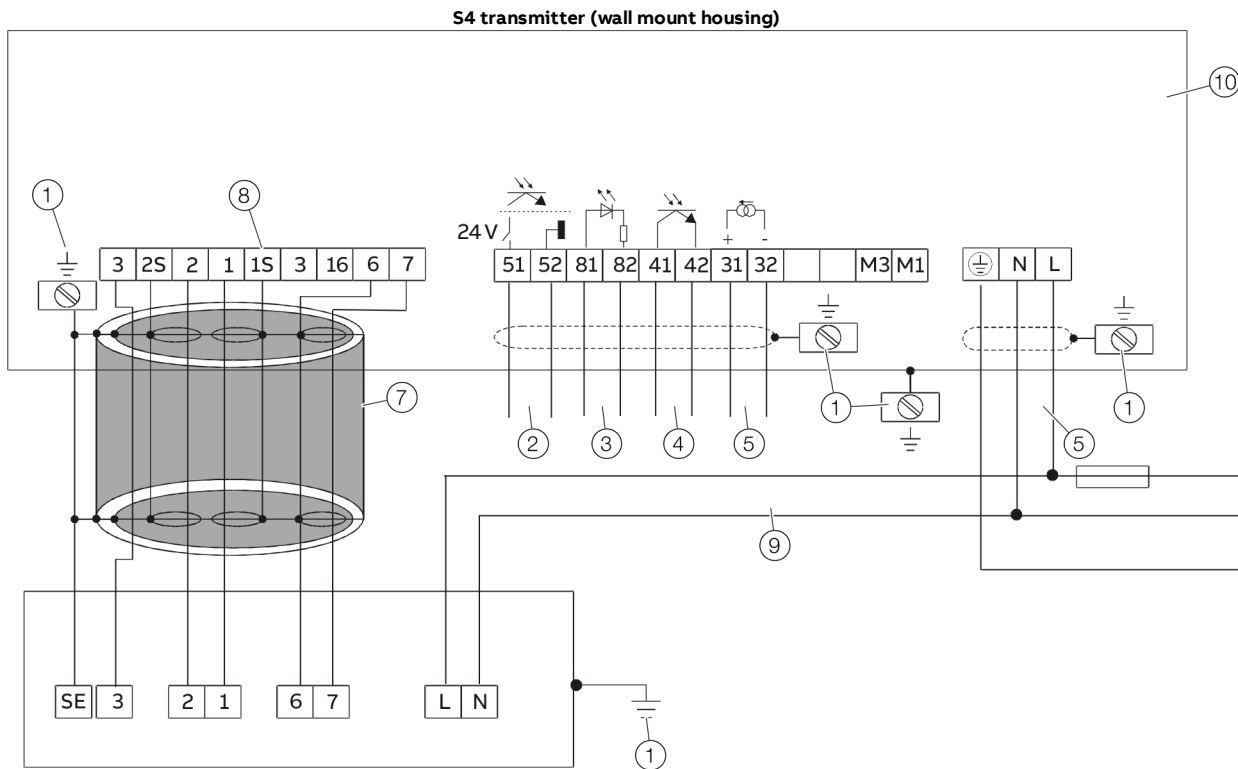

- ① Functional ground (busbar)
- ② Pulse output¹⁾
- ③ Switch input¹⁾
- ④ Switch output¹⁾
- ⑤ Current output¹⁾
- ⑥ Power supply

Low voltage: 100 to 230 V AC, terminals L, N, ⊕

Frequency: 47 Hz ≤ f ≤ 53 Hz; 50 Hz power supply

56 Hz ≤ f ≤ 64 Hz; 60 Hz power supply

Sensor

- ⑦ Shielded signal cable: ABB order no. D173D025U01
or incorporate in existing wiring
- ⑧ Reference cable:
Only for connection to model 10D1422
Close terminals: 6,7 and hook switch S903
- ⑨ Magnetic coil supply:
Magnet coil supply via supply power
- ⑩ Terminal board: D685A1020U03

Figure 34: Sensor standard DN 3 to DN 1000 (1/10 to 40"), transmitter field mount housing

1) See the chapter 'Connection examples for peripherals' in the operating instruction and/or on the data sheet

Note

We recommend that shielded output cables be used with the shields connected to the functional ground at one end.

... 6 Electrical connections

Digital communication

HART® protocol

The device is registered with the HART Communication Foundation.

Note

The HART® protocol is an unsecured protocol (in terms of IT and cyber security), as such the intended application should be assessed to ensure that this protocol is suitable before implementation.

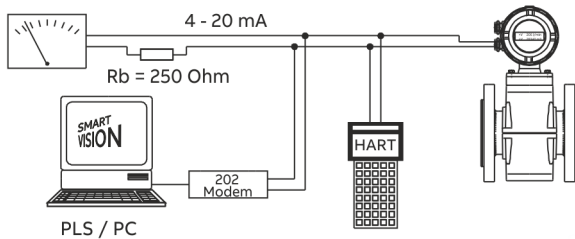

Figure 35: HART communication

HART protocol

Configuration	Directly on the device Software DAT200 Asset Vision Basic (+ HART-DTM)
Transmission	FSK modulation on current output 4 to 20 mA according to Bell 202 Standard
Max. signal amplitude	1.2 mAss
Current output load	Min. 250 Ω, max. = 560 Ω
Cable	AWG 24 twisted
Max. cable length	1500 m
Baud rate	1200 baud
Display	Log. 1: 1200 HZ Log. 0: 2200 Hz

For additional information, see the separate interface description.

System integration

In conjunction with the DTM (Device Type Manager) available for the device (software version B.10 and higher), communication (configuration, parameterization) can occur with the corresponding framework applications according to FDT 1.21 (DAT200 Asset Vision Basic).

Other tool/system integrations (e.g., Emerson AMS/Siemens S7) are available upon request.

A free of charge version of the DAT200 Asset Vision Basic framework application for HART® is available upon request.

The required DTMs are contained on the DAT200 Asset Vision Basic DVD or in the DTM Library. They can also be downloaded from www.abb.com/flow.

Connection examples for peripherals (incl. HART)

Current output

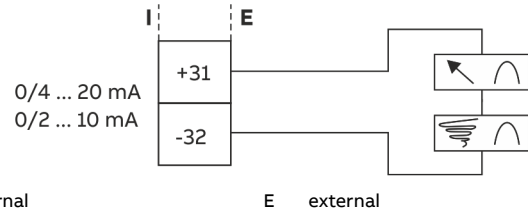

I internal E external

Figure 36: Current output active with / without HART protocol (4 ... 20 mA)

Current output active with / without HART protocol (4 ... 20 mA)

Terminals	31, 32
Current output	can be selected via software
Function	Active
	0/4 ... 20 mA ($0 \Omega \leq R_B \leq 560 \Omega$)
	0/2 ... 10 mA ($0 \Omega \leq R_B \leq 1120 \Omega$)
	(for HART only 4 ... 20 mA)

Switch output

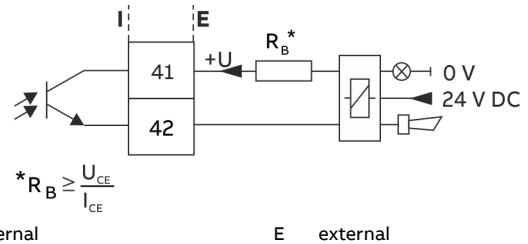

I internal E external

Figure 37: Switch output for system monitoring, Max. / Min. alarm for empty meter tube or forward / reverse signal

Switch output for system monitoring

Terminals	41, 42
Current output	can be selected via software
Function	Passive
	• 'closed': $0 V \leq U_{CEL} \leq 2 V, 2 mA \leq I_{CEL} \leq 220 mA$
	• 'open': $16 V \leq U_{CEH} \leq 30 V, 0 mA \leq I_{CEH} \leq 2 mA$

Note

Horn and alarm light are shown only as examples. Other suitable devices such as bells, sirens, buzzers, etc., can also be used.

7 Commissioning

Safety instructions

CAUTION

Risk of burns due to hot measuring media

The device surface temperature may exceed 70 °C (158 °F), depending on the measuring medium temperature!

- Before starting work on the device, make sure that it has cooled sufficiently.

Aggressive or corrosive media may lead to the damage of wetted parts of the sensor. As a result, measuring medium under pressure can leak out.

Wear to the flange gasket or process connection gaskets (e.g. pipe fitting, Tri-clamp, etc.) may caused a pressurized measuring medium to escape.

When using internal flat gaskets, they can become brittle through CIP- / SIP processes.

If pressure surges above the permissible nominal pressure of the device occur permanently during operation, this may affect the service life of the device.

If there is a chance that safe operation is no longer possible, take the device out of operation and secure it against unintended startup.

Checks before commissioning

The following points must be checked before commissioning:

- The power supply must be switched off.
- The power supply used must match the information on the name plate.
- The terminal assignment must be made in accordance with the electrical connection.
- Sensor and transmitter must be grounded properly.
- The temperature limit values must be observed.
- When the sensor (SE41F, SE21, SE21F) and transmitter (S4) are delivered as a pair, the data memory module (external FRAM) is located in the sensor. The data module stores the sensor data, e.g., size, Cs, Cz, type, etc., as well as the setup data on the transmitter after commissioning.
- Prior to commissioning, plug the external FRAM for the appropriate sensor (order no. is printed on the FRAM and, if available, a TAG no.) to the terminal board for the installed transmitter. Then screw to the connection board (captive).

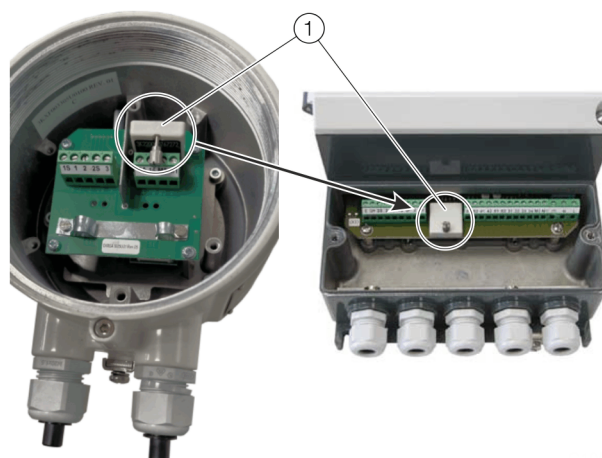

① External FRAM

Figure 40: Plugging the FRAM into the transmitter

Note

If a transmitter is ordered for an older model sensor (see model number), an external FRAM is already connected to the connection board. You will also find the information $C_s = 100\%$ and $C_z = 0\%$, which is required for flowmeters primary from older product lines. In this regard, see also **Additional information regarding use of enhanced diagnostic functions** on page 82.

- The transmitter must be installed at a location largely free of vibrations.
- Monitoring of pulse output.
The pulse output can be operated as active output (24 VDC pulse) or as passive output (optocoupler). The current setting is provided on the name plate for the transmitter. Modification as shown in the following illustration.

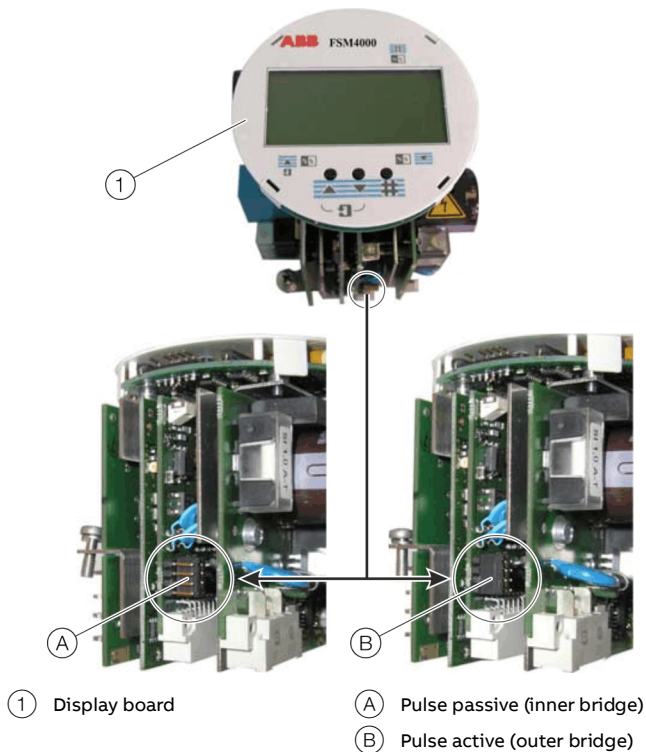

Figure 41: Setting the pulse output using jumpers

Commissioning**Power Supply Power-Up**

After switching on the power supply, the sensor data in the external FRAM is compared with the data saved internally. If the data is not identical, the transmitter data is replaced automatically. Once completed, Warning 7 'Sensor data loaded' and Warning 8b 'Update external FRAM' are displayed. The measuring equipment is now ready for operation. The display shows the current flowrate.

... 7 Commissioning

... Commissioning

Device configuration

The device can be factory calibrated to customer specifications upon request. If no customer information is available, the device is delivered with factory settings.

On-site configuration requires only a few parameter settings. For entry or selection of parameters, refer to the section titled 'Entering data in short form'. A short overview of the menu structure can be found in the section titled 'Parameter overview'. The Easy Set-up menu enables users to configure the unit quickly and conveniently, see **Easy Set-up, for uncomplicated parameterization** on page 43.

The following parameters should be checked or set for commissioning:

1. **Upper range value** (menu item 'Q_{max}' and menu item 'Unit').
The device is factory calibrated to the largest flow range end value, unless customer information to the contrary is available. Upper range values that correspond to a flow velocity of 2 to 3 m/s are ideal. First set the unit Q_{max} (e.g. m³/h oder l/s) in the menu item 'Unit' and then the upper range value in menu item 'Q_{max}'. The smallest and largest possible upper range values are shown in Table **Measuring range table** on page 24.
2. **Current output** (menu item 'Current output')
Selected the desired current range here (0 to 20 mA or 4 to 20 mA)
3. For devices with a fieldbus, the bus address must be set (menu item 'Interface').
4. **Pulse output** (menu items 'Pulse' and 'Unit').
To set the number of pulses per volume flow unit, a unit for the totalizer (e.g., m³ or l) must be selected in the menu item 'Unit'. Afterward the number of pulses has to be entered in the menu item 'Pulse output'.
5. **Pulse width** (menu item 'pulse output')
For external processing of the counting pulses at terminals 51 and 52, the pulse width can be set between 0.1 ms and 2000 ms.
6. **System zero point** (menu item 'Syst.-Adjust')
When commissioning an older model flowmeter sensor or checking the system, you can set the system zero point on the transmitter after a warmup period. The fluid in the flowmeter sensor must be at absolute standstill. The measuring tube must be completely full. The adjustment can now be made manually or automatically on the transmitter via the 'System zero point' parameter. Select the parameter by pressing ENTER, use the arrow buttons for example to call up 'automatic' and press ENTER again to start the adjustment. The adjustment runs approx. 60 seconds and should be within a range of ± 10%. If the value measured is outside this limit, no calibration is performed. The adjustment can also be performed via the external switch input / ext. sys. zero point (see parameter **Switch input** on page 64).
7. **Detector empty pipe**
(Menu item 'Detector e. pipe'), for devices with nominal diameter DN 10 and/or without preamplifier.
When the 'Standard' DEP mode is selected, you do not need to perform an adjustment on site. The transmitter works with standard setup data. If the function is not performed correctly, a new adjustment must be run with the fluid onsite. The adjustment can be made with a full or empty meter pipe.
8. **Extended diagnostic functions**
To measure the DC resistance or the coil temperature, the signal cable length must be entered. To use the functions Electrode voltage, Electrode balance and Electrode state, the electrode zero must be adjusted. See submenu **Adjustment** on page 78 or **Additional information regarding use of enhanced diagnostic functions** on page 82.

Note

If the flow indicator shows the incorrect flow direction after successful commissioning of the measuring system, e.g., reverse instead of forward, correct this in the 'Operating mode submenu' of the transmitter.

First switch off the programming protection ('Prog. Level' → 'Specialist'). Then select the parameter 'Directional display' in the 'Operating mode submenu' and change 'normal' to 'inverse'. Finally, reactivate programming protection by selecting 'Prog. Level' → 'Locked').

Easy Set-up, for uncomplicated parameterization



The Easy Set-up function enables users to configure the transmitter for quick and convenient startup. For further setup options, see **Parameter descriptions** on page 47.

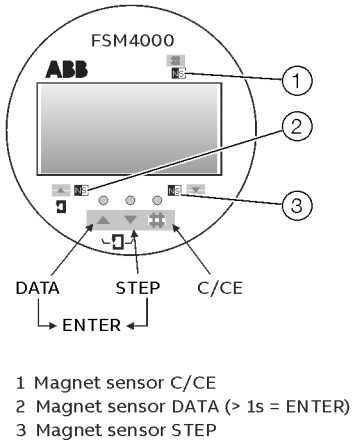

Press any key in the process display, then use STEP or DATA to scroll to the "Easy Set-up" menu.

Note!
 Parameters can be changed only when the Program protection is turned off.

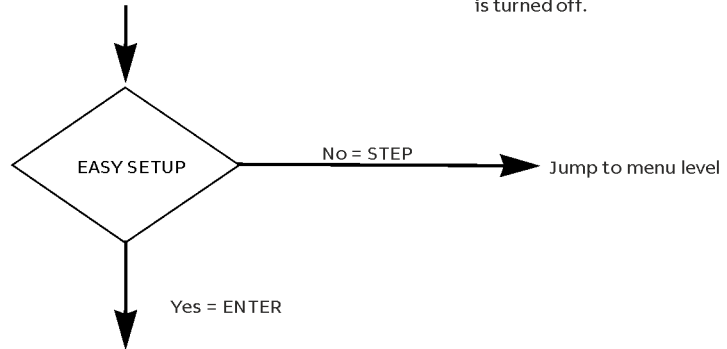

Language
English

Unit Qmax
l/s

Unit totalizer
m3

Qmax
50.000 l/s

Damping 1 Tau
0.22 sek

Display mode
4 small

Display 1st line
Q [Unit]

Display 2nd line
Totalizer → V

Display 3rd line
Totalizer ← R

"Easy Set-up" finished.
 Jump back to the process display or use STEP to go to the menu level.

Pulse width
0.1000 ms

Pulse factor
1/m3

Iout High Alarm
23.000 mA

Iout Low Alarm
3.6 mA

Iout at Alarm
High Alarm

Display 4th line
Q [m/s]

Within "Easy Set-up", call up the next parameter using the C/CE key. Change the parameter using the "Enter" function.



Figure 42: Easy Set-up function

8 Operation

Safety instructions

CAUTION

Risk of burns due to hot measuring media

The device surface temperature may exceed 70 °C (158 °F), depending on the measuring medium temperature!

- Before starting work on the device, make sure that it has cooled sufficiently.

Aggressive or corrosive media may lead to the damage of wetted parts of the sensor. As a result, measuring medium under pressure can leak out.

Wear to the flange gasket or process connection gaskets (e.g. pipe fitting, Tri-clamp, etc.) may caused a pressurized measuring medium to escape.

When using internal flat gaskets, they can become brittle through CIP- / SIP processes.

If pressure surges above the permissible nominal pressure of the device occur permanently during operation, this may affect the service life of the device.

If there is a chance that safe operation is no longer possible, take the device out of operation and secure it against unintended startup.

Display options

After switching on the power supply, the current process information for the measuring point is displayed.

In the first line of the display, the current flow direction (→ F for forward, ← R for reverse) is displayed along with the flowrate as a percentage or a physical unit. The second line of the display shows the totalizer value (7-digit) for the current flow direction, followed by the relevant unit.

Independent of the pulse factor, the totalizer value is always the current flowrate with relevant unit. This indicator is displayed in the following text as process information.

The 4 lines of the display can be customized in the 'Display' submenu.

Examples:

→ v 98.14 l/h	1. line	Current upstream flow rate
→ v 12.30000 m ³	2. line	Totalizer value, forward
← R 516.0000 m ³	3. line	Totalizer value, reverse (multiplex mode)

Totalizer overflow always occurs at a value of 9,999,999 units. If the totalizer value for a flow direction is larger than 9,999,999 units, Warning 9 is displayed in the 4th line. The totalizer software can register up to 250 overflows. The overflow notification can be cleared in the Totalizer submenu by using the 'Reset totalizer' function.

Error condition

In the event of an error, an error or warning message is displayed in the 4th display line.

Flow rate > 103 %

This message is displayed alternatively in plain text and with the relevant error or warning number. The plain text error message provides the error or warning with the highest priority only. However, all existing errors and warnings are shown in the number display.

For a list of all possible error messages, refer to the chapter 'Error messages'.

In addition to the error message, the current output is set to the limit value (menu 'lout for alarm'). The alarm can be indicated optionally via the switch output, if selected.

Note

Error messages for 'enhanced diagnosis' are only indicated on the display or optionally via the switch output (select 'General Alarm' or 'ext. Diag. Alarm").

Data entry

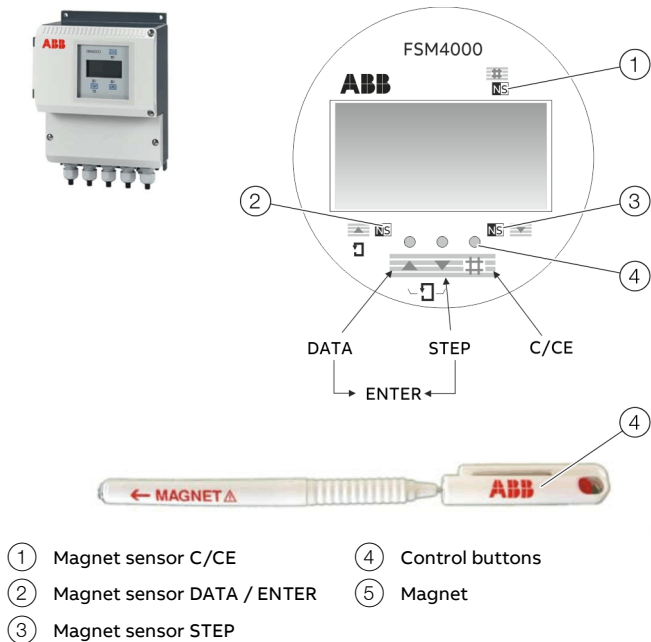

- ① Magnet sensor C/CE
- ② Magnet sensor DATA / ENTER
- ③ Magnet sensor STEP
- ④ Control buttons
- ⑤ Magnet

Figure 43: Controls on the transmitter

Use the buttons ④ to enter data when housing is open. If the housing cover is closed, use the magnet stick ⑤ and the magnet sensors. The stick is held over the appropriate NS symbol.

When entering data, the transmitter remains online, i.e., current and pulse outputs still show the current operating mode.

The functions of the individual keys are explained below:

	C/CE	Toggle between operating mode and menu.
	STEP ↓	The STEP key is one of two arrow keys. Use STEP to scroll forward through the menu. All the required parameters can be called up.
	DATA ↑	The DATA key is one of two arrow keys. Use DATA to scroll backward through the menu. All the required parameters can be called up.
	ENTER	<p>The ENTER function requires that both arrow keys, STEP and DATA, be pressed simultaneously. ENTER has the following functions:</p> <ul style="list-style-type: none"> • Access the parameter to be changed and set the new, selected, or default parameter. <p>The ENTER function is effective for approx. 10 s only. If a new value is not entered within 10 s, the display reverts to the old value.</p>

Initiating the ENTER function when using the magnet stick for operation

The ENTER function is initiated when the DATA/ENTER sensor is activated for longer than 3 seconds. The display flashes to indicate that the function is active.

There are two different methods of entering data:

- Numerical entry
- Entry from specified table

Note

When entering data, the values are checked for plausibility and, if necessary, rejected with an appropriate message. In addition, in the 3th and 4th line, the limit values (min/max) are displayed.

... 8 Operation

... Data entry

Entering data in short form

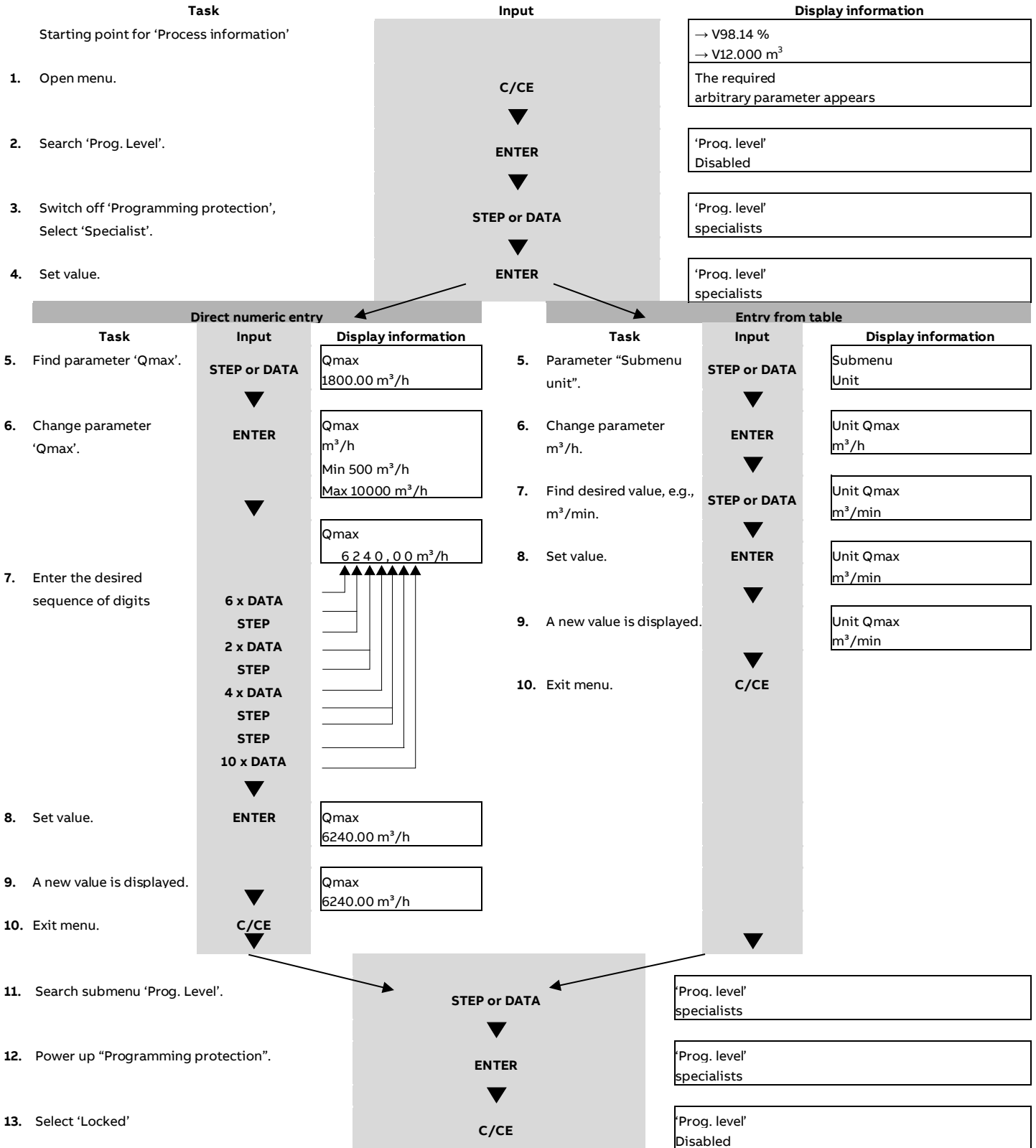

Parameter descriptions

Submenu / parameter	Value range	Remark
<pre> graph TD Root["Prog.Level Disabled"] --- L1_1["Prog. level Disabled"] Root --- L1_2["Prog. level Standard"] Root --- L1_3["Prog. level specialists"] Root --- L1_4["Prog. level Service"] L1_4 --- L2_1["Service code? 0"] L1_4 --- L2_2["Prog. level Prog. prot. code"] L2_2 --- L3_1["Old PP code: 0"] L2_2 --- L3_2["New PP code 0"] </pre>	<p>1 ... 9999</p> <p>1 ... 9999</p>	<p>“Locked”: All entries in the standard menus can be read</p> <p>“Standard” menus are shaded in gray</p> <p>“Standard”: Menu with all menu items needed to operate the device.</p> <p>‘Specialist’: Specialist menu with all menu items accessible by the customer.</p> <p>“Service”: Additional service menus can be displayed by entering the correct service code number (for ABB Service personnel only).</p> <p>The Prog. Protection Code is normally ‘0’. If Prog. Protection is selected, the question ‘New PP code?’ is displayed. If the user enters an incorrect code between 1 ... 9999, a message **Prog.Prot.** appears, indicating that the menu is locked and requires the correct PP code. To suspend the PP-Code function, you must access the ‘PP-Code’ menu. Select ENTER and you will be asked for the old PP code. You must enter the correct old code before the message ‘New PP-Code?’ is displayed. Enter a new code or select ‘0’ to disable the PP-Code function.</p>

... 8 Operation

... Parameter descriptions

Submenu / parameter	Value range	Remark
<div style="border: 1px solid black; padding: 2px; display: inline-block;">Submenu EASY SETUP</div> <div style="margin-left: 20px; border: 1px solid black; padding: 2px; display: inline-block;">EASY SETUP</div>	Language Unit Qmax Unit totalizer Qmax Damping 1,000 Display mode Display line 1 Display line 2 Display line 3 Display line 4 Iout for alarm Low Alarm High alarm Pulse factor Vol. Pulse width	The EASY SETUP function allows you to configure the measuring system in an easy manner for operation. Menus are displayed in sequential order by EASY SETUP. If the display mode 1 big, 1 small is selected, the selection menus for Display 3rd line and Display 4th line are not displayed. For HART devices, the selection menu 'Iout type' is also not displayed. The ENTER function allows you to change parameters; the C/CE button jumps to the next entry. Press ENTER again to change parameters and, if necessary, you can call the next parameter via the STEP button. For numeric entries, the minimum and maximum settings are displayed.
<div style="border: 1px solid black; padding: 2px; display: inline-block;">Language German</div> <div style="margin-left: 20px; border: 1px solid black; padding: 2px; display: inline-block;">Language German</div>	German English French Finnish Spanish Italian Dutch Danish Swedish Turkish	The languages available are displayed in the present language selection. Menus in the Service Code section are displayed in English.
<div style="border: 1px solid black; padding: 2px; display: inline-block;">Submenu Operating mode</div> <div style="margin-left: 20px; border: 1px solid black; padding: 2px; display: inline-block;">Operating mode Normal</div>	Normal Fast Piston Pump	"Normal": Selection used for continuous flow measurement. "Quick": Accelerated data processing (e.g., short batch time dosing). "Piston pump": For pulsating flows. In this operating mode, data logging improves reproducibility for pulsating flows and during pump operation. The totalizer is automatically set to the difference totalizer operating mode. Any possible re-flow is automatically deducted from the totalizer count.
<div style="border: 1px solid black; padding: 2px; display: inline-block;">Directional display Normal</div>	Standard, inverse	Standard/inverse, change the flow direction indicators in the display for forward and reverse flow.

Submenu / parameter	Value range	Remark
Flow direction Forward/reverse flow	Supply/Return Forward	When the flow direction 'Forward/reverse flow' is selected, the flow direction is indicated in the display with '→ V' for forward and '← R' for reverse. If the forward flow setting is selected, the totalizer counts the forward flow only. If the flow is reversed, warning 10 'Reverse flow Q' is displayed.
Noise reduction Off	Off, 1, 2, 3, 4	The noise reduction is switched on when the flow rate signal is: <ul style="list-style-type: none"> - very unstable or - temporarily or permanently frozen (error E) Notice: Activating noise reduction increases the response time.
Submenu Unit		
Unit totalizer ml	ml; l; m3; ugl; igl; bbl; g; kg; t; lb; prog unit ¹⁾ ; ft ^{3 2)}	Select the engineering units for volume and mass flowrate totalization. If the physical units are changed, the transmitter checks and changes the pulse factor and pulse width (0.1 ms to 2000 ms) depending on the measuring range. The transmitter first changes the pulse factor and then the pulse width. 1) kgal = Factory setting
Unit Qmax l/s	l/s; l/min; l/h; m3/s; m3/min; m3/h; m3/d; usgps; usgpm; usgph; usmgd; igps; igpm; igph; igpd; bbl/s; bbl/m; bbl/h; bbl/d; g/s; g/min, g/h; kg/s;kg/min; kg/h; kg/d; t/min; t/h; t/d; lb/s; lb/min; lb/h; lb/d; ml/s, ml/min Prog. Unit/s1) Prog. Unit/min1) Prog. Unit/h1) Prog. Unit/d1)	Select the unit for volume and mass flow. This unit refers to Qmax DN, Qmax and the instantaneous status, if these are displayed in physical units. 1) kgal = Factory setting

... 8 Operation

... Parameter descriptions

Submenu / parameter	Value range	Remark
Submenu Prog. Unit		
Unit name kgal	Text entry	Four character name for the user programmable unit. kgal = Factory setting.
Units factor 3785.1	Numerical entry	Reference factor for the user-defined units based on liters; default value in kgal units (factory setting).
Prog. Unit Without density	Without density With density	Unit for mass (with density) or volume (without density).
Density 1 g/cm ³	Numerical entry	Density range 0.1 ... -5 g/cm ³ . Mass flowrate for display and totalization. The density is only considered when mass flow units are and/or totalizer mass units are selected.
Submenu System data		
Submenu Transmitter		
Submenu Data 50 Hz		This menu does not appear with an excitation frequency of 60 Hz or 70 Hz. Only for old (legacy) sensors.
Channel -123 μs	View only	Adjustment value for Channel can be monitored for the excitation frequency setting (displayed when an older primary 50 Hz has been selected).
Zero 0 %	View only	Adjustment value for zero point can be monitored to check the excitation frequency setting (displayed when an older 50 Hz sensor has been selected).
Voltage → V 91 %	View only	Adjustment value for Span Forward can be monitored for the excitation frequency setting (displayed when an older primary 50 Hz has been selected).
Voltage ← R -91 %	View only	Adjustment value for Span Reverse can be monitored for the excitation frequency setting (displayed when an older primary 50 Hz has been selected).

Submenu / parameter	Value range	Remark
<div style="border: 1px solid black; padding: 2px; width: fit-content;"> Submenu Data 60 Hz </div>		This menu does not appear with an excitation frequency of 50 Hz or 70 Hz. Only for old (legacy) sensors.
<div style="border: 1px solid black; padding: 2px; width: fit-content;"> Channel -123 μs </div>	View only	Adjustment value for channel can be monitored to check the excitation frequency setting (displayed when an older 60 Hz sensor has been selected).
<div style="border: 1px solid black; padding: 2px; width: fit-content;"> Zero 0 % </div>	View only	Adjustment value for zero point can be monitored to check the excitation frequency setting (displayed when an older 60 Hz sensor has been selected).
<div style="border: 1px solid black; padding: 2px; width: fit-content;"> Voltage → V 91 % </div>	View only	Adjustment value for Span Forward can be monitored to check the excitation frequency setting (displayed when an older 60 Hz sensor has been selected).
<div style="border: 1px solid black; padding: 2px; width: fit-content;"> Voltage ← R -91 % </div>	View only	Adjustment value for Span Reverse can be monitored to check the excitation frequency setting (displayed when an older 60 Hz sensor has been selected).

... 8 Operation

... Parameter descriptions

Submenu / parameter	Value range	Remark
<div style="border: 1px solid black; padding: 2px; width: fit-content;">Submenu Data 70 Hz</div>		This menu does not appear with an excitation frequency of 50 Hz or 60 Hz. Only for SE41F and SE21 transmitters.
<div style="border: 1px solid black; padding: 2px; width: fit-content;">Channel -123 μs</div>	View only	Display of the phase deviation between signal and reference voltage in μ s.
<div style="border: 1px solid black; padding: 2px; width: fit-content;">Zero Span >V Span <R</div>	View only	Display of the adjustment values for zero point, span forward and span reverse when amplification 'High' is selected in the 'Service / Primary Adjust / Amplification' menu.
<div style="border: 1px solid black; padding: 2px; width: fit-content;">Zero_2 Span 2 >V Span 2 <R</div>	View only	Display of the adjustment values for zero point, span forward and span reverse when amplification 'Middle High' is selected in the 'Service / Primary Adjust / Amplification' menu.
<div style="border: 1px solid black; padding: 2px; width: fit-content;">Zero_4 Span 4 >V Span 4 <R</div>	View only	Display of the adjustment values for zero point, span forward and span reverse when amplification 'Middle Low' is selected in the 'Service / Primary Adjust / Amplification' menu.
<div style="border: 1px solid black; padding: 2px; width: fit-content;">Zero_8 Span 8 >V Span 8 <R</div>	View only	Display of the adjustment values for zero point, span forward and span reverse when amplification 'Low' is selected in the 'Service / Primary Adjust / Amplification' menu.
<div style="border: 1px solid black; padding: 2px; width: fit-content;">Zero_Pre/FIR</div>	View only	Display of the zero point offset with activated filter in 'Service / Noise Handling / Prefilter /' and 'Service / Noise Handling / Prefilter / FIR EA'
<div style="border: 1px solid black; padding: 2px; width: fit-content;">Zero_Pre</div>	View only	Display of the zero point offset with activated filter in 'Service / Noise Handling / Prefilter /'

Submenu / parameter	Value range	Remark
<div style="border: 1px solid black; padding: 2px; margin-bottom: 5px;"> Submenu Data lout </div> <div style="border: 1px solid black; padding: 2px; margin-left: 20px; margin-bottom: 5px;"> Adjust lout 4 mA 4.0 mA </div> <div style="border: 1px solid black; padding: 2px; margin-left: 20px; margin-bottom: 5px;"> Adjust lout 4 mA 20.0 mA </div> <div style="border: 1px solid black; padding: 2px; margin-left: 20px; margin-bottom: 5px;"> Submenu Flowmeter sensor </div> <div style="border: 1px solid black; padding: 2px; margin-left: 20px; margin-bottom: 5px;"> Sensor model DS2_, DS4 </div> <div style="border: 1px solid black; padding: 2px; margin-left: 20px;"> Line frequency 50 Hz </div>	<p>View only</p> <p>View only</p> <p>View only</p>	<p>Display adjustment value for transmitter for the current output at 4.0 mA.</p> <p>Display adjustment value for transmitter for the current output at 20.0 mA.</p> <p>Display the connected flowmeter model: The selection is imported with the FRAM automatically by the transmitter. If an older flowmeter sensor model (see list) is selected, the FRAM with Cs = 100%, Cz = 100% must be used. The models 10D1422 (10DI1425, 10DS3111A-C ≥ DN 500) can only be connected to a specially designed terminal board on the transmitter. Close switch S903 on the connection board. The other models are put into operation with their assigned FRAM. For this reason, when older model flowmeter sensors are connected to the transmitter, a 'Primary Setup' menu is displayed at initial startup. Additional settings can be entered in the system data submenu 'Primary'. See also S4 operation with older sensor on page 93.</p> <p>Display the mains frequency for which the flowmeter sensor was calibrated. Displayed only for 50/60 Hz older models. Not displayed, if SE41F or SE21 sensor is selected.</p>

... 8 Operation

... Parameter descriptions

Submenu / parameter	Value range	Remark
<div style="border: 1px solid black; padding: 2px;"> Nominal diameter 1 mm 1/25 in </div>	View only 1 mm 1/25 in 1.5 mm 1/17 in 2 mm 1/12 in 3 mm 1/10 in 4 mm 5/32 in 6 mm 1/4 in 8 mm 5/16 in 10 mm 3/8 in 15 mm 1/2 in 20 mm 3/4 in 25 mm 1 in 32 mm 1-1/4 in 40 mm 1-1/2 in 50 mm 2 in 65 mm 2-1/2 in 80 mm 3 in 100 mm 4 in 125 mm 5 in 150 mm 6 in 200 mm 8 in 250 mm 10 in 300 mm 12 in 350 mm 14 in 400 mm 16 in 450 mm 18 in 500 mm 20 in 600 mm 24 in 700 mm 28 in 750 mm 30 in 800 mm 32 in 900 mm 36 in 1000 mm 40 in	Display the flowmeter sensor size. Not displayed, if no flowmeter sensor type is selected (flowmeter sensor type = none).

Submenu / parameter	Value range	Remark
Span Cs 100.0 %	View only	Flowmeter sensor span value Cs.
Zero Cz 0.0 %	View only	Flowmeter sensor zero value Cz. For old sensor always 0 %.
Phase 90	View only	Phase relationship between reference and signal voltages. For SE41F and SE21 transmitters always 90°.
Reference voltage 70 mV	View only	Display the reference voltage, for 'Older Model' selection. Not displayed for model 10D1422.
Meter factor 1.0	View only	Displayed only if flowmeter sensor 10D1462/72 is selected
Order no. '.....'	View only	Display the ABB order number for the flowmeter sensor.
Submenu Primary Setup	Option available only with 'Older sensor'	Menu required for older sensors only. Visible only if 50 or 60 Hz has been selected in the 'Service/Primary Adjust/Frequency Primary' menu. By selecting 'Yes', the primary setting is started and the user is guided in a similar manner as for the 'Easy Set-Up' direction.
Line frequency 50 Hz	50, 60 Hz	Displays the mains frequency for the flowmeter sensor. Option available only with 'Older sensor'.
Sensor model DS4_	Selection of the older sensor	Display the connected flowmeter sensor model:
Nominal diameter 100 mm 4 in	Select the size of the connected flowmeter sensor	Select the size of the flowmeter sensor. Option available only with 'Older sensor'.
Reference voltage 70 mV	Enter the reference voltage	Display the reference voltage, only for 'Older sensor' option, see name plate for sensor. Not displayed for models 10D1422, 10D1462/72.
Meter factor 1.0	Numerical entry	Display the meter factor, only for older model 10D1462/72; see name plate for flowmeter sensor. See also S4 operation with older sensor on page 93.

... 8 Operation

... Parameter descriptions

Submenu / parameter	Value range	Remark
Qmax DN 50 m ³ /h	View only	Display the max. possible flow range. Automatically selected based on size.
Qmax 50 m ³ /h	Numerical entry	Flow range end value for forward and reverse flow. Flow range end value configurable from 0.5 ... 10 m/s.
Damping 1τ 1 sec	Numerical entry	Response time, after 1τ the value displayed has reached 63% of its end value (after 5τ). The following values can be selected, operating mode: Standard 0.2 ... 20 s, Quick/piston pump 0.07 ... 20 s.
Low flow 1.0 %	Numeric entry 0 ... 10% of Qmax	Applicable for display and all outputs. The switching limit for the low flow cutoff has a built-in hysteresis of 0.1%.
Submenu Detector e. pipe		<p>Note</p> <p>The meter pipe must be completely filled to ensure proper measurement. The function 'Detector empty pipe' can be used to continuously monitor this condition. If the measuring medium drops below the electrode level, all output signals can be automatically set to zero. This ensures false pulses or incorrect displays are avoided when the meter pipe is empty. In addition to the message in the display, this condition can be reported via the switch contact output. If the meter tube is filled, the error message 'empty pipe' is turned off and the measuring system returns to normal operation.</p>
Detector e. pipe Off	Off A	<p>Turn on/off the 'Detector empty pipe' function. Not configurable for sizes:</p> <p>1 mm 1/25 in 1.5 mm 1/17 in 2 mm 1/12 in 3 mm 1/10 in 4 mm 5/32 in 6 mm 1/4 in 8 mm 5/16 in</p> <p>Note</p> <p>The 'empty pipe' function is not available for flowmeter sensors with preamplifiers. The menu is hidden.</p>

Submenu / parameter	Value range	Remark
<div style="border: 1px solid black; padding: 2px; width: fit-content;">DLR Mode Standard</div>	Standard New adjustment	Selection of operating mode for empty tube detection. <ul style="list-style-type: none"> • Standard: Factory adjustment to water, appropriate for most measuring media. • New adjustment: Start new adjustment to the current medium. <p>Note During adjustment, the pipe must be empty and fill afterwards. Not displayed, if DEP is switched off.</p>
<div style="border: 1px solid black; padding: 2px; width: fit-content;">Adj. DLR empty 1000</div>	Manual Automatic	Menu visible when 'New adjustment' is selected in the 'DLR Mode' parameter. Adjustment value for empty meter pipe. The pipeline must be empty. <ul style="list-style-type: none"> • Automatic: Start the empty tube adjustment. After the adjustment is completed, the transmitter displays the adjustment value in the bottom line. • Manual: Fine adjustment of the automatically determined adjustment value. Not displayed, if DEP is switched off or DEP mode is standard.
<div style="border: 1px solid black; padding: 2px; width: fit-content;">Adj. DLR full 500</div>	Manual Automatic	Menu visible when 'New adjustment' is selected in the 'DLR Mode' parameter. Adjustment value for full meter pipe. The piping must be completely filled. <ul style="list-style-type: none"> • Automatic: Start the adjustment. After the adjustment is completed, the transmitter displays the adjustment value in the bottom line. • Manual: Fine adjustment of the automatically determined adjustment value. Not displayed, if DEP is switched off or DEP mode is standard.

... 8 Operation

... Parameter descriptions

Submenu / parameter	Value range	Remark
<div style="border: 1px solid black; padding: 2px; width: fit-content;">Switching threshold 100000</div>	Numerical entry	<p>Menu visible when 'New adjustment' is selected in the 'DLR Mode' parameter. Switching threshold for turning off the 'Empty pipe' function. The switching threshold is calculated by the transmitter from both values 'Adj. DLR empty' and 'Adj. DLR full'.</p> <p>The calculated value can be changed here for fine adjustment in the range from 100 to 1000000.</p> <p>Not displayed, if DEP is switched off or DEP mode is standard.</p>
<div style="border: 1px solid black; padding: 2px; width: fit-content;">Alarm e. pipe: Off</div>	Off A	<p>If the alarm is switched on, the empty pipe contact is actuated when the pipe empties. The 'empty pipe' or 'General alarm' switch output must be selected in the 'Switch contacts' submenu. When the function is turned off, the alarm does not respond.</p> <p>Not displayed, if DEP is switched off.</p>
<div style="border: 1px solid black; padding: 2px; width: fit-content;">Iout for e. pipe Low Alarm</div>	Low Alarm High alarm 0 %	<p>Set the current output value to Low or High in event of error.</p> <p>Not displayed, if DEP is switched off.</p>

Submenu / parameter	Value range	Remark
<div style="border: 1px solid black; padding: 2px; margin-bottom: 10px;"> Submenu Display </div> <div style="border: 1px solid black; padding: 2px; margin-bottom: 10px;"> Display mode 1 big, 1 small </div> <div style="border: 1px solid black; padding: 2px;"> Display 1st line Q [Percent] </div>	<p>1 big, 1 small, 4 small</p> <p>Q [percent]; Q [Unit]; Iout [mA]; Q [m/s]; Q BargraphTotalizer; Totalizer → V; Totalizer ← R; Totalizer Diff.; HART TAGDetector I.pipe Blank line Additional selection for extended diagnosis: Fprt1; Fprt2; Fprt3; Fprt4; Hist Max Error; Hist Min Error; Curr Max Error; Curr Min Error; Curr Max Warn; Curr Min Warn; Wiring. Warning; Wiring Failure</p>	<p>Select each different line displayed for the process indicators in this submenu. You can also adapt the contrast of the display to local conditions by pressing the arrow keys.</p> <p>Select 1 big and 1 small line or 4 small lines.</p> <p>Selection of 1st display line Notes regarding the measured values Fprt1 to Fprt4 (assignment of measured values in the submenu Diagnosis / Fingerprint) as well as the diagnosis error register, see Additional information regarding use of enhanced diagnostic functions on page 82.</p>

... 8 Operation

... Parameter descriptions

Submenu / parameter	Value range	Remark
Display 1st line All Auto GOOD0		Displays the current mode for the function blocks.
Display 2nd line Q [Percent]	Like display 1st line	Selection of 2nd display line
Display 3rd line Q [Percent]	Like display 1st line	Option unavailable if 1 big, 1 small is selected for the display mode
Display 4th line Q [Percent]	Like display 1st line	Option unavailable if 1 big, 1 small is selected for the display mode
Contrast		Set the contrast for the display to adjust to local conditions, STEP = darker; DATA = lighter. Note Adjust the contrast so that the display remains readable.

Submenu / parameter	Value range	Remark
<div style="border: 1px solid black; padding: 2px; margin-bottom: 10px;">Submenu Alarm</div> <div style="margin-left: 20px;"> <div style="border: 1px solid black; padding: 2px; margin-bottom: 10px;">Min. alarm 0 %</div> <div style="border: 1px solid black; padding: 2px;">Max. alarm 100 %</div> </div>	<p>Numerical entry 0% – Max. Alarm</p> <p>Numerical entry Min. Alarm – 103%</p>	<p>Range limit for the Min. Alarm 0% – Max. Alarm of configured measuring range. Configurable in 1% increments, 1% switching hysteresis.</p> <p>Range limit for the Max. Alarm Min. Alarm – 103% of configured measuring range. Configurable in 1% increments, 1% switching hysteresis.</p>
<div style="border: 1px solid black; padding: 2px; margin-bottom: 10px;">Submenu Counter</div> <div style="margin-left: 20px;"> <div style="border: 1px solid black; padding: 2px;">Overflow → F 0</div> </div>	<p>Read only</p>	<p>The totalizer function is set automatically in the 'Operating mode' submenu. Standard operating mode = standard totalizer function, Piston pump operating mode = Totalizer function Diff. totalizer.</p> <p>Standard = For the standard totalizer function, the counting pulse for forward and reverse flow is registered on two separate totalizers. If Forward is selected as flow direction, only the forwards totalizer counts.</p> <p>Diff. totalizer = For differential count, a shared totalizer is used for both flow directions. For the forward flow direction, the pulses are added, for the reverse flow direction, they are subtracted. If the totalizer count is negative, i.e. the reverse flow amount is greater than the forward flow amount, the direction indicator on the display changes from "F" to "R". The pulse output (active or passive) is not affected by this setting.</p> <p>Overflow totalizer max. 65535. 1 overflow = pulse totalizer 9,999,999 units. Resets the display status and increments the overflow counter by one. Overflow example: Overflow 012 12 x 10,000,000 units = 120,000,000 units + 23,455 current totalizer value results in a total of 120,023,455 units</p>

... 8 Operation

... Parameter descriptions

Submenu / parameter	Value range	Remark
Totalizer → F 0.0 kg/h	Numerical entry 0 ... 9999999	Display or input the forward totalizer value.
Overflow ← R 0	Read only	Overflow totalizer max. 65535. 1 overflow = pulse totalizer 9,999,999 units. Resets the display status and increments the overflow counter by one.
Totalizer ← R 0	Numerical entry 0 ... 9999999	Display or input the reverse flow totalizer value.
Reset totalizer		Select ENTER to reset the forward/reverse flow totalizer and overflow counters.
Overflow Diff. 0	Read only	Display the overflow for the diff. totalizer.
Totalizer Diff. 0.0 kg/h	Numerical entry 0 ... 9999999	Display or input the diff. totalizer value.
Submenu Current output		
Current output 0 - 20 mA	0 - 20 mA, 4 - 20 mA 0 - 10 mA, 2 - 10 mA	Select the current output range. For HART protocol always 4 - 20 mA.
Iout for alarm Low Alarm	Low Alarm High alarm	Behavior of the current output during an alarm. Low-Alarm is available only for current output of 2 - 10 mA and 4 - 20 mA. If error 0 (empty tube) occurs, the current output is set to the value programmed for the parameter 'Iout during empty tube' in the submenu 'Detector empty tube'. If error 3 (flow rate > 103 %) occurs, 'High Alarm' is always signaled.
Iout low alarm 3.60 mA	Numerical entry	Low-Alarm is available only for current output of 2 - 10 mA or 4 - 20 mA. Set the current output value during Low Alarm condition. No selection available if High Alarm is selected for the current output selection for Iout during alarm and if the transmitter version is standard and the current output range is 0 - 20 mA 0 - 10 mA .

Submenu / parameter	Value range	Remark
<div style="border: 1px solid black; padding: 2px; width: fit-content; margin-bottom: 5px;"> Submenu Pulse output </div> <div style="border: 1px solid black; padding: 2px; margin-bottom: 5px;"> Iout high Alarm 21.80 mA </div>	Numerical entry	Set the current output value during High Alarm condition. If error 3 (flow rate > 103 %) occurs, 'High Alarm' is always signaled. No selection available for current output if Low Alarm is selected for Iout during Alarm.
<div style="border: 1px solid black; padding: 2px; margin-bottom: 5px;"> Error 3 mask Off </div>	Off, On	Deactivates error 3 (flowrate > 103%), if masking = on
<div style="border: 1px solid black; padding: 2px; margin-bottom: 5px;"> Error 4 mask Off </div>	Off, On	Deactivates error 4 (ext. zero return), if masking = on
<div style="border: 1px solid black; padding: 2px; margin-bottom: 5px;"> Qmax pulse 2.5 m³/h </div>	Numerical entry	Expanded flow totalization to the maximum flow range Qmax DN. This parameter is displayed only if the measuring range specified is less than Qmax DN.
<div style="border: 1px solid black; padding: 2px; margin-bottom: 5px;"> Pulse factor 100/m³ </div>	Numerical entry Dynamic limits	The pulse width is configurable only for the limits calculated by the transmitter. The limits are based on the pulse factor. The transmitter cannot leave the max. limits of 2000 ms and 0.1 ms.
<div style="border: 1px solid black; padding: 2px; margin-bottom: 5px;"> Pulse width 0.1 ms </div>	Numerical entry Dynamic limits	The pulse width is configurable only for the limits calculated by the transmitter. The limits are based on the pulse factor. The transmitter cannot leave the max. limits of 2000 ms and 0.1 ms.
<div style="border: 1px solid black; padding: 2px; margin-bottom: 5px;"> Pulse (Act./Pas.) Active </div>	Read only	Displays the 'active' or 'passive' jumper position see also Checks before commissioning on page 40.

... 8 Operation

... Parameter descriptions

Submenu / parameter	Value range	Remark
<div style="border: 1px solid black; padding: 2px; width: fit-content;">Submenu</div> <div style="border: 1px solid black; padding: 2px; width: fit-content; margin-left: 20px;">Progr. Input/output</div>		
<div style="border: 1px solid black; padding: 2px; width: fit-content; margin-left: 40px;">Switch input</div> <div style="border: 1px solid black; padding: 2px; width: fit-content; margin-left: 40px;">No function</div>	No function Totalizer reset Ext. cut-off Ext. Syst. NP.	<p>Selection of the function for switch input terminals 81/82.</p> <p>'Totalizer Reset' resets the internal totalizer and counter overflows by connecting a switching voltage. For 'Ext. Zero Return' all outputs are switched off, if a switching voltage is connected. Example of use: undefined filled meter tube condition after turning off pumps or cyclic cleaning or flushing procedures, the measured values of which must be hidden.</p> <p>Select 'Ext. Syst. NP' to adjust the system zero point. The fluid must be at absolute standstill during the adjustment. The message 'Warning 13' is displayed during the adjustment.</p>
<div style="border: 1px solid black; padding: 2px; width: fit-content; margin-left: 40px;">Switch output</div> <div style="border: 1px solid black; padding: 2px; width: fit-content; margin-left: 40px;">No function</div>	No function F/R signal /_ F/R Signal __ General Alarm /_ General Alarm __ Max/Min Alarm/_ Max/Min Alarm __ Min Alarm /_ Min Alarm __ Max Alarm /_ Max Alarm __ Empty Pipe /_ Empty Pipe __ Ext. Diag. Alarm /_ Ext. Diag. Alarm __	<p>The switching behavior for the contact outputs (terminal 41/42) can be selected as normally open (/_) or normally closed (__).</p> <p>For the 'General Alarm' all detected errors (0 - 6, A, B, C, D, E, F, G) are signaled via the terminals. Select "Ext. Diag. Alarm" to signal only diagnosis errors that have occurred. If you want to report a low flow condition, select 'Min Alarm'. Similarly, a high flow condition is signaled with 'Max Alarm'. If the signal is set for 'Max/Min Alarm', then a signal is sent over the terminals when the flow rate is above or below the range between the 'Max-Alarm' value and the 'Min-Alarm' value, i.e., when the flow rate is larger than the 'Max-Alarm' value or less than the 'Min-Alarm' value.</p>

Submenu / parameter	Value range	Remark
<div style="border: 1px solid black; padding: 2px; width: fit-content;">Submenu Identifier</div>		
<div style="border: 1px solid black; padding: 2px; width: fit-content;">Curr. Variant</div>	Read only Active pulse without HART Active pulse with HART Passive pulse without HART Passive pulse with HART Variant error	Displays the pulse output and communication configuration for the shipped model.
<div style="border: 1px solid black; padding: 2px; width: fit-content;">Sensor TAG '.....'</div>	User-defined text	A TAG number to identify the flowmeter sensor, max. 32-character limit.
<div style="border: 1px solid black; padding: 2px; width: fit-content;">Transmitter TAG '.....'</div>	User-defined text	A TAG number to identify the transmitter, max. 32-character limit.
<div style="border: 1px solid black; padding: 2px; width: fit-content;">Submenu Interface</div>		
<div style="border: 1px solid black; padding: 2px; width: fit-content;">Communication without</div>	Without HART	1. HART communication Set the HART communication to ON or OFF. When HART communication is not required, Current Output ranges 0-20, 0-10, 2-10 mA can be selected. For HART communication, the current output is always 4 - 20 mA. No selection available for standard devices (without HART hardware).
<div style="border: 1px solid black; padding: 2px; width: fit-content;">Device address 0</div>	Numerical entry 0 ... 15	For devices with HART protocol, an address between 0 ... 15 can be selected. If Address 0 is entered, the current output for the flow rate will also change by 4 - 20 mA. If more devices are connected to the bus and the address 1 - 15 is selected, the transmitter will work in multidrop mode. The current output value then remains frozen at 4 mA. In this case, the output values can only be read using HART communication. Warning 11 is displayed. No entry for standard devices (without HART hardware).

... 8 Operation

... Parameter descriptions

Submenu / parameter	Value range	Remark
<div style="border: 1px solid black; padding: 2px; width: fit-content;">HART TAG 'HART TAG'</div>	User-defined text	Unique identifier for unit using HART TAG number. Max. 8-character TAG number (PCKASCII string). Only capital letters are recognized, no special characters can be used. No entry for standard devices (without HART hardware).
<div style="border: 1px solid black; padding: 2px; width: fit-content;">HART descriptor 'HART descriptor'</div>	User-defined text	Description max. 16-character (PCKASCII string). Only capital letters are recognized, no special characters can be used. No entry for standard devices (without HART hardware).
<div style="border: 1px solid black; padding: 2px; width: fit-content;">HART Date 11/3/2003</div>	Day Month year	Enter and output a date in this submenu. No entry for standard devices (without HART hardware).

Submenu / parameter	Value range	Remark
<div style="border: 1px solid black; padding: 5px; margin-bottom: 10px;">Error Mask</div> <div style="border: 1px solid black; padding: 5px; margin-left: 20px; margin-bottom: 10px;"> Bitstring 0 ON EF0F0000 Error A Max Alarm </div> <div style="border: 1px solid black; padding: 5px; margin-left: 20px; margin-bottom: 10px;"> Warning Mask </div> <div style="border: 1px solid black; padding: 5px; margin-left: 20px; margin-bottom: 10px;"> Bitstring 0 OFF 020000100 Warning: 10 Reverse Q </div> <div style="border: 1px solid black; padding: 5px;"> Software Rev. Communication: 1 </div>	<p style="text-align: center;">Read only</p>	<p>This menu shows the screen for the error register (TB Index 95).</p> <p>Line 1 shows the setting of the bit (on/off), which is indicated by its bitstring number. Line 2 shows the complete screen in hex characters. Lines 3 and 4 provide plaintext descriptions of each bit. Select the bits via the keys Data and Step, and select ENTER to switch the bit on/off.</p> <p>See also the 'Error Register' in the interface description D184B093U31.</p> <p>This menu shows the screen for the warning register (TB Index 96).</p> <p>Operation is identical to Error screen. See Warning Register 9.8.3 and interface description D184B093U31, page 47.</p> <p>Displays the communication software version.</p>

... 8 Operation

... Parameter descriptions

Submenu / parameter	Value range	Remark
Submenu Function test		Note Once the self-test function is initiated, the transmitter no longer operates in online mode, i.e., the outputs no longer track the flowrate.
Memory Test		Test the memory. Internal FRAM, ext. FRAM and calc. Flash can be queried in order via ENTER function.
Pulse output 0 Hz	Numerical entry	Test the pulse output. Enter a value directly in Hz.
Current output 4 mA	0 - 20 mA, 4 - 20 mA 0 - 10 mA, 2 - 10 mA	Test the current output. Check the value displayed at the connection terminals using a digital voltmeter or the process instrumentation. Enter a value directly in mA. No selection available if the HART device address is anything other than 0.
Contact input Off	Off A	Test the contact input. If no signal is applied to the switch input, the text 'Off' is displayed in this menu. Once a signal is applied, the text 'On' is displayed (to check via simulator, use the Totalizer Reset button).
Switch output Off	Off A	Test the contact output. When you set the value to 'On', the switch output selected is displayed for the configured contact logic under the item Switch Contacts - Switch Output.
Display		Test the display. Every point in the dot matrix is activated one after another. Once all points are activated, a missing point is easily detected.
Test Mode Off	Off A	Only for checking the transmitter using Simulator 55XC4000.

Submenu / parameter	Value range	Remark
<div style="border: 1px solid black; padding: 5px; margin-bottom: 10px;">Simulation Mode Off</div> <div style="border: 1px solid black; padding: 5px; margin-left: 20px;">Simulation Value 0.0 %</div>	Off A Numerical entry -130 % - +130 %	On/Off function for Simulation mode. Before operation with flow, a flowrate can be simulated. The output values correspond to the simulated flowrate entered. The information ** Q Simulation** is displayed in the lower line of the display. After completing the simulation, change the parameter in the Simulation Mode menu to 'Off'. Select the simulation value for the display and outputs. Current and pulse output follow the flowrate value.
<div style="border: 1px solid black; padding: 5px; margin-bottom: 10px;">Submenu Diagnosis</div> <div style="border: 1px solid black; padding: 5px; margin-left: 20px;">Diagnosis Manual</div>		Menu available only if the required hardware is available. Menu is displayed only with 'Manual' diagnosis interval.
<div style="border: 1px solid black; padding: 5px; margin-left: 40px;">Start? Yes → Enter</div>	Yes, exit via C/CE	Manually start manual diagnostic. The value is displayed after a delay of 30 s.
<div style="border: 1px solid black; padding: 5px; margin-bottom: 10px;">Submenu Diag. Interval</div> <div style="border: 1px solid black; padding: 5px; margin-left: 20px;">Cycle Time Manual</div>	Manual; 10 s; 60 s; 10 min; 60 min; 6 h; 12 h; 24 h; 7 d	Select the time interval between the individual diagnostic measurements. For the values for Coil Resistance, Coil Temperature, Insulation Resistance, and Magnetic Linearity, however, there are minimum measurement intervals for technical reasons related to the measurement: <ul style="list-style-type: none"> • 60 seconds for Coil Resistance and Coil Temperature • 5 minutes for Magnetic Linearity • 10 minutes for measurement of Insulation Resistance These times are not undershot independently of the configured diagnostic cyclic.

... 8 Operation

... Parameter descriptions

Submenu / parameter	Value range	Remark
Submenu Alarm Settings		In this menu you can set minimum and maximum values for each measurement value. Depending on the selected configuration, you can select for no message, a warning, or an error message to be displayed, if the value falls below or exceeds this threshold.
Submenu Alarm Coil Voltage		Set the time-out limits and alarm behavior for values over or under the coil AC voltage.
Min. value 1.0 V	0 ... 150	Lower range limit for alarm
Max. value 150 V	0 ... 150	Upper range limit for alarm
Message Off	Off, warning, error	Defines the alarm behavior
Submenu Alarm Coil Current		Set the time-out limits and alarm behavior for values over or under the coil AC.
Min. value 20.0 mA	0 ... 500	Lower range limit for alarm.
Max. value 500.0 mA	0 ... 500	Upper range limit for alarm.
Message Off	Off, warning, error	Defines the alarm behavior.

Submenu / parameter	Value range	Remark
<div style="border: 1px solid black; padding: 2px; width: fit-content;"> Submenu Alarm Coil Resist </div>		<p>Set the time-out limits and alarm behavior for values over or under the coil resistance.</p> <p>Notice: To correctly display the coil resistance or coil temperature, an adjustment is required or the cable length must be entered. For additional information, see 'Submenu Adjustment' on page 78.</p>
<div style="border: 1px solid black; padding: 2px; width: fit-content;"> Min. value 2 ohms </div>	0 ... 1500	Lower range limit for alarm.
<div style="border: 1px solid black; padding: 2px; width: fit-content;"> Max. value 500 ohms </div>	0 ... 500	Upper range limit for alarm.
<div style="border: 1px solid black; padding: 2px; width: fit-content;"> Message Off </div>	Off, warning, error	<p>Defines the alarm behavior.</p> <p>Notice: If coil resistance is being measured (at least every 60 s), the most recently acquired flow rate is retained during the measurement (2 s approx.).</p>

... 8 Operation

... Parameter descriptions

Submenu / parameter	Value range	Remark
Submenu Alarm Coil Temp		Set the time-out limits and alarm behavior for values over or under the coil temperature. Notice: To correctly display the coil resistance or coil temperature, an adjustment is required or the cable length must be entered. For additional information, see 'Submenu Adjustment' on page 78.
Min. value -50 °C	-100 ... 200	Lower range limit for alarm.
Max. value 200 °C	-100 ... 200	Upper range limit for alarm.
Message Off	Off, warning, error	Defines the alarm behavior. Notice: If coil resistance is being measured (at least every 60 s), the most recently acquired flow rate is retained during the measurement (2 s approx.).
Submenu Alarm Ins Resist		Set the time-out limits and alarm behavior for values over or under the coil temperature.
Min. value 1 megaohm	0 ... 100000	Lower range limit for alarm.
Max. value 50 megaohm	0 ... 100000	Upper range limit for alarm.
Message Off	Off, warning, error	Defines the alarm behavior. Notice: If coil insulation resistance is being measured (at least every 10 minutes), the most recently acquired flow rate is retained during the measurement (2 s approx.).

Submenu / parameter	Value range	Remark
Submenu Alarm E1 Voltage		Set the time-out limits and alarm behavior for values over or under the electrode AC voltage for electrode E1.
Min. value 0.0 μV	0 ... 3000	Lower range limit for alarm.
Max. value 3000.0 μV	0 ... 3000	Upper range limit for alarm.
Message Off	Off, warning, error	Defines the alarm behavior. Notice: To properly display the electrode voltage, the electrode zero point must be adjusted. For additional information, see 'Submenu Adjustment' on page 78.
Submenu Alarm E2 Voltage		Set the time-out limits and alarm behavior for values over or under the electrode AC voltage for electrode E2.
Min. value 0.0 μV	0 ... 3000	Lower range limit for alarm.
Max. value 3000.0 μV	0 ... 3000	Upper range limit for alarm.
Message Off	Off, warning, error	Defines the alarm behavior. Notice: To properly display the electrode voltage, the electrode zero point must be adjusted. For additional information, see 'Submenu Adjustment' on page 78.

... 8 Operation

... Parameter descriptions

Submenu / parameter	Value range	Remark
Submenu Alarm Elec Bal		Set the time-out limits and alarm behavior for values over or under the electrode balance. The electrode balance is calculated as the ratio between the electrode AC voltages E1/E2. This value is displayed in [%]. If the electrode voltage E2 is larger than E1, the value is assigned a minus sign and the ratio E2/E1 is displayed.
Min. value 0.0 %	100 ... 300	Lower range limit for alarm.
Max. value 300.0 %	100 ... 300	Upper range limit for alarm.
Message Off	Off, warning, error	Defines the alarm behavior. Notice: To properly display the electrode voltage, the electrode zero point must be adjusted. For additional information, see 'Submenu Adjustment' on page 78.
Submenu Alarm Mag Lin		Set the time-out limits and alarm behavior for values over or under the magnetic linearity.
Min. value 0.0 %	0 ... 100	Lower range limit for alarm.
Max. value 100.0 %	0 ... 100	Upper range limit for alarm.
Message Off	Off, warning, error	Defines the alarm behavior. Notice: If magnetic linearity is being measured (at least every 5 minutes), the most recently acquired flow rate during the measurement is retained (approx. 2 s).

Submenu / parameter	Value range	Remark
Submenu Alarm SNR		Set the time-out limits and alarm behavior for values over or under the signal-to-noise ratio.
Min. value 0.0 %	0 ... 100	Lower range limit for alarm.
Max. value 100.0 %	0 ... 100	Upper range limit for alarm.
Message Off	Off, warning, error	Defines the alarm behavior.
Submenu Alarm DAC Value		Set the time-out limits and alarm behavior for values over or under the DAC value. The DAC value is a criterion for the amount of coil current.
Min. value 16	0 ... 1024	Lower range limit for alarm.
Max. value 700	0 ... 1024	Upper range limit for alarm.
Message Off	Off, warning, error	Defines the alarm behavior.

... 8 Operation

... Parameter descriptions

Submenu / parameter	Value range	Remark
<div style="border: 1px solid black; padding: 2px; margin-bottom: 5px;"> Submenu Alarm Factory Set </div> <div style="border: 1px solid black; padding: 2px; margin-left: 20px;"> Accept Yes → Enter </div>	Yes, exit via C/CE	Sets the status of all alarms to 'Off' and the alarms to the default values.
<div style="border: 1px solid black; padding: 2px;"> Submenu Wired-on. Failure </div>		Defines alarm behavior in case of an accidental coil ground. Notice: If the coil circuit is being checked (at least every 10 minutes) for an accidental ground, the most recently acquired flow rate is maintained (approx. 2 s).
<div style="border: 1px solid black; padding: 2px; margin-bottom: 5px;"> Submenu CoilShtCircGnd </div> <div style="border: 1px solid black; padding: 2px; margin-left: 20px;"> Message Off </div>	Off, warning, error	Defines alarm behavior in case of a short circuit or a wire break in the electrode circuit. Notice: This function can only be used after the electrode zero has been adjusted. For additional information, see 'Submenu Adjustment' on page 78.
<div style="border: 1px solid black; padding: 2px; margin-bottom: 5px;"> Submenu Electrode State </div> <div style="border: 1px solid black; padding: 2px; margin-left: 20px;"> Message Off </div>		Off, warning, error

Submenu / parameter	Value range	Remark																																						
<div style="border: 1px solid black; padding: 2px; width: fit-content; margin-bottom: 10px;">Submenu Fingerprint</div> <div style="border: 1px solid black; padding: 2px; width: fit-content; margin-left: 100px; margin-bottom: 10px;">Submenu Fprt1</div> <div style="border: 1px solid black; padding: 2px; width: fit-content; margin-left: 100px; margin-bottom: 10px;">Diagnostic Value AC Volt. coil</div> <div style="border: 1px solid black; padding: 2px; width: fit-content; margin-left: 100px; margin-bottom: 10px;">Data set Current</div> <div style="border: 1px solid black; padding: 2px; width: fit-content; margin-left: 100px;">Submenu Fprt4</div>	<p>AC Volt. coil; AC Current coil; ohm. res. coil; Temp. coil; ins. res. coil; Volt. E1; Volt. E2; Electr. balan.;; Magn. linear; SNR noise ratio; Max. DAC value; Oprtg. hrs trn; Oprtg. hrs sens</p> <p>Current; Prod1; Prod2; Startup; Factory; Hist1; Hist2; Hist3; Hist4; Hist5; Hist6; Hist7; Hist8; Hist9</p> <p>As for Fprt1</p>	<p>Preselect the diagnostic measurement values that you want to display and manage in the Fingerprint data.</p> <p>Assign the rate for Fprt1. The display line for the process indicator is assigned in the submenu.</p> <p>Select the value:</p> <table border="0"> <tr> <td>AC Volt. Coil:</td> <td>Coil voltage AC</td> </tr> <tr> <td>AC Current Coil:</td> <td>Coil current AC</td> </tr> <tr> <td>ohm. res. Coil:</td> <td>Ohmic resistance of coil</td> </tr> <tr> <td>Temp. coil:</td> <td>Coil temperature</td> </tr> <tr> <td>ins. res. Coil:</td> <td>Insulation resistance of coil</td> </tr> <tr> <td>Volt. E1:</td> <td>AC voltage at electrode 1</td> </tr> <tr> <td>Volt. E2:</td> <td>AC voltage at electrode 2</td> </tr> <tr> <td>Electr. balan.:</td> <td>Electrode balance</td> </tr> <tr> <td>Magn Linear:</td> <td>Magnetic linearity</td> </tr> <tr> <td>SNR Noise ratio:</td> <td>Signal-to-noise ratio</td> </tr> <tr> <td>Max DAC value:</td> <td>Maximum DAC value</td> </tr> <tr> <td>Oprtg. hrs trn::</td> <td>Operating hours for transmitter</td> </tr> <tr> <td>Oprtg. hrs sens::</td> <td>Operating hours for sensor</td> </tr> </table> <p>These values are updated only if the status was set to Warning or Error in the 'Alarm Settings' submenu.</p> <table border="0"> <tr> <td>Current:</td> <td>Data set for current measured value</td> </tr> <tr> <td>Prod1:</td> <td>Product1 fingerprint</td> </tr> <tr> <td>Prod2:</td> <td>Product2 fingerprint</td> </tr> <tr> <td>Start-up:</td> <td>Commissioning fingerprint</td> </tr> <tr> <td>Default:</td> <td>Default fingerprint</td> </tr> <tr> <td>Hist1-9:</td> <td>Data set 1 ... 9 for the preceding measured values</td> </tr> </table> <p>Assign the rate for Fprt1. The display line for the process indicator is assigned in the submenu.</p>	AC Volt. Coil:	Coil voltage AC	AC Current Coil:	Coil current AC	ohm. res. Coil:	Ohmic resistance of coil	Temp. coil:	Coil temperature	ins. res. Coil:	Insulation resistance of coil	Volt. E1:	AC voltage at electrode 1	Volt. E2:	AC voltage at electrode 2	Electr. balan.:	Electrode balance	Magn Linear:	Magnetic linearity	SNR Noise ratio:	Signal-to-noise ratio	Max DAC value:	Maximum DAC value	Oprtg. hrs trn::	Operating hours for transmitter	Oprtg. hrs sens::	Operating hours for sensor	Current:	Data set for current measured value	Prod1:	Product1 fingerprint	Prod2:	Product2 fingerprint	Start-up:	Commissioning fingerprint	Default:	Default fingerprint	Hist1-9:	Data set 1 ... 9 for the preceding measured values
AC Volt. Coil:	Coil voltage AC																																							
AC Current Coil:	Coil current AC																																							
ohm. res. Coil:	Ohmic resistance of coil																																							
Temp. coil:	Coil temperature																																							
ins. res. Coil:	Insulation resistance of coil																																							
Volt. E1:	AC voltage at electrode 1																																							
Volt. E2:	AC voltage at electrode 2																																							
Electr. balan.:	Electrode balance																																							
Magn Linear:	Magnetic linearity																																							
SNR Noise ratio:	Signal-to-noise ratio																																							
Max DAC value:	Maximum DAC value																																							
Oprtg. hrs trn::	Operating hours for transmitter																																							
Oprtg. hrs sens::	Operating hours for sensor																																							
Current:	Data set for current measured value																																							
Prod1:	Product1 fingerprint																																							
Prod2:	Product2 fingerprint																																							
Start-up:	Commissioning fingerprint																																							
Default:	Default fingerprint																																							
Hist1-9:	Data set 1 ... 9 for the preceding measured values																																							

... 8 Operation

... Parameter descriptions

Submenu / parameter	Value range	Remark
<pre> graph TD Transfer[Submenu Transfer] --> Product1[As Product1] Transfer --> Product2[As Product2] Transfer --> Startup[As Startup] Transfer --> Adjustment[Submenu Adjustment] Product1 --> Accept1[Accept Yes -> Enter] Product2 --> Accept2[Accept Yes -> Enter] Startup --> Accept3[Accept Yes -> Enter] Adjustment --> CoilTemp[Submenu Coil Temp] CoilTemp --> Temp[Temp. in °C 0.0] </pre>	<p>Yes, exit via C/CE</p> <p>Yes, exit via C/CE</p> <p>Yes, exit via C/CE</p> <p>-100 ... 100</p>	<p>Import the current data set in a Fingerprint.</p> <p>Copies the current data set in the Fingerprint 'as Product1'.</p> <p>Copies the current data set in the Fingerprint 'as Product2'.</p> <p>Copies the current data set in the Fingerprint 'as Start-up' (commissioning fingerprint).</p> <p>Enter the current coil temperature to readjust the coil resistance at 20 °C. Perform adjustment only on a 'cold' device. See Additional information regarding use of enhanced diagnostic functions on page 82 in this regard.</p>

Submenu / parameter	Value range	Remark
Submenu CabLength Length [m] 0.0	0 ... 200	Enter the length of the signal cable. Notice: Information must be entered to calculate the coil resistance / coil temperature.
Submenu Temp. Offset Temp. in °C 0.0	-100 ... 100	Offset correction for temperature display.
Import RT20 Accept New 500 ohms Old 450 ohms Yes → Enter	Yes, exit C/CE	Import the reference resistance for the coil. See Additional information regarding use of enhanced diagnostic functions on page 82 in this regard. Notice: This menu is displayed only when the coil resistance or coil temperature are enabled as an error or warning message.
Electr. Zero Point Electr. Zero Point New 150 180 μV Old 200 190 μV Yes → Enter	Yes, exit C/CE	This adjustment is required in order to use the diagnostic measurement values for the electrode voltage E1/E2 and the electrode balance as well as the wiring errors for the electrode state. Display the current (new) and stored (old) zero values for electrode E1/E2. Select 'Enter' to import the current zero points Notice: The liquid in the sensor must be at absolute standstill.
Electr. Analysis N1: 12 μV 286° N2: 10 μV 283° A1: 650 μV 133° A2: 670 μV 135°	Yes, exit C/CE	Displays stored electrode zero and current electrode AC voltage acc. to amount and phase. Where N1: Current measured electrode AC voltage E1 N2: Current measured electrode AC voltage E2 A1: Stored zero point E1 A2: Stored zero point E2

... 8 Operation

... Parameter descriptions

Submenu / parameter	Value range	Remark
<div style="border: 1px solid black; padding: 2px; margin-bottom: 5px;"> Submenu Status </div> <div style="border: 1px solid black; padding: 2px; margin-bottom: 5px; margin-left: 20px;"> Error register Amount: 1 </div> <div style="border: 1px solid black; padding: 2px; margin-left: 40px; margin-bottom: 5px;"> C (Current) Ext. Database </div> <div style="border: 1px solid black; padding: 2px; margin-left: 40px; margin-bottom: 5px;"> Reset: Enter Help text: Step </div> <div style="border: 1px solid black; padding: 2px; margin-left: 40px; margin-bottom: 5px;"> 0 Empty pipe </div> <div style="border: 1px solid black; padding: 2px; margin-left: 20px; margin-bottom: 5px;"> Warning register Amount: 2 </div> <div style="border: 1px solid black; padding: 2px; margin-left: 40px; margin-bottom: 5px;"> 3 (Pending) * Test Mode * </div> <div style="border: 1px solid black; padding: 2px; margin-left: 40px; margin-bottom: 5px;"> Reset: Enter Help text: Step </div> <div style="border: 1px solid black; padding: 2px; margin-left: 40px; margin-bottom: 5px;"> 2 Counter reset </div> <div style="border: 1px solid black; padding: 2px; margin-left: 20px; margin-bottom: 5px;"> Power outage 0 </div> <div style="border: 1px solid black; padding: 2px; margin-left: 20px; margin-bottom: 5px;"> HMx ----- </div> <div style="border: 1px solid black; padding: 2px; margin-left: 20px; margin-bottom: 5px;"> HMi ----- </div> <div style="border: 1px solid black; padding: 2px; margin-left: 20px; margin-bottom: 5px;"> EMx ----- </div> <div style="border: 1px solid black; padding: 2px; margin-left: 20px;"> EMi ----- </div>		<p>After calling up the error register, the error register text is displayed with the number of pending errors. Press ENTER again to display the pending errors with error number and text. If you press ENTER again, you will be asked whether you want to reset the error or view the help text. Select STEP to display all of the pending errors with error numbers and text. Press ENTER to reset the pending errors.</p> <p>After calling up the warning register, the warning register text is displayed with the number of pending warnings. Press ENTER again to display the pending warnings with warning number and text. If you press ENTER again, you will be asked whether you want to reset the warnings or view the help text. Select STEP to display all of the pending warnings with warning numbers and text. Press ENTER to reset the pending warnings.</p> <p>Display the power outages during operation.</p> <p>Status register for enhanced diagnostics. For more information see Additional information regarding use of enhanced diagnostic functions on page 82.</p>

Submenu / parameter	Value range	Remark
WMx -----		
Wmi -----		
ConWarn ----- -----		
ConErr-----		
Submenu Syst. Adjust		
Start System Zero 0.0 %	Manual Autom, adjustment	Check zero, if necessary (when adapting an older flowmeter sensor). Manual entry, e.g., when replacing the transmitter.
System zero point 0.0 %	Numerical entry	Automatic adjustment: Valve must be closed, liquid in sensor must be at absolute standstill. Press ENTER to perform the automatic adjustment. The limit for the zero point is ± 10%. If the value is outside this limit, no calibration is performed.
FSM4000 12/2019 3KXF00001S0001 D.14	Read only	Display software version. 01.2010 specifies the date of the release. C.11 = Version level, for standard and HART protocol.

... 8 Operation

Additional information regarding use of enhanced diagnostic functions

Additional diagnostic functions are available in combination with sensors SE41F, SE21 and SE21F with nominal diameters > DN 8 and larger. The following section describes how to determine individual values.

Determining the coil alternating current or coil alternating voltage

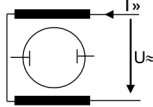

Figure 44

For detecting changes in the coil circuit. The current and voltage are measured directly. These do not influence the flow measurements. To perform the measurement, you need to power-up one of the relevant errors or a warning in the submenu 'Diagnostics/Alarm Settings' (see page 70).

Determining the coil DC resistance

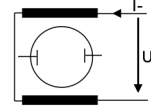

Figure 45

$$R_{\text{Spule}} = \frac{U_{\text{Spule}}}{I_{\text{Spule}}}$$

For monitoring changes in the coil circuit, e.g., fine short of the coil.

When measuring the coil DC resistance, a DC field excitation of approx. 1 sec is used as a test signal. Because the incoming test signal prevents flow measurement, the most recent value is retained.

To perform this test, you need to power-up one of the relevant errors or warnings in the submenu 'Diagnostics / Alarm Settings' (see page 70).

Note

To make sure that information is displayed properly, the signal cable length must be entered in the submenu 'Diagnostic / Adjustment / CabLength' (see page 79).

Determining the coil temperature

The coil temperature is a factor of the ambient and fluid temperatures. The measurement can be for example used to monitor overtemperature through the medium.

The coil temperature is measured indirectly via the coil DC resistor (ABB Patent GB 2 348 011).

To perform the measurement, you need to power-up one of the relevant errors or a warning in the submenu 'Diagnostics / Alarm Settings' (see page 70).

$$T_{\text{Coil}} = \frac{R_{\text{Coil}} - R_{\text{Ref}}}{\alpha_{\text{Ref}} \cdot R_{\text{Ref}}} + 20 \text{ }^{\circ}\text{C}$$

T_{Coil} Coil temperature

R_{Coil} Coil resistance

R_{Ref} Reference coil resistance at 20 °C

α_{Ref} Temperature coefficient of copper at 20 °C (0.39 %/K)

Note

The coil resistance of the flowmeter sensor must be adjusted for a reference temperature. This applies to newly shipped systems consisting of SE41F / SE21 and S4. When connecting an S4 transmitter to previously shipped SE41F / SE21 sensors, you need to additionally perform the adjustment. For more information in this regard, see **Readjusting the coil temperature** on page 91.

Determining the insulation resistance for the coil

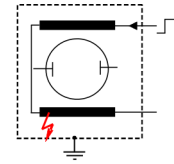

Figure 46

Detecting problems with the coil insulation. Can be caused, e.g., by dampness in the flowmeter sensor or in the connection box. When determining the insulation resistance of the coil to ground, a DC field test signal of approx. 1 sec is sent to the coil, separating the ground connection in the transmitter. In spite of the separation provided by the coil, the current flowing to ground is used to calculate the insulation resistance. During this measurement, the flowrate cannot be measured and the most recent value is retained.

To perform this test, you need to power-up one of the relevant errors or warnings in the submenu 'Diagnostics / Alarm Settings' (see page 70).

... 8 Operation

... Additional information regarding use of enhanced diagnostic functions

Determining the E1 and E2 electrode AC voltage

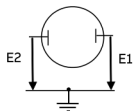

Figure 47

Primary signal for determining the electrode balance.

The electrode AC voltages are measured at the electrodes E1 and E2 to ground. The voltage measured is proportional to the flowrate.

The electrode AC voltage can be measured without affecting the flow measurement in any way.

To perform this measurement, you need to power-up one of the relevant errors or a warning in the submenu 'Diagnostics / Alarm Settings' (see page 70).

Note

The electrode zero point must be adjusted in the submenu 'Diagnostics / Adjustments / Electr. Zero Point' (see page 79).

Determining the electrode balance

$$E1 \geq E2 \rightarrow EB = \frac{E1}{E2} \%$$

$$E1 < E2 \rightarrow EB = (-) \frac{E2}{E1} \%$$

Detect distorted flow profile, e.g., due to improper installation.

Detect interference in electrode circuit, e.g., failure of electrode due to insulating coating or a collapsed liner (vacuum shock).

The electrode balance (EB) is calculated as the ratio between the electrode AC voltages E1/E2 or E2/E1. This value is displayed in [%]. To prevent false alarms, alarms are not triggered for electrode AC voltages below 20 μ V, regardless of the alarm setting which has been selected.

The EB is measured without affecting the flow measurement in any way. To perform this measurement, you need to power-up one of the relevant errors or a warning in the submenu 'Diagnostics / Alarm Settings' (see page 70).

Note

The electrode zero point must be adjusted in the submenu 'Diagnostics / Adjustments / Electr. Zero Point' (see page 79).

Determining the signal-to-noise ratio

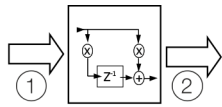

- ① Signal from the sensor ② Filtered signal

Illustration48:

Detect changes in the measuring medium, e.g., gas bubbles, increased/reduced solid content.

To determine the signal-to-noise ratio (SNR), the electrode AC voltage - raw signal for the sensor is set in relation to the digitally filtered signal.

$$SNR = \frac{\text{GefiltertesSignal}}{\text{Signal vom Messwertaufnehmer}}$$

The SNR is measured without impairing the flow measurement in any way. To perform this calculation, you need to power-up one of the relevant errors or a warning in the submenu Diagnostics / Alarm Settings (see page 70).

Determining the magnetic linearity

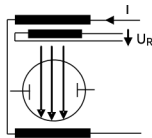

Figure 49

$$ML = \frac{I_1 * U_{R2}}{I_2 * U_{R1}}$$

Detect magnetic field interference. This can affect the accuracy of the measurement.

When measuring magnetic linearity (ML), the coil current I_1 is measured at current reference voltage U_{R1} and coil current I_2 at approximately half the reference voltage U_{R2} .

The operating time at half the reference voltage is approx. 1 sec.

During this period, the most recently acquired value is retained.

To perform this test, you need to power-up one of the relevant errors or warnings in the submenu 'Diagnostics / Alarm Settings' (see page 70).

Determining the maximum DAC value

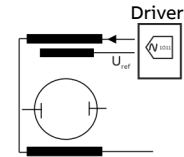

Figure 50

For detecting changes in the coil circuit.

To compensate the set reference voltage U_{ref} , the level of the digital/analog converter (DAC) value is manipulated in the transmitter driver circuit to vary the excitation signal of the coil. The amplitude of this value then serves as an indicator of the level of the excitation signal.

The DAC value is measured without affecting the flow measurement in any way.

To perform this measurement, you need to power-up one of the relevant errors or a warning in the submenu 'Diagnostics / Alarm Settings' (see page 70).

... 8 Operation

... Additional information regarding use of enhanced diagnostic functions

Recommended settings for diagnosis limit values

The values indicated are only intended as a rough guide and may need to be adapted in line with on-site conditions.

Parameter	Minimum value		Maximum value	
Electrode voltage 1	These values depend on the flowrate, so no recommendations can be made here.			
Electrode voltage 2				
Electrode balance ¹⁾	-150 %		150 %	
Coil current	Factory or commissioning fingerprint x 0.95		Factory or commissioning fingerprint x 1.05	
Coil voltage	This value depends on the measuring medium temperature T_{medium}			
	T_{medium}		T_{medium}	
	-40 °C (-40 °F)	Factory fingerprint x 0.81	-40 °C (-40 °F)	Factory fingerprint x 0.89
	-20 °C (-4 °F)	Factory fingerprint x 0.86	-20 °C (-4 °F)	Factory fingerprint x 0.95
	0 °C (32 °F)	Factory fingerprint x 0.9	0 °C (32 °F)	Factory fingerprint x 1
	20 °C (68 °F)	Factory fingerprint x 0.95	20 °C (68 °F)	Factory fingerprint x 1.05
	60 °C (140 °F)	Factory fingerprint x 1.05	60 °C (140 °F)	Factory fingerprint x 1.16
	90 °C (194 °F)	Factory fingerprint x 1.14	90 °C (194 °F)	Factory fingerprint x 1.26
	130 °C (266 °F)	Factory fingerprint x 1.24	130 °C (266 °F)	Factory fingerprint x 1.37
	180 °C (356 °F)	Factory fingerprint x 1.33	180 °C (356 °F)	Factory fingerprint x 1.47
Coil resistance	This value depends on the measuring medium temperature T_{medium}			
	T_{medium}		T_{medium}	
	-40 °C (-40 °F)	Factory fingerprint * 0.71	-40 °C (-40 °F)	Factory fingerprint * 0.79
	-20 °C (-4 °F)	Factory fingerprint * 0.81	-20 °C (-4 °F)	Factory fingerprint * 0.89
	0 °C (32 °F)	Factory fingerprint * 0.9	0 °C (32 °F)	Factory fingerprint * 1
	20 °C (68 °F)	Factory fingerprint * 0.95	20 °C (68 °F)	Factory fingerprint * 1.05
	60 °C (140 °F)	Factory fingerprint * 1.19	60 °C (140 °F)	Factory fingerprint * 1.31
	90 °C (194 °F)	Factory fingerprint * 1.28	90 °C (194 °F)	Factory fingerprint * 1.42
	130 °C (266 °F)	Factory fingerprint * 1.43	130 °C (266 °F)	Factory fingerprint * 1.58
	180 °C (356 °F)	Factory fingerprint * 1.62	180 °C (356 °F)	Factory fingerprint * 1.79
Coil temperature	This value depends on the ambient / measuring medium temperature, so no recommendations can be made here.			

1) This function is only guaranteed if an electrode zero point adjustment has been carried out (see page 79).

Parameter	Minimum value	Maximum value	
Accidental coil ground	10 M Ω	99.9 M Ω	
DAC max		Design level of the flowmeter sensor	
		Nominal diameter	
		A	
		B	
		DN 1 to2 (1/25 to1/12")	
		500	
		-	
		DN 3 to10 (1/10 to3/8")	
		300	
		300	
		DN 15 (1/2")	
		400	
		300	
		DN 20 to25 (3/4 to1")	
		400	
		400	
		DN 32 (1 1/4")	
		400	
		500	
		DN 40 to50 (1 1/2 to2")	
		500	
		500	
		DN 65 (2 1/2")	
		400	
		300	
		DN 80 (3")	
		500	
		300	
		DN 100 to125 (4 to5")	
		500	
		600	
		DN 150 (6")	
		400	
		600	
		DN 200 to300 (8 to12")	
		400	
		700	
		DN 350 to400 (14 to16")	
		500	
		700	
		DN 450 to1000 (18 to40")	
		700	
		700	
Magn. linearity	This value depends on the measuring medium temperature T_{medium}		
	T_{medium}	T_{medium}	
	-40 °C (-40 °F)	Factory fingerprint x 0.86	-40 °C (-40 °F)
			Factory fingerprint x 0.95
	-20 °C (-4 °F)	Factory fingerprint x 0.90	-20 °C (-4 °F)
			Factory fingerprint x 1
	0 °C (32 °F)	Factory fingerprint x 0.93	0 °C (32 °F)
			Factory fingerprint x 1.03
	20 °C (68 °F)	Factory fingerprint x 0.95	20 °C (68 °F)
			Factory fingerprint x 1.05
	60 °C (140 °F)	Factory fingerprint x 1	60 °C (140 °F)
			Factory fingerprint x 1.10
	90 °C (194 °F)	Factory fingerprint x 1.05	90 °C (194 °F)
			Factory fingerprint x 1.16
	130 °C (266 °F)	Factory fingerprint x 1.09	130 °C (266 °F)
			Factory fingerprint x 1.21
	180 °C (356 °F)	Factory fingerprint x 1.14	180 °C (356 °F)
			Factory fingerprint x 1.26
SNR (signal-to-noise ratio)	60 % of the commissioning fingerprint or a higher value, depending on the application.		100 %

... 8 Operation

... Additional information regarding use of enhanced diagnostic functions

Displaying the diagnostic values

Measured values

A maximum of four diagnostic values can be displayed (Fprt1, Fprt2, Fprt3, Fprt4). These values are selected in the submenu Diagnosis / Fingerprint / Fprt1 - 4. In addition to the type of measured value, the desired data set should also be set. This combination of settings can be used to display all stored values.

To enable users to display the different numerical values, an ID code is displayed with each value.

As a result, each line appears as follows:

e.g., CV_RCL 80.5 ohm to display the current coil resistance.

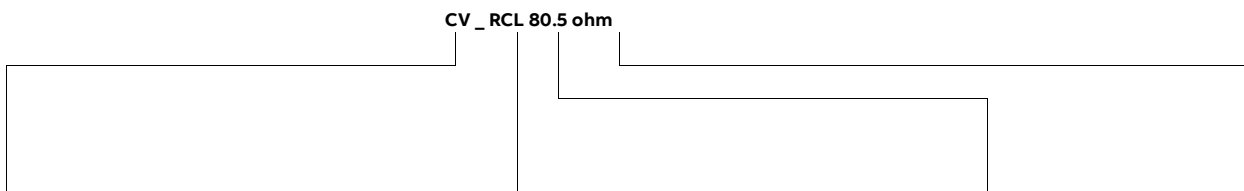

Data set	Type	Numerical value	Unit
CV_: Current value	UAC: Coil voltage (AC)	X.X	V
H1_: History 1	IAC: Coil current (AC)	X	mA
H2_: History 2	RCL: Coil resistance	Value > 100 X Value < 100 X.X	Ohm
H3_: History 3	TCL: Coil temperature	X	°C
H4_: History 4	RIS: Insulation resistance	Value > 100 X Value < 100 X.X	MOhm
H5_: History 5	UE1: Electrode voltage E1	X	µV
H6_: History 6	UE2: Electrode voltage E2	X	µV
H7_: History 7	BAL: Electrode balance	E1 ≥ E2 → +X E1 < E2 → -X	%
H8_: History 8	LIN: Magnetic linearity	X	%
H9_: History 9	SNR: Signal-to-noise ratio	X	%
FV_: Default fingerprint	DAC: Maximum DAC value	X	Dig = Digits
DF_: Commissioning fingerprint			
P1_: Product 1 fingerprint			
P2_: Product 2 fingerprint			

When displaying the operating hours / log time, the ID code combines data set and type without underscore.

Data set	Type	Numerical value	Unit
CVC: Current transmitter operating hours counter		H:Min:Sec	-
P1C: Product1 fingerprint transmitter log time		H:Min:Sec	-
P2C: Product2 fingerprint transmitter log time		H:Min:Sec	-
DFC: Commissioning fingerprint transmitter log time		H:Min:Sec	-
FVC: Default fingerprint transmitter log time		H:Min:Sec	-
H1C – H9C: History 1 – 9 transmitter log time		H:Min:Sec	-
CVP: Current sensor operating hours counter		H:Min:Sec	-
P1P: Product1 fingerprint sensor log time		H:Min:Sec	-
P2P: Product2 fingerprint sensor log time		H:Min:Sec	-
DFP: Commissioning fingerprint sensor log time		H:Min:Sec	-
FVP: Default fingerprint sensor log time		H:Min:Sec	-
H1P – H9P: History 1 – 9 sensor log time		H:Min:Sec	-

... 8 Operation

... Additional information regarding use of enhanced diagnostic functions

Diagnostic warning and error messages

All values acquired during diagnostics or a wiring error can trigger warnings or error messages.

Warnings are displayed in the 4th display line only. In case of an error, in addition to the signal in the 4th display line, the switch output ('General alarm' setting or 'ext. Diag. Alarm' is set to the alarm condition.

To activate this option, select in the submenu 'Diagnosis / Alarm Settings' whether the error or warning is triggered in the event of up-scale or down-scale of the specified range. To check for wiring errors, you can activate this function in the 'Diagnostics / Wiring Error' submenu.

For additional information, refer to the relevant error registers. These can be selected or called up in the 'Display' or 'Status' submenu

The error registers for diagnostic values are structured as follows:

ID code	Set	Off	Designation
S	-	-	Signal quality
L	-	-	Magnetic linearity
B	-	-	Electrode balance
m	-	-	Electrode voltage E1
E	-	-	Electrode voltage E2
D	-	-	DAC value
I	-	-	Insulation resistance
T	-	-	Coil temperature
L	-	-	Coil resistance
R	-	-	Coil voltage
C	-	-	Coil current

↓

ID code	Register name	Content of register
HMx	Hist Max Errors	Error / Warning: Limit value up-scale (max.) while transmitter is powered-up.
HMi	Hist Min Errors	Error / Warning: Limit value down-scale (min.) while transmitter is powered-up.
EMx	Curr Max Errors	Error: Number of current limit value up-scales (max.).
EMi	Curr Min Errors	Error: Number of current limit value down-scales (min.).
WMx	Curr Max Warn	Warning: Number of current limit value up-scales (max.).
WMi	Curr Min Warn	Warning: Number of current limit value down-scales (min.).

The display EMx _R___B_ indicates for example a max. alarm in the current values for the coil resistance and electrode balance.

The error registers for wiring errors are structured as follows:

ID code	Set	Off	Designation
M	-	-	Coil short-circuit to ground
E	-	-	Wiring error for electrodes

↓

ID code	Register name	Content of register
ConWarn	Wiring Warning	Current warnings for wiring
ConErr	Wiring Failure	Current errors for wiring

Readjusting the coil temperature

If a readjustment is required, make sure that the sensor and coil are relatively close to ambient temperature. You might need to allow the sensor to cool off overnight.

Work steps:

- Power-up the transmitter.
- In the submenu 'Diagnostics / Adjustment / CabLength', enter or check the correct signal cable length.
- Enter the ambient temperature in the submenu 'Diagnostics / Adjustment / Coil Temp'.
- Import the new reference resistance in the submenu 'Diagnostics / Adjustment / Import RT20'.

... 8 Operation

Software history

For transmitters without communication or HART protocol

Software D200S021U01

Software version	Type of changes	Documentation / Supplements
B.10	Original software	-
B.11	Improve min. contrast limit. After changing from 50 → 60 Hz the system data now displays the correct frequency.	-
B.12	Shortened Finnish texts. Aut. simulator detection for counter management improved.	-
B.14	FRAM management optimized.	-
B.20	Added Turkish as new language. Added error E (DC too high) Updated flowmeter sensor 10D1462/72.	Added documentation for the additional points.
B.22	Always display the flowrate with 4 decimal places.	-
B.30	Menu item for noise reduction Menu item Meter factor Support for sensors SE21, DN 1 to DN 2	Added documentation for the additional points.
B.31	Hardware compatibility for C-level hardware	-
B.32	Improved totalizer management	-
B.33/B.34	FRAM management optimized	-
C.10	Extended diagnostic functions. Extended noise reduction by 2 more levels. Software supports external zero point adjustment via contact input.	Added documentation for the additional points.
C.11	Improved support for older flowmeter sensor	-
C.20	Improved display operation	-
D.13	Firmware update due to a new microprocessor	-
D.14	Troubleshooting, display freeze	-

S4 operation with older sensor

When operating a transmitter with an older model, the FRAM must be used with the values $C_s = 100\%$ and $C_z = 0\%$. If the transmitter is equipped as such and the devices are mounted according to the electrical connection (see page **Terminal assignment** on page 35 and on), the menu 'Primary Setup' is displayed after power-up of the power supply. Press any key to enter the following information. If you need to correct your entry, you can do so afterward in the system data submenu 'Sensor': in 'Primary Setup'. See page **Primary Setup** on page 55.

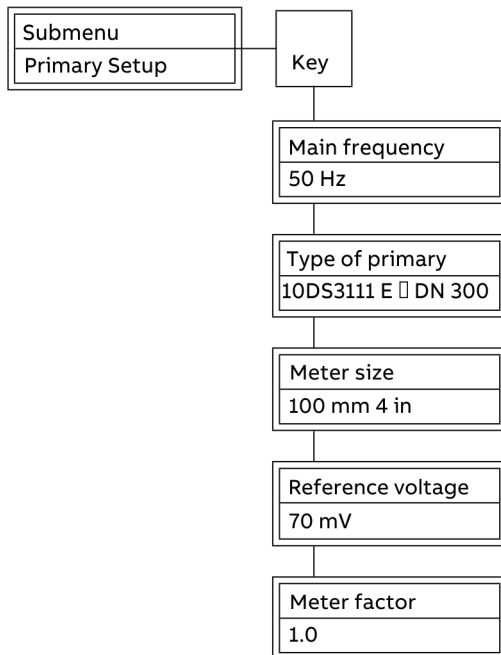

Figure 51: 'Primary Setup' submenu

Entries can be made one after another. In the submenu 'Primary Setup', select the line frequency at which the sensor was calibrated. See name plate. Select the flowmeter sensor type from the list in the table. Check that the letter after the model number and the nominal diameter range are correct. Otherwise, the transmitter will not access the correct reference data.

Enter the relevant meter size. The values are listed for DIN and ANSI sizes. Enter the reference voltage (see the name plate on the flowmeter sensor) in numerical format. (For sensor model 10D1422 or 10DI1425 > DN500, the reference voltage is not required.)

Enter the meter factor (for model 10D1462/72 only). See name plate.

Select the measuring range and other process parameters (damping, low cut-off, current/pulse output, display format, etc.). A system zero adjustment must be performed with a full pipeline at standstill (0 m/s).

Note

If no values are listed for the reference voltage on the name plate, you can request this information from ABB Service. Please provide order number with your request.

e-mail: parts-repair-goettingen@de.abb.com

Phone: +49 180 5222-580

Note

If the flow indicator shows the incorrect flow direction after successful commissioning of the measuring system, e.g., reverse flow instead of forward flow, you should correct this in the Operating Mode submenu of the transmitter.

First switch off the programming protection ('Prog. Level' → 'Specialist'). Then select the parameter 'Directional display' in the submenu 'Operating Mode'. Change 'normal' to 'inverse'. Finally, reactivate programming protection by selecting 'Prog. Level' → 'Locked'.

... 8 Operation

... S4 operation with older sensor

⚠ WARNING

Danger due to electric current!

When the housing is open, EMC protection is impaired and there is no longer any protection against accidental contact.

- Power to all connection leads must be switched off.

Adapting the transmitter to the sensor 10D1422 (DN 3 to 1000), 10D11425 (\geq DN 500):

1. Switch off the power supply. After waiting 40 minutes, remove the housing cover from the field housing unit.
2. Remove the shock protection cover ① by loosening the 3 ② screws.

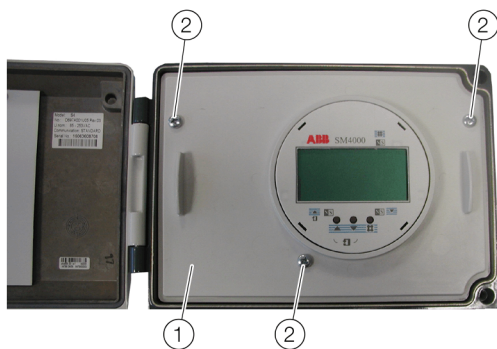

- ① Shock protection cover ② Fixing screw cover

Figure 52: Screwing on the shock protection cover

3. Then close switch S903 ①.

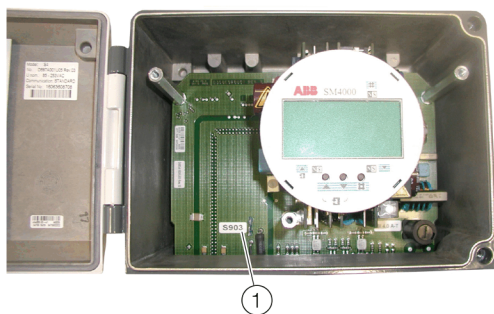

- ① Switch S903

Figure 53: Close switch S903

Type of flowmeter sensor, Nominal diameter DN version level		Connection board with voltage splitter (switch S903 must be closed)	FRAM Version	Coil current supply via:	Reference voltage
SE2_ SE4	1 to 1000	No	With sensor calib. value Cs = see name plate Cz = see name plate	Transmitter S4	automatic
DS2_ DS4_ 10DS3111(A-D) 10DS3111(E)	1 to 1000 ≤ 300 ≤ 400 ≤ 300	No	Cs = calculated; Cz = 0%	Transmitter S4	from name plate
10DI1425	≤ 400	No	Cs = calculated; Cz = 0%	Transmitter S4	90 mV
DS4_ 10DS3111(E)	≥ 350 to 1000 ≥ 350 to 400	No	Cs = calculated; Cz = 0%	Transmitter S4	from name plate
10DS3111(A-C) 10DS3111(D) 10DS3111(E)	≥ 500 ≥ 500 ≥ 500	No	Cs = calculated; Cz = 0%	External power supply	from name plate
10D1422, 10DI1425	3 to 1000 ≥ 500	yes yes	Cs = calculated; Cz = 0%	External power supply	–
10DS3111A 10D1462 10D1472	350 to 600 150 to 900 15 to 100	no, use 1000 Ω adapter board	calculated	External power supply	from name plate

9 Diagnosis / error messages

Overview of error states and alarms

State / Error	Flow rate indicator display	Notification with simulation at current output	Current output	Pulse output	Switch output					Message with HART
					Collective alarm	Min Alarm	Max Alarm	Max/Min Alarm	Empty conduit	
0 = 'Empty conduit'	0 %	-	Prog.Al. DLR	0 %	Alarm				Alarm	More Stat avai.
1 = 'AD converter/DSP'	0 %	-	Prog.Al.	0 %	Alarm					Trans Mal F.
2 = 'Driver'	0 %	-	Prog.Al.	0 %	Alarm					Trans Mal F.
3 = 'Flow rate > 103 %'	103 %	Yes	High.Al	103 %	Alarm					PV out Limits
4 = 'Ext. Zero Return'	0 %	-	0 %	0 %	Alarm					More Stat avai.
5 = 'Database'	0 %	Yes	Prog.Al.	0 %	Alarm					Trans Mal F.
6 = 'Totalizer'	-	Yes	-	-	Alarm					More Stat avai.
A = 'Max Alarm'	-	Yes	-	-	Alarm		Alarm	Alarm		More Stat avai.
B = 'Min Alarm'	-	Yes	-	-	Alarm	Alarm		Alarm		More Stat avai.
C = 'ext. database'	0 %	Yes	Prog.Al.	0 %	Alarm					Trans Mal F.
D = 'Old sensor'	0 %	Yes	Prog.Al.	0 %	Alarm					Trans Mal F.
E = 'DC to high'	0 %	Yes	Prog.Al.	0 %	Alarm					Trans Mal F.
F = 'FRAM in sensor'	0 %	Yes	Prog.Al.	0 %	Alarm					Trans Mal F.
G = 'Diagnosis error'	-	-	-	-	Alarm				Alarm	Trans Mal F.

Error messages during operation and with data entry

The error messages listed below include explanations of the error codes shown in the display. When entering information, the error codes 0 to 6, A, B, C, D, E, G do not appear.

Error code and clear text message	Priority	Description	Possible cause	Corrective action
Error: 0 Empty pipe	5	The meter tube is not full.	The piping is empty and the electrodes are not coming into contact with the measuring medium.	Refill the meter tube. Detector empty tube is on, but the adjustment has not been run. Adjust DLR.
Error: 1 "AD converter / DSP	4	The AD converter is overloaded and is not responding.	Input metering signal is too large. The AD converter/DSP is defective.	Check ground (flowmeter sensor). Check the signal cable and the measuring range setting; the measuring range selected may be too small. Change DSP board.
Error: 2 Driver	7	Positive or negative reference too small.	Check the cables, no reference voltage is present. The flow restrictor in the driver has responded because the driver current is insufficient. Defective driver fuse.	Check connection board and transmitter.
Error: 3 Flow rate > 103 %	6	The max. set measuring range was up-scaled by more than 3 %.	The flowrate is set too high or the measuring range is set too small.	Increase the measuring range, reduce the flowrate.
Error: 4 Ext. Zero Return	8	The flow rate is set to zero; the totalizer is stopped.	The external contact is closed.	The external contact is open again.
Error: 5 Database	2	Loss of the internal database.	Memory module is defective.	Turn unit off and power-up again, call up and run functional test for the transmitter.
Error: 6 Counter	9	Error in totalizer > F. Error totalizer < R Error totalizer	The forward function of the totalizer failed. The reverse function of the totalizer failed. The totalizer function of forward, reverse flow or difference totalizer failed.	Reset forward/reverse flow totalizer or preset new values in totalizer. Totalizer forward, reverse defective. Check transmitter and cables.

... 9 Diagnosis / error messages

... Error messages during operation and with data entry

Error code and clear text message	Priority	Description	Possible cause	Corrective action
Error: A Max. alarm	10, 11	Max alarm limit value.	The configured Max alarm for the flow rate was up-scaled.	Reduce flowrate.
Error: B Min. alarm		Min alarm limit value	The configured Min alarm for the flow rate was down-scaled.	Increase the flow rate.
Error: C Ext. Database	3	External database FRAM is defective or not available.	Missing FRAM or defective FRAM ¹⁾ .	Install and screw in place the FRAM for the relevant flowmeter sensor to the connection board in the field housing unit. Refer to Commissioning on page 40. If the FRAM cannot be read, it must be replaced.
Error: D Old sensor	12	Sensor type from the older model sensor series was selected.	Configuration in the parameter 'Primary Setup' is incomplete.	Please complete parameter configuration in 'Primary Setup'. See also chapter 11 of the operating instruction.
Error: E DC too high	13	Increased analog reset, measurement signal with large DC marked	Air bubbles, deposits on electrodes, too high interference signal. Empty measuring tube.	Activate 'Noise reduction' in the operating mode submenu. Use a de-aerator, clean electrodes, activate empty conduit detector. Contact ABB Service.
Error: F FRAM in sensor	1	Missing data from external FRAM.	FRAM for the flowmeter sensor is still installed in the terminal box.	Install and screw in place the FRAM for the relevant flowmeter sensor to the connection board in the field housing unit. Refer to Commissioning on page 40.
Error: G Diagnosis error	14	Diagnosis or wiring error	Min-Max over/undershoot for diagnostic values.	Retrieve details of error message under the Status submenu in the Wiring error register. Where applicable, Adjust limit value.
			Wiring error for electrode circuit. Coil short-circuit to ground	Retrieve details of error message under the Status submenu in the Wiring error register.

1) Replacing a defective FRAM. If the FRAM is defective and commissioning cannot be performed, a new FRAM can be requested from the Göttingen plant. To properly process requests, you must include the ABB order number and device number of the sensor. After installing the FRAM and switching on the power supply, you can commission the system. Review all sensor data and setup data for the system, and enter this information again, if necessary.

Warning messages during operation

Warning code and ID letter	Priority	Description	Possible cause	Corrective action
Warning: 1 Q Simulation	2	Before operation with flow, a flowrate can be simulated. The output values correspond to the simulated flowrate entered.	Simulation mode on.	After completing the simulation program, switch off the parameter 'Simulation Mode'.
Warning: 2 Totalizer reset	1	All totalizers (forward/reverse, diff. and overflow counters are reset.)	External totalizer reset was performed.	Open the switch at the contact input (terminal 81, 82).
Warning: 3 Test Mode	3	Only for checking the transmitter using Simulator 55XC4000.	Test Mode on.	After running the simulation on the simulator, switch off the parameter 'Test Mode'.
Warning: 4 Function test	4	If during HART communication, the functional test for the switch output or switch input was started, the Warning '4' is displayed.	Function test on.	Leave the routine once the functional test has completed.
Warning: 7 ¹⁾ Ext.Data.loaded	9	Transmitter has detected additional flowmeter sensor data and loaded it to the internal FRAM. System data and sensor data are loaded.	Defective FRAM, repair unit, replacement unit.	Write down all totalizer values, totalizers should be reset.
Warning: 8a ¹⁾ Update int.Dat.	10	Transmitter has detected an error in the internal FRAM and has repaired the data with content of the external FRAM.	Defective FRAM, repair unit, replacement unit.	Check the setup data and correct, if necessary.
Warning: 8b ¹⁾ Update ext.Dat.		Transmitter has detected an error in the external FRAM and has repaired the data with content of the internal FRAM.	Defective FRAM or data was modified.	Check the setup data and correct, if necessary.
Warning: 9a Overflow > F	5	Forward totalizer has reached the maximum count and has restarted at zero.	Max. totalizer value up-scaled, 1 Reset totalizer, if necessary.	Reset totalizer, if necessary.
Warning: 9b Overflow < R	6	Reverse totalizer has reached the maximum count and has restarted at zero.	Max. totalizer value up-scaled, 1 Reset totalizer, if necessary.	Reset totalizer, if necessary.
Warning: 9c Overflow Diff.	7	The difference totalizer has reached the maximum count and has restarted at zero.	Max. totalizer value up-scaled, 1 Reset totalizer, if necessary.	Reset totalizer, if necessary.

1) Warning is displayed for 30 seconds.

... 9 Diagnosis / error messages

... Warning messages during operation

Warning code and ID letter	Priority	Description	Possible cause	Corrective action
Warning: 10 Reverse Q	8	If the flow direction is forward, the warning is displayed in case of reverse flow.	Reverse flow direction, possibly defective damper or check valve.	Prevent reverse flow or change flow direction to forward/reverse.
Warning: 11 ²⁾ Poll. Adr. > 0	12	The HART device address was changed to an address other than zero. The current output remains frozen at 4 mA.	Address 1 to 15 selected. The current output thereby remains set at 4 mA.	Select 0 as address, if the current output should be 4 to 20 mA.
Warning: 12a ^{2) 3)} Simulation lout	13	Test the current output. Check the value set at the terminals using a digital voltmeter or the process instrumentation.	Enter the functional test of the current output directly in mA for simulation.	Exit the functional test of current output.
Warning: 12b ^{2) 3)} Simulat. Pulses	14	Test the pulse output. Check the configured pulse at the output with a meter.	Simulation pulse output on.	Exit the functional test for the pulse output.
Warning: 13 ^{2) 3)} Auto. Calibration	15	Adjustment started for system zero point adjustment via the contact input for internal adjustment (for ABB Service only).	The external contact is closed For ABB Service personnel only.	The external contact is open again. For ABB Service personnel only.
Warning: 14 Hold MW	16	Warning results only when the 'Noise reduction' function is activated.	Measuring signal affected by powerful interference signal.	Reduce interference to lower level or shut off. Where applicable, Consult with the factory service department.
Warning 15 Warn. Diagnosis	17	Diagnostic or wiring warning	Min-Max over/undershoot for diagnostic values. Wiring error for electrode circuit. Coil short-circuit to ground	Retrieve details of warning message under the Status submenu in the Diagnosis warning register. Where applicable, Adjust limit value. Retrieve details of warning message under the Status submenu in the Wiring warning register.

2) Transmitter must be equipped with HART communication protocol.

3) Warning is displayed only if the function is called by an external HART protocol command.

10 Maintenance / Repair

Safety instructions

WARNING

Risk of injury due to live parts!

When the housing is open, contact protection is not provided and EMC protection is limited.

- Before opening the housing, switch off the power supply.

CAUTION

Risk of burns due to hot measuring media

The device surface temperature may exceed 70 °C (158 °F), depending on the measuring medium temperature!

- Before starting work on the device, make sure that it has cooled sufficiently.

NOTICE

Damage to components!

The electronic components of the printed circuit board can be damaged by static electricity (observe ESD guidelines).

- Make sure that the static electricity in your body is discharged before touching electronic components.

Repair and maintenance activities may only be performed by authorized customer service personnel.

When replacing or repairing individual components, original spare parts must be used.

NOTICE

Caution - Potential damage to parts!

The electronic components of the printed circuit board can be damaged by static electricity (observe ESD guidelines). Make sure that the static electricity in your body is discharged when touching electronic components.

Sensor

Essentially no maintenance is required for the sensor. The following items should be checked annually:

- Ambient conditions (air circulation, humidity),
- Tightness of the process connections,
- Cable entries and cover screws,
- Operational reliability of the power supply, lightning protection, and station ground.

The flowmeter sensor electrodes must be cleaned when the flowrate information on the transmitter changes when recording the identical flowrate volume. If the display shows a higher flowrate, the contamination is insulating. If the flowrate displayed is lower, the contamination results in a short-circuit. For repairs to the lining, electrodes or magnet coil, the flowmeter must be returned to the head office in Göttingen.

Note

When sending the sensor for repair to the head office of ABB AG, complete the return form in the appendix and include with device.

When cleaning the exterior of measuring devices, make sure that the cleaning agent used does not corrode the housing surface and the gaskets.

Gaskets

Some device designs are shipped with special gaskets. These gaskets must be used and installed properly to prevent leakage. For all other device designs, use commercially available gaskets made from a compatible material for the measuring medium and prevailing temperature (rubber, PTFE, It, EPDM, silicon, Viton, etc.) or use 'Hygienic Design' compliant gasket materials for hygienic devices.

Note

A wafer type sensor is installed without gaskets directly in the pipeline.

... 10 Maintenance / Repair

Replacing the transmitter

The transmitter plug-in unit can be replaced without loss of function for nominal diameters DN 3 to DN 1000.

When replacing the FRAM-calibrated flowmeter sensor (identifiable by the Cs and Cz values on the name plate), please take into consideration the following points:

- Does the replacement transmitter plug-in unit use the same power supply?
- Does the replacement transmitter plug-in unit have the same input/output functions or use the same type of communication?

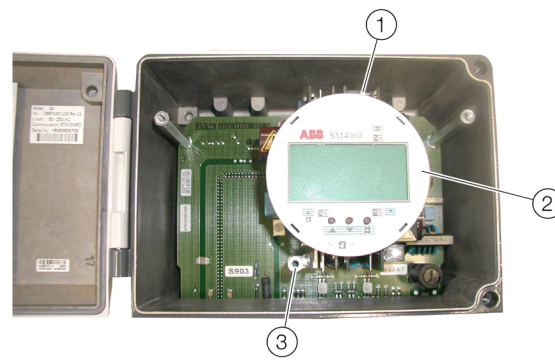

- ① Fixing screw for plug-in unit
- ② Transmitter plug-in unit
- ③ Stud bolt for plug-in unit

Figure 55: Disassembling the transmitter plug-in unit

⚠ WARNING

Warning - Electrical dangers!

When the housing is open, EMC protection is impaired and there is no longer any protection against accidental contact.

- Power to all connection leads must be switched off.

1. Switch off the power supply before installing the replacement transmitter plug-in unit. After waiting 40 minutes, remove the housing cover from the field housing unit. First, remove the shock protection covers (3 screws). Next, remove the upper mounting screw and the center stay-bolt on the plug-in. The plug-in module can now be pulled up and off the connection plug. Install the replacement transmitter plug-in in reverse order.

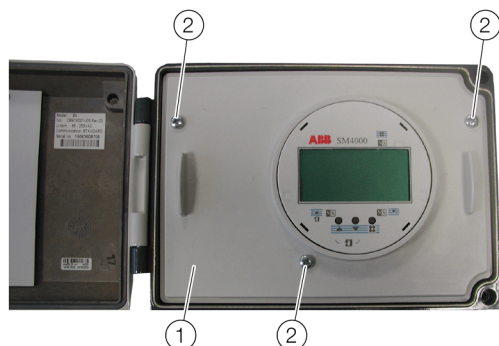

- ① Shock protection cover
- ② Fixing screw cover

Figure 54: Removing the shock protection cover

2. Power-up the power supply; the model number for the transmitter and the current software revision are displayed. The flowmeter sensor and system data from the external FRAM are imported:
 - a) The following information is displayed:
 - Warning 7 – External data is loaded.
When replacing the transmitter all flowmeter sensor and measuring point parameters are imported by the replacement transmitter. After successful data transfer, the 'Warning 7' message is deleted after approx. 30 sec.
 - b) Transmitter and sensor are recommissioned (e.g., after a power failure):
No warning is displayed; the transmitter runs automatically with the data from the internal and external FRAM.
 - c) Only the transmitter is replaced; order numbers are not identical. The external sensor and system data is imported. The following message is displayed:
 - Warning 7 – External data is loaded.
 - d) If the order number, unit number, Cs, Cz and nominal diameter are identical (e.g., if the transmitter is used from a delivery with identical configuration data), the process data is imported from the internal to external FRAM. The sensor data continues to be imported from the external to internal FRAM. The following message is displayed:
 - Warning 8b – (Update external data).

If the external data cannot be loaded in scenarios a) to d), the program attempts to repair the defective data. The following messages may be displayed:

- Warning 8a – (Update internal data) - for data flow direction external → internal
- Warning 8b – (Update external data) - for data flow direction internal → external

Both messages can be displayed simultaneously.

If this occurs, the following error is displayed:

- Error C – for the external FRAM, the FRAM thus must be replaced
 - Error 5 – for the internal FRAM, the transmitter starts automatically with default values. In some instances, it may be possible to eliminate this error by turning the supply power off and on. If the error does not disappear, the transmitter or the transmitter plug-in unit must be replaced.
3. Check whether the language, display format, measuring ranges, limit values and sensor data match the values listed on the name plate of the sensor. If parameters are subsequently changed, these are stored automatically in the external FRAM.
 4. The measuring system is ready for operation.

Returning devices

Use the original packaging or a secure transport container of an appropriate type if you need to return the device for repair or recalibration purposes.

Fill out the return form (see **Return form** on page 119) and include this with the device.

In accordance with the EU Directive governing hazardous materials, the owner of hazardous waste is responsible for its disposal or must observe the following regulations for shipping purposes:

All devices delivered to ABB must be free from any hazardous materials (acids, alkalis, solvents, etc.).

Address for returns:

Please contact Customer Center Service acc. to page **Fehler! Textmarke nicht definiert.** for nearest service location.

11 Recycling and disposal

Dismounting

WARNING

Risk of injury due to process conditions.

The process conditions, for example high pressures and temperatures, toxic and aggressive measuring media, can give rise to hazards when dismantling the device.

- If necessary, wear suited personal protective equipment during disassembly.
- Before disassembly, make sure that the process conditions do not pose any safety risks.
- Depressurize and empty the device / piping, allow to cool and purge if necessary.

Bear the following points in mind when dismantling the device:

- Switch off the power supply.
- Disconnect electrical connections.
- Allow the device / piping to cool and depressurize and empty. Collect any escaping medium and dispose of it in accordance with environmental guidelines.
- Use suited tools to disassemble the device, taking the weight of the device into consideration.
- If the device is to be used at another location, the device should preferably be packaged in its original packing so that it cannot be damaged.
- Observe the notices in **Returning devices** on page 13.

Disposal

Note



Products that are marked with the adjacent symbol may **not** be disposed of as unsorted municipal waste (domestic waste).

They should be disposed of through separate collection of electric and electronic devices.

This product and its packaging are manufactured from materials that can be recycled by specialist recycling companies.

Bear the following points in mind when disposing of them:

- As of 8/15/2018, this product will be under the open scope of the WEEE Directive 2012/19/EU and relevant national laws (for example, ElektroG - Electrical Equipment Act - in Germany).
- The product must be supplied to a specialist recycling company. Do not use municipal waste collection points. These may be used for privately used products only in accordance with WEEE Directive 2012/19/EU.
- If there is no possibility to dispose of the old equipment properly, our Service can take care of its pick-up and disposal for a fee.

12 Spare parts list

Note

Spare parts can be ordered from ABB Service.

www.abb.com/contacts

Fuses for transmitter electronics

⚠ WARNING

Danger due to electric current!

When the housing is open, EMC protection is impaired and there is no longer any protection against accidental contact.

- Power to all connection leads must be switched off.

Replacing the fuse

1. Switch off the power supply. After waiting 40 minutes, remove the housing cover from the field housing unit.
2. To replace the fuses for shock protection cover ①, loosen and remove the 3 screws ②.

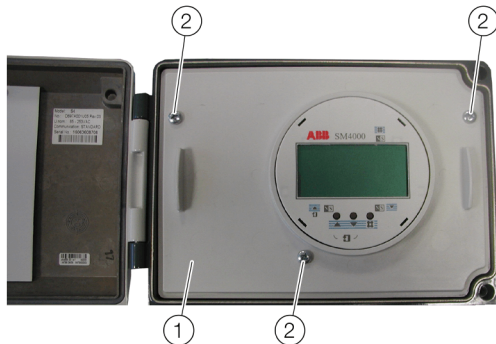

- ① Shock protection cover
- ② Fixing screw cover

Figure 56: Removing the shock protection cover

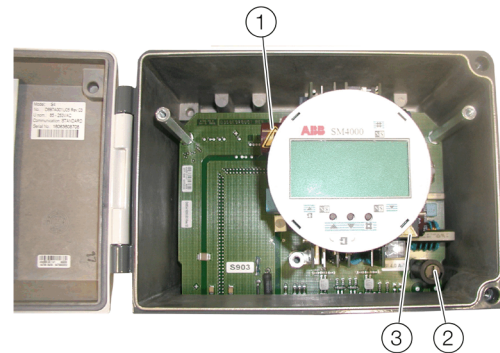

- ① Fuse for driver circuit on the backplane
- ② Backup fuse for power supply on the backplane
- ③ Fuses for power supply on the transmitter electronics

Figure 57: Fuses

Item	Designation	Ordering number
①	Driver circuit fuse F103 (0.8 A)	D151F003U18
②	Backup fuse for power supply on backplane (4 A-T)	D151B003U08
③	Fuse for power supply on the transmitter electronics	
	Fuse for 24 V AC/DC (4 A-T)	D151B003U08
	Fuse for 100 to 230 V AC (1 A-T)	D151B003U05

... 12 Spare parts list

Spare parts for transmitter S4

Field mount housing

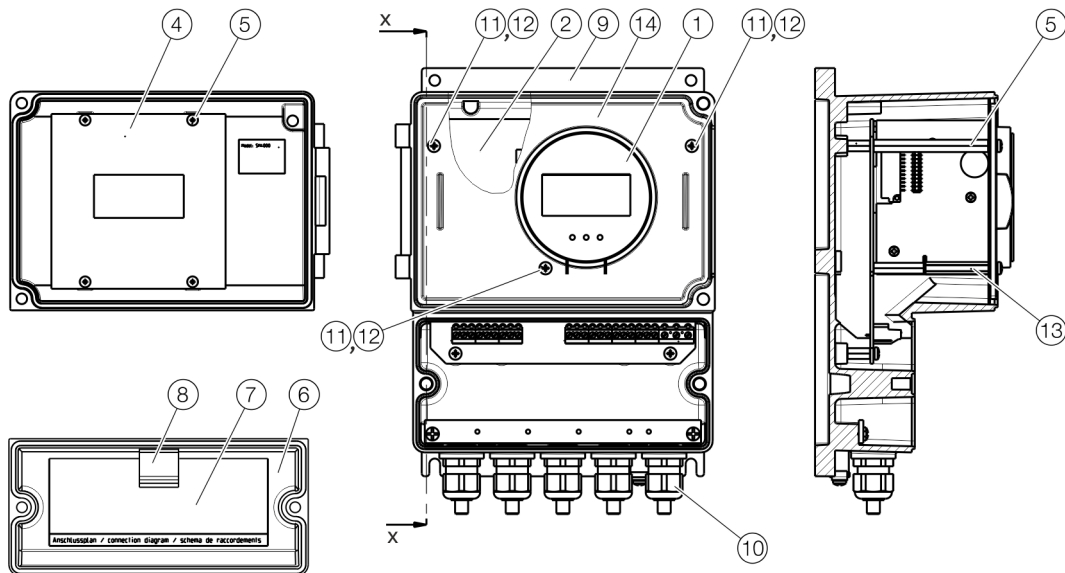

Figure 58: Field mount housing

Item	Designation	Ordering number
①	Transmitter (100 to 230 V AC) without HART Transmitter (100 to 230 V AC) with HART Transmitter (24 V AC/DC) without HART Transmitter (24 V AC/DC) with HART	3KXF002961U0100 3KXF002961U0200 3KXF002961U0100 3KXF002961U0200
②	Connection board, standard Connection board, PA/FF	D685A1020U01 D685A1020U02
③	Large cover, complete	D641A030U01
④	PVC cover	D626A005U01
⑤	Spacer bolts M4 × 75, galvanized steel	D124E009U20
⑥	Small cover	D641A029U01
⑦	Connection diagram, standard / HART	D338D311U01
⑧	Flat cable holder	D174D002U03
⑨	Field housing unit, empty	D641A033U01
⑩	Cable gland M 20 × 1.5	D150A008U15
⑪	Pan head Phillips screw M4 × 10, galvanized steel	D004G108AU01
⑫	Spring washer A 4.0 DIN 137, Niro	D085D020AU20
⑬	Spacer bolts M4 x 41 I/A, galvanized steel	D403B104U01
⑭	Shock protection cover	D355H305U01

1) When ordering spare parts, please provide the communication version to help us select the proper software.

Spare parts for sensor

Terminal box stainless steel DN 3 to DN 100

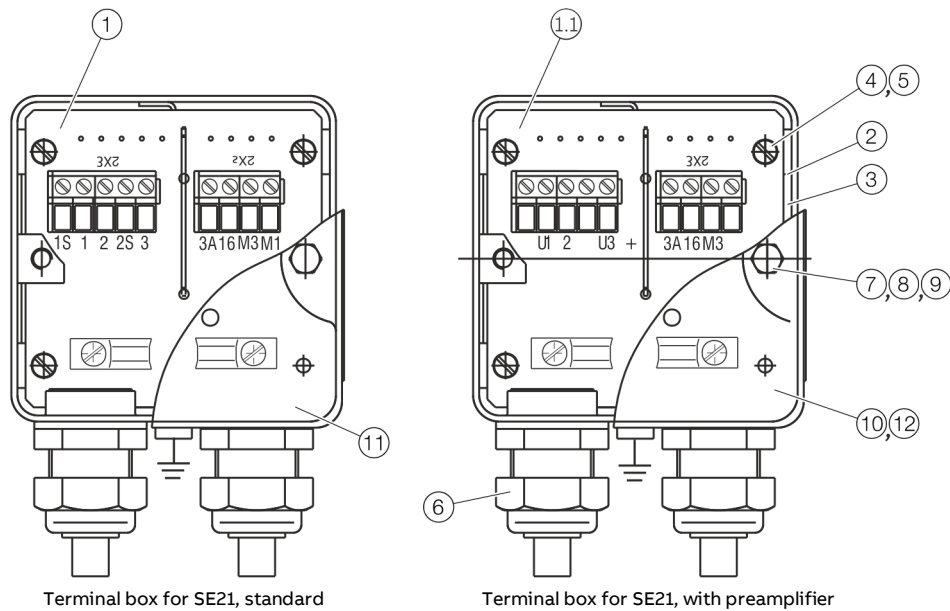

Figure 59: Stainless steel terminal box

Item	Designation	Ordering number
①	Terminal board standard > D N8	D685A1025U01
①.1	Connection board with preamplifier	D685A1028U01
②	Lower section SS 1.4301, model SE21_	D612A128U01
③	Seal	D333F016U01
④	Pan head screw M3 × 6, DIN 7985	D004F106AU20
⑤	Serrated lock washer A3.2, DIN 6798	D085G017AU32
⑥	Cable gland, plastic, grey	D150A008U02
⑦	Spacer	D375A018U01
⑧	Hexagon head screw M4 × 14, DIN 7964, stainless steel	D024G110AU20
⑨	Insert ring 'Nyltite Seal' F.M4	D115B004U01
⑩	Cover SS no. 1.4301	D612A178U01
⑪	Connection diagram, standard	D338D309U01
⑫	Connection diagram, with preamplifier	D338D310U01

... 12 Spare parts list

... Spare parts for sensor

Terminal box, aluminum DN 3 to DN 1000

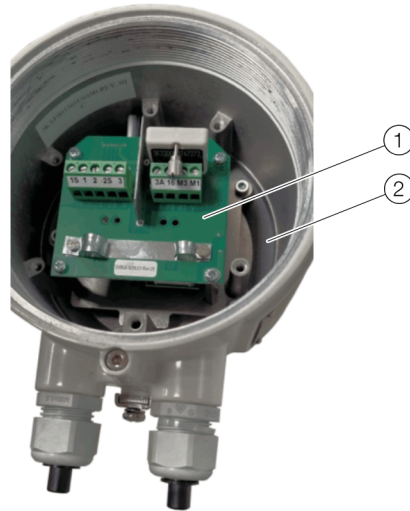

Figure 60: Aluminum terminal box

Item	Designation	Ordering number
①	Connection board, standard > DN 8	D685A1025U01
	Terminal board with preamplifier, type A	D685A1028U01
②	Terminal box with cable gland M20×1.5	3KXF000112U0100
—	Cover for terminal box	D612A226U01

13 Specification

Note

The device data sheet is available in the ABB download area at www.abb.com/flow.

Measuring accuracy

Reference conditions in accordance with EN 29104

Measuring medium temperature	20 °C (68 °F) ±2 K
Ambient temperature	20 °C (68 °F) ±2 K
Power supply	Nominal voltage as per name plate UN ± 1 %
Installation conditions	<ul style="list-style-type: none"> Inlet section: <ul style="list-style-type: none"> > 10 × DN straight section Outlet section: <ul style="list-style-type: none"> > 5 × DN straight section DN = Sensor nominal diameter
Warm-up phase	30 min

Maximum measuring error

Pulse output

- DN 3 to DN 1000 (1/10 to 40"):
 - $Q > 0.05 Q_{max}DN \pm 0.5 \%$ of measured value
 - $Q < 0.05 Q_{max}DN \pm 0.00025 Q_{max}DN$

$Q_{max}DN$ = maximum flow rate of the nominal diameter at 10 m/s

Analog output effects

Same as pulse output plus ±0.1 % of measured value ±0.01 mA

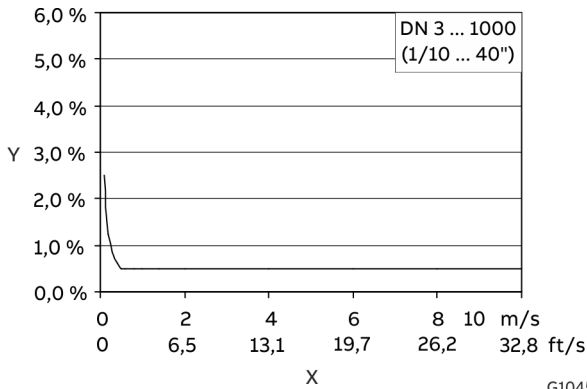

Y Measured error ± of measured value
 X Flow velocity v

Figure 61: Analog output effects

Sensor SE41F

Temperature graph

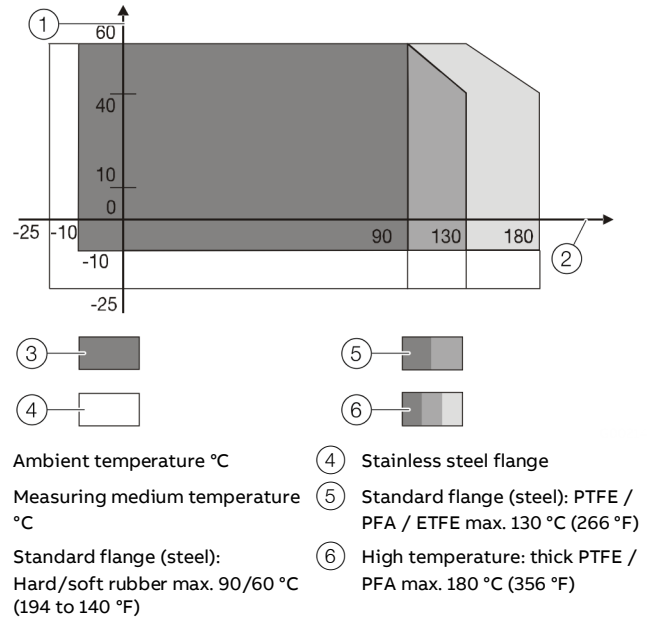

Figure 62: Measuring medium temperature dependent on the ambient temperature

Max. permissible cleaning temperature PTFE-, PFA-design

CIP cleaning	Liner Flowmeter sensor	T_{max}	$t_{max} Min$	$T_{amb.}$
Steam cleaning	PTFE, PFA	150 °C (302 °F)	60	25 °C (77 °F)
Wet cleaning	PTFE, PFA	140 °C (284 °F)	60	25 °C (77 °F)

If the ambient temperature is > 25 °C, the difference must be subtracted from the max. cleaning temperature.

$$T_{max} - \Delta \text{ °C} \cdot \Delta \text{ °C} = (T_{amb.} - 25 \text{ °C})$$

... 13 Specification

... Sensor SE41F

Min. permissible pressure as a function of measuring medium temperature

Liner	Nominal diameter DN	P _{Betrieb} mbar abs	at	T _{Betrieb}
Hard rubber	15 to 1000 (1/2 to 40")	0		< 90 °C (194 °F)
Soft rubber	50 to 1000 (2 to 40")	0		< 60 °C (140 °F)
PTFE	10 to 600 (3/8 to 24")	270		< 20 °C (68 °F)
		400		< 100 °C (212 °F)
		500		< 130 °C (266 °F)
Thick PTFE high temperature design	25 to 80 (1 to 3") 100 to 250 (4 to 10") 300 (12")	0		< 180 °C (356 °F)
		67		< 180 °C (356 °F)
PFA	3 to 200 (1/10 to 8")	0		< 130 °C (266 °F)
		0		< 180 °C (356 °F)
ETFE	25 to 1000 (1 to 40")	100		< 130 °C (266 °F)
Ceramic carbide	25 to 1000 (1 to 40")	0		< 80 °C (176 °F)

Sensor material

Parts	Standard	Others
Liner	PTFE, PFA, hard rubber, soft rubber, ETFE	Ceramic carbide
Signal and ground electrode for • Hard rubber • Soft rubber	Stainless steel 1.4571 (316 Ti)	Hastelloy B-3 (2.4600), Hastelloy C-4 (2.4610), titanium, tantalum, platinum-iridium, stainless steel 1.4539 (904 L)
• PTFE, PFA, ETFE	Hastelloy C-4 (2.4610)	Stainless steel 1.4571 (316 Ti), Hastelloy B-3 (2.4600), titanium, tantalum, platinum- iridium, stainless steel 1.4539 (904 L)
Grounding plate	Stainless steel 1.4571 (316 Ti)	On request
Protection plate	Stainless steel 1.4571 (316 Ti)	On request

Process connection material

Parts	Standard	Others
Flange		
DN 3 to DN 15 (1/10 to 1/2")	stainless steel*	stainless steel*
DN 20 to DN 300 (3/4 to 12")	Steel galvanized**	
DN 350 to DN 1000 (14 to 40")	Steel painted**	
Chassis		
DN 3 to 300 (1/10 to 12")	Pair case cast aluminum, painted, paint coat, ≥ 80 µm thick, RAL 9002	—
DN 350 to DN 1000 (14 to 40")	Steel welded construction, painted, paint coat, ≥ 80 µm thick, RAL 9002	—
Terminal box	Aluminum alloy, painted, ≥ 80 µm thick, frame: dark gray, RAL 7012 Cover: light gray, RAL 9002	—
Meter tube	Stainless steel 1.4301 (304)	—
Cable gland	Polyamide	—

The process connections are made of one of the materials listed below:

- * 1.4301 (304), 1.4307, 1.4404 (316L), 1.4435 (316L), 1.4541 (321), 1.4571 (316Ti), ASTM A182 F304, ASTM A182 F304L, ASTM A182 F316L, ASTM A182 F321, ASTM A182 F316Ti, ASTM A182 F316, 0Cr18Ni9, 0Cr18Ni10, 0Cr17Ni13Mo2, 0Cr27Ni12Mo3, 1Cr18Ni9Ti, 0Cr18Ni12Mo2Ti
- ** 1.0038, 1.0460, 1.0570, 1.0432, ASTM A105, Q255A, 20#, 16Mn

Storage temperature

-20 to 70 °C (-4 to 158 °F)

IP rating in accordance with EN 60529

IP 65/IP 67

IP 68 (option)

Pipe vibration according to EN 60068-2-6**Transmitter**

- In the range of 10 to 55 Hz, max. deflection 0.15 mm

Sensor

- In the range of 10 to 55 Hz, max. deflection 0.15 mm
- In the range of 10 to 55 Hz, max. acceleration 2 g

Designs

The flange devices are compliant with the installation lengths determined according to ISO 13359.

Material loads for process connections

The limits of the permissible measuring medium temperature (T_{medium}) and permissible pressure (P_{medium}) are calculated on the basis of the liner and flange material used in the device (see device name plate).

Temperature limits

Liner	Flange material	Min. temperature	Max. temperature	
			Standard	High temperature
Hard rubber	Steel	-10 °C (14 °F)	90 °C (194 °F)	—
	Stainless steel	-15 °C (5 °F)	90 °C (194 °F)	—
Soft rubber	Steel	-10 °C (14 °F)	60 °C (140 °F)	—
	Stainless steel	-15 °C (5 °F)	60 °C (140 °F)	—
PTFE / ETFE	Steel	-10 °C (14 °F)	130 °C (266 °F)	—
	Stainless steel	-25 °C (-13 °F)	130 °C (266 °F)	—
Thick PTFE / PFA	Steel	-10 °C (14 °F)	130 °C (266 °F)	180 °C (356 °F)
	Stainless steel	-25 °C (-13 °F)	130 °C (266 °F)	180 °C (356 °F)
Ceramic carbide	Steel	-10 °C (14 °F)	80 °C (176 °F)	—
	Stainless steel	-20 °C (-4 °F)	80 °C (176 °F)	—

... 13 Specification

... Sensor SE41F

Devices with DN 3 to 600 (1/10 to 24 in)

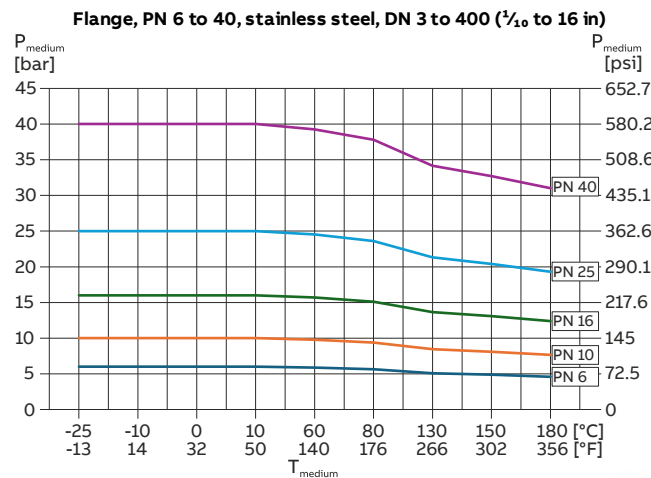
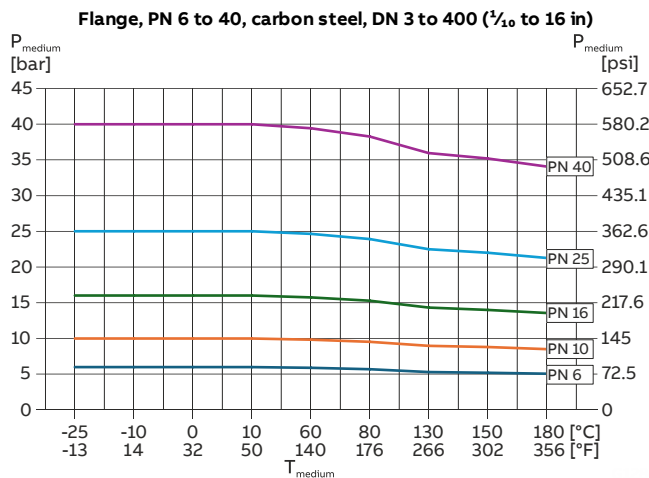

Figure 63: Flowmeter sensor with carbon steel flange or stainless steel flange, Nominal Diameter DN 3 to 400, Pressure Rating PN 6 to 40

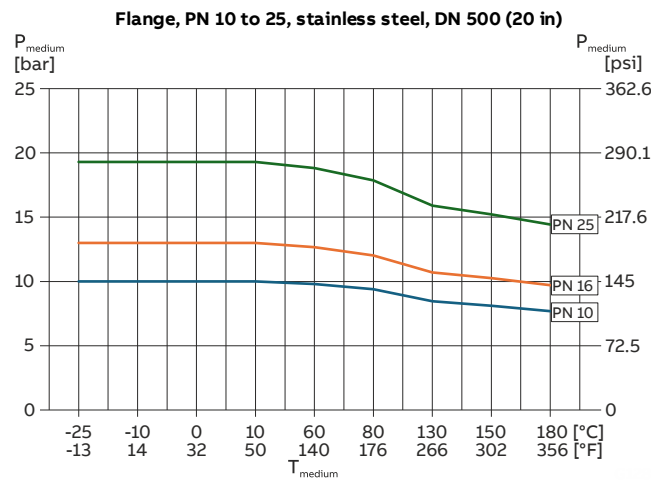
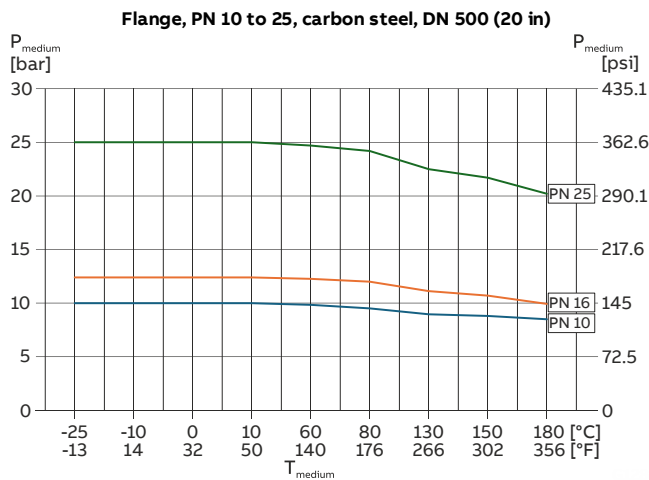

Figure 64: Flowmeter sensor with carbon steel flange or stainless steel flange, Nominal Diameter DN 500, Pressure Rating PN 10 to 25

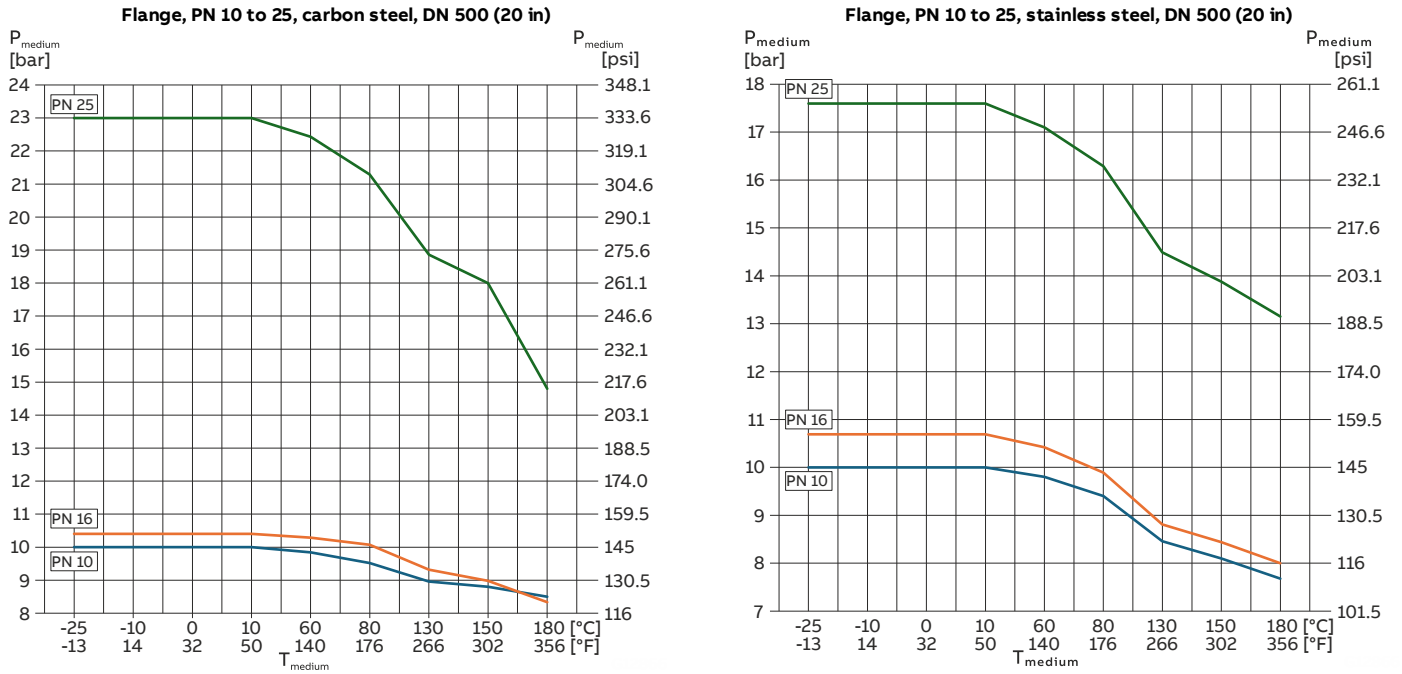

Figure 65: Flowmeter sensor with carbon steel flange or stainless steel flange, Nominal Diameter DN 500, Pressure Rating PN 10 to 25

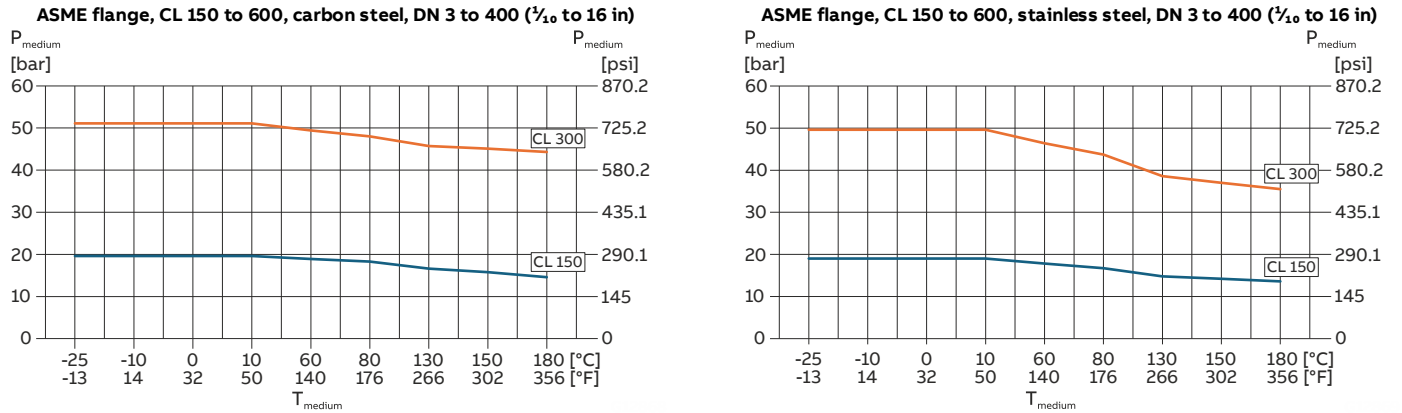
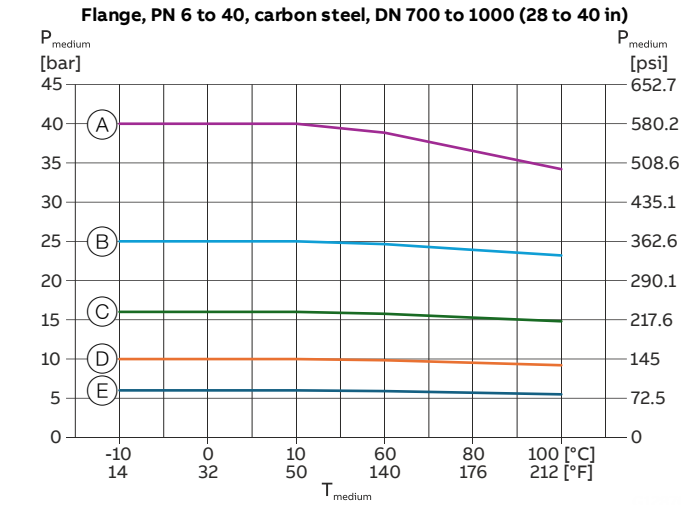

Figure 66: Flowmeter sensor with carbon steel flange or stainless steel flange, Nominal Diameter DN 3 to 400 (1/2 to 24 in), Pressure Rating CL 150 to 600

... 13 Specification

... Sensor SE41F

Devices with DN 700 to 1000 (28 to 40 in)



- (A) DN 700 to 1000 (28 to 40 in), PN 40
- (B) DN 700 to 1000 (28 to 40 in), PN 25
- (C) DN 700 to 1000 (28 to 40 in), PN 16
- (D) DN 700 to 1000 (28 to 40 in), PN 10
- (E) DN 1000 (40 in), PN 6

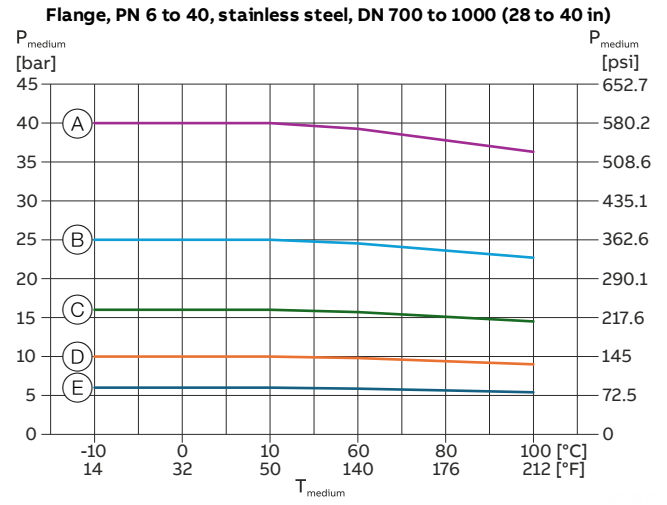

- (A) DN 700 to 1000 (28 to 40 in), PN 40
- (B) DN 700 to 1000 (28 to 40 in), PN 25
- (C) DN 700 to 1000 (28 to 40 in), PN 16
- (D) DN 700 to 1000 (28 to 40 in), PN 10
- (E) DN 1000 (40 in), PN 6

Figure 67: Flowmeter sensor with carbon steel flange or stainless steel flange, nominal diameter DN 700 to 100 (28 to 40 in), pressure Rating PN 6 to 40

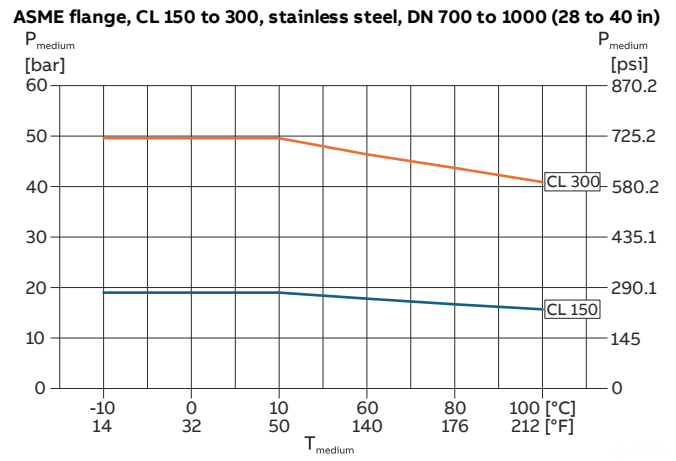
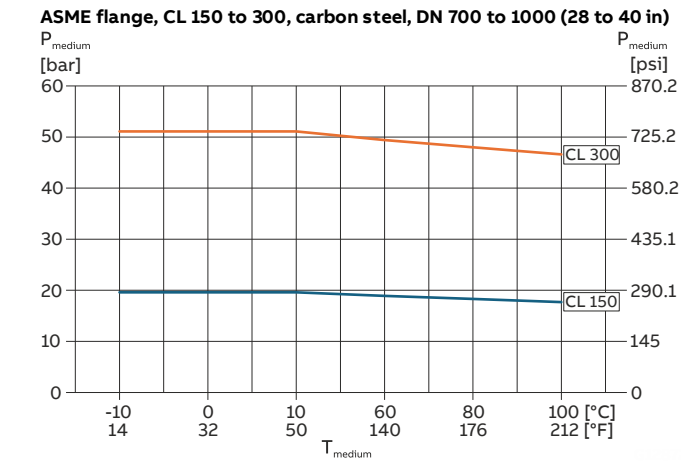

Figure 68: Flowmeter sensor with carbon steel flange or stainless steel flange, nominal diameter DN 700 to 1000 (28 to 40 in), pressure Rating CL 150 to 300

Devices in high pressure design, DN 25 to 400 (¾ to 16 in), pressure rating PN 63 to 100 (CL 600)

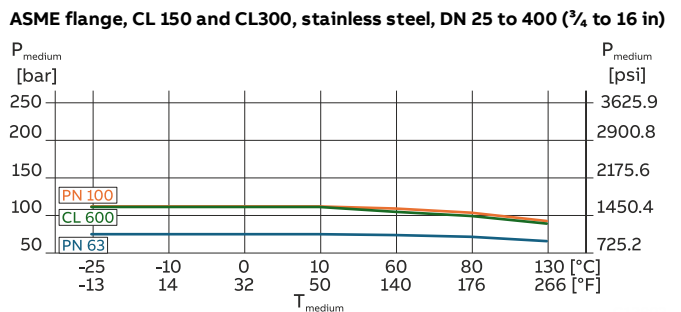
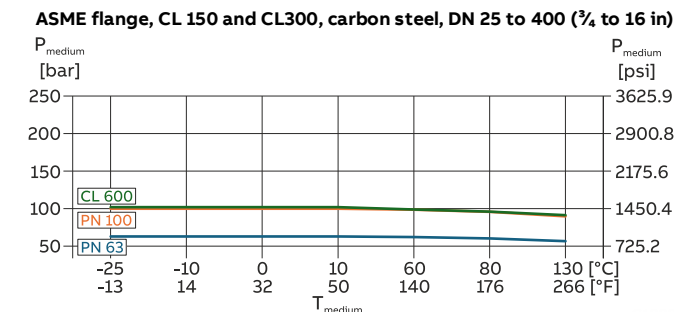

Figure 69: Flowmeter sensor with carbon steel flange and stainless steel flange, nominal diameter DN 25 to 400 (¾ to 16 in), high pressure design

Sensor SE21_

Minimum permissible absolute pressure

Liner	Nominal diameter DN	P _{Betrieb} mbar abs	at	T _{Betrieb} ¹⁾ °C
PFA	3 to 100 (1/10 to 4")	0	≤	130 °C (266 °F)

1) For CIP/SIP cleaning, higher temperatures are permitted for limited time periods; refer to the table entitled 'Maximum permissible cleaning temperature'.

Maximum permissible cleaning temperature

CIP cleaning	Liner	T _{max}	T _{max} Minutes	T _{amb.}
Steam cleaning	PFA	150 °C (302 °F)	60	25 °C (77 °F)
Wet cleaning	PFA	140 °C (284 °F)	60	25 °C (77 °F)

If the ambient temperature is > 25 °C (77 °F), then the difference must be subtracted from the max. cleaning temperature.

$$T_{\max} - \Delta \text{ } ^\circ\text{C}, \Delta \text{ } ^\circ\text{C} = (T_{\text{amb}} - 25 \text{ } ^\circ\text{C})$$

Maximum Allowable Temperature Shock

Lining	Temp shock max. temp. diff. °C	Temp. gradient °C/min
PFA	Any	Any

Maximum permissible ambient temperature as a function of measuring medium temperature

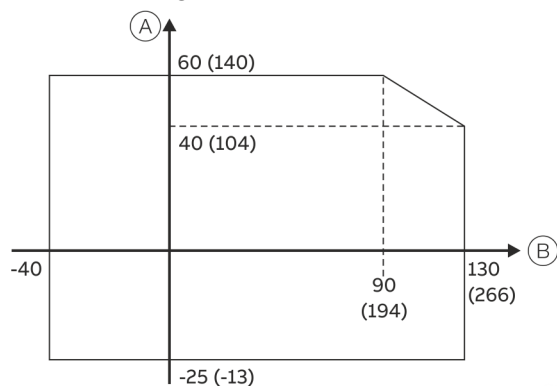

(A) Ambient temperature T_{amb.}

(B) Measuring medium temperature T_{medium}

Figure 70: Temperature graph

Sensor material

Liner	Electrode material		Electrode design	
	Standard	Others	Standard	Others
PFA	Hast.-C4 (2.4610), 1.4539 (904 L), 1.4571 (316 Ti), Titanium, Tantalum, Platinum- iridium	Hast.-B3 (2.4600), 1.4539 (904 L)	Flat head	Pointed head (≥ DN 10) 1.4539, (904 L)

Process connection material

Process connection	Standard
Wafer type	without
Terminal box	
• without/with preamplifier, type A	Stainless steel 1.4301 (304)
• with preamplifier, type B	Aluminum alloy, painted, paint coat frame: dark gray, RAL 7012 cover: light gray, RAL 9002
Meter tube	Stainless steel 1.4301 (304)
Cable gland	Polyamide
Flowmeter sensor housing	Stainless steel 1.4301 (304)

Storage temperature

-25 to 70 °C (-13 to 158 °F)

IP rating in accordance with EN 60529

- IP 67
- IP 68 (Option)

Pipe vibration according to EN 60068-2-6

Transmitter

- In the range of 10 to 55 Hz, max. deflection 0.15 mm

Sensor

- In the range of 10 to 55 Hz, max. deflection 0.15 mm
- In the range of 10 to 55 Hz, max. acceleration 2 g

... 13 Specification

... Sensor SE21_

Material loads for process connections

The limits of the permissible measuring medium temperature (T_{medium}) and permissible pressure (P_{medium}) are calculated on the basis of the liner and flange material used in the device (see device name plate).

Devices with variable process connections / wafer type SE21 DN 3 to 100 (1/16 to 4 in)

Process connection	Nominal diameter	PS _{max}	TS _{min}	TS _{max}
PFA liner	DN	Bar (psi)		
Wafer type	3 to 50	40	-40 °C (-40 130 °C (266 °F)	°F
	(1/16 to 2 in)	(580.2)		
	65 to 100	16		
	(2 1/2 to 4 in)	(232.1)		

Material load for wafer type design model SE21W

Liner: PFA wafer type

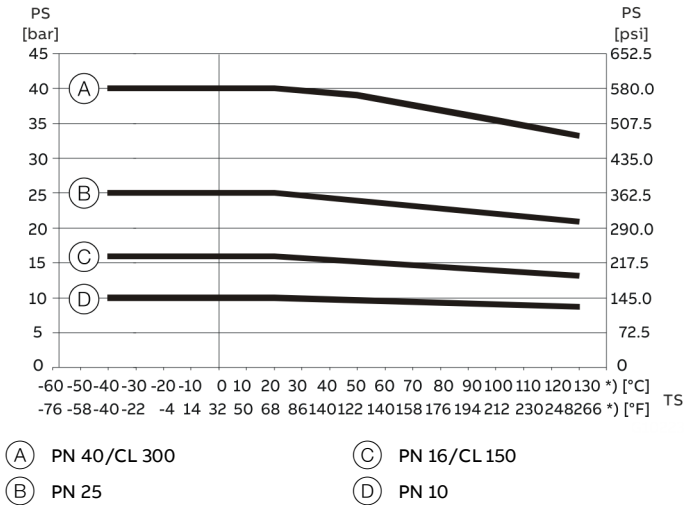

Figure 71: Wafer type design model SE21W

*) Higher temperatures are allowed for CIP/SIP cleaning for limited time periods, see Table 'Maximum permissible cleaning temperature'.

Transmitter

Meas. range	Any flow range whose 100% value corresponds to a flow velocity between 0.5 m/s and 10 m/s can be selected.	
Minimum conductivity	≥ 20 μS/cm standard	DN 10 to DN 1000 (3/8 to 40")
	≥ 20 μS/cm with preamplifier	DN 3 to DN 8 (1/25 to 5/16")
	≥ 5 μS/cm with preamplifier	DN 3 to 1000 (1/25 to 40")
	≥ 0.5 μS/cm with preamplifier	DN 10 to DN 1000 (3/8 to 40")
Repeatability	DN 3 to 1000 (1/10 to 40"):	
(measurement period = 100 s)	≤ ± (0.1 % of measured value + 0.01 % of Q _{max, DN})	
Response time	1τ = 70 ms (0 to 66 %) Fast operating mode	
	1τ = 200 ms (0 to 66 %) Standard/piston pump operating mode	
Power supply	U = 100 to 230 V, 50/60 Hz	
	U _{rat} = 85 to 253 V, 50/60 Hz	
	50/60 Hz ± 6%	
	20.4 to 26.4 V AC, 20.4 to 31.2 V DC, ripple ≤ 5 %	
Power consumption	S ≤ 45 VA (sensor including transmitter)	
Ambient temperature	-20 to 60 °C (-4 to 140 °F)	
Storage temperature	-20 to 80 °C (-4 to 176 °F)	

IP rating in accordance with EN 60529

IP 67 for field-mount housing and NEMA 4X

Relative humidity

Acc. to IEC 60068-2-30 classification of environmental conditions, natural factors, temperature and air humidity.

No effect under the following operating conditions: temperature ranging from 25 to 55 °C (77 to 131 °F) and a relative air humidity of 94 to 97 %.

14 Additional documents

Note

All documentation, declarations of conformity, and certificates are available in ABB's download area.

www.abb.com/flow

Vibration

In accordance with IEC 60068-2-6 (03/95), grouping of devices according to table C2 for general industry applications. No additional effect on the following levels of vibration. Frequency range 10 to 55 Hz; amplitude max. 0.15 mm.

Design

Field-mount housing made of cast aluminum per DIN 1725, painted.

Paint coat thickness 80 µm. Lower section (RAL 7012), upper section (RAL 9002). For dimensions, see **Dimensions** in the Datasheet. Weight, approx. 3.3 kg.

Signal cable

Max. cable length between flowmeter sensor and transmitter is:

- 50 m for the standard design and versions with automatic zero return, from DN 10 (3/8") and from 20 µS/cm.
- 200 m for designs with preamplifier.

A 5 m signal cable is included with each flowmeter. If a cable longer than 5 m is required, refer to the ordering information for the sensor.

Coil supply cable

Is required to connect the flowmeter sensor to the transmitter. For EMC reasons, the 2-wire cable is shielded. A 5 m cable is included with each flowmeter. If a cable longer than 5 m is required, refer to the ordering information for the sensor.

Trademarks

HART is a registered trademark of FieldComm Group, Austin, Texas, USA

15 Appendix

Overview of setting parameters and technical design

Measuring point:		TAG no.:
Sensor model:		Transmitter type:
Order no.:	Device no.:	Order no.:
Measuring medium temperature:		Voltage supply:
Lining:	Electrodes:	Exciter frequency:
C _{zero} :	C _{Span} :	System zero point:

Parameter	Adjustment range
Prog. Protection code:	0-9999 (0 = factory setting)
Language:	e.g., German, English, French, etc.
Flowmeter sensor	see name plate or the submenu 'System Data/Sensor'
Nominal size:	DN 1 to DN 1000
Q _{max} :	0.05 Q _{max} DN to 1 Q _{max} DN
Pulse factor:	Imp./phys. Unit
Pulse width:	0.100 to 2000 ms
Offset suppression:	0 to 10 % of upper range value
Damping:	0.2 (0.07) to 20 seconds
Noise reduction	OFF / 1 / 2 / 3 / 4
Density:	0.01 g/cm ³ to 5.0 g/cm ³
Unit Q _{max} :	e.g., l/s, l/min, l/h, hl/s, hl/min, hl/h, etc.
Unit totalizer:	e.g. l, hl, m ³ , igital, gal etc.
Max. alarm:	%
Min. alarm:	%
Switching output:	Max. Alarm, Min. Alarm, Max./Min. Alarm, General alarm, empty conduit etc.
Contact input:	External zero return, Totalizer reset, External system zero, no function
Current output:	0/4 to 20 mA, 0/2 to 10 mA, 0 to 5 mA, 0 to 10-20 mA, 4 to 12 to 20 mA
I _{out} with alarm:	0 %, 103 %, 3.8 mA, Low, High
Detector e. pipe:	ON / OFF
Calibrate e. pipe:	0 to 10000
Alarm e. pipe:	ON / OFF
I _{out} for e. pipe:	0 %, 103 %, 3.8 mA, Low, High
Totalizer function:	Standard, difference totalizer
1. display line:	Q (%), Q (unit), Q (mA), counter V/R, TAG number, blank line, bar graph
2. display line:	Q (%), Q (unit), Q (mA), counter V/R, TAG number, blank line, bar graph
3. display line:	Q (%), Q (unit), Q (mA), counter V/R, TAG number, blank line, bar graph
4. display line:	Q (%), Q (unit), Q (mA), counter V/R, TAG number, blank line, bar graph
Operating mode:	Standard / Piston Pump / Fast
Flow direction:	Forward / reverse flow, Forward flow
Directional display:	Standard, inverse
Pulse output:	<input type="checkbox"/> Active <input type="checkbox"/> Passive
Communication:	<input type="checkbox"/> HART <input type="checkbox"/> Without
Diagnosis	Measured value E/W Min. Max. Measured value E/W Min. Max.
Threshold monitoring	Coil current AC Coil voltage DC
Error (E)	Coil resistance Coil temperature
Warning (W)	Coil insulation resistance DAC value
	Electrode voltage Electrode balance
	Signal-to-noise ratio Magnetic linearity

Return form

Statement on the contamination of devices and components

Repair and/or maintenance work will only be performed on devices and components if a statement form has been completed and submitted.

Otherwise, the device/component returned may be rejected. This statement form may only be completed and signed by authorized specialist personnel employed by the operator.

Customer details:

Company:

Address:

Contact person:

Telephone:

Fax:

Email:

Device details:

Type:

Serial no.:

Reason for the return/description of the defect:

Was this device used in conjunction with substances which pose a threat or risk to health?

Yes No

If yes, which type of contamination (please place an X next to the applicable items):

- | | | |
|--------------------------------------|---|---|
| <input type="checkbox"/> biological | <input type="checkbox"/> corrosive / irritating | <input type="checkbox"/> combustible (highly / extremely combustible) |
| <input type="checkbox"/> toxic | <input type="checkbox"/> explosive | <input type="checkbox"/> other toxic substances |
| <input type="checkbox"/> radioactive | | |

Which substances have come into contact with the device?

1.

2.

3.

We hereby state that the devices/components shipped have been cleaned and are free from any dangerous or poisonous substances.

Town/city, date

Signature and company stamp

ABB Measurement & Analytics

For your local ABB contact, visit:
www.abb.com/contacts

For more product information, visit:
www.abb.com/flow

We reserve the right to make technical changes or modify the contents of this document without prior notice. With regard to purchase orders, the agreed particulars shall prevail. ABB does not accept any responsibility whatsoever for potential errors or possible lack of information in this document.

We reserve all rights in this document and in the subject matter and illustrations contained therein. Any reproduction, disclosure to third parties or utilization of its contents – in whole or in parts – is forbidden without prior written consent of ABB.