

SensyMaster FMT430, FMT450

Thermal Mass Flowmeter



Modbus protocol
Valid as of software version
01.01.03

Measurement made easy

—
SensyMaster FMT430
SensyMaster FMT450

Introduction

The SensyMaster FMT430 is a top-quality cost-effective solution for the precise and direct dynamic mass flow measurement of gases at low and medium operating pressure levels, which fulfills the requirements of any industrial application.

In addition, the FMT450 offers the highest level of accuracy and extended functionality for demanding industrial applications.

Additional Information

Additional documentation on SensyMaster FMT430, FMT450 is available for download free of charge at www.abb.com/flow.

Alternatively simply scan this code:



Table of contents

1	Safety	3
	General information and instructions.....	3
	Cyber security disclaimer	3
	Software downloads.....	3
	Further documents	4
	Manufacturer's address.....	4
	Service address.....	4
2	Specification	4
	Modbus® communication.....	4
	Modbus response time	5
	Cable specification.....	5
3	Parameterization	6
	Parameterization via the Modbus interface.....	6
	Factory setting for the Modbus slave ID (address).....	6
	Changing an unknown Modbus slave ID.....	6
4	Interface description	7
	Register tables (overview).....	7
	Supported Modbus function codes.....	8
	Overview.....	8
	Modbus function codes.....	9
	0x02 – Read Discrete Inputs	9
	0x03 – Read Holding Registers.....	9
	0x04 – Read Input Registers.....	10
	0x06 – Write Single Register.....	10
	0x08 – Diagnostics	11
	0x10 – Write Multiple Registers.....	11
	0x11 – Report Slave ID.....	12
	Modbus error handling (exception codes).....	13
	Modbus data types	14
	Available units.....	15
	Available gas types.....	16
	Available process variables	17
	Application of the Health Indication Registers (Condensed Status Registers))	
	18
	Using the scan register.....	18
	Configuration register	18
	Scan Register	18
	Restrictions	18
	Design of the scan register (example).....	19
5	Parameter descriptions	20
	Parameter range – Device Info	20
	Parameter range – Device Setup.....	26
	Parameter range – Display.....	34
	Parameter range – Input/Output.....	36
	Parameter range – Process Alarm.....	42
	Parameter range – Communication.....	43
	Parameter range – Diagnostics.....	44
	Parameter range – Totalizer	49
	Parameter range – other functionalities.....	51
6	Diagnosis / error messages	52
	Error messages.....	52

1 Safety

General information and instructions

These instructions are an important part of the product and must be retained for future reference.

Installation, commissioning, and maintenance of the product may only be performed by trained specialist personnel who have been authorized by the plant operator accordingly. The specialist personnel must have read and understood the manual and must comply with its instructions.

For additional information or if specific problems occur that are not discussed in these instructions, contact the manufacturer.

The content of these instructions is neither part of nor an amendment to any previous or existing agreement, promise or legal relationship.

Modifications and repairs to the product may only be performed if expressly permitted by these instructions.

Information and symbols on the product must be observed.

These may not be removed and must be fully legible at all times.

The operating company must strictly observe the applicable national regulations relating to the installation, function testing, repair and maintenance of electrical products.

The following interface description is a supplement to the operating instruction of the SensyMaster FMT430/FMT450. The safety instructions it includes are valid and must be observed.

These instructions offer additional information about the supported Modbus functionalities and provide information about the configuration.

This description applies to the entire SensyMaster series FMT430/FMT450.

Cyber security disclaimer

This product is designed to be connected to and to communicate information and data via a network interface.

It is operator's sole responsibility to provide and continuously ensure a secure connection between the product and your network or any other network (as the case may be).

Operator shall establish and maintain any appropriate measures (such as but not limited to the installation of firewalls, application of authentication measures, encryption of data, installation of anti-virus programs, etc.) to protect the product, the network, its system and the interface against any kind of security breaches, unauthorized access, interference, intrusion, leakage and/or theft of data or information.

ABB and its affiliates are not liable for damages and/or losses related to such security breaches, any unauthorized access, interference, intrusion, leakage and/or theft of data or information.

On www.abb.com/cybersecurity under 'Additional resources', 'Alerts and notifications' you will find notifications about newly discovered software vulnerabilities. It is recommended that you visit this website regularly and activate 'Subscribe to email alerts' to receive email notifications about 'ABB cyber security alerts and notifications'.

Software downloads

By visiting the web page indicated below, you will find options to download the latest software. It is recommended that you visit this web page regularly:

[ABB-Library – SensyMaster FMT400 – Software Downloads](#)



... 1 Safety

Further documents

Note

All documentation, declarations of conformity, and certificates are available in ABB's download area.

www.abb.com/flow

Manufacturer's address

ABB AG

Measurement & Analytics

Schillerstr. 72
32425 Minden
Germany

Tel: +49 571 830-0

Fax: +49 571 830-1806

Service address

Customer service center

Tel: +49 180 5 222 580

Email: automation.service@de.abb.com

2 Specification

Modbus® communication

Note

The Modbus® protocol is an unsecured protocol (in terms of IT and cyber security), as such the intended application should be assessed to ensure that this protocol is suitable before implementation.

Modbus is an open standard owned and administrated by an independent group of device manufacturers styled the Modbus Organization (www.modbus.org/).

Using the Modbus protocol allows devices made by different manufacturers to exchange information via the same communication bus, without the need for any special interface devices to be used.

Modbus protocol

Terminals	V1 / V2
Configuration	Via the Modbus interface or via the local operating interface in connection with a corresponding Device Type Manager (DTM)
Transmission	Modbus RTU - RS485 serial connection
Baud rate	2400, 4800, 9600, 19200, 38400, 56000, 57600, 115200 baud Factory setting: 9600 baud
Parity	None, even, odd Factory setting: odd
Stop bit	One, two Factory setting: One
IEEE format	Little endian, big endian Factory setting: Little endian
Typical response time	< 100 ms
Response delay time	0 to 200 ms Factory setting: 10 ms

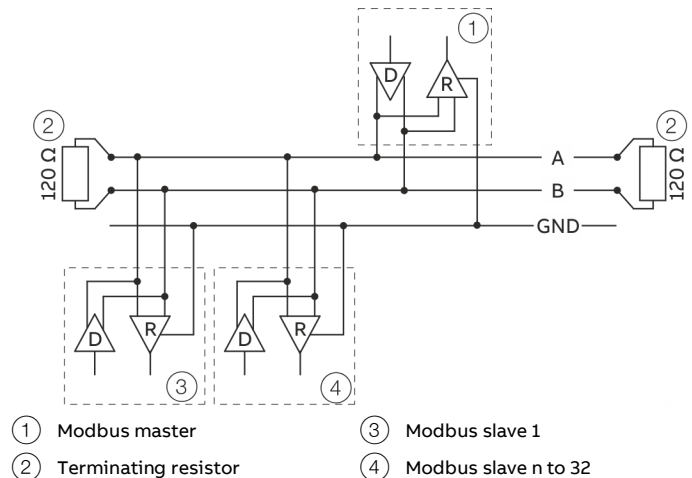

Figure 1: Communication via Modbus protocol

Modbus response time

The typical response time of the device is normally less than 100 ms (minimum response time). The response time is calculated from the end of the request telegram from the master to the beginning of the response telegram from the slave.

The response time can be increased via the parameter 'Response Delay'.

Refer to **Parameter range – Communication** on page 43.

The length of the response telegram is dependent upon the number of bytes read and the baud rate configured.

Cable specification

The maximum permissible length is dependent on the baud rate, the cable (diameter, capacity and surge impedance), the number of loads in the device chain, and the network configuration (2-core or 4-core).

- At a baud rate of 9600 and with a conductor cross-section of at least 0.14 mm² (AWG 26), the maximum length is 1000 m (3280 ft).
- When using a 4-core cable as a 2-wire wiring system, the maximum length must be halved.
- The spur lines must be short, a maximum of 20 m (66 ft).
- When using a distributor with 'n' connections, each branch must have a maximum length of 40 m (131 ft) divided by 'n.'

The maximum cable length depends on the type of cable used. The following standard values apply:

- Up to 6 m (20 ft):
cable with standard shielding or twisted-pair cable.
- Up to 300 m (984 ft):
double twisted-pair cable with overall foil shielding and integrated earth cable.
- Up to 1200 m (3937 ft):
double twisted-pair cable with individual foil shielding and integrated earth cables. Example: Belden 9729 or equivalent cable.

A category 5 cable can be used for Modbus RS485 up to a maximum length of 600 m (1968 ft). For the symmetrical pairs in RS485 systems, a surge impedance of more than 100 Ω is preferred, especially at a baud rate of 19200 and above.

3 Parameterization

Parameterization via the Modbus interface

Note **Parameter descriptions** on page 20 when parameterizing via the Modbus interface.

Factory setting for the Modbus slave ID (address)

The Modbus Slave ID of the device is preset at the factory. The Modbus Slave ID corresponds to the last two digits of the serial number of the device on the name plate.

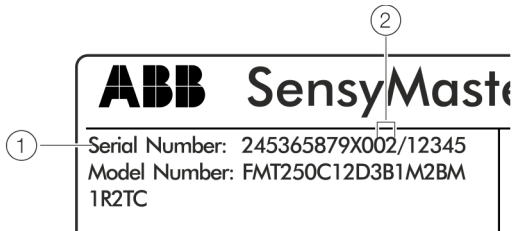

- ① Serial number ② Modbus slave ID when delivered

Figure 2: Modbus-address on the name plate (example)

Changing an unknown Modbus slave ID

The Modbus Slave ID (address) of the device must be known for Modbus communication.

Upon delivery, the Modbus Slave ID corresponds to the last two digits of the serial number of the device (see Figure 2, item ②).

If the Modbus address is not known, the Modbus Slave ID can be reset via a Modbus broadcast message. To do this, the following three Modbus registers must be sent to the bus together with the function code 16 (0x10) 'Write Multiple Registers.'

To set the Modbus Slave ID the Sensor ID of the device from the calibration certificate will be needed.

ABB

Kalibrierzertifikat

für Applikation Nr. 1

Serial Nummer: 245365879X002 / 12345 Zertifikatsnummer: 245365879X002_111017
Sensor ID: 119101001 TAG-Nummer: ABC-123

Kalibrierneuenstand

ABB

Calibration Certificate

for Application No. 1

Serial No: 245365879X002 / 12345 Certificate-Number: 245365879X002_111017
Sensor ID: 119101001 TAG-Number: ABC-123

Object of Calibration

Figure 3: Sensor ID on the calibration certificate

Address / data type [register length]	Description
65521 TUSIGN32 [2]	manufacturerDeviceID The manufacturer code (ABB = 0x1A) and the device code (FMT = 0x27) must be written to register 65522.
65523 TUSIGN32 [2]	sensorSerialID The Sensor ID of the device (on the calibration certificate). The information must first be written in the high-byte (65524) of the register.
65525 TUSIGN32 [2]	slaveID The new Modbus Slave ID must be written in the high byte (65526) of the register.

The three Modbus registers must now be sent from the Modbus master to the broadcast address '0.' All of the devices connected to the bus receive the message, but only the device addressed via the manufacturer code and the Sensor ID sets the Modbus Slave ID to the new required value.

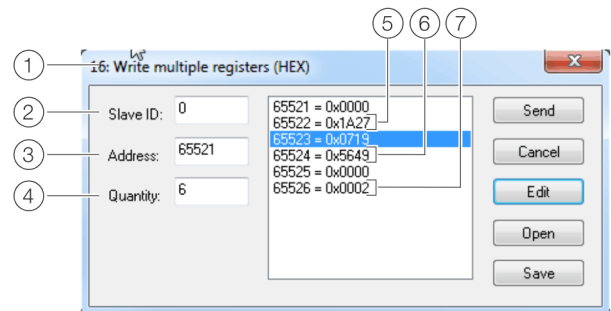

- ① Functional code 16 ⑤ Manufacturer and device codes
② Broadcast address "0" ⑥ Sensor ID
③ Register start address ⑦ New Modbus Slave ID
④ Number of registers

Figure 4: Write Multiple Registers (example)

4 Interface description

NOTICE

All Modbus addresses in this chapter are indicated in the format "PLC Base 1".

Register tables (overview)

Table ID [hex]	Table name	Table type	Data type	Start index	End index
Input coils					
0xD	Diagnostic and error messages	Coil	TUSIGN8	1	1998
Register					
0x0	Dynamic 8-bit integer values	Single	TUSIGN8	1	124
0x1	Action objects	Single	ACTION	9001	9999
0x2	32-bit float values (read only)	Single	TFLOAT	2201	2499
0x3	16-bit integer values (read only)	Single	TUSIGN16	2101	2199
0x4	32-bit float values, basis parameter	Single	TFLOAT	5001	5999
0x5	32-bit integer values, basis parameter	Single	TUSIGN32	3301	3399
0x6	8-bit integer values, basis parameter	Single	TUSIGN8	4001	4999
0x7	Scan Register 1 configuration	Single	TUSIGN16	3101	3150
0x8	Read Scan Register 1	Single	TUSIGN16	1101	1200
0x9	Scan Register 2 configuration	Single	TUSIGN16	3201	3250
0xA	Read Scan Register 2	Single	TUSIGN16	1201	1300
0xB	Application 1 to 8: floating point parameter	Single	TFLOAT	7001	8999
0xC	Character strings (read only)	String	TUSIGN8	2501	2999
0xE	Editable character strings	String	TCHAR	3401	4000
0xF	Dynamic 64-bit double values, mainly counter readings	Single	TDOUBLE	401	525
0x10	Set Modbus address (slave ID) with device code and sensor ID. Refer to Changing an unknown Modbus slave ID on page 6.	Single	TUSIGN32	65521	65526
0x11	Dynamic 32-bit float values, mainly process values	Single	TFLOAT	201	324
0x12	8-bit integer values (read only)	Single	TUSIGN8	2001	2099
0x13	Application 1 to 8: byte parameter	Single	TUSIGN8	6001	6999

The device error messages are transmitted via the Modbus® interface by means of the 'Input Coils.' For more detailed information, see **Diagnosis / error messages** on page 52.

... 4 Interface description

Supported Modbus function codes

Overview

The function codes listed below are supported by SensyMaster FMT430, FMT450.

Function code	Description	Applicable to register tables
0x02	Read Discrete Inputs	Alarm status Discrete Inputs Alarm history status Discrete Inputs
0x03	Read Holding Registers	Read-write Byte parameters Read-write Byte string parameters Read-write Float parameters Action parameters
0x04	Read Input Registers	Read-only Byte parameters Read-only Short parameters Read-only Integer parameters Read-only Float parameters Read-only Double parameters Alarm history counters Read-only Byte string parameters
0x06	Write Single Register	Read-write Byte parameters Read-write Byte string parameters Action parameters
0x08	Diagnostics	NA
0x10	Write Multiple Registers	Read-write Byte parameters Read-write Byte string parameters Read-write Float parameters Action parameters
0x11	Report Slave ID	NA

Modbus function codes

In this chapter, all Modbus function codes supported by SensyMaster FMT430, FMT450 are described.

0x02 – Read Discrete Inputs

The 'Read Discrete Inputs' function code is used to read off register 'Discrete Inputs (Coil)' of the device.

The query telegram is designed as follows:

Byte	Description
1	Slave device code
2	Read Discrete Inputs Function Code, 0x02.
3, 4	Discrete input address. 16-bit value indicating the address of the first discrete input to be read.
5, 6	Number of discrete inputs. 16-bit value indicating the number of discrete inputs to be read.
7, 8	Check sum (CRC) of the Modbus telegram

The reply telegram to a successfully processed query is designed as follows:

Byte	Description
1	Slave device code
2	Read Discrete Inputs Function Code, 0x02.
3	Anzahl (n) der Datenbytes im Antwort-Telegramm
4 to (4+n)-1	Discrete input data. Up to 2000 discrete inputs can be read in one request, if available.
(4+n),	Check sum (CRC) of the Modbus telegram
(4+n)+1	

0x03 – Read Holding Registers

The 'Read Holding registers' function code is used to read off the 'Read Holding Registers' of the device.

The query telegram is designed as follows:

Byte	Description
1	Slave device code
2	Read Holding Registers Function Code, 0x03.
3, 4	Holding register address. 16-bit address indicating the address of the first holding register to read.
5, 6	Holding register count. 16-bit value indicating the number of holding registers to read.
7, 8	Check sum (CRC) of the Modbus telegram

The reply telegram to a successfully processed query is designed as follows:

Byte	Description
1	Slave device code
2	Read Holding Registers Function Code, 0x03.
3	Holding register count ('n'). 8-bit value indicating the count of holding registers returned in the message.
4 to (4+n)-1	Holding register data.
(4+n),	Check sum (CRC) of the Modbus telegram
(4+n)+1	

... 4 Interface description

... Modbus function codes

0x04 – Read Input Registers

The 'Read Input Registers' function code is used to read off the 'Input Register' of the device.

The query telegram is designed as follows:

Byte	Description
1	Slave device code
2	Read Input Registers Function Code, 0x04.
3, 4	Input register address. 16-bit value indicating the address of the first input register to read.
5, 6	Input register count. 16-bit value indicating the number of input registers to read.
7, 8	Check sum (CRC) of the Modbus telegram

The reply telegram to a successfully processed query is designed as follows:

Byte	Description
1	Slave device code
2	Read Input Registers Function Code, 0x04.
3	Number (n) of data bytes in the reply telegram
4 to (4+n)-1	Input register data.
(4+n), (4+n)+1	Check sum (CRC) of the Modbus telegram

0x06 – Write Single Register

The 'Write Single Register' function code is used to write a value in one of the 'Holding Register' of the device.

The query telegram is designed as follows:

Byte	Description
1	Slave device code
2	Write Single Register Function Code, 0x06.
3, 4	16-bit holding register address.
5, 6	Holding register value. 16-bit value indicating the value to write.
7, 8	Check sum (CRC) of the Modbus telegram

The reply telegram to a successfully processed query is designed as follows:

Byte	Description
1	Slave device code
2	Write Single Register Function Code, 0x06.
3, 4	Holding register address. 16-bit value indicating the address of the holding register that was written.
5, 6	Holding register value. 16-bit value indicating the value that was written to the holding register.
7, 8	Check sum (CRC) of the Modbus telegram

0x08 – Diagnostics

Only the subfunction 'Return Query Data (0x00, 0x00)' is supported.

If the device receives a query telegram, the telegram is sent back to the Master without changes.

The query and reply telegrams are designed as follows:

Byte	Description
1	Slave device code
2	Diagnostics Function Code, 0x08.
3, 4	Sub-query identifier, 0x00, 0x00.
5 to (5+n)-1	Diagnostics query data. (Of length 'n').
(5+n)	Check sum (CRC) of the Modbus telegram
(5+n)+1	

0x10 – Write Multiple Registers

The 'Write Multiple Register' function code is used to write a value in the 'Holding Register' of the device.

The query telegram is designed as follows:

Byte	Description
1	Slave device code
2	Write Multiple Registers Function Code, 0x10.
3, 4	Holding register address. 16-bit value indicating the address of the first holding register to write.
5, 6	Holding register count. 16-bit value indicating the number of holding registers to write
7	Byte count ('n'), number of data bytes in the request.
8 to (8+n)-1	Holding register message data. The data to write to the holding registers.
(8+n)	Check sum (CRC) of the Modbus telegram
(8+n)+1	

The reply telegram to a successfully processed query is designed as follows:

Byte	Description
1	Slave device code
2	Write Multiple Registers Function Code, 0x10.
3, 4	Holding register address. 16-bit value indicating the address of the first holding register.
5, 6	Holding register count. 16-bit value indicating the number of holding registers written.
7, 8	Check sum (CRC) of the Modbus telegram

... 4 Interface description

... Modbus function codes

0x11 – Report Slave ID

The 'Report Slave ID' commando is used to uniquely identify the slave device.

The query telegram is designed as follows:

Byte	Description
1	Slave device code
2	Report Slave ID Function Code, 0x11.
3, 4	Check sum (CRC) of the Modbus telegram

The reply telegram to a successfully processed query is designed as follows:

Byte	Description
1	Slave device code
2	Report Slave ID Function Code, 0x11
3	Number of data bytes
4	Manufacturer identification for ABB 0x1A
5	Device code for SensyMaster devices, 0x27
6	Software version, 0x30
7	Hardware version, 0x30
8	Not used, 0x30
9 to 11	Reserved for future use, 0x30,0x30,0x30
12 to 33	Device name (Hex) "41 42 42 20 46 4d 54 34 78 78 20 53 65 6e 73 79 4d 61 73 74 65 72" (ASCII) 'ABB FMT4xx SensyMaster'
34 to 35	Check sum (CRC) of the Modbus telegram

Modbus error handling (exception codes)

If the recipient of the message determines an error, it sends an appropriate error message back to the Master. Here the function code from query telegram 0x80 is added. An appropriate error code is sent as data. The following error codes are supported:

Error code	Name	Description
0x01	ILLEGAL_FUNCTION	Use of an unsupported function code or the device currently cannot process the query.
0x02	ILLEGAL_DATA_ADDRESS	Invalid register address is used or an attempt has been made to write to a write-protected register address.
0x03	ILLEGAL_DATA_VALUE	Use of unauthorized data values, for example an incorrect number of registers.
0x04	SLAVE_DEVICE_FAILURE	The device currently cannot process the query. Repeat the query later.

The reply telegram with error message is designed as follows:

Byte	Description
1	Slave device code
2	Function code + 0x80
3	Error code (exception code)
4,5	Check sum (CRC) of the Modbus telegram

... 4 Interface description

Modbus data types

ABB data type	Data type	Register count	Description
ACTION	unsigned char	One register	The data type 'ACTION' is used to trigger device functions. Parameters with the data type 'ACTION' have no internal memory requirements. Writing any value into the parameters triggers the corresponding device function.
TUSIGN8	unsigned char	One register	16-bit register, but only the first 8-bits are used - unsigned char.
TUSIGN16	unsigned short	One register	16-bit unsigned integer
TINT16	signed short	One register	16-bit signed integer
TUSIGN32	unsigned long	Two consecutive registers	32-bit unsigned integer
TINT32	signed long	Two consecutive registers	32-bit signed integer
TCHAR	unsigned char	One register. The total length of the register depends on the object length.	16-bit register, but only the first 8-bits are used - unsigned char. The register content is interpreted as an ASCII-value.
TFLOAT	float	Two consecutive registers	32-bit IEEE floating point. The device parameter 'IEEE Number Format' determines the order in which the data words of the data types 'float' and 'double' are interpreted. See also Parameter range – Communication on page 43.
TDOUBLE	double	Four consecutive registers	64-bit IEEE double-precision floating point. The device parameter 'IEEE Number Format' determines the order in which the data words of the data types 'float' and 'double' are interpreted. See also Parameter range – Communication on page 43. If the parameter is set to '1' (IEEE format deactivated), the data words of the data types 'float' and 'double' are sent in the standard Modbus format 'big endian'. Example: The value '5.525' is returned in hex as '40, 16, 19, 99, 99, 99, 99, 9A'. If the parameter is set to '0' (IEEE format activated), the data words of the data types 'float' and 'double' are sent in the format 'little endian' with the lowest value word first. Example: The value '5.525' is returned in hex as '99, 9A, 99, 99, 19, 99, 40, 16'.

Available units

For certain parameters it is possible to choose among the following units.

Note

The 'Code' column indicates the value to which the corresponding parameter must be set, e.g. using the communications interface.

Table 1: Units for the standard volume flow

Selection	Code	Description
m ³ /s	13	Cubic meters per second
m ³ /min	14	Cubic meters per minute
m ³ /h	15	Cubic meters per hour
m ³ /d	16	Cubic meters per day
ft ³ /s	29	Cubic feet per second
ft ³ /min	30	Cubic feet per minute
ft ³ /h	31	Cubic feet per hour
ft ³ /d	32	Cubic feet per day
l/s	48	Liters per second
l/min	49	Liters per minute
l/h	50	Liters per hour
l/d	51	Liters per day
SCFS	144	Standard cubic feet per second
SCFM	145	Standard cubic feet per minute
SCFH	146	Standard cubic feet per hour
SCFD	147	Standard cubic feet per day
MSCFM	149	One thousand standard cubic feet per minute
MSCFH	150	One thousand standard cubic feet per hour
MSCFD	151	One thousand standard cubic feet per day
MMSCFH	154	One million standard cubic feet per hour
MMSCFD	155	One million standard cubic feet per day
xx/yy	254	User-defined unit

Table 2: Units for the mass flow

Selection	Code	Description
g/s	1	Grams per second
g/min	2	Grams per minute
g/h	3	Grams per hour
kg/s	5	Kilograms per second
kg/min	6	Kilograms per minute
kg/h	7	Kilograms per hour
kg/d	8	Kilograms per day
lb/s	9	Pounds (avdp) per second
lb/min	10	Pounds (avdp) per minute
lb/h	11	Pounds (avdp) per hour
lb/d	12	Pounds (avdp) per day
t/s	29	Metric tons per second
t/min	30	Metric tons per minute
t/h	31	Metric tons per hour
t/d	32	Metric tons per day
xx/yy	254	User-definable unit

Table 3: Standard density units

Selection	Code	Description
g/cm ³	1	Grams per cubic centimeter
g/m ³	3	Grams per cubic meter
kg/m ³	4	Kilograms per cubic meter
g/l	10	Grams per liter
kg/l	11	Kilograms per liter
lb/ft ³	13	Pounds (avdp) per cubic foot
xx/yy	254	User-definable unit

Table 4: Standard conditions

Code	Description
1	Temperature = 0 °C, pressure = 1.01325 bar
2	Temperature = 20 °C, pressure = 1.01325 bar
3	Temperature = 60°F, pressure = 1.01325 bar
4	Temperature = 70°F, pressure = 1.01325 bar
5	Temperature = 15°C, pressure = 1.01325 bar
6	Temperature = 20°C, pressure = 1.00000 bar
7	Temperature = 25°C, pressure = 1.00000 bar
8	Temperature = 25°C, pressure = 1.01325 bar
9	Temperature = 15°C, pressure = 1.00000 bar
254	User-defined standard conditions

Table 5: Temperature units

Selection	Code	Description
K	1	Kelvin
°C	2	Celsius
°F	3	Fahrenheit

Table 6: Units of length

Selection	Code	Description
mm	4	Millimeters
inch	13	in.

Table 7: Units for the mass counter

Selection	Code	Description
kg	2	Kilograms
g	3	Grams
t	5	Tons (metric)
lb	8	Pounds (advp)
xx	254	User-definable unit

... 4 Interface description

... Available units

Table 8: Units for the standard volume totalizer

Selection	Code	Description
m ³	4	Cubic meters
ft ³	7	Cubic feet
SCF	32	Standard cubic feet
MSCF	33	One thousand standard cubic feet
MMSCF	34	One million standard cubic feet
l	13	Liters
xx	254	User-definable unit

Table 9: Pressure units

Selection	Code	Description
Pa	1	Pascals
kPa	4	Kilopascals
Bar	8	Bar
mBar	9	Millibar
inH ₂ O@4C	51	Inches water column at 4 °C
mmH ₂ O@4C	54	mm water column at 4 °C
atm	64	Atmospheric gauge pressure
psi	65	Pounds per square inch
kp/cm ²	69	Kilogram-force per cm ²

Available gas types

For certain parameters it is possible to choose among the following gas types.

Note

The 'Code' column indicates the value to which the corresponding parameter must be set, e.g. using the communications interface.

Table: Gas types for the ApplicationSelector

Formula	Code [hex]	Description
-	0x00	No selection
N ₂ O ₂ Ar	0x01	Air* (only for gas type 1 of one application)
CH ₄	0x90	Methane
N ₂	0xB5	Nitrogen
H ₂	0x84	Hydrogen
CO ₂	0x48	Carbon dioxide
O ₂	0xBB	Oxygen
NH ₃	0x27	Ammonia
He	0x78	Helium
Ar	0x2A	Argon
C ₃ H ₈	0xCD	Propane
C ₂ H ₆	0x6C	Ethane
C ₄ H ₁₀	0x45	Butane
C ₅ H ₁₂	0xC1	Pentane
C ₆ H ₁₄	0x7B	Hexane
O ₃	0xBE	Ozone
C ₂ H ₄	0x72	Ethene
C ₂ H ₅ OH	0x6F	Ethanol

Table: Gas types for the ApplicationSelector

Formula	Code [hex]	Description
C ₃ H ₆	0xD0	Propene/Propylene
CO	0x4B	Carbon monoxide
H ₂ S	0x87	Hydrogen sulfide
C ₂ H ₂	0x1E	Acetylene
C ₃ H ₆ O	0x24	Acetone
CH ₂ CO	0x51	Ketene
C ₄ H ₄ O ₂	0x66	Diketene
CH ₃ OH	0x93	Methanol
Ne	0xAF	Neon
NO	0xB2	Nitrogen monoxide
C ₃ H ₄	0xCA	Propadiene
H ₂ O	0xE8	Water vapor
C ₄ H ₆	0x3C	1.2 Butadiene
C ₄ H ₆	0x3F	1.3 Butadiene
C ₄ H ₈	0x42	1 Butene
CH ₂ O	0x75	Formaldehyde
H ₂ O	0xE8	Water vapor

* Gas type available in ApplicationSelector (preconfigured applications) and for three configurable applications.

** Gas type available only for preconfigured applications.

Available process variables

The process variables available in the software are listed in the table.

Note

- Some of the process variables can be assigned to the digital outputs DO1 (terminals 41 / 42) and DO2 (terminals 51 / 52), configured as frequency [f] or pulse output [pulse].
(Code) indicates to which value the parameters 'Output Value Freq.' and 'Output Value Pulse' must be set. See also **Parameter range – Input/Output** on page 36.
- The 'Modbus address' column indicates the Modbus register address, data type and the register length for the corresponding process variable.

Process variable	Short form	Description	DO1 / 2	DO1 / 2	Modbus address	
			[f] (Code)	[pulse] (Code)	TFLOAT [2]	TDOUBLE [4]
Mass Flow [unit]	Qm	Mass flow in the selected mass flow unit	–	X (1)	201	–
Mass Flow [%]	Qm	Mass flow in percent	X (1)	–	209	–
Volume Flow @ [unit]	Qv@	Standard volume flow in the selected volume unit	–	X (2)	205	–
Volume Flow @ [%]	Qv@	Standard volume flow in percent	X (2)	–	213	–
Temperature [unit]	Tm	Temperature in the selected standard volume unit	–	–	203	–
Temperature [%]	Tm	Temperature in percent	X (3)	–	211	–
Density @	p@	Standard density in the selected density unit	–	–	207	–
Totalizer Qm	Σm	Mass flow counter reading in the selected unit	–	–	215	409
Totalizer Qv @	Σv@	Standard volume flow counter reading in the selected unit	–	–	217	413
Current Batch Total*	CBT	Current fill quantity	–	–	219	405
Current Batch Counts*	CBC	Number of fill operations	–	–	3315	–
					TUSIGN32 [2]	

* Process variable is only available if the DensiMass function is activated.

X = process variable available, — = process variable not available.

... 4 Interface description

Application of the Health Indication Registers (Condensed Status Registers))

The SensyMaster FMT430, FMT450 has three 'Health indication registers' (Condensed Status Registers). The 'Health indication register 2104, 2105 and 2106 consist of 2 bytes, each containing 8 bits. Each bit represents an error.

The registers are structured as follows:

2104		2105		2106																											
Byte 0	Byte 1	Byte 2	Byte 3	Byte 4	Byte 5																										
0	1	2	3	4	5	6	7	0	1	2	3	4	5	6	7	0	1	2	3	4	5	6	7	0	1	2	3	4	5	6	7
■	■	■	■	■	■	■	■	■	■	■	■	■	■	■	■	■	■	■	■	■	■	■	■	■	■	■	■	■	■	■	■

■ = true (1) □ = false (0)

Figure 5: Health indication register (Example)

The bit position is assigned to the errors in accordance with column 'Byte / Bit pos.' of the table in **Error messages** on page 52.

The following assignment applies to the example in Figure 5:

Byte / Bit	Fault message
Byte 0 / Bit 3	Flowrate to zero
Byte 0 / Bit 5	All totalizer stopp.
Byte 4 / Bit 5	Medium temperat exceeds limits.

Using the scan register

The SensyMaster FMT430, FMT450 has two 'Scan Register' via which groups of parameters can be requested.

As a result, the parameters do not need to be requested individually and the bus load on the Modbus is reduced.

A scan register consists of a configuration register and the actual scan register.

Configuration register

The Modbus addresses of the parameters are entered in the configuration register. These addresses are to be requested as a group when the scan register is read. The configuration is stored in the transmitter and must only be rewritten in the event of changes. A maximum of 32 Modbus addresses may be stored.

Scan Register

When read out, the Scan Register returns the values of the parameters that were entered in the configuration register. The scan register has a length of 32 holding registers that must be considered when entering addresses in the configuration register.

For example, a maximum of 32 addresses with a register length of [1] can be requested via the scan register.

Note

If the total register length of the addresses entered in the configuration register exceeds the register length of the scan register, the response will be shortened accordingly when read out.

Restrictions

When using the Scan Registers, observe the following points:

- The scan registers are read only. It is not possible to gain write access to the parameters entered in the configuration register.
- Action Registers cannot be addressed via the Scan Registers, as Action Registers require write access
- String Registers cannot be read out via the Scan Registers, as a String would overwrite the available register length of the Scan Register in most cases.

Design of the scan register (example)

Content of the configuration register (Config scan register)

Config scan register 1, register range address 3101 to 3132

Config scan register 2, register range address 3201 to 3232

Configuration register	Parameter address	Parameter descriptions
3101 / 3201	201	Mass flow in the selected mass flow unit (data type float, register length 2)
3102 / 3202	205	Volume flow in the selected volume unit (data type float, register length 2)
3103 / 3203	215	Mass flow counter reading in forward flow direction (data type float, register length 2)
3104 / 3204	217	Volume flow counter reading in forward flow direction (data type float, register length 2)
3105 / 3205	2104	Diagnosis State 0 (data type Usign 16, register length 1)
3106 / 3206	2105	Diagnosis State 1 (data type Usign 16, register length 1)
3107 / 3207	2106	Diagnosis State 2 (data type Usign 16, register length 1)
3108 / 3208	4013	Mass flow unit Qm (data type Usign 8, register length 1)
... / ...	0	Non-configured register spaces must be filled with FFF.
3132 / 3232	0	

Response following the scan register request

In this example, 12 registers are used in the scan register.

Scan register 1, register range address 1100 to 1199

Scan register 2, register range address 1200 to 1299

Configuration register	Register content
1101 / 1201	Mass flow (data type float, register length 2)
1102 / 1202	
1103 / 1203	Volume flow (data type float, register length 2)
1104 / 1204	
1105 / 1205	Mass flow counter reading in forward flow direction (data type float, register length 2)
1106 / 1206	
1107 / 1207	Volume flow counter reading in forward flow direction (data type float, register length 2)
1108 / 1208	
1109 / 1209	Diagnosis state 0 (data type Usign 16, register length 1)
1110 / 1210	Diagnosis state 1 (data type Usign 16, register length 1)
1111 / 1211	Diagnosis state 2 (data type Usign 16, register length 1)
1112 / 1212	Mass flow unit Qm (data type Usign 8, register length 1)
... / ...	Non-configured register spaces remain unpopulated.
1132 / 1232	

5 Parameter descriptions

Parameter range – Device Info

The parameterization of the device can be read out via the Modbus addresses listed here.

All Modbus addresses specified here are read only.

Modbus register address	Parameter name	Data type [register length] / value range	Description
... / Sensor			
3421	Sensor Location Tag	TCHAR [20]	Sensor measuring point tagging
3401	Sensor Tag	TCHAR [20]	Tag number of the sensor
2013	Sensor Element Type	TUSIGN8 [1] 0: Unknown 1: Standard ceramics 2: Ceramics high temperature design 3: Standard stainless steel 4: Hygienic stainless steel 5: Other	Sensor element type
2233	Sensor Length	TFLOAT [1]	Installation length of the sensor
2012	Feature Series	TUSIGN8 [1] 50: FMT230 60: FMT250 90: FMT410 100: FMT430 110: FMT450	Sensor model. Specific functions such as the filling function are available depending on the selection
3301	Sensor ID	TUSIGN32 [2]	ID number of the sensor.
2501	Sensor Serial No.	TCHAR [20]	Serial number of the sensor.
3303	Sensor Run Hours	TUSIGN32 [2]	Operating hours of the sensor.
... / Sensor / Calibration			
2016	First Cal. Date	TUSIGN8 [3]	Date of first calibration of sensor (calibration of new device).
2022	Last Cal. Date	TUSIGN8 [3]	Date of last calibration of sensor.
2521	Cal. Cert. No.	TCHAR [20]	Identification (number) of the relevant calibration certificate.
2541	First Cal. Location	TCHAR [20]	Place of first calibration of the sensor.
2561	Last Cal. Location	TCHAR [20]	Place of last calibration of sensor.
... / Sensor / ...ApplicationSelector			
6081	Application	TUSIGN8 [4] 0: Air 1: Application 1 ... 7: Application 8	Display of the selected application (type of measuring medium)
6081	Dig.In 0 Application	TABENUM8 [1]	Display of the use of optional digital inputs for application switching. You can switch between four applications by wiring the digital inputs.
6082	Dig.In 1 Application		
6083	Dig.In 2 Application		
6084	Dig.In1+2Application		

Note

The numbers in brackets (1 to 8) in the Modbus register addresses correspond to the associated application 1 to 8.

Modbus register address (application)	Parameter name	Data type [register length] / value range	Description
... / Sensor / ...Application 1 ... 8			
3521 (1), 3553 (2), 3585 (3), 3617 (4), 3649 (5), 3681 (6), 3713 (7), 3745 (8)	Description	TCHAR [32]	Name of the application 1 to 8.
... / Sensor / ...Application 1 ... 8 / ...A1...Flow meas. – ...A8...Flow meas.			
2201 (1), 2203 (2), 2205 (3), 2207(4), 2209 (5), 2211 (6), 2213 (7), 2215 (8)	Qm Max. DN	TFLOAT [2]	Maximum mass flow for the selected nominal diameter.
7177 (1), 7223 (2), 7269 (3), 7315 (4), 7361 (5), 7407 (6), 7453 (7), 7499 (8)	Qm Max	TFLOAT [2]	Set measuring range, maximum mass flow
7179 (1), 7225 (2), 7271 (3), 7317 (4), 7363 (5), 7409 (6), 7455 (7), 7501 (8)	Qm Min	TFLOAT [2]	Set measuring range, minimum mass flow
2217 (1), 2219 (2), 2221 (3), 2223 (4), 2225 (5), 2227 (6), 2229 (7), 2231 (8)	Qv@ Max. DN	TFLOAT [2]	Maximum volume flow for the selected nominal diameter at Qm Max. DN.
7189 (1), 7235 (2), 7281 (3), 7327 (4), 7373 (5), 7419 (6), 7465 (7), 7511 (8)	Qv@ Max	TFLOAT [2]	Set measuring range, maximum standard volume flow
7191 (1), 7237 (2), 7283 (3), 7329 (4), 7375 (5), 7421 (6), 7467 (7), 7513 (8)	Qv@ Min	TFLOAT [2]	Set measuring range, minimum standard volume flow
7175 (1), 7221 (2), 7267 (3), 7313 (4), 7359 (5), 7405 (6), 7451 (7), 7497 (8)	Damping Q	TFLOAT [2]	Damping for flow measurement.
7181 (1), 7227 (2), 7273 (3), 7319 (4), 7365 (5), 7411 (6), 7457 (7), 7503 (8)	Low Flow Cut Off	TFLOAT [2]	Threshold to activate the low flow cut-off.
7183 (1), 7229 (2), 7275 (3), 7321 (4), 7367 (5), 7413 (6), 7459 (7), 7505 (8)	LowFlow Hysteresis	TFLOAT [2]	Hysteresis for low flow cut-off.

... 5 Parameter descriptions

... Parameter range – Device Info

Modbus register address (application)	Parameter name	Data type [register length] / value range	Description
... / Sensor / ...Application 1 ... 8 / ...A1...Temp. meas. – ...A8...Temp. meas.			
7199 (1), 7245 (2), 7291 (3), 7337 (4), 7383 (5), 7429 (6), 7475 (7), 7521 (8)	Tm Max	TFLOAT [2]	Set measuring range, maximum measuring medium temperature.
7201 (1), 7247 (2), 7293 (3), 7339 (4), 7385 (5), 7431 (6), 7477 (7), 7523 (8)	Tm Min	TFLOAT [2]	Set measuring range, minimum measuring medium temperature.
7197 (1), 7243 (2), 7289 (3), 7335 (4), 7381 (5), 7427 (6), 7473 (7), 7519 (8)	Damping Tm	TFLOAT [2]	Damping for temperature measurement.
... / Sensor / ...Application 1 ... 8 / ...A1...Pipe type – ...A8...Pipe type			
6085 (1), 6086 (2), 6087 (3), 6088 (4), 6089 (5), 6090 (6), 6091 (7), 6092 (8)	Shape and probe pos.	TUSIGN8 [3]	Piping form and sensor position.
7165 (1), 7211 (2), 7257 (3), 7303 (4), 7349 (5), 7395 (6), 7441 (7), 7487 (8)	Inside diameter	TFLOAT [2]	Inside diameter of the piping.
7165 (1), 7211 (2), 7257 (3), 7303 (4), 7349 (5), 7395 (6), 7441 (7), 7487 (8)	Duct inner height	TFLOAT [2]	Inside height of the channel with rectangular cross-section.
7169 (1), 7215 (2), 7261 (3), 7307 (4), 7353 (5), 7399 (6), 7445 (7), 7491 (8)	Insertion depth	TFLOAT [2]	Insertion depth of the sensor with regard to the inside diameter or the inside height. This parameter is relevant only if the sensor position is not centered.
7167 (1), 7213 (2), 7259 (3), 7305 (4), 7351 (5), 7397 (6), 7443 (7), 7489 (8)	Duct inner width	TFLOAT [2]	Inside width of the channel with rectangular cross-section.

Modbus register address (application)	Parameter name	Data type [register length] / value range	Description
... / Sensor / ...Application 1 ... 8 / ...A1...Gas data – ...A8...Gas data			
7163 (1), 7209 (2), 7255 (3), 7301 (4), 7347 (5), 7393 (6), 7439 (7), 7485 (8)	Mean Operating Temp.	TFLOAT [2]	Average measuring medium temperature of the application.
7161 (1), 7207 (2), 7253 (3), 7299 (4), 7345 (5), 7391 (6), 7437 (7), 7483 (8)	Mean Operating Press	TFLOAT [2]	Average measuring medium pressure of the application.
6001 (1), 6011 (2), 6021 (3), 6031 (4), 6041 (5), 6051 (6), 6061 (7), 6071 (8)	Gas Type 1	TUSIGN8 [1] Refer to Available gas types on page 16.	Gas type and concentration for gas components 1 to 10 of a gas mix.
7001 (1), 7021 (2), 7041 (3), 7061 (4), 7081 (5), 7101 (6), 7121 (7), 7041 (8)	Concentr. Gas Type 1	TFLOAT[2] 10 to 100 %	
6002 (1), 6012 (2), 6022 (3), 6032 (4), 6042 (5), 6052 (6), 6062 (7), 6072 (8)	Gas Type 2	TUSIGN8 [1]	
7003 (1), 7023 (2), 7043 (3), 7063 (4), 7083 (5), 7103 (6), 7123 (7), 7043 (8)	Concentr. Gas Type 2	TFLOAT[2] 0 to 50 %, depending on residual quantity	
6003 (1), 6013 (2), 6023 (3), 6033 (4), 6043 (5), 6053 (6), 6063 (7), 6073 (8)	Gas Type 3	TUSIGN8 [1]	
7005 (1), 7025 (2), 7045 (3), 7065 (4), 7085 (5), 7105 (6), 7125 (7), 7045 (8)	Concentr. Gas Type 3	TFLOAT[2] 0 to 33.33 %, depending on residual quantity	
6004 (1), 6014 (2), 6024 (3), 6034 (4), 6044 (5), 6054 (6), 6064 (7), 6074 (8)	Gas Type 4	TUSIGN8 [1]	
7007 (1), 7027 (2), 7047 (3), 7067 (4), 7087 (5), 7107 (6), 7127 (7), 7047 (8)	Concentr. Gas Type 4	TFLOAT[2] 0 to 25 %, depending on residual quantity	
6005 (1), 6015 (2), 6025 (3), 6035 (4), 6045 (5), 6055 (6), 6065 (7), 6075 (8)	Gas Type 5	TUSIGN8 [1]	
7009 (1), 7029 (2), 7049 (3), 7069 (4), 7089 (5), 7109 (6), 7129 (7), 7049 (8)	Concentr. Gas Type 5	TFLOAT[2] 0 to 20 %, depending on residual quantity	

... 5 Parameter descriptions

... Parameter range – Device Info

Modbus register address (application)	Parameter name	Data type [register length] / value range	Description
6006 (1), 6016 (2), 6026 (3), 6036 (4), 6046 (5), 6056 (6), 6066 (7), 6076 (8)	Gas Type 6	TUSIGN8 [1]	Gas type and concentration for gas components 1 to 10 of a gas mix.
7011 (1), 7031 (2), 7051 (3), 7071 (4), 7091 (5), 7111 (6), 7131 (7), 7051 (8)	Concentr. Gas Type 6	TFLOAT[2] 0 to 16.67 %, depending on residual quantity	
6007 (1), 6017 (2), 6027 (3), 6037 (4), 6047 (5), 6057 (6), 6067 (7), 6077 (8)	Gas Type 7	TUSIGN8 [1]	
7013 (1), 7033 (2), 7053 (3), 7073 (4), 7093 (5), 7113 (6), 7133 (7), 7053 (8)	Concentr. Gas Type 7	TFLOAT[2] 0 to 14.29 %, depending on residual quantity	
6008 (1), 6018 (2), 6028 (3), 6038 (4), 6048 (5), 6058 (6), 6068 (7), 6078 (8)	Gas Type 8	TUSIGN8 [1]	
7015 (1), 7035 (2), 7055 (3), 7075 (4), 7095 (5), 7115 (6), 7135 (7), 7055 (8)	Concentr. Gas Type 8	TFLOAT[2] 0 to 12.5 %, depending on residual quantity	
6009 (1), 6019 (2), 6029 (3), 6039 (4), 6049 (5), 6059 (6), 6069 (7), 6079 (8)	Gas Type 9	TUSIGN8 [1]	
7017 (1), 7037 (2), 7057 (3), 7077 (4), 7097 (5), 7117 (6), 7137 (7), 7057 (8)	Concentr. Gas Type 9	TFLOAT[2] 0 to 11.11 %, depending on residual quantity	
6010 (1), 6010 (2), 6030 (3), 6040 (4), 6050 (5), 6060 (6), 6070 (7), 6080 (8)	Gas Type 10	TUSIGN8 [1]	
7019 (1), 7039 (2), 7059 (3), 7079 (4), 7099 (5), 7119 (6), 7139 (7), 7059 (8)	Concentr. Gas Type 10	TFLOAT[2] 0 to 10%, depending on residual quantity	
... / Sensor / ...Application 1 ... 8 / ...A2...Field Optim. – ...A8...Field Optim.			
7171 (1), 7217 (2), 7263 (3), 7309 (4), 7355 (5), 7401 (6), 7447 (7), 7493 (8)	Offset Qm	TFLOAT [2]	Offset correction of the flow rate measured value.
7173 (1), 7219 (2), 7265 (3), 7311 (4), 7357 (5), 7403 (6), 7449 (7), 7495 (8)	Corr.Factor Qm	TFLOAT [2]	Correction factor for the flow measured value.

Modbus register address	Parameter name	Data type [register length] / value range	Description
... / ...Transmitter			
2011	Transmitter Type	TUSIGN8 [1] 3: FMT4xx – remote mount design 4: FMT2xx 7: FMT4xx – Integral mount design	Display of the transmitter type.
3305	Transmitter ID	TUSIGN32 [2]	ID number of transmitter.
2581	Transm.Serial No.	TCHAR [20]	Order number of the transmitter.
3307	Transm. Run Hours	TUSIGN32 [2]	Operating hours of the transmitter (frontend board).
2110	Tx Restart Counter	TUSIGN16 [1]	Number of device restarts (switching the power supply off and on).
3309	Time since Restart	TUSIGN32 [2]	Device operating hours since the last restart.
2028	FillMass On/Off	TUSIGN8 [1] 0: Off 1: On	FillMass function present? 0 - Off: No FillMass function present. 1 - On: FillMass function present.
2029	VeriMass On/Off	TUSIGN8 [1] 0: Off 1: On	VeriMass function present? 0 - Off: No VeriMass function present. 1 - On: VeriMass function present.
2661	Manufacturer	TUSIGN8 [20]	Name of manufacturer.
2681	Street	TUSIGN8 [20]	Manufacturer's address (street)
2701	City	TUSIGN8 [20]	Manufacturer's address (city)
2721	Phone	TUSIGN8 [20]	Manufacturer's address (phone number)
... / ...Transmitter / ...Transmitter Version			
2001	FW Device Ver.	TUSIGN8 [3]	Version and item number of device software package.
2741	FW Device Part Nr.	TUSIGN8 [20]	
2030	FW Motherboard Ver.	TUSIGN8 [3]	Version and checksum (CRC) of the motherboard software (MB) in the transmitter.
2102	FW Motherboard CRC	TUSIGN16 [1]	
2004	FW Frontend Ver.	TUSIGN8 [3]	Version and checksum (CRC) of the frontend board (FEB) software in the sensor.
2101	FW Frontend CRC	TUSIGN16 [1]	

... 5 Parameter descriptions

... Parameter range – Device Info

Modbus register address	Parameter name	Data type [register length] / value range	Description
... / ...Transmitter / ...Transmitter Version			
2036	HW Motherboard Ver.	TUSIGN8 [1]	Hardware version motherboard
2007	HW Frontend Ver.	TUSIGN8 [1]	Hardware version frontend board
2033	Bootloader MB Ver.	TUSIGN8 [3]	Bootloader version motherboard
2008	Bootloader FEB Ver.	TUSIGN8 [3]	Bootloader version frontend board
2037	Curr. Out FW Ver.	TUSIGN8 [3]	Current output module software version and checksum (CRC).
2103	Curr. Out FW CRC	TUSIGN16	
... / ...Transmitter / Calibration			
2019	First Cal. Date	TUSIGN8 [3]	Date of first calibration of transmitter (calibration of new device).
2025	Last Cal. Date	TUSIGN8 [3]	Date of last calibration of transmitter.
2601	Cal. Cert. No.	TCHAR [20]	Identification (no.) of the relevant calibration certificate.
2621	First Cal. Location	TCHAR [20]	Place of first calibration of transmitter.
2641	Last Cal. Location	TCHAR [20]	Place of last calibration of transmitter.

Parameter range – Device Setup

Modbus register address	Parameter name	Data type [register length] / value range	Description
... / Access Level			
11	Read Only Switch	TUSIGN8 [1] 0: Off 1: A	Indicator of the position of the write protection switch. This parameter is read only.
... / Sensor			
3421	Sensor Location Tag	TCHAR [20]	Set the measuring point tagging for the sensor.
3401	Sensor Tag	TCHAR [20]	Set the TAG number of the sensor.
... / Sensor / ...Application Selector			
6081	Application	TUSIGN8 [4] 0: Air 1: Application 1 ... 7: Application 8	Select the application.
6081	Dig.In 0 Application	TABENUM8 [1]	Use of optional digital inputs for application switching. You can switch between four applications by wiring the digital inputs.
6082	Dig.In 1 Application		
6083	Dig.In 2 Application		
6084	Dig.In1+2Application		

Note

The numbers in brackets (1 to 8) in the Modbus register addresses correspond to the associated application 1 to 8.

Modbus register address (application)	Parameter name	Data type [register length] / value range	Description
... / Sensor / ...Application 1 ... 8			
3521 (1), 3553 (2), 3585 (3), 3617 (4), 3649 (5), 3681 (6), 3713 (7), 3745 (8)	Description	TCHAR [32]	Enter the name of the application 1 to 8.
... / Sensor / ...Application 1 ... 8 / ...A1...Flow meas. – ...A8...Flow meas.			
2201 (1), 2203 (2), 2205 (3), 2207(4), 2209 (5), 2211 (6), 2213 (7), 2215 (8)	Qm Max. DN	TFLOAT [2]	Maximum mass flow for the selected nominal diameter. This parameter is read only
7177 (1), 7223 (2), 7269 (3), 7315 (4), 7361 (5), 7407 (6), 7453 (7), 7499 (8)	Qm Max	TFLOAT [2]	Set the measuring range, maximum mass flow.
7179 (1), 7225 (2), 7271 (3), 7317 (4), 7363 (5), 7409 (6), 7455 (7), 7501 (8)	Qm Min	TFLOAT [2]	Set the measuring range, minimum mass flow.
2217 (1), 2219 (2), 2221 (3), 2223 (4), 2225 (5), 2227 (6), 2229 (7), 2231 (8)	Qv@ Max. DN	TFLOAT [2]	Maximum volume flow for the selected nominal diameter at Qv@ Max. DN. This parameter is read only
7189 (1), 7235 (2), 7281 (3), 7327 (4), 7373 (5), 7419 (6), 7465 (7), 7511 (8)	Qv@ Max	TFLOAT [2]	Set the measuring range, maximum standard volume flow.
7191 (1), 7237 (2), 7283 (3), 7329 (4), 7375 (5), 7421 (6), 7467 (7), 7513 (8)	Qv@ Min	TFLOAT [2]	Set the measuring range, minimum standard volume flow.
7175 (1), 7221 (2), 7267 (3), 7313 (4), 7359 (5), 7405 (6), 7451 (7), 7497 (8)	Damping Q	TFLOAT [2]	Set the damping for flow measurement.
7181 (1), 7227 (2), 7273 (3), 7319 (4), 7365 (5), 7411 (6), 7457 (7), 7503 (8)	Low Flow Cut Off	TFLOAT [2]	Set the threshold to activate the low flow cut-off.
7183 (1), 7229 (2), 7275 (3), 7321 (4), 7367 (5), 7413 (6), 7459 (7), 7505 (8)	LowFlow Hysteresis	TFLOAT [2]	Set the hysteresis for the low flow cut off.

... 5 Parameter descriptions

... Parameter range – Device Setup

Modbus register address (application)	Parameter name	Data type [register length] / value range	Description
... / Sensor / ...Application 1 ... 8 / ...A1...Temp. meas. – ...A8...Temp. meas.			
7199 (1), 7245 (2), 7291 (3), 7337 (4), 7383 (5), 7429 (6), 7475 (7), 7521 (8)	Tm Max	TFLOAT [2]	Set the measuring range, maximum measuring medium temperature.
7201 (1), 7247 (2), 7293 (3), 7339 (4), 7385 (5), 7431 (6), 7477 (7), 7523 (8)	Tm Min	TFLOAT [2]	Set the measuring range, minimum measuring medium temperature.
7197 (1), 7243 (2), 7289 (3), 7335 (4), 7381 (5), 7427 (6), 7473 (7), 7519 (8)	Damping Tm	TFLOAT [2]	Set the damping for temperature measurement.
... / Sensor / ...Application 1 ... 8 / ...A1...Pipe type – ...A8...Pipe type			
6085 (1), 6086 (2), 6087 (3), 6088 (4), 6089 (5), 6090 (6), 6091 (7), 6092 (8)	Shape and probe pos.	TUSIGN8 [3] 220: round cross-section, sensor centered 235: round cross-section 245: rectangular cross- section	Select the piping form and sensor position.
7165 (1), 7211 (2), 7257 (3), 7303 (4), 7349 (5), 7395 (6), 7441 (7), 7487 (8)	Inside diameter	TFLOAT [2]	Set the inside diameter of the piping.
7165 (1), 7211 (2), 7257 (3), 7303 (4), 7349 (5), 7395 (6), 7441 (7), 7487 (8)	Duct inner height	TFLOAT [2]	Set the inside height of the channel with rectangular cross-section.
7169 (1), 7215 (2), 7261 (3), 7307 (4), 7353 (5), 7399 (6), 7445 (7), 7491 (8)	Insertion depth	TFLOAT [2]	Set the insertion depth of the sensor with regard to the inside diameter or the inside height. This parameter is relevant only if the sensor position is not centered.
7167 (1), 7213 (2), 7259 (3), 7305 (4), 7351 (5), 7397 (6), 7443 (7), 7489 (8)	Duct inner width	TFLOAT [2]	Set the inside width of the channel with rectangular cross-section.

Modbus register address (application)	Parameter name	Data type [register length] / value range	Description
... / Sensor / ...Application 1 ... 8 / ...A1...Gas data – ...A8...Gas data			
7163 (1), 7209 (2), 7255 (3), 7301 (4), 7347 (5), 7393 (6), 7439 (7), 7485 (8)	Mean Operating Temp.	TFLOAT[2]	Set the average measuring medium temperature of the application.
7161 (1), 7207 (2), 7253 (3), 7299 (4), 7345 (5), 7391 (6), 7437 (7), 7483 (8)	Mean Operating Press	TFLOAT[2]	Set the average measuring medium pressure of the application.
6001 (1), 6011 (2), 6021 (3), 6031 (4), 6041 (5), 6051 (6), 6061 (7), 6071 (8)	Gas Type 1	TUSIGN8 [1] See table Available gas types on page 16.	Gas type and concentration for gas components 1 to 10 of a gas mix.
7001 (1), 7021 (2), 7041 (3), 7061 (4), 7081 (5), 7101 (6), 7121 (7), 7041 (8)	Concentr. Gas Type 1	TFLOAT[2] 10% to 100%	
Note			
Make sure that the gas type with the highest concentration is entered first, followed by the gas type with the second highest concentration and so on. The gas type and the corresponding concentration can be configured via various communication interfaces. The procedure mentioned above must be taken into account. Modbus RTU also provides an alternative input option that differs from the procedure described above. See Parameter range – other functionalities on page 51			
6002 (1), 6012 (2), 6022 (3), 6032 (4), 6042 (5), 6052 (6), 6062 (7), 6072 (8)	Gas Type 2	TUSIGN8 [1]	
7003 (1), 7023 (2), 7043 (3), 7063 (4), 7083 (5), 7103 (6), 7123 (7), 7043 (8)	Concentr. Gas Type 2	TFLOAT[2]	The value range depends on the concentration of gas types with a smaller index. Maximum 0 to 50 %
6003 (1), 6013 (2), 6023 (3), 6033 (4), 6043 (5), 6053 (6), 6063 (7), 6073 (8)	Gas Type 3	TUSIGN8 [1]	
7005 (1), 7025 (2), 7045 (3), 7065 (4), 7085 (5), 7105 (6), 7125 (7), 7045 (8)	Concentr. Gas Type 3	TFLOAT[2]	The value range depends on the concentration of gas types with a smaller index. Maximum 0 to 33.33 %
6004 (1), 6014 (2), 6024 (3), 6034 (4), 6044 (5), 6054 (6), 6064 (7), 6074 (8)	Gas Type 4	TUSIGN8 [1]	
7007 (1), 7027 (2), 7047 (3), 7067 (4), 7087 (5), 7107 (6), 7127 (7), 7047 (8)	Concentr. Gas Type 4	TFLOAT[2]	The value range depends on the concentration of gas types with a smaller index. Maximum 0 to 25 %
6005 (1), 6015 (2), 6025 (3), 6035 (4), 6045 (5), 6055 (6), 6065 (7), 6075 (8)	Gas Type 5	TUSIGN8 [1]	
7009 (1), 7029 (2), 7049 (3), 7069 (4), 7089 (5), 7109 (6), 7129 (7), 7049 (8)	Concentr. Gas Type 5	TFLOAT[2]	The value range depends on the concentration of gas types with a smaller index. Maximum 0 to 20 %

... 5 Parameter descriptions

... Parameter range – Device Setup

Modbus register address (application)	Parameter name	Data type [register length] / value range	Description
6006 (1), 6016 (2), 6026 (3), 6036 (4), 6046 (5), 6056 (6), 6066 (7), 6076 (8)	Gas Type 6	TUSIGN8 [1]	Gas type and concentration for gas components 1 to 10 of a gas mix.
7011 (1), 7031 (2), 7051 (3), 7071 (4), 7091 (5), 7111 (6), 7131 (7), 7051 (8)	Concentr. Gas Type 6	TFLOAT[2]	The value range depends on the concentration of gas types with a smaller index. Maximum 0 to 16.67 %
6007 (1), 6017 (2), 6027 (3), 6037 (4), 6047 (5), 6057 (6), 6067 (7), 6077 (8)	Gas Type 7	TUSIGN8 [1]	
7013 (1), 7033 (2), 7053 (3), 7073 (4), 7093 (5), 7113 (6), 7133 (7), 7053 (8)	Concentr. Gas Type 7	TFLOAT[2]	The value range depends on the concentration of gas types with a smaller index. Maximum 0 to 14.29 %
6008 (1), 6018 (2), 6028 (3), 6038 (4), 6048 (5), 6058 (6), 6068 (7), 6078 (8)	Gas Type 8	TUSIGN8 [1]	
7015 (1), 7035 (2), 7055 (3), 7075 (4), 7095 (5), 7115 (6), 7135 (7), 7055 (8)	Concentr. Gas Type 8	TFLOAT[2]	The value range depends on the concentration of gas types with a smaller index. Maximum 0 to 12.5 %
6009 (1), 6019 (2), 6029 (3), 6039 (4), 6049 (5), 6059 (6), 6069 (7), 6079 (8)	Gas Type 9	TUSIGN8 [1]	
7017 (1), 7037 (2), 7057 (3), 7077 (4), 7097 (5), 7117 (6), 7137 (7), 7057 (8)	Concentr. Gas Type 9	TFLOAT[2]	The value range depends on the concentration of gas types with a smaller index. Maximum 0 to 11.11 %
6010 (1), 6010 (2), 6030 (3), 6040 (4), 6050 (5), 6060 (6), 6070 (7), 6080 (8)	Gas Type 10	TUSIGN8 [1]	
7019 (1), 7039 (2), 7059 (3), 7079 (4), 7099 (5), 7119 (6), 7139 (7), 7059 (8)	Concentr. Gas Type 10	TFLOAT[2]	The value range depends on the concentration of gas types with a smaller index. Maximum 0 to 10 %
... / Sensor / ...Application 1 ... 8 / ...A2...Field Optim. – ...A8...Field Optim.			
7171 (1), 7217 (2), 7263 (3), 7309 (4), 7355 (5), 7401 (6), 7447 (7), 7493 (8)	Offset Qm	TFLOAT [2]	Offset correction of the flow rate measured value.
7173 (1), 7219 (2), 7265 (3), 7311 (4), 7357 (5), 7403 (6), 7449 (7), 7495 (8)	Corr.Factor Qm	TFLOAT [2]	Correction factor for the flow measured value.

Modbus register address	Parameter name	Data type [register length] / value range	Description
... / ...Transmitter			
3461	TX Location TAG	TUSIGN8 [20] Alphanumeric, maximum 20 characters	Enter the measuring point tagging for the transmitter.
3441	TX TAG	TUSIGN8 [20] Alphanumeric, maximum 20 characters	Enter the TAG number for the transmitter.
9011	Perform Device Reset	ACTION [1]	Restarts the device. Compensates for a short interruption of the power supply.
4110	Restore Factory Def.	ACTION [1]	All user-accessible parameters will be reset to the factory default settings.
... / ...Transmitter / ...Feature Settings			
2028	FillMass On/Off	TUSIGN8 [1] 0: Off 1: A	FillMass function present? Off: No FillMass function present. On: FillMass function present.
3233	FillMass Code	TUSIGN16 [1] 0x0000 to 0xFFFF	Sets the device-specific code for activating the FillMass function. To use this function subsequently, contact the ABB service team or sales organization.
2029	VeriMass On/Off	TUSIGN8 [1] 0: Off 1: A	VeriMass function present? Off: No VeriMass function present. On: VeriMass function present.
3234	VeriMass Code	TUSIGN16 [1] 0x0000 to 0xFFFF	Sets the device-specific code for activating the FillMass function. To use this function subsequently, contact the ABB service team or sales organization.

... 5 Parameter descriptions

... Parameter range – Device Setup

Modbus register address	Parameter name	Data type [register length] / value range	Description
... / ...Transmitter / ...Units			
4013	Unit Massflow Qm	TUSIGN8 [1] Refer to Table 3: Standard density units on page 15.	Selection of unit for mass flow (e.g. for the associated parameters and the corresponding process values).
4014	Mass Totalizer	TUSIGN8 [1] Refer to Table 8: Units for the standard volume totalizer on page 16.	Selection of the unit for the mass counters and the pulse outputs.
4015	Volume flow Qv	TUSIGN8 [1] Refer to Table 2: Units for the mass flow on page 15.	Selection of the unit for the volume flow (for example for the associated parameters and the corresponding process values).
4016	Volume Totalizer	TUSIGN8 [1] Refer to Table 9: Pressure units on page 16.	Selection of the unit for the volume totalizers and the pulse outputs.
4018	Std. Conditions Vol@	TUSIGN8 [1]	Set the standard state for calculation of the standard volume flow and standard volume counter.
5075	Special Condition factor	TFLOAT [1]	Enter the factor of the user-defined unit for standard conditions. The factor can be calculated using the following formula: $\text{Factor} = \frac{(\text{Temperature [K]} \times 1013.25 \text{ hPa})}{(273.15 \text{ K} \times \text{pressure [hPa]})}$ The default value is 1.000 (corresponds to 0°C, 1 atm)
3497	Volumeflow Qv@ Name	TCHAR [8] Alphanumeric, maximum 7 characters	Sets the name or abbreviation for the user-defined unit Qv.
3505	Volume@ Tot. Name	TCHAR [8] Alphanumeric, maximum 7 characters	Sets the name or abbreviation for the user-defined unit Qv.
4017	Unit Temperature	TUSIGN8 [1] Refer to Table 6: Units of length on page 15.	Selection of the unit for the temperature (for example for the associated parameters and the corresponding process values).
4020	Pressure	TUSIGN8 [1] Refer to Fehler! Verweisquelle konnte nicht gefunden werden. on page Fehler! Textmarke nicht definiert..	Selection of the unit for the pressure (for example for the associated parameters and the corresponding process values).
4019	Length	TUSIGN8 [1] Refer to Table 7: Units for the mass counter on page 15.	Selection of the unit for length (e.g. for the associated parameters and the corresponding process values).
4021	Density	TUSIGN8 [1] Refer to Table 4: Standard conditions on page 15.	Selection of the unit for density (for example for the associated parameters and the corresponding process values).
3513	Density@ Name	TCHAR [8] Alphanumeric, maximum 7 characters	Sets the name or abbreviation for the user-defined density unit.

Modbus register address	Parameter name	Data type [register length] / value range	Description
... / ...Transmitter / ...Custom Units			
3777	Variable 1 Name	TCHAR [8] Alphanumeric, maximum 7 characters	Selection of the unit for external process variables. The transmitter can show two external process variables in the display. The process variables can be transferred from a fieldbus master to the transmitter via the HART®, Modbus® oder PROFIBUS DP® protocol.
3785	Variable 2 Name	TCHAR [8] Alphanumeric, maximum 7 characters	You can configure the indicator through the 'Display' menu.
3481	Mass flow Qm Name	TCHAR [8] Alphanumeric, maximum 7 characters	Set the notation for the user-defined unit Qm.
5071	Mass flow Qm Factor	TFLOAT [2] 0.0001 to 100000 kg/h	Set the factor in kg/h for the user-defined unit Qm.
3489	Mass Tot. Name	TCHAR [8] Alphanumeric, maximum 7 characters	Set the notation of the unit for the user-defined mass counter.
5059	Mass Tot. Factor	TFLOAT [2] 0.0001 to 100000 kg	Sets the factor of the unit for the user-defined mass counter.
3497	Volumeflow Qv@ Name	TCHAR [8] Alphanumeric, maximum 7 characters	Set the notation for the user-defined unit Qv@.
5073	Volumeflow Qv@ Fact.	TFLOAT [2] 0.0001 to 100000 m ³ /h@	Set the factor in m ³ /h for the user-defined unit Qv@.
3505	Volumeflow Qv@ Name	TCHAR [8] Alphanumeric, maximum 7 characters	Sets the name or abbreviation of the user-defined unit for the standard volume totalizer.
5063	Volume@ Tot. Factor	TFLOAT [2]	Sets the factor of the user-defined unit for the standard volume totalizer in liters.
3513	Density@ Name	TCHAR [8] Alphanumeric, maximum 7 characters	Set the notation for the user-defined standard density.
5067	Density@ Factor	TFLOAT [2] 0.0001 to 100000 kg/m ³	Set the factor in kg/m ³ for the user-defined unit standard density.

... 5 Parameter descriptions

Parameter range – Display

Modbus register address	Parameter name	Data type [register length] / value range	Description
... / Display			
4127	Language	TUSIGN8 [1] 0: English 1: German 2: Français 3: Español 4: Italiano 9: Polski 11: Chinese 13: Turce	Selection of menu language.
4072	Contrast	TUSIGN8 [1] 0 to 100	Contrast setting for the LCD display.
4071	Autoscroll	TUSIGN8 [1] 0: Deactivated 1: Activated	If Multiplex mode is enabled, you can also activate the 'Autoscroll' function on the information level of the operator menu. In this function, operator pages are automatically displayed in succession on the process screen, changing every 10 seconds. Manual scrolling through pre-configured operator pages as described above is no longer necessary. When Auto scroll mode is enabled, the icon ⤴ is displayed in the lower left corner of the screen. Default setting: disabled.
4073	Mass Flow Format	TUSIGN8 [1]	Selection of number of decimal places used to display the corresponding process variables. The selection of decimal places only has an effect on the process variable display in the LCD indicator; the internal counter reading is however not affected by this.
4078	Mass Format	0: X	
4080	Volume Flow@ Format	1: X.X	
4081	Volume@ Format	2: X.XX	
4075	Volume Flow Format	3: X.XXX	
4079	Volume Format	4: X.XXXX 5: X.XXXXX	
4076	Temperature Format	TUSIGN8 [1]	
4074	Density@ Format	0: X	
4077	Density Format	1: X.X 2: X.XX	
4082	Date Format	TUSIGN8 [1] 0: DD-MM-YYYY 1: MM-DD-YYYY 2: YYYY-MM-DD	Set the display format for the date and time.
4126	Display Tag	TUSIGN8 [1] 0: Off 1: Measuring point tagging 2: Bus address 3: HART address	Selection of the displayed data in the 'measuring point tagging' field of the process display.

Modbus register address	Parameter name	Data type [register length] / value range	Description
4122	Display Rotation	TUSIGN8 [1] 0: Rotation 0° 1: Rotation 180°	Rotation of the display content by 180°. The function of the operating buttons is adapted accordingly.
... / Display / ...Operator Pages / ...Operator Page 1 bis 4			
Up to four user-specific operator pages (layouts) can be configured for the process display.			
If multiple operator pages have been configured, these can be scrolled through manually on the information level. In the factory setting only Operator Page 1 is enabled.			
4083 (page 1) 4084 (page 2) 4085 (page 3) 4086 (page 4)	Display Mode	TUSIGN8 [1] 0: Off 1: Graphic view 2: 1x4 3: 1x6 A 4: 1x6 A bar 7: 1x9 8: 1x9 bar 9: 2x9 10: 2x9 bar 11: 3x9	Configure each operator page. The following versions can be selected: Off, graphic view, 1x4, 1x6A, 1x6A bar, 1x9, 1x9 bar, 2x9, 2x9 bar, 3x9. Selecting 'Off' deactivates the corresponding operator page. The 'graphic view' is only available for the operator page 1.
4087 (page 1) 4092 (page 2) 4097 (page 3) 4102 (page 4)	1st Line	TUSIGN8 [1]	Selection of process variable displayed in the respective row. See table Available process variables on page 17.
4088 (page 1) 4093 (page 2) 4098 (page 3) 4103 (page 4)	2nd Line		
4089 (page 1) 4094 (page 2) 4099 (page 3) 4104 (page 4)	3rd Line		
4091 (page 1) 4096 (page 2) 4101 (page 3) 4106 (page 4)	Bargraph	TUSIGN8 [1] 0: Volume flow in % 1: Mass flow in %	Selection of process variable displayed as a bar graph.
4091	Graph View	TUSIGN8 [1] See table Available process variables on page 17.	Select the process variable displayed as a graphic view (available only for user page 1).

... 5 Parameter descriptions

Parameter range – Input/Output

Modbus register address	Parameter name	Data type [register length] / value range	Description
... / ...Curr.Out 31/32/Uco			
4128	Loop Current Mode	TUSIGN8 [1] 0: Multi-drop fixed value 1: Normal signal. 2: Power mode	Selection of the operating mode for current output 31/32/Uco. <ul style="list-style-type: none"> Multi-drop fixed value: The current output 31/32/Uco supports the HART multi-drop mode, the current output is fixed to 3.6 mA and no longer follows the selected process variable. The process variables can be transferred via the HART protocol. Normal signal.: The current output 31/32/Uco transfers the selected process variable. In addition, the process variables can be transferred via the HART protocol. Power mode: The current output 31/32/Uco is set permanently to 22.6 mA and no longer follows the selected process variable. HART communication is deactivated. The current output 31/32/Uco works as a power supply unit for the operation of the digital output 41 / 42 as an active output.
4074	Output Value	TUSIGN8 [1]	Selection of process variable issued at the corresponding current output. See table Available process variables on page 17.
4048	Curr.Out at Alarm	TUSIGN8 [1] 0: High 1: Low	Selection of status of the current output in error condition. The output 'low' or 'high' current is set in the subsequent parameters.
5039	Low Alarm	TFLOAT [2] 3.5 to 3.6 mA	Sets the current for Low Alarm.
5037	High Alarm	TFLOAT [2] 21 to 22,6 mA	Sets the current for High Alarm.
4049	Curr.Out > 20,5mA	TUSIGN8 [1] 0: Hold last value 1: High alarm 2: Low alarm	Behavior of current output if 20.5 mA is exceeded. <ul style="list-style-type: none"> Hold last value: the last measured value is retained and issued. High alarm: the high alarm current is issued. Low alarm: the low alarm current is issued.
4050	Curr.Out < 3,8mA	TUSIGN8 [1] 0: Hold last value 1: High alarm 2: Low alarm	Behavior of the current output if 3.8 mA is not reached. <ul style="list-style-type: none"> Hold last value: the last measured value is retained and issued. High alarm: the high alarm current is issued. Low alarm: the low alarm current is issued.

Modbus register address	Parameter name	Data type [register length] / value range	Description
... / ...Dig.Out 41/42			
4043	Mode	TUSIGN8 [1] 0: Off 1: Binary 2: Frequency 3: Pulse	Selection of the operating mode for the digital output 41 / 42. <ul style="list-style-type: none"> Off: Digital output deactivated. Binary: Digital output functions as binary output (for function, see the parameter 'Signal Source Binary'). Frequency: Digital output functions as frequency output (for process value see the parameter 'Signal Source Freq..'). In frequency mode, a frequency proportional to the flow rate is given as output. The maximum frequency can be configured in accordance with the upper range value. Pulse: Digital output functions as pulse output (for process value, see the parameter 'Signal Source Pulse'). In pulse mode, pulses per unit are output (e.g. 1 pulse per m³).
... / ...Dig.Out 41/42 / ...Puls.Out 41/42			The following parameters are only available if the digital output 41 / 42 has been configured as a pulse output.
4026	Signal Source Pulse	TUSIGN8 [1]	Selection of the process value issued via the pulse output. See Available process variables on page 17
5027	Quantity Pulses	TFLOAT	Setting of pulses per mass flow unit and per pulse width for the pulse output.
5031	Quantity Mass Quantity Volume@	0.001 to 100,000 pulses	The pulse value and the pulse width are dependent on each other and on the limit frequency of the digital output and are calculated dynamically.
5029	Pulse Width	TFLOAT 0.05 to 2000 ms	
... / ...Dig.Out 41/42 ...Freq.Out 41/42			The following parameters are only available if the digital output 41 / 42 has been configured as a frequency output.
4022	Signal Source Freq.	TUSIGN8 [1]	Selection of the process value issued via the frequency output. Refer to Available process variables on page 17.
5023	Lower Range Value	TFLOAT 0.0 to 10000 Hz	Set the frequency for the lower range value. The entered value corresponds to 0 % flow.
5025	Upper Range Value	TFLOAT 0.0 to 10000 Hz	Set the frequency for the upper range value. The entered value corresponds to 100 % flow.

... 5 Parameter descriptions

... Parameter range – Input/Output

Modbus register address	Parameter name	Data type [register length] / value range	Description
... / ...Dig.Out 41/42 / ...Binary Out 41/42			The following parameters are only available if the digital output 41 / 42 has been configured as a binary output.
4024	Signal Source Binary	TUSIGN8 [1] 0: Off 2: Alarm signal 4: End contact fill function	Selection of binary output function. <ul style="list-style-type: none"> Alarm signal: the binary output functions as an alarm output. The alarm type is selected using the parameters in the '...Alarm Cfg. 41/42' menu. End contact fill function: the binary output is activated when the set fill quantity is reached (only if the FillMass function is activated).
4045	Active Mode	TUSIGN8 [1] 0: Active high (closed) 1: Active low (open)	Select switching properties for the binary output.
... / ...Dig.Out 41/42 / ...Alarm Cfg. 41/42			
4029	General Alarm	TUSIGN8 [1]	Selection of error messages signaled via the binary output 41 / 42.
4030	Qm Massflow Max	0: Off	Only if the parameter 'Signal Source Binary' has been set to 2 - Alarm signal.
4031	Qm Massflow Min	1: On	
4032	Qv@ Volumeflow Max		
4033	Qv@ Volumeflow Min		
4027	Tm Temperature Max		
4028	Tm Temperature Min		
4034	Sensor Soiling		

Modbus register address	Parameter name	Data type [register length] / value range	Description
... / ...Dig.Out 51/52			
4044	Mode	TUSIGN8 [1] 0: Off 1: Binary 2: Frequency 5: 90° phase rotation 6: 180° phase rotation	<p>Selection of the operating mode for the digital output 51 / 52.</p> <p>The operating modes 'Follow DO1', '90°' and '180°' are only available if digital output 41 / 42 has been configured as a pulse output.</p> <ul style="list-style-type: none"> Off: Digital output deactivated. Binary: Digital output functions as binary output (for function, see the parameter 'Signal Source Binary'). Frequency: Digital output functions as frequency output (for process value see the parameter 'Signal Source Freq.'). In frequency mode, a frequency proportional to the flow rate is given as output. The maximum frequency can be configured in accordance with the upper range value. 90° phase rotation: 90° phase rotation of output of the same pulses as for digital output 41 / 42. 180° phase rotation: 180° phase rotation of output of the same pulses as for digital output 41 / 42. <p>Note Digital output 51 / 52 cannot be configured as a second frequency output.</p>
... / ...Dig.Out 51/52 / ...Puls.Out 51/52			
4026	Signal Source Pulse	TUSIGN8 [1]	Selection of the process value issued via the pulse output. See Available process variables on page 17
5027	Quantity Pulses	TFLOAT	Setting of pulses per mass flow unit and per pulse width for the pulse output.
5031	Quantity Mass Quantity Volume@	0.001 to 100,000 pulses	The pulse value and the pulse width are dependent on each other and on the limit frequency of the digital output and are calculated dynamically.
5029	Pulse Width	TFLOAT 0.05 to 2000 ms	
... / ...Dig.Out 51/52 / ...Freq.Out 51/52			
4023	Signal Source Freq.	TUSIGN8 [1]	Selection of the process value issued via the frequency output. Refer to Available process variables on page 17.
5033	Lower Range Value	TFLOAT 0.0 to 10000 Hz	Set the frequency for the lower range value. The entered value corresponds to 0 % flow.
5035	Upper Range Value	TFLOAT 0.0 to 10000 Hz	Set the frequency for the upper range value. The entered value corresponds to 100 % flow.

... 5 Parameter descriptions

... Parameter range – Input/Output

Modbus register address	Parameter name	Data type [register length] / value range	Description
... / ...Dig.Out 51/52 / ...Binary Out 51/52			The following parameters are only available if the digital output 51 / 52 has been configured as a binary output.
4025	Signal Source Binary	TUSIGN8 [1]	See description of digital output 41 / 42.
4046	Active Mode	TUSIGN8 [1]	
... / ...Dig.Out 51/52 / ...Alarm Cfg. 51/52			
4037	General Alarm	TUSIGN8 [1]	Selection of error messages signaled via the binary output 51 / 52.
4038	Qm Massflow Max	0: Off	Only if the parameter 'Output Value Logic' has been set to 2 - Alarm signal.
4039	Qm Massflow Min	1: On	
4037	Qv@ Volumeflow Max		
4038	Qv@ Volumeflow Min		
4039	Tm Temperature Max		
4040	Tm Temperature Min		
4041	Sensor Soiling		
... / ...Dig.Out V3/V4			
4060	Mode	TUSIGN8 [1] 0: Off 1: Binary	Selection of the operating mode for digital output V3 / V4. The operating modes 'Follow DO1', '90°' and '180°' are only available if digital output 41 / 42 has been configured as a pulse output. <ul style="list-style-type: none"> Off: Digital output deactivated. Binary: Digital output functions as binary output (for function, see the parameter 'Signal Source Binary').
... / ...Dig.Out V3/V4 / ...Binary Out V3/V4			The following parameters are only available if the digital output V3 / V4 has been configured as a binary output.
4051	Signal Source Binary	TUSIGN8 [1]	See description of digital output 41 / 42.
4061	Active Mode	TUSIGN8 [1]	
... / ...Dig.Out V3/V4 / ...Alarm Cfg. V3/V4			
4054	General Alarm	TUSIGN8 [1]	Select error messages signaled via the binary output V3 / V4.
4055	Qm Massflow Max	0: Off	Only if the parameter 'Signal Source Binary' has been set to 2 - Alarm signal.
4056	Qm Massflow Min	1: On	
4057	Qv@ Volumeflow Max		
4058	Qv@ Volumeflow Min		
4052	Tm Temperature Max		
4053	Tm Temperature Min		
4059	Sensor Soiling		

Modbus register address	Parameter name	Data type [register length] / value range	Description
... / ...Dig.In V3/V4			
4067	Function	TUSIGN8 [1] 0: Off 1: Reset all Totalizer 3: Set Flowrate to zero 4: Stop all Totalizer 5: Start Batching 7: Act. App.Selector1 3 8: Act. App.Selector2 3	Select a function for the digital input.
4063	Active Mode	TUSIGN8 [1] 0: Active high (closed) 1: Active low (open)	Select switching properties for the digital input.
4065	Delay Time	TUSIGN8 [1] 1: 100ms 5: 500ms 10: 1000ms	Selection of delay time for suppressing EMC faults on the digital input. Note If the digital input has been configured with the function 'Start Batching' the pulse for starting the filling process must fit at least for the set delay time!

... 5 Parameter descriptions

Parameter range – Process Alarm

Modbus register address	Parameter name	Data type [register length] / value range	Description
0 to 95	Diagnosis register	TUSIGN8 [1]	Display of the alarm history. See also chapter Error messages on page 52. The addresses indicated here are read only.
9012	Clear Alarm History	ACTION [1]	The writing of any value deletes the alarm history saved in the device.
... / ...Group Masking			
4069	Maintenance Required	TUSIGN8 [1]	Alarm messages are divided into groups. If masking is activated for a group (On), no alarm occurs. For more detailed information, see chapter Diagnosis / error messages on page 52.
4068	Function Check	0 - Masking deactivated	
4070	Out Of Specification	1 - Masking activated	
... / ...Alarm Limits / ...Application 1			
... / ...Alarm Limits / ...Application 8			
The numbers in brackets (1 to 8) in the Modbus register addresses correspond to the associated application 1 to 8.			
7187 (1), 7233 (2), 7279 Qm Massflow Min (3), 7325 (4), 7371 (5), 7417 (6), 7463 (7), 7509 (8)		TFLOAT [2] 0 to 110 % Factory setting: 0 %	Setting of the alarm limits for the mass flow. If the standard volume flow up-scales or down-scales the values set in the parameters 'Qm Massflow Min' and 'Qm Massflow Max,' error message no. 1 'Mass flow too high / low' is generated.
7185 (1), 7231 (2), 7277 Qm Massflow Max (3), 7323 (4), 7369 (5), 7415 (6), 7461 (7), 7507 (8)		TFLOAT [2] 0 to 130 % Factory setting: 110 %	
7195 (1), 7241 (2), 7287 Qv@ Volumeflow Min (3), 7333 (4), 7379 (5), 7425 (6), 7471 (7), 7517 (8)		TFLOAT [2] 0 to 110 % Factory setting: 0 %	Setting of the alarm limits for the volume flow. If the volume flow up-scales or down-scales the values set in the parameters 'Qv@ Volumeflow Min' and 'Qv@ Volumeflow Max,' error message no. 2 'Volume flow too high / low' is generated.
7193 (1), 7239 (2), 7285 Qv@ Volumeflow Max (3), 7331 (4), 7377 (5), 7423 (6), 7469 (7), 7515 (8)		TFLOAT [2] 0 to 130 % Factory setting: 110 %	
7205 (1), 7251 (2), 7297 Tm Min (3), 7343 (4), 7389 (5), 7435 (6), 7481 (7), 7527 (8)		TFLOAT [2] -100 to 250 °C Factory setting: -20 °C	Setting of the alarm limits for the measuring medium temperature. If the measuring medium temperature up-scales or down-scales the values set in the parameters 'Tm Min' and 'Tm Max,' error message no. 38 'Sensor temperature too high / low' is generated.
7203 (1), 7249 (2), 7295 (3), 7341 (4), 7387 (5), 7433 (6), 7479 (7), 7525 (8)	Tm Max	TFLOAT [2] -50 to 300 °C Factory setting: 200 °C	

Parameter range – Communication

Modbus register address	Parameter name	Data type [register length] / value range	Description
... / ...Modbus			
4007	Device Address	TUSIGN8 [1] 1 to 247	Setting of the Modbus device address. Factory settings: see Parameterization via the Modbus interface on page 6.
4012	IEEE Number Format	TUSIGN8 [1] 0: IEEE-format activated 1: IEEE-format disabled	Selection of the byte order for the Modbus communication. <ul style="list-style-type: none"> If the IEEE format is activated (1), the data words are sent in the 'little-endian' format, with the lowest value word transmitted first. If the IEEE format is deactivated (0), the data words are sent in the standard Modbus 'big-endian' format. Factory setting: IEEE format activated.
4008	Baud Rate	TUSIGN8 [1] 0: 2400 Bd 1: 4800 Bd 2: 9600 Bd 3: 19200 Bd 4: 38400 Bd 5: 56000 Bd 6: 57600 Bd 7: 115200 Bd	Selection of the transmission speed (baud rate) for the Modbus communication. Factory setting: 9600 baud.
4009	Parity	TUSIGN8 [1] 0: None 1: Even 2: Odd	Selection of the parity for the Modbus communication. Factory setting: Odd (odd)
4010	Stop Bits	TUSIGN8 [1] 0: One stop bit 1: Two stop bits	Selection of the stop bits for the Modbus communication. Factory setting: One stop bit
4011	Reponse Delay	TUSIGN8 [1] 0 to 200 ms	Setting of the pause time in milliseconds after receiving a Modbus command. The device sends a response no earlier than expiration of the set pause time. Factory setting: 10 ms

... 5 Parameter descriptions

Parameter range – Diagnostics

Modbus register address	Parameter name	Data type [register length] / value range	Description
... / ...Diagnosis Control			
3313	Preset Maint. cycle	TUSIGN32 [2] 0 to 99999 h	Sets the service interval. After the maintenance interval has expired, the corresponding error message 'Maintenance interval is reached' is set. The setting '0' deactivates the maintenance interval. Factory setting: 0 h
3311	Maint. Remain. Time	TUSIGN32 [2]	Time remaining in the maintenance interval until the error message 'Maintenance interval is reached' is set. The parameter is read only.
9001	Start New Cycle	ACTION [1]	Resetting of the maintenance interval. By writing any value to this address, the maintenance interval is reset to the value set under 'Preset Maint. cycle'.
... / ...Diagnosis Values			
245	Driver Voltage	TFLOAT [2]	Output of the current driver voltage in V. The parameter is read only.
247	Gas Temperature	TFLOAT [2]	Output of current meter tube temperature in °C. The parameter is read only.
223	Transmitter Temp.FE	TFLOAT [2]	Output of current housing temperature in °C. The parameter is read only.
2111	Readback curr. 31/32	TUSIGN16 [1]	Activate the monitoring function for current output 31 / 32. The transmitter measures the actual current and compares the measured value to the set point for the current output. If the measured value deviates from the set point by more than ± 0.4 mA, the current output on the alarm current of 3.3 mA is set and the 'power circuit disrupted' error message is generated. Factory setting off.
... / ...Simulation Mode			
3793	Simulation Switch	TUSIGN8 [1] 0: Off 1: Qm mass [unit] 2: Temperature [unit] 3: Qv @Vol.flow [Unit] 4: Density@ [unit] 5: Qv volume flow [unit] 6: Density [unit] 50: Qm mass [%] 51: Temperature [%] 52: Qv @Vol.flow [%] 53: Density@ [%] 54: Qv volume flow [%] 55: Density [%] 120: Digital output 41/42 121: Digital output 51/52	Manual stimulation of measured values / outputs. The simulated output values correspond to the set measured value (Modbus addresses 71, 72, 341-359). Only one measured value / output can be selected for simulation. After power-up / restart of the device, the simulation is switched off.

Modbus register address	Parameter name	Data type [register length] / value range	Description
Setting of the simulated measured values. The simulated value is selected with the parameter 'Simulation Switch'.			
5021	Curr.Out 31/32/Uco	TFLOAT [2]	Simulation current output 31 / 32 / Uco.
4003	Dig.Out 41/42 State	TUSIGN8 [1] 0 - Off 1 - On	The respective simulated output value is dependent on the operating mode (pulse / frequency) of the digital output 41 / 42.
5017	Freq.Out 41/42 Puls.Out 41/42	TFLOAT [2] 0 to 10500 Hz 0 to 10500 pulses	
4004	Dig.Out 51/52 State	TUSIGN8 [1] 0 - Off 1 - On	
5019	Dig.Out 51/52 Pulse	TFLOAT [2] 0 to 10500 pulses	Only if the digital output 51 / 52 has been configured as a pulse output.
4005	Dig.Out V3/V4 State	TUSIGN8 [1] 0 - Off 1 - On	
4121	Dig.In V3/V4 State	TUSIGN8 [1] 0 - Off 1 - On	
5003	Mass Flow [unit]	TFLOAT [2] 0 to 2 x QmMax DN	Setting of the simulated measured values. The simulated value is selected with the parameter 'Simulation Switch'.
5011	Mass Flow [%]	TFLOAT [2] -200 to 200 %	
5007	Qv@ Vol.flow [unit]	TFLOAT [2] 0 to 2 x QvMax DN	
5015	Qv@ Vol.flow [%]	TFLOAT [2] -200 to 200 %	
5001	Temperature [unit]	TFLOAT [2] -100 to 250 °C	
5009	Temperature [%]	TFLOAT [2] -200 to 200 %	
5005	Volume Flow [unit]	TFLOAT [2] 0 to 2 x QvMax DN	
5013	Volume Flow [%]	TFLOAT [2] -200 to 200 %	

... 5 Parameter descriptions

... Parameter range – Diagnostics

Modbus register address	Parameter name	Data type [register length] / value range	Description
... / ...Output Readings			
243	Curr.Out 31/32/Uco	TFLOAT [2]	Output of the current output values. The available values are dependent on the configuration of the digital outputs. The parameters are read only.
239	Freq.Out 41/42	TFLOAT [2] 0 to 10500 Hz	
18	Dig.Out 41/42 State	TUSIGN8 [1] 0 - Off 1 - On	
241	Freq.Out 51/52	TFLOAT [2] 0 to 10500 Hz	
19	Dig.Out 51/52 State	TUSIGN8 [1]	
20	Dig.Out V3/V4 State	0 - Off	
22	Dig.In V3/V4 State	1 - On	
... / ...SensorCheck			These parameters are only available when the VeriMass function is activated.
... / ...SensorCheck / ...Verify Fingerprint			
9015	Verify	ACTION [1]	Fingerprint testing manual start. The test is started by writing any value to this address. The process takes approx. 12 minutes. Make sure that during this time there is no flow through the sensor (e.g. by shutting or sealing it off).
2047	Result	TFLOAT [2] 0: Incomplete 1+2: Process running 3: Complete 128: General error 129: Sensor temperature error 130: Occupied error 131: Memory access error	Read fingerprint status
2235	Value TDC1	TFLOAT [2]	Read VeriMass parameters
2237	Value TDC2		2035: Temperature change TDC1
2239	Value HDC1		2037: Temperature change TDC2
2241	Value HDC2		2039: Heat emission change HDC1 2041: Heat emission change HDC2

Modbus register address	Parameter name	Data type [register length] / value range	Description
... / ...SensorCheck / ...Install Fingerprint			
9014	Determine	ACTION [1]	Create the commissioning fingerprint. The commissioning fingerprint is created by writing any value to this address. The process takes approximately 12 minutes. Make sure that during this time there is no flow through the sensor (e.g. by shutting or sealing it off).
9013	Delete (New)	ACTION [1]	Delete the commissioning fingerprint. The commissioning fingerprint is deleted by writing any value to this address.
... / ...Diag.CurrOut 31/32			
4123	Readback curr. 31/32		Activate the monitoring function for current output 31 / 32. The transmitter measures the actual current and compares the measured value to the set point for the current output. If the measured value deviates from the set point by more than $\pm 2\%$, the current output on the alarm current of 3.3 mA is set and the 'power circuit disrupted' error message is generated.
9016	Alarm Reset	ACTION [1]	Manual reset of the 'power circuit disrupted' error message. The error message is reset by writing any value to this address.
... / ...Diag.CurrOut 31/32 / ...Alarm Reset Option			
4124	Auto. Reset 10 min		Automatic reset of the 'power circuit disrupted' error message. <ul style="list-style-type: none"> Off: The error is permanently saved and must be reset manually. After the reset, the current output 31 / 32 is retested. On: The error is automatically reset after 10 minutes. After the reset, the current output 31 / 32 is retested.
4125	Auto Reset open Loop		Behavior in the case of an open current output 31 / 32 (interruption of the current loop). <ul style="list-style-type: none"> Off: If the current loop is interrupted, the 'power circuit disrupted' error is generated. The reset of the error then depends on the setting of the 'Auto reset 10min' parameter. On: If the current loop is closed again, the error will automatically reset.

... 5 Parameter descriptions

... Parameter range – Diagnostics

Modbus register address	Parameter name	Data type [register length] / value range	Description
... / ...Alarm Simulation			
4002	xxxx	TUSIGN8 [1] 0: Off 1: Flow Mass Reached 2: Flow Volume Reached 3: Simulation Alarm 4: Flowrate to Zero 5: Maint. Cycle Time 6: Totalizer Stop 7: Totalizer Reset 8: Totalizer Rollover 9: Dev. not calibrated 10: NV defect on FEB 11: NV data defect 12: FEB not detected 13: FEB comm. error 14: Incompatible FEB 15: NV defect on MB 16: DO 41/42 Saturated 26: Volt. Monitoring MB 27: ADC Failure FE 28: Elec. defect FE 29: Sensor Temp. Max. 30: Elec.Temp.Max.FE 31: Sensor Meas. Failure 32: Sensor Power Max. 33: Gas Temperature Max. 34: Configuration Error 35: Volume@ overflow 36: Sensor Soiling 37: Volt. Monitor FEB 38: DO 51/52 Saturated 39: Fieldbus module disrupted 40: Power circuit disrupted	Manual simulation of alarms / error messages. The simulated alarm is selected by setting the parameter to the corresponding error number of the desired error. See also chapter Error messages on page 52.

Parameter range – Totalizer

Modbus register address	Parameter name	Data type [register length] / value range	Description
... / ...Operation			
9007	Start all Totalizer	ACTION [1]	Start all counters of the device.
9009	Stop all Totalizer	ACTION [1]	Stop all counters of the device.
... / ...Reset Totalizer			
9002	All Totalizer	ACTION [1]	Reset the device counter.
9003	Massflow Qm		
9004	Volumeflow Qv@		
... / ...Preset Totalizer			
5055	Massflow Qm	TFLOAT [2]	Default setting of the device counter.
5057	Volumeflow Qv@		
... / ...FillMass			
			These parameters are only available when the FillMass function is activated.
4108	Batch Process Value	TUSIGN8 [1] 0: Off 65: Standard volumes 66: Mass	Selection of the process value used for the fill operation.
5053	Preset Batch Total.	TFLOAT [2] XX ... XX	Sets the fill quantity using the selected unit. When the defined fill quantity is reached, the configured binary output is activated. Note Before setting the fill quantity, the corresponding process value must be selected with the parameter 'Batch Process Value'.
9006	Reset Cur.Batch Tot.	ACTION [1]	Resets the parameter 'Current Batch Total.' to zero and prepares the next fill operation.
9008	Start Batching	ACTION [1]	Starts the fill operation by writing any value to the corresponding Modbus address.
401	Current Batch Total	TFLOAT [2] XX ... XX	Output of the current fill quantity. Once a fill operation has been started, the quantity already filled is shown here. The counter restarts at zero for each fill operation initiated and then counts up to the set fill quantity. This parameter is read only.
9010	Stop Batching	ACTION [1]	Stops the fill operation by writing any value to the corresponding Modbus address.
3315	Current Batch Counts	TUSIGN32 [2]	Output of the number of fill operations since the last reset. This parameter is read only.
9005	Reset Batch Counts	ACTION [1]	Resets the counter 'Current Batch Counts' by writing an arbitrary value into the corresponding Modbus address.

... 5 Parameter descriptions

... Parameter range – Totalizer

Modbus register address	Parameter name	Data type [register length] / value range	Description
... / ...FillMass / ...Lag Correction			
4107	Mode	TUSIGN8 [1] 0 - Manual 1 - Automatic	<p>These parameters are only available when the FillMass function is activated.</p> <p>Selection of overrun correction.</p> <p>Closing the fill valve takes some time and as a consequence more liquid is added, even though the fill quantity is reached and the contact for closing the valve is actuated.</p> <ul style="list-style-type: none"> Automatic: The overrun quantity is calculated by the transmitter automatically. Manual: The overrun quantity must be determined manually and entered in the selected unit via the parameter 'Quantity.'
5049	Quantity	TFLOAT [2] -0.0 to 100.0	<p>Manually sets the overrun quantity correction value in the selected unit.</p> <p>Closing the fill valve takes some time and as a consequence more liquid is added, even though the fill quantity is reached and the contact for closing the valve is actuated.</p> <p>Only if the parameter 'Mode' has been set to 2 - Manual.</p>
5047	Quantity	TFLOAT [2] Read only or set to 0.0.	Output of the overrun quantity automatically calculated by the transmitter. Only if the parameter 'Mode' has been set to 1 - Automatic.
5045	Factor	TFLOAT [2] 0.0 to 1.0 Factory setting: 0.25	<p>Sets the weighting of the last filling process during automatic calculation of the overrun quantity.</p> <p>The calculation is based on the following formula: New correction value = last correction value + (Factor x correction value during the last fill operation)</p> <ul style="list-style-type: none"> 0.0: No change to correction value. 1.0: The correction value is immediately adjusted to the overrun quantity calculated during the last fill operation.
5051	Time	TFLOAT [2] 0.1 to 10 s Factory setting: 0.1 s	Sets the time for the overrun quantity correction after the fill valve is closed.

Parameter range – other functionalities

Simplified input of the gas type and concentration for the currently selected application

The gas type and concentration can be entered for the currently selected application ('... / ...Sensor / ...ApplicationSelector' menu) using the registers listed below.

Unlike the regular parameters in the '... / ...Sensor / ...Application 1 ... 8 / ...A1...Gas dataA8...Gas data' menu, you do not need to enter the gas type with the highest concentration first, then the gas type with the second highest concentration second, and so on.

This rule therefore does not apply to the following registers, and therefore simplifying the input process.

Modbus register address	Parameter name	Data type [register length] / value range	Description
Gas components			
4129 (1), 4130 (2), 4131 (3), 4132 (4), 4133 (5), 4134 (6), 4135 (7), 4136 (8) 4137 (9), 4138 (10)	Gas Type 1 up to 10	TUSIGN8 [1] See table Available gas types on page 16.	Gas type for gas components 1 to 10 of a gas mix.
7529 (1), 7531 (2), 7533 (3), 7535 (4), 7537 (5), 7539 (6), 7541 (7), 7543 (8) 7545 (9), 7547 (10)	Concentr. Gas Type 1 up to 10	TFLOAT[2] 10% to 100%	Concentration in % for gas components 1 to 10 of a gas mix.

Writing to the last register 7547, separately or as part of a write access to several registers will trigger the parameterization setting. The data entered will then be internally verified.

The following conditions must be met and if they are not met, the parameterization will fail:

- The selected application allows calculated gas mixtures
- The selected application allows more than one type of gas in the gas mixture
- The gas types entered are permitted for the selected application
- The sum of the concentrations is between 99 % and 101 %

If the above conditions are met, the integrated concentration quantities are normalized (the sum of all concentration quantities is always 100 %), the concentration quantities with the corresponding gas types are sorted in descending order (the gas type with the highest concentration is in first place) and then the parameterization for the currently selected application is accepted.

6 Diagnosis / error messages

NOTICE

All Modbus addresses in this chapter are indicated in the format "PLC Base 1".

Error messages

Note

Refer to the associated operating instruction for a detailed error description and information about troubleshooting.

Modbus address		Byte / BitPos.	Error code	Fault message	NAMUR classification
Active	History				
2000	2048	1 / 3	F098.011	No Frontend Board detected. Wrong connection. Defect Frontend.	Failure
2001	2049	3 / 5	F096.029	ADC Failure on Frontend Board.	Failure
2002	2050	2 / 5	F094.021	Safety Alarm Curr.Out 31/32	Failure
2003	2051	4 / 1	F093.033	Sensor failure or disconnected.	Failure
2004	2052	5 / 1	F092.041	FEB voltages outside range.	Failure
2005	2053	3 / 1	F091.025	MB voltages outside range.	Failure
2006	2054	4 / 0	F090.032	Frontend temp. out of range.	Failure
2007	2055	1 / 4	F088.012	FEB communication error.	Failure
2008	2056	2 / 2	F086.018	Curr.Out 31/32 com error.	Failure
2009	2057	1 / 2	F084.010	NV data defect. Data storage irreparable.	Failure
2010	2058	1 / 5	F082.013	Incompatible Frontend Board.	Failure
2011	2059	3 / 6	F080.030	ADC Failure on Frontend Board.	Failure
2012	2060	0 / 3	C078.003	Flowrate to zero	Functional check
2013	2061	0 / 5	C076.005	All totalizer stopp.	Functional check
2014	2062	0 / 6	C074.006	Totalizer reset. Reset of one or more Totalizers.	Functional check
2015	2063	0 / 2	C072.002	Simulation is on! Simulating process/output value	Functional check
2016	2064	3 / 2	C070.026	An alarm is simulated.	Functional check
2017	2065	4 / 2	S060.034	Sensor heat emission limit.	Out of specification
2018	2066	4 / 3	S059.035	Reserved 36	Out of specification
2019	2067	4 / 6	S058.038	Invalid Sensor configuration	Out of specification

Modbus address		Byte / BitPos.	Error code	Fault message	NAMUR classification
Active	History				
2020	2068	3 / 7	S057.031	Sensor temperature out of range.	Out of specification
2021	2069	2 / 0	S052.016	Curr.Out 31/32 is saturated.	Out of specification
2022	2070	2 / 1	S051.017	Curr.Out V1/V2, V3/V4 saturated	Out of specification
2023	2071	2 / 3	S049.019	Option Card 1 com error.	Out of specification
2024	2072	2 / 4	S048.020	Option Card 2 com error.	Out of specification
2025	2073	1 / 7	S047.015	Dig.Out 41/42 is saturated.	Out of specification
2026	2074	0 / 0	S046.000	Mass flowrate exceeds limits.	Out of specification
2027	2075	0 / 1	S044.001	Volume flowrate exceeds limits.	Out of specification
2028	2076	4 / 4	S043.036	Reserved 37	Out of specification
2029	2077	4 / 5	S042.037	Medium temperat exceeds limits.	Out of specification
2030	2078	4 / 7	S041.039	Std.Volume flow exceeds limits.	Out of specification
2031	2079	5 / 0	S040.040	Sensor soiling detected.	Out of specification
2032	2080	1 / 1	M038.009	Sensor memory defective.	Maintenance required
2033	2081	1 / 6	M037.014	NV chips defect on Motherboard.	Maintenance required
2034	2082	2 / 6	M032.022	Curr.Out 31/32 not calibrated.	Maintenance required
2035	2083	2 / 7	M031.023	Curr.Out V1/V2 not calibrated.	Maintenance required
2036	2084	3 / 0	M030.024	Curr.Out V3/V4 not calibrated.	Maintenance required
2037	2085	0 / 7	M028.007	Display value is<1600h at Qmax.	Maintenance required
2038	2086	0 / 4	M026.004	Maintenance interval is reached	Maintenance required
2039	2087	1 / 0	M024.008	Device not calibrated.	Maintenance required

Trademarks

Modbus is a registered trademark of Schneider Automation Inc.

Notes

ABB Measurement & Analytics

For your local ABB contact, visit:
www.abb.com/contacts

For more product information, visit:
www.abb.com/flow

We reserve the right to make technical changes or modify the contents of this document without prior notice. With regard to purchase orders, the agreed particulars shall prevail.
ABB does not accept any responsibility whatsoever for potential errors or possible lack of information in this document.

We reserve all rights in this document and in the subject matter and illustrations contained therein. Any reproduction, disclosure to third parties or utilization of its contents – in whole or in parts – is forbidden without prior written consent of ABB.