

JUMO GmbH & Co. KG
 Delivery address: Mackenrodtstraße 14,
 36039 Fulda, Germany
 Postal address: 36035 Fulda, Germany
 Phone: +49 661 6003-0
 Fax: +49 661 6003-607
 E-mail: mail@jumo.net
 Internet: www.jumo.net

JUMO Instrument Co. Ltd.
 JUMO House
 Temple Bank, Riverway
 Harlow, Essex CM20 2DY, UK
 Phone: +44 1279 63 55 33
 Fax: +44 1279 63 52 62
 E-mail: sales@jumo.co.uk
 Internet: www.jumo.co.uk

JUMO Process Control, Inc.
 8 Technology Boulevard
 Canastota, NY 13032, USA
 Phone: 315-697-JUMO
 1-800-554-JUMO
 Fax: 315-697-5867
 E-mail: info@jumo.us
 Internet: www.jumo.us



Supply unit for transmitters

**Supply unit for 2-wire transmitters
 with isolated standard signal
 for mounting on: DIN rail 35mm x 7.5mm
 DIN rail 15mm
 G rail**

**EN 60715
 EN 60715
 EN 60715**



Brief description

The 707520/... supply unit for transmitters is used to supply 2-wire transmitters. It provides the power for the transmitter, isolates the signal and passes it on to the output. The electrical isolation is provided between supply and intrinsically safe input, between supply and output, and between intrinsically safe input and output.

The unit is intended for industrial application and complies with the corresponding European Standards for ensuring electromagnetic compatibility (EMC). In addition, the transmitter supply unit conforms to the Directives of EN 50 014 and EN 50 020 "Electrical apparatus for use in hazardous areas".

The input is factory-calibrated to 4 – 20mA, at the output there is a choice between the standard signals 0(2) – 10V and 0(4) – 20mA. The transmitter supply unit is built into a polycarbonate housing which can be readily clipped onto three different types of rail. Several units can be mounted close together, to save installation space.

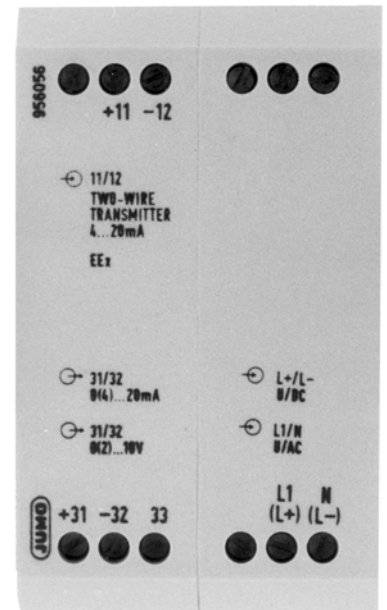

Type 707520/... (with Ex protection)

System diagrams

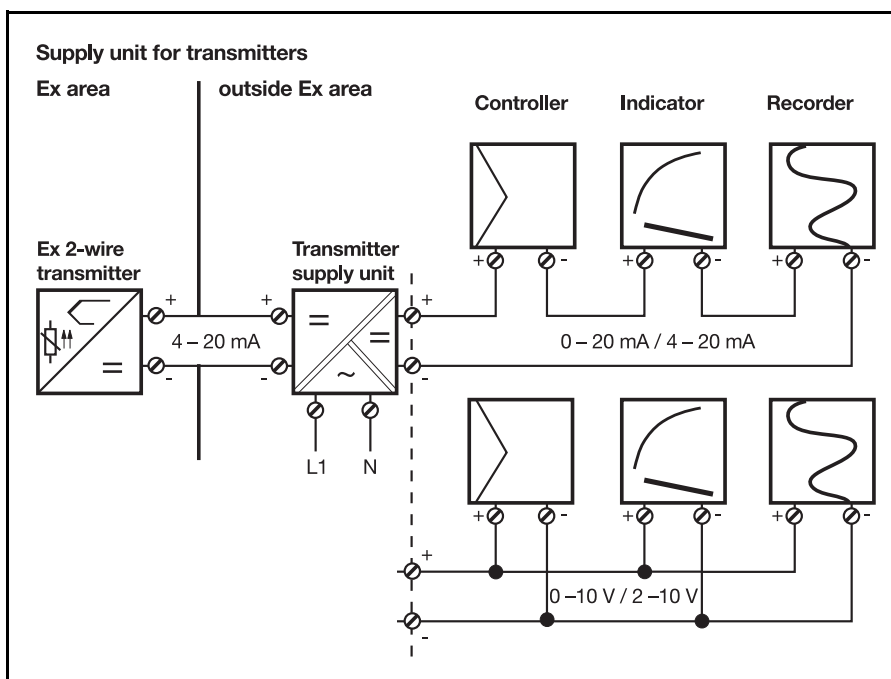

Features

- Ex version
 - ⊕ II (1) G D [Ex ia] IIC or [Ex ia] IIB
 - II (2) G D [Ex ib] IIC or [Ex ib] IIB
- Supply unit to provide power for 2-wire transmitters, electrically isolated

Technical data

Input

Input signal	current 4 – 20mA intrinsically safe
Voltage at transmitter	14V approx. at 20mA

Output

	Current	Voltage
Output signal	0 – 20mA or 4 – 20mA (see order details)	0 – 10V or 2 – 10V (see order details)
Current/voltage changeover	changeover from current to voltage is made through a wire link at terminals 32 and 33 in conjunction with an internal burden resistance of 500Ω.	
Permitted output burden	750Ω max.	250kΩ min. (voltage error through R _{load} 0.2% max.)
Characteristic	linear	
Response to short-circuit at input	I _A > 22 mA	
Response on open input	I _A approx. 0 mA	
Current /voltage limitation	< 30mA	< 20V

Accuracy (referred to the maximum output signal)

Deviation from characteristic	< 0.15%
Time constant	< 50msec
Ripple of output signal	< 1%
Ambient temperature error	< 0.2% per 10°C
Burden error	< 0.1% per 100% change
Supply error per 10%	< 0.05%

Electrical data

Supply AC voltage AC voltage DC voltage	230V AC +10/-15% 48 – 63Hz, 24V AC +10/-15% 48 – 63Hz, 18 – 32V DC +0/-0%
Power consumption at rated voltage	AC: 3VA approx. DC: 2.2W approx.
Permitted ripple within the specified voltage limits	< 2.5V _{p-p}
Isolation between	supply and intrinsically safe input supply and output intrinsically safe input and output
Insulation voltage	The intrinsically safe supply circuit has a safe isolation up to a summed peak value of 375V for the nominal voltages from those circuits which are not intrinsically safe.
Electrical safety	overvoltage category II, pollution degree 2 to EN 61 010
EMC - interference emission - immunity to interference	EN 61 326 Class B to industrial requirements

Ambient conditions

Permissible ambient temperature	-20 to +65°C
Storage temperature	-40 to +85°C

Housing

Material	polycarbonate
Protection	IP20 to DIN 40 050
Mounting	on DIN rail and G rail according to EN 60715 inside the non-hazardous area
Weight	350g

**Ex protection****Extract from the EC Type-Examination Certificate DTM 01 ATEX E 137**

Marking	Ex II (1) G D [EEx ia] IIC or [EEx ia] IIB II (2) G D [EEx ib] IIC or [EEx ib] IIB
Ambient temperature range	$-20^{\circ}\text{C} \leq T_a \leq +65^{\circ}\text{C}$
Non-intrinsically safe circuits	
Supply circuit (auxiliary supply)	
Operating voltage	$U_n = 230\text{V AC } +10/-15\%, 48 - 63\text{Hz}$ or $U_n = 24\text{V AC } +10/-15\%, 48 - 63\text{Hz}$ or $U_n = 18 - 32\text{V DC } \pm 0\%$ $U_m = 250\text{V AC}$
Signal circuit	
Voltage	15V DC $U_m = 250\text{V AC}$
Intrinsically safe supply and signal circuit	
Maximum safe values - voltage - current - power - characteristic	$U_o = 25\text{V DC}$ $I_o = 87.4\text{mA}$ $P_o = 547\text{mW}$ linear
Max. permissible external inductance/capacitance EEx ia IIC / EEx ib IIC EEx ia IIB / EEx ib IIB for combined operation: EEx ia IIC EEx ia IIB	$L_o = 4\text{mH} / C_o = 105\text{nF}$ $L_o = 15\text{mH} / C_o = 620\text{nF}$ $L_o = 1\text{mH} / C_o = 30\text{nF}$ $L_o = 2\text{mH} / C_o = 18\text{nF}$ $L_o = 3.3\text{mH} / C_o = 152\text{nF}$ $L_o = 5\text{mH} / C_o = 130\text{nF}$
Maximum external inductance-resistance ratio - supply circuit Group IIC - supply circuit Group IIB	$L_o/R_o = 0.065\text{mH}/\Omega$ $L_o/R_o = 0.26\text{mH}/\Omega$

Connection diagram

<p>707520/...</p>	Connection for		Terminals		
		Supply as on nameplate	L1 line	AC	
			N neutral		
		DC	L+		
			L-		
Analog inputs					
	2-wire transmitter 4 – 20mA EEx ia IIC	+11	intrinsically safe circuit lead resistance $R = \frac{14V - U_B}{20mA}$ U _B = min. operating voltage of the 2-wire transmitter that is connected		
		-12			
Analog outputs					
	voltage 0(2) – 10V	+31	R _{load} 250kΩ min.		
		-32			
	current 0(4) – 20mA	33	R _{burden} 750Ω max.		
		wire link to terminal -32			

Current/voltage output

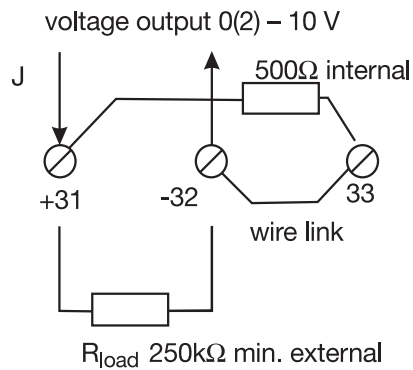
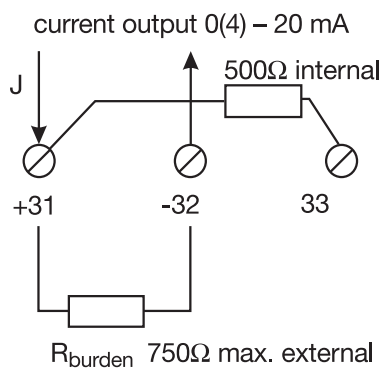

Dimensions

707520/...

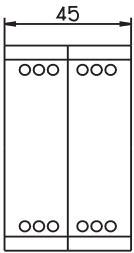

DIN rail 35 mm x 7.5 mm EN 60715

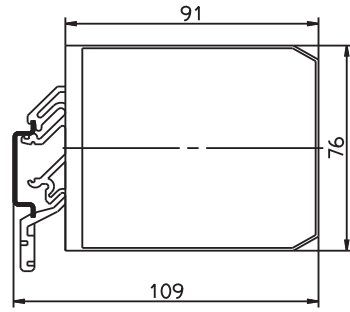

DIN rail 15 mm EN 60715

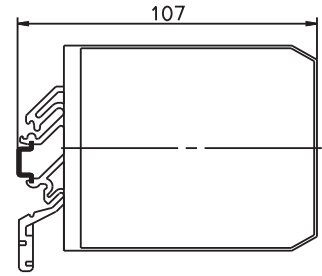

G rail 35 mm EN 60715

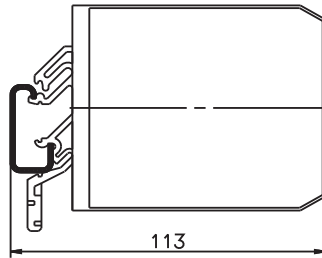

Order details: Supply unit for transmitters

(1) Basic version

707520 Supply unit for 2-wire transmitters
Dimensions: 45 mm x 76 mm x 91 mm (W x H x D)

	(2) Input
x	091 4 – 20mA
	(3) Output (proportional DC current - configurable)
x	030 0 – 20mA/0 – 10V
x	032 4 – 20mA/2 – 10V
	(4) Supply
x	02 230V AC +10/-15%, 48 – 63Hz
x	08 24V AC +10/-15%, 48 – 63Hz
x	24 18 – 32V DC ±0%

Order code

	(1)	(2)	(3)	(4)
	707520	/ 091	-	-

Order example

707520 / 091 - 030 - 02