

JUMO GmbH & Co. KG

Delivery address: Mackenrodtstraße 14,
36039 Fulda, Germany
Postal address: 36035 Fulda, Germany
Phone: +49 661 6003-0
Fax: +49 661 6003-607
E-mail: mail@jumo.net
Internet: www.jumo.net

JUMO Instrument Co. Ltd.

JUMO House
Temple Bank, Riverway
Harlow - Essex CM20 2DY, UK
Phone: +44 1279 63 55 33
Fax: +44 1279 63 52 62
E-mail: sales@jumo.co.uk
Internet: www.jumo.co.uk

JUMO Process Control, Inc.

8 Technology Boulevard
Canastota, NY 13032, USA
Phone: 315-697-JUMO
1-800-554-JUMO
Fax: 315-697-5867
E-mail: info@jumo.us
Internet: www.jumo.us



Electronic temperature monitors/ temperature limiters and safety temperature monitors/ safety temperature limiters according to DIN EN 14 597

Brief description

The areas of application for (safety) temperature limiters or monitors ((S)TB or (S)TW) are to be found wherever thermal processes need to be monitored, and where the system must be set to a safe condition in the event of a fault.

If the permitted temperature limit is reached or a fault occurs within the permitted temperature range (probe break, short-circuit, component defect, power failure), then the device switches off without any delay.. If the fault is no longer present, then limiters TB and STB must be reset manually. This can be done by means of a reset pushbutton on the instrument, or by an external pushbutton. The flow of energy is only enabled again when the temperature is lower (O-function) or higher (S-function) than the preset temperature limit by the amount of the switching differential. In the event of a short-term supply failure (not exceeding 1min) in the satisfactory range of the system, the instrument will be automatically enabled after the power has been restored. The switching differential is 3°C, 10°C 30°C or 100°C.

The analog setpoint knob for the limit temperature is mounted on the front panel. An unintentional or unauthorized adjustment of the limit setting is prevented by a clear cover which can be lead-sealed.

The devices are intended for use as built-in units for fixing onto standard rails to EN 50022-35. The screw terminals for the electrical connections (for a conductor cross-section of max. 2.5mm²) are on one wiring level. The devices function over defined temperature ranges between 0 and 1800 °C (with extra code "SIL" and "DIN": 0 to 1400°C).

Functional control and regulating instrument

Temperature monitors TW¹

Functional temperature monitors for heat-generating systems, with automatic reset upon activation after the sensor temperature has risen or fallen an amount equal to the switching differential above or below the set limit value. (Function 2B)

Safety control and regulating instruments

Safety temperature monitors STW¹

Safety temperature monitors for heat-generating systems, with automatic reset upon activation after the sensor temperature has risen or fallen an amount equal to the switching differential above or below the set limit value. (Function 2B, 2K, 2P)

Temperature limiter TB¹

Safety temperature limiter for heat-generating systems that can only be reset manually or with a tool. (Functions 2B, 2J, 2V adjustable with tool)

Safety temperature limiters STB¹

Safety temperature limiter for heat-generating systems that can only be reset manually or with a tool. (Functions 2B, 2J, 2V, 2K, 2P and adjustable with special tool)

Block diagram

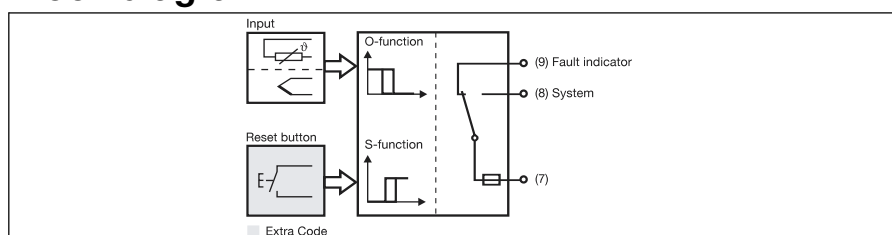

¹For more detailed explanation, see DIN EN 14 597.



Type 701130/ ...

Special features

- Input for RTD temperature probes or twin thermocouples
- O- and S-function for rising and falling temperatures
- Connection for external reset button (TB, STB)
- DIN EN 14 597 approval
- GL approval
- In conjunction with temperature probes as per JUMO data sheet 90.1006 and 90.2006 the devices are certified as per SIL 2 or SIL 3.

O-Function

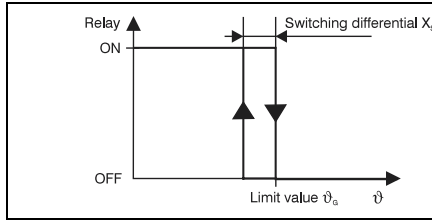

Response in normal operation

- $\vartheta < \vartheta_G$
- temperature rises
- ⇒ the relay drops out at $\vartheta = \vartheta_G$.

Response after falling below the limit

- $\vartheta > \vartheta_G$
- temperature falls
- ⇒ relay pulls in automatically at $\vartheta = \vartheta_G - X_{sd}$ (STW and TW) or must be reset manually (STB and TB)

Response under fault conditions

In the event of a fault (probe break or short-circuit, faulty electronics, supply failure) the relay drops out.

When

- the fault has been cleared
- $\vartheta \leq \vartheta_G - X_{sd}$
- ⇒ for STW and TW: the relay pulls in automatically.
- STB and TB must be reset manually.
- Only in the event of a short-term supply failure (not exceeding 1 min) in the satisfactory range of the system, the instrument will be enabled automatically after the power has been restored.

S-Function

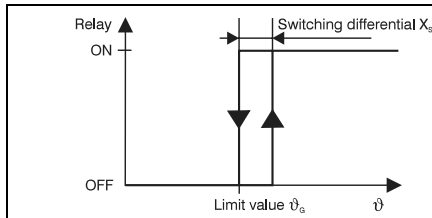

Response in normal operation

- $\vartheta > \vartheta_G$
- temperature falls
- ⇒ the relay drops out at $\vartheta = \vartheta_G$.

Response after falling below the limit

- $\vartheta < \vartheta_G$
- temperature rises
- ⇒ relay pulls in automatically at $\vartheta = \vartheta_G - X_{sd}$ (STW and TW) or must be reset manually (STB and TB)

Response under fault conditions

In the event of a fault (probe break or short-circuit, faulty electronics, supply failure) the relay drops out.

When

- the fault has been cleared
- $\vartheta \geq \vartheta_G + X_{sd}$
- ⇒ for STW and TW: the relay pulls in automatically.
- STB and TB must be reset manually. Only in the event of a short-term supply failure (not exceeding 1 min) in the satisfactory range of the system, the instrument will be enabled automatically after the power has been restored.

Example 1: monitoring heating elements in an incinerator

In the event of a fault, action must be taken to prevent overheating causing damage to the heating elements. The energy flow must be switched off when the furnace temperature has risen above the maximum setpoint value. In this case, a safety temperature limiter with an O-function is used.

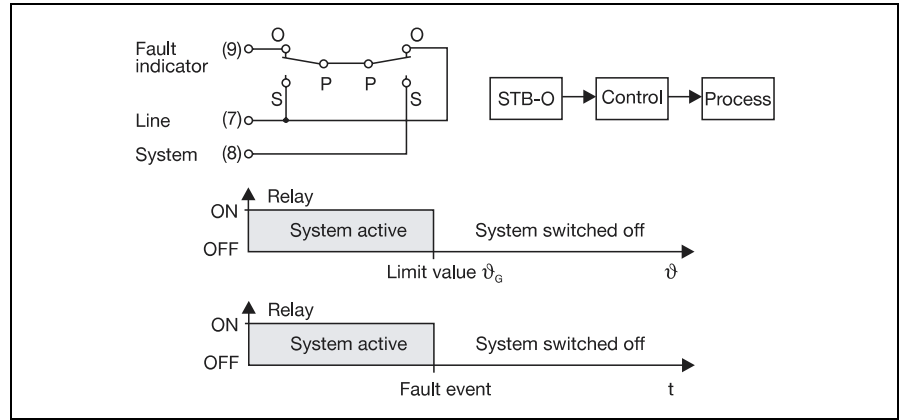

Example 2: Sawdust feed in a furnace

In the event of a fault, action must be taken to prevent a blowback.. The feed of the sawdust must be switched off when the furnace temperature has fallen below the minimum setpoint value. In this case, a safety temperature limiter with an S-function is used.

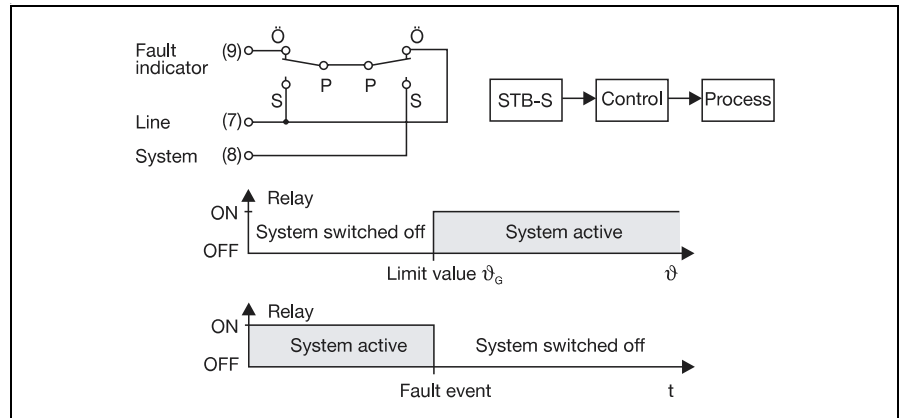

Example 3: Cooling foodstuffs

In the event of a fault, action must be taken to prevent the food becoming spoilt. The system must be switched into continuous operation when the temperature of the cold-storage room is above the minimum setpoint. In this case, a safety temperature limiter with an O-function is used.

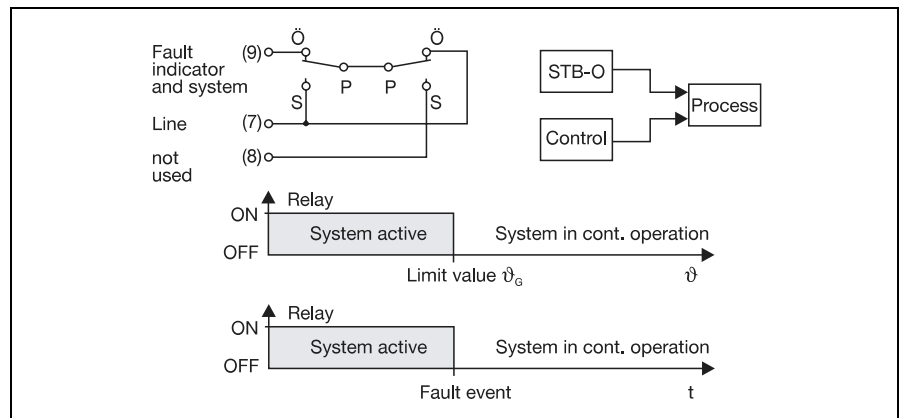

Technical data

Inputs

Permissible measuring ranges must be observed for instruments with approval according to DIN EN 14 597 and SIL certification. Available measurement ranges and temperature sensors are identified by " * ". If other temperature sensors than those described by JUMO datasheets 90.1006 and 90.2006 are used, their registration and suitability for use must be verified.

RTD temperature probes

Pt 100 in 2-wire circuit:

0 to 120°C*, 0 to 300°C*, 0 to 400°C*,
0 to 600°C*, 200 to 500°C*

permissible temperature range for the probes according to DIN and SIL: 0 to 600°C

Ambient temperature error

0,8K/10K

Lead compensation

Standard configuration includes a 0,5Ω internal lead resistor. Also available on request are 1Ω, 10Ω, 30Ω oder 50Ω

For connecting to resistance thermometers, a line compensation resistor LCR (10Ω) is required.

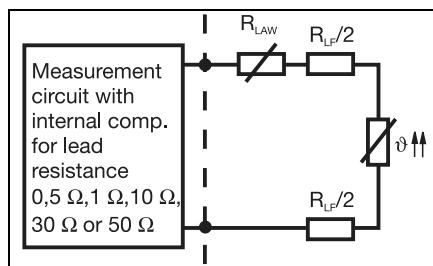

$$RL = R_{LAW} + R_{LF}$$

R_L - internally compensated lead resistance of the measuring circuit

R_{LAW} - resistance of the lead compensation resistor

R_{LF} - resistance of the probe leads

Twin thermocouples

NiCr-Ni K:

200 to 600°C*, 400 to 800°C*,
600 to 1000°C*, 800 to 1200°C

permissible temperature range for probes according to DIN and SIL: 200 to 1000°C

Pt10Rh-Pt S:

400 to 800°C*, 800 to 1200°C*,
1000 to 1400°C, 1200 to 1600°C

permissible temperature range for probes according to DIN and SIL: 400 to 1300°C

Pt30Rh-Pt6Rh B:

800 to 1200°C*, 1000 to 1400°C*,
1200 to 1600°C, 1400 to 1800°C

permissible temperature range for probes according to DIN and SIL: 800 to 1500°C

Fe-CuNi L:

50 to 450°C*, 200 to 600°C*, 500 to 900°C

permissible temperature range for probes according to DIN and SIL: 50 to 700°C

Ambient temperature error

2,0K/10K

Outputs

Relay

with floating SPDT (changeover contact)

Switch rating

2 A, 230 VAC, resistive load
geschützt mit Sicherung 2 A M

Contact life

100,000 switching operations at rated load

General data

Switching point accuracy

±2% of span

Switching differential (Xsd)

3K (only for Pt 100),
10K, 30K or 100K

Voltage supply

230V AC +10%/-15%, 48 to 63Hz,
115V AC +10%/-15%, 48 to 63Hz
24V AC +10%/-15%, 48 to 63Hz

Power consumption

approx. 4VA

Permissible ambient temperature range

0 to 55°C

Permissible storage temperature

-40 to +80°C

Climatic conditions

≤ 75% rel. humidity, no condensation

Protection type

IP 20 (as per EN 60 529)

Electrical safety

as per EN 60 730-1

creepage distances:

- mains to electronic components ≥ 8mm

- mains to relay ≥ 3mm

- relay to electronic components and probe ≥ 8mm

instrument can be connected to SELV circuits.

Test voltages

as per EN 50 178-1

Electromagnetic compatibility

according to EN 61 326

emitted interference: Class B

interference resistance: industrial requirements

Ambient conditions

as per EN 50 178-1

pollution degree 3

Overvoltage category III

Operating conditions

The instrument is designed as a built-in device as per

DIN EN 50 178 5.5.1.3

Operating position

any

Weight

approx. 250g

Dimensions (W x H x D)

54mm x 70mm x 110mm

Case

Plastic

flammability class V0

Extra code GL:

The extra code GL means that the instrument complies with the regulations of Germanischer

Lloyd for use on ships and

maritime installations. The instrument

meets application category C according to the GL guideline.

Temperature: 0 to 55°C

Rel. humidity: not exceeding 100% r.H.

Vibration: not exceeding 0.7g

Serial accessories

- Operating Instructions 70.1130.0

- 2 mounting brackets

(only for GL-version)

- LAW

(only for extra code 229, 231, 233, 235)

Accessories

External reset button RT



Checking

as per EN 60 947-5-1

Contact capability

max. 6A at 230V, 50Hz

Electrical Connection

Via screw terminals 2 x 2,5mm²

Protection type

IP50

Fixing

Safety temperature monitor STW*

Ø 22mm

Weight

approx. 50g

Mounting plate BS

Mounting plate for wall mounting

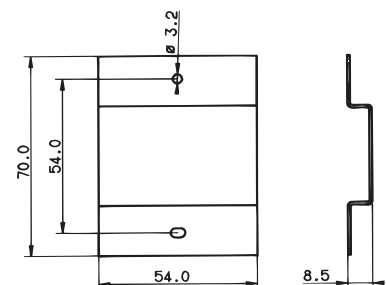

* available measuring ranges and temperature probes.

Response in normal operation

	(1)	Screw terminals, conductor cross section up to max. 2,5mm ²
	(2)	External reset button (only for TB extra code)
	(3)	Limit setting knob
	(4)	Limit scale
	(5)	Fault indicator (S2 only for STB and STW)
	(6)	Lead-sealable clear cover
	(7)	Plastic housing

Connection diagram

Connection for	Connection assignment	
Relay output	7 Pole 8 make contact 9 break contact	
Voltage supply as per nameplate	L1 external conductor N neutral conductor	
External reset button	5 6	
RTD temperature probe in 2-wire circuit	1 2 LAW = lead compensating resistance	
Thermocouple	1 - thermocouple 1 2 + 3 - thermocouple 2 4 +	

Dimensions

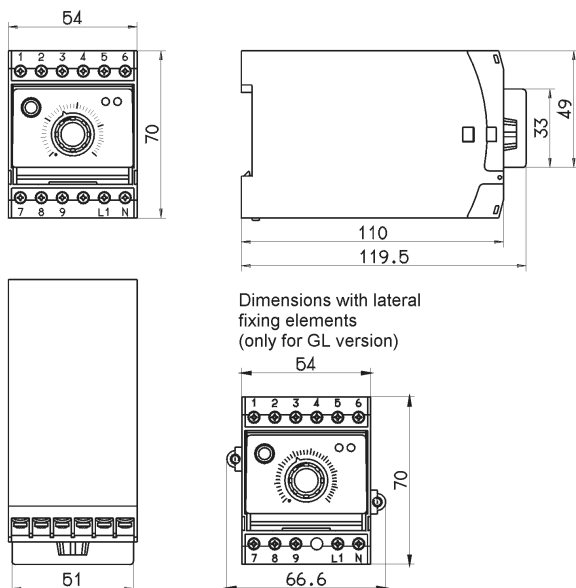

SIL approval

In conjunction with temperature probes as per JUMO data sheet 90.1006 and 90.2006 the instruments are certified as per SIL 2 or SIL 3. If different probes are used, the SIL capability must be calculated using the specified FIT values (λ_{du} channel A).

Instruments as per SIL 2



Type	Designation	SIL device incl. sensor	Architecture		SFF		PFD avg device incl. probe	channel A, device without probe in fit	
			Logic	Sensor	Logic	Sensor		λ_{dd}	λ_{du}
701130/0253-001-XX/XXX	STB-O, w	2	1oo2D	1oo1	69.98	95.60	1,19E-03	64.55	212.71
701130/0153-001-XX/XXX	TB-O, w	2	1oo1	1oo1	77.46		6,72E-03	20.16	124.33
701130/0251-001-XX/XXX	701130/0251-001-XX/XXX	2	1oo2D	1oo1	69.09	95.60	1,22E-03	64.55	221.71
1,22E-03	TW-O, w	2	1oo1	1oo1	75.87		6,72E-03	11.16	133.33
701130/0153-0XX-XX/XXX	TB-O, t	2	1oo1	1oo1	74.38		8,56E-03	35.91	158.21
701130/0151-0XX-XX/XXX	TW-O, t	2	1oo1	1oo1	72.97		8,56E-03	26.91	167.21
701130/0254-001-XX/XXX	STB-S, w	2	1oo2D	1oo1	71.11	95.53	2,12E-03	86.11	206.47
701130/0154-001-XX/XXX	TB-S, w	2	1oo1	1oo1	76.92		8,43E-03	42.1	129.73
701130/0252-001-XX/XXX	STW-S, w	2	1oo2D	1oo1	70.21	95.53	2,15E-03	86.11	215.47
701130/0152-001-XX/XXX	TW-S, w	2	1oo1	1oo1	75.37		8,43E-03	33.1	138.73
701130/0154-0XX-XX/XXX	TB-S, t	2	1oo1	1oo1	76.20		9,55E-03	55.07	153.48
701130/0152-0XX-XX/XXX	TW-S, t	2	1oo1	1oo1	74.84		9,55E-03	46.07	162.48

Instruments as per SIL 3



Type	Designation	SIL device incl. sensor	Architecture		SFF		PFD avg device incl. probe	channel A, device without probe in fit	
			Logic	Sensor	Logic	Sensor		λ_{dd}	λ_{du}
701130/0253-0XX-XX/XXX	STB-O, t	3	1oo2D	1oo2	72.23	90.04	1,95E-04	102.46	213.71
701130/0251-0XX-XX/XXX	STW-O, t	3	1oo2D	1oo2	71.38	90.04	2,04E-04	102.46	222.71
701130/0254-0XX-XX/XXX	STB-S, t	3	1oo2D	1oo2	73.12	90.04	1,85E-04	116.74	203.46
701130/0252-0XX-XX/XXX	STW-S, t	3	1oo2D	1oo2	72.24	90.04	1,94E-04	116.74	212.46

DIN-approved probes for operation in air

RTD temperature probe as per Data Sheet 90.2006	Probe type	Temperatur range ¹	Nom. length mm	Process connection
	2 x Pt100	-170 to +700°C	500, 700 and 1000	Stop flange, movable
2 x Pt100	-170 to +700°C	500, 700 and 1000	Screwed pipe joint G1/2	
Thermocouples as per Data Sheet 90.1006	Probe type	Temperatur range ¹	Nom. length mm	Stop flange, movable
	2 x NiCr-Ni, type K	-35 to +800°C	500, 700 and 1000	
	2 x FeCuNi, type L	-35 to +700°C	500, 700 and 1000	
	2 x NiCr-Ni, type K	-35 to +1000°C	250, 355, 500	
	1 x PT10Rh-PT, type S	0 to 1300°C	250, 355, 500	
	2 x PT10Rh-PT, type S	0 to 1300°C	250, 355, 500	
	1 x PT30Rh-PT6Rh, type B	600 to 1500°C	250, 355, 500	
	2 x PT30Rh-PT6Rh, type B	600 to 1500°C	250, 355, 500	

DIN-approved probes for operation in water and oil

RTD temperature probe as per Data Sheet 90.2006	Probe type	Temperatur range ¹	Fitting length mm	Process connection	
	1 x Pt100	-40 to +400°C	100	Screw fitting G1/2	
	2 x Pt100		100		
	2 x Pt100	-170 to +550°C	65 to 670	movable G1/2 compression clamp	
	1 x Pt100		65 to 670		
	1 x Pt100	-170 to +480°C	250	Screw fitting G1/2	
	2 x Pt100		250		
	1 x Pt100	-40 to +480 °C	100, 160, 220	Weldable sleeve	
	1 x Pt100	-40 to +400 °C	190		
	2 x Pt100	-40 to +400 °C	190		
	2 x Pt100	-40 to +480 °C	100, 160, 220		
	3 x Pt100	-40 to +400 °C	100, 160, 220		
	1 x Pt100	-170 to +480°C	100, 160, 220		
	Thermocouples as per Data Sheet 90.1006	Probe type	Temperatur range ¹		Fitting length mm
2 x NiCr-Ni, type K		-35 to +550°C	65 to 670		movable G1/2 compression clamp
1 x NiCr-Ni, type K			65 to 670		
2 x FeCuNi, type L			65 to 670		
1 x FeCuNi, type L			65 to 670		
1 x Fe-CuNi, type L		-35 to +480°C	220	Weld-in pocket	
2 x Fe-CuNi, type L			220		

1. This is the probe temperature range.

The approval of the device does only apply to the temperature ranges listed on page 1/3, which is often smaller than the probe range.

Order details: electronic temperature monitor/ temperature limiter and safety temperature monitor/ safety temperature limiter according to DIN EN 14 597

(1) Basic type	
701130	electronic temperature monitor/ temperature limiter and safety temperature monitor/ safety temperature limiter according to DIN EN 14 597
(2) Basic type extension	
x 0151	Temperature monitor with O-Function (Relay inactive at $v \div v_G$)
x 0152	Temperature monitor with S-Function (Relay inactive at $v \leq v_G$)
x 0153	Temperature limiter with O-Function (Relay inactive at $v \div v_G$)
x 0154	Temperature limiter with S-Function (Relay inactive at $v \leq v_G$)
x 0251	Safety temperature monitors with O-Function ² (Relay inactive at $v \div v_G$)
x 0252	Safety temperature monitors with S-Function ² (Relay inactive at $v \leq v_G$)
x 0253	Safety temperature limiter with O-Function ² (Relay inactive at $v \div v_G$)
x 0254	Safety temperature limiter with S-Function ² (Relay inactive at $v \leq v_G$)
(3) Measuring inputs	
x 001	RTD temperature probe Pt100 in 2-wire circuit
x 042	Fe-Con L
x 043	NiCr-Ni K
x 044	Pt10Rh-Pt S
x 046	Pt30Rh-Pt6Rh B
(4) Voltage supply	
x 02	230V AC +10/-15% 48 to 63Hz
x 05	115V AC +10/-15%, 48 to 63Hz
x 08	24 V AC +10% /-15%, 48 to 63 Hz
(5) Extra codes	
x 202	switching differential 3°C (only for Pt 100)
x 205	Switching differential 10°C
x 206	Switching differential 30°C
x 208	Switching differential 100°C
x 229	Lead resistance 1Ω internally compensated (incl. LAW 10Ω)
x 231	Lead resistance 10Ω internally compensated (incl. LAW 10Ω)
x 233	Leitungswiderstand 30Ω intern berücksichtigen (inkl. LAW 10Ω)
x 235	Lead resistance 50Ω internally compensated (incl. LAW 10Ω)
x 245	Internal reset button
x 056	DIN approval ³
x 057	SIL approval and DIN approval ³
x 062	GL approval (Germanischer Lloyd)

Order code (1) / (2) - (3) - (4) / (5), ...⁴
 Order example 701130 / 0253 - 001 - 02 / 205, 245

² External reset button necessary for annual test (as standard)
³ Only possible if the permissible range values are observed.
⁴ List extra codes in sequence, separated by commas, measurement range must be given in plain text.

Accessories

- External reset button RT
- Mounting plate BS
- Lead compensating resistance LAW (10Ω)

Sales No.:
 70/97097865
 70/00059172
 70/00322800

DIN EN 14 597
 Instruments with approval as per DIN EN 14 597 must only be used in conjunction with the temperature probes specified in the JUMO data sheets 90.1006 and 90.2006. If other temperature probes are used, their registration must be checked.

SIL
 JUMO provides SIL-certified temperature probes that are suitable for the particular instrument. They correspond to the temperature probes as per DIN EN 14 597, which are listed in the data sheets 90.1006 and 90.2006. If other temperature probes are used, their usability must be checked.

Declarations of Conformity
 The Declarations of Conformity can be found on our website at:
www.jumo.net → Products