

JUMO
mTRON

Analogue input module

70.4020
System Manual Part 5

1	Introduction	3
1.1	Preface	3
1.2	Ordering details	3
1.2.1	4 analogue inputs Type 704020/0-	3
1.2.2	8 analogue inputs Type 704020/1-	5
2	Displays and controls	7
3	Overview of functions	9
4	Network variables	11
4.1	Input network-variables Type 704020/0-	11
4.2	Output network-variables Type 704020/0-	12
4.3	Input network-variables Type 704020/1-	13
4.4	Output network-variables Type 704020/1-	14
5	Parameter setting Type 704020/0-	15
5.1	Module settings	16
5.2	Analogue input	17
5.3	Linearisation table	22
5.4	Linearisation	24
5.5	Mathematics	26
5.6	Limit comparator (LC)	29
5.7	Combination alarm	34
6	Parameter setting Type 704020/1-	37
6.1	Module settings	38
6.2	Analogue input	39
6.3	Limit comparator (LC)	43
6.4	Combination alarm	48
7	Specific module conditions	51
7.1	Action after a power failure	51
7.2	Action on errors of communication	51
8	Index	53
9	Data Sheet (appendix)	55

Contents

1.1 Preface



The JUMO mTRON System Manual is addressed to equipment manufacturers and users with appropriate technical know-how. It describes the range of functions of the JUMO mTRON automation system with its modules, and provides all the information required for project design and start-up.

This Part 5 of the System Manual “JUMO mTRON analogue input module” contains all the module-specific information.

Part 1 of the System Manual “General section” summarises the information which applies to all modules.

Part 2 of the System Manual “JUMO mTRON-iTOOL project design software” describes project design for the JUMO mTRON automation system.

1.2 Ordering details

The type designation contains all the factory-configured settings for the analogue inputs (1) and the supply (2).

The supply voltage connected must correspond to the voltage shown on the label.

The label is affixed to the housing.

1.2.1 4 analogue inputs Type 704020/0-

(1) (2)

704020/0- ... - ..

(1) Analogue inputs..... 8 8 8

Measurement input	Inputs			
	1	2	3	4
Pt100 Resistance thermometer	X	X	X	X
Thermocouples				
Fe-Con L				
Fe-Con J				
NiCr-Ni K				
Cu-Con U				
Cu-Con T				
NiCrSi-NiSi N				
Pt10Rh-Pt S				
Pt13Rh-Pt R				
Pt30Rh-Pt6Rh B				

X = factory-set, freely programmable

1 Introduction

Measurement input	Inputs			
	1	2	3	4
Standard signals 0 – 50 mV 10 – 50 mV –50 to +50 mV 0 – 1 V 0.2 – 1 V –1 to +1 V 0 – 10 V 2 – 10 V –10 to +10 V 0 – 20 mA 4 – 20 mA				
AC current 0 – 50mA	–	–		
resistance 0 – 400Ω				
potentiometer 0.1 – 10kΩ				

Special version **999**

Factory-configured to customer specification.

(2) Supply

Type	Code
110 – 240V AC +10/-15% 48 – 63Hz	23
20 – 53V AC/DC 48 – 63Hz	22

1.2.2 8 analogue inputs Type 704020/1-

704020/1- (1)
... - (2)
..

(1) Analogue inputs

Measurement input	Inputs 1–8
Pt100 resistance thermometer in 2-wire circuit	179
Pt1000 resistance thermometer in 2-wire circuit	180
Standard voltage signals: (switchable via JUMO mTRON-iTOOL) 0 – 10 V 2 – 10 V	181
Standard current signals: (switchable via JUMO mTRON-iTOOL) 0 – 20 mA 4 – 20 mA	182

Special version 999

Factory-configured to customer specification.

(2) Supply

Type	Code
110 – 240V AC +10/-15% 48 – 63Hz	23
20 – 53V AC/DC, 48 – 63Hz	22

Neuron-ID

Each module has a 12-digit number by which it can also be clearly identified in the JUMO mTRON-iTOOL project design software. It can be found next to the label.

2 Displays and controls

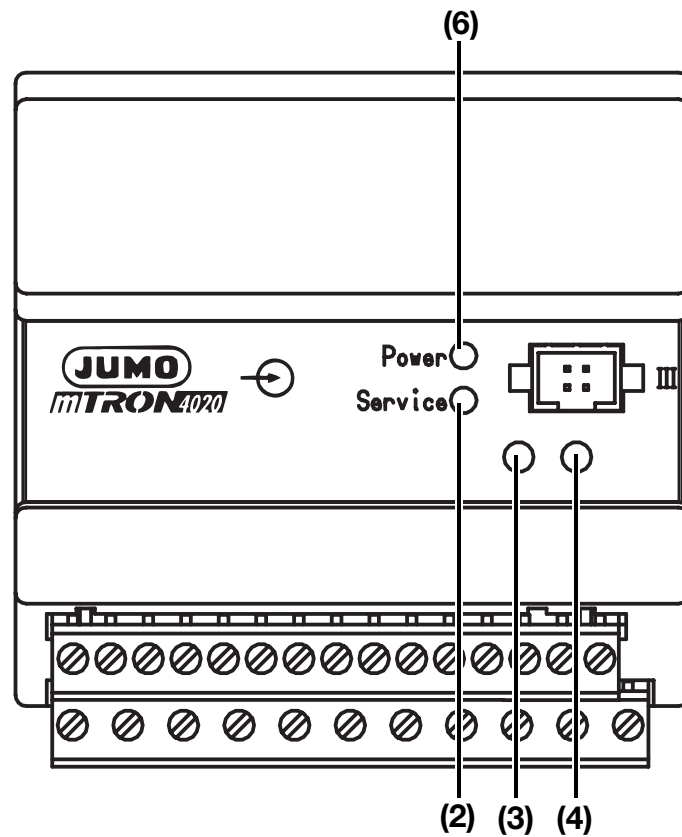

LEDs

(2)	<p>Service LED, red</p> <ul style="list-style-type: none"> - lights up / blinks continuously at one second intervals on operating fault ★ replace module - blinks at one second intervals for 10 sec when the network connection from the JUMOmTRON-iTOOL project design software or the operating unit to the module is being tested by a test signal ("wink"). - long blink pulses (3 sec on, 1sec off) when a Plug & Play error has occurred, - blink pulses (2sec on, 2sec off) when the module is in calibration mode
(6)	<p>Power LED, green</p> <p>lights up when the supply is switched on</p>

Keys/switches

(3)	<p>Switches (termination resistance)</p> <p>⇒ System Manual Part 1 "General section", Section 4.2 "Network connection".</p>
(4)	<p>Installation key</p> <p>the module reports to the JUMOmTRON-iTOOL project design software</p>

2 Displays and controls

Interface

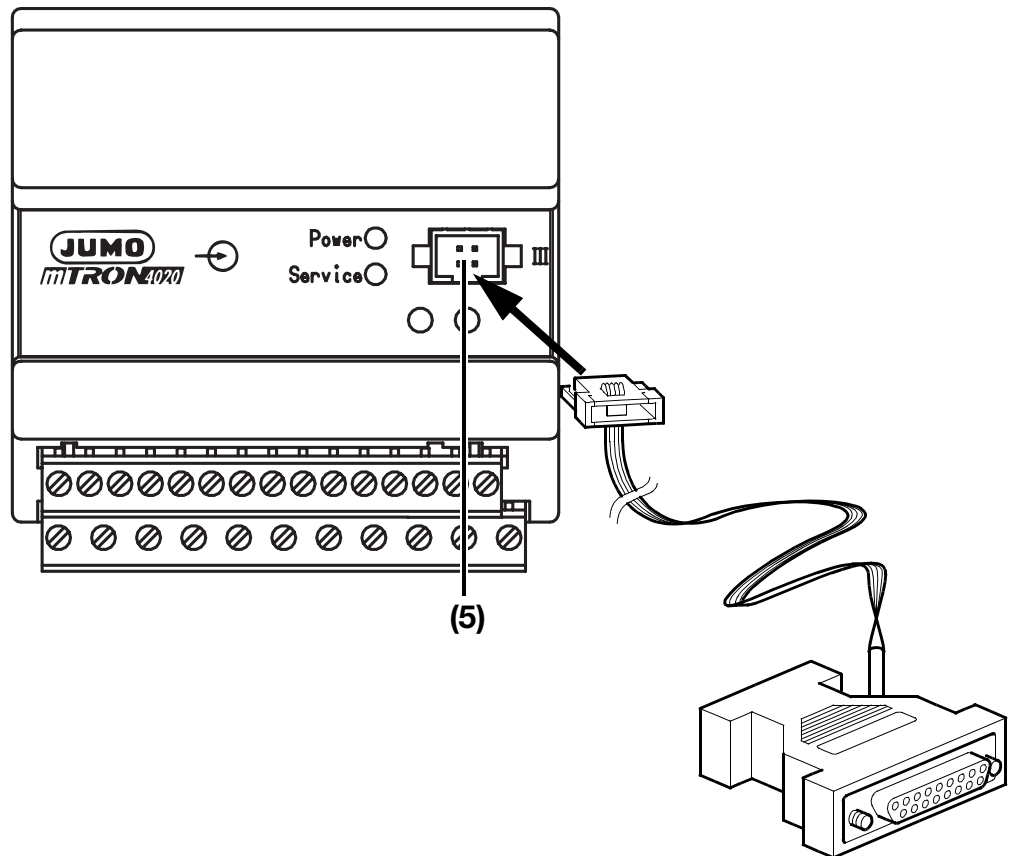

(5) Setup interface

for the setup interface line which links the module to the PC. The parameters can be set via this connector not only for the analogue input module, but also for **all the modules connected to the LON bus.**



When the setup interface line is connected, the module has the sole function of a PC-LON interface converter. All other module functions are switched off.



3 Overview of functions

**Block structure
Type 70.4020/0-**

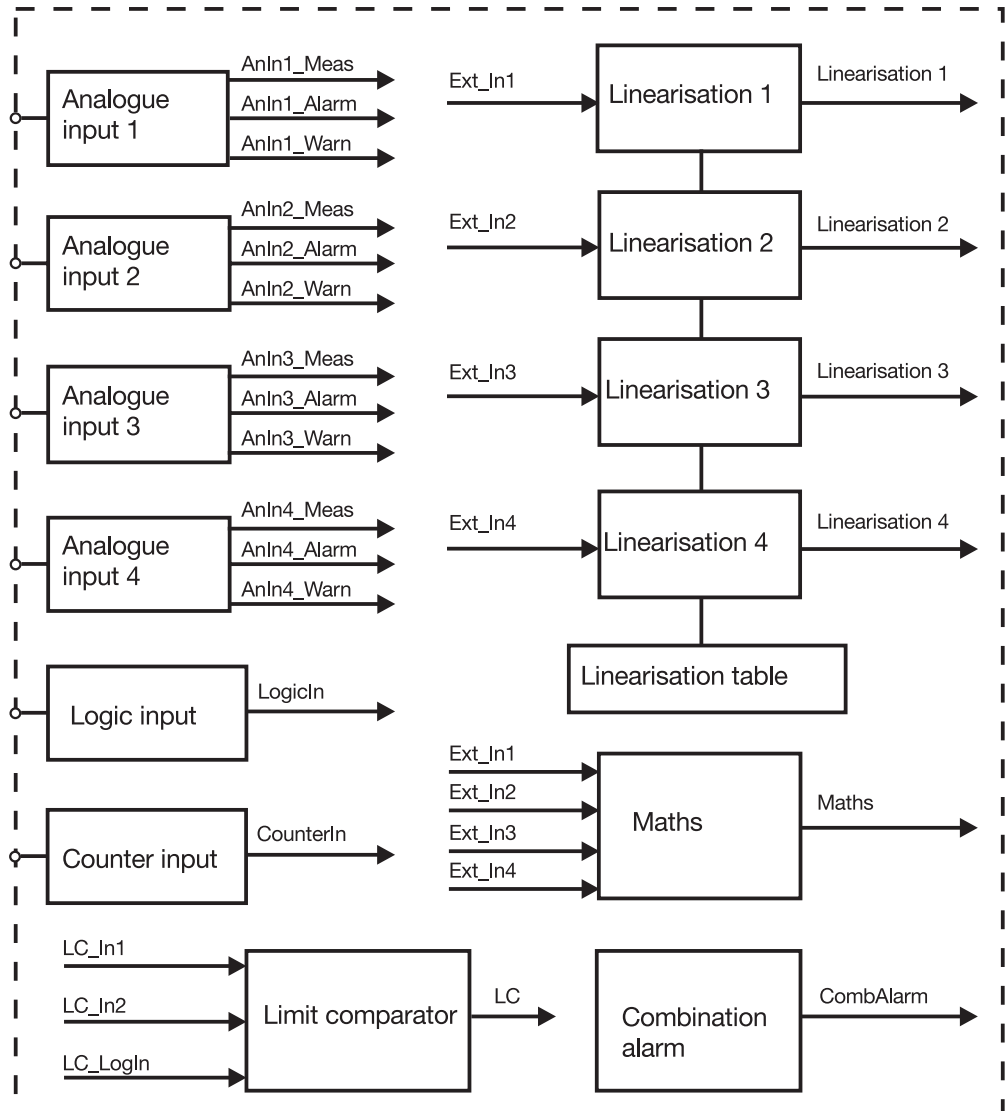
The overview of functions shows the network-variable inputs and outputs of the function blocks.

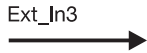

**Explanation of
symbols**

Symbol	Meaning
	Network variable ⇒ Chapter 4 “Network variables”
	Hardware input
	Hardware output

3 Overview of functions

Block structure
Type 70.4020/1-

The overview of functions shows the network-variable inputs and outputs of the function blocks.

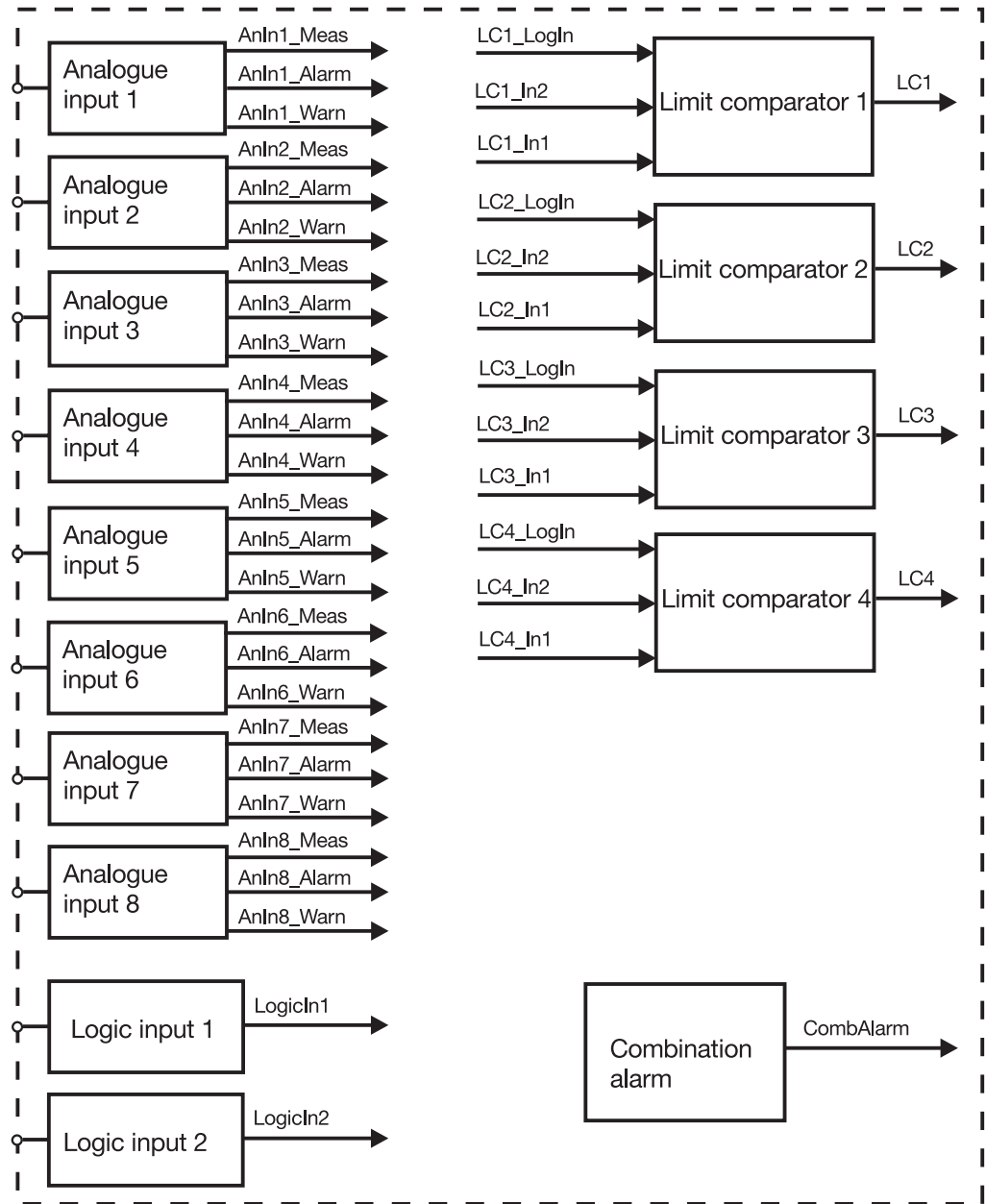

4.1 Input network-variables Type 704020/0-

Input network-variables can be used to transfer values and operating signals from other modules to the analogue input module via the network.

If a bound network-variable is no longer updated, the combination alarm function is activated after 18 sec.

⇒ Section 5.7 “Combination alarm”

List of input network-variables

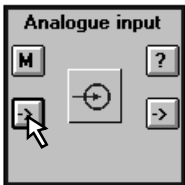

Name	Type	Default	Explanation
Ext_In1	float value	OoR	External input for linearisation 1
Ext_In2	float value	OoR	External input for linearisation 2
Ext_In3	float value	OoR	External input for linearisation 3
Ext_In4	float value	OoR	External input for linearisation 4
LC_LogIn	logic	0	Operating input for limit comparator ⇒ Section 5.6 “Limit comparator (LC)”
LC_In1	float value	OoR	External LC input 1 ⇒ Section 5.6 “Limit comparator (LC)”
LC_In2	float value	OoR	External LC input 2 ⇒ Section 5.6 “Limit comparator (LC)”

Default setting:

Value of the input network-variable in the event of faulty communication and in unbound condition.

OoR = **O**ut of **R**ange (invalid value)

4 Network variables

4.2 Output network-variables Type 704020/0-

Output network-variables can be used to transfer values and operating signals from the analogue input module to other modules via the network.

List of output network-variables

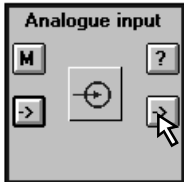

Name	Type	Explanation
AnIn1_Alarm	logic	Alarm signal from analogue input 1
AnIn1_Meas	float value	Measurement from analogue input 1
AnIn1_Warn	logic	Warning signal from analogue input 1
AnIn2_Alarm	logic	Alarm signal from analogue input 2
AnIn2_Meas	float value	Measurement from analogue input 2
AnIn2_Warn	logic	Warning signal from analogue input 2
AnIn3_Alarm	logic	Alarm signal from analogue input 3
AnIn3_Meas	float value	Measurement from analogue input 3
AnIn3_Warn	logic	Warning signal from analogue input 3
AnIn4_Alarm	logic	Alarm signal from analogue input 4
AnIn4_Meas	float value	Measurement from analogue input 4
AnIn4_Warn	logic	Warning signal from analogue input 4
LogicIn	logic	Logics level of the logic input
Linearisation1	float value	Output of linearisation1 function
Linearisation2	float value	Output of linearisation2 function
Linearisation3	float value	Output of linearisation3 function
Linearisation4	float value	Output of linearisation4 function
LC	logic	Logic level of the limit comparator
Maths	float value	Result of the maths function ⇒ Section 5.5 “Mathematics”
CombAlarm	logic	Logic level of the combination alarm function ⇒ Section 5.7 “Combination alarm”
CounterIn	long	Pulse counter referred to 0.8388608sec

4.3 Input network-variables Type 704020/1-

Input network variables can be used to transfer values and operating signals from other modules to the analogue input module via the network.

If a bound network-variable is no longer updated, the combination alarm function will be automatically activated after 18 sec.

⇒ Section 6.4 “Combination alarm”

List of input network-variables



Name	Type	Default	Explanation
LC1_LogIn	logic	0	Operating input for limit comparator ⇒ Section 6.3 “Limit comparator (LC)”
LC1_In1	float value	OoR	External LC input 1 ⇒ Section 6.3 “Limit comparator (LC)”
LC1_In2	float value	OoR	External LC input 2 ⇒ Section 6.3 “Limit comparator (LC)”
LC2_LogIn	logic	0	Operating input for limit comparator ⇒ Section 6.3 “Limit comparator (LC)”
LC2_In1	float value	OoR	External LC input 1 ⇒ Section 6.3 “Limit comparator (LC)”
LC2_In2	float value	OoR	External LC input 2 ⇒ Section 6.3 “Limit comparator (LC)”
LC3_LogIn	logic	0	Operating input for limit comparator ⇒ Section 6.3 “Limit comparator (LC)”
LC3_In1	float value	OoR	External LC input 1 ⇒ Section 6.3 “Limit comparator (LC)”
LC3_In2	float value	OoR	External LC input 2 ⇒ Section 6.3 “Limit comparator (LC)”
LC4_LogIn	logic	0	Operating input for limit comparator ⇒ Section 6.3 “Limit comparator (LC)”
LC4_In1	float value	OoR	External LC input 1 ⇒ Section 6.3 “Limit comparator (LC)”
LC4_In2	float value	OoR	External LC input 2 ⇒ Section 6.3 “Limit comparator (LC)”

Default:

Value of the input network-variables in the event of faulty communication and in unbound condition.

OoR = **O**ut of **R**ange (invalid value)

4 Network variables

4.4 Output network-variables Type 704020/1-

Output network-variables can be used to transfer values and operating signals from the analogue input module to other modules via the network.

List of output network-variables



Name	Type	Explanation
AnIn1_Alarm	logic	Alarm signal from analogue input 1
AnIn1_Meas	float value	Measurement from analogue input 1
AnIn1_Warn	logic	Warning signal from analogue input 1
AnIn2_Alarm	logic	Alarm signal from analogue input 2
AnIn2_Meas	float value	Measurement from analogue input 2
AnIn2_Warn	logic	Warning signal from analogue input 2
AnIn3_Alarm	logic	Alarm signal from analogue input 3
AnIn3_Meas	float value	Measurement from analogue input 3
AnIn3_Warn	logic	Warning signal from analogue input 3
AnIn4_Alarm	logic	Alarm signal from analogue input 4
AnIn4_Meas	float value	Measurement from analogue input 4
AnIn4_Warn	logic	Warning signal from analogue input 4
AnIn5_Alarm	logic	Alarm signal from analogue input 5
AnIn5_Meas	float value	Measurement from analogue input 5
AnIn5_Warn	logic	Warning signal from analogue input 5
AnIn6_Alarm	logic	Alarm signal from analogue input 6
AnIn6_Meas	float value	Measurement from analogue input 6
AnIn6_Warn	logic	Warning signal from analogue input 6
AnIn7_Alarm	logic	Alarm signal from analogue input 7
AnIn7_Meas	float value	Measurement from analogue input 7
AnIn7_Warn	logic	Warning signal from analogue input 7
AnIn8_Alarm	logic	Alarm signal from analogue input 8
AnIn8_Meas	float value	Measurement from analogue input 8
AnIn8_Warn	logic	Warning signal from analogue input 8
LogicIn1	logic	Logic level of logic input 1
LogicIn2	logic	Logic level of logic input 2
LC1	logic	Logic level of limit comparator 1
LC2	logic	Logic level of limit comparator 2
LC3	logic	Logic level of limit comparator 3
LC4	logic	Logic level of limit comparator 4
CombAlarm	logic	Logic level of the combination alarm function ⇒ Section 6.4 “Combination alarm”

5 Parameter setting Type 704020/0-

Basic menu

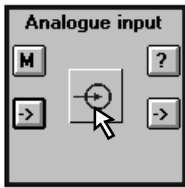

Module name
Name of the module

Setup dialog
The functions of the module are assigned to setup dialogs

OK
for entering and storing all inputs

Cancel
for aborting inputs. The data are not stored

Edit
for editing parameters in the marked setup dialog

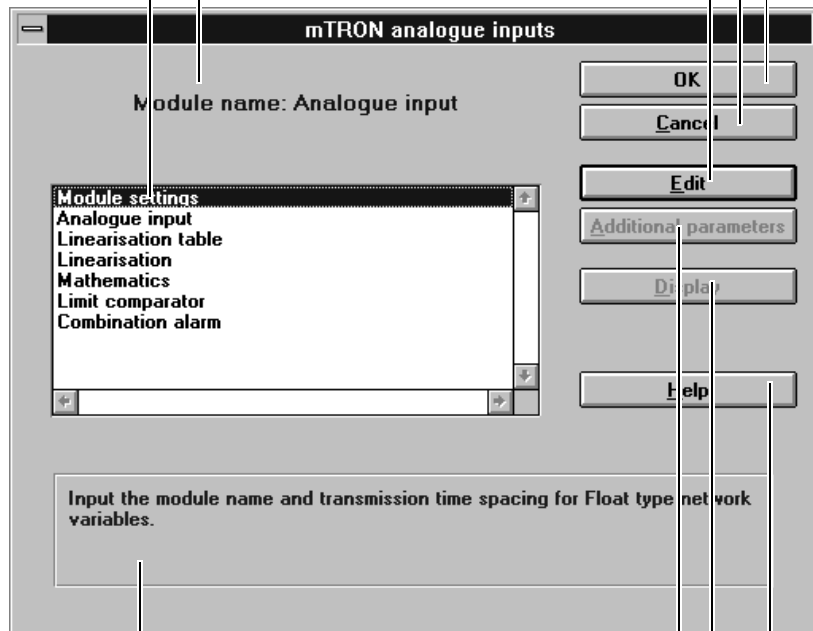

Additional parameters
Further settings can be made here when there are differences between the versions of module software and setup program

Display
Using this function, individual parameters can be removed from the operating unit (parameter level).

Info text
provides information on the setup dialog which is marked

Help
calls up help text for the basic menu

5 Parameter setting Type 704020/0-

5.1 Module settings

A characteristic designation for the task of the module in the process simplifies work on the project.

Setup dialog

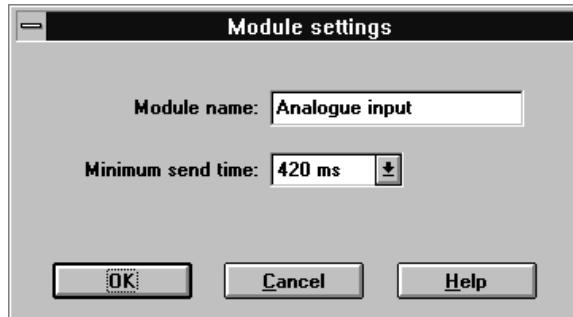

Parameter

Parameter	Selection/settings	Explanation
Module name [16 characters]	Analogue input	Name of the module (16 characters)
Min Send Time [MinSendTim]	n x 420ms max. time = 8.4s 420ms	Determines in which time intervals network variables of the "float value" type are sent via the network The output network-variables of the "float value" type are sent without repetition at intervals of MinSendTime. The output network-variables of the "logic" type are instantly output with 2 repetitions at a status change (0 → 1, 1 → 0). If the status has not changed after 6sec, there is an automatic output to the signal destinations via the network.

■ = factory setting [] = short name in the operating unit

5 Parameter setting Type 704020/0-

5.2 Analogue input

Four measurement inputs measure thermovoltages, resistances and standard signals which are listed in the table.

Setup dialog

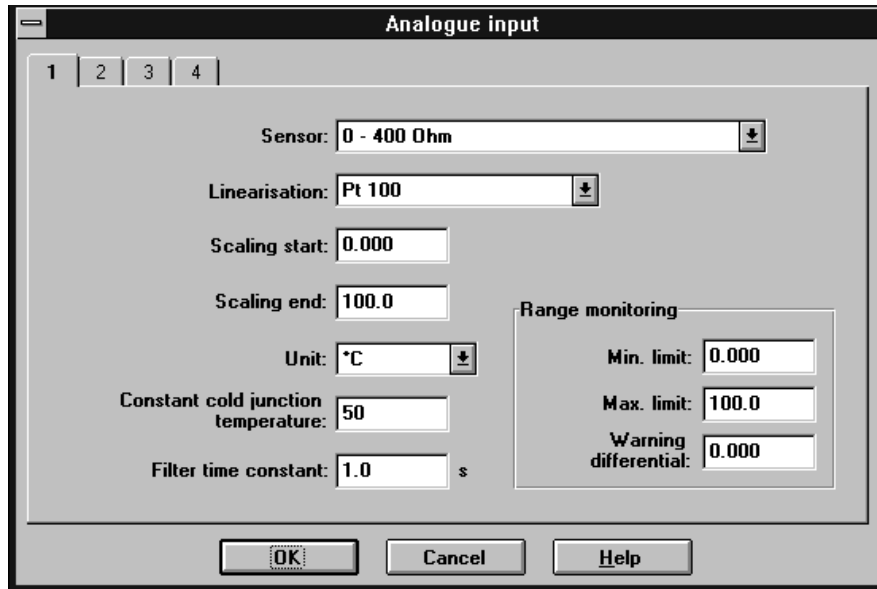

Parameters

Parameter	Selection/settings	Explanation
Meas.input [AnalogInpX]	X= 1 – 4	Selection of the measurement input 1 – 4
Sensor [Sensor]	No sensor connected [NoSens] Thermocouple CJ temperature internal [CJInt] Thermocouple CJ temperature constant [CJ constant] 0– 400 Ohm [3Pt100] Potentiometer [Potent] 0– 50 mV [0/50mV] 0– 10 V [0/10V] 2– 10 V [2/10V] 0–20 mA [0/20mA] 4– 20 mA [4/20mA] 0– 1 V [0/1V] 0.2– 1 V [0.2/1V] 10– 50mV [10/50mV] -1 to +1 V [-/+1V] -10 to +10V [-/+10V] Heater current 0–50mA AC [50mAAC] -50 to +50 mV [-/+ 50mV]	Defines the transducer to be connected to the specific analogue input. 3-wire circuit (for Pt100 transducer).
		Input 3 and 4 only

■ = factory setting [] = short name in the operating unit

5 Parameter setting Type 704020/0-

Parameter	Selection/settings	Explanation
Linearisation [Linearisn]	Linear [Linear] Pt100 [Pt100] Type L Fe-Con [TypeL] Type J Fe-Con [TypeJ] Type K NiCr-Ni [TypeK] Type U Cu-Con [TypeU] Type T Cu-Con [TypeT] Type N NiCrSi-NiSi [TypeN] Type S Pt10Rh-Pt [TypeS] Type R Pt13Rh-Pt [TypeR] Type B Pt30Rh-Pt6Rh [TypeB]	Determines the linearisation function for the sensor
Scaling start [ScalStart]	-1999 +9999 unit 0 unit	With standard signal or potentiometer: Defines the display value (measurement value) of the start value of the input signal range. With Pt100 (sensor: 0 – 400Ω/Pt100 linearisation) or thermocouple: Makes an offset correction.
Scaling end [ScalEnd]	-1999 +9999 unit 100 unit	Defines the display value (measurement value) of the end value of the standard signal or potentiometer range.
Unit [Unit]	°C various	Determines the physical unit of the measurement value.
Constant cold junction temperature [CJTemp]	-5 +100 50	Defines the cold junction temperature of the thermocouple in °C. This is only valid when “Thermocouple constant cold-junction temperature” is selected under the parameter <i>Sensor</i> .
Filter time constant [FiltTime]	0.0 – 40.0sec 1.0sec	The time constant which is used to filter the measurement value with two digital PT1-filters. The value of the filter time constant is effective at all levels.
Min. limit [MinLimit]	-1999 +9999 unit 0.0	If the measured value falls below the preset value, then an alarm is produced ⇒ Section 4.2 “Output network-variables Type 704020/0-”
Max. limit [MaxLimit]	-1999 +9999 unit 100	If the measured value goes above the preset value, then an alarm is produced. ⇒ Section 4.2 “Output network-variables Type 704020/0-”
Warning differential [WarnDiff]	-1999 +9999 unit 0.0	The value of the input produces a warning alarm if: process value > max. limit - warning limit and also if: process value < min. limit + warning limit ⇒ Section 4.2 “Output network-variables Type 704020/0-”

■ = factory setting [] = short name in the operating unit

5 Parameter setting Type 704020/0-

Function

The block structure shows the input and output signals of the function.

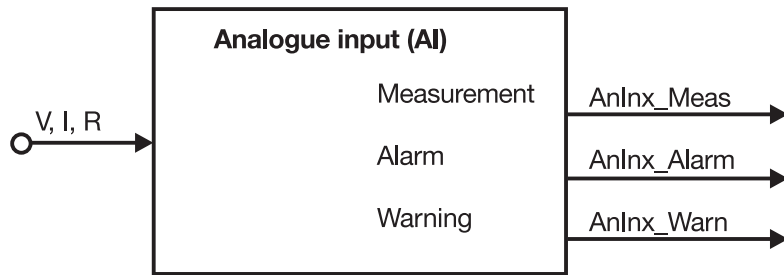

x = 1 – 4

The analogue input module has 4 analogue inputs. The block diagrams below show the processing of the sensor signal, depending on the sensor type, until a measurement is produced.

The following sensors can optionally be connected to the 4 analogue measurement inputs without any alteration to the hardware.

Block structure with thermocouple and resistance

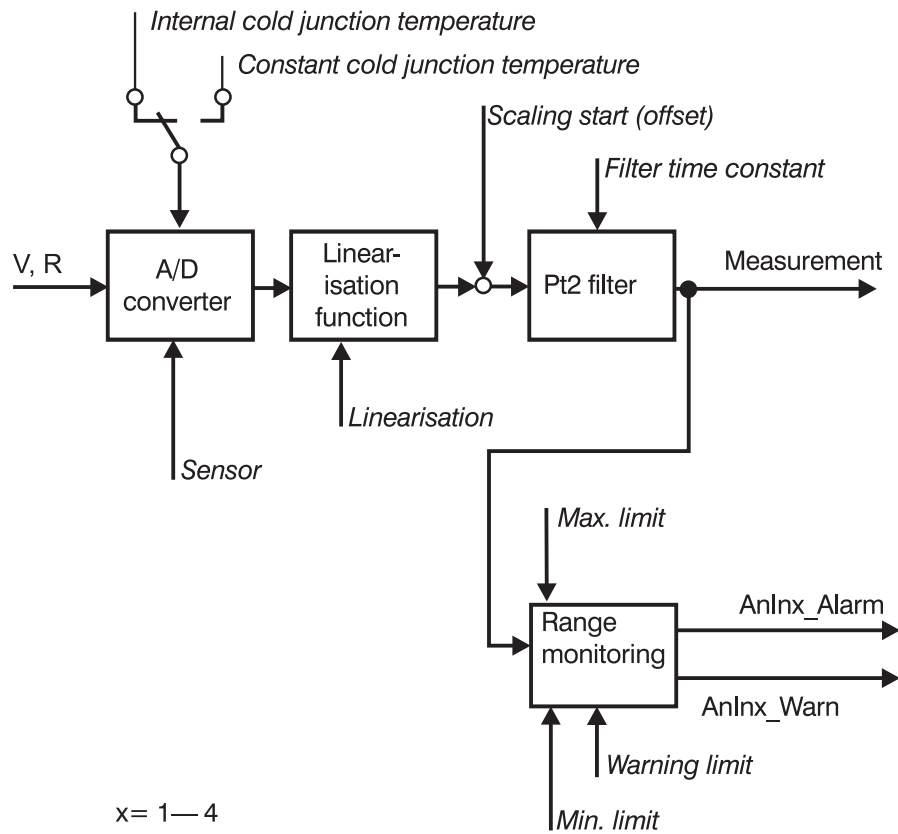

x = 1 – 4

5 Parameter setting Type 704020/0-

Block structure with standard signal, potentiometer and AC current

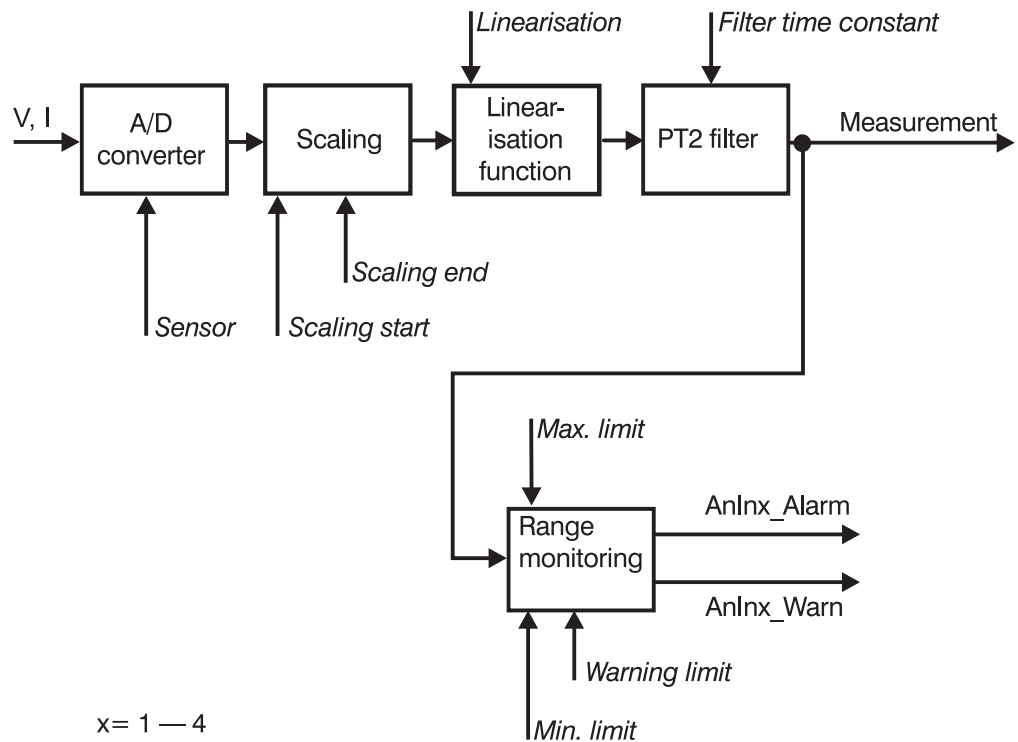

Range monitoring

A range monitoring function is integrated into each of the analogue input functions. This function can be freely set via parameter to monitor the measurement. The alarm signals (AnInx_Alarm, AnInx_Warn) are available as output network-variables and can be used to link up with other functions.

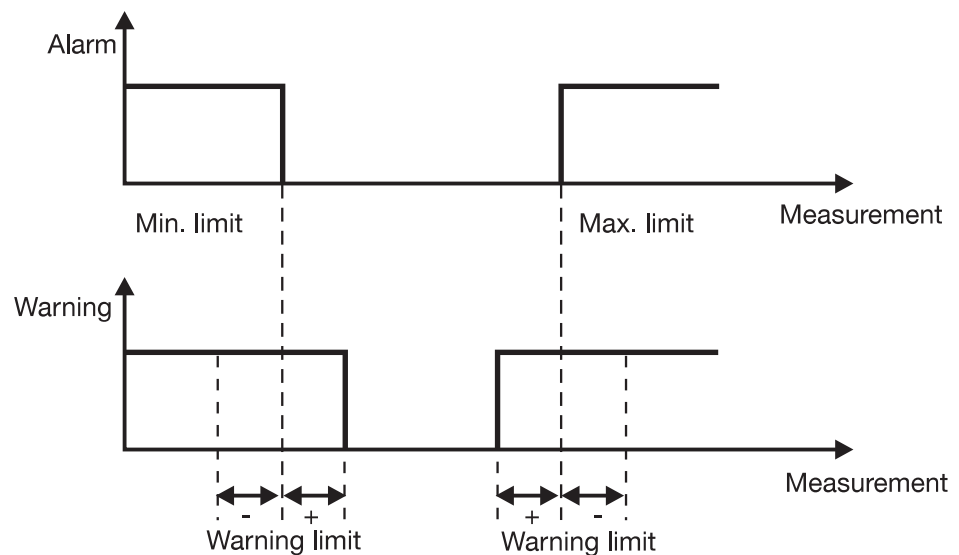

5 Parameter setting Type 704020/0-

Range monitoring On over/underrange of the selected current or voltage input range, the measurement itself is characterised as an invalid value by the “Out of Range” message, so that the operated functions can evaluate the invalid measurement. The table below shows on which sensor signals a sensor break is recognised and reported.

Transducer	Sensor break	Short circuit	Max. overrange
Resistance thermometer	X	X	0%
Thermocouples	X	–	0%
0–50mV	X	–	+/-20%
10–50mV	X	X	+/-20%
-50 to +50mV	X	–	+/-10%
0–10 V	–	–	+/-20%
2–10 V	X	X	+/-20%
-10 to +10 V	–	–	+/-10%
0–1 V	–	–	+/-20%
0.2–1 V	X	X	+/-20%
-1 to +1 V	–	–	+/-10%
0–20mA	–	–	+/-20%
4–20mA	X	X	+/-20%
AC 0–50mA	–	–	+/-10%
Potentiometer	X (slider)	–	0%

X = recognised

– = not recognised

Error treatment In the event of a measurement error (e.g. sensor break),

- the alarm and warning are activated and
- the measurement is set to “Out of Range” (invalid value).

5 Parameter setting Type 704020/0-

5.3 Linearisation table

This function can be used, for example, to input customized linearisations for which there are no linearisations in the JUMO mTRON-iTOOL project design software. This table is valid for all linearisations in the module.

Setup dialog



Linearisation table

	x-value	y-value	x (calculated)	y (calculated)
1	0.000	0.000	0.000	0.000
2	20.00	0.000	1.000	0.000
3			2.000	0.000
4			3.000	0.000
5			4.000	0.000
6			5.000	0.000
7			6.000	0.000
8			7.000	0.000
9			8.000	0.000
10			9.000	0.000
11			10.00	0.000
12			11.00	0.000
13			12.00	0.000
14			13.00	0.000
15			14.00	0.000

Unit: °C

Cold junction temperature: No function

Compensation: 0.0 µV/K

OK

Cancel

Help

Insert Delete

Optimum x Calculate Diagram

Parameters

Parameter	Selection/settings	Explanation
Unit [Unit]	°C various	Determines the physical unit of the measurement.
Cold junction temperature [SelCJTemp]	No function Internal AnIn1_Meas AnIn2_Meas AnIn3_Meas AnIn4_Meas Ext_In1 Ext_In2 Ext_In3 Ext_In4	Indicates the source of the cold junction temperature of the thermocouple which has to be linearised.
Compensation [Compensn]	-199.9 to +999.9. 0	Change of the thermovoltage in the cold junction temperature range

■ = factory setting [] = short name in the operating unit

Optimum x

21 calibration points in the range between **Start x [Start X]** and **End x** are automatically entered into the table (column **x-value**).
A calibration point which is not on the fixed grid, as well as the values for the column **y-value** can subsequently be entered into the table.

Calculate

Calibration points are freshly calculated in the column **x (calculated)**, so that an even grid is produced again [**step X**].
The corresponding newly calculated y-values appear in column **y (calculated)**.

5 Parameter setting Type 704020/0-

Diagram The linearisation curve which is entered is graphically shown in red, the calculated one in white.

Insert Adds a new line below the selected position (click with the mouse), thus erasing calibration point 21.

Delete Deletes one line

Block diagram

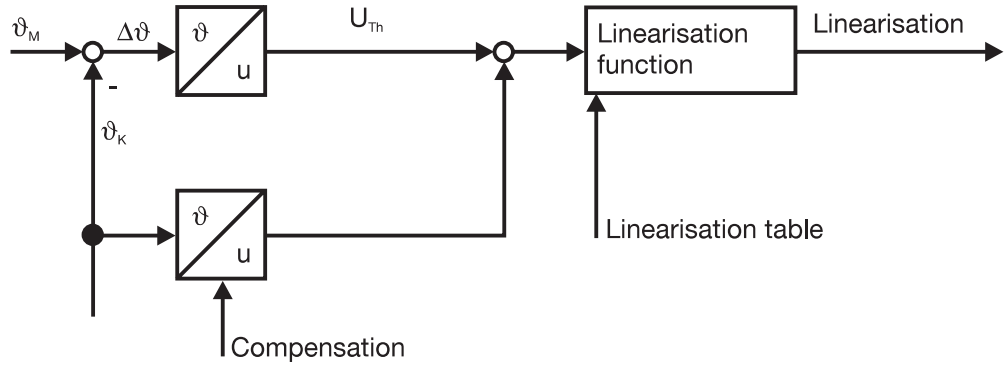

Measurement of the connector temperature and correction of the thermocouple voltage u_{Th}

- ϑ_M Measuring point temperature
- ϑ_K Connector temperature
- $\Delta\vartheta$ Differential temperature
- u_{Th} Thermocouple voltage

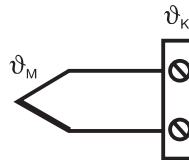

5 Parameter setting Type 704020/0-

5.4 Linearisation

This window shows the linearisation inputs and the replacement values 1 – 4.

Setup dialog

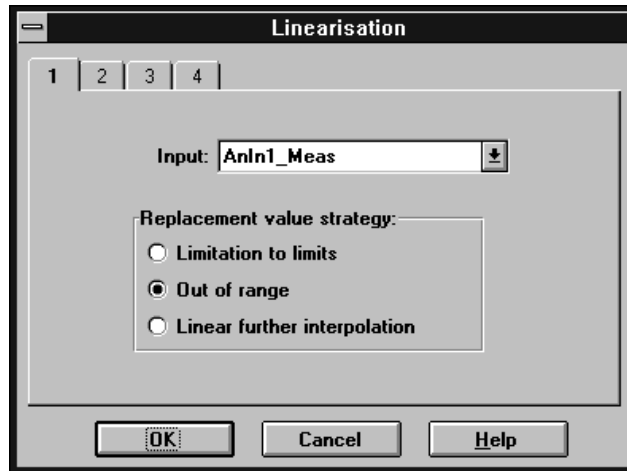

Parameters

Parameter	Selection/setting	Explanation
Linearisation x [Linearisn x]		
Input [SelInput]	AnInx_Meas [0] Maths [1] Ext_In x [2]	Input signal for linerarisation x ⇒ Chapter 4 “Network variables”
Replacement value strategy [RepVStrat]	Limitation to limits [Limit] Out of range [OutRnge] Linear further interpolation [Intpol]	see table “Replacement value strategy”
x = 1 – 4		

■ = factory setting [] = short name in the operating unit

Replacement value strategy

	Setting		
	OoR	Limits	Linear further
OoR	OoR	OoR	OoR
valid measurement	$y = f(x)$	$y = f(x)$	$y = f(x)$
$x > x_{max}$	OoR	$y = f(x_{max})$	extrapolate
$x < x_{min}$	OoR	$y = f(x_{min})$	extrapolate

5 Parameter setting Type 704020/0-

Function

The diagram shows the input and output signals of the function.

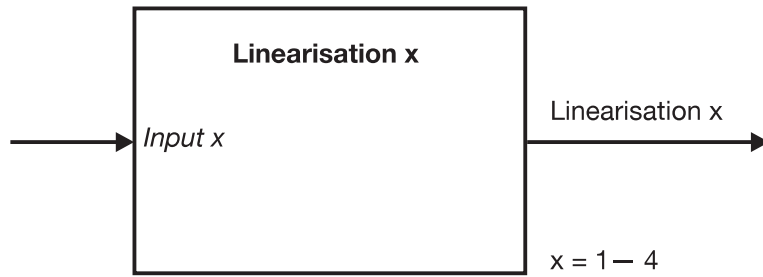

Block structure

The block structure shows the internal signal processing.

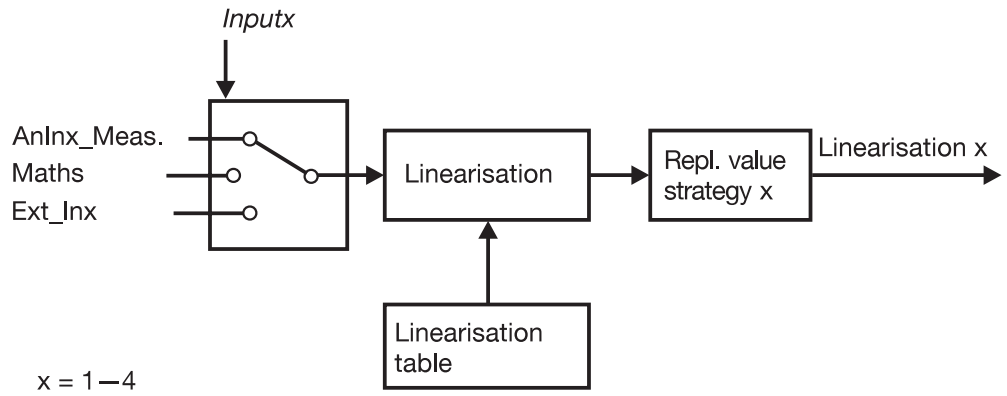

5 Parameter setting Type 704020/0-

5.5 Mathematics

The mathematics function links two input variables and outputs them as network variables.

Setup dialog

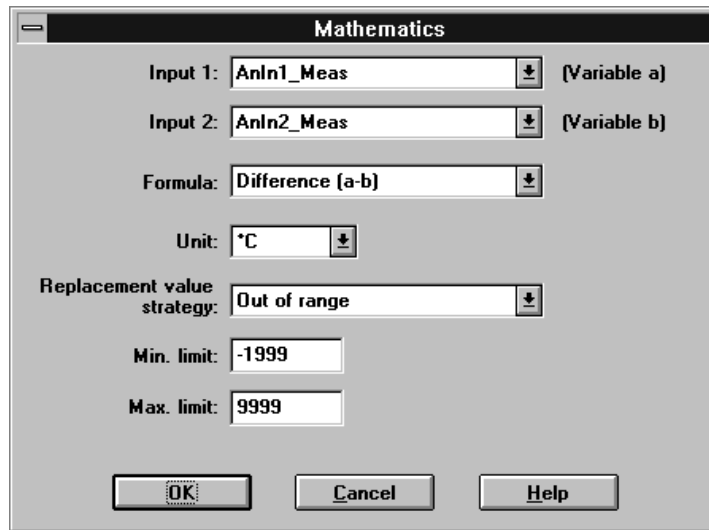

Parameters

Parameter	Selection/settings	Explanation
Input1 [SellInput1]	AnIn1_Meas [0]	Variable a
	AnIn2_Meas [1]	
	AnIn3_Meas [2]	
	AnIn4_Meas [3]	
	Ext_In1 [4]	
	Ext_In2 [5]	
	Ext_In3 [6]	
	Ext_In4 [7]	
	Linearisation 1 [8]	
	Linearisation 2 [9]	
	Linearisation 3 [10]	
	Linearisation 4 [11]	
Input 2 [SellInput2]	AnIn1_Meas [0]	Variable b
	AnIn2_Meas [1]	
	AnIn3_Meas [2]	
	AnIn4_Meas [3]	
	Ext_In1 [4]	
	Ext_In2 [5]	
	Ext_In3 [6]	
	Ext_In4 [7]	
	Linearisation 1 [8]	
	Linearisation 2 [9]	
	Linearisation 3 [10]	
	Linearisation 4 [11]	

■ = factory setting [] = short name in the operating unit

5 Parameter setting Type 704020/0-

Parameter	Selection/settings	Explanation
Formula [Formula]	Difference (a - b) [Diff]	Mathematical function
	Humidity (a: wet, b: dry) [Hum]	Measurement of humidity according to the psychrometric procedure:
	Ratio (a / b) [Ratio]	
	Square root (a) [Root]	WT=wet temperature
	Square (a) [Square]	DT = dry temperature
	Minimum (a , b) [Minimum]	
	Maximum (a , b) [Maximum]	
	Absolute value (a) [Absolut]	
	Sum (a + b) [Sum]	
	Product (a * b) [Product]	
Average (a , b) [Average]		
Unit [Unit]	°C	Unit of the calculated variable
	various	
Replacement value strategy [RepVStrat]	Limitation to limits [Limit]	Limitation to limits: Output signal is limited to limits or set to "Out of range" when there is an input signal error. Out of range: On overlimit the output signal is set to "Out of range" (invalid value).
	Out of Range [OutRnge]	
Min. limit [MinLimit]	-1999 to +9999	Min. result limitation
	-1999	
Max. limit [MaxLimit]	-1999 to +9999	Max. result limitation
	9999	

■ = factory setting [] = short name in the operating unit

Function

The diagram shows the input and output signals of the function.

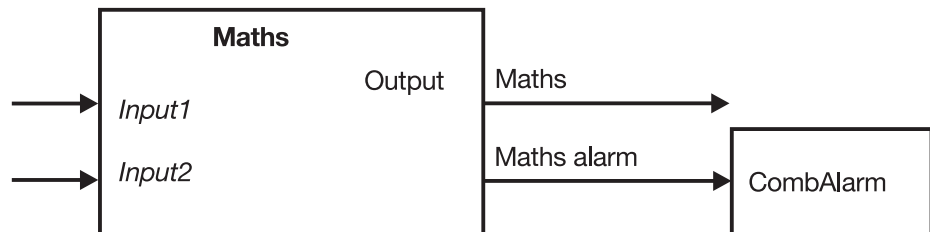

5 Parameter setting Type 704020/0-

Block structure The block structure shows the internal signal processing and the influence of the parameters.

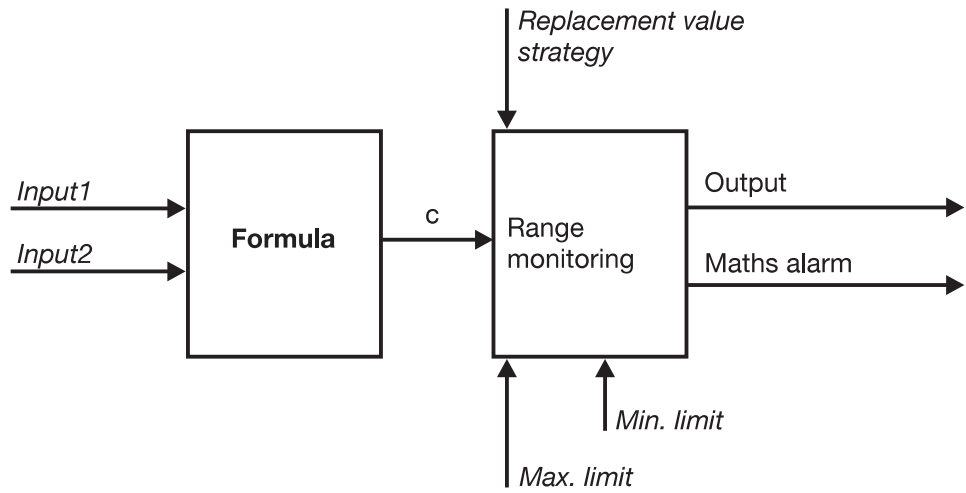

Error treatment

Input	OoR		Limits	
	Maths	Maths alarm	Maths	Maths alarm
a or b is OoR	OoR	1	OoR	1
c > max. limit	OoR	1	max. limit	1
c < min. limit	OoR	1	min. limit	1

5 Parameter setting Type 704020/0-

5.6 Limit comparator (LC)

Using a limit comparator, an input value or the difference of two input values can be monitored for exceeding/falling below a limit or range.

Setup dialog



Limit comparator

Input 1:
AnIn1_Meas

Input 2:
No function

Offset: 0.000
Gradient: 1.000

Function:
Comparator

Min. limit: 0.000
Max. limit: 0.000
Hysteresis (differential): 1.000

Time delay
Switch-on delay: 0.0 s
Switch-off delay: 0.0 s

Operation:
Operating input: Logic_Input
Function of operating input: No function
Characteristic for operating input: Direct

Replacement value: Off

Parameters

Parameter	Selection/settings	Explanation
Input 1 [Sellnp1]	No function [0]	Selection of signal input 1 if "no function" is set, then the value is "0"
	AnIn1_Meas [1]	
	AnIn2_Meas [2]	
	AnIn3_Meas [3]	
	AnIn4_Meas [4]	
	LC_In1 [5]	
	LC_In2 [6]	
	Linearisation 1 [7]	
	Linearisation 2 [8]	
	Linearisation 3 [9]	
	Linearisation 4 [10]	
Maths [11]		
Input 2 [Sellnp2]	No function [0]	Selection of signal input 2 if "no function" is set, then the value is "0".
	AnIn1_Meas [1]	
	AnIn2_Meas [2]	
	AnIn3_Meas [3]	
	AnIn4_Meas [4]	
	LC_In1 [5]	
	LC_In2 [6]	
	Linearisation 1 [7]	
	Linearisation 2 [8]	
	Linearisation 3 [9]	
	Linearisation 4 [10]	
Maths [11]		

■ = factory setting [] = short name in operating unit

5 Parameter setting Type 704020/0-

Parameter	Selection/settings	Explanation
Offset [Offset]	-1.999 – 9999	$E2^* = \text{gradient} \cdot \text{input 2} + \text{offset}$
	0.000	
Gradient [Gradient]	-1.999 – 9999	
	1.000	
Function [Function]	Comparator [Comp] Window discriminator [WDis] Comparator reversed [CompRev] Window discriminator reversed [WDisRev]	Defines the function of the limit comparator
Min. limit [MinLimit]	-1999 to +9999	Lower limit of window discriminator.
	0.000	
Max. limit [MaxLimit]	-1999 to +9999	Upper limit of window discriminator or limit of comparator
	0.000	
Hysteresis [Hysteresis]	0 – 9999	Switching differential
	1.000	
Time delay		
Switch-on delay [OnDelay]	0 – 9999sec	The LC signal is activated with time delay.
	0000sec	
Switch-off delay [OffDelay]	0 – 9999sec	The LC signal is inactivated with time delay.
	0000sec	
Operation		
Operating input [SelOpInp]	LC_LogIn [0]	Network variable
	LogicIn [1]	Logic input 1 hardware
Function of operating input [FunctOper]	No function [NoFunct]	No influence on signal
	Reset latch [ReLatch]	One positive switching edge of the LC output ("1") is held until it is reset via the operating input.
	Reset autodeletion [ReAuDel]	One negative switching edge of the LC output ("0") is held until it is reset via the operating input.
	Set Off [SetOff]	Sets the LC output to "0"
	Set On [SetOn]	Sets the LC output to "1"
Characteristic for operating input [CharOper]	Direct [Direct]	No influence on signal
	Reversed [Reversd]	Signal is reversed
Replacement value [ReplVal]	Off [Off]	Switching mode of the limit comparator with specific module states. This replacement value becomes active if, for example, due to a sensor break, an input indicates a value which can not be used by the LC.
	On [On]	

■ = factory setting [] = short name in operating unit

5 Parameter setting Type 704020/0-

Functions

The diagram shows the input and output signals of the function

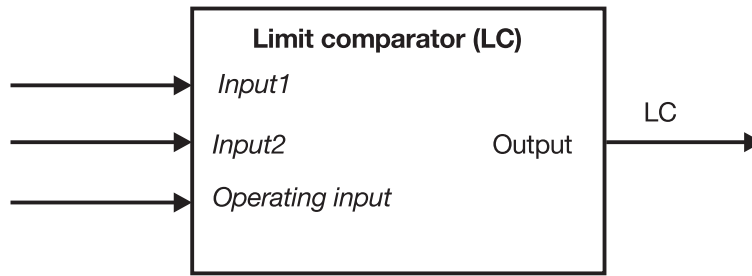

Block structure

The block structure shows the internal signal processing and the influence of the parameters.

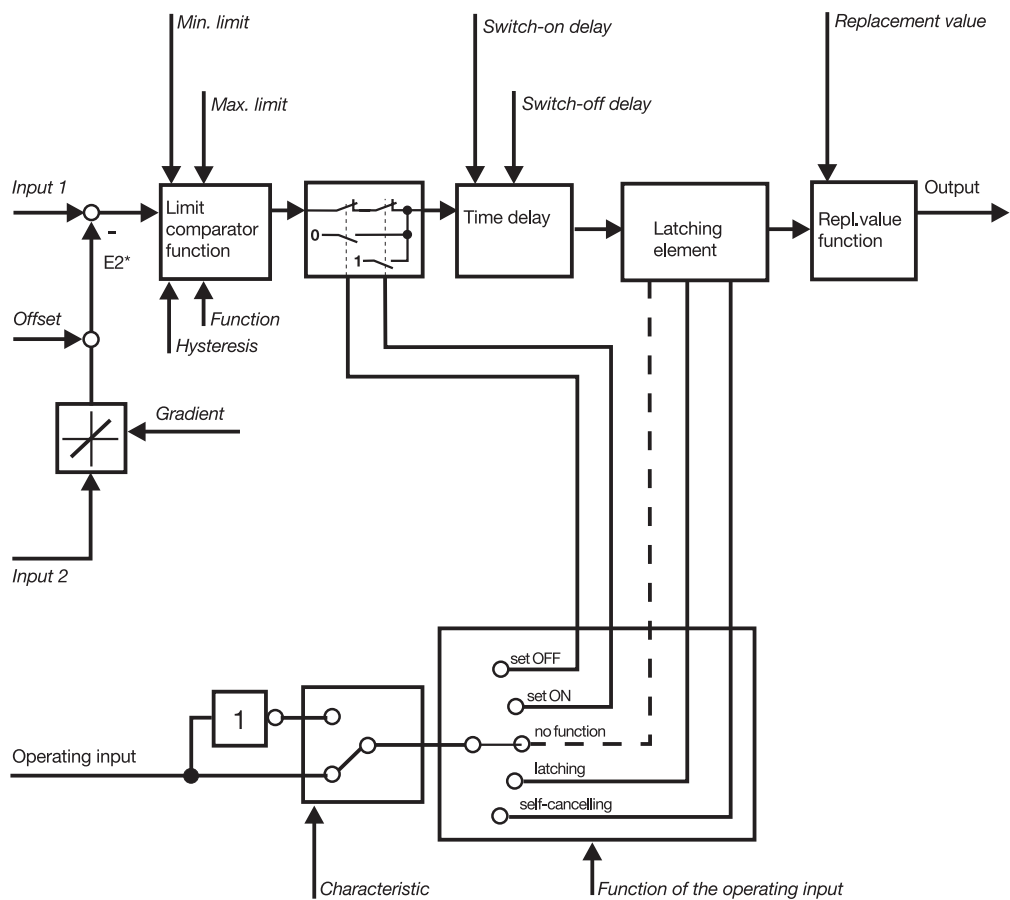

5 Parameter setting Type 704020/0-

Limit comparator functions

There is a choice of four different limit comparator functions.

Comparator

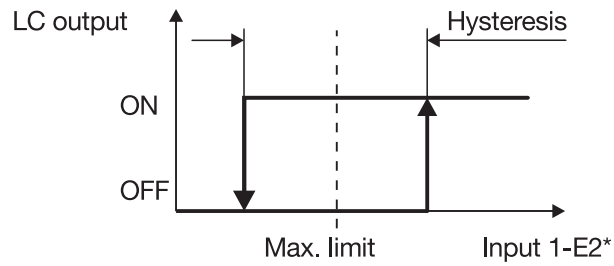

Comparator, reversed

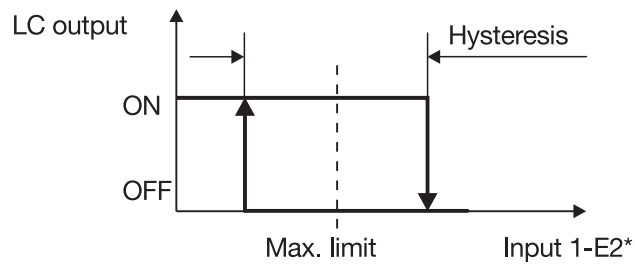

Window discriminator

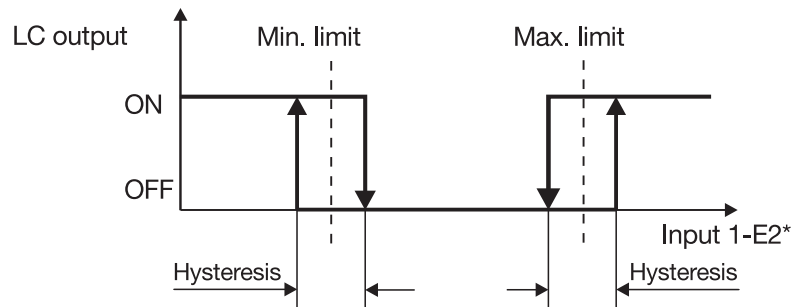

Window discriminator, reversed

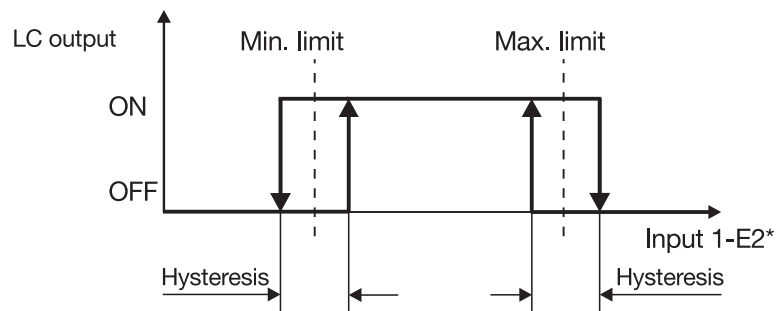

5 Parameter setting Type 704020/0-

Functions of the operating input

The operating input of the limit comparator can take on the following functions:

Set ON

Sets the output signal of the limit comparator function to "ON" (1).

Set OFF

Sets the output signal of the limit comparator function to "OFF" (0).

No function

Disables the latching element, i.e. the output signal of the time delay is looped through.

Latching

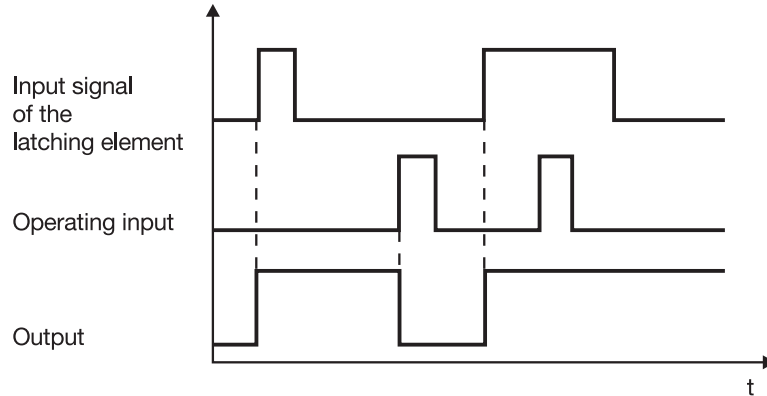

Self-cancellation

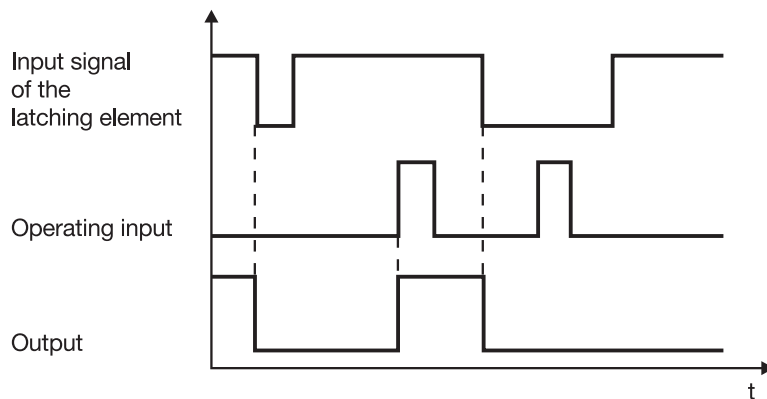

Switch-on/switch-off delay

The switch-on/switch-off delay influences the reaction to the switching edges of the output signal of the limit comparator function.

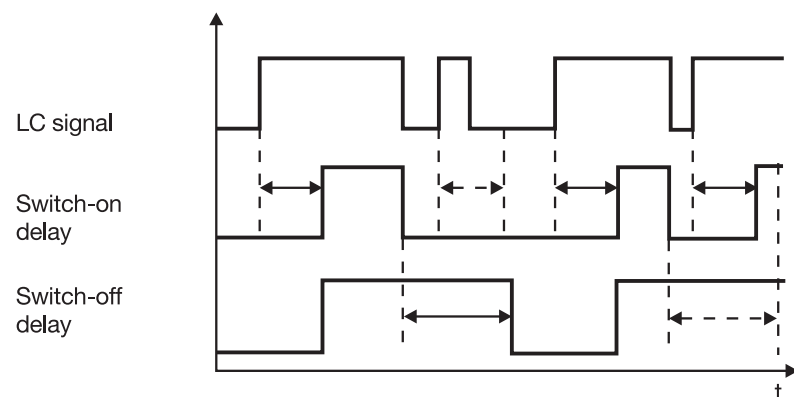

5 Parameter setting Type 704020/0-

5.7 Combination alarm

Various internal alarms of the module can be set here in such a way as to produce a combined alarm. The information is transmitted by the network variable “Combination alarm” and can be linked via JUMO mTRON -iTOOL.

⇒ Chapter 4 “Network variables”

Setup dialog

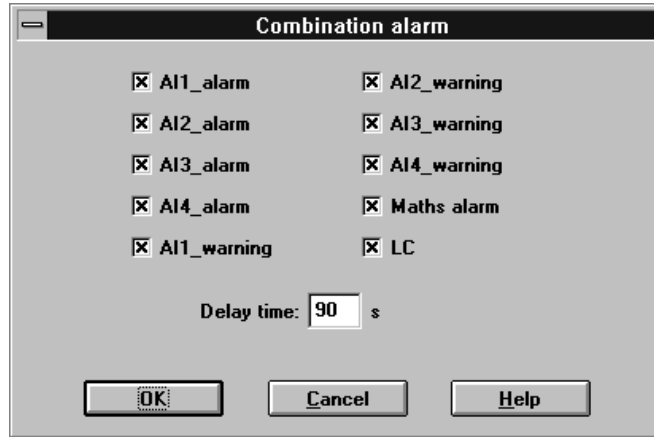

Parameters

Parameter	Selection / settings	Explanation
AnIn1_Alarm [SellInput1]	Triggger combination alarm [1] No combination alarm [0]	The alarms and warning alarms for the 4 measurement inputs, the maths processing and the limit comparator can produce a combination alarm. A combination alarm is output via the NV “Combination alarm”. ⇒ Section 4.2 “Output network-variables Type 704020/0-”
AnIn2_Alarm [SellInput2]	Trigger combination alarm [1] No combination alarm [0]	
AnIn3_Alarm [SellInput3]	Trigger combination alarm [1] No combination alarm [0]	
AnIn4_Alarm [SellInput4]	Trigger combination alarm [1] No combination alarm [0]	
AnIn1_Warn [SellInput5]	Trigger combination alarm [1] No combination alarm [0]	
AnIn2_Warn [SellInput6]	Trigger combination alarm [1] No combination alarm [0]	
AnIn3_Warn [SellInput7]	Trigger combination alarm [1] No combination alarm [0]	
AnIn4_Warn [SellInput8]	Trigger combination alarm [1] No combination alarm [0]	
Maths alarm [SellInput9]	Trigger combination alarm [1] No combination alarm [0]	
LC [SellInput10]	Trigger combination alarm [1] No combination alarm [0]	
Delay time [Delay1]	000 – 255 s 90 s	The combination alarm can be delayed by the adjustable time.

■ = factory setting

5 Parameter setting Type 704020/0-

Block structure

The block structure shows the internal signal processing and the influence of the parameters.

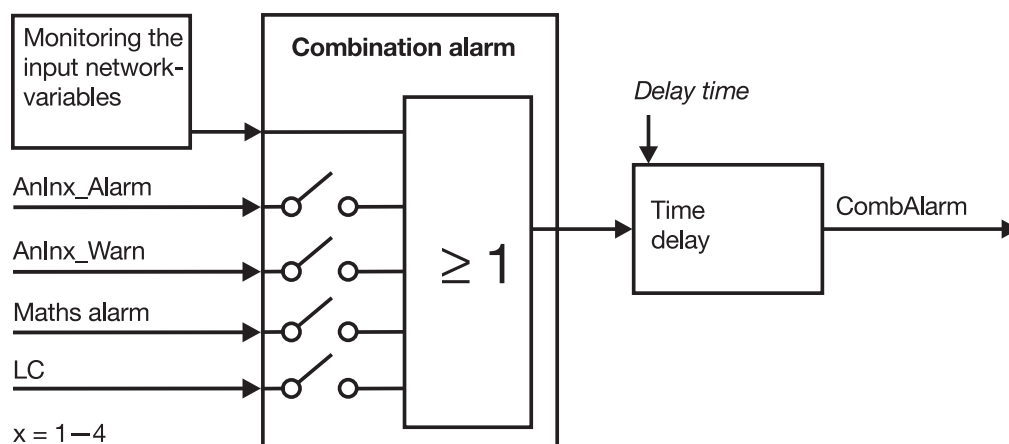

5 Parameter setting Type 704020/0-

6 Parameter setting Type 704020/1-

Basic menu



Module name
Name of the module

OK
for entering and storing all inputs

Setup dialog
The functions of the module are assigned to setup dialogs

Cancel
for aborting inputs. The data are not stored

Edit
for editing parameters in the marked setup dialog

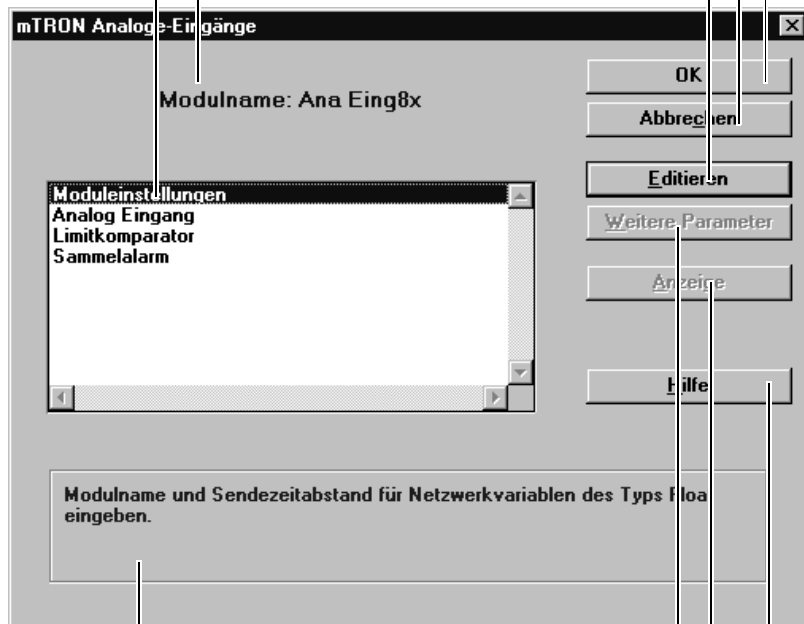

Additional parameters
Further settings can be made here when there are differences between the versions of module software and setup program

Display
Using this function, individual parameters can be removed from the operating unit (parameter level).

Info text
provides information on the setup dialog which is marked

Help
calls up the help text for the basic menu

6 Parameter setting Type 704020/1-

6.1 Module settings

A characteristic designation for the task of the module in the process is given here and the time interval for repeat transmissions of network variables determined.

Setup dialog

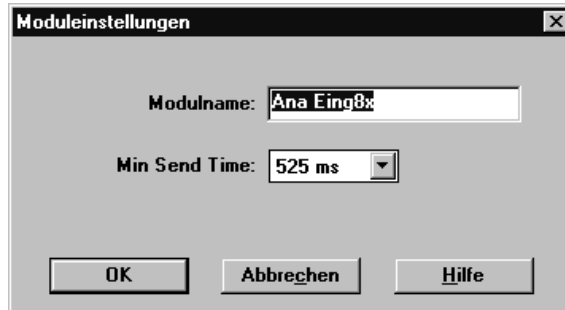

Parameters

Parameter	Selection/settings	Explanation
Module name [16 characters]	Analogue input	Name of the module (16 characters)
Min Send Time [MinSendTim]	n x 525ms max. time = 8.4s 525ms	Determines at which time intervals network variables of the "float value" type are sent via the network. The output network-variables "float value" type are sent without repetition at intervals of MinSendTime. The output network-variables of the "logic" type are instantly output with 2 repetitions at a status change (0 → 1, 1 → 0). If the status has not changed after 6sec, then there is an automatic output to the signal destinations via the network.

■ = factory setting [] = short name in the operating unit

6 Parameter setting Type 704020/1-

6.2 Analogue input

Eight measurement inputs measure thermovoltages, resistances and standard signals which are listed in the table.

Setup dialog



Parameters

Parameter	Selection/settings	Explanation
Meas. input [AnalogInpX]	X= 1 – 8	Selection of measurement input 1 – 8
Sensor [Sensor]	No sensor connected [NoSens] Pt1000 in 2-wire circuit 0–400 Ohm [3Pt100] 0–10V [0/10V] 2–10V [2/10V] 0–20mA [0/20mA] 4–20mA [4/20mA]	Defines the transducer to be connected to the specific analogue input.
Linearisation [Linearisn]	Linear [Linear] Pt100 [Pt 100] Type L Fe-Con [TypeL] Type J Fe-Con [TypeJ] Type K NiCr-Ni [TypeK] Type U Cu-Con [TypeU] Type T Cu-Con [TypeT] Type N NiCrSi-NiSi [TypeN] Type S Pt10Rh-Pt [TypeS] Type R Pt13Rh-Pt [TypeR] Type B Pt30Rh-Pt6Rh [TypeB]	Determines the linearisation function for the sensor.
Scaling start [ScalStart]	-1999 +9999 unit 0 unit	With standard signals or potentiometer: defines the start value (measured value) of the start value of the input signal range. With Pt100 (sensor: 0 – 400Ω/Pt100 linearisation) or thermocouple: makes an offset correction.
Scaling end [ScalEnd]	-1999 +9999 unit 100 unit	Defines the display value (measured value) of the end value of the standard signal or potentiometer range.
Unit [Unit]	°C various	Determines the physical unit of the measured value.

■ = factory setting [] = short name in the operating unit

6 Parameter setting Type 704020/1-

Parameter	Selection/settings	Explanation
Filter time constant [FiltTime]	0.0 – 40.0s 1.0s	The time constant which is used to filter the measured value with two digital PT1 filters. The value of the filter time constant is effective at all levels.
Min. limit [MinLimit]	-1999 – 9999 unit -50.0	If the measured value falls below the pre-set value, then an alarm is produced. ⇒ Section 4.4 “Output network-variables Type 704020/1-”
Max. limit [MaxLimit]	-1999 – 9999 unit +50.0	If the measured value goes above the pre-set value, then an alarm is produced. ⇒ Section 4.4 “Output network-variables Type 704020/1-”
Warning differential [WarnDiff]	-1999 – 9999 unit 0.0	The value of the input produces a warning alarm if: process value > max. limit - warning limit and also if: process value < min. limit + warning limit. ⇒ Section 4.4 “Output network-variables Type 704020/1-”

■ = factory setting [] = short name in the operating unit

Function

The block structure shows the input and output signals of the function.

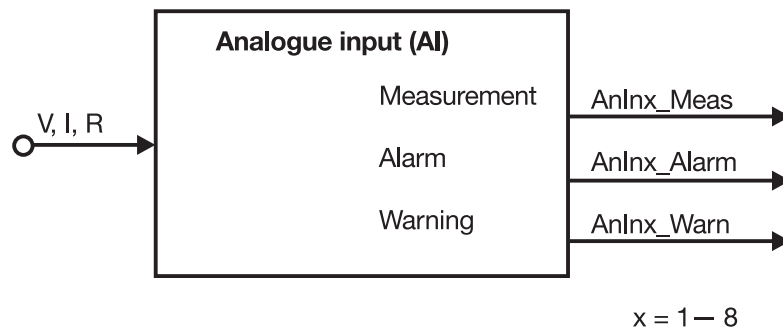

The analogue input module has 8 analogue inputs. The block diagrams below show the processing of the sensor signal, depending on the sensor type, until a measurement is produced.

6 Parameter setting Type 704020/1-

Block structure for resistance

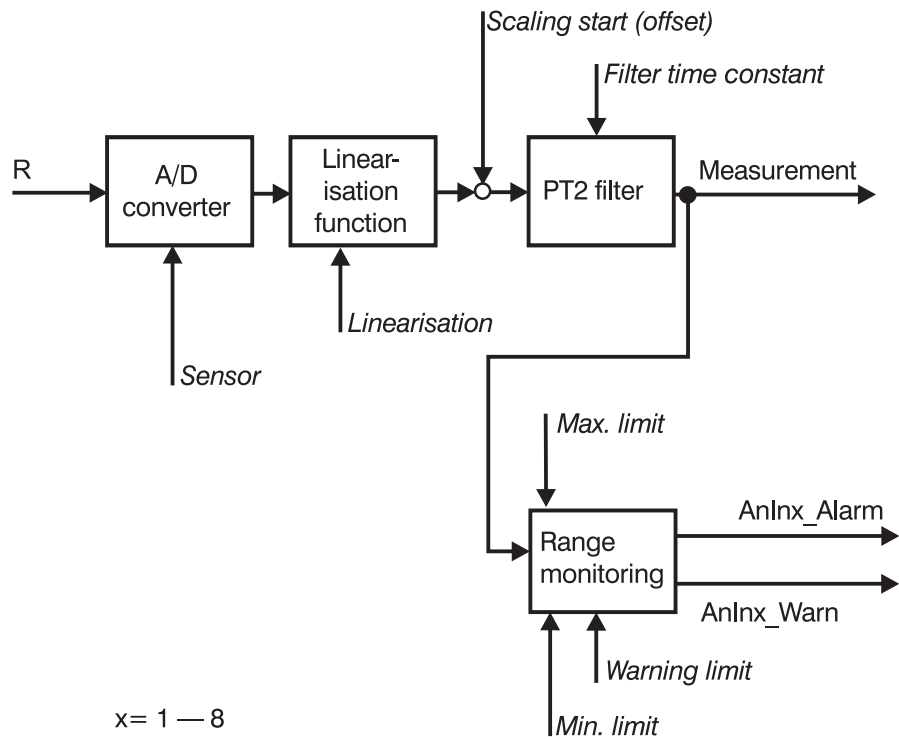

Block structure for standard signal

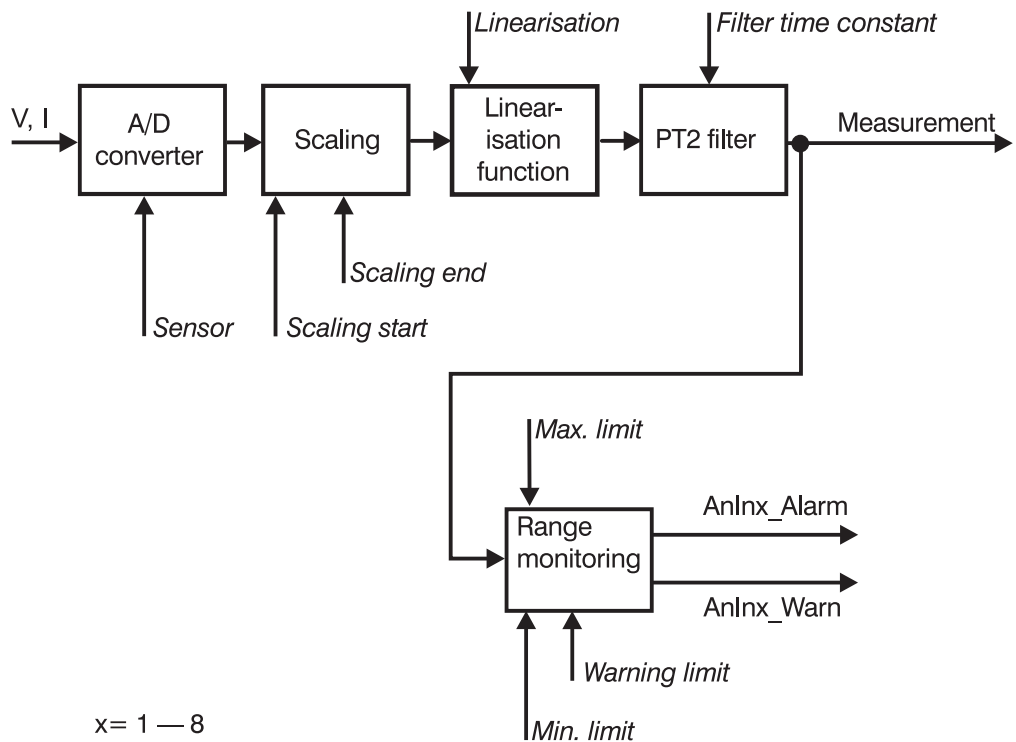

6 Parameter setting Type 704020/1-

Range monitoring

A range monitoring function is integrated into each of the analogue input functions. This function can be freely configured via parameter to monitor the measurement. The alarm signals (AnInx_Alarm, AnInx_Warn) are available as output network-variables and can be used to link up with other functions.

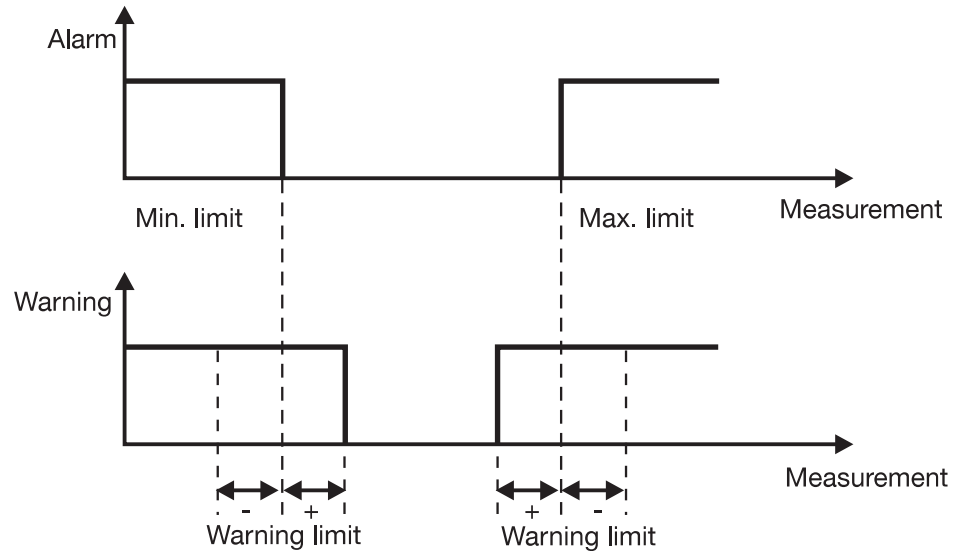

Range monitoring

On over/underrange of the selected current or voltage input range, the measurement itself is characterised as an invalid value by the “Out of Range” message, so that the operated functions can evaluate the invalid measurement. The table below shows on which sensor signals a sensor break is recognised and reported.

Transducer	Sensor break	Short circuit	Max. overrange
Resistance thermometer	X	X	0%
0 – 10V	–	–	+/-20%
2 – 10V	X	X	+/-20%
0 – 20mA	–	–	+/-20%
4 – 20mA	X	X	+/-20%

X = recognised

– = not recognised

Error treatment

In the event of a measurement error (e. g. sensor break),

- the alarm and warning are activated and
- the measurement is set to “Out of Range” (invalid value).

6 Parameter setting Type 704020/1-

6.3 Limit comparator (LC)

Using a limit comparator, an input value, or the difference between two input values, can be monitored for going above/below a limit or range.

Setup dialog



Limit comparator ✕

Input 1:

Input 2:

Offset:

Gradient:

Function:

Min. limit:

Max. limit:

Hysteresis (differential):

Time delay

Switch-on delay: s

Switch-off delay: s

Operation:

Operating input:

Function of operating input:

Characteristic for operating input:

Replacement value:

Parameters

Parameter	Selection/settings	Explanation
Input 1 [SellInp1]	No function [0]	Selection of signal input 1 if "no function" is set, then the value is "0"
	AnIn1_Meas [1]	
	AnIn2_Meas [2]	
	AnIn3_Meas [3]	
	AnIn4_Meas [4]	
	AnIn5_Meas [5]	
	AnIn6_Meas [6]	
	AnIn7_Meas [7]	
	AnIn8_Meas [8]	
	LC1_In1 [5]	
	LC1_In2 [6]	
	LC2_In1 [5]	
	LC2_In2 [6]	
	LC3_In1 [5]	
	LC3_In2 [6]	
	LC4_In1 [5]	
	LC4_In2 [6]	

■ = factory setting [] = short name in the operating unit

6 Parameter setting Type 704020/1-

Parameter	Selection/settings	Explanation
Input 2 [SelInp2]	No function [0]	Selection of signal input 2 if “no function” is set, then the value is “0”.
	AnIn1_Meas [1]	
	AnIn2_Meas [2]	
	AnIn3_Meas [3]	
	AnIn4_Meas [4]	
	AnIn5_Meas [5]	
	AnIn6_Meas [6]	
	AnIn7_Meas [7]	
	AnIn8_Meas [8]	
	LC1_In1 [9]	
	LC1_In2 [10]	
	LC2_In1 [11]	
	LC2_In2 [12]	
	LC3_In1 [13]	
	LC3_In2 [14]	
	LC4_In1 [15]	
LC4_In2 [16]		
Offset [Offset]	-1.999 – 9999	$E2 = \text{gradient} \cdot \text{input 2} + \text{offset}$
	0.000	
Gradient [Gradient]	-1.999 – 9999	
	1.000	
Function [Function]	Comparator [Comp] Window discriminator [WDis] Comparator reversed [CompRev] Window discriminator reversed [WDisRev]	Defines the function of the limit comparator.
Min. limit [MinLimit]	-1999 to +9999	Lower limit of the window discriminator.
	0.000	
Max. limit [MaxLimit]	-1999 to +9999	Upper limit of the window discriminator or limit for comparator
	0.000	
Hysteresis [Hysteresis]	0 – 9999	Switching differential
	1.000	
Time delay		
Switch-on delay [OnDelay]	0 – 9999s	The LC signal is activated with time delay.
	0000s	
Switch-off delay [OffDelay]	0 – 9999s	The LC signal is inactivated with time delay.
	0000s	
Operation		
Operating input [SelOpInp]	LC1_LogIn [0]	Network variable
	LC2_LogIn [1]	
	LC3_LogIn [2]	
	LC4_LogIn [3]	
	LogicIn1 [4]	
	LogicIn2 [5]	Logic input 2 hardware
Function of operating input [FuncOper]	No function [NoFunc]	No influence on signal
	Reset latch [ReLatch]	One positive switching edge of the LC output (“1”) is held until it is reset via the operating input.
	Reset autodeletion [ReAuDel]	One negative switching edge of the LC output (“0”) is held until it is reset via the operating input.
	Set Off [SetOff]	Sets the LC output to “0”
	Set On [SetOn]	Sets the LC output to “1”

■ = factory setting [] = short name in the operating unit

6 Parameter setting Type 704020/1-

Parameter	Selection/settings	Explanation
Characteristic for operating input [CharOper]	Direct [Direct]	No influence on signal
	Reversed [Reversd]	Signal is reversed
Replacement value [ReplVal]	Off [Off]	Switching mode of the limit comparator with specific module states. This replacement value becomes active if, for example, due to a sensor break, an input indicates a value which cannot be used by the LC.
	On [On]	

■ = factory setting [] = short name in the operating unit

Functions

The diagram shows the input and output signals of the function.

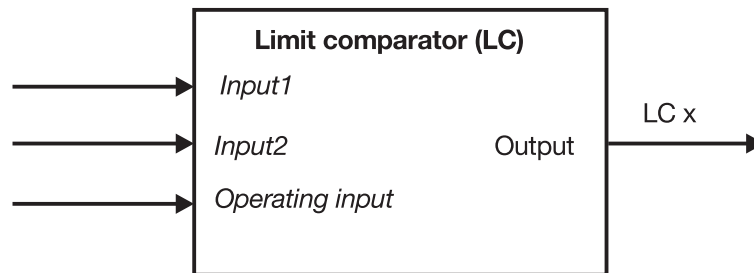

x = 1–4

Block structure

The block structure shows the internal signal processing and the influence of the parameters.

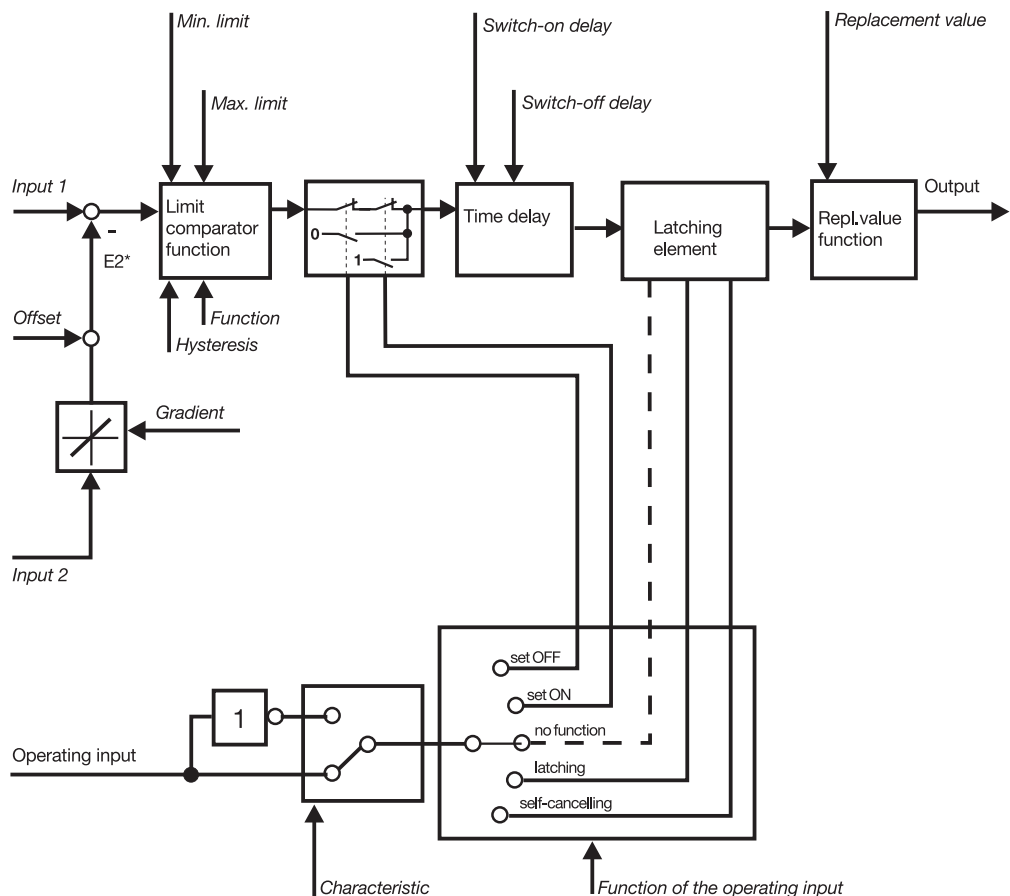

6 Parameter setting Type 704020/1-

Limit comparator functions

There is a choice of four different limit comparator functions.

Comparator

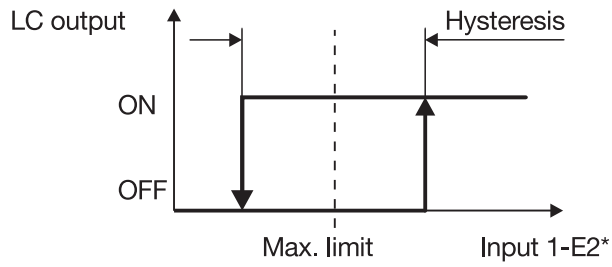

Comparator, reversed

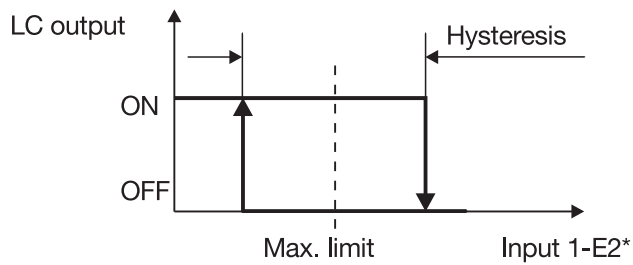

Window discriminator

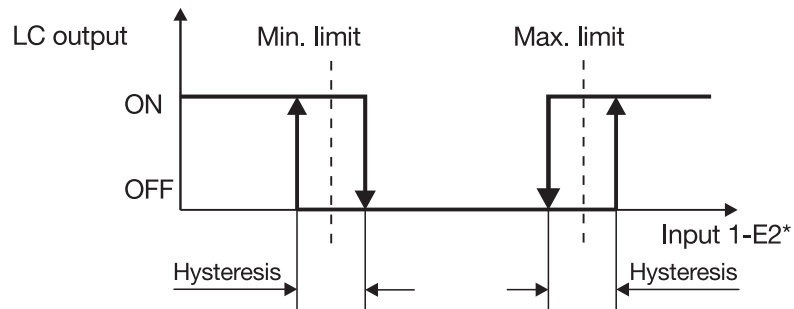

Window discriminator, reversed

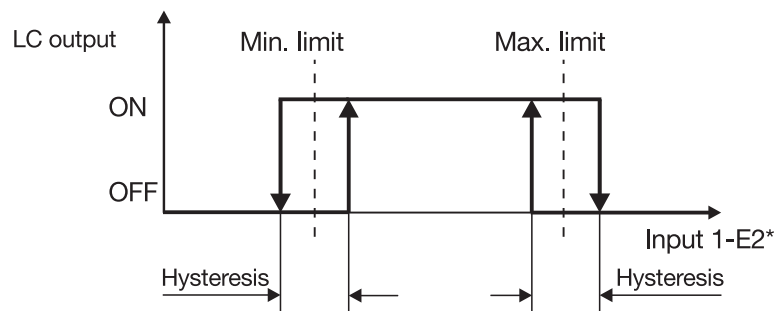

6 Parameter setting Type 704020/1-

Functions of the operating input

The operating input of the limit comparator can take on the following functions:

Set ON

Sets the output signal of the limit comparator function to “On” (1).

Set OFF

Sets the output signal of the limit comparator function to “Off” (0).

No function

Disables the latching element, i.e. the output signal of the time delay is looped through.

Latching

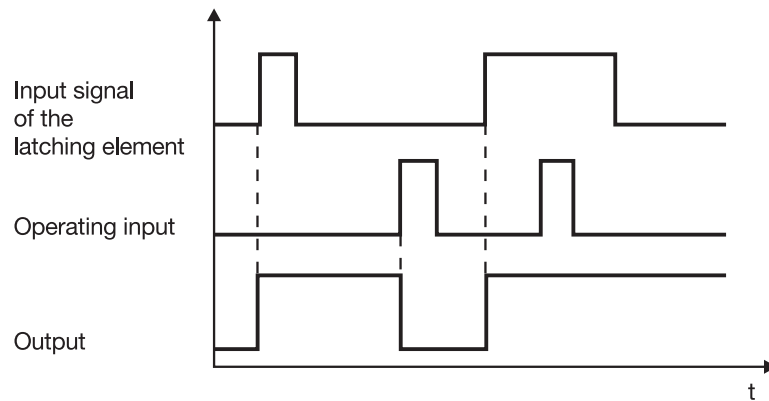

Self-cancellation

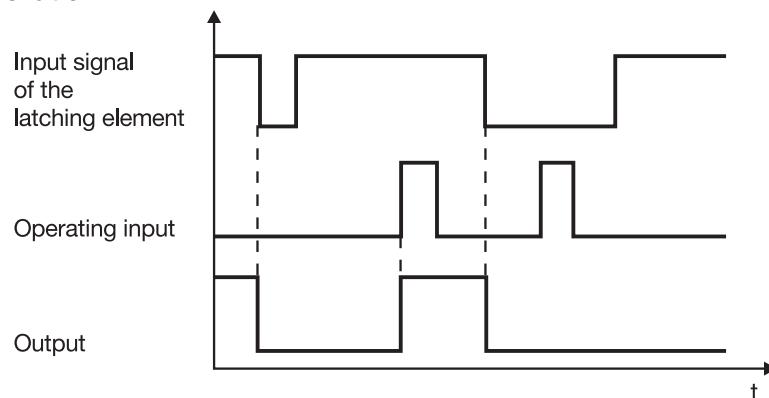

Switch-on/switch-off delay

The switch-on/switch-off delay influences the reaction to the switching edges of the output signal of the limit comparator function.

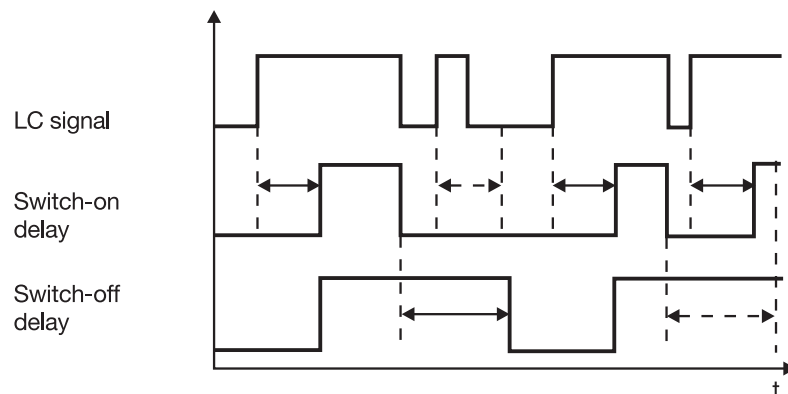

6 Parameter setting Type 704020/1-

6.4 Combination alarm

Various internal alarms of the module can be set here in such a way as to produce a combination alarm. The information is transmitted by the network variable “Combina- tion alarm” and can be linked via JUMO mTRON -iTOOL.

⇒ Chapter 4 “Network variables”

Setup dialog

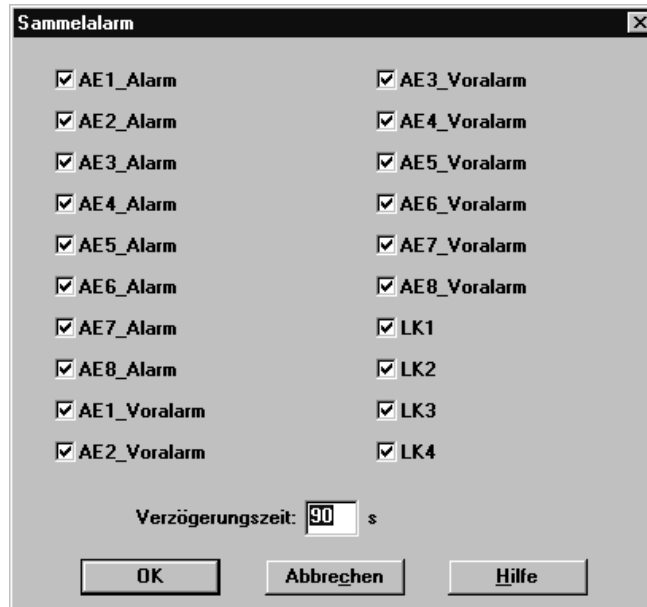

Parameters

Parameter	Selection / settings	Explanation	
AnIn1_Alarm	Trigger combination alarm No combination alarm	The alarms and warning alarms for the 8 measurement inputs, the mathematical processing and the limit comparator can produce a combination alarm. A combination alarm is output via the “Combina- tion alarm” NV. ⇒ Section 4.4 “Output network- variables Type 704020/1-”	
AnIn2_Alarm	Trigger combination alarm No combination alarm		
AnIn3_Alarm	Trigger combination alarm No combination alarm		
AnIn4_Alarm	Trigger combination alarm No combination alarm		
AnIn1_Warn	Trigger combination alarm No combination alarm		
AnIn2_Warn	Trigger combination alarm No combination alarm		
AnIn3_Warn	Trigger combination alarm No combination alarm		
AnIn4_Warn	Trigger combination alarm No combination alarm		
Maths alarm	Trigger combination alarm No combination alarm		
LC	Trigger combination alarm No combination alarm		
Delay time	000—255 s 90 s		The combination alarm can be delayed by an adjustable time.

■ = factory setting

6 Parameter setting Type 704020/1-

Block structure

The block structure shows the internal signal processing and the influence of the parameters.

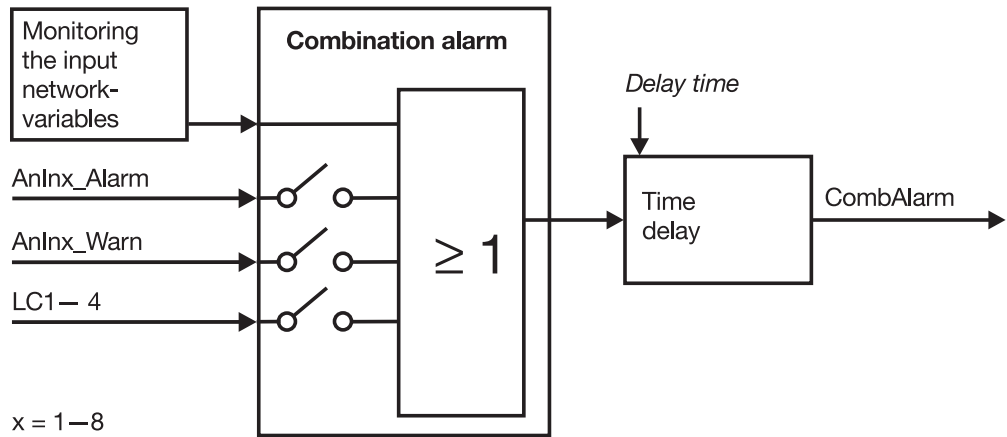

6 Parameter setting Type 704020/1-

7 Specific module conditions

7.1 Action after a power failure

The input network-variables are set to default values. The output network-variables remain inactive for approx. 15 sec.

7.2 Action on errors of communication

If the bound input network-variables are no longer being updated at regular intervals, then these variables are set to their default values and a combination alarm is produced.

If a function has been assigned to the variables, then this function outputs the corresponding replacement value.

7 Specific module conditions

A

action on errors of communication 5-51
analogue input 5-17, 5-39

B

basic menu 5-15, 5-37
block structure 5-9, 5-10

C

combination alarm 5-34, 5-48
comparator 5-32, 5-46
comparator, reversed 5-32, 5-46

D

displays and controls 5-7

F

functions of the operating input 5-33, 5-47
functions, overview of 5-9, 5-10

I

interface 5-8
introduction 5-3

K

keys 5-7

L

latching 5-33, 5-47
LEDs 5-7
limit comparator (LC) 5-29, 5-43
limit comparator functions 5-32, 5-46
linearisation 5-24
linearisation table 5-22

M

maths 5-26
module settings 5-16, 5-38

N

network variables 5-11
neuron-ID 5-5

O

ordering details 5-3

P

parameter setting, Type 704020/0 5-15

parameter setting, Type 704020/1 5-37

power failure 5-51

preface 5-3

R

range monitoring 5-20, 5-21, 5-42

S

self-cancellation 5-33, 5-47

set OFF 5-33, 5-47

set ON 5-33, 5-47

specific module conditions 5-51

switches 5-7

switch-on/switch-off delay 5-33, 5-47

T

Type 704020/0 5-3

Type 704020/1 5-5

W

window discriminator 5-32, 5-46

window discriminator, reversed 5-32, 5-46

Delivery address: Mackenrodtstraße 14,
36039 Fulda, Germany
Postal address: 36035 Fulda, Germany
Phone: +49 661 6003-0
Fax: +49 661 6003-607
E-mail: mail@jumo.net
Internet: www.jumo.net

JUMO House
Temple Bank, Riverway
Harlow, Essex CM 20 2TT, UK
Phone: +44 1279 635533
Fax: +44 1279 635262
E-mail: sales@jumo.co.uk
Internet: www.jumo.co.uk

885 Fox Chase, Suite 103
Coatesville PA 19320, USA
Phone: 610-380-8002
1-800-554-JUMO
Fax: 610-380-8009
E-mail: info@JumoUSA.com
Internet: www.JumoUSA.com



Analog input module



Brief description

The unit is a module of the JUMO mTRON control and automation system. The plastic housing measures 91 mm x 85.5 mm x 73.5 mm (W x H x D) and is mounted on a standard rail.

The module has four universal analog measurement inputs which can be monitored against adjustable limit values, one logic input, one counter input, one math function and a customized linearization which can be used for capturing and processing the measurement. There is also a selectable comparator function with switch-on and switch-off delay, as well as latching and gate circuit.

The analog input module incorporates a network connection for communication and data interchange between the modules. Numerous process and status signals can be exchanged with other units via the network.

A screened twisted pair is used as transmission line.

There is a setup interface for module parameter setting and configuration from a PC under the JUMO mTRON-iTOOL project design software.

The electrical connections are made through plug-in connectors with screw terminals.



Type 704020/...

Block structure

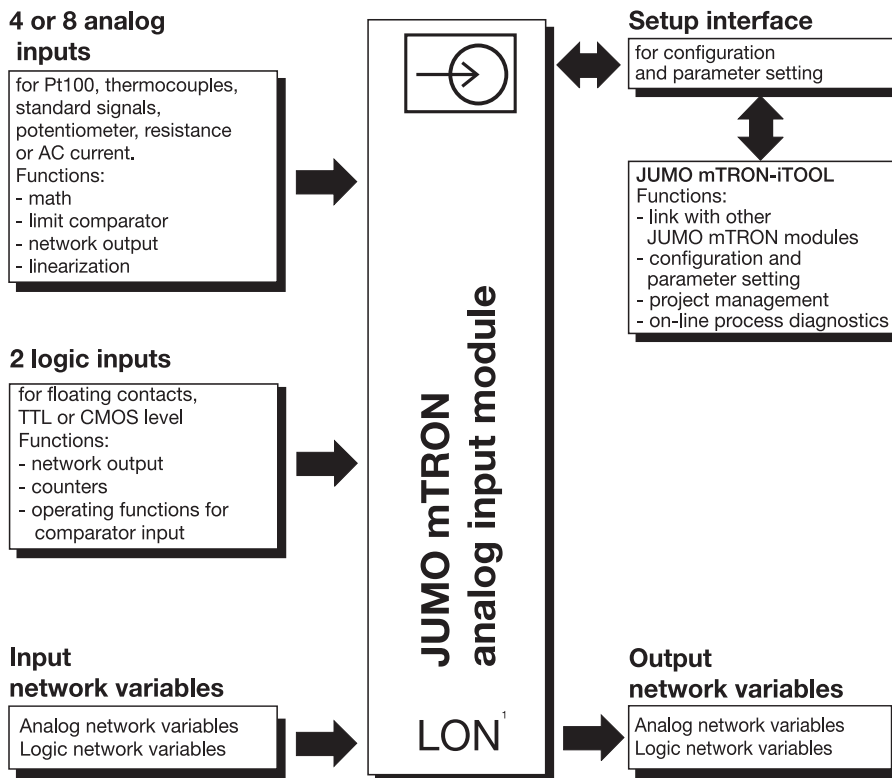

1. LON¹ = Local Operating Network.
Registered trademark of the ECHELON Corporation.

Features

- **Math functions**
Difference, humidity, ratio, square root, square, minimum, maximum, absolute value, sum, product, mean value
- **Limit comparator**
Comparator and window functions, direct or reversed, with switch-on and switch-off delay, also latching and gate circuit
- **Customized linearization**
Linearization function with up to 21 calibration points
- **Range monitoring**
The analog inputs are monitored against definable limit values
- **Setup interface**
For configuration and parameter setting the module is linked to a PC via a PC interface
- **Plug-&-Play-Function**
Problem-free replacement of modules without re-configuration

Technical data

Hardware inputs

Analog inputs

Measurement input

- resistance thermometer
- thermocouples
- standard signals (current/voltage)
- AC current (50/60Hz sinusoidal)
- resistance
- potentiometer

Sampling time

420 msec for all inputs

Functions

- network output
- math function
- customized linearization
- limit comparator

Logic input

activation: floating contact,
TTL or CMOS level

Functions:

- network output
- operating input
for the comparator function

Frequency input

activation: floating contact,
TTL or CMOS level
maximum counting rate: 15kHz

Note: The quoted measurement accuracy is only valid if all analog inputs have sensors connected.
Unused analog inputs must be shorted by a wire jumper.

Sensor	Measurement range ¹	Internal resistance/ voltage drop	Meas. circuit monitoring		Resolution	Measurement accuracy	
			Recognition of sensor break	Recognition of sensor short-circuit		Maximum measurement error ¹ at 23°C	Ambient temperature drift per 10°C
Pt100	-200 to +850°C (-200 to +850°C)		X	X	0.025°C	± 0.4°C	± 0.21°C
Fe-Con L	-200 to +900°C (-200 to +900°C)	47MΩ	X	-	0.05°C	± 1.8°C	± 0.9°C
Fe-Con J	-200 to +1200°C (-100 to +1200°C)	47MΩ	X	-	0.05°C	± 1.8°C	± 1.2°C
NiCr-Ni K	-200 to +1372°C (-100 to +1372°C)	47MΩ	X	-	0.07°C	± 1.9°C	± 1.4°C
Cu-Con U	-200 to +600°C (-100 to +600°C)	47MΩ	X	-	0.07°C	± 1.7°C	± 0.6°C
Cu-Con T	-200 to +400°C (-200 to +400°C)	47MΩ	X	-	0.07°C	± 1.6°C	± 0.4°C
NiCrSi-NiSi N	-100 to +1300°C (-100 to +1300°C)	47MΩ	X	-	0.07°C	± 2.3°C	± 1.3°C
Pt10Rh-Pt S	0 – 1768°C (100 – 1768°C)	47MΩ	X	-	0.3°C	± 3.4°C	± 1.7°C
Pt13Rh-Pt R	0 – 1768°C (100 – 1768°C)	47MΩ	X	-	0.25°C	± 3.4°C	± 1.7°C
Pt30Rh-Pt6Rh B	0 – 1820°C (400 – 1820°C)	47MΩ	X	-	0.3°C	± 4.4°C	± 1.4°C
Standard signals	-50 to +50mV	47MΩ	X	-	2.5μV	± 0.04mV	± 0.05mV
Standard signals	0 – 50mV	47MΩ	X	-	2.5μV	± 0.04mV	± 0.05mV
Standard signals	10 – 50mV	47MΩ	X	X	2.5μV	± 0.04mV	± 0.05mV
Standard signals	-10 to +10V	2MΩ	-	-	500μV	± 8mV	± 15mV
Standard signals	0 – 10V	2MΩ	-	-	500μV	± 8mV	± 15mV
Standard signals	2 – 10V	2MΩ	X	X	500μV	± 8mV	± 15mV
Standard signals	-1 to +1V	2MΩ	-	-	50μV	± 0.8mV	± 1.5mV
Standard signals	0 – 1V	2MΩ	-	-	50μV	± 0.8mV	± 1.5mV
Standard signals	0.2 – 1V	2MΩ	X	X	50μV	± 0.8 mV	± 1.5mV
Standard signals	-20 to +20mA	less than 1 V	-	-	1μA	± 15μA	± 30μA
Standard signals	0 – 20mA	less than 1V	-	-	1μA	± 15μA	± 30μA
Standard signals	4 – 20mA	less than 1V	X	X	1μA	± 16μA	± 30μA
AC current	0 – 50mA	less than 1V	-	-	5μA	1mA	± 100μA
Resistance	0 – 400Ω		X	X	0.01 Ω	± 0.15Ω	± 0.1Ω
Potentiometer	0.1 – 10KΩ		X (slider)	-	0.01 %	0.25 %	0.1 %

X: recognized – : not recognized

1. The accuracy given refers to the ranges given in brackets. With thermocouples, the accuracy is obtained only in the specified operating position and after an operating time of at least 1 hour.

Displays and controls

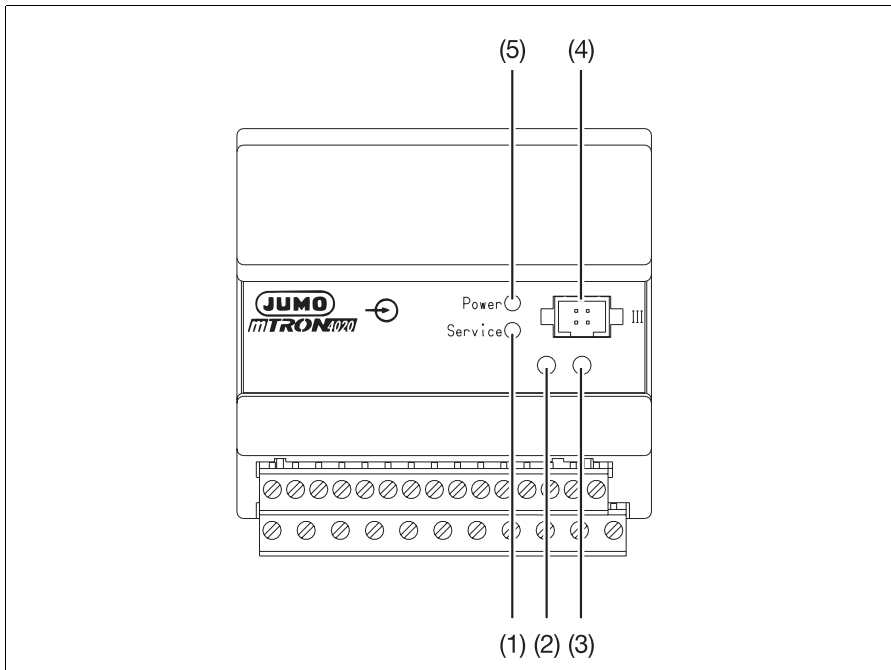

(1)	Service LED, red - lights up on operating fault - flashes when the mechanical connection to the module from JUMO mTRON- iTOOL or the operating unit is being checked by a test signal ("wink")	(4)	Setup interface for the PC interface line which links the module to the PC
(2)	Switch for the termination resistance of the LON network	(5)	Power LED, green lights up when the supply is switched on
(3)	Installation key the module reports to the JUMO mTRON-iTOOL project design software or the operating unit		

Input network variables

Analog network variables

Functions:

- math function
- customized linearization
- limit comparator

Logic network variable

Function:

- operating input for the comparator function

Output network variables

Analog network variables

Output cycle: 420 msec — 8.4sec, adjustable

Functions:

- measurement analog input 1 — 4 (8)
- output for math
- output for linearization 1 — 4 (8)

Frequency input

Output cycle: 0.8388608sec

Function:

- output of the pulses counted at fixed intervals

Logic network variables

Output cycle: event-controlled but at least every 14sec

Functions:

- limit comparator output
- output of the logic input
- monitoring of the analog inputs
- monitoring of the network inputs (combined alarm)

General data

Environmental conditions to EN 61 010

Operating and ambient temperature: 0 — 55°C

Permitted storage temperature: -40 to +70°C

Relative humidity: rH 80 % max.

Pollution degree 2

Oversvoltage category 2

Housing

Material: plastic, self-extinguishing

Flammability Class: UL 94 VO

Protection: IP20 (to EN 60 529)

Mounting: on standard rail

Supply

110 — 240V AC +10/-15%, 48 — 63Hz, or 20 — 53V AC/DC, 48 — 63Hz

Power consumption: 5 VA max.

Network (LON interface)

Topology: free topology FTT-10A (ring, star, line or mixed structure)

Baud rate: 78 kbaud

Max. lead length (depending on lead type):

line: 2700m

star: 500m

ring: 500m

mixed: 500m

Max. number of modules: 64

Operation and project design

Operation, parameter setting and configuration of JUMO mTRON modules can be carried out from the JUMO mTRON operating unit.

The JUMO mTRON-iTOOL project design software permits convenient design and start-up of a JUMO mTRON system.

The projects can be archived and documented. Individual modules are linked via LON by assigning network variable (NV) names.

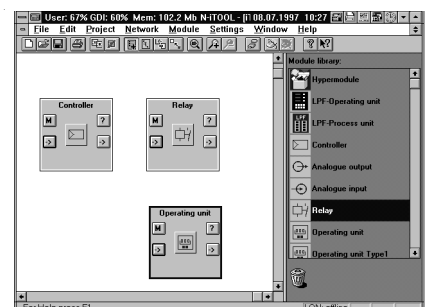

Connection diagram for Type 704020/0-

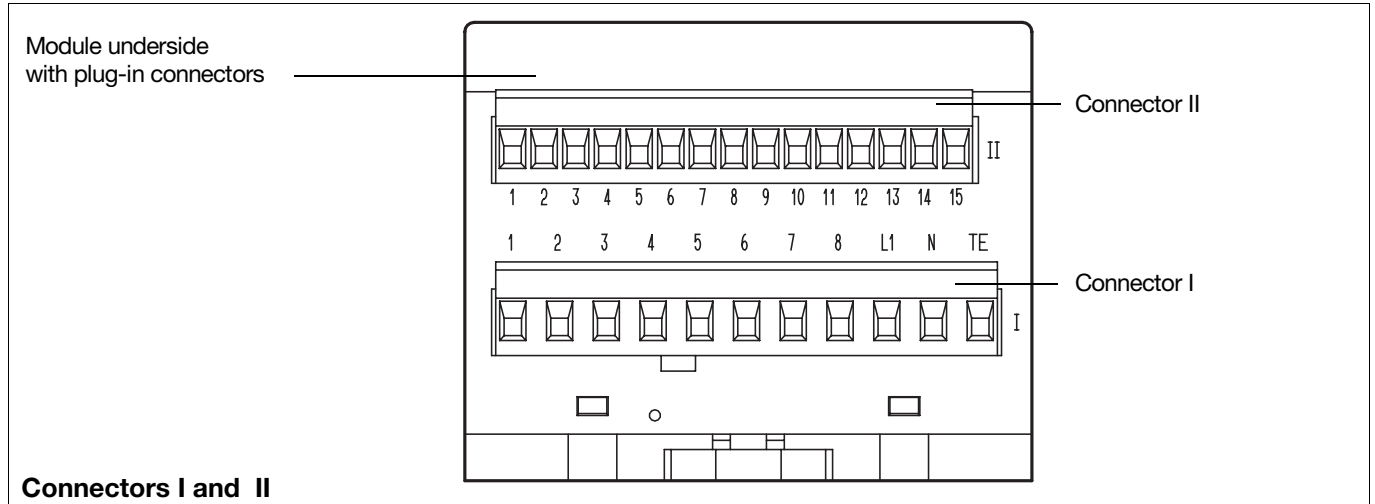

Connectors I and II

Connection for	Terminals				Notes	Diagram
Analog inputs	Input 1	Input 2	Input 3	Input 4		
Thermocouple	I_4+ I_3-	I_8+ I_7-	II_8+ II_7-	II_12+ II_11-		
Resistance thermometer in 3-wire circuit resistance 0 — 400Ω with 3-wire connection	I_4 I_2 I_3	I_8 I_6 I_7	II_8 II_6 II_7	II_12 II_10 II_11		
Resistance thermometer in 2-wire circuit resistance 0 — 400Ω with 3-wire connection	I_2 I_4 I_3	I_6 I_8 I_7	II_6 II_8 II_7	II_10 II_12 II_11	$R_A = R_{lead}$	
Potentiometer	I_2 I_4 I_3	I_6 I_8 I_7	II_6 II_8 II_7	II_10 II_12 II_11	E = end S = slider A = start	
Voltage 0 — 10mV 10 — 50mV -50 to +50mV	I_4+ I_3-	I_8+ I_7-	II_8+ II_7-	II_12+ II_11-		
Voltage input 0 — 1V / 0.2 — 1V -1 to +1V 0 — 10V / 2 — 10V -10 to +10V	I_1+ I_3-	I_5+ I_7-	II_5+ II_7-	II_9+ II_11-		
Current 0 — 20mA 4 — 20mA	I_4+ I_3-	I_8+ I_7-	II_8+ II_7-	II_12+ II_11-		

Connection for	Terminals				Notes	Diagram
	Input 1	Input 2	Input 3	Input 4		
Analog inputs			II_7 II_8	II_11 II_12		
Logic input floating contact TTL or CMOS level	II_1 II_2					
Frequency input floating contact TTL or CMOS level	II_1 II_3					
LON interface	II_13 = TE				screen	
	II_14 = Net_A II_15 = Net_B				any polarity	
Technical earth	II_13					
Supply as label	AC		DC			
	I_L1 line I_N neutral I_TE technical earth		I_L1 } any I_N } polarity I_TE technical earth			

Dimensions

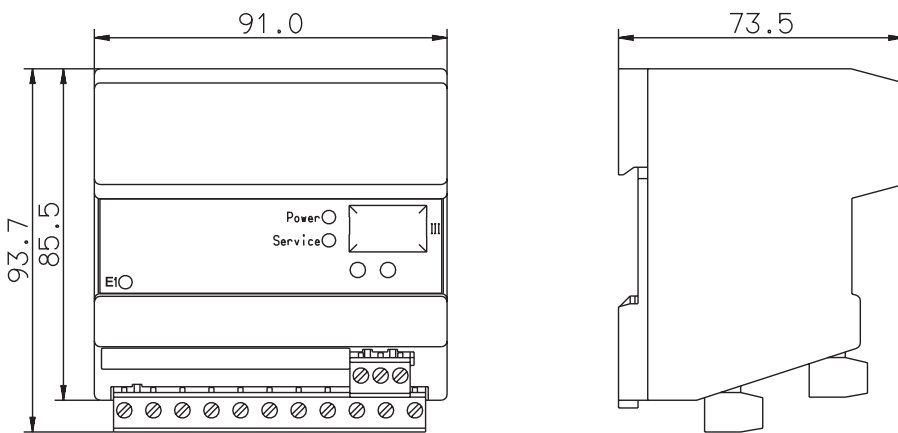

Connection diagram for Type 704020/1-

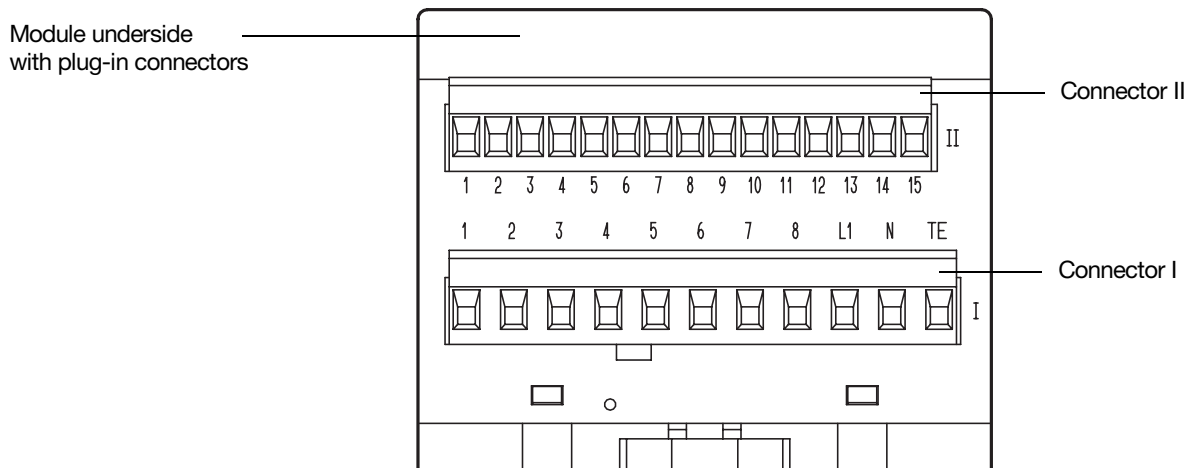

Connection for	Terminals								Diagram
	1	2	3	4	5	6	7	8	
Analog inputs	I_1	I_3	I_5	I_7	II_5	II_7	II_9	II_11	
Resistance thermometer Pt100 and Pt1000 in 2-wire circuit	I_2	I_4	I_6	I_8	II_6	II_8	II_10	II_12	
Voltage 0 – 10V 2 – 10V, see pages 7-8	I_1+	I_3+	I_5+	I_7+	II_5+	II_7+	II_9+	II_11+	
Current 0 – 20mA 4 – 20mA, see pages 7-8	I_2-	I_4-	I_6-	I_8-	II_6-	II_8-	II_10-	II_12-	
Logic input 1 floating contact TTL or CMOS level	II_1	II_2							
Logic input 2 floating contact TTL or CMOS level	II_1	II_3							

Ordering details

704020/0- -

(1) Analog inputs

Standard version 888

Measurement input	Inputs			
	1	2	3	4
Pt100 resistance thermometer	X	X	X	X
Thermocouples Fe-Con L Fe-Con J NiCr-Ni K Cu-Con U Cu-Con T NiCrSi-NiSi N Pt10Rh-Pt S Pt13Rh-Pt R Pt30Rh-Pt6Rh B				
Standard signals 0 – 50 mV 10 – 50 mV -50 to +50 mV 0 – 1 V 0.2 – 1 V -1 to +1 V 0 – 10 V 2 – 10 V -10 to +10 V 0 – 20 mA 4 – 20 mA				
AC current 0 – 50mA				
Resistance 0 – 400Ω				
Potentiometer 0.1 – 10KΩ				

Special version 999

Factory-configured to customer specification. Please specify inputs in plain language, see table.

(2) Supply

Type	Code
110 – 240V AC +10/-15%, 48 – 63Hz	23
20 – 53V AC/DC, 48 – 63Hz	22

X = factory-set, freely programmable

Ordering details

704020/1- -

(1) Analog inputs

Standard version 888

Measurement input	Inputs 1–8
Pt100 resistance thermometer in 2-wire circuit	179
Pt1000 resistance thermometer in 2-wire circuit	180
Standard voltage signals: (switchable via JUMO mTRON-iTOOL) 0 – 10 V 2 – 10 V	181
Standard current signals: (switchable via JUMO mTRON-iTOOL) 0 – 20 mA 4 – 20 mA	182

Special version 999

(2) Supply

Type	Code
110 – 240V AC +10/-15%, 48 – 63Hz	23
20 – 53V AC/DC, 48 – 63Hz	22

Standard accessory

1 Installation instructions B 70.4020.4

Accessories

PC interface

with TTL/RS232C converter

for connecting the module to a PC; length 2m.

Sales No. 70/00301315

Project design software

JUMO mTRON-iTOOL

Using the JUMO mTRON-iTOOL project design software, the modules can be designed graphically on the PC. The user is able to link modules of the JUMO mTRON family and to configure the application-specific parameters.

System Manual JUMO mTRON

Documentation of configuration, parameter setting and installation of the modules.

Sales No. 70/00334336

JUMO mTRON modules

Controller module

Data Sheet 70.4010

Relay module

Data Sheet 70.4015

Analog input module

Data Sheet 70.4020

Analog output module

Data Sheet 70.4025

Logic module

Data Sheet 70.4030

Operating unit

Data Sheet 70.4035

Communication module

Data Sheet 70.4040

Project design software

JUMO mTRON-iTOOL

Data Sheet 70.4090