

JUMO DICON S

Universal Compact Controller

for industrial and process control

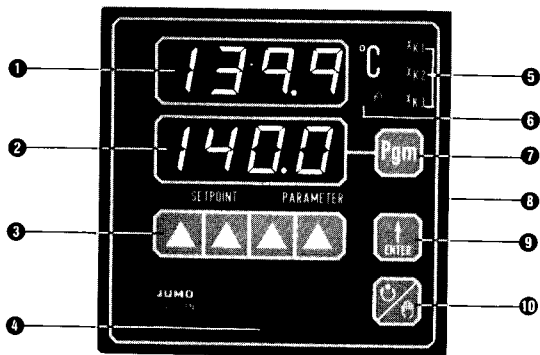

Indications and controls

- 1 Numerical display
4-digit LED display for process
- 2 Alphanumeric display
4-character text display for comments on numerical display or for indicating further process variables
- 3 Increment keys
with 4 keys any position in the display can be changed immediately
- 4 Fixing screws for the controller chassis
- 5 LEDs for switched outputs
- 6 LED for manual operation
- 7 Programming key for parameter selection
- 8 DIN housing for flush mounting; bezel 96 x 96 mm
- 9 Enter key for entering the inputs
- 10 Auto/manual key

D 97.550.1

9.88/V

Brief Operating Instructions

OPERATION

Programming planes and blocks

For clearer identification of the large number of possible programming inputs the controller data are arranged in three distinct planes: operating plane, parameter plane and configuration plane.

Operating plane

The two displays show setpoint and actual value. The setpoint can be changed here. It is also possible to change over to manual operation. With appropriate configuration it is possible to produce other displays, such as heater current, stroke, return flow temperature, parameter name etc.

Parameter plane

In this plane the controller can be matched to the process. The individual parameters are displayed sequentially as value and symbol. Only those parameters are indicated which correspond to the particular controller model (see Table of parameters).

Configuration plane

This plane serves to adapt the controller to the particular application. The control is out of action. It is seldom necessary to change the factory settings, e. g. when the control application or the input circuit is altered (see Operation Instructions D 97.550).

In addition it offers a choice whether the controller on switching on operates with the factory settings in the configuration plane or whether the data entered by the user are used.

NOTE:

The three planes can be blocked with internal switches (see Operating Instructions D 97.550).

Standard setting

Block	Controller data
Operating plane:	
Access possible	Adjustment by user
Parameter plane:	
Access possible	Set at the factory; user adjustment possible
Configuration plane:	
Blocked at the factory	Set at the factory; user adjustment possible

OPERATION

Identification of display

In the standard arrangement the process is shown on the upper display and the setpoint on the other display. For different displays see ordering details or configuration data.

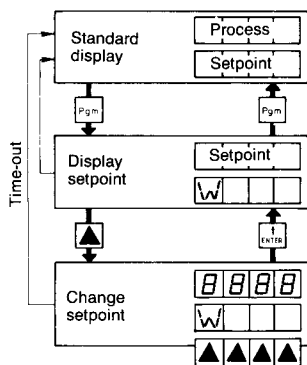

Display and change setpoint

- After pressing the "Pgm" key the top display shows the setpoint and the bottom display the parameter name W.
- Change the setpoint with the "increment" keys (W flashes).
- The changed setpoint is entered with "ENTER".
- Further parameters can be displayed with "Pgm" or the controller returns to the standard display¹⁾.

NOTE:

If there is no input for 30 seconds the controller returns automatically to the standard display (time-out).

¹⁾ Further parameters are contained in the sub-register UV08 of the configuration table; these can be entered into the operating plane (see Operating Instructions D 97.550).

OPERATION

Manual operation

The controller is supplied with the manual operation blocked. This plane becomes accessible with the internal switch S 301.3.

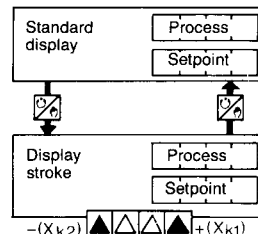

Modulating controller

- Open the control loop with "auto/manual" key.
- Change the stroke with the outer increment keys within the range 0–100%.
- Return to automatic operation (standard display) with "auto/manual".

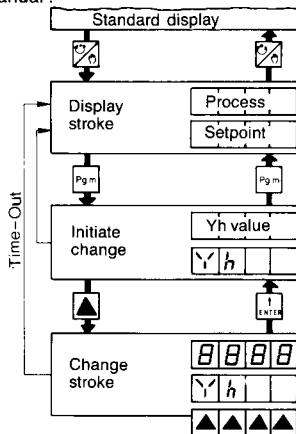

Single-setpoint, double-setpoint and proportional controller

- Open the control loop with "auto/manual" key.
- Initiate change with "Pgm".
- Change the stroke with the increment keys 0–100% (–100/0/+100% on double-setpoint controller); enter with "ENTER".
- Return to automatic operation (standard display) with "auto/manual".

CONFIGURATION PLANE

Display configuration

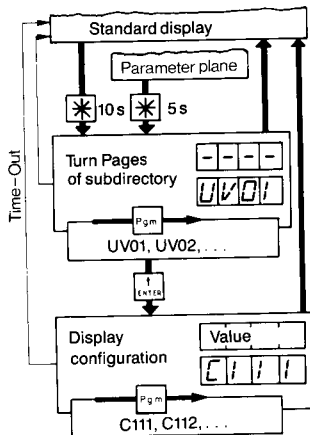

The configuration plane can be accessed both from the operating plane and from the parameter plane. The configuration data are divided into nine sub-directories UV01–09. The step "Turn pages of sub-directory" permits rapid location of the configuration code.

Changing the configuration data

Access to the configuration plane is only possible after the plane has been unblocked and the data transfer of the factory-set parameters has been switched off. Please use the Operating Instructions D 97.550.

Self-optimisation (optional)

- Initiate optimisation
- Start self-optimisation with the two outer increment keys.
- Condition: difference between process and setpoint must be greater than 10°C.
- The word "TUNE" is flashing in the alphanumerical display
- After the calculation process the two displays show again process and setpoint.

PARAMETER PLANE

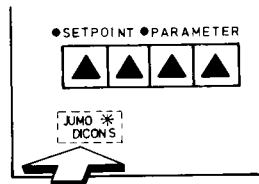

Access to the parameter plane is obtained by pressing the "DICON" key (*) for 5 seconds. The key is located at the bottom on the left-hand side of the controller front panel (not visible).

Display and change parameters

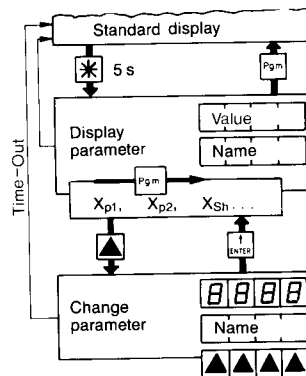

- Call up parameter according to Parameter Table with "Pgm".
- Change parameter with "Increment" keys.
- Enter parameter with "ENTER".
- Call up further parameters with "Pgm". After the last parameter the controller returns automatically to the standard display.

NOTE:

In case of incorrect inputs the top display shows the minimum or maximum value permitted.

PARAMETER TABLE

Single-setpoint controller with two limit comparators

Symbol	Parameter	Feedback action				Adjustment range	Factory setting
		none	PD	PID	PD/PID		
XP1	Proportional band	—	●	●	●	$X_p = 0 - 9999$ digit	0 digit
XD1	Differential	●	—	—	—	$X_d = 1 - 9999$ digit	3.0 digit
TV	Derivative time	—	●	—*	●	$T_v = 1 - 999$ sec	80 sec
TN	Reset time	—	—	●	●	$T_n = 1 - 9999$ sec	350 sec
CY1	Cycle time	—	●	●	●	$C_Y = 0.1 - 99.9$ sec	20.0 sec
Y1	Max. valve stroke	—	●	●	●	$Y_1 = 0 - 100$ %	100 %

Double-setpoint controller with one limit comparator

Symbol	Parameter	Feedback action				Adjustment range	Factory setting
		none	PD	PID	PD/PID		
XP1	Proportional band (heating contact)	—	●	●	●	$X_{p1} = 0 - 9999$ digit	0 digit
XP2	Proportional band (cooling contact)	—	●	●	●	$X_{p2} = 0 - 9999$ digit	0 digit
XSH	Contact spacing	●	●	●	●	$X_{Sh} = 0 - 999.9$ digit	0 digit
XD1	Differential (heating contact)	●	—	—	—	$X_{d1} = 0 - 999.9$ digit	3.0 digit
XD2	Differential (cooling contact)	●	—	—	—	$X_{d2} = 0 - 999.9$ digit	3.0 digit
TV	Derivative time	—	●	—*	●	$T_v = 1 - 999$ sec	80 sec
TN	Reset time	—	—	●	●	$T_n = 1 - 9999$ sec	350 sec
CY1	Cycle time	—	●	●	●	$C_{Y1} = 0.1 - 100.0$ sec	20.0 sec
CY2	Cycle time	—	●	●	●	$C_{Y2} = 0.1 - 100.0$ sec	20.0 sec
Y1	Max. valve stroke	—	●	●	●	$Y_1 = 0 - 100$ %	100 %
Y2	Min. valve stroke	—	●	●	●	$Y_2 = 0 \text{ to } -100$ %	-100 %

Modulating controller with one limit comparator

Symbol	Parameter	Feedback action				Adjustment range	Factory setting
		none	PI	PID	—		
XP1	Proportional band	—	●	●	—	$X_{p1} = 0 - 9999$ digit	0 digit
XSH	Contact spacing	●	●	●	—	$X_{Sh} = 0 - 999.9$ digit	0 digit
XD1	Differential	●	—	—	—	$X_{d1} = 1 - 999.9$ digit	3.0 digit
TN	Reset time	—	●	●	—	$T_n = 1 - 9999$ sec	350 sec

Proportional controller with three limit comparators

Symbol	Parameter	Feedback action				Adjustment range	Factory setting
		P	PI	PD	PID		
XP1	Proportional band	●	—	●	●	$X_{p1} = 0 - 9999$ digit	100 digit
TV	Derivative time	—	●	●	●	$T_v = 1 - 999$ sec	80 sec
TN	Reset time	—	●	—	●	$T_n = 1 - 9999$ sec	350 sec
Y1	Max. valve stroke	●	●	●	●	$Y_1 = 0 - 100$ %	100 %
Y2	Operating point	●	—	●	—	$Y_2 = 0 - 100$ %	50 %

●: adjustable

$X_p = 0$ means feedback switched off

□: factory setting

* $T_v = T_n/4.5$