

**JUMO**

DICON Z

# Microprocessor-Controlled Multi-Channel Controller for Industrial and Process Control Applications

Housing to DIN 43 700

Bezel dimensions 96 x 96 mm

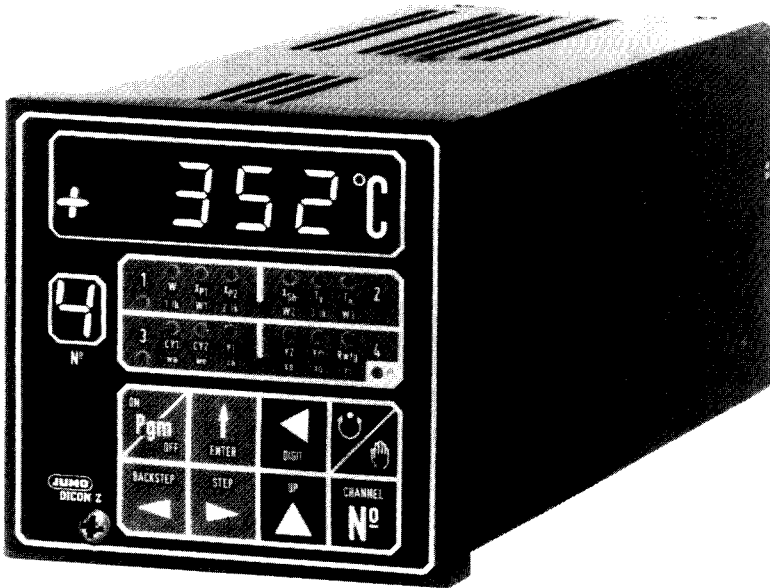

**D 97.500**

5.87/V

## Operating Instructions

|   |           |
|---|-----------|
| <b>1. DESCRIPTION</b> .....   | <b>1</b>  |
| 1.1 Type designation .....  | 1         |
| 1.2 Standard accessories .....                                      | 2         |
| 1.3 Technical data .....  | 3         |
| 1.4 Block diagram .....   | 8         |
| 1.5 Function .....  | 8         |
| 1.6 Standard controller combinations .....                          | 10        |
| <b>2. CONSTRUCTION DETAILS</b> .....                                | <b>11</b> |
| 2.1 Front-panel display and control elements .....                  | 11        |
| 2.2 Rear of controller .....  | 13        |
| 2.3 Internal construction .....                                     | 13        |
| <b>3. INTERNAL SETTINGS</b> .....                                   | <b>14</b> |
| 3.1 Modifying the contact function or output characteristics .....  | 14        |
| 3.2 Selection of linearisation .....                                | 15        |
| 3.3 Keyboard interlock .....  | 16        |
| 3.4 Display resolution .....  | 16        |
| 3.5 Modifying the transmission specification .....                  | 17        |
| 3.6 Interface switching .....                                       | 18        |
| <b>4. INSTALLATION</b> .....  | <b>19</b> |
| 4.1 Mounting .....  | 19        |
| 4.2 Dimensions .....  | 19        |
| 4.3 Electrical connections .....                                    | 20        |
| 4.4 Connection diagram .....  | 21        |
| 4.5 Connection of signal transducers across Zener barriers .....    | 23        |
| 4.6 Line balance .....  | 25        |
| <b>5. COMMISSIONING</b> .....                                       | <b>26</b> |
| 5.1 Self-test and error messages .....                              | 26        |
| 5.2 Data entry .....  | 28        |
| 5.3 Checking input data .....                                       | 44        |
| 5.4 Data correction .....   | 44        |
| <b>6. CONTROL STATION</b> .....                                     | <b>45</b> |
| 6.1 Automatic mode .....  | 45        |
| 6.2 Manual mode .....   | 45        |
| <b>7. INTERFACE</b> .....   | <b>46</b> |
| 7.1 Handshake lines .....   | 46        |
| 7.2 Data lines .....  | 46        |
| 7.3 Transmission specification .....                                | 46        |
| 7.4 Transmission syntax .....                                       | 47        |
| <b>8. DATA BUFFERING IN THE EVENT OF POWER FAILURE</b> .....        | <b>50</b> |
| 8.1 Changing batteries .....  | 50        |
| <b>9. OPTIMISATION</b> .....  | <b>51</b> |
| (Matching controller parameters to the controlled plant)            |           |
| 9.1 Oscillation method according to "Ziegler" and "Nichols" .....   | 52        |
| 9.2 Adjustment according to controlled system characteristics ..... | 52        |
| 9.3 Monitoring optimisation .....                                   | 57        |
| <b>10. MAINTENANCE AND FAULTS</b> .....                             | <b>59</b> |

# 1 DESCRIPTION

Before you work with the DICON Z, please read these operating instructions.

The DICON Z is a microprocessor-controlled multi-channel controller, of modular construction, with a 4½ digit display and a membrane keyboard. Up to 8 relay or binary outputs are possible, with the incorporated limit comparators. It works as a single-point or heat/cool controller or a modulating controller, or as a proportional controller.

A control station is integrated as standard. Very good control accuracy is achieved by self-calibrating input circuits.

Thermocouples, resistance thermometers in a three-wire or four-wire circuit, resistance teletransmitters or signal transducers with a unit signal can be connected directly.

Linearisation for all customary types of resistance thermometers and thermocouple are stored on EPROM. For each channel, a maximum of 24 parameters can be entered, called up and modified as required at any time, via the membrane keyboard. For protection from unauthorised or accidental intervention, selectable keyboard interlocking is incorporated. Interactive operator guidance creates a dialogue between the controller and the user. No programming knowledge is required. Control deviation is indicated for all channels at a glance, by means of light-emitting diodes.

The built-in control station allows smooth transition from automatic to manual operation. The V24 (RS 232 C) interface or TTY interface allows communication with higher-level systems or may be used to drive printers. The housing, with bezel dimensions of 96 x 96 mm, is designed for panel mounting. The controller unit plugs in and is easy to replace. The electronics are modular and therefore particularly easy to service in practical applications.

## 1.1 Type designation

This type designation explains the meaning of the individual fields on the controller rating plate.

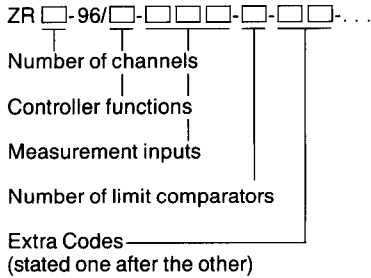

## Selection options

Each selection option is provided with a code number, which is transferred to the corresponding field of the type designation (see rating plate).

| Number of channels       | Code |
|--------------------------|------|
| 1 control channel _____  | 1    |
| 2 control channels _____ | 2    |
| 3 control channels _____ | 3    |
| 4 control channels _____ | 4    |

| Controller functions   | Code |
|--|------|
| Single-point controller<br>with max. contact<br>(relay de-energized when $x > w$ ) _____ | 1    |
| Single-point controller<br>with min. contact<br>(relay de-energized when $x < w$ ) _____ | 2    |
| Heat/cool controller _____   | 3    |
| Modulating controller _____  | 4    |
| Heat/cool humidity controller _____  | 5    |
| Heat/cool climatic controller _____  | 6    |
| Proportional controller _____  | 7    |
| Proportional humidity controller _____   | 8    |
| Proportional climatic controller _____   | 9    |

# 1 DESCRIPTION

| Measurement inputs  | Code  | Number of limit comparators                  | Code        |
|---|-------|--|-------------|
| Resistance thermometer in three-wire circuit                |       | No limit comparator _____                    | 0           |
| Pt 100 _____  | 001   | One limit comparator _____                   | 1           |
| Pt 500 _____  | 002   | Two limit comparators _____                  | 2           |
|   |       | Three limit comparators _____                | 3           |
|   |       | Four limit comparators _____                 | 4           |
| Resistance thermometer in four-wire circuit                 |       | <b>Extra codes</b>                           | <b>Code</b> |
| Pt 100 _____  | 011   | 0/20 mA binary current output _____          | 01*         |
| Pt 500 _____  | 012   | or   |             |
| Resistance transmitter with three-wire connection _____     | 021   | 0/5 V binary current output _____            | 02*         |
| Thermocouples   |       | V.24 (RS 232 C) interface _____              | 11          |
| Cu-CuNi "U" _____   | 041   | or   |             |
| Fe-CuNi "L" _____   | 042   | TTY interface _____                          | 12          |
| NiCr-Ni "K" _____   | 043   | or   |             |
| Pt10Rh-Pt "S" _____   | 044   | V.24gt interface electrically isolated _____ | 13          |
| Pt13Rh-Pt "R" _____   | 045   | or   |             |
| Pt30Rh-Pt "B" _____   | 046   | TTYgt interface electrically isolated _____  | 14          |
| MoRe5-MoRe41 _____  | 047   |  |             |
| Linearised signal transducer with unit signal (current)     |       | Scale marked in °F instead of °C _____       | 21          |
| 0... 1 mA _____   | 051   | or   |             |
| 0...20 mA _____   | 052   | Scale marked in %rh instead of °C _____      | 22          |
| 4...20 mA _____   | 053   | or   |             |
| Linearised signal transducer with unit signal (voltage)     |       | Special marking, e.g. bar _____              | 23          |
| 0...10 mV _____   | 061   |  |             |
| 0... 1 V _____  | 062   |  |             |
| 0...10 V _____  | 063   |  |             |
| Non-linearised signal transducer with unit signal (current) |       |  |             |
| 0... 1 mA (control range _____) *                           | 1..** |  |             |
| 0...20 mA (control range _____) *                           | 2..** |  |             |
| 4...20 mA (control range _____) *                           | 3..** |  |             |
| Non-linearised signal transducer with unit signal (voltage) |       |  |             |
| 0...10 mV (control range _____) *                           | 4..** |  |             |
| 0... 1 V (control range _____) *                            | 5..** |  |             |
| 0...10 V (control range _____) *                            | 6..** |  |             |
| Special range (control range _____) *                       | 900   |  |             |

|  |    |
|--|----|
| V.24 (RS 232 C) interface _____              | 11 |
| or   |    |
| TTY interface _____                          | 12 |
| or   |    |
| V.24gt interface electrically isolated _____ | 13 |
| or   |    |
| TTYgt interface electrically isolated _____  | 14 |
| Scale marked in °F instead of °C _____       | 21 |
| or   |    |
| Scale marked in %rh instead of °C _____      | 22 |
| or   |    |
| Special marking, e.g. bar _____              | 23 |

\* Contacts, e.g. X<sub>k1</sub>, X<sub>k4</sub>, X<sub>k5</sub> specified in clear text (see rating plate)

## 1.2 Standard accessories

- 2 fixing brackets
- 1 set of operating instructions

\* in clear text (see rating plate)  
 \*\* the last two digits of the thermocouple code are inserted instead of the two dots, e. g.:  
 code 241 means a measurement input of 0...20 mA with Cu-CuNi linearisation.

# 1 DESCRIPTION

## 1.3 Technical data

### Controller for connection to resistance thermometer

#### Measurement input

Pt 100, Pt 500  
in three-wire or four-wire circuit

#### Control range

- 200.0... + 850.0°C  
- 328 ... + 1562 °F

#### Line balancing

is not needed for three- and four-wire circuits. When an existing resistance thermometer is connected in a two-wire circuit, line balancing is required. Line balancing may be carried out by means of a line balance resistor or via the keyboard (X0 and X1).

$$R_{\text{balance}} = R_{\text{line}}$$

#### Monitoring the measuring circuit:

In the event of a break or short-circuit in the resistance thermometer all relays are de-energized and the display flashes (-) 19999. In the case of the proportional controller, the output signal goes to minimum.

### Controller for connection to resistance transmitter

50... 30...50 Ohms  
0...200... 0 Ohms  
10...100...10 Ohms

#### Control range

0...100.0% (standard)

#### Humidity controller

According to the psychrometric principle  
(independent of the reference temperature)

#### Measurement input

Two Pt 100 resistance thermometers  
(dry and wet bulb)

#### Control range

0.0...100%rh  
in the range from 0...100°C

#### Monitoring the measurement circuit

Wet and dry probes are monitored for breakage or short-circuits. All relays are de-energized in the event of a fault and the display flashes (-) 19999. In the case of the proportional controller, the output signal goes to minimum.

### Climatic controller

#### Measurement input

Two resistance thermometers  
(dry and wet bulb)

#### Control ranges

0...100%rh  
independent of reference temperature  
in the range from 0...100°C  
and  
-200...+850°C, Pt 100

#### Monitoring the measurement circuit

Wet and dry probes are monitored for breakage or short-circuits. All relays are de-energized in the event of a fault and the display flashes (-) 19999. In the case of the proportional controller, the output signal goes to minimum.

### Controller for connection to thermocouples

#### Measurement input

Cu-CuNi, Fe-CuNi, Ni-CrNi, Pt10Rh-Pt  
Pt13Rh-Pt, Pt30Rh-Pt6h, MoRe5-MoRe41 to  
DIN, IEC or ISA

#### Control ranges

to DIN 43 710

|                  |                   |
|------------------|-------------------|
| Cu-CuNi "U"      | Fe-CuNi "L"       |
| - 200... + 600°C | - 200... + 900°C  |
| - 328... + 932°F | - 328... + 1652°F |

# 1 DESCRIPTION

to DIN IEC 584-1

NiCr-Ni "K"  
- 200... + 1370°C  
- 328... + 2498°F

Pt10Rh-Pt "S"  
- 0... + 1770°C  
- 32... + 3218°F

Pt13Rh-Pt "R"  
- 0... + 1770°C  
- 32... + 3218°F

Pt30Rh-Pt6h "B"  
200... 1800°C  
328... 3272°F

not standardised

MoRe5 - MoRe41  
0... 2000°C  
32... 3632°F

## Electrical isolation

up to max.  $\pm 5$  V

## Monitoring the measurement circuit

In the event of a break or short-circuit in the resistance thermometer, all relays are de-energized and the display flashes (-) 19999. In the case of the proportional controller, the output signal goes to minimum.

## Temperature compensation

standard

## Controller for connection to linearised transducer with unit signal

(current or voltage)

### Measurement input

|           |               |
|-----------|---------------|
| 0... 1 mA | Ri = 50 Ohms  |
| 0...20 mA | Ri = 2.5 Ohms |
| 4...20 mA | Ri = 2.5 Ohms |

|           |              |
|-----------|--------------|
| 0...10 mV | Ri 100 kOhms |
| 0... 1 V  | Ri 50 kOhms  |
| 0...10 V  | Ri 500 kOhms |

### Control range

0.0...100.0% (standard)

## Controller for connection to non-linearised transducers with unit signal

### Measurement input

as for linearised signal transducers with unit signal

## Control ranges

as for resistance thermometers and thermocouples

## Controller for connection to non-linearised resistance transmitter

### Measurement input

specified from keyboard

### Control ranges

as per customer specification (linearisation curves)

## Controller characteristics

### A/D converter

Resolution 15 bit

### Scanning time

max. 500 ms for 4 control loops

### Control accuracy/effect of ambient temperature

Connection of resistance thermometers in three-wire or four-wire circuit and resistance transmitters with three-wire connection  
 $\leq 0.05\% / \leq 0.01\%/20^\circ\text{C}$

Connection of thermocouples

$\leq 0.25\%$  in working range/  
 $\leq 0.05\%/10^\circ\text{C}$

Connection of signal transducers with unit signal (current or voltage)

Current  
 $\leq 0.05\% /$   
 $\leq 0.05\%/10^\circ\text{C}$

Voltage  
 $\leq 0.2\% /$   
 $\leq 0.1\%/10^\circ\text{C}$  for measurement  
input 0...10 mV

$\leq 0.05\% /$   
 $\leq 0.05\%/10^\circ\text{C}$  for measurement  
input 0...1(10) V

These specifications include linearisation tolerances.

### Data entry

Simple input with interactive user guidance

# 1 DESCRIPTION

---

## Function and data keys

8 pushbutton membrane keys for entering a maximum of 24 parameters per control channel.

## Setpoint limitation

Programmable via keyboard (wa/we)

## Keyboard interlock

Internally selectable in 4 stages

## Display

4½ digit, 13 mm high 7-segment display for actual value, all programmable parameters and signalling of input errors

## Channel display

1-digit, 8 mm high 7-segment display for the selected channel

## Information field

15 light-emitting diodes for operator guidance during programming or for display of control deviation

## Controller outputs

Max. 4 relays with potential-free normally-open contact and contact protection switching or 0/20 mA / 0/5 V binary control outputs (plus max. 4 limit comparator relays)

## Breaking capacity

660 W/3 A at 220 V/50 Hz,  
Ohmic load

## Contact service life

Electrical contact life approx. 10<sup>6</sup> switching operations at nominal load

## Outputs with proportional controller

2 outputs with proportional signal (plus max. 4 limit comparator relays)

## Supply voltage

Standard 93...264 V AC, 40...60 Hz;  
20...47 V AC, 40...60 Hz or 20...63 V DC  
(electrically isolated)

## Power consumption

Approx. 20 VA

## Electrical connections

Via panel connectors to DIN 46 244/A,  
4.8 x 0.8 mm

## Permissible ambient temperature range

0...+50°C

## Permissible storage temperature range

-10...+70°C

## Climatic conditions

Class of use KWF to DIN 40 040,  
rel. humidity ≤ 75% rh yearly average,  
without condensation

## Housing

Coated polycarbonate, with plug-in controller unit  
(connected to earth conductor)

## Protection class

to DIN 40 050,  
front IP 54  
rear IP 20

## Installation position

Any position

## Weight

Approx. 1200 g

## Interface (extra code)

V.24 (RS 232 C)  
or TTY (line current)  
(RS 422 to order)

For communication with higher-level systems or switchable via internal bridges to drive printers

## Transmission rate

Set internally from 75...9600 baud

## Electrical isolation

Possible, see available extra codes  
V.24gt or TTYgt

# 1 DESCRIPTION

---

## Control behaviour

### Single-point controller

See feedback structures for heat/cool controller. However, functions  $X_{d2}$ ,  $X_{p2}$ ,  $C_{Y2}$  and  $X_{Sh}$  are not applicable.

### Heat/cool controller without feedback

#### Switching differential $X_d$

The switching differential can be set separately for both contacts.

$X_{d1}$ ,  $X_{d2} = 1...99$  digits.

If  $X_{Sh} = 0$ , the switch-off point corresponds to the setpoint.

#### Example:

99 digits correspond to:

99°C or 9.9°C

depending on the resolution

#### Contact spacing $X_{Sh}$

Contact spacing can be set symmetrically.

$X_{Sh} = 0...9999$  digits.

#### Example:

2000 digits correspond to:

2000°C or 200.0°C

depending on the resolution.

### Heat/cool controller with PD feedback

#### Proportional band $X_p$

The proportional band can be set separately for both contacts.

$X_{p1}$ ,  $X_{p2} = 1...9999$  digits.

The proportional bands are asymmetrical.

#### Contact spacing $X_{Sh}$

Contact spacing can be set symmetrically.

$X_{Sh} = 0...9999$  digits.

#### Derivative action time constant $T_v$

$T_v = 4...999$  s

#### Switching frequency $C_Y$

The maximum switching frequency (operating factor = 50%) can be set separately for both contacts.

$C_{Y1}$ ,  $C_{Y2} = 1...999$  s

### Heat/cool controller with PID feedback

The proportional band can be set separately for both contacts.

$X_{p1}$ ,  $X_{p2} = 1...9999$  digits.

#### Contact spacing $X_{Sh}$

$X_{Sh} = 0...9999$  digits.

#### Reset time $T_n$

$T_n = 16...9999$  s

#### Derivative action time constant $T_v$

$T_v = T_n/4.5$

#### Switching frequency $C_Y$

The maximum switching frequency (operating factor = 50%) can be set separately for both contacts.

$C_{Y1}$ ,  $C_{Y2} = 1...999$  s

### Heat/cool controller with PD/PID feedback

The proportional band can be set separately for both contacts.

$X_{p1} = X_{p2} = 1...9999$  digits.

#### Contact spacing $X_{Sh}$

$X_{Sh} = 0...9999$  digits.

#### Reset time $T_n$

$T_n = 16...9999$  s

#### Derivative action time constant $T_v$

$T_v = 4...999$  s

#### Switching frequency $C_Y$

The maximum switching frequency (operating factor = 50%) can be set separately for both contacts.

$C_{Y1}$ ,  $C_{Y2} = 1...999$  s

# 1 DESCRIPTION

---

## Modulating controller with PI feedback

### Proportional band $X_p$

The proportional band can be set jointly for both contacts.

$X_{p1}, X_{p2} = 1...9999$  digits.

### Contact spacing $X_{Sh}$

Contact spacing can be set symmetrically.

$X_{Sh} = 0...9999$  digits.

### Reset time

$T_n = 16...9999$  s

## Modulating controller with PID feedback

The proportional band can be set jointly for both contacts.

$X_{p1} = 1...9999$  digits.

### Contact spacing $X_{Sh}$

Contact spacing can be set symmetrically.

$X_{Sh} = 0...9999$  digits.

### Reset time

$T_n = 16...9999$  s

### Derivative action time constant $T_v$

$T_v = T_n/4.5$

## Proportional controller with P feedback

### Proportional band $X_p$

$X_p = 1...9999$  digits.

### Reset time $T_n$

$T_n = P$

### Derivative action time constant $T_v$

$T_v = P$

Limitation of output signal Y1

Working point adjustment Y2

Y1, Y2 = 0...100%

## Proportional controller with PD feedback

### Proportional band $X_p$

$X_{p1} = 1...9999$  digits.

### Reset time

$T_n = PD$

### Derivative action time constant $T_v$

$T_v = 4...999$  s

Limitation of output signal Y1

Working point adjustment Y2

Y1, Y2 = 0...100%

## Proportional controller with PI feedback

### Proportional band $X_p$

$X_{p1} = 1...9999$  digits.

### Reset time

$T_n = 16...9999$  s

### Derivative action time constant $T_v$

$T_v = PI$

### Limitation of output signal Y1

Y1 = 0...100%

## Proportional controller with PID feedback

### Proportional band $X_p$

$X_{p1} = 1...9999$  digits.

### Reset time

$T_n = 16...9999$  s

### Derivative action time constant $T_v$

$T_v = 4...999$  s

### Limitation of output signal Y1

Y1 = 0...100%

# 1 DESCRIPTION

## 1.4 Block circuit diagram

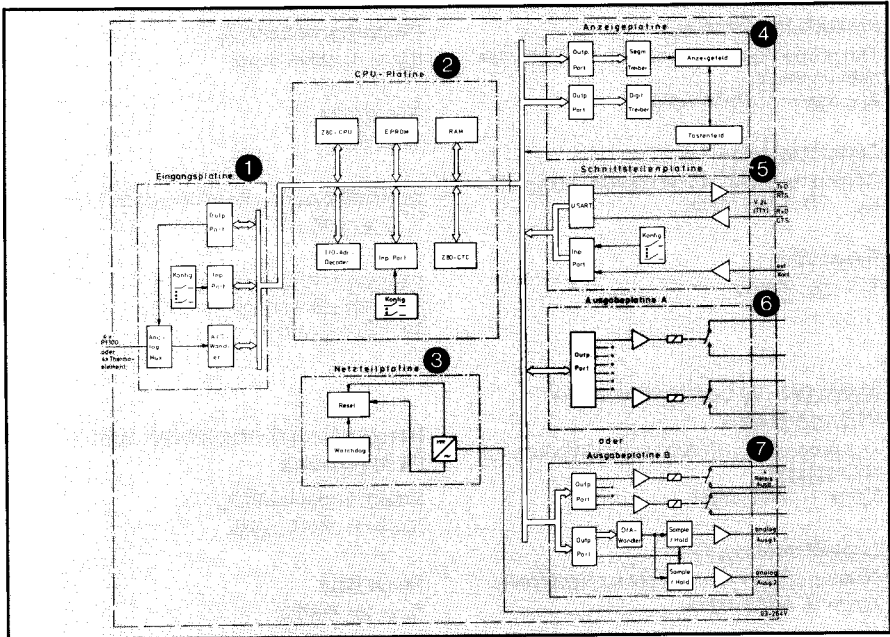

## 1.5 Function

### 1 Input card

The transducer signals are multiplexed, amplified and digitised in the A/D converter, together with the zero potentials and reference signals. Since both the input signals and the reference signals follow the same signal path, measurement errors are compensated immediately (self-calibration).

### 2 CPU card

Located on the signal card are the Z80 microprocessor, 4 timers (Z80CTC), 4 universal slots for memory modules (EPROMs or battery-buffered CMOS RAM chips) and a decoder for input/output port addressing. The Z80 CPU performs all control and regulation functions, multiplexes the display and reads the membrane keyboard.

The CTC timer module controls the clock and the baud rate for the serial interface and serves as a counter for the A/D converter.

### 3 Power supply card

The power supply is a switching PSU. In the case of a DC supply, electrical isolation is ensured between primary and secondary voltages.

The reset circuit monitors the supply voltage to the microprocessor.

The watchdog circuit monitors sequential processing of the program run and trips a specified program start if errors are detected.

### 4 Display card

The 4½ digit actual value display, the channel display and the 15 LEDs are driven in multiplex mode via 2 ports. The same multiplexer is used to interrogate the keyboard sequentially.

# 1 DESCRIPTION

---

## 5 Interface card

The interface card allows a dialogue with other systems (e. g. printer or controller) to take place. The baud rate together with the other interface parameters are set on this card by means of solder straps.

## 6 Output card A

Located on output card A are up to 8 relays which can also be converted to binary outputs. With a relay output, the relay contacts  $X_{k1}$  to  $X_{k4}$  (control contacts) include a spark-suppressor.

## 7 Output card B

In the case of the continuous controller, this card houses 2 analog outputs (0...20 mA, 4...20 mA, etc.) and up to 4 relay outputs. The relay outputs can also be implemented as binary outputs.

# 1 DESCRIPTION

## 1.6 Standard controller combinations\*

(with contact assignment  $X_{k1...8}$ )

### Controller with 1 channel

|             |  |                          |
|-------------|--|--------------------------|
|             | Proportional controller (7)<br>Single-point controller (1/2)<br>Proportional humidity controller (8) | max. 3 limit comparators |
| 1st channel | $X_{k1}$ , 20/21   | $X_{k5}/X_{k6}/X_{k7}$   |

or

|             |  |                          |
|-------------|--|--------------------------|
|             | Heat/cool controller (3)<br>Modulating controller (4)<br>Heat/cool humidity controller (5) | max. 3 limit comparators |
| 1st channel | $X_{k1}/X_{k2}$  | $X_{k5}/X_{k6}/X_{k7}$   |

### Controller with 2 channels

|             |  |                                  |
|-------------|--|----------------------------------|
|             | Proportional controller (7)<br>Single-point controller (1/2)<br>Proportional climatic controller (9) | max. 2 limit comparators/channel |
| 1st channel | $X_{k1}$ , 20/21   | $X_{k5}/X_{k6}$                  |
| 2nd channel | $X_{k2}$ , 30/31   | $X_{k7}/X_{k8}$                  |

or

|             |  |                                  |
|-------------|--|----------------------------------|
|             | Heat/cool controller (3)<br>Modulating controller (4)<br>Heat/cool climatic controller (6)<br>each control channel | max. 2 limit comparators/channel |
| 1st channel | $X_{k1}/X_{k2}$  | $X_{k5}/X_{k6}$                  |
| 2nd channel | $X_{k3}/X_{k4}$  | $X_{k7}/X_{k8}$                  |

### Controller with 3 or 4 channels

|             |   |                                 |
|-------------|---|---------------------------------|
|             | Single-point controller (1/2)<br>each control channel | max. 1 limit comparator/channel |
| 1st channel | $X_{k1}$  | $X_{k5}$                        |
| 2nd channel | $X_{k2}$  | $X_{k6}$                        |
| 3rd channel | $X_{k3}$  | $X_{k7}$                        |
| 4th channel | $X_{k4}$  | $X_{k8}$                        |

\* Other controller combinations to order

The figures in brackets specify the numbers for ordering purposes.

▒ These output terminal designations identify the proportional controller.

## 2 CONSTRUCTION DETAILS

### 2.1 Front-panel display and control elements

- ① 4½ digit display for actual value, setpoint, controller parameters and operator guidance
- ② Display of selected channel
- ③ Fixing screw for controller unit
- ④ Modular plastic housing to DIN 43 700
- ⑤ Information field
- ⑥ Membrane keyboard

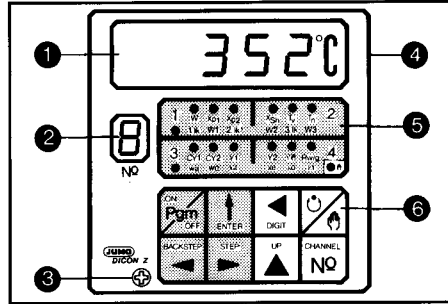

#### Information field

Level 1

W

Setpoints for control contacts °C (°F)

X<sub>p1</sub>

Proportional band for heating contact

X<sub>p2</sub>

Proportional band for cooling contact

X<sub>Sh</sub>

Symmetrical contact spacing

T<sub>v</sub>

Derivative action time constant

T<sub>n</sub>

Reset time

Level 2

1(2,3).lk

Function of limit comparator 1(2,3)

W1(2,3)

Setpoint of limit comparator 1(2,3)

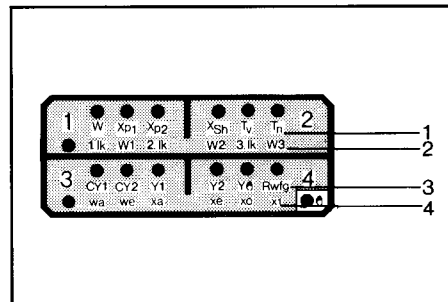

## 2 CONSTRUCTION DETAILS

Level 3

CY1(2)

Maximum switching frequency of heating (cooling) contact (operating factor = 50%)

Y1(2)

Limitation of positive (negative) output signal

Y

Display of Y signal

Rwfg

Setting of resistance transmitter range

Level 4

wa

Setpoint limitation (start of setpoint)

we

Setpoint limitation (end of setpoint)

Xa

Start of measurement range

Xe

End of measurement range

X0 (X1)

Correction of actual value display

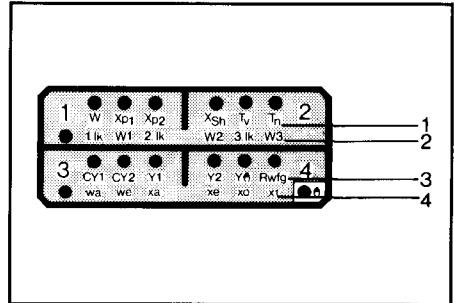

### Membrane keyboard

- 1 **Programming**  
Key for entry, recall or correction of controller parameters
- 2 **Data entry**  
All entered data is transferred to storage when this key is pressed
- 3 **STEP**  
Key to cycle forwards through parameters
- 4 **BACKSTEP**  
Key to cycle backwards through parameters

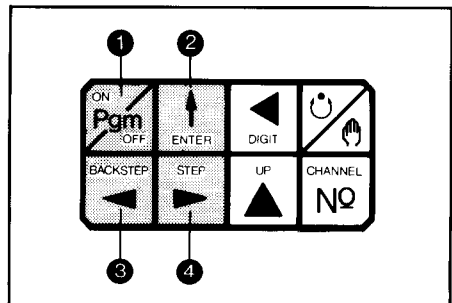

## 2 CONSTRUCTION DETAILS

- ⑤ **Digit**  
This key selects the digit to be changed in the display
- ⑥ **Automatic/manual**  
To switch from automatic control to manual operation
- ⑦ **Channel**  
This key selects and displays the desired channel
- ⑧ **UP**  
Key to increment the selected digit

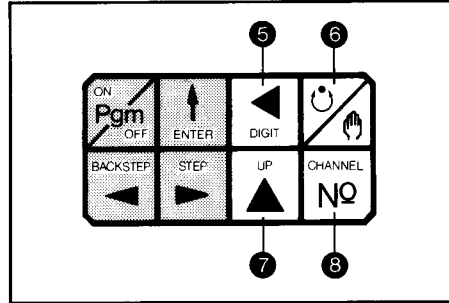

### 2.2 Rear of controller

- ① Polycarbonate housing
- ② Panel connector to DIN 46 244/A  
4.8 x 0.8 mm

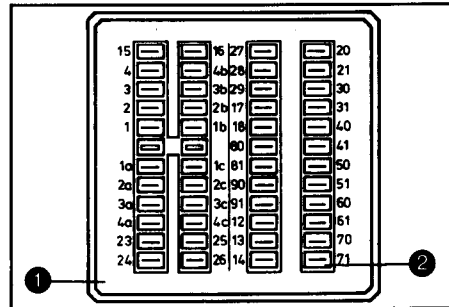

### 2.3 Internal construction

- ① Output card
- ② Power supply card
- ③ Serial interface
- ④ Input card
- ⑤ CPU card

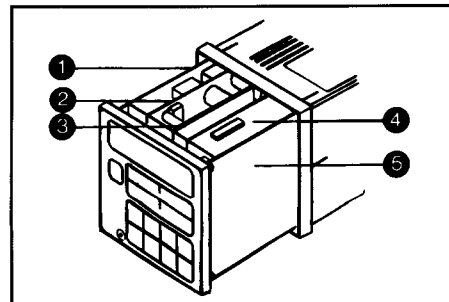

### 3 INTERNAL SETTINGS

The controller unit can be pulled out from the housing after loosening the cross-head screw.

Note:  
The internal settings apply for all channels.

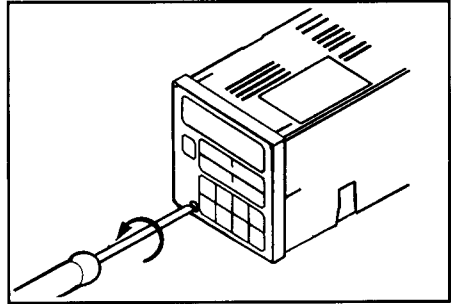

#### 3.1 Changing the contact function or output characteristic

If the DICON Z is programmed as a single-point controller, the standard maximum contact function (relay de-energizes when  $x > w$ ) can be changed to a minimum contact (relay de-energizes when  $x < w$ ) by means of solder strap 5.

Strap closed = minimum contact  
Strap open = maximum contact

Depending on the version of the controller, the modification acts:

on contact  $X_{k1}$  for one channel,  
on contacts  $X_{k1}$  and  $X_{k2}$  for 2 channels  
and  
on contacts  $X_{k1}$ ,  $X_{k2}$ ,  $X_{k3}$  and  $X_{k4}$  for 4 channels.

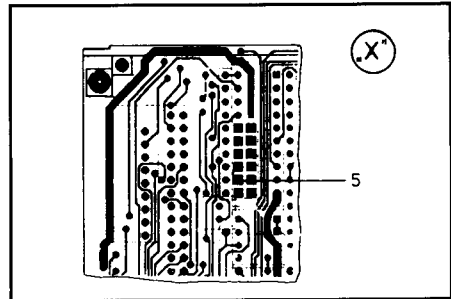
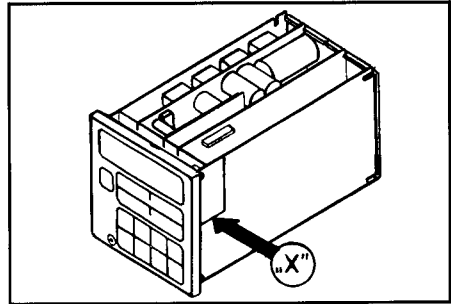

If the DICON Z is programmed as a proportional controller, the standard "falling" characteristic function can be changed to a "rising" function by means of solder strap 5.

Solder strap closed = falling  
Solder strap open = rising

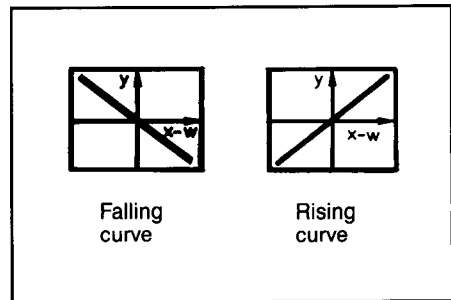

### 3 INTERNAL SETTINGS

#### 3.2 Selection of linearisation

The DICON Z incorporates linearisation for all customary types of signal transducer. The type of sensor can be changed simultaneously for channels 1...4, by means of bridges 29, 28, 27, 26 and 17 (shown magnified in the illustration below) as follows:

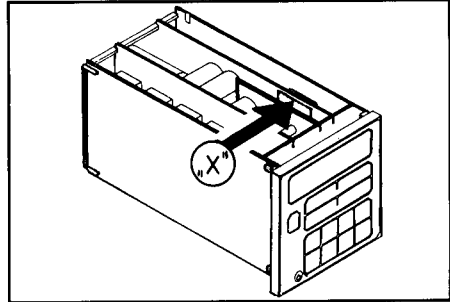

#### Resistance thermometer and resistance teletransmitter input (card 75.045.15.03)

| Br 17 | Br 26 | Br 27 | Br 28 | Br 29 | Linearisation                  |
|-------|-------|-------|-------|-------|--------------------------------|
| x     | x     | x     | ○     | x     | Pt 100                         |
| ○     | x     | x     | x     | x     | Resistance transmitter, linear |
| -     | -     | -     | -     | -     | -                              |

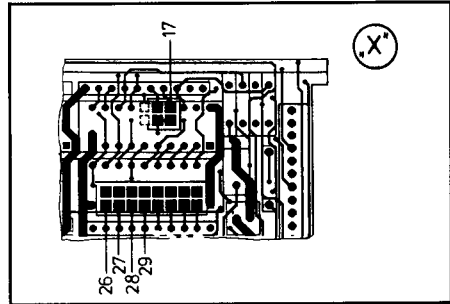

#### Thermocouple input (card 75.045.15.04)

| Br 26 | Br 27 | Br 28 | Br 29 | Linearisation   |
|-------|-------|-------|-------|-----------------|
| ○     | x     | x     | ○     | Cu-CuNi "U"     |
| x     | ○     | x     | x     | Fe-CuNi "L"     |
| x     | ○     | x     | ○     | NiCr-Ni "K"     |
| x     | ○     | ○     | x     | Pt10Rh-Pt "S"   |
| x     | ○     | ○     | ○     | Pt13Rh-Pt "R"   |
| ○     | x     | x     | x     | Pt30Rh-Pt6h "B" |
| ○     | x     | ○     | ○     | MoRe5-MoRe41    |

#### Unit signal input Current or voltage (card 75.045.15.04)

| Br 26  | Br 27 | Br 28 | Br 29 | Linearisation |
|--|-------|-------|-------|---------------|
| x  | x     | x     | ○     | without       |
| In the case of a unit signal with linearisation, bridges 26...29 must be chosen according to the type of element |       |       |       | with          |

x = closed    ○ = open

## 3 INTERNAL SETTINGS

### 3.3 Keyboard interlock

The controller keyboard has a 4-way interlock for protection from unintentional or unauthorised use, by means of switches S39 and S40:

| S39                                 | S40                                 | Adjustable parameters  |
|-------------------------------------|-------------------------------------|--|
| <input type="radio"/>               | <input type="radio"/>               | None   |
| <input type="radio"/>               | <input checked="" type="checkbox"/> | W, W1, W2, W3  |
| <input checked="" type="checkbox"/> | <input type="radio"/>               | W, W1, W2, W3,<br>X <sub>p1</sub> , X <sub>p2</sub> , X <sub>Sh</sub> ,<br>T <sub>v</sub> , T <sub>n</sub> , C <sub>Y1</sub> , C <sub>Y2</sub> |
| <input checked="" type="checkbox"/> | <input checked="" type="checkbox"/> | All  |

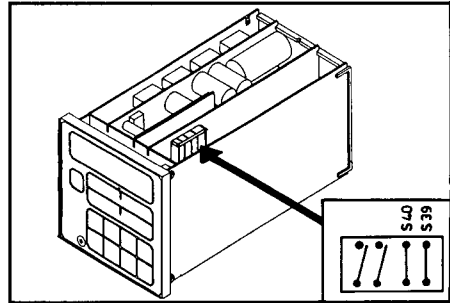

### 3.4 Display resolution

| S41                                 | S42                                 | Display |
|-------------------------------------|-------------------------------------|---------|
| <input type="radio"/>               | <input type="radio"/>               | 1234*   |
| <input checked="" type="checkbox"/> | <input type="radio"/>               | 123.4** |
| <input type="radio"/>               | <input checked="" type="checkbox"/> | 12.34   |
| <input checked="" type="checkbox"/> | <input checked="" type="checkbox"/> | 1.234   |

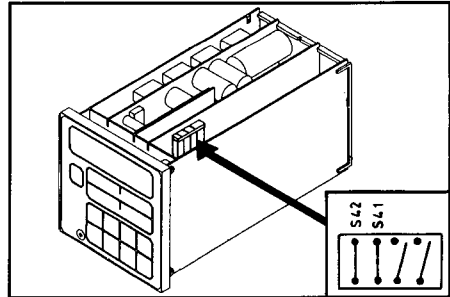

\* standard for thermocouple and humidity input

\*\* standard for resistance thermometer and resistance transmitter input and for transducers with unit signal (current or voltage)

x = closed

○ = open

■ = standard setting

# 3 INTERNAL SETTINGS

## 3.5 Modifying the transmission specification

### Baud rate

The baud rate is set internally by means of bridges 50, 51 and 52, in eight steps from 75...9600 baud.

| Br 52 | Br51 | Br50 | Baud rate |
|-------|------|------|-----------|
| x     | x    | x    | 75        |
| x     | x    | ○    | 150       |
| x     | ○    | x    | 300       |
| x     | ○    | ○    | 600       |
| ○     | x    | x    | 1200      |
| ○     | x    | ○    | 2400      |
| ○     | ○    | x    | 4800      |
| ○     | ○    | ○    | 9600      |

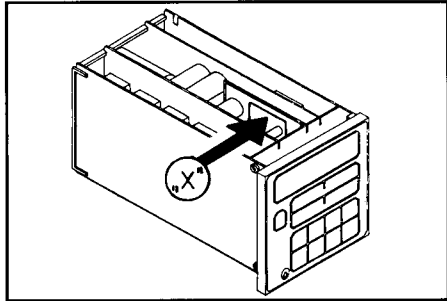

### Data format

|      | ○             | x           |
|------|---------------|-------------|
| Br53 | Parity-odd    | Parity-even |
| Br54 | No parity bit | Parity bit  |
| Br55 | 1 stop bit    | 2 stop bit  |
| Br56 | 8 data bits   | 7 data bits |
| Br57 | Terminal off  | Terminal on |

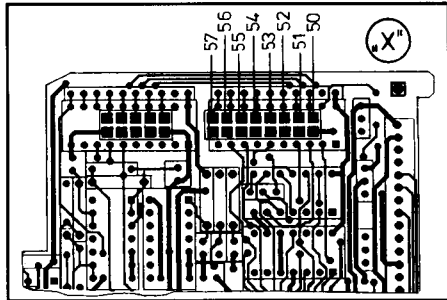

- x = closed
- = open
- = standard setting

### 3 INTERNAL SETTINGS

#### 3.6 Interface switching

The standard interface setting is "communication". Solder bridges 58, 59 and 60 allow the controller to be switched to "send" (see description of "Interface", section 7).

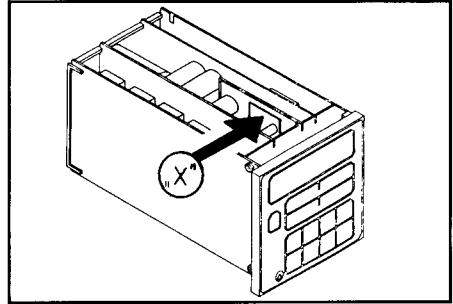

| Br60                             | Br59                             | Br58                             | Output times         |      |
|----------------------------------|----------------------------------|----------------------------------|----------------------|------|
| <input type="radio"/>            | <input type="radio"/>            | <input type="radio"/>            | <b>Communication</b> | send |
| <input type="radio"/>            | <input type="radio"/>            | <input checked="" type="radio"/> | 15 min.              |      |
| <input type="radio"/>            | <input checked="" type="radio"/> | <input type="radio"/>            | 30 min.              |      |
| <input type="radio"/>            | <input checked="" type="radio"/> | <input checked="" type="radio"/> | 1 hr.                |      |
| <input checked="" type="radio"/> | <input type="radio"/>            | <input type="radio"/>            | 2 hrs.               |      |
| <input checked="" type="radio"/> | <input type="radio"/>            | <input checked="" type="radio"/> | 4 hrs.               |      |
| <input checked="" type="radio"/> | <input checked="" type="radio"/> | <input type="radio"/>            | 8 hrs.               |      |
| <input checked="" type="radio"/> | <input checked="" type="radio"/> | <input checked="" type="radio"/> | Customer spec.       |      |

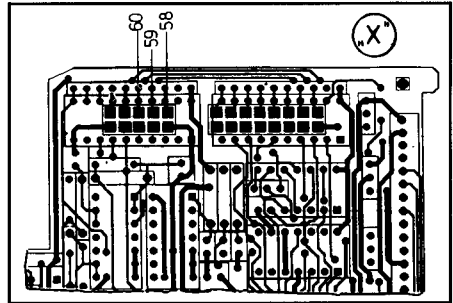

- x = closed
- o = open
- = standard setting

#### "Send"

The controller transmits the setpoints and actual values of the individual channels at regular intervals (e.g. to a printer).

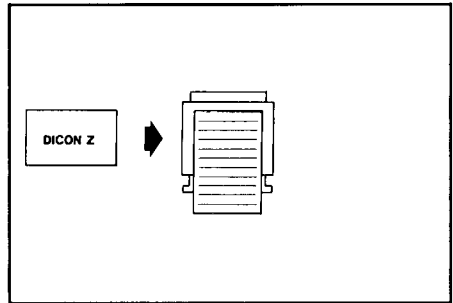

#### "Communication"

The controller operates as a receiver but acknowledges any data and replies to parameter queries. Please note the contents of Section 7 in this context!

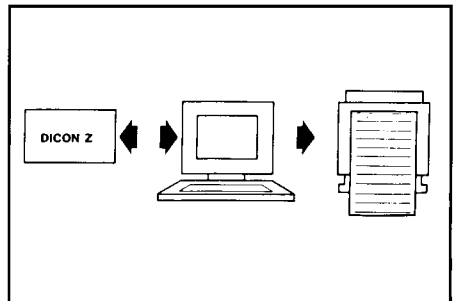

## 4 INSTALLATION

### 4.1 Mounting

Insert the controller into the panel cutout from the front. The dimensions for the panel cutout are given in the drawing opposite.

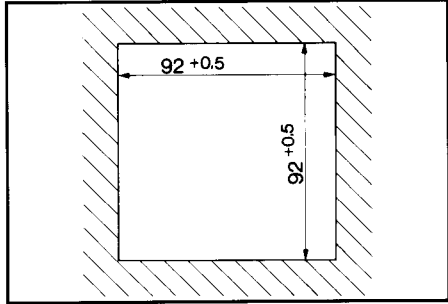

Insert the two brackets into the dovetail guides and tighten uniformly with a screwdriver.

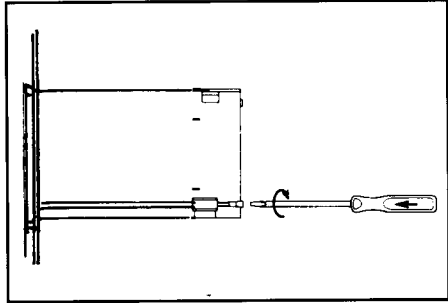

### 4.2 Dimensions

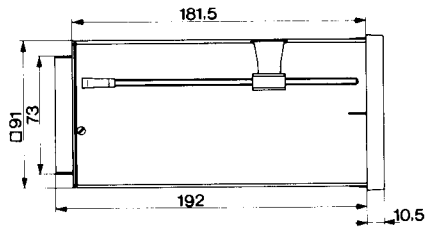
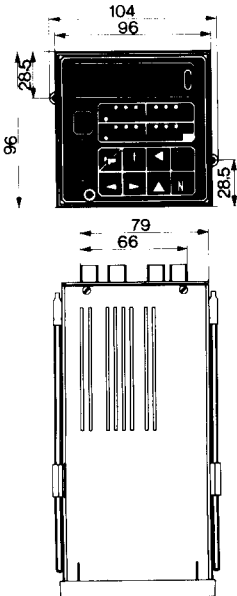

## 4 INSTALLATION

---

### 4.3 Electrical connections

The controller operates at an ambient temperature of 0...50°C, relative humidity  $\leq$  75% rh yearly average, without condensation. Make the electrical connections to the controller using panel connectors to DIN 46 244/A, 4,8 x 0,8 mm, according to the connection diagram in Section 4.4. The respective VDE or national regulations must be complied with.

#### Important notes on installation

- All probe and signal lines must be laid as far as possible from control and mains voltage lines.
- If several electronic devices are installed, a separate mains supply line including earth conductor connection is advisable.
- Earth screened measurement lines only at the controller.
- Maximise the distance between electronic devices and contactor circuits.
- If inductive loads such as relays, solenoid valves, etc. are installed in the vicinity of the unit, it is advisable to suppress the contactor coil by means of an RC combination.
- Do not connect any control current line (relays, contactors) to the mains power terminals of the unit.
- Please comply with the relevant safety regulations for overtemperature monitoring.
- The voltage difference in the case of thermocouple inputs is  $\pm 5$  V.

## 4 INSTALLATION

### 4.4 Connection diagram

Rear view with panel connectors

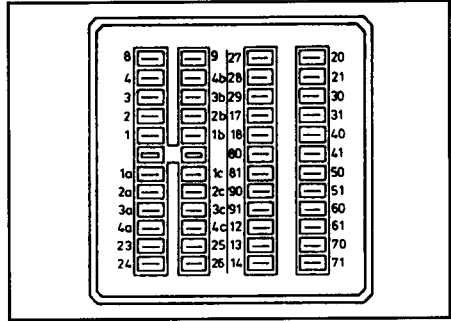

| Connection for                         | Abbreviation | Contact assignment   |  | Connection |
|--|--------------|--|--|------------|
| Relay output<br>1st control contact    | $X_{k1}$     | 20 (P) Pole<br>21 (S) NOC  |  |            |
| Relay output<br>2nd control contact    | $X_{k2}$     | 30 (P) Pole<br>31 (S) NOC  |  |            |
| Relay output<br>3rd control contact    | $X_{k3}$     | 40 (P) Pole<br>41 (S) NOC  |  |            |
| Relay output<br>4th control contact    | $X_{k4}$     | 50 (P) Pole<br>51 (S) NOC  |  |            |
| Relay output<br>1st limit comparator   | $X_{k5}$     | 60 (P) Pole<br>61 (S) NOC  |  |            |
| Relay output<br>2nd limit comparator   | $X_{k6}$     | 70 (P) Pole<br>71 (S) NOC  |  |            |
| Relay output<br>3rd limit comparator   | $X_{k7}$     | 80 (P) Pole<br>81 (S) NOC  |  |            |
| Relay output<br>4th limit comparator   | $X_{k8}$     | 90 (P) Pole<br>91 (S) NOC  |  |            |
| supply voltage<br>acc. to rating plate |              | 12 L1 Live conductor<br>13 N Neutral conduct.<br>Earth conductor |  |            |
| Setpoint defined<br>by current         | Wi020        | 8 -<br>9 +   |  |            |

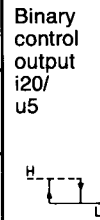

## 4 INSTALLATION

| Input circuit                               | Abbrev.                 | Channel          | Channel              | Channel              | Channel              |                                    | Connection      |  |
|---|-------------------------|------------------|----------------------|----------------------|----------------------|------------------------------------|-----------------|--|
| Thermocouple                                | t                       | 1<br>2           | 1a<br>2a             | 1b<br>2b             | 1c -<br>2c +         |                                    |                 |  |
| Input signal<br>Current or voltage          | e                       | 1<br>2           | 1a<br>2a             | 1b<br>2b             | 1c -<br>2c +         |                                    |                 |  |
| Resistance thermometer<br>in 2 wire circuit | w                       | 1<br>2           | 1a<br>2a             | 1b<br>2b             | 1c<br>2c             |                                    |                 |  |
| Resistance thermometer<br>in 3 wire circuit | w                       | 1<br>2<br>3      | 1a<br>2a<br>3a       | 1b<br>2b<br>3b       | 1c<br>2c<br>3c       |                                    |                 |  |
| Resistance thermometer<br>in 4 wire circuit | w                       | 1<br>2<br>3<br>4 | 1a<br>2a<br>3a<br>4a | 1b<br>2b<br>3b<br>4b | 1c<br>2c<br>3c<br>4c |                                    |                 |  |
| Resistance transmitter                      | w.../wfg                | 1<br>2<br>3      | 1a<br>2a<br>3a       | 1b<br>2b<br>3b       | 1c<br>2c<br>3c       | S = slider<br>A = start<br>E = end |                 |  |
| Serial interface V.24                       | $\overline{\text{RxD}}$ | 23<br>29 GND     |                      |                      |                      | IN                                 | Receive data    |  |
| Serial interface V.24                       | $\overline{\text{TxD}}$ | 25<br>29 GND     |                      |                      |                      | OUT                                | Transmit data   |  |
| Serial interface V.24                       | CTS                     | 24<br>29 GND     |                      |                      |                      | IN                                 | Clear to send   |  |
| Serial interface V.24                       | RTS                     | 26<br>29 GND     |                      |                      |                      | OUT                                | Request to send |  |
| Serial interface TTY                        |                         | 23<br>24<br>29   |                      |                      |                      | IN                                 |                 |  |
| Serial interface TTY                        |                         | 25<br>26<br>29   |                      |                      |                      | OUT                                |                 |  |

# 4 INSTALLATION

## 4.5 Connection of measurement sensors across Zener barriers

Connection of a resistance thermometer in a two-wire circuit across one Zener barrier (for single channel version only)

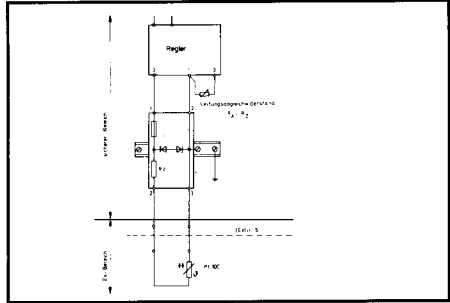

Connection of a resistance thermometer in a two-wire circuit across two Zener barriers

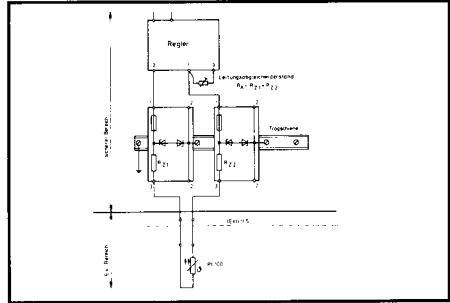

Connection of a resistance thermometer in a three-wire circuit across two Zener barriers (for single channel version only)  
R = tolerance of barriers

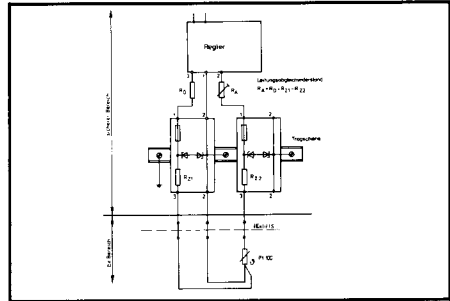

Connection of a resistance thermometer in a three-wire circuit across three Zener barriers

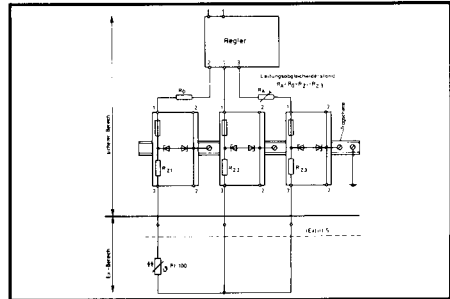

## 4 INSTALLATION

Connection of a resistance thermometer in a three-wire circuit across three Zener barriers

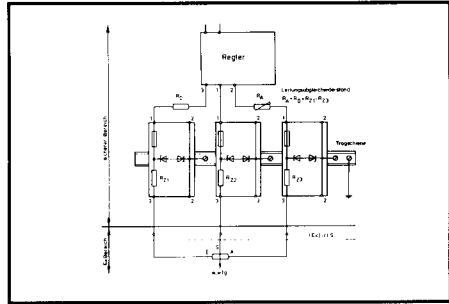

Connection of a thermocouple across two Zener barriers

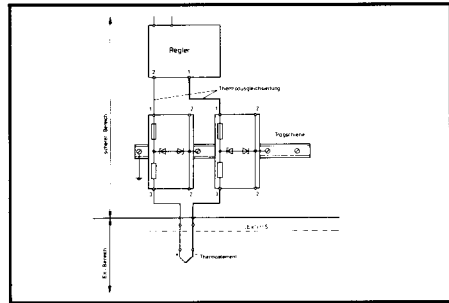

## 4 INSTALLATION

### 4.6 Line balance

#### For thermocouples:

Line balancing is not necessary in the case of connection to thermocouples. The deviation is  $1 \mu\text{V}/10 \text{ Ohms}$ . Comparison point temperature compensation is incorporated in the DICON Z. The equalisation line must be taken up to the panel connectors on the controller.

The measurement circuit is monitored by a thermocouple fuse. If the measurement circuit is interrupted, all relays are switched off.

#### For resistance thermometers in a (standard) three-wire circuit or a four-wire circuit:

In the case of connection to resistance thermometers in a three-wire or four-wire circuit, line balancing is not required.

#### For resistance thermometers in a two-wire circuit:

1st option: Faults occurring because of the electrical resistor  $R_{L1}$  and  $R_{L2}$  on the sensor line can be compensated by a balancing resistor  $R_{LAW}$ . ( $R_{LAW} = R_{L1} + R_{L2}$ ).

Line balancing is carried out using an external line balance resistor at the measurement input.

2nd option: Balancing using parameters  $X_p/X_1$ . In this case terminals 1 and 3 must be bridged. This programming operation is described in section 5.2!

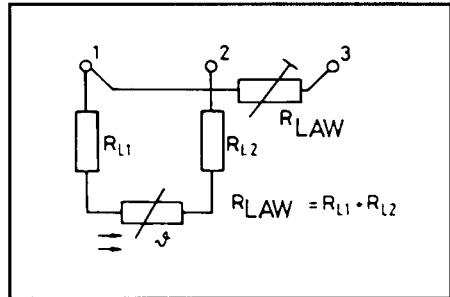

## 5 COMMISSIONING

### 5.1 Self-test and error messages

After the supply voltage is applied, the controller carries out a self-test routine. This is indicated visually: the 5 horizontal segments in the top, centre and bottom levels of the display light up several times one after the other.

If the controller has detected a fault during the self-test, it indicates this by means of the following error message:

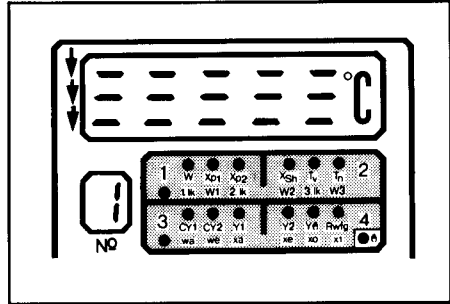

#### Setting in unit is incorrect!

To rectify: check bridge positions and change if necessary (refer to section 3)!

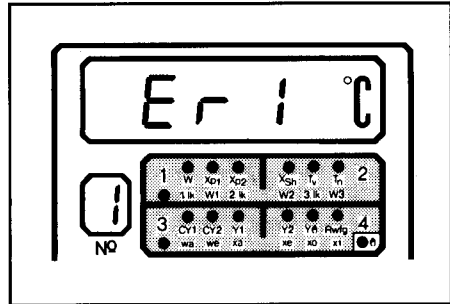

#### Illegal programming constants for X0 and X1!

Applies when  $X0 = X1$  or  $X1 = 0$ .

To rectify: press any key and the error message will disappear. The controller reverts to the factory calibration settings.

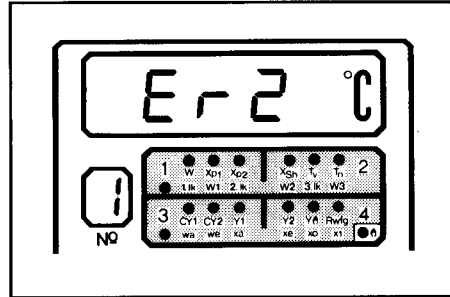

#### Calibration error!

To rectify: not possible.  
Return controller for checking.

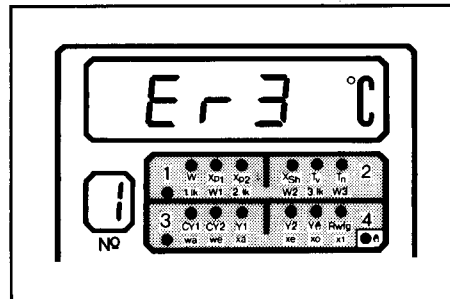

## 5 COMMISSIONING

### Data buffer at risk!

To rectify: press any key and the error message will disappear. Change batteries within the next 4 weeks (refer to section 8.1).

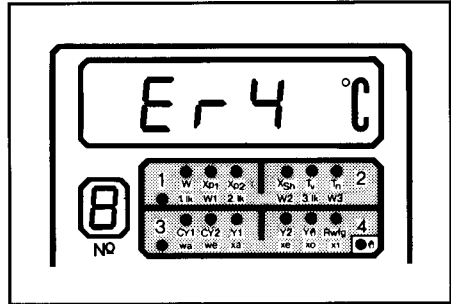

### Resistance thermometer and thermocouple open circuit

To rectify: check probes, connection line and balance line!

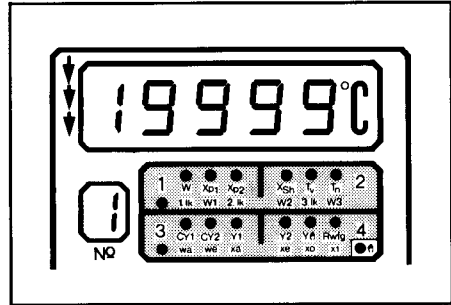

### Resistance thermometer short-circuit or pole inversion of thermocouples

To rectify: check probes, connection line and balance line!

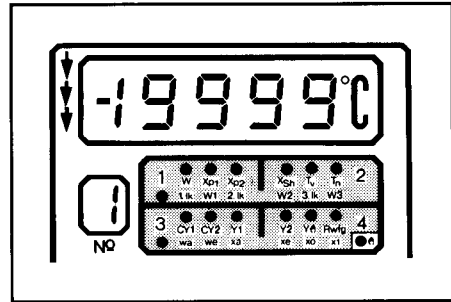

If the actual value display flashes, this indicates a faulty channel! The faulty channel(s) can be selected by pressing the "CHANNEL" key. You will recognise this from the error messages described above.

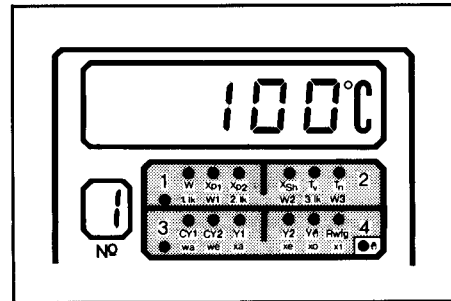

# 5 COMMISSIONING

## 5.2 Data entry

After the self-test routine, the display shows the actual value of the 1st channel (in the illustration on the right: assumed probe temperature 20°C). There is a figure 1 (for channel 1) in the No. display field. The 12 LEDs, divided into four groups, indicate the control deviation of channels 1...4.

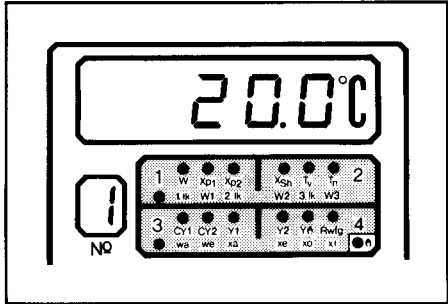

The left-hand LED signals:  
actual value smaller than setpoint ( $x < w$ )

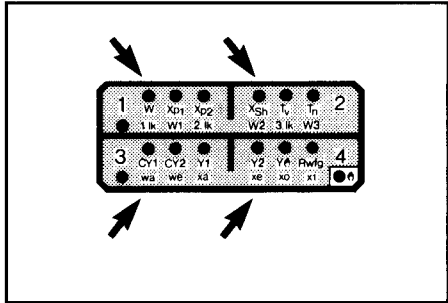

The central LED signals:  
actual value equal to setpoint ( $x = w$ )  
 $\pm 50$  digits, corresponding to resolution

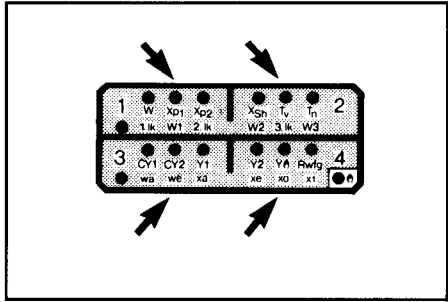

The right-hand LED signals:  
actual value greater than setpoint ( $x > w$ )

The actual values for the other channels can be displayed by pressing the "CHANNEL" key.

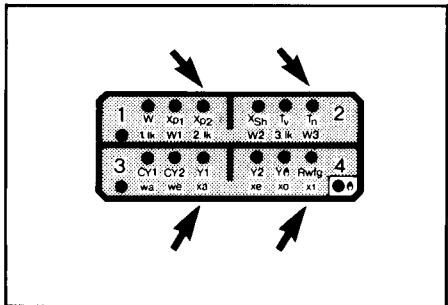

## 5 COMMISSIONING

### Switching to programming mode

Data entry is initiated by pressing the "Pgm" key.

The LED for setpoint w flashes. The display shows the setpoint for the driven channel. The low-value position flashes.

The setpoints for the other channels can be displayed by pressing the "CHANNEL" key.

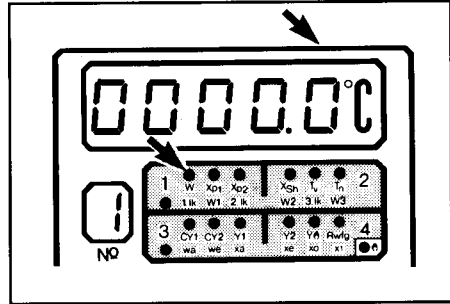

All the other parameters are selected by the "STEP" and "BACKSTEP" keys. The four levels are cycled through in the sequence 1, 3, 2, 4; from left to right by pressing the "STEP" key and from right to left by pressing the "BACKSTEP" key. Parameters not included in the controller version are skipped automatically.

The parameters for the other channels can be displayed by pressing the "CHANNEL" key.

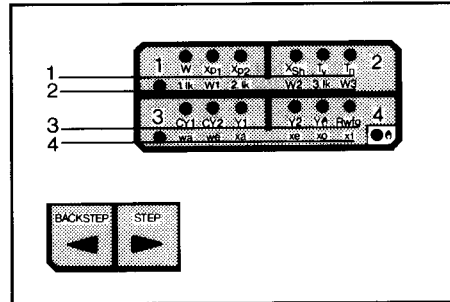

The flashing position is incremented, i.e. increased by one digit, by pressing the "UP" key. After the first change, the digit stops flashing. Pressing this key continuously will increment the digit automatically every 0.5 seconds.

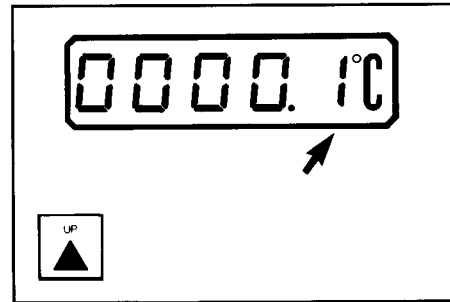

When the "DIGIT" key is pressed, the next higher position flashes and can be changed by pressing the "UP" key.

Once all digits have been set, the controller accepts the value into the program memory after the "ENTER" key is pressed.

The LED for next parameter flashes and the works setting is displayed.

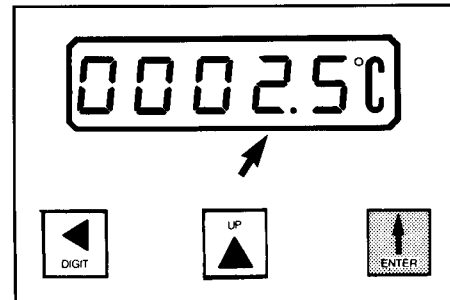

## 5 COMMISSIONING

Illegal entries, e.g. values above or below the setting range, are not accepted by the controller. After the "ENTER" key is pressed, the display will indicate the permissible maximum or minimum values. Data entry can be repeated.

### Setpoint w

Within the range of measurement, i.e.  $w_a$  = start of setpoint and  $w_e$  = end of setpoint, it is possible to specify the setpoint and have the value accepted into programm memory by pressing "ENTER". The LED for the next parameter will flash and the works setting will be displayed.

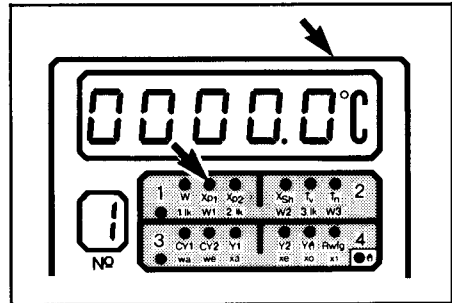

### Proportional band $X_{p1}$ (Heating)

This parameter is shown in clear text. The display indicates "OFF", i.e. feedback is switched off. After pressing the "Digit" key, the next lower position will flash. The range of adjustment for  $X_{p1}$  is 1...9999 digits. After pressing the "Enter" key, the set proportional band is accepted into the program memory.

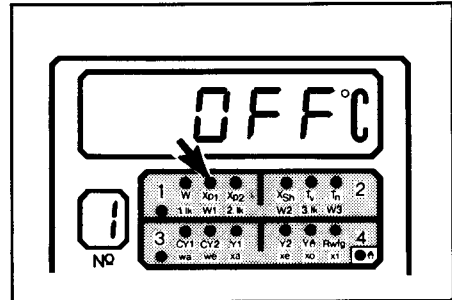

If no proportional band is to be entered, the clear text "OFF" will reappear after cycling through the 5 positions by means of the "Digit" key (feedback switched off).

### Proportional band $X_{p2}$ (cooling)

This parameter will flash only if the DICON Z is programmed as a heat/cool controller. The same procedure for setting and range of adjustment applies as for  $X_{p1}$  (heating).

## 5 COMMISSIONING

### Contact spacing $X_{Sh}$

(only for heat/cool controller and modulating controller)

If feedback is switched off, or in the case of a PD structure, or for a modulating controller, the contact spacing defines a dead band in which the controlled variable is not controlled. In the case of a heat/cool controller with a PID or PD/PID structure, contact spacing is overcome by the integral element.

However, it is possible, by increasing the contact spacing, to reduce the sensitivity of the controller in the regulation ratio zone to 0%, thereby avoiding alternate heating and cooling action.

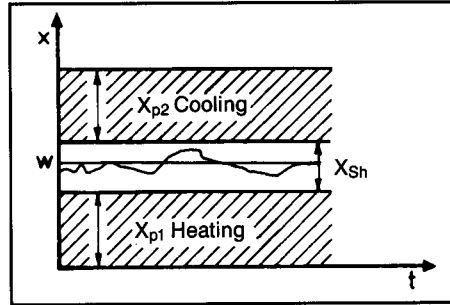

## 5 COMMISSIONING

### Derivative action time constant $T_v$ and reset time $T_n$

The setting for these parameters is effective only when feedback is switched in, i.e. when a proportional band has already been entered (see description of  $X_p$ ).

#### Example

Desired feedback PD in the case of a single-point control function:

Parameter  $T_v$  can be changed in the range from 4...999 s by means of the "UP", "DIGIT" and "ENTER" keys (standard setting is 80 s).

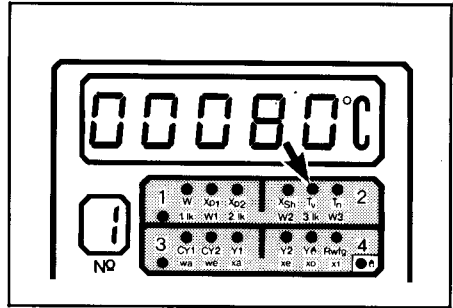

Parameter  $T_n$  is set in clear text "Pd" using the "UP", "DIGIT" and "ENTER" keys (standard setting 350 s).

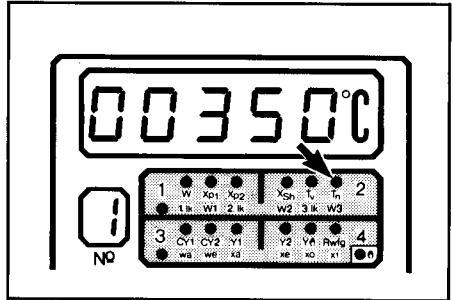

The following tables show the possible settings for  $T_v$  and  $T_n$  for the various versions of the controller and the corresponding feedback structures.

## 5 COMMISSIONING

---

### Single-point and heat/cool controller

| Controller structure | Ranges of adjustment |             |
|----------------------|----------------------|-------------|
|                      | $T_v$                | $T_n$       |
| PD                   | 4...999 s            | Pd          |
| PID*                 | PId                  | 16...9999 s |
| PD/PID               | 4...999 s            | 16...9999 s |

\* With a PID structure  $T_v = \frac{T_n}{4.5}$

### Modulating controller

| Controller structure | Ranges of adjustment |             |
|----------------------|----------------------|-------------|
|                      | $T_v$                | $T_n$       |
| PI                   | PI                   | 16...9999 s |
| PID*                 | PId                  | 16...9999 s |

\* With a PID structure  $T_v = \frac{T_n}{4.5}$

### Proportional controller

| Controller structure | Ranges of adjustment |             |
|----------------------|----------------------|-------------|
|                      | $T_v$                | $T_n$       |
| P                    | P                    | P           |
| PD                   | 4...999 s            | Pd          |
| PI                   | PI                   | 16...9999 s |
| PID                  | 4...999 s            | 16...9999 s |

## 5 COMMISSIONING

### Switching frequency (switching differential) of heating contact $C_{Y1}$

The switching ratio, and therefore the mean correcting variable

$$Y = \frac{t_{on}}{t_{on} + t_{off}}$$

are determined by the feedback.

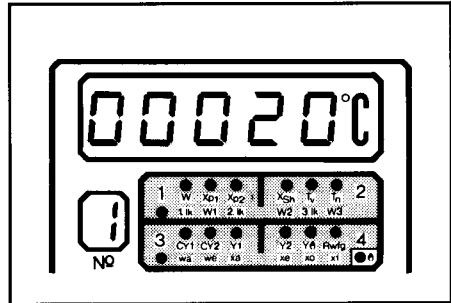

If feedback is switched on,  $C_Y$  determines the maximum switching frequency.

It is set by means of the period duration from 1...99 s. The switching ratio remains unchanged.

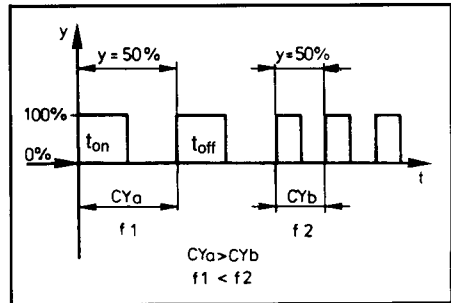

With the feedback switched off, the switching differential here is programmable  $X_d = 0...999$  digits programmable (also valid for modulating controller)

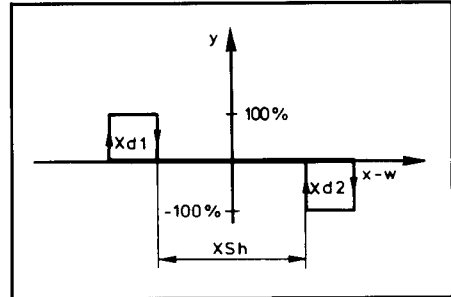

### Switching frequency (switching differential) of cooling contact $C_{Y2}$

This parameter will flash only if the DICON Z is programmed as a heat/cool controller. The same procedure for setting and the same range of adjustment apply as for  $C_{Y1}$  (heating).

#### Note:

With a modulating controller (for exception see 2nd paragraph) and with a proportional controller, parameters  $C_{Y1}$  and  $C_{Y2}$  are not used.

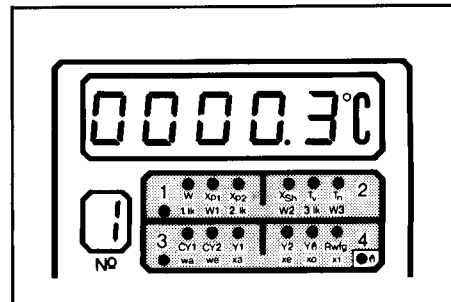

## 5 COMMISSIONING

### Limitation of the output signal (1, 2)

Outside the proportional band, the output signal of the controller is 100% or 0% (-100%) respectively.

In the case of the proportional controller, the output signal changes continuously within the proportional band between 0 and 100%. In the case of the single-point or heat/cool controller, the output signal in the  $X_p$  band is determined by a control contact switching ratio.

$$Y = \frac{t_{on}}{t_{on} + t_{off}}$$

By limiting the output signal, e.g. to 70%, an output of only 70% maximum can be achieved even outside the  $X_p$  band. This is also implemented by means of the clock ratio, or continuously in the case of the proportional controller. In specific cases, setting this parameter permits more favourable start-up behaviour (the start-up curve becomes flatter).

This parameter is useful, e.g. in the case of overrated power requirements etc. Correct regulation, however, is possible only if the controlled plant is designed so that the specified setpoint can still be achieved even at 70% of output. Control behaviour in normal operating conditions depends on the limitation of the regulation ratio.

### Parameter $Y_1$

The output signal of the heating contact can be limited between 0...+100%.  $Y_1$  is effective only if feedback is switched on.

Modulating controller with control station:  
Limitation of the maximum regulation ratio

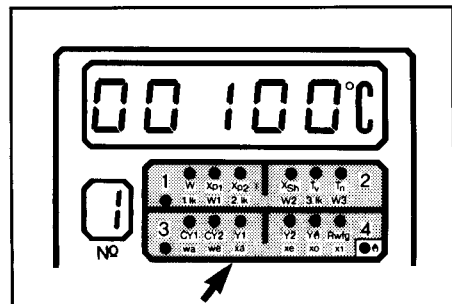

## 5 COMMISSIONING

### Parameter Y<sub>2</sub>

Heat/cool controller:

Limitation of the output signal for the cooling contact between 0...-100%, with feedback switched on.

Heat/cool controller with control station:

Limitation of the minimum regulation ratio (0...100%)

Proportional controller:

Moving the working point (0...100%)

Working point displacement (abbrev. AP) is effective only with a P or PD structure.

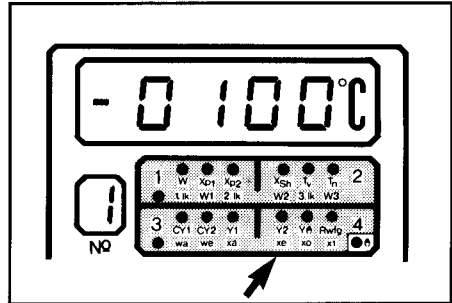

### Example:

In built-up condition, and with a P or PD structure, the following points apply:

1. From setpoint = actual value, it follows:

$$\text{Correcting variable } Y = Y_2$$

$$\text{Also true, however: } Y \leq Y_1$$

2. From setpoint  $\neq$  actual value, it follows:

$$Y = \frac{w-x}{X_p} + Y_2$$

$$\text{Also true, however: } Y \leq Y_1$$

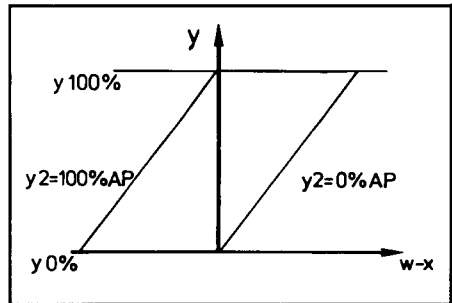

## 5 COMMISSIONING

### Parameter $Y_h$

In automatic mode, the display shows the current regulation ratio in %. The "DIGIT" key can be pressed to inhibit (OFF) or enable (ON) changeover to manual mode and this can be stored by pressing "ENTER". OFF means that the controller can be operated in automatic mode only. ON means that the controller can be switched to manual mode if feedback is switched on. To do this, press the Manual/Auto key. The LED for manual mode will light up. Re-select the parameter  $y_h$  with the "BACKSTEP" key. The range of adjustment of the output signal in this case is 0...100% or -100...0...100% in the case of heat/cool controllers. Leave manual mode again by pressing the "Manual/Auto" button. If the display flashes, at least one other channel is still switched to manual.

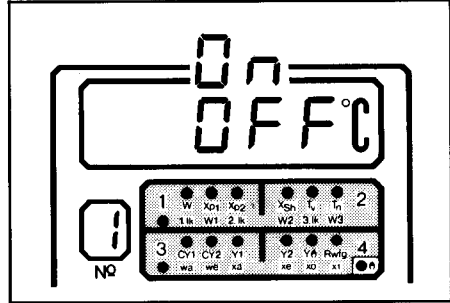

### Resistance transmitter $R_{wfg}$

Here a potentiometer variation range is entered. Total resistance must not be more than 400 Ohms! Resistance transmitters with a higher value can be adapted to the controller by inserting a shunt.  $R_A$  and  $R_E$  must be equal. However, differences can be compensated by using the parameters  $X_0$  and  $X_1$  (see page 42).

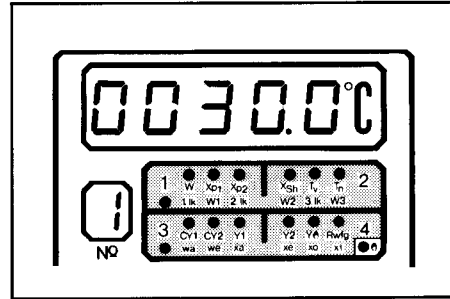

### Example:

wfg at: 500 Ohms..1000 Ohms..500 Ohms  
 Selected shunt: 400 Ohms  
 New total resistance:

$$R_{tot} = \frac{R_1 \cdot R_2}{R_1 + R_2} = \frac{2000 \text{ Ohms} \cdot 400 \text{ Ohms}}{2000 \text{ Ohms} + 400 \text{ Ohms}}$$

$$R_{tot} = 333 \frac{1}{3} \text{ Ohms}$$

Variation range =

$$\frac{1000 \text{ Ohms}}{5000 \text{ Ohms} + 1000 \text{ Ohms} + 500 \text{ Ohms}} \cdot R_{tot}$$

$$= \frac{333 \frac{1}{3}}{2} = 166 \frac{2}{3} \text{ Ohms}$$

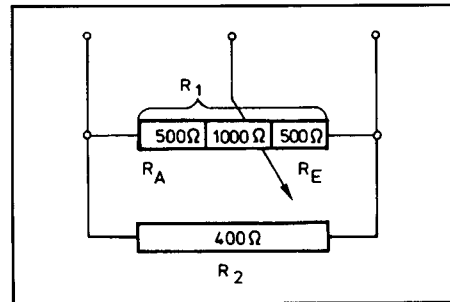

## 5 COMMISSIONING

### Limit-comparator(s)

In this controller, depending on the version, a maximum of 4 limit comparators can be incorporated (max. 3 limit comparators per channel). The corresponding relays are designated  $X_{k5}$ ,  $X_{k6}$ ,  $X_{k7}$  and  $X_{k8}$ . The desired limit comparator function Ik1...8 can be set from the front, via the keyboard. The next two pages describe the functions in detail.

LED 1.Ik of the first limit comparator lights up. A second LED, on the left in the information field, indicates that second-level data is now being entered. The display shows 0001, i.e. limit comparator function Ik1 is as set in the factory. The "UP" key can be used to enter the desired function Ik1...8. Pressing the "Enter" key confirms the limit comparator function in the program memory.

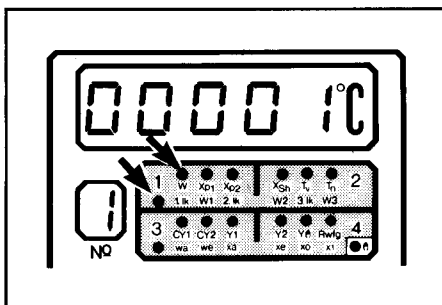

Now the flashing LED W1 indicates that the setpoint for the first limit comparator must be entered. The range of settings is  $\pm 9999$  digits. Ik1 and Ik2 set the window width and Ik3...6 the contact spacing for the controller setpoint. Ik7 and Ik8 allow the setpoint to be moved over the entire control range independently of the controller setpoint.

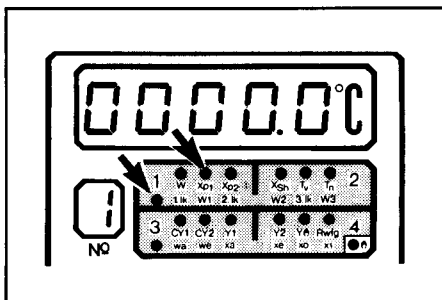

This program input is also terminated by pressing the "Enter" key.

If the 2nd (2.Ik) and third (3.Ik) limit comparators are fitted, proceed as with the first limit comparator.

# 5 COMMISSIONING

1

## Limit comparator "lk1"

The relay energizes when the actual value is within the set window and de-energizes when the actual value is outside the window.

Adjustable window width:  $\pm 9999$  digits

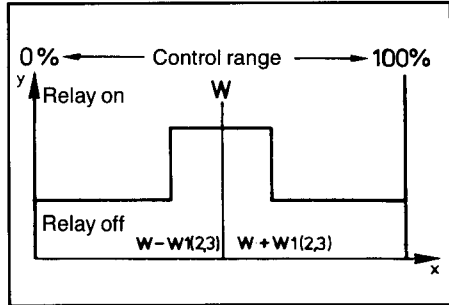

2

"lk2" as 1

but inverted relay function

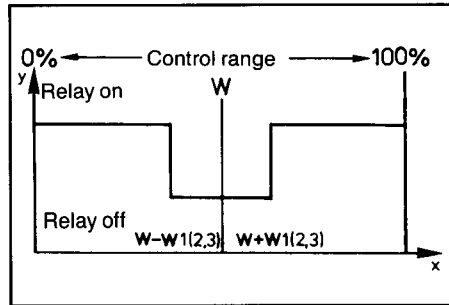

3

## Lower limit condition signalling "lk3" only

Function: relay energizes when actual value  $<$  limit value.

Adjustable contact gap:  $\pm 9999$  digits

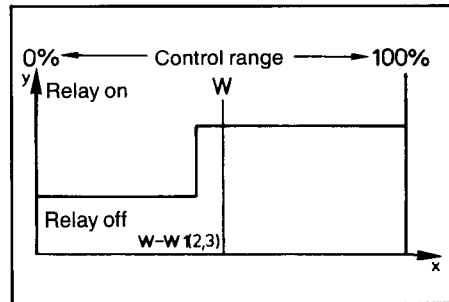

4

"lk4" as 3

but inverted relay function

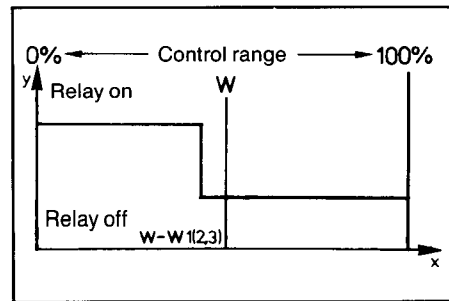

# 5 COMMISSIONING

5

**Upper limit condition signalling "Ik5" only**

Function: relay de-energizes when actual value > limit value

Adjustable contact spacing:  $\pm 9999$  digits

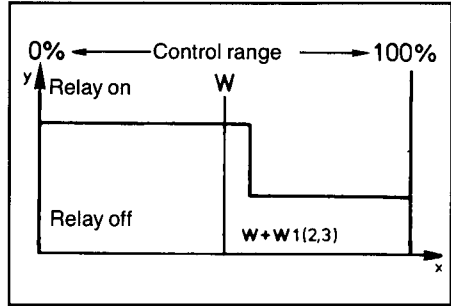

6

"Ik6" as 5

but inverted relay function

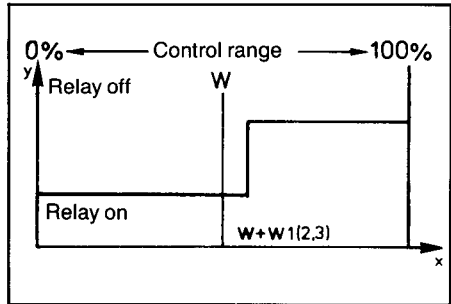

7

**"Ik7" adjustable over entire control range**

Function: relay energizes when actual value > limit value

Range of adjustment:  $\pm 9999$  digits

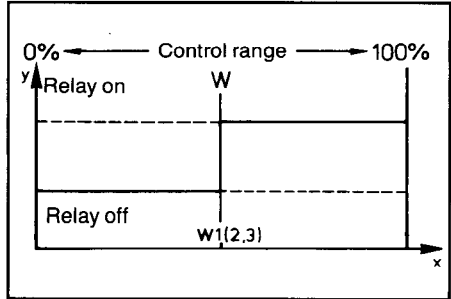

8

"Ik8" as 9

but inverted relay function

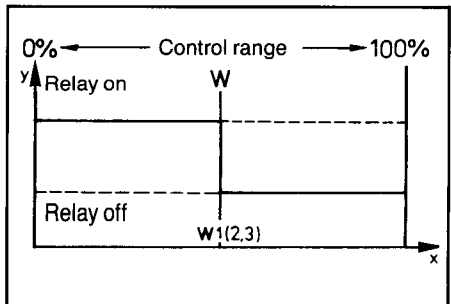

## 5 COMMISSIONING

### Setting setpoint limitation wa, we

The range of measurement depends on the selected input circuit. Within this range we and wa may be set as required.

wa = start of setpoint

we = end of setpoint

However, the following applies:

we  $\geq$  wa.

### Example:

Factory setting for control range:

-200.0...+850.0°C, Pt 100

Desired control range:

+200.0...+600.0°C, Pt 100

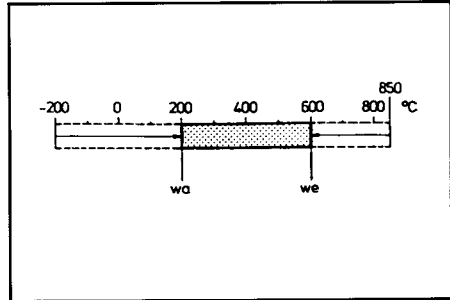

### Entry of start of setpoint wa

The display shows the start of the control range -200.0°C and the LED wa is lit. The low-order position flashes. Press the "DIGIT" key until the minus sign flashes and remove it with the "UP" key. Record the new start of setpoint in memory by pressing the "ENTER" key.

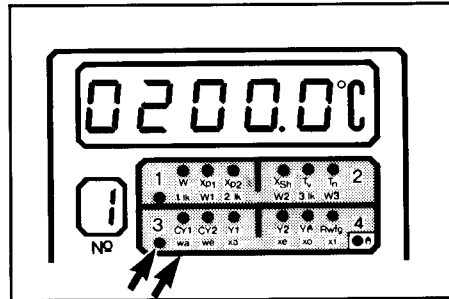

### Entry of end of setpoint we

The display shows the value for the end of the control range, 850.0°C. LED we lights up. The low-order position flashes. Use the "DIGIT" and "UP" keys to set the new value for the end of the control range and confirm by pressing "ENTER".

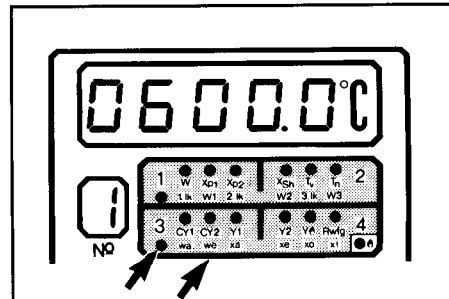

## 5 COMMISSIONING

### Measurement range limits $X_a$ and $X_e$

for current, voltage or resistance transmitter input:

A display range is assigned to the measurement input "unit signal" by means of these parameters.

$X_a$  = entry of initial actual value at start of measurement range

$X_e$  = entry of final actual value at end of measurement range

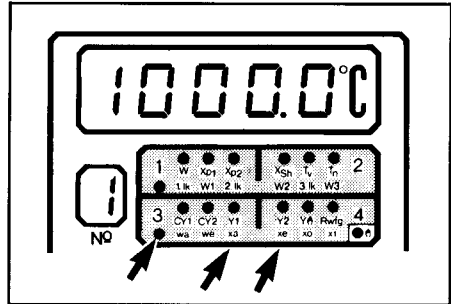

### Example:

Input: 0...20 mA.

Desired display range: 0...1000°C

Entry:  $X_a = 0$  and  $X_e = 1000$ , i.e.

0 mA  $\cong$  0°C and 20 mA  $\cong$  1000°C

### Note:

If a non-linear probe table is set, the display is automatically linearised correctly.

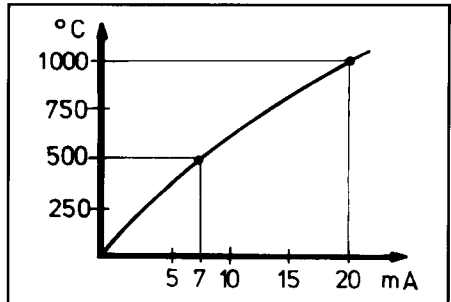

### $X0(1)$ = Correction of actual value display

If there is a difference between the controller display and another actual value indicator because of probe inaccuracies or line resistor effects, the difference can be eliminated by additional programming.

Possible incorrect displays:

$X_0$  = incorrect display of actual value at start of control range

The display is in the vicinity of the ambient temperature.

Correction:

The desired actual value, corresponding to the instantaneous measured value is entered in memory location  $X_0$ . The controller corrects its measurement by a constant  $X$  value, so that the desired value is displayed for this measured value.

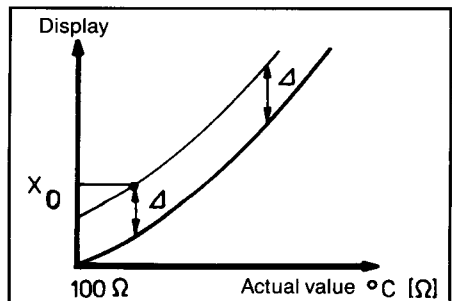

## 5 COMMISSIONING

### X1 = Correction of actual value display at end of control range

The display is in the vicinity of the end of the measurement range:

Correction:

The desired actual value, corresponding to the instantaneous measured value, is entered in memory location X1. The controller corrects its measurement by interpolation, so that at points X0 and X1 the controller displays the corrected values. These corrections may be repeated as often as required.

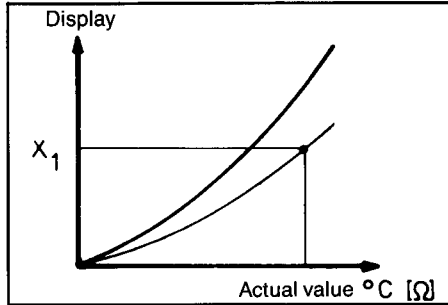

### Example:

1st measurement: 0°C  
 Desired display: 5°C  
 2nd measurement: 350°C  
 Desired display: 340°C

Correction:

Input for 1st measurement: X0 = 5°C  
 and for 2nd measurement: X1 = 340°C

All intermediate values are corrected.

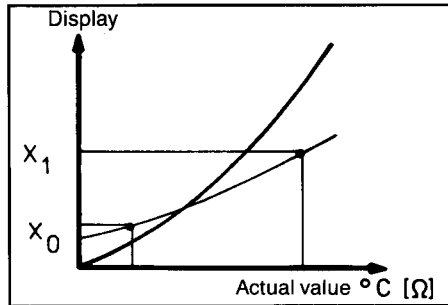

— Standard display  
 - - - required display

If X0 = X1 or X1 = 0 are entered, the unit reverts to the factory calibration constants. This setting is indicated by error message Er 2; this can be cleared by pressing the "STEP" or "BACKSTEP" keys.

## 5 COMMISSIONING

### 5.3 Monitoring entered data

The controller switches to programming mode when the "Pgm" key is pressed. The setpoint  $w$  is displayed.

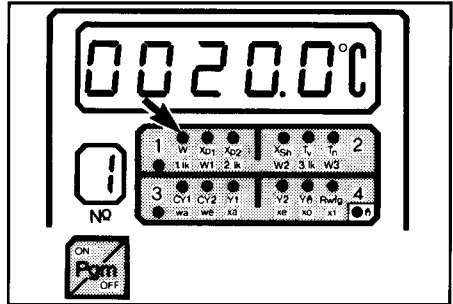

All entered data items can be displayed consecutively by pressing the "STEP" and "BACKSTEP" keys.

The other channels 2... max. 4 can be selected by pressing the "CHANNEL" key. The controller leaves programming mode when the "Pgm" key is pressed.

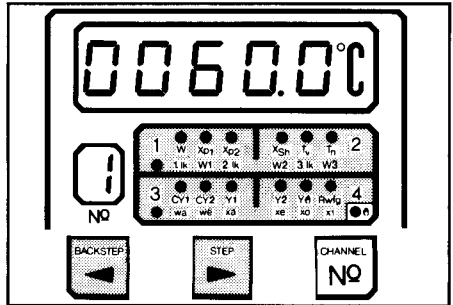

### 5.4 Data correction

Parameters to be corrected are overwritten using the "DIGIT" and "UP" keys, as for data entry; they are accepted into the program memory when "ENTER" is pressed. Then leave programming mode by pressing "Pgm".

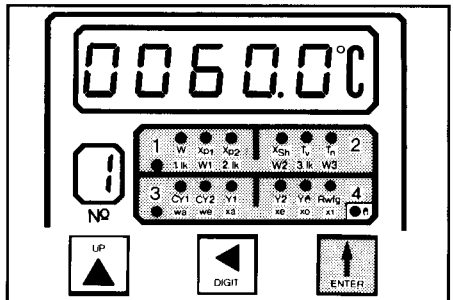

## 6 CONTROL STATION

### 6.1 Automatic mode

The control station is not in service; the controller is acting on the controlled system. Switching to manual mode can be inhibited in automatic mode to provide protection from incorrect operation. Manual operation is possible only if feedback is switched on.

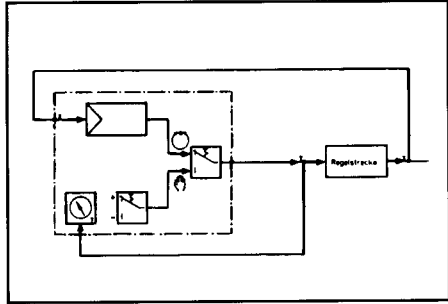

### 6.2 Manual mode

#### Automatic/manual switching

The selected channel can be smoothly switched to manual mode by pressing the "Manual/Auto" key, as long as it is not inhibited by parameter Y (see Data Entry, section 5.2). The LED for manual operation lights up. In manual mode, the instantaneous controller output signal is stored and continuously output. The output value can be changed via parameter Y as follows:

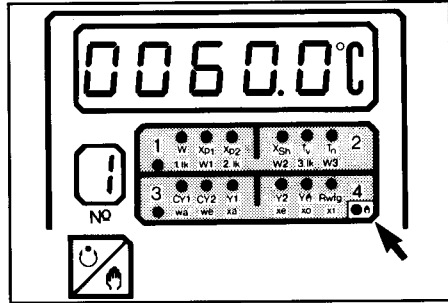

Press "Pgm" key. Use "STEP" or "BACKSTEP" keys to select parameter Y: the low-order position will flash. Use the "UP", "DIGIT", and "ENTER" keys to enter the desired output signal. Press the "Pgm" key.

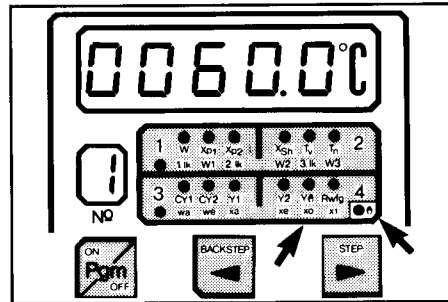

#### Manual/auto switching

It is possible to switch back to automatic mode at any time by pressing the "Manual/auto" key. If the manual mode display goes out, all channels are switched to automatic. If the display flashes, at least one channel is still in manual mode. Press "CHANNEL" key until the display stops flashing and the LED for manual mode lights up.

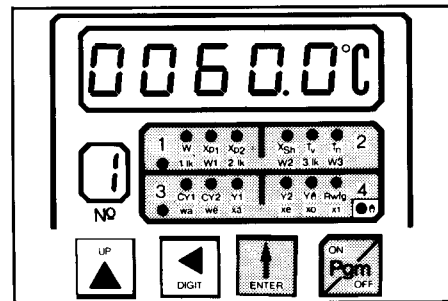

## 7 INTERFACE

A V.24 (RS 232 C) or TTY interface can be fitted (or retrofitted) to the DICON Z. It can drive printers or communicate with higher-level data systems. The interface is not activated when the controller is in programming mode.

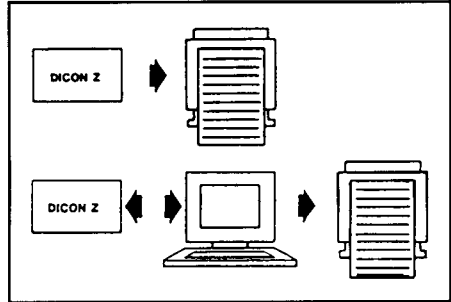

### 7.1 Handshake lines

CTS

Input (clear to send)

LOW signal inhibits transmitter

RTS

Output (request to send)

RTS is LOW when the controller is not ready to receive further data.

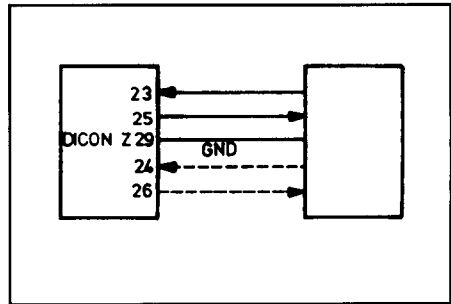

### 7.2 Data lines

$\overline{\text{RxD}}$

Input (receive data)

$\overline{\text{TxD}}$

Output (transmit data)

### 7.3 Transmission specification

The transmission rate is set as standard to 9600 baud. The baud rate and data format can be changed by means of internal straps (see section 3.5).

# 7 INTERFACE

## 7.4 Transmission syntax

### Description of parameters

**X**  
Actual value (the actual value can only be interrogated)

**W**  
Setpoint

**X<sub>P1</sub>**  
Proportional band (in a heat/cool controller: P band of the "heating contact").  
Extra function: OFF  
Explanation: OFF means that the "heating contact" works without feedback.

**X<sub>P2</sub>**  
Proportional band of the "cooling contact" for a heat/cool controller.  
Extra function: OFF  
Explanation: OFF means that the "cooling contact" works without feedback.

**X<sub>SH</sub>**  
Contact spacing in the case of heat/cool controller and modulating controller.

**T<sub>V</sub>**  
Derivative action time constant  
Extra function: OFF  
Explanation: OFF means

1. In a single-point or heat/cool controller: changeover from PD/PID structure to PID structure.
2. In a modulating controller: changeover from PID structure to PI structure (ON/OFF).
3. In a proportional controller: changeover from PID structure to PI structure or from PD structure to P structure.

**T<sub>N</sub>**  
Reset time  
Except for heat/cool modulating controller  
Extra function: OFF  
Explanation: OFF means

1. In a single-point or heat/cool controller: changeover from PD/PID structure to PD structure.
2. In a proportional controller: changeover from PID structure to PD structure or from PI structure to P structure.

**C<sub>Y1</sub>**  
Minimum period duration (maximum frequency) of "heating contact" (complied with only if feedback is switched on and for single-point and heat/cool controller function).

**X<sub>D1</sub>**  
Switching differential of the "heating contact" (complied with only if feedback is switched off and for single-point, heat/cool and modulating controller function).

**C<sub>Y2</sub>**  
Minimum period duration (maximum frequency) of "cooling contact" (complied with only if feedback is switched on and for heat/cool controller function).

**X<sub>D2</sub>**  
Switching differential of the "cooling contact" (complied with only if feedback is switched off and for single-point controller function).

**Y<sub>1</sub>**  
Maximum output signal of "heating contact" (complied with only if feedback is switched on).  
For heat/cool modulating controller with control station:  
Limitation of the maximum regulation ratio.

**Y<sub>2</sub>**  
Maximum output signal of "cooling contact" (complied with only if feedback is switched on).  
For heat/cool modulating controller with control station:  
Limitation of the minimum regulation ratio.  
For proportional controller:  
moving the working point  
 $Y_{OUT} = Y_2$  in the case of P structure and  $X = w$ .

**Y<sub>OUT</sub>**  
Indication of output signal.  
For single-point controller: 0...100%.  
For heat/cool controller: -100...0...100%.  
The output signal can only be interrogated.

## 7 INTERFACE

### HANDM

Auto/manual or manual/auto changeover (ON/OFF). This changeover is possible only when  $Y_H = ON$ . Manual mode is possible only if feedback is on. In auto mode, manual operation can be inhibited ( $Y_h = OFF$ ) or enabled ( $Y_h = ON$ ).

$$Y_H = Y \text{ (M)}$$

Output signal in manual mode 0...100% or -100...0...100%. Since the value stored in "Y<sub>OUT</sub>" is transferred to "Y<sub>H</sub>" on changeover, the value "Y<sub>H</sub>" cannot reasonably be programmed until the controller has switched to manual mode. In auto mode, this parameter has the function ON/OFF. OFF means that the unit cannot be switched to manual mode.

### R<sub>WFG</sub>

Parameter which is employed only if there a "wfg" input (input of potentiometer variation range).

### LK1 (2, 3)

Programming of lk function of 1st (2nd, 3rd) limit comparator (lk1...8).

### W<sub>LK1 (2, 3)</sub>

Specification of setpoint of 1st (2nd, 3rd) limit comparator.

### W<sub>A</sub>

Setpoint limitation, start of setpoint (setpoint entries which are below this limit are not accepted).

### W<sub>E</sub>

Setpoint limitation, end of setpoint (setpoint entries which exceed this limit are not accepted).

### X<sub>A</sub>

This parameter is accepted only in the case of a current or resistance transmitter input. Function: entry of initial actual value at start of measurement range.

### X<sub>E</sub>

This parameter is accepted only in the case of current or resistance transmitter input. Function: entry of final actual value at start of measurement range.

### X<sub>0</sub>

Cannot be programmed across the interface.

### X<sub>1</sub>

Cannot be programmed across the interface.

### Relays

Output of relay position only

| BIT 7           | 6               | 5               | 4               | 3               | 2               | 1               | 0               |
|-----------------|-----------------|-----------------|-----------------|-----------------|-----------------|-----------------|-----------------|
| X <sub>k8</sub> | X <sub>k7</sub> | X <sub>k6</sub> | X <sub>k5</sub> | X <sub>k4</sub> | X <sub>k3</sub> | X <sub>k2</sub> | X <sub>k1</sub> |

The representation is binary-coded (1 byte). Parameters not used in the respective controller function can be programmed and interrogated, but are not implemented.

### Description of parameters taking channel number into account

The channel number must be added immediately after the parameter designation.

Example: X<sub>p13</sub>

This means: X<sub>p</sub> value of "heating contact" for channel 3

### Interrogating set control parameters

Syntax (enter with no spaces):

The controller responds with the following syntax:

Value

Value:

1. Numerical value

The value is a five-digit decimal number (preceded by the minus sign in the case of a negative value). Leading zeros are output; the decimal point is not output.

# 7 INTERFACE

## 2. Text

With various parameters, there is the option of entering the text "OFF" or "ON" instead of a five-digit value. An "OFF" setting, simultaneous in the case of  $T_v$  and  $T_n$ , is permissible only with a proportional controller.

1st example:

Entry (enter with no spaces):

? XP13 CR LF

Response:

00124 CR LF

2nd example:

Entry (enter with no spaces):

? X023 CR LF

Response:

OFF CR LF

Overrange or underrange is transferred as 19999 or -19999 respectively.

### Programming the parameters

Syntax:

Parameter Space Value CR LF

The controller responds with the following syntax:

Response:

OK CR LF

Value:

as for interrogation of set parameters

1st example:

XP13 00332 CR LF

Response:

OK CR LF

2nd example:

Entry:

HANDM1 ON CR LF

Response:

OK CR LF

Behaviour in the event of data transmission errors:

The controller has an input buffer of 20 characters. If any characters which do not comply with the syntax are read, it responds as follows, after the 20th character at the latest:

SN CR LF

SN = Syntax error

Transferred characters must always be terminated by CR and LF, otherwise they are not processed by the controller.

If an incorrect parameter name is entered, the controller responds, after

CR LF, with SN CR LF

(syntax error).

If a value is entered which is outside the value range, it responds after

CR and LF with ? CR LF.

### Protecting the transmission path

To prevent the transmission of incorrect data, the programmed data should be interrogated once more and compared.

## 8 DATA BUFFERING IN THE EVENT OF POWER FAILURE

The entered values are stored with the aid of a lithium battery.  
The lifetime of this battery is 3..5 years.  
If the battery voltage falls below the voltage required for data buffering, the display shows...ER 4.

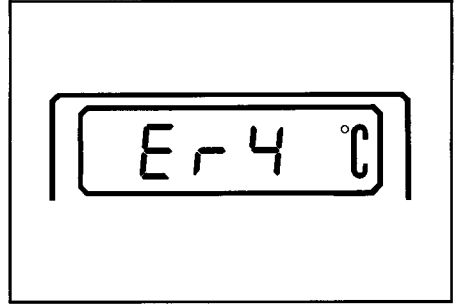

### 8.1 Changing the battery

After loosening the cross-head screw, the controller unit can be pulled out from the housing. The Li battery is located on the CPU board. Before changing the battery, remove the locating plate and pull out the input card.

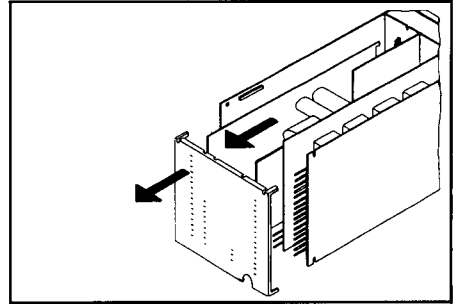

Pull the old battery off the terminal strip.  
Insert new battery.

The illustration opposite shows the underside of the controller.

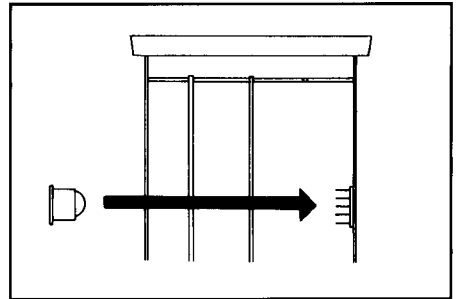

After replacing the battery, re-insert the input card and replace the locating plate. Push the controller unit into the housing and secure with the cross-head screw. The unit is now ready for use again.

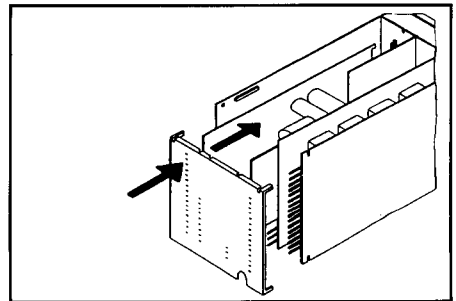

## 9 OPTIMISATION

---

(Adapting control parameters  $X_p$ ,  $T_n$  and  $T_v$  to the controlled plant)

The optimum setting means:

1. Good start-up behaviour, i.e. a start-up curve which is as steep as possible without excessive overshoot.
2. Good fault behaviour and command behaviour, i. e. when an external fault occurs or when the command variable is modified, rapid equilibration without oscillation must be guaranteed.

When accurate characteristics of the controlled system are available, the control parameters for a specific working point can be determined using extensive mathematical calculations. However, since the exact characteristic data on controlled plant is seldom available in practice, tried and tested practical adjustment criteria have been developed experimentally.

Here too, in general, the assumed conditions (e.g. erratic changes in the disturbance variable or command variable at the entry to the controlled plant) are only approximately correct, so the results obtained must be considered merely as a guide.

For the practising engineer it is advisable to record the progression of the controlled variable experimentally and to find the most favourable setting by stepped changes to one parameter at a time.

A basic setting for controllers with PID behaviour can be obtained from the procedure described below, depending on the established parameter values.

## 9.1 Oscillation method according to "ZIEGLER" and "NICHOLS"

This method is applicable to control loops which may become destabilised for short periods ( $T_g/T_u > 3$ ). The controller is first operated at the following settings:  $T_n$  set to  $P_d$  (in the case of a continuous controller with a P structure) and  $T_v$  set to minimum,  $X_{p1}$  or  $X_{p1}$  and  $X_{p2}$  respectively set to maximum. Then, by slowly reducing the P-band  $X_p$  (and therefore increasing control amplification), seek the limit of stability at which the controlled variable is subject to undamped oscillation at constant amplitude. From this we obtain:

- a) the set P-band  $X_{pk}$  (critical)
- b) the period of oscillation  $T_k$  (critical)

The optimal setting is:

$$X_p \approx 1.7 \cdot X_{pk} \quad T_n \approx 0.5 \cdot T_k$$

$$T_v = \frac{T_n}{4.5}$$

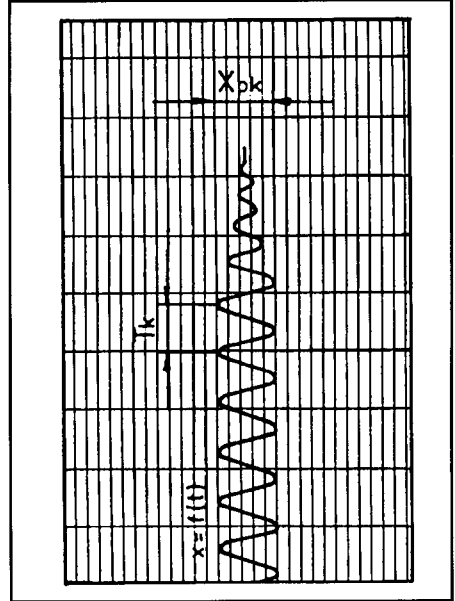

## 9.2 Adjustment according to controlled system characteristics

Not all control loops can be made unstable for short periods. The procedure is therefore based on the controlled plant data and controller data. Using the transfer function (correction or disturbance step function response), the values for

$K_s$  = Transfer transmission of the controlled plant

$$K_s = \frac{\Delta x}{\Delta y} = \frac{\text{change in output variable}}{\text{change in input variable}}$$

$T_u$  = delay time

$T_g$  = response time

From the ratio  $T_u/T_g$  it is possible to estimate the controllability of the controlled plant.

The following applies:

$T_u/T_g < 0.1$  – good controllability

$T_u/T_g = 0.1 \dots 0.3$  – still controllable

$T_u/T_g > 0.3$  controllable with difficulty

## 9 OPTIMISATION

The step function response should be employed in the area of the working point (setpoint); at time  $t_0$  move the input variable of the controlled plant discretely within the regulating range  $Y_{hs}$  by an amount  $\Delta y$  (e.g. 10% of  $Y_{hs}$ ).

The result is a step function response with the values for  $x$ ,  $T_u$  and  $T_g$ .

The controller setting is then determined according to the rules of thumb for controlled systems with equalisation as follows:

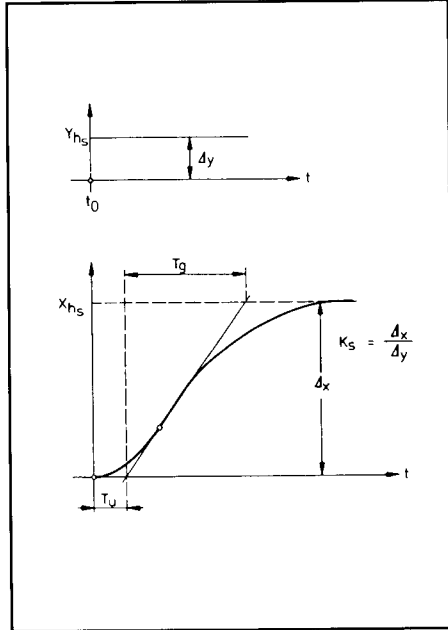

Optimisation according to CHIEN, HRONES and RESWICK

Aperiodic control process with shortest duration for optimisation of:

Command

$$X_p \approx 1.7 \cdot \frac{T_u}{T_g} \cdot K_s \cdot Y_{hs}$$

$$T_n \approx 1 \cdot T_g$$

$$T_v = \frac{T_n}{4.5}$$

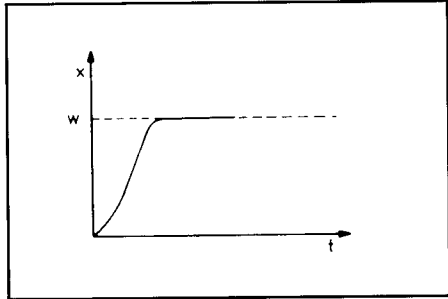

Disturbance

$$X_p \approx 1.05 \cdot \frac{T_u}{T_g} \cdot K_s \cdot Y_{hs}$$

$$T_n \approx 2.4 \cdot T_u$$

$$T_v = \frac{T_n}{4.5}$$

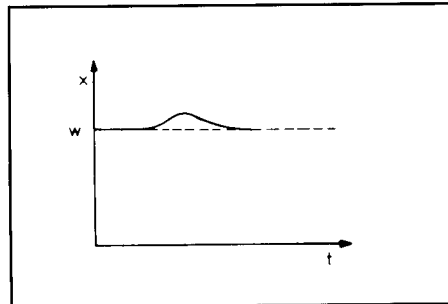

## 9 OPTIMISATION

Control process with 20% overshoot and minimum duration of oscillation with optimisation for:

Command

$$X_p \approx 1.05 \cdot \frac{T_u}{T_g} \cdot K_S \cdot Y_{hs}$$

$$T_n \approx 1.35 \cdot T_g$$

$$T_v = \frac{T_n}{4.5}$$

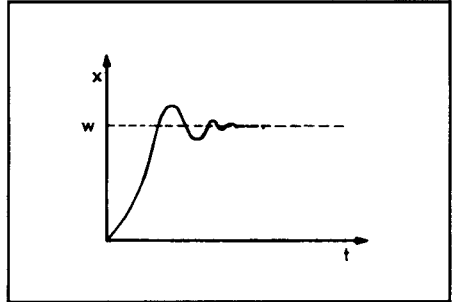

Disturbance

$$X_p \approx 0.83 \cdot \frac{T_u}{T_g} \cdot K_S \cdot Y_{hs}$$

$$T_n = 2 \cdot T_u$$

$$T_v = \frac{T_n}{4.5}$$

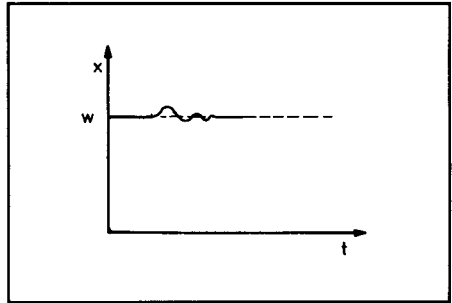

Example: electrically heated oven as controlled plant

Input variable is electrical power in kW, e.g. 0..10 kW. Output variable is temperature in °C, e.g. 20..320°C. The controller used is a single-point controller with a control range of 0..400°C. The working point (setpoint) must be 200°C. From this information we obtain the following values:

$$Y_{hs} = 10 \text{ kW} - 0 \text{ kW} = 10 \text{ kW}$$

$$X_{hs} = 320^\circ\text{C} - 20^\circ\text{C} = 300^\circ\text{C}$$

In order to record the step function response, the power at the input to the oven is increased discretely from e.g. 3 kW to 8 kW.

In the case of linear dependence of input variable in relation to output variable, we obtain a step function response from 110°C to 260°C.

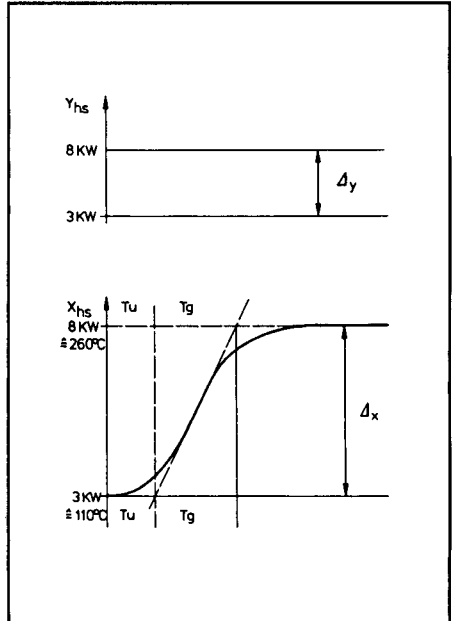

## 9 OPTIMISATION

---

$$\Delta x = 150^{\circ}\text{C}$$

$$\Delta y = 5 \text{ kW}$$

$$K_s = \frac{\Delta x}{\Delta y} = \frac{150^{\circ}\text{C}}{5 \text{ kW}} = 30 \frac{\text{ }^{\circ}\text{C}}{\text{ kW}}$$

Disturbance optimisation for 20% overshoot.

$$T_u = 1 \text{ min}$$

$$T_g = 5 \text{ min}$$

$$X_p = 0.83 \cdot K_s \cdot \frac{T_u}{T_g} \cdot Y_{hs}$$

$$X_p = 0.83 \cdot 30 \frac{\text{ }^{\circ}\text{C}}{\text{ kW}} \cdot \frac{1 \text{ min}}{5 \text{ min}} \cdot 10 \text{ kW}$$

$$X_p = 49.8^{\circ}\text{C}$$

$$T_n = 2 \cdot T_u = 2 \text{ min}$$

$$T_v = \frac{T_n}{4.5} = 27 \text{ s}$$

## 9 OPTIMISATION

If a stepped power lead-in is not possible, the step function response is recorded for a 100% power increase. Since the controlled plant will not always allow this for technical reasons, there is one other possibility of determining controller parameters. In this instance the rise rate of the step function response is evaluated.

$X_{\max}$  = maximum value of controlled system

$$V_{\max} = \frac{\Delta x}{\Delta t}$$

With reference to the above example, the following values are obtained for PID controllers:

$$\Delta t = 3 \text{ min}$$

$$\Delta x = 90^\circ\text{C} \quad V_{\max} = \frac{\Delta x}{\Delta t} = \frac{90^\circ\text{C}}{3 \text{ min}} = 30 \frac{^\circ\text{C}}{\text{min}}$$

$$X_p = 0.83 \cdot V_{\max} \cdot T_u$$

$$X_p = 0.83 \cdot 30 \frac{^\circ\text{C}}{\text{min}} \cdot 2 \text{ min}$$

$$X_p = 49.8^\circ\text{C}$$

$$T_n = 2 \cdot T_u = 2 \text{ min}$$

$$T_v = \frac{T_n}{4.5} = 27 \text{ s}$$

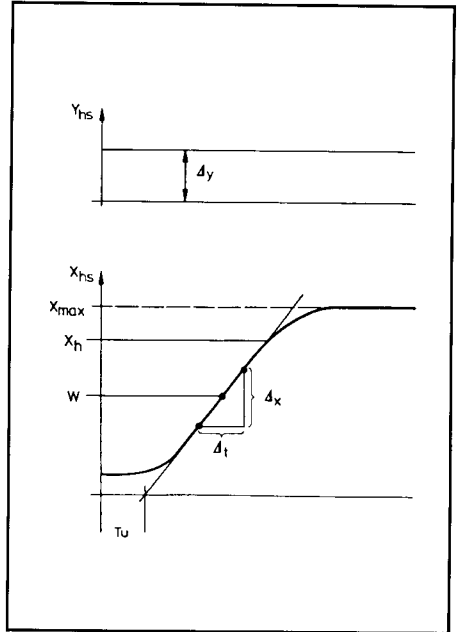

### Rule of thumb for parameter setting

| Controller structure | Setting   |
|----------------------|---|
| P                    | $X_p \approx V_{\max} \cdot T_u$ ( $^\circ\text{C}$ )   |
| PI                   | $X_p \approx 1.2 \cdot V_{\max} \cdot T_u$ ( $^\circ\text{C}$ )   |
| PD                   | $X_p \approx 0.83 \cdot V_{\max} \cdot T_u$ ( $^\circ\text{C}$ )<br>$T_v \approx 0.25 \cdot T_u$ (min)                                  |
| PID                  | $X_p \approx 0.83 \cdot V_{\max} \cdot T_u$ ( $^\circ\text{C}$ )<br>$T_n \approx 2 \cdot T_u$ (min)<br>$T_v \approx T_n/4.5$ (min)      |
| PD/PID               | $X_p \approx 0.4 \cdot V_{\max} \cdot T_u$ ( $^\circ\text{C}$ )<br>$T_n \approx 2 \cdot T_u$ (min)<br>$T_v \approx 0.4 \cdot T_u$ (min) |

## 9 OPTIMISATION

### 9.3 Monitoring optimisation

The optimal adaptation of the controller to the controlled plant can be monitored by recording a start-up procedure with the control loop closed.

The following diagrams give hints on possible incorrect settings and corrections.

$T_v/T_n$  too small

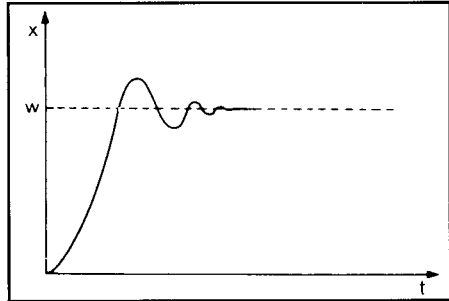

$T_v/T_n$  too big

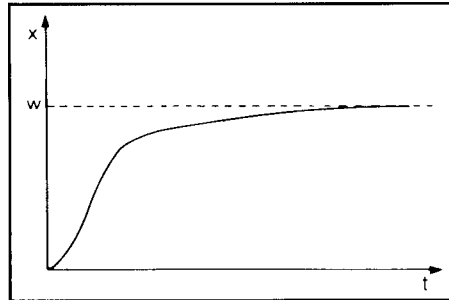

$X_p$  too big

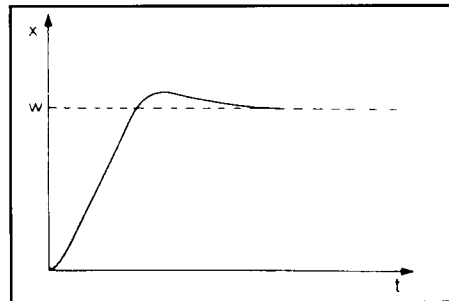

## 9 OPTIMISATION

---

$X_p$  too small

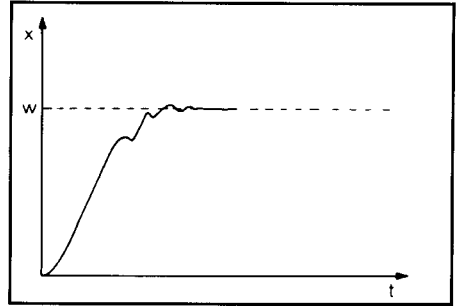

Optimal setting

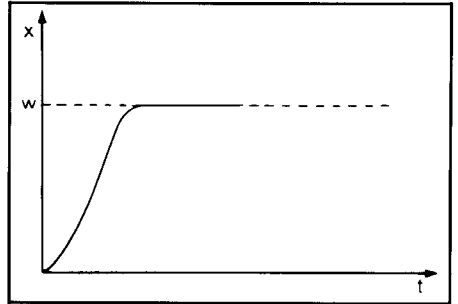

It is apparent that both a greater  $X_p$  and a greater  $T_n$  give a more stable, neutral type of regulation.

If  $X_p$  or  $T_n$  are smaller, a less damped type of regulation behaviour occurs.

## 10 MAINTENANCE AND FAULTS

---

The controllers are maintenance-free. In the event of a fault, please return the unit to the supplier, specifying the precise nature of the fault.

The personnel in our external sales offices, branches and agencies are at your disposal at any time for any advice or services you may require.