

Interface description for the programmers **JUMO DICON P and JUMO DICON PR**

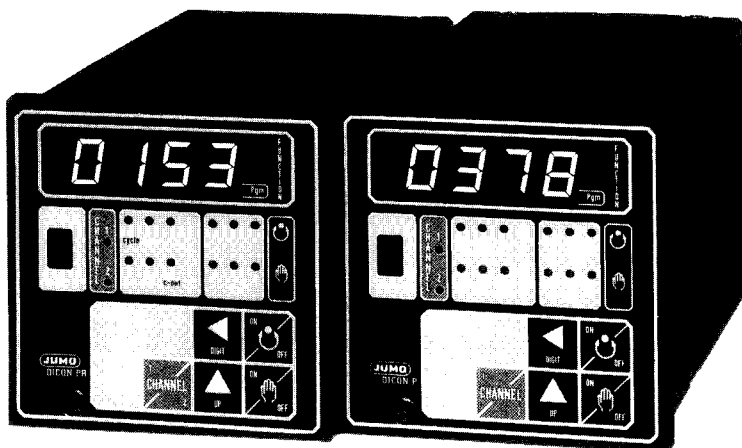

D 95.620.2/630.2

11.92/V 74696

Operating Instructions

CONTENTS

	Page
7	ERROR HANDLING 29
7.1.	Error handling and error report 29
7.2	Error read-out 30
7.3	Special features in the error handling in the case of RS 422/485 31
7.4	Check list - error treatment and remedies 31
8	WIRING RECOMMENDATIONS 32
9	WIRING DIAGRAMS 33
9.1	Connection PC - RS232 33
9.2	Connection PC - RS422 34
9.3	Connection PC - RS485 35
9.4	Connection JUMO DICON P/PR - JUMO DICON Z in JUMO-DICON Mode 36
10	APPENDIX 37
10.1	ASCII Table 37
10.2	Connections at the interface on the JUMO DICON P/PR 38
10.3	Pin connections 39
10.3.1	RS232 interface 39
10.3.2	RS422/485 interface 42
10.4	Overview of permitted levels and line lengths 43

NOTE

All necessary settings and, where appropriate, alterations are described in these Operating Instructions. If, however, any difficulties should arise during start-up, you are asked not carry out any manipulation on the instrument which is not permitted.

- You could endanger your rights under the instrument warranty.

Please contact the nearest office or the main factory.

CONTENTS

Page

1	INTRODUCTION	1
2	ADJUSTING THE INTERFACE PARAMETERS	2
2.1	Adjusting the interface parameters on the RS232 (V24) and TTY	2
2.2	Adjusting the interface parameters on the RS 422/485	3
2.3	Setting the device address on the RS 422/485	4
3	INPUT AND OUTPUT SYNTAX	5
3.1	General syntax description	5
3.2	Syntax for JUMO DICON P	6
3.3	Program run	9
3.3.1	Selecting and starting program	9
3.3.2	Stopping a program	9
3.3.3	Reading out Hand mode	10
3.3.4	Setting setpoint and timing switches in Hand mode	10
3.3.5	Switching off Hand mode	10
3.3.6	Changing channel status	11
3.3.7	Reading out channel status	11
3.3.8	Starting the program at any point	12
3.4	Programming	13
3.4.1	Setting values for one section	13
3.4.2	Reading out values for one section	13
3.4.3	Setting all values of a section for a timing contact	14
3.4.4	Reading out all values of a section for a timing contact	14
3.4.5	Inserting or deleting a section in the program	15
3.4.6	Inserting or deleting a section in the timing contact program	15
3.5	Special functions	16
3.5.1	Erasing a program	16
3.5.2	Clearing the program memory	16
3.5.3	Reading out the configuration table	16
3.5.4	Reading out checksum	17
3.5.5	Reading out errors	17
3.6	Additional syntax for the DICON PR	18
3.6.1	Changing the controller parameters	18
3.6.2	Reading out controller parameters	19
3.7	Example for syntax on RS422/485	19
3.8	Timing of transmission protocol	19
4	SPECIAL FEATURES OF THE INTERFACES	20
4.1	EOT command	20
4.2	Handshake on the RS232	20
4.3	Bus operation with the RS422/485	21
4.4	Isolation	22
5	JUMO DICON MODE	23
5.1	General description	23
5.2	Adjusting the JUMO DICON mode	23
5.3	Transmission protocol	24
5.4	Significance of the decimal place	25
5.5	Timed processing of setpoint transmission in the JUMO DICON mode	25
5.6	Error handling in the JUMO DICON mode	25
6	SPECIAL FEATURES OF THE JUMO DICON P	26
6.1	Printer operation with the JUMO DICON P	26
6.1.1	Protocol print-out	26
6.1.2	Printing out of programs	27
6.1.3	Handshake and device addresses	27
6.2	Copying of prgrams	28

1 INTRODUCTION

The serial interface permits convenient operation of the programmer/program controller via a PC. In the case of the RS 422/485 up to 31 devices can be operated from a central command and monitoring point.

There are several standards for digital interfaces which are designed for different applications. The main criteria are circuit complexity, transmission speed and sensitivity to external interference as well as maximum transmission distance and bus capability.

Certain internal features of the JUMO DICON P/PR, such as watchdog circuit and special software routines, ensure a maximum of operating and transmission security.

These internal measures should be supported by appropriate wiring, observation of the notes in these Operating Instructions, as well as optimisation of the application software in order to ensure maximum functional security of the complete installation.

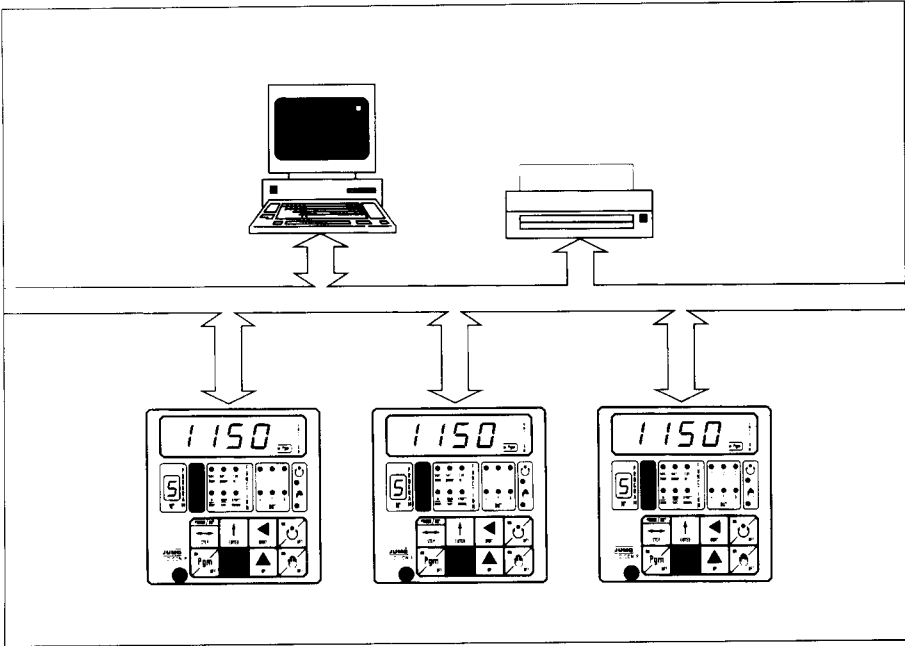

2 ADJUSTING THE INTERFACE PARAMETERS

2.1 Adjusting the interface parameters on the RS232 (V24) and TTY

After releasing the Philips head screw the chassis can be withdrawn from the housing. Data format and transmission speed can be altered through the jumpers (Br) 50 - 61 on the interface board.

- x = closed
- o = open
-  = standard setting

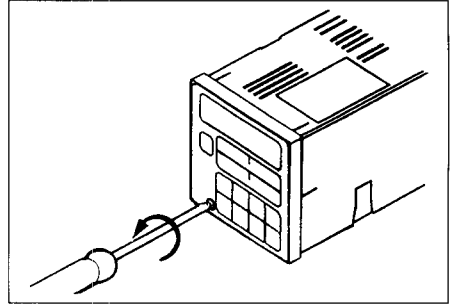

Data format

	o	x
Br. 53	parity odd	parity even
Br. 54	no parity odd	parity bit
Br. 55	1 stop bit	2 stop bits
Br. 56	8 data bits	7 data bits
Br. 57	terminal off	terminal on (echo)

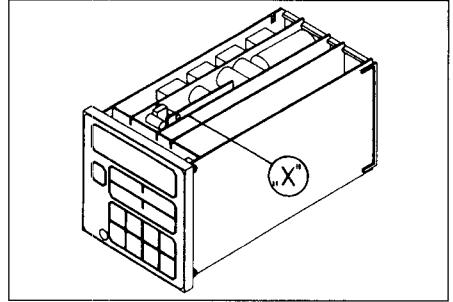

Transmission speed

Br. 52	Br. 51	Br. 50	baud rate
o	o	o	9600
o	o	x	4800
o	x	o	2400
o	x	x	1200
x	o	o	600
x	o	x	300
x	x	o	150
x	x	x	75

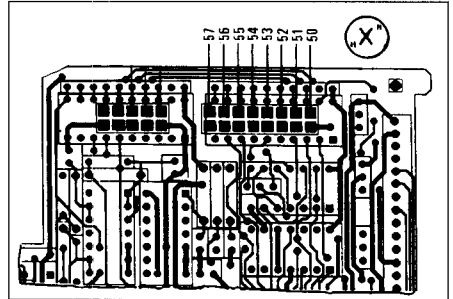

2 ADJUSTING THE INTERFACE PARAMETERS

2.2 Adjusting the interface parameters on the RS 422/485

After releasing the Philips head screw the chassis can be withdrawn from the housing.

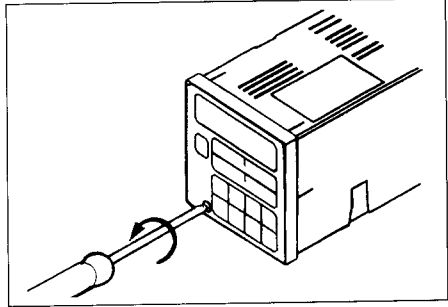

Data format and transmission speed can be altered through the jumpers (Br) 53 - 61 and the switches S6 - S8.

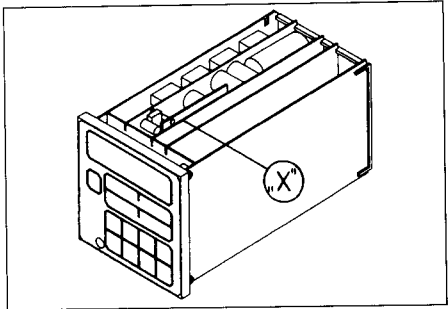

- x = closed
- o = open
- = standard setting

Data format

	o	x
Br. 53	parity odd	parity even
Br. 54	no parity odd	parity bit
Br. 55	1 stop bit	2 stop bits
Br. 56	8 data bits	7 data bits
Br. 57	terminal off	terminal on (echo)*

* not on RS485

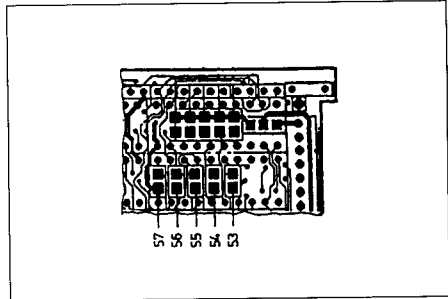

Transmission speed

S6	S7	S8	baud rate
o	o	o	9600
o	o	x	4800
o	x	o	2400
o	x	x	1200
x	o	o	600
x	o	x	300
x	x	o	150
x	x	x	75

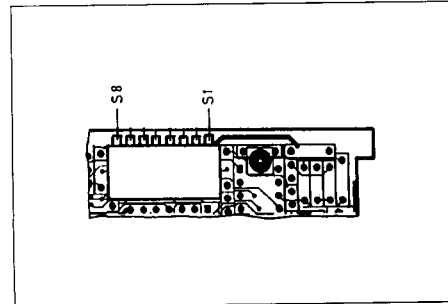

2 ADJUSTING THE INTERFACE PARAMETERS

2.3 Setting the device address on the RS 422/485

After releasing the Philips head screw the chassis can be withdrawn from the housing.

x = closed
o = open
□ = standard setting

The device addresses are set with DIL switches as follows:

S1	S2	S3	S4	S5	device address
o	o	o	o	o	0
o	o	o	o	x	1
o	o	o	x	o	2
o	o	o	x	x	3
o	o	x	o	o	4
o	o	x	o	x	5
o	o	x	x	o	6
o	o	x	x	x	7
o	x	o	o	o	8
o	x	o	o	x	9
o	x	o	x	o	10
o	x	o	x	x	11
o	x	x	o	o	12
o	x	x	o	x	13
o	x	x	x	o	14
o	x	x	x	x	15
x	o	o	o	o	16
x	o	o	o	x	17
x	o	o	x	o	18
x	o	o	x	x	19
x	o	x	o	o	20
x	o	x	o	x	21
x	o	x	x	o	22
x	o	x	x	x	23
x	x	o	o	o	24
x	x	o	o	x	25
x	x	o	x	o	26
x	x	o	x	x	27
x	x	x	o	o	28
x	x	x	o	x	29
x	x	x	x	o	30
x	x	x	x	x	31

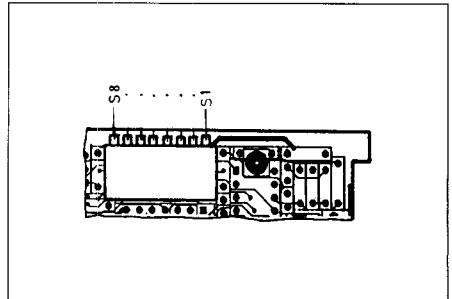
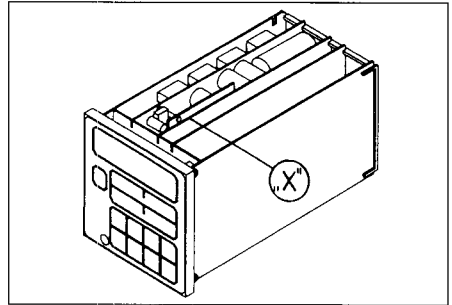
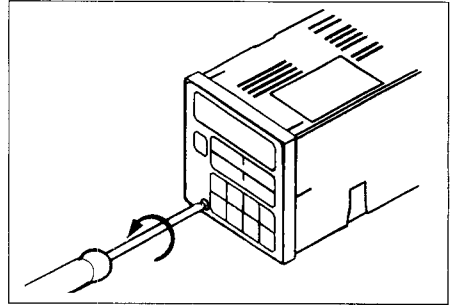

3 INPUT AND OUTPUT SYNTAX

3.1 General syntax description

Before any data transmission the input buffers of the devices should be cleared with 'EOT' in order to achieve a defined starting status.

All possible inputs via the keys can also be input through the interface.

The general syntax is as follows:

sending or requesting data from the programmer/program controller

[< * xx >] [< ? >] <command> <CHx > [<parameter 1 ... n >] <CR > [LF]

Response of programmer/program controller

[< * xx >] <response> <CR> <LF>

[]	= optional information
* xx	= 2-digit device number (RS422/485 only). To identify this number it is preceded by the code '*'. = sending '?' requests the values from the programmer/program controller
Command	= all valid commands for the particular instrument type
CHx	= indication of channel number (also on 1-channel instruments!)
Parameter	= all valid parameters for the particular instrument type
CR LF	= end identification of transmission

The syntax permits both upper case and lower case letters!

Response	= response of programmer/program controller
	'OK' for correct transmission and correct syntax or the requested value
	'SN' in case of faulty transmission or faulty syntax

3 INPUT AND OUTPUT SYNTAX

3.2 Syntax for JUMO DICON P

The individual commands and their responses are described below.

The meaning is as follows:

- [] the parameters in these bracket can, but need not be entered
- () one of the parameters in these brackets is permitted
- ⇒ response of programmer/program controller
- SN syntax error

Overview of the significance of the parameters and their permitted inputs:

Parameter	Description	No. of digits	Range	Notes
CH.	channel number	1	1...2	
NO..	program number	2	00..19	
SC..	section number	2	00..99	
W.....	setpoint	sign +4	-9999...+9999	depending on range*
H...'	(residual) section time/ start time	2'2	00'00...99'59	h'min
M...'	(residual) section time/ start time	2'2	00'00...99'59	min'sec
CY.....	repeats (cycle)	2:2	00:00...99:99 (CC)	(Sect. No.) : (No. of repeats) CC = continuous repeats
OUT.	relay number	1	1 6	6 = max.number
ZS.....	contact status of the relays OUT1...6	6	 000000...111111	only 0 and 1 possible
ON/OFF	on/off	/	/	status of the relays/hand op.

* Existing blank spaces can be filled up with 0s but need not.
Positive sign need not be input.

3 INPUT AND OUTPUT SYNTAX

Overview of the commands for JUMO DICON P and JUMO DICON PR

changing values	reading out values
PROGRAM RUN	
<p>Selecting and starting program: AUTO CHx NOxx [(H, M)xx'xx] <cr> [lf]</p> <p style="margin-left: 100px;">└─── delay time</p>	
<p>Stopping program: AUTO CHx OFF <cr> [lf]</p>	
<p>Setting W and ZS in Hand mode: HAND CHx ON [Wxxxxx] [ZSxxxxxx] <cr> [lf]</p>	
<p>Switching off Hand mode HAND CHx OFF <cr> [lf]</p>	<p>Reading out Hand mode: ? HAND CHx <cr> [lf]</p>
<p>Changing channel status CHx (Hand, Auto) <cr> [lf]</p>	<p>Reading out channel status ? CHx <cr> [lf]</p>
<p>Starting program at any point AUTO CHx NOxx SCxx [(H, M)xx'xx] <cr> [lf]</p> <p style="margin-left: 100px;">└─── residual section time</p> <p style="margin-left: 100px;">└─── section number</p>	
PROGRAMMING	
<p>Setting all values for one section: PROG CHx NOxx SCxx [Wxxxxx] [(H, M)xx'xx] [CYxx:xx] <cr> [lf]</p>	<p>Reading out all values for one section: ? PROG CHx NOxx SCxx <cr> [lf]</p>
<p>Setting all values of a section for one timing contact: OUT1 CHx NOxx SCxx [(ON, OFF)] [(H, M)xx'xx] [CYxx:xx] <cr> [lf]</p>	<p>Reading out all values of a section for one timing contact: ? OUT1 CHx NOxx SCxx <cr> [lf]</p>
<p>Erasing or inserting a section in the program: PROG CHx NOxx SCxx (DEL, INS) <cr> [lf]</p> <p style="margin-left: 100px;">└─── insert section</p> <p style="margin-left: 100px;">└─── erase section</p>	
<p>Erasing or inserting a timing contact in the program OUT1 CHx NOxx SCxx [DEL, INS] <cr> [lf]</p> <p style="margin-left: 100px;">└─── insert section</p> <p style="margin-left: 100px;">└─── erase section</p>	

3 INPUT AND OUTPUT SYNTAX

changing values	reading out values
SPECIAL FUNCTIONS	
<p>Special functions (erase program/ clear memory): COD1 CLEAR <cr> [lf] clear program store (all channels) COD2 CHx NOxx <cr> [lf] erase program</p>	
	<p>Reading out configuration table: ?CONF CHx <cr> [lf]</p> <p>Reading out checksum: ?CSUM CHx NOxx <cr> [lf]</p> <p>Reading out error: ?ERR <cr> [lf]</p>
CONTROL PARAMETERS ON JUMO DICON PR	
<p>Changing control parameter: CTRL CHx name xxxxx <cr> [lf]</p>	<p>Reading out control parameter: ?CTRL CHx name xxxxx <cr> [lf]</p>

3 INPUT AND OUTPUT SYNTAX

3.3 Program run

3.3.1 Selecting and starting program

AUTO CHx NOxx [(H, M)xx'xx] <cr> [lf]

└── delay time

```
=> <SN> <cr><lf>
=> <?> <Error01> <Parameter out of Range> <cr><lf>
=> <?> <Error11> <Program running> <cr><lf>
=> <?> <Error13> <No Program> <cr><lf>
=> <?> <Error17> <Hand-Mode> <cr><lf>
=> <?> <Error18> <Interface not aktiv> <cr><lf>
=> <OK> <cr><lf>
```

Example 1:

```
PC => auto ch1 no0
DICON PR => OK
```

Program No. 0 on channel 1 is being started, the response is "OK",
i.e. the program is running!

Example 2:

```
PC => auto ch1 no4
DICON PR => ? Error 13 No Program
```

Program No. 4 on channel 1 is to be started, the response is
"? Error 13 No Program", i.e. this program does not exist
and can therefore not be started.

Example 3:

```
PC => auto ch1 no1 m00'05
DICON PR => OK
```

Program No. 1 on channel 1 is being started after a delay time of 0 min 5 sec.

3.3.2 Stopping a program

AUTO CHx OFF <cr>[lf]

```
=> <SN> <cr><lf>
=> <?> <Error01> <Parameter out of Range> <cr><lf>
=> <?> <cr><lf>
```

Example 1:

```
PC => auto ch1 off
DICON PR => OK
```

The program running on channel 1 is being stopped.

Example 2:

```
PC => auto ch2 off
DICON PR => SN
```

The program running on channel 2 is to be stopped. Since this is a 1-channel instrument this is not possible.
The response to the command is "SN" (syntax error).

3 INPUT AND OUTPUT SYNTAX

3.3.3 Reading out Hand mode

```
? HAND CHx <cr> [lf]
=> <SN> <cr><lf>
=> <?> <Error01> <Parameter out of Range> <cr><lf>
=> <?> <Error12> <No Hand-Mode> <cr><lf>
=> <?> <Error18> <Interface not aktive> <cr><lf>
=> <Wxxxxx ZSxxxxxx> <cr><lf>
```

Example 1:

```
PC => ? hand ch1
DICON PR => W+0730 ZS 10000000
The controller in channel 1 is in Hand mode. The setpoint is 730°C.
Only relay xk1 is energised.
```

Example 2:

```
PC => ? hand ch1
DICON PR => ? Error 12 No Hand-Mode
The controller is in base status or a program is running, i.e. Hand mode
is not active.
```

3.3.4 Setting setpoint and timing switches in Hand mode

```
HAND CHx ON [Wxxxxx] [ZSxxxxxx] <cr> [lf]
=> <OK> <cr><lf>
=> <SN> <cr><lf>
=> <?> <Error01> <Parameter out of Range <cr><lf>
=> <?> <Error11> <Program running> <cr><lf>
=> <?> <Error18> <Interface not aktiv> <cr><lf>
```

Example 1:

```
PC => ? hand ch1 on w+0730
DICON PR => OK
Channel 1 is set to Hand mode and a setpoint of 730°C is set.
```

Example 2:

```
PC => ? hand ch1 on w+0730
DICON PR => ? Error 11 Program running
A program is currently running, i.e. Hand mode is not possible at present.
```

3.3.5 Switching off Hand mode

```
HAND CHx OFF <cr> [lf]
=> <OK> <cr><lf>
=> <?> <Error18> <Interface not aktive> <cr><lf>
```

Example 1:

```
PC => ? hand ch 1 off
DICON PR => OK
The Hand mode of channel 1 is being switched off.
```

3 INPUT AND OUTPUT SYNTAX

3.3.6 Changing channel status

```
CHx (Hand. Auto) <cr> [lf]
=> <OK> <cr><lf>
=> <SN> <cr><lf>
=> <?> <Error01> <Parameter out of Range><cr><lf>
=> <?> <Error10> <Program not running><cr><lf>
=> <?> <Error17> <Hand-Mode> <cr><lf>
```

Example 1:

```
PC => ch1 hand
DICON PR => OK
The program changes to Hand mode = time base is held.
```

Example 2:

```
PC => ch 1 auto
DICON PR => OK
The program continues its run.
```

3.3.7 Reading out channel status

```
? CHx<cr> [lf]
=> <SN> <cr><lf>
=> <?> <Error01> <Parameter out of Range> <cr><lf>
=> <?> <Error10> <Program not running> <cr><lf>
=> <NOxx SCxx Wxxxxxx
(H, M)xx'xx (H, M)xx'xx ZSxxxxxx (Hand. Auto)<cr><lf>
```

Delay time
Residual section time

Example 1:

```
PC => ? ch1
DICON PR => NO00 SC00 W+1000 H66'00 M00'00 ZS10000000 AUTO
```

Interpretation:

```
NO00: Program No. 0
SC00: Section No. 0
W+1000: Setpoint currently 1000°C
66'00: Residual section time 66 hours 0 minutes
M00'00: If the program is not running, the delay time appears here
ZS10000000: Relay xk1 is energised
AUTO: The program is running (no Hand mode)
```

Example 2:

```
PC => ? ch1
DICON PR => NO00 SC00 W+1000 H65'54 M00'00 ZS10000000 HAND
```

The program is held up 6 minutes after the above example.

3 INPUT AND OUTPUT SYNTAX

Example 3:

PC => ? ch1
DICON PR => NO05 SC01 W+0050 M00'52 M00'00 ZS10000000 AUTO

Interpretation:

NO05: Program No. 5
SC01: Section No. 01
W+0050: Setpoint currently 50 °C
M00'52: Residual section time 52 sec
M00'00:
ZS10000000: Relays xk1 and xk8 are energised
AUTO: Program is running

3.3.8 Starting the program at any point

AUTO CHx NOxx SCxx [(H, M)xx'xx] <cr> [lf]

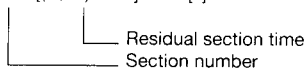

=> <SN> <cr><lf>
=> <?> <Error01> <Parameter out of Range> <cr><lf>
=> <?> <Error11> <Program running> <cr><lf>
=> <?> <Error13> <No Program> <cr><lf>
=> <?> <Error18> <Interface not aktive> <cr><lf>
=> <OK> <cr><lf>

This command can be used to start the program at any point.

Example 1:

PC => AUTO CH1 NO5 SC03
DICON PR => OK
Program No. 5 on channel 1 is being started at Section 3.

Example 2:

PC => auto ch1 no05 sc05 m00'45
DICON PR => OK
Program No. 5 on channel 1 is being started at Section 5. The residual section time is 45 sec.

3 INPUT AND OUTPUT SYNTAX

3.4 Programming

3.4.1 Setting values for one section

PROG CHx NOxx SCxx [Wxxxxx] [(H, M)xx'xx] [CYxx:xx] <cr> [lf]

```
=> <SN> <cr><lf>
=> <?> <Error01> <Parameter out of Range> <cr><lf>
=> <?> <Error14> <Last Section = SCxx> <cr><lf>
=> <?> <Error15> <Memory overflow> <cr><lf>
=> <?> <Error18> <Interface not aktive> <cr><lf>
=> <OK> <cr><lf>
```

Example 1:

```
PC => prog ch1 no0 sc0 w+0020 m00'30
DICON PR => OK
```

Program No. 0 on channel 1 is being programmed in Section 0. The setpoint is 20°C.
Time to next section: 30 sec.

Example 2:

```
PC => prog ch1 no0 sc1 w+0050 m01'00
DICON PR => OK
```

Program No. 0 on channel 1 is being programmed on section 1. The setpoint is 50°C.

NOTE:

In order to input a complete program, all sections have to be programmed individually using the above command.

3.4.2 Reading out values for one section

? PROG CHx NOxx SCxx <cr> [lf]

```
=> <SN> <cr><lf>
=> <?> <Error01> <Parameter out of Range> <cr><lf>
=> <?> <Error13> <No Program> <cr><lf>
=> <?> <Error14> <Last Section = SCxx> <cr><lf>
=> <?> <Error18> >Interface not aktive> <cr><lf>
=> <Wxxxxx (H, M)xx'xx CYxx:xx> <cr><lf>
```

Example 1:

```
PC => ? prog ch1 no0 sc0
DICON PR => W+0020 M00'30 CY00:00
```

Program No. 0 section No. 0 on channel 1 is being read out. The setpoint is 20°C.
Time up to next section: 30 sec. No cyclic repeat is programmed.

Example 2:

```
PC => ? prog ch1 no0 sc0
DICON PR => ? Error 13 No Program
```

Errors message since no program is present.

3 INPUT AND OUTPUT SYNTAX

3.4.3 Setting all values of a section for a timing contact

OUT1 CHx NOxx SCxx [(ON, OFF)] [H, M]xx'xx [CYxx:xx] <cr><lf>

```
=> <SN> <cr><lf>
=> <?> <Error01> <Parameter out of Range> <cr><lf>
=> <?> <Error14> <Last Section = SCxx> <cr><lf>
=> <?> <Error15> <Memory overflow> <cr><lf>
=> <?> <Error18> <Interface not aktive> <cr><lf>
=> <OK> <cr><lf>
```

OUT2...OUT6 see OUT1

Example 1:

```
PC => out1 ch1 no0 sc0 on m00'20
DICON PR => OK
```

Timing contact 1 in program 0 of channel 1 is being programmed. In section 0 it is energised.
Time to the next section: 20 sec.

NOTE:

In order to input a complete program, all sections have to be programmed individually using the above command.

3.4.4 Reading out all values of a section for a timing contact

? OUT1 CHx NOxx SCxx <cr> [lf]

```
=> <SN> <cr><lf>
=> <?> <Error01> <Parameter out of Range> <cr><lf>
=> <?> <Error13> <No Program> <cr><lf>
=> <?> <Error14> <Last Section = SCxx> <cr><lf>
=> <?> <Error18> <Interface not aktive> <cr><lf>
=> <(ON, OFF) (H, M)xx'xx CYxx:xx> <cr><lf>
```

OUT2...OUT6 see OUT1

Example 1:

```
PC => ? out1 ch1 no0 sc0
DICON PR => ON M00'20 CY00:00
```

The timing contact 1 section 0 of channel 1 and program No. 0 is being read out.
It is energised for a time of 20 sec. No cyclic repeat is programmed.

3 INPUT AND OUTPUT SYNTAX

3.4.5 Inserting or deleting a section in the program

PROG CHx NOxx SCxx (DEL, INS) <cr> [lf]

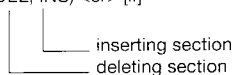

=> <SN> <cr><lf>
=> <?> <Error01> <Parameter out of Range> <cr><lf>
=> <?> <Error14> <Last Section = SCxx> <cr><lf>
=> <?> <Error15> <Memory overflow> <cr><lf>
=> <?> <Error18> <Interface not aktive> <cr><lf>
=> <OK> <cr><lf>

Example 1:

PC => prog ch1 no0 sc0 del
DICON PR => OK

Section 0 in program No. 0 on channel 1 is being deleted.

3.4.6 Inserting or deleting a section in the timing contact program

OUT1 CHx NOxx SCxx (DEL, INS) <cr><lf>

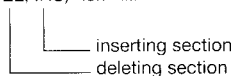

=> <SN> <cr><lf>
=> <?> <Error01> <Parameter out of Range> <cr><lf>
=> <?> <Error14> <Last Section = SCxx> <cr><lf>
=> <?> <Error15> <Memory overflow> <cr><lf>
=> <?> <Error18> <Interface not aktive> <cr><lf>
=> <OK> <cr><lf>

For OUT2...OUT6 see OUT1.

Example 1:

PC => out1 ch1 no0 sc0 del
DICON PR => OK

Section 0 in timing program No. 0 of channel 1 is being deleted.

3 INPUT AND OUTPUT SYNTAX

3.5 Special functions

3.5.1 Erasing a program

```
COD2 CHx NOxx <cr> [lf]
=> <SN> <cr><lf>
=> <?> <Error01> <Parameter out of Range> <cr><lf>
=> <?> <Error18> <Interface not aktive> <cr><lf>
=> <OK> <cr><lf>
```

Example:

```
PC => cod2 ch1 no0
DICON PR => OK
Program No. 0 on channel 1 has been erased.
```

3.5.2 Clearing the program memory

```
COD1 CLEAR <cr> [lf]
=> <SN> <cr><lf>
=> <?> <Error01> <Parameter out of range> <cr><lf>
=> <?> <Error18> <Interface not aktive> <cr> <lf>
=> <OK> <cr><lf>
```

Example:

```
PC => cod1 clear
DICON PR => OK
The entire program memory has been cleared (on all channels).
```

3.5.3 Reading out the configuration table

```
? CONF CHx <cr> [lf]
=> <SN> <cr><lf>
=> <?> <Error01> <Parameter out of Range> <cr><lf>
=> <xxxxx xxxxx x x x x x x> <cr><lf>
```

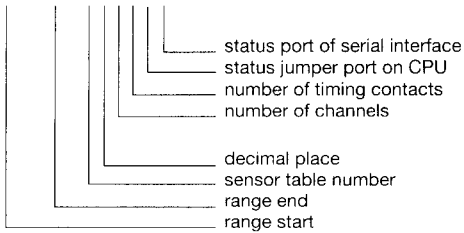

Example 1:

PC = ? conf ch1
DICON PR = +0000 +1200 03 00 01 05 FB FF

Interpretation:

+ 0000 start of range 0 °C
+ 1200 end of range 1200 °C
03 sensor table 03 = NiCr-Ni (see Operating Instructions D 95.630)
00 no decimal place
01 1-channel instrument
05 5 timing contacts available
FB jumper port CPU
FF port interface

3.5.4 Reading out checksum

? CSUM CHx NOxx <cr> [lf]
= <SN> <cr><lf> (SN = syntax error)
= <?> <Error17> <Hand-Mode> <cr><lf>
= <?> <Error18> <Interface not aktive> <cr><lf>
= <xxxx xxxx><cr><lf>

xxxx: checksum in hex. First value is analogue program, following values are timing contacts.

Example 1:

PC = ? csum ch1 no0
DICON PR = 14B2 1234 1234 1234 1234 1234
Changes in the checksum can be used to determine possible data losses
in the stored programs.

3.5.5 Reading out errors

? ERR <cr> [lf]
= <SN><cr><lf>
= <xx><cr><lf>
XX = 00: no errors
(for further details see under Section 7.2)

Example 1:

PC = ?ERR
DICON PR = 00
No error

3 INPUT AND OUTPUT SYNTAX

3.6 Additional syntax for the DICON PR

The following commands can be used to set and read out controller parameters.

Reading out: ? CTRL CHx pname <cr> [lf]
Setting: CTRL CHx pname xxxxx <cr> [lf]

The control parameters are selected with pname.

X	:	process value (read only)
XP1	:	Xp band for the heating contact
XP2	:	Xp band for the cooling contact
XSH	:	contact spacing
TV	:	rate time
TN	:	reset time
XD1	:	differential of heating contact
CY1	:	switching rate of heating contact
XD2	:	differential of cooling contact
CY2	:	switching rate of cooling contact
Y1	:	limit of maximum output signal (0 - 100%)
Y2	:	limit of maximum negative output signal
YHND	:	indication of signal Y (-100% to +100%)
RWFG	:	setting of variation range for wfg
LK1, LK2, LK3	:	programming of the lk functions (lk1 - lk8)
W1, W2, W3	:	setpoints of the limit comparators
WA	:	setpoint limit (setpoint start)
WE	:	setpoint limit (setpoint end)
XA	:	start of range
XE	:	end of range

The process value can only be read out. The output for overrange and underrange is 19999 and -19999 respectively. If the ambient temperature is overrange or underrange (in the case of thermocouples) the output is 18888.

3.6.1 Changing the controller parameters

CTRL CHx pname xxxxx <cr> [lf]
=> <OK> <cr><lf>
=> <?> <Error01> <Parameter out of Range> <cr><lf>
=> <SN> <cr><lf>

Example 1:

PC => ctrl ch1 tv +0030
DICON PR => OK

A new value of TV is being set.

Example 2:

PC => ctrl ch1 w1 +0250
DICON PR => OK

The setpoint for the limit comparator is set at 250 °C.

3 INPUT AND OUTPUT SYNTAX

3.6.2 Reading out controller parameters

```
? CTRL CHx pname <cr> [lf]
=> <SN> <cr><lf>
=> <?> <Error01> <Parameter out of Range> <cr><lf>
=> <xxxxx> <cr><lf>
```

Example 1:

```
PC => ? ctrl ch1 x
DICON PR => +0026
```

The process value of the controller on channel 1 is read out, currently 26 °C.

Example 2:

```
PC => ? ctrl ch1 tv
DICON PR => +0080
```

TV of channel 1 of the controller is being read out, currently 80 °C.

3.7 Example for syntax on RS422/485

The syntax is identical with the syntax for RS232 or TTY. The different devices are identified by placing in front the device address together with *.

Example:

```
PC => * 23 auto ch1 no5
DICON P(R) => * 23 OK
```

Program No. 5 on channel 1 of device No. 23 is being started.

3.8 Timing of transmission protocol

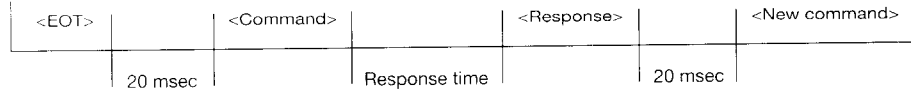

Command, response:

These are the times required for the transmission of the ASCII characters. They depend on the particular command with the parameters as well on the baud rate setting.

Response time:

The time between the receipt of the end character (CR, LF) of the command and the sending of the first character of the response. This time is independent of the baud rate settings and is

on the JUMO DICON P:

1, 2 channel	20...150 msec
3 channel	20...250 msec

on the JUMO DICON PR:

1 channel	20...500 msec
2 channel	20 - 700 msec

4 SPECIAL FEATURES OF THE INTERFACES

It should be noted that on many devices any interface inputs not in use have to be set to a defined potential. This is done by connecting them to the appropriate outputs. In the case of JUMO DICON instruments this is not required since internal pull-down or pull-up resistors ensure defined potentials on open inputs.

4.3 Bus operation with the RS422/485

A master-slave arrangement is realised which permits a superior master computer to address several slaves over a bus (e.g. 1 computer and 31 controllers/programmers). Up to 32 devices can be connected to this bus.

E.g.:

JUMO DICON Z = controller
JUMO DICON P = programmer
JUMO DICON PR = program controller

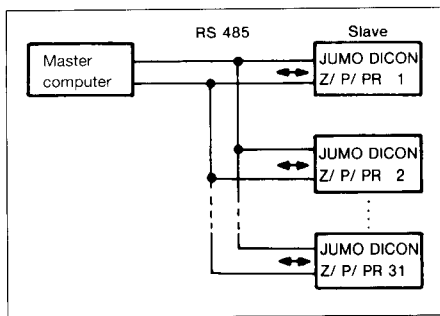
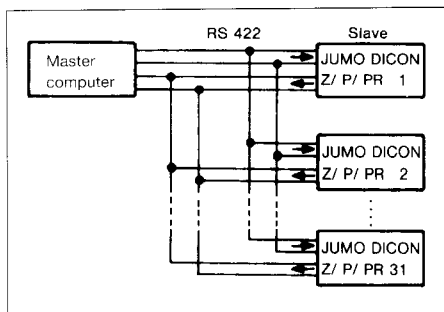

Notes on operation:

If the master computer transmits a command, this is received by each slave and stored internally in an input buffer.

After the command end character = <cr> all slaves start to decode the command. The device number transmitted with the command is compared with the device number set on the device. Only the slave with the correct number starts to process the actual command. All other devices clear their input buffer and await a fresh command.

The selected slave processes the command and transmits the response to the master computer together with its device number.

On the RS485 interface this response is again interpreted as a command for all other devices. These do however identify by the device number that the command is not valid for them, and therefore clear their input buffer again.

Since different devices can be connected to a bus, the commands may have different lengths. If a slave receives a command which is longer than its input buffer, the characters which cannot be stored in the input buffer are ignored. The command is only decoded after the command end = <cr>.

The RS485 interface must be switched over for transmitting and receiving. For this reason the timing conditions between command and response or between response and a fresh command, as specified in the transmission timing protocol, must be strictly observed. This timing condition applies also to the RS422 interface.

The output time for the response is monitored by each slave. If for any reason a response cannot be transmitted completely, the transmission is aborted after approx. 10 sec. The device changes to base status and is ready to receive a fresh command.

The handling of errors is described in Section 7.

4 SPECIAL FEATURES OF THE INTERFACES

4.4 Isolation

There is no difference between interface and external inputs with regard to isolation. The data lines and the external inputs are isolated from the outside, but not from each other. The controller section of the JUMO DICON PR is also isolated from the interface and the external inputs.

5 JUMO DICON MODE

5.1 General description

The JUMO DICON MODE is a defined interface protocol controlling the data interchange between the JUMO DICON P or JUMO DICON PR and the JUMO DICON Z.

The setpoints for the individual channels of the JUMO DICON Z are transmitted via the interface.

The setpoints can only be entered if the JUMO DICON Z is in the normal mode. No new setpoint is entered if the controller is in the programming mode. It is therefore possible for the user to break the link to the programmer and to change or hold the setpoint from the keys.

The following can be connected to the interface of a programmer/program controller:

RS422/485	31 JUMO DICON Z
RS232/V24	1 JUMO DICON Z
TTY	7 JUMO DICON Z.

For reliable data transmission it is essential to have isolated interfaces both on the programmer and on the controller.

5.2 Adjusting the JUMO DICON mode

After releasing the Philips head screw the chassis can be withdrawn from the housing.

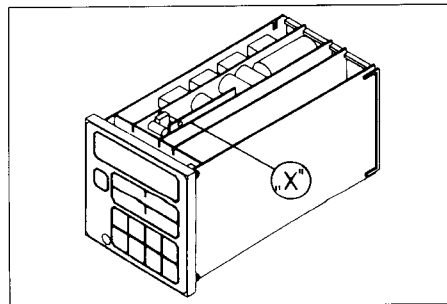
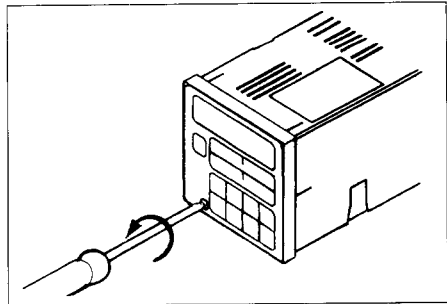

5 JUMO DICON MODE

Link Br.61 closed = JUMO DICON mode ON

The following data format is set through this link:

- No parity bit
- 1 stop bit
- 8 data bits
- 9600 baud

No device address is transmitted in the case of the RS422/485.

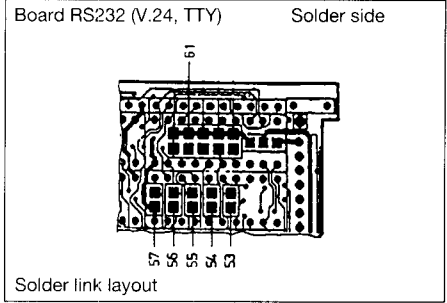
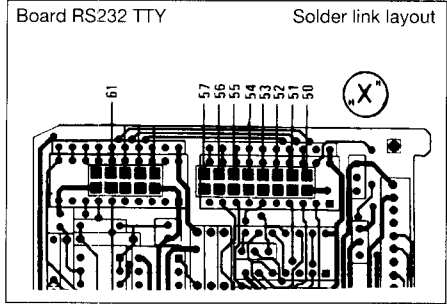

5.3 Transmission protocol

For transmission the following protocol is always used irrespective of the number of channels of the programmer/program controller:

(W)(BLANK)(W)(BLANK)(W)(BLANK)(W)(BLANK)(CR)(LF)
 W = appropriate setpoint

The transmission takes place in ASCII code, the values in HEX-integer.

Example: setpoint = 1036°C

Transmission of the hex value 040C (4-digit).

There is no response from the JUMO DICON Z.

The assignment of the setpoints to the channels of the JUMO DICON Z follows the table alongside

Channel	JUMO DICON Z			
	1	2	3	4
Programmer Controller				
JUMO DICON PR1/PG1	W1	W1	W1	W1
JUMO DICON PR2/PG2	W1	W2	W1	W2
JUMO DICON PG3	W1	W2	W3	W1

W = appropriate setpoint of the channel.

5 JUMO DICON MODE

5.4 Significance of the decimal place

The programmer/program controller transmits the setpoints independently of the decimal place.

Example 1:

The programmer (no decimal place) provides the setpoint 100°C.

The value transmitted is 100 dec.

This value is interpreted by the controller as

100 °C on the JUMO DICON Z with 0 decimal places
10.0 °C on the JUMO DICON Z with 1 decimal place
1.00 °C on the JUMO DICON Z with 2 decimal places

Example 2:

The programmer (one decimal place) provides the setpoint 200.0°C. The value transmitted is 2000 dec.

This value is interpreted by the controller as

2000 °C on the JUMO DICON Z with 0 decimal places
200.0 °C on the JUMO DICON Z with 1 decimal place
20.00 °C on the JUMO DICON Z with 2 decimal places

Example 3:

The programmer (two decimal places) provides the setpoint 30.00°C.

The value transmitted is 3000 dec.

This value is interpreted by the controller as

3000 °C on the JUMO DICON Z with 0 decimal places
300.0 °C on the JUMO DICON Z with 1 decimal place
30.00 °C on the JUMO DICON Z with 2 decimal places

It follows that the programmer/program controller and the multi-channel controller JUMO DICON Z must always have the same number of decimal places.

5.5 Timed processing of setpoint transmission in the JUMO-DICON mode

The setpoints are transmitted via the interface every 500 msec* (sampling interval). To read the setpoint(s) into the buffer the controller requires a time between a few msec and a maximum of 200 msec.

JUMO DICON P	1 + 2 channel	100 msec
JUMO DICON P	3 channel	200 msec
JUMO DICON PR	1 channel	500 msec
JUMO DICON PR	2 channel	1 sec

5.6 Error handling in the JUMO-DICON mode

If the controller identifies a format error the old setpoint is retained. If the transmitted setpoint is overrange or underange, the setpoint is taken as the start or end of range of the sensor selected on the JUMO DICON Z. There is no limitation of the setpoint within the range (we/wa) as in the case of taking a setpoint from the keys.

The setpoint(s) are only entered in the normal mode of the JUMO DICON Z. If the controller is in the programming mode no new setpoint is entered.

6 SPECIAL FEATURES OF THE JUMO DICON P

6.1 Printer operation with the JUMO DICON P

6.1.1 Protocol print-out

The programmer is capable of operating via the interface an external printer which automatically prints out a protocol of the setpoints and contact status of both channels at regular intervals.

The interface is normally set for communication operation. The programmer can be changed to printer operation by means of the solder links (Br) 58, 59 and 60.

RS232 (V. 24, TTY)

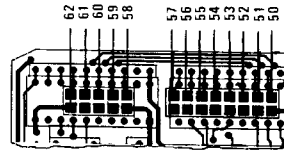

Br.60	Br.59	Br.58	Output intervals	
o	o	o	communication operation	
o	o	x	15 min	printer operation
o	x	o	30 min	
o	x	x	1 h	
x	o	o	2 h	
x	o	x	4 h	
x	x	o	8 h	
x	x	x	user specified	

RS422/485

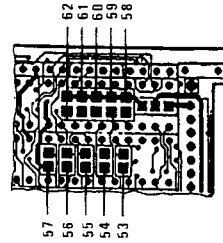

- X = closed
- o = open
- = standard setting

6 SPECIAL FEATURES OF THE JUMO DICON P

6.1.2 Printing out the programs

Using printer operation it is possible to list stored programs for protocolling via a printer. This mode is selected through the special functions

Cd-09 print programs selectively

Cd-10 print out all programs

(see Operating Instructions D 95.620)

The print-out of a program takes place according to the following format:

CH1	Prog00	SC00	W+0000	M00'20	
		SC01	W+2000	M00'10	
		SC02	W+0100	H01'00	CY00:02
		SC03	W+1000	H01'00	
		SC04	W+2000	H10'00	
		SC05	W+0100	M00'00	
	Out-1	SC00	OFF	M00'01	
		SC01	ON	M00'01	CY00:CC
	Out-2	SC00	ON	M02'00	
		SC01	OFF	H01'00	
		SC02	ON	H01'00	CY00:CC
	Out-3	SC00	ON	M00'01	
		SC01	OFF	M00'01	CY00:CC
	Out-4	-----			
	Out-5	SC00	ON	M00'01	
		SC01	OFF	M00'01	CY00:CC
	Out-6	-----			

6.1.3 Handshake and device addresses

Printer operation may involve transmitting longer data blocks while the printer used may have a lower processing speed. It may therefore be necessary to use the handshake lines (see section handshake with RS232).

No handshake lines are available on the RS422/485 and a sufficiently low baud rate must therefore be set instead.

A special feature of the RS422/485 is that no device address is output during printer operation, i.e. in this special case only one programmer can be linked to one printer.

6 SPECIAL FEATURES OF THE JUMO DICON P

6.2 Copying of programs

Programs can be copied between two programmers. It is essential to ensure that both instruments have the same interface parameter settings. In addition the two instruments must have the same configuration (identical range, decimal places, sensor table).

In this mode there are different addresses between the two devices in the RS422/485 so that copying is not possible.

The selection of the mode takes place through the special functions

Cd-07 Selective copying of programs

Cd-08 Copying all programs of one channel.

(see Operating Instructions D 95.620)

7 ERROR HANDLING

7.1. Error handling and error report

Forbidden values within the syntax are recognised and result in an error message. The error message is arranged as follows:

<?> <Error01> <text in full> <cr> <lf>

The error number serves for rapid error coding by an external PC.

<SN>	<cr><lf>	(SN = syntax error)
<?>	<Error01>	<Parameter out of Range> <cr><lf>
<?>	<Error10>	<Programm not running> <cr><lf>
<?>	<Error11>	<Program running> <cr><lf>
<?>	<Error12>	<No Hand-Mode> <cr><lf>
<?>	<Error13>	<No Program> <cr><lf>
<?>	<Error14>	<Last Section = SCxx> <cr><lf>
<?>	<Error15>	<Memory overflow> <cr><lf>
<?>	<Error16>	<Checksum Error> <cr><lf>
<?>	<Error17>	<Hand-Mode> <cr><lf>
<?>	<Error18>	<Interface not aktiv> <cr><lf>

This means no values can currently be read out through the interface, e.g. when the instrument is being programmed manually.

<?> <Error19> <PGM-Pointer Error> <cr><lf>

If error messages appear despite correct syntax this may have the following causes, among others:

- disturbances in the interface line
- faults in the JUMO DICON P/PR. The software recognises faulty transmission and re-initialises the instrument.

It follows that errors are not likely to recur if the command is repeated.

Under unfavourable conditions the JUMO DICON P/PR does not transmit a response (not even an error message) to the PC.

The error handling of the user software should therefore take account of the following:

- if there is an error message despite correct syntax and parameters, or if there is no response from the JUMO DICON P/PR the command should be repeated.
- if several repeats are always followed by the same error message or if there is no response, there must be an appropriate error handling procedure.

7 ERROR HANDLING

7.2 Error read-out

Any errors during operation are recognised by the instrument and shown on the display by a message 'Err-.' These errors can also be read out via the interface using the following syntax:

```
? ERR    <cr>[[f]
=> <SN>  <cr><lf>
=> <xx>  <cr><lf>
```

xx = 00: no error

The following responses are possible:

- Err-1: checksum error in the analogue program (RAM fault)
- Err-2: checksum error in the timing contact program (RAM fault)
- Err-3: fast forward error. An infinite repeat is programmed before the section to be started.
- Err-4: battery voltage too low
- Err-5: watchdog error, hardware watchdog faulty
- Err-6: error in restart data after supply failure or reset, checksum error of the program status data (100 msec)
- Err-7: checksum error of the configuration table in the RAM
- Err-8: program pointer error.

Additionally in the case of the JUMO DICON P

- Err-9: checksum error in the table for the analogue output values during base status.

Additionally in the case of the JUMO DICON PR

- Err-9: faulty calibration constant of the process value
- Err10: process value larger or smaller than indication capacity
- Err11: error in user-specific recalibration. X0 X1 are already occupied by 0, i.e. user-specific recalibration not activated
- Err12: humidity controller selected on the input card but the instrument is not set for humidity (e.g. not 2 channels, no resistance input ...)

The remedies for these error messages are described in the Operating Instructions D 95.620 or D 95.630.

7 ERROR HANDLING

7.3 Special features in the error handling in the case of RS 422/485

After transmitting a command the master computer must await the response of the slave. This time must be monitored with a time-out counter. A fresh command can only be transmitted when the response has been received or at the end of time-out. The size of the time-out counter depends on the receiving instrument and the baud rate setting.

- (a) Error in the transmitted device number:
 - the response comes not from the intended device but from another device. This is identified by the master computer from the response (device number is transmitted in the response)
 - no device responds since the number is not in use; after time-out the command is repeated by the master computer
- (b) Error in the command part for the device:
 - the device responds with an error message
- (c) No command end = <cr> is recognised:
 - no device responds. After the time-out at the master computer the command is repeated.

After an error the master computer should transmit an EOT in order to set the slaves to base status, see Section 4.1.

7.4 Check list - error treatment and remedies

No function at all	Remedy (see Section)
Are all devices fitted with the same interface card?	
Have the same parameters been set? (data format, baud rate)	2
Has the device address for RS422/485 been set correctly?	2.3
Have the handshake lines been connected up correctly?	4.2; 6.1.3; 9
Partial function	
Have all wiring recommendations been observed?	8
Have the termination resistances been connected up?	8
Is the instrument in the wrong operating mode? (e.g. manual programming!)	

8 WIRING RECOMMENDATIONS

Special care should be taken with the electrical connections of the instruments. Optimised wiring in conjunction with internal measures such as watchdog circuit and special software routines, ensures maximum operating and transmission security.

Special attention should be paid to the following points:

Connecting wiring:

Screened cable should be used where possible for connecting up the interfaces. The screen must be connected to protective ground at one end.

On the RS422/485 the cable should additionally be twisted. It is advisable to connect up also the signal ground (GND connection 29) of the instruments to ensure defined potentials.

Termination resistances¹⁾:

Termination resistances are normally not necessary on the JUMO DICON PR/P. The interfaces are already fitted internally with 6.8 k Ω pull-up or pull-down resistors. Any termination resistors which are connected up must not lower the total resistance below 210 Ω , i.e. no resistors at all for 32 devices connected together.

General installation notes:

- Ensure star-shaped wiring layout including ground connection.
- Supply voltage fluctuations are permitted only within the specified tolerances.
- All sensor and signal lines should as far as possible be run physically separated from control and supply lines.
- Where several electronic devices are installed, a separate supply line to each (including ground) is advantageous.
- Screened signal lines should only be grounded at the programmer/program controller.
- Electronic instruments should where possible be physically separated from contactor circuits.
- Where inductive loads such as contactors, solenoid valves etc. are mounted close to the instrument it is advisable to prevent interference by fitting the contactor coil with an RC-module.
- No control circuit (relay, contactor) should be connected to the supply terminals of the instruments.

¹⁾ Because of the high input impedances of the interfaces the bus line formally represents a wave guide open at both ends, i.e. a reflection with a 180° phase change takes place at both ends. With high transmission rates there may be destructive interference between the forward and the reverse wave, resulting in faults. It is for this reason that parallel damping resistors are inserted into the bus (between A and B) in the case of interfaces at the ends of the bus.

9 WIRING DIAGRAMS

9.1 Connection PC - RS232

Connection with an IBM XT, AT or compatible computer

Pin connections at the 9-pin sub-D socket

Programmer	Terminal	Pin	PC
RxD	23	2	RxD
TxD	25	3	TxD
CTS	24	8	CTS
RTS	26	7	RTS
GND	29	5	GND
		1	DCD
		4	DTR
		6	DSR

Pin connections at the 25-pin sub-D socket

Programmer	Terminal	Pin	PC
RxD	23	3	RxD
TxD	25	2	TxD
CTS	24	5	CTS
RTS	26	4	RTS
GND	29	7	GND
		8	DCD
		20	DTR
		6	DSR

9 WIRING DIAGRAMS

9.2 Connection PC - RS422

Connection with an IBM XT, AT or compatible computer

Pin connections at the 9-pin sub-D socket
(Version Digi Board)

Programmer	Terminal	Pin	Digi Board version
(OUT) (TxD)	A(+)	25 ——— 6	A(+)
	B(-)	26 ——— 7	B(-)
	GND	29	(IN) (RxD)
(IN) (RxD)	A(+)	23 ——— 8	A(+)
	B(-)	24 ——— 9	B(-)

Pin connections at the 9-pin sub-D socket
(according to PTB 50.20)

Programmer	Terminal	Pin	acc. to PTB 50.20
(OUT) (TxD)	A(+)	25 ——— 4	A(+)
	B(-)	26 ——— 9	B(-)
	GND	29 - - - - 2+7	GND
(IN) (RxD)	A(+)	23 ——— 3	A(+)
	B(-)	24 ——— 8	B(-)

Pin connections at the 15-pin sub-D socket
(according to PTB 50.20)

Programmer	Terminal	Pin	acc. to PTB 50.20
(OUT) (TxD)	A(+)	25 ——— 4	A(+)
	B(-)	26 ——— 11	B(-)
	GND	29 - - - - 7	GND
(IN) (RxD)	A(+)	23 ——— 2	A(+)
	B(-)	24 ——— 9	B(-)

Note:

The connections to the sub-D socket may differ depending on the manufacturer. They have to be taken from the appropriate handbook!

Connection of the signal grounds (GND) is not essential. It is however useful if insufficient isolation causes greatly differing potentials to be produced at the instruments.

9 WIRING DIAGRAMS

9.3 Connection PC – RS485

Connection with an IBM XT, AT or compatible computer

Pin connections at the 9-pin sub-D socket
(according to PTB 50.20)

Programmer	Terminal	Pin	acc. to PTB 50.20	
(OUT) (TxD)	A(+)	25	4	A(+) B(-)
	B(-)	26	9	
	GND	29	2+7	GND
(IN) (RxD)	A(+)	23	3	A(+)
	B(-)	24	8	B(-)

Pin connections at the 15-pin sub-D socket
(according to PTB 50.20)

Programmer	Terminal	Pin	acc. to PTB 50.20	
(OUT) (TxD)	A(+)	25	4	A(+) B(-)
	B(-)	26	11	
	GND	29	7	GND
(IN) (RxD)	A(+)	23	2	A(+)
	B(-)	24	9	B(-)

Note:

The connections to the sub-D socket may differ depending on the manufacturer. They have to be taken from the appropriate handbook!

Connection of the signal grounds (GND) is not essential. It is however useful if insufficient isolation causes greatly differing potentials to be produced at the instruments.

9 WIRING DIAGRAMS

9.4 Connection JUMO DICON P/PR - JUMO DICON Z in JUMO-DICON Mode

RS232 interface

Programmer	Terminal	Terminal	JUMO DICON Z
RxD	23	23	RxD
TxD	25	25	TxD
GND	29	29	GND

RS422 interface

Programmer	Terminal	Terminal	JUMO DICON Z
(OUT) A(+)	25	23	A+ (IN)
(TxD) B(-)	26	24	B- (RxD)
GND	29	29	GND

RS485 interface

Programmer	Terminal	Terminal	JUMO DICON Z
A(+)	25	25	A(+)
B(-)	26	26	B(-)
GND	29	29	GND

TTY interface

Programmer	Terminal	Terminal	JUMO DICON Z
	26	23	
	29	24	

10 APPENDIX

10.1 ASCII Table

Bits	7 6 5				0	0	0	0	1	1	1	1	
	4	3	2	1	Column	0	1	2	3	4	5	6	7
				Row									
	0	0	0	0	0	NUL	DLE	SP	0	@	P		p
	0	0	0	1	1	SOH	DC1	!	1	A	Q	a	q
	0	0	1	0	2	STX	DC2	"	2	B	R	b	r
	0	0	1	1	3	ETX	DC3	#	3	C	S	c	s
	0	1	0	0	4	EOT	DC4	\$	4	D	T	d	t
	0	1	0	1	5	ENQ	NAK	%	5	E	U	e	u
	0	1	1	0	6	ACK	SYN	&	6	F	V	f	v
	0	1	1	1	7	BEL	ETB	'	7	G	W	g	w
	1	0	0	0	8	BS	CAN	(8	H	X	h	x
	1	0	0	1	9	SKIP HIT	EM)	9	I	Y	i	y
	1	0	1	0	10(a)	LF	SUB	*	:	J	Z	j	z
	1	0	1	1	11(b)	VT	ESC	+	;	K	[k	{
	1	1	0	0	12(c)	FF	FS	,	<	L	\	l	
	1	1	0	1	13(d)	CR	GS	-	=	M]	m	}
	1	1	1	0	14(e)	SO	HOME RS	.	>	N	^	n	-
	1	1	1	1	15(f)	SI	NEW LINE US	/	?	o	-	o	DEL RUB

ASCII Code Table



Abbreviations For Control Characters

NUL	null	SO	shift out	FS	file separator
SOH	start of heading	SI	shift in	GS	group separator
STX	start of text	DLE	data link escape	RS	record separator
ETX	end of text	DC1	device control 1	US	unit separator
EOT	end of transmission	DC2	device control 2	SP	space
ENQ	enquiry	DC3	device control 3	DEL	delete
ACK	acknowledge	DC4	device control 4		
BEL	bell	NAK	negative acknowledge		
BS	backspace	SYN	synchronous idle		
HT	horizontal tabulation	ETB	end of transmission block		
LF	linefeed	CAN	cancel		
VT	vertical tabulation	EM	end of medium		
FF	form feed	SUB	substitute		
CR	carriage return	ESC	escape		

10 APPENDIX

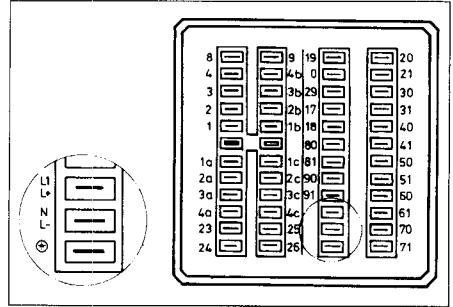
10.2 Connections at the interface on the JUMO DICON P/PR



Connection	Terminals			
Serial interface V.24 (RS232C)	RxD	23	IN	Received data (receiving line)
	TxD	25	OUT	Transmitted data (transmitting line)
	CTS	24	IN	Clear to send (ready to transmit)
	RTS	26	OUT	Request to send (transmitting circuit)
	GND	29		Signal ground
Serial interface RS422	A + B -	25 + 24 -	IN	Received data (receiving pair)
	A + B -	25 + 26 -	OUT	Transmitted data (transmitting pair)
	GND	29		Signal ground
Serial interface RS485	A + B -	25 + 26 -	OUT/IN	Transmitted/received data (transmitting/receiving pair)
	GND	29		Signal ground
Serial interface TTY	RxD+ RxD-	23 + 24 -	IN	Received data (receiving pair) 
	TxD+ TxD-	25 + 26 -	OUT	Transmitted data (transmitting pair) 
	GND	29		Signal ground

10 APPENDIX

10.3 Pin connections

10.3.1 RS232 interface*

DB-25 pin	Signal direction	Code			Techn. abbrev.	Description	
		DIN	V.24	RS232		German	English
1		E1	101	AA	GND	Schutzerde	Protective Ground; earth ground
2	←	D1	103	BA	XMIT	Sendedaten	Transmitted data
3	→	D2	104	BB	RCVR	Empfangsdaten	Received data
4	←	S2	105	CA	RTS	Sendeteil einschalten	Request to send
5	→	M2	106	CB	CTS	Sendebereitschaft	Ready for sending; clear to send
6	→	M1	107	CC	DSR	Betriebsbereitschaft	Data set ready
7		E2	102	AB	GND	Betriebserde	Signal ground; common return; logic ground
8	→	M5	109	CF	DCD	Empfangssignalpegel	Data channel received line signal detector data carrier detector
11	←	S5	126	-		Hohe Sendefrequenz- lage einschalten	Select transmit frequency
12	→	HM5	122	-	SCF	Hilfskanal-Empfangs- signalpegel	Backward channel received line signal detector; supervisory (secondary) channel carrier detector
13	→	HM2	121	-		Hilfskanal-Sende- bereitschaft	Backward channel ready; supervisory (secondary) channel ready
14	→	HD1	118	-		Hilfskanal-Sendedaten	Transmitted backward channel data; transmitted supervisory (secondary) channel data
15		T2	114	DB	-	Sendeschrittakt von der DÜ-E	Transmitted signal element timing; transmitted clock internal
16		HD2	119	-		Hilfskanal-Empfangs daten	Received backward channel data; received supervisory (secondary) channel data

* from CHIP 12/1982

10 APPENDIX

DB-25 pin	Signal direction	Code DIN	V.24		Techn. abbrev.	Description	
			RS232			German	English
17	→	T4	115	DD	-	Empfangsschrittakt	Receiver signal element timing; received bit clock
19	←	HS2	120	-	-	Hilfskanal-Sendeteil einschalten	Transmit backward channel data; transmit supervisory (secondary) channel data
20	←	S1.1.	108/1	-	-	Übertragungsleitung einschalten	Connect data set on line
	←	or S1.2	108/2	CD	DTR	Datenendeinrichtung betriebsbereit	Data terminal ready
22	→	M3	125	CE	-	Ankommender Ruf	Calling indicator; ring indicator
23	←	S4	111	CH	-	Hohe Übertragungsgeschwindigkeit einschalten	Data signal rate selector
24	←	T1	113	DA	-	Sendschrittakt zur DÜ-E	Transmitter signal element timing; transmitted bit clock, external

* from CHIP 12/1982

10 APPENDIX

View from solder side

Pin connections for data terminal to DIN 66 258/3, 25-pin subminiature-D plug (socket). Only the most important connections are shown. The pin connections also apply to computers such as IBM XT, AT, PC.

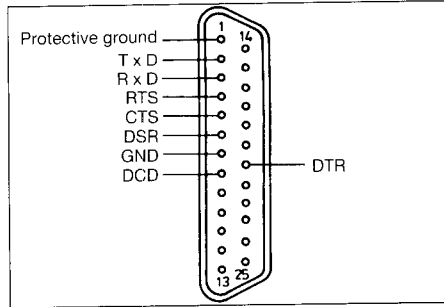

Pin connections at the 9-pin sub-D socket on JUMO instruments

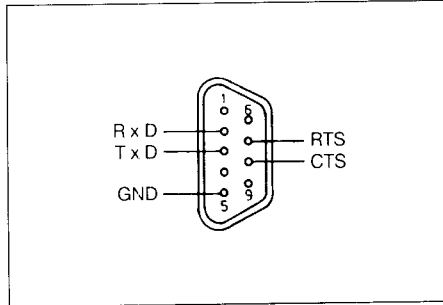

Connections at the 9-pin subminiature-D socket of IBM, e.g. IBM XT, AT, PC (RI = ring indicator)

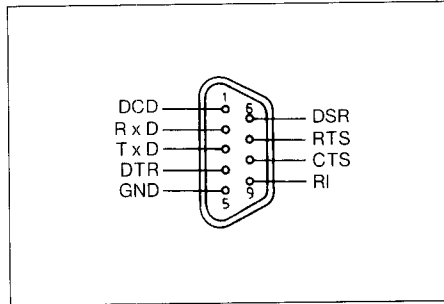

10 APPENDIX

10.3.2 RS422/485 interface according to PTB 50.20

9-pin

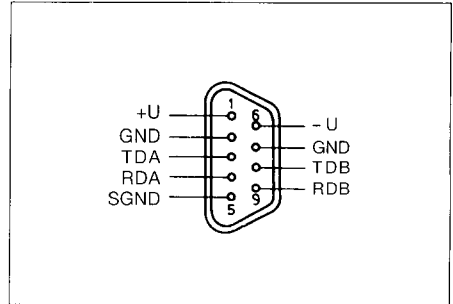

15-pin

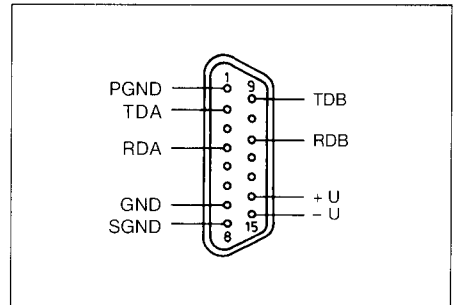

Explanation of the signal names and line functions for the pin connections of the 9-pin and 15-pin connectors.

Code		Line function
in PTB 50.20	50.10	
TDA (transmit data A) RDA (receive data A) TDB (transmit data B) RDB (receive data B) SGND (signal ground) PGND (protective ground)	T(A) R(A) T(B) R(B) G	transmission data, terminal A receiving data, terminal A transmission data, terminal B receiving data, terminal B operation ground screen
GND (ground) + U - U		operating ground and voltages to supply external peripherals
CLK A (clock A) CLK B (clock B)		strobe A strobe B

10 APPENDIX

Pin connections of RS422/485 interface (acc. to Digi Board)

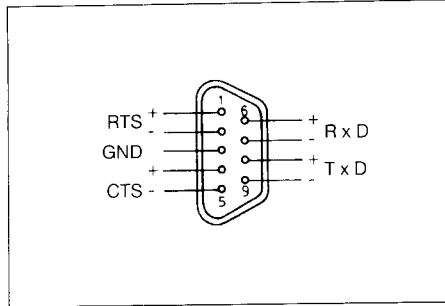

Note:
The connections to the sub-D socket may differ depending on the manufacturer. They have to be taken from the appropriate handbook!

10.4 Overview of permitted levels and line lengths

Table 1	Signal status		Max line length	No. of lines	Devices per interface	Application	Notes
	log.0	log.1					
TTY	0 mA	20 mA	1000 m	2	1 ¹⁾	teleprinter monitors printers	widely used
V.24 (RS232)	+3.. +15V	-3.. -15V	30 m	2 data 2 handshake 1 ground (extra)	1	computers, instruments	
RS422	0 V 5 V	5 V 0 V	1200 m	2 receive 2 transmit 1 ground	32		unaffected by interference, bussable
RS485	0 V 5 V	5 V 0 V	1500 m	2 data 1 ground	32		
IEC (IEEE)	5 V	0 V	2 - 20m ²⁾	8 data 3 handshake 5 control	16	laboratory instruments	very fast, liable to interference
Centronics	0 V	5 V	3 m	8 data 3 handshake extra	1	printer	

¹⁾ ring structures with several devices are possible
max. distance between two devices 2 m