

## Thyristor Power Units

# B 70.9040.0 Operating Instructions



<b>1</b>	<b>Introduction</b>	<b>7</b>
1.1	Preface	7
1.2	Typographical conventions	8
1.2.1	Warnings	8
1.2.2	Note signs	8
1.3	Description	9
1.4	Type designation	9
1.4.1	Type extensions (extra codes)	10
1.4.2	Standard accessories	10
1.4.3	Accessories	11
1.5	Block diagram	11
1.6	Front panel indicators and adjustments	12
<b>2</b>	<b>Operating modes</b>	<b>13</b>
2.1	Phase-angle control with soft start and current limiting	13
2.2	Burst-firing operation, for resistive loads	14
2.3	Burst-firing operation for transformer loads and loads with a high positive temperature coefficient TC (mixed operation)	15
<b>3</b>	<b>Installation</b>	<b>17</b>
3.1	Important installation notes	17
3.2	Filtering and interference suppression	18
3.3	Installation site and climatic conditions	18
3.4	Wall mounting	19
3.4.1	TYA-110/3, 025..100	19
3.4.2	TYA-110/3,150 and TYA-110/3, 250	20
3.5	DIN rail mounting	21
3.5.1	TYA-110/3, 025 ..100	21
<b>4</b>	<b>Electrical connection</b>	<b>23</b>
4.1	Connection diagram	23
4.1.1	Type TYA-110/3, 025, - 050, - 075, - 100, ...	25
4.1.2	Type TYA-110/3, 150, ...	25
4.1.3	Type TYA-110/3, 250, ...	25
4.2	Single-phase operation: line/phase – N	26
4.3	Single-phase operation: phase – phase	27
4.4	Star configuration: with star point connected to N	28
4.5	Open delta configuration (six-wire circuit)	29

# Contents

---

<b>4.6</b>	<b>Free-running economy circuit, purely resistive loads</b> .....	<b>30</b>
<b>4.7</b>	<b>Master-slave economy circuit, with resistive/inductive loads</b> .....	<b>31</b>
<b>5</b>	<b>Commissioning</b> .....	<b>33</b>
<b>5.1</b>	<b>Adjust control input (full wave)</b> .....	<b>33</b>
5.1.1	Setting the maximum power output .....	33
5.1.2	Input signal attenuator .....	33
<b>5.2</b>	<b>Setting the base load</b> .....	<b>34</b>
<b>5.3</b>	<b>Setting the current limit</b> .....	<b>35</b>
5.3.1	Alteration of the current limit $I_{max}$ , as a function of the voltage on Terminal 9 .....	36
<b>5.4</b>	<b>Setting the phase angle for the first half-wave</b> .....	<b>36</b>
<b>5.5</b>	<b>Load and part-load failure monitoring</b> .....	<b>37</b>
5.5.1	Setting the threshold for load failure indication .....	37
5.5.2	Setting for master-slave and free-running economy circuit .....	38
<b>5.6</b>	<b>External changeover of operating modes</b> .....	<b>38</b>
<b>5.7</b>	<b>Blown fuse indication</b> .....	<b>38</b>
<b>6</b>	<b>Settings</b> .....	<b>39</b>
<b>6.1</b>	<b>Opening the housing</b> .....	<b>39</b>
<b>6.2</b>	<b>Adjustment switches S1 – 21 and pin headers X503 / X504</b> .....	<b>40</b>
<b>6.3</b>	<b>Summary of possible settings</b> .....	<b>42</b>
<b>6.4</b>	<b>Control inputs</b> .....	<b>43</b>
6.4.1	Combinations of external potentiometer and electronic controller .....	44
<b>6.5</b>	<b>Subsidiary control loops</b> .....	<b>45</b>
<b>6.6</b>	<b>Actual (power) output</b> .....	<b>46</b>
<b>6.7</b>	<b>Load current adaptation (only with extra code TR/T0)</b> .....	<b>47</b>
<b>6.8</b>	<b>Select operating modes and load types</b> .....	<b>47</b>
<b>6.9</b>	<b>Economy circuit</b> .....	<b>48</b>
6.9.1	Free-running economy circuit (asynchronous switching) for resistive loads .....	49
6.9.2	Master-slave economy circuit (synchronous switching) for resistive and transformer loads .....	49
<b>6.10</b>	<b>Firing-pulse inhibit</b> .....	<b>50</b>
<b>7</b>	<b>Technical data</b> .....	<b>51</b>
<b>7.1</b>	<b>Load circuit</b> .....	<b>51</b>
<b>7.2</b>	<b>Control</b> .....	<b>51</b>
<b>7.3</b>	<b>General data</b> .....	<b>51</b>

<b>8</b>	<b>Faults .....</b>	<b>53</b>
<b>8.1</b>	<b>Fault-finding .....</b>	<b>53</b>
<b>8.2</b>	<b>Replacing the semiconductor fuse .....</b>	<b>53</b>
8.2.1	Type TYA-110/3, 025 to 100, ... ..	53
8.2.2	Type TYA-110/3, 150, ... ..	54
8.2.3	Type TYA-110/3, 250, ... ..	54

# Contents

---

## 1.1 Preface



Please read these operating instructions before starting up the instrument. Keep them in a place that is accessible to all users at all times.

Please help us to improve this manual.

Your suggestions will be welcome.

Fax: in Germany (0661) 6003-862  
abroad +49 661 6003-607



If any difficulties arise during commissioning, you are asked not to carry out any unauthorized manipulation. You could endanger your rights under the instrument warranty!

Please contact the nearest subsidiary or the main factory in such a case.



When returning chassis, modules or components, the regulations of EN 100 015 "Protection of electrostatically sensitive components" must be observed. Use only the appropriate **ESD** packaging for transport.

Please note that we cannot accept any responsibility for damage caused by ESD (electrostatic discharge).

# 1 Introduction

---

## 1.2 Typographical conventions

### 1.2.1 Warnings

The signs for **Danger** and **Caution** are used in this manual under the following conditions:



#### **Danger**

This symbol is used where there may be **danger to personnel** if the instructions are disregarded or not followed accurately!



#### **Caution**

This symbol is used where there may be **damage to equipment or data** if the instructions are disregarded or not followed accurately!



#### **Caution**

This symbol is used if precautions must be taken when handling **electrostatically sensitive components**.

### 1.2.2 Note signs



#### **Note**

This symbol is used to draw your **special attention** to a remark.



#### **Reference**

This symbol refers to **additional information** in other manuals, chapters or sections.

abc<sup>1</sup>

#### **Footnote**

Footnotes are comments that **refer to specific parts** of the text. Footnotes consist of two parts:

- 1) The marking in the text, arranged as continuous superscript numbers.
- 2) The footnote text at the bottom of the page, in a smaller typeface than the main text, and preceded by a number and a stop.

\*

#### **Handling instructions**

This symbol marks the description of a **required action**.

The individual steps are indicated by asterisks, for example:

- \* Disconnect the instrument completely from the supply
- \* Remove the instrument cover

## 1.3 Description

<b>Application</b>	A thyristor power unit can be used wherever sizeable resistive or inductive loads are switched frequently – for instance, in industrial furnaces and plastics processing.
<b>Operating modes</b>	The thyristor power units can operate under phase-angle control with adjustable current limiting or in burst-firing mode, depending on the setting of the internal switch. An external switch may also be used to change over the operating mode. In burst-firing mode, the phase angle can be cut back for the first half-cycle, for driving transformer loads.
<b>Regulation</b>	Variations in the line supply voltage have no effect on the control-loop regulation during operation. This is ensured by a subsidiary $V^2$ , P or $I^2$ control loop. An input signal attenuator (trimmer) permits the restriction of the control range, and a base load can be set by an external potentiometer. In burst-firing mode an economy circuit can be used for multi-phase loads. With phase-angle control, the target phase angle that is set by the controller is gradually approached from the initial $180^\circ$ , thus avoiding high surge currents (soft start).
<b>Versions</b>	The power stage is composed of 2 thyristors connected in anti-parallel, the insulated heatsink, and the control electronics. Thyristor units for up to 50A rated load can either be snapped onto a 35mm DIN rail, or mounted on a baseplate fixed to a wall. Units for 75A or higher rated load can only be wall-mounted.
<b>Standards</b>	The thyristor power units meet VDE 0160 5.5.1.3 (5/88) and VDE 0106 Part 100 (3/83). Earthing must be carried out in accordance with the regulations of the local electrical supply utility.

## 1.4 Type designation

The basic version, TYA-110/3, includes the following features:

- Voltage, current and potentiometer input
- Input signal is freely selectable
- Operating mode is freely selectable
- Phase-angle reduction of 1st half-wave for burst-firing operation
- Supply line voltage monitoring
- Input signal attenuation by trimmer
- Soft start in phase-angle operation
- $V^2$ -control with adjustable power level output signal
- Master-slave economy circuit
- Firing-pulse inhibit

# 1 Introduction

---

TYA-110/3	,	<span style="border: 1px solid black; padding: 2px;">...</span>	,	<span style="border: 1px solid black; padding: 2px;">...</span>	,	<span style="border: 1px solid black; padding: 2px;">..</span>	Thyristor power unit for analog control
		025					Load current 25A
		050					Load current 50A
		075					Load current 75A
		100					Load current 100A
		150					Load current 150A
		250					Load current 250A
				024			Rated load voltage 24V <sup>1</sup>
				042			Rated load voltage 42V <sup>1</sup>
				115			Rated load voltage 115V <sup>1</sup>
				230			Rated load voltage 230V <sup>1</sup>
				265			Rated load voltage 265V <sup>1</sup>
				400			Rated load voltage 400V <sup>1</sup>
				460			Rated load voltage 460V <sup>1</sup>
				500			Rated load voltage 500V <sup>1</sup>
						TR	Indication of part-load failure or blown fuse through built-in relay and LED.
						TO	Indication of part-load failure or blown fuse through optocoupler
						MS	Master-slave circuit 2 pre-assembled power units on a mounting plate, ready for connection

1. Rated load voltage = supply voltage for the control electronics

## 1.4.1 Type extensions (extra codes)

**TR** Extended version, with indication of part-load failure (adjustable by trimmer) or blown fuse through common relay contact and LED.

This version also includes:

- Current limiting (internal, external) and rated current adjustment at  $I \leq I_N/2$
- Free selection of the subsidiary control-loop type ( $V^2$ ,  $I^2$  or P).  
A free-running economy circuit can be implemented with P-control!
- Power level output signal can be switched to:  $V^2$ , P,  $I^2$

**TO** as for TR, but with signaling via optocoupler

**MS** Master-slave circuit: 2 pre-assembled power units on a mounting plate, ready for connection.

## 1.4.2 Standard accessories

- 1 Mounting plate for wall-mounting
- 1 Operating Instructions

## 1.4.3 Accessories

Super-fast semiconductor fuses to protect the thyristors from short-circuits (no supply line fusing).

32A for $I_N = 25A$ ,	Sales No. 70/00068009
80A for $I_N = 50A$ ,	Sales No. 70/00068011
125A for $I_N = 75A$ ,	Sales No. 70/00081800
160A for $I_N = 100A$ ,	Sales No. 70/00081801
350A for $I_N = 150A$ ,	Sales No. 70/00083318
550 A for $I_N = 250A$ ,	Sales No. 70/00371964

Assembly kit for DIN rail mounting, for 25A and 50A versions,  
Sales No. 70/00067312

## 1.5 Block diagram

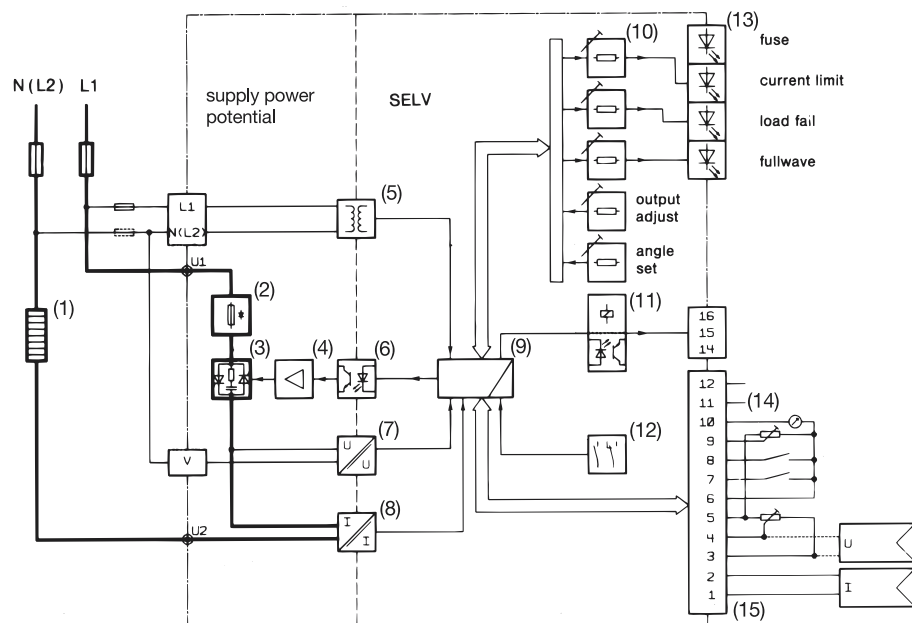

- |   |  |
|---|--|
| (1) Load  | (9) Control electronics  |
| (2) Super-fast semiconductor fuse               | (10) Trimmer on front panel  |
| (3) Thyristor module with RC protection network | (11) Error signal output via relay or optocoupler                      |
| (4) Driver stage for thyristor module           | (12) Configuration switch  |
| (5) Power supply for control electronics        | (13) Signal LEDs   |
| (6) Optocoupler                                 | (14) Master-slave connections  |
| (7) Voltage converter                           | (15) Output level setting, operating inputs, power level output signal |
| (8) Current transformer                         |  |

# 1 Introduction

---

## 1.6 Front panel indicators and adjustments

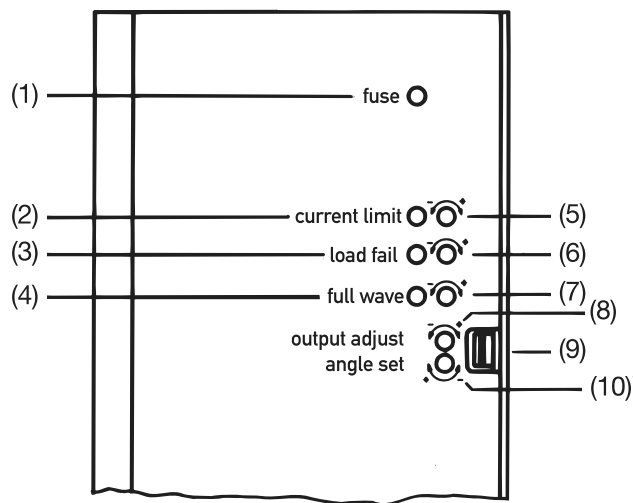

- |  |  |
|--|--|
| <b>(1)</b> Indicator LED for blown semiconductor fuse                                      | <b>(6)</b> Adjustment of threshold for part-load failure indication (with extra code TR or TO) |
| <b>(2)</b> LED for current indication  | <b>(7)</b> Adjustment of full output   |
| <b>(3)</b> LED for load-failure indication   | <b>(8)</b> Adjustment of power level signal  |
| <b>(4)</b> LED for full-output indication  | <b>(9)</b> Spring clip to release cover  |
| <b>(5)</b> Adjustment of current limit in phase-angle operation (with extra code TR or TO) | <b>(10)</b> Adjustment of phase-angle reduction for 1st half-wave in burst-firing operation    |

### 2.1 Phase-angle control with soft start and current limiting

In this mode of operation, the power is regulated by altering the phase angle. This method is suitable for transformer and resistive loads. During the switch-on period the phase-angle is gradually advanced by the controller to provide a soft start. This prevents high surge currents at switch-on.

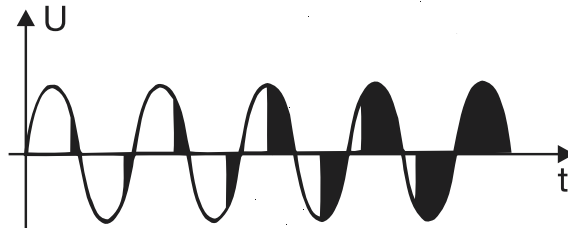

#### Current limiting

For loads with an initial (cold) resistance that is significantly lower than the resistance after warming up, such as Kanthal-Super heater elements, it is advisable to make use of current limiting (only with extra code TR or TO). While current limiting is in operation, the phase angle during soft start remains constant.

The maximum permissible effective (rms) current can be adjusted on the front panel, by using the “current limit” trimmer.

⇒ Section 5.3 “Setting the current limit”

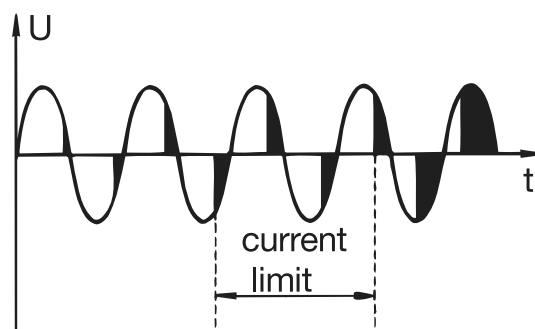

## 2 Operating modes

### 2.2 Burst-firing operation, for resistive loads

In this mode of operation, the power is regulated by changing the number of full-wave cycles of the supply line voltage which are switched on during each control period. This method is used for purely resistive loads which have a cold resistance that is roughly the same as the hot resistance.

Since switching only takes place at the zero-crossing points, this mode of operation produces very little RF-interference.

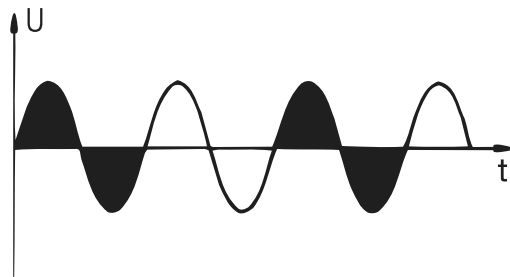

The internal switch S20 can be used to adjust the duty cycle to suit the system being controlled.

⇒ Section 6.2 “Adjustment switches S1 – 21 and pin headers X503 / X504”

Cycle time	S 20
Variable cycle time The control unit uses the shortest available cycle time (for fast control loops)	1
Fixed cycle time ( $\approx 500\text{ms}$ ) Used for transformer loads, slow control loops	2

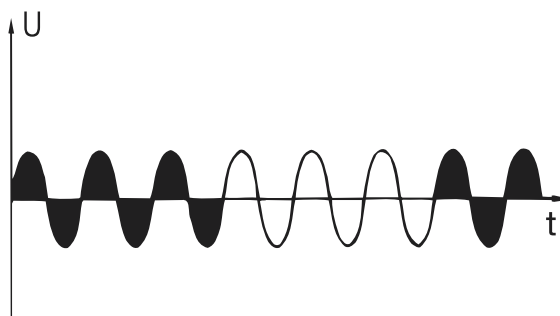

### 2.3 Burst-firing operation for transformer loads and loads with a high positive temperature coefficient TC (mixed operation)



It is not possible to change over to phase-angle control in this mode of operation.

#### Soft start

For the first switch-on of the thyristor power unit, or after being switched off by inhibiting the firing-pulses, after a supply line interruption, or if the setpoint was switched off for more than 8seconds, there will always be a short phase-angle controlled start (area a in the diagram).

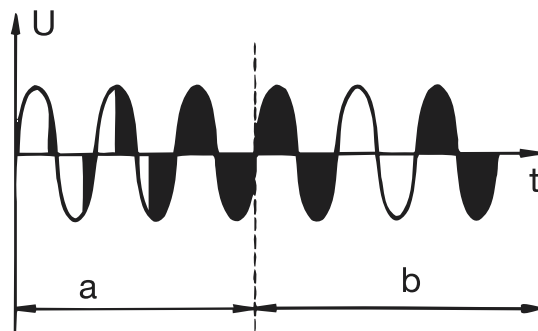

After this soft start, the controller switches over automatically to burst-firing operation if the given setpoint is larger than the minimum setpoint + 10% of the setpoint range (area b in the diagram).

Example:

Setpoint range 2 – 10V

The changeover to burst-firing operation takes place at

$$2V + 10\% \text{ of } 8V = 2V + 0.8V = 2.8V$$

After this changeover, the power output is regulated to follow the setpoint input provided.



If the power unit runs into current limiting<sup>1</sup> during the phase-angle controlled start, then the output is regulated according to the maximum current given by the current limit setting, even for low levels of the setpoint input.

1. with extra codes TR/TO

## 2 Operating modes

---

For transformer loads, the thyristor power unit operates in burst-firing mode with a cut-back (retarded) phase-angle for the first half-wave. The factory setting is an angle  $\alpha = 90^\circ$ . This value can be altered on the front panel over a range  $\alpha = 0 - 90^\circ$ .

⇒ Section 5.4 “Setting the phase angle for the first half-wave”



We recommend that this setting is not changed!

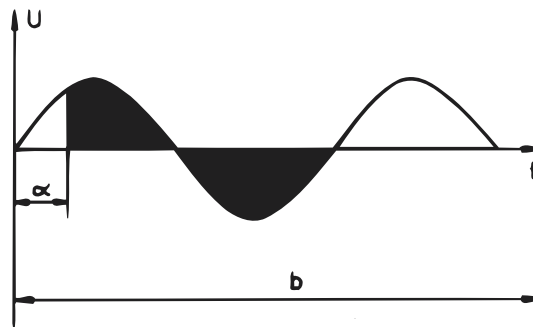

## 3.1 Important installation notes

### Safety regulations

- The choice of cable, installation and electrical connection of the instrument must meet the requirements of VDE 0100 “Regulations for the Installation of Power Circuits with nominal voltages below 1000 V AC” or the corresponding local regulations.
- Electrical installation must only be performed by properly qualified personnel.
- The unit must be completely disconnected from the supply line (on all poles) if there is a risk of contact with live parts during work on the unit.

### Fusing



- In the event of a short-circuit in the load circuit, the power unit is protected by the built-in semiconductor fuse.
  - ⇒ Section 8.2 “Replacing the semiconductor fuse”
- Do not connect any additional loads to the output load terminals.

### Interference suppression

- The electromagnetic compatibility (EMC) meets the standards and regulations cited in the technical data.
  - ⇒ Section 7 “Technical data”

### Wiring

Load and control cables should be laid separately, as far as feasible. The appropriate fuses for control circuitry (e.g. 2A, type Neozed) should be used to protect the wiring.

### Connections

- \* Check the data given on the nameplate (rated load voltage, load current) against the data for the system.
- \* Wire up the connections from supply line – thyristor power unit – load according to the wiring diagram, and check them
- \* If the economy circuit configuration is used, check that the rotary electrical field has clockwise phasing.
- \* Check the settings for the setpoint inputs
- \* Check the switch positions

### Supply voltage

- \* Connect the supply voltage for the control electronics as shown in the wiring diagram.
- \* Link “N/L2” to “V”, unless the economy circuit is being used (slave unit).

### Load connection

The electronic switching devices (2 antiparallel thyristors) are in circuit between the screw connections “U1” and “U2”.

### Phasing

The supply voltage for the control electronics and the load voltage must have the same phase.

- \* Terminal “L1” must be connected, via a control circuitry fuse, to the same supply potential as terminal “U1”!

## 3 Installation

---

### Switch-on sequence

The supply voltages for the load and control circuitry must be switched on at the same time.



In no circumstances should the supply voltage for the control electronics be switched on before the voltage for the load!

This is especially important for operating transformer loads and resistive loads with a large variation between hot and cold resistance!

### Control inputs

The control connections (inputs and outputs) are designed for safety separation from the supply line input (SELV). In order not to diminish this safety separation, all connected circuits must also have safety separation. The auxiliary voltages which are required must be safe extra-low voltages (SELV).



Connections must only be wired up by properly qualified personnel!

## 3.2 Filtering and interference suppression

In order to prevent radio-frequency interference, such as would occur with phase-angle control, electrical apparatus and systems must have interference suppression implemented.

The control electronics of the thyristor power units conforms to the EMC Directive EN 61 326.

However, modules such as thyristor power units have no use by themselves, but only as a component function within a system. For this reason, the load circuit of the power unit must have suitable interference suppression filters fitted by the system provider.

Specialist companies have appropriate ranges of filters available to deal with these problems. Such filters are normally supplied as complete modules that are ready to be connected up.

## 3.3 Installation site and climatic conditions

The installation site should be, as far as possible, free from vibration. Electromagnetic fields, caused by equipment such as motors and transformers, should be avoided. The ambient temperature at the installation site must be within the range 0 to 45 °C (measured about 100 mm below the unit) and the relative humidity must be  $\leq 75\%$ . The thyristor power unit is intended for use in dry rooms. The inside of the unit must be kept free from conductive dirt and corrosive gases.

The thyristor power unit must be mounted vertically, to ensure good convection cooling. If it is mounted in a switchgear cabinet, adequate ventilation must be provided. There must be at least 100 mm free space below, and 150 mm

above the unit. The thyristor power unit has enclosure protection IP00, and so it must be mounted in such a way that bodily contact is prevented (built-in unit).



The heatsink can become very hot in operation!

- Incorrect use**
- The unit is not suitable for installation in areas with an explosion hazard (Ex areas).
  - The installation site should be free from vibration, dust, and corrosive media.

- Ambient conditions**
- Side-by-side mounting of units is permitted
  - Relative humidity  $\leq 75\%$ , no condensation
  - Ambient temperature range: 0 to 45 °C  
Storage temperature range: -10 to 70 °C

### 3.4 Wall mounting

- \* Fix the aluminium mounting plate to the heatsink, using the cheese-head screws provided.
- \* Fix the thyristor power unit with its mounting plate to the wall, using four screws.

#### 3.4.1 TYA-110/3, 025..100

# 3 Installation

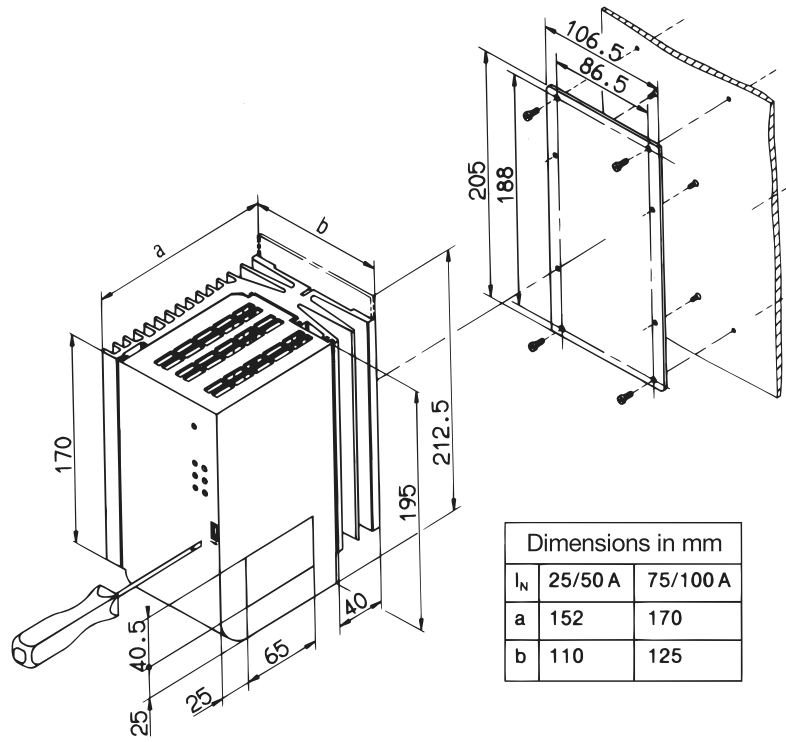

## 3.4.2 TYA-110/3,150 and TYA-110/3, 250

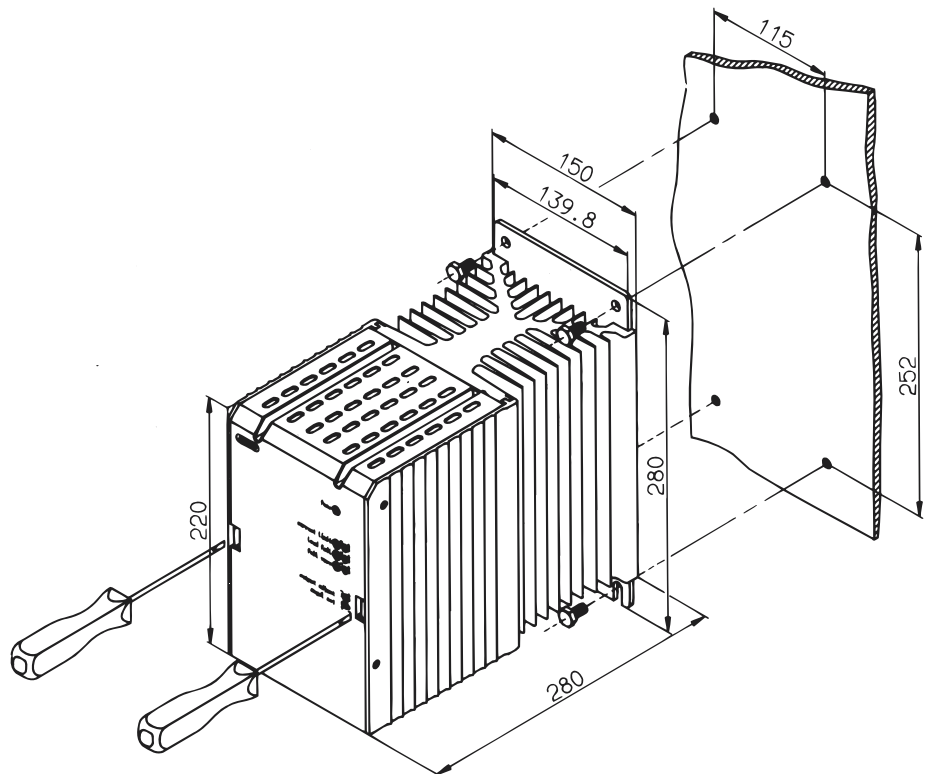

## 3.5 DIN rail mounting

- \* Fix the DIN rail
- \* Snap the thyristor power unit and its mounting plate onto a standard rail (to DIN EN 50 022) and lock it in place with the lever. This type of mounting is only possible for thyristor power units up to 50A rated current.

### 3.5.1 TYA-110/3, 025 ..100

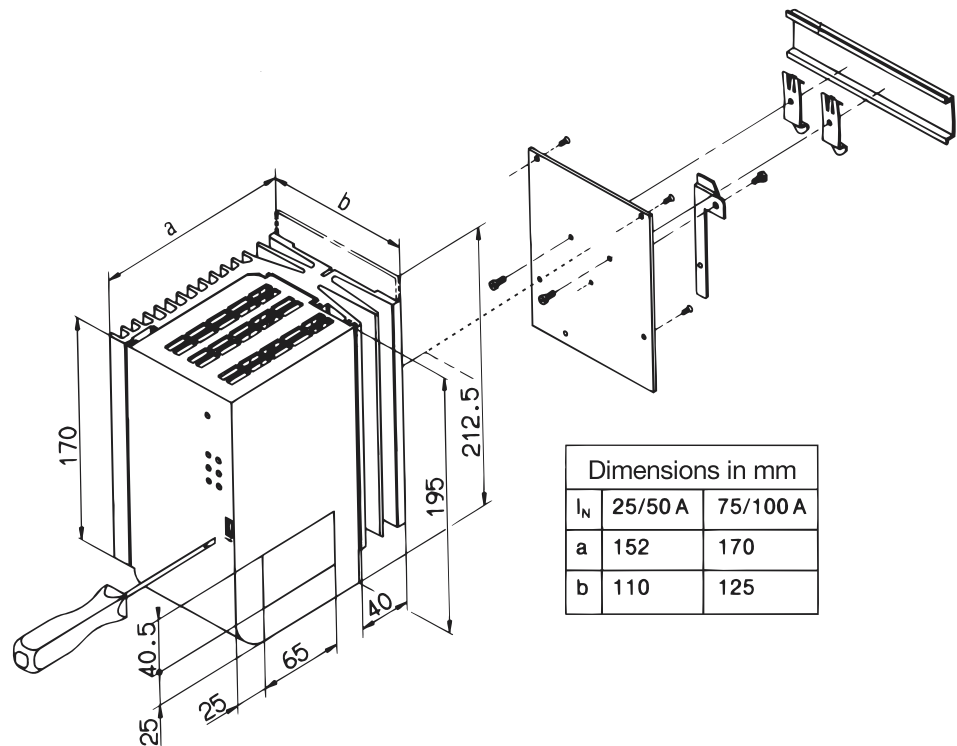

# 3 Installation

---

## 4 Electrical connection

### 4.1 Connection diagram

The diagram shows the various connections that are available at the plug-in screw terminals.

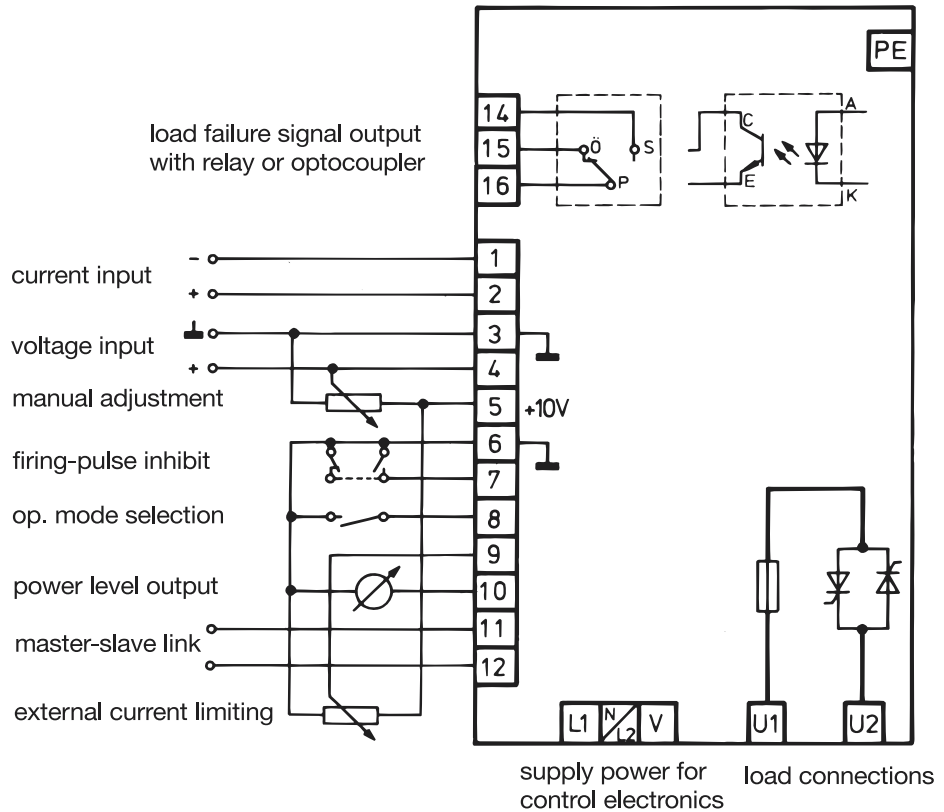

Only properly qualified personnel are permitted to make electrical connections!

- \* Disconnect the equipment completely (on all poles) from the supply line
- \* Connect the control cables (conductor cross-section 0.2 – 2.5 mm<sup>2</sup>) to the screw terminals. Use cable lugs to DIN 46 212 for the load connections.

#### Tools required

- 1 screwdriver, 3 mm blade (max.)
- 1 socket wrench, 10 mm (for TYA-110/3, 100)
- 1 socket wrench, 13 mm (for TYA-110/3,150 and TYA-110/3, 250)

# 4 Electrical connection

Connection for	Pin assignment	Symbol
Supply voltage for control electronics; link V to N/L2, unless economy circuit is being used	L1 (line / phase 1) N/L2 (neutral / phase 2) V	
Load connection	U1 U2	
Current input (differential input)	1- 2+	
Voltage input (referred to ground)	3⊥ 4+	
Logic input	1- 2+	
	3⊥ 4+	
	4+ 5 (+10V, 2mA)	
External manual adjustment with 5 kΩ potentiometer (via voltage input)	3 Start (⊥) 4 Slider 5 End (+10V, 2mA)	
Firing-pulse inhibit input $I_K \approx 1 \text{ mA}$ (make or break contact)	6⊥ 7+	
Load-failure output with relay, switching capacity 5A at 230 V AC, resistive load. Relay drops out if fault occurs. (extra code TR)	16 P pole 15 O break contact 14 S make contact	
Load failure output with optocoupler $I_{Cmax.} = 2 \text{ mA}$ $U_{CEO max.} = 32 \text{ V}$ (extra code TO)	15 Collector 16 Emitter	
External changeover of operating mode (phase-angle or burst-firing operation)	6⊥ 8+	
Actual (power) output 0 – 10V $I_{max} \approx 2 \text{ mA}$	10+ 6⊥	
Master-slave connection for master-slave economy circuit	6⊥ 11 12	
External current limiting with 5 kΩ potentiometer	5 Start (+10V, 2mA) 6 End (⊥) 9 Slider	

## 4 Electrical connection

### 4.1.1 Type TYA-110/3, 025, - 050, - 075, - 100, ...

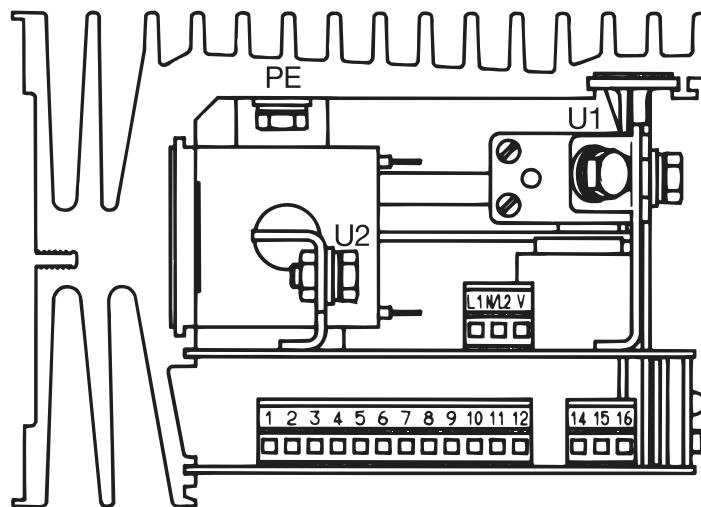

### 4.1.2 Type TYA-110/3, 150, ...

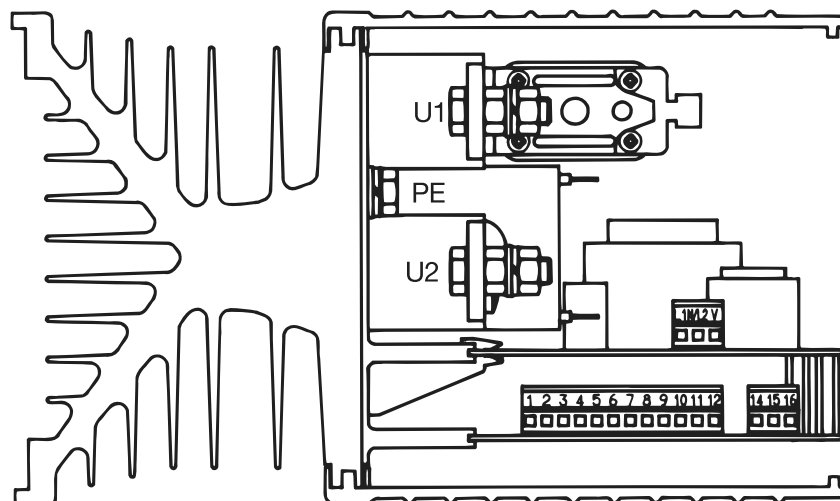

### 4.1.3 Type TYA-110/3, 250, ...

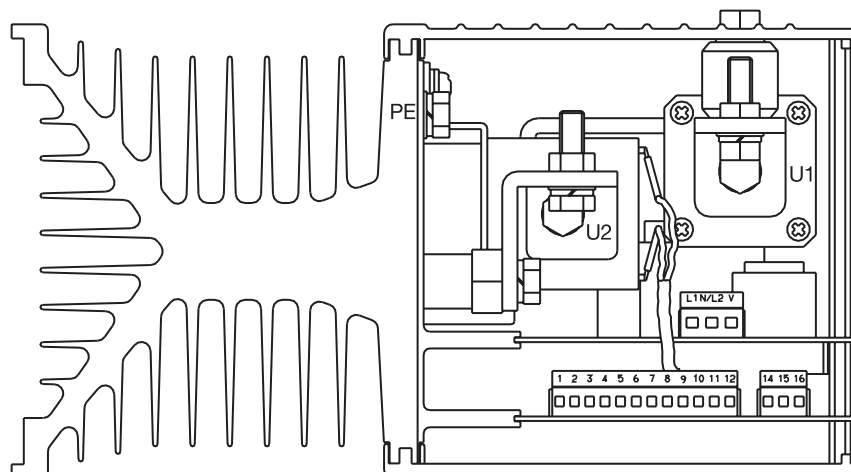

## 4 Electrical connection

### 4.2 Single-phase operation: line/phase – N

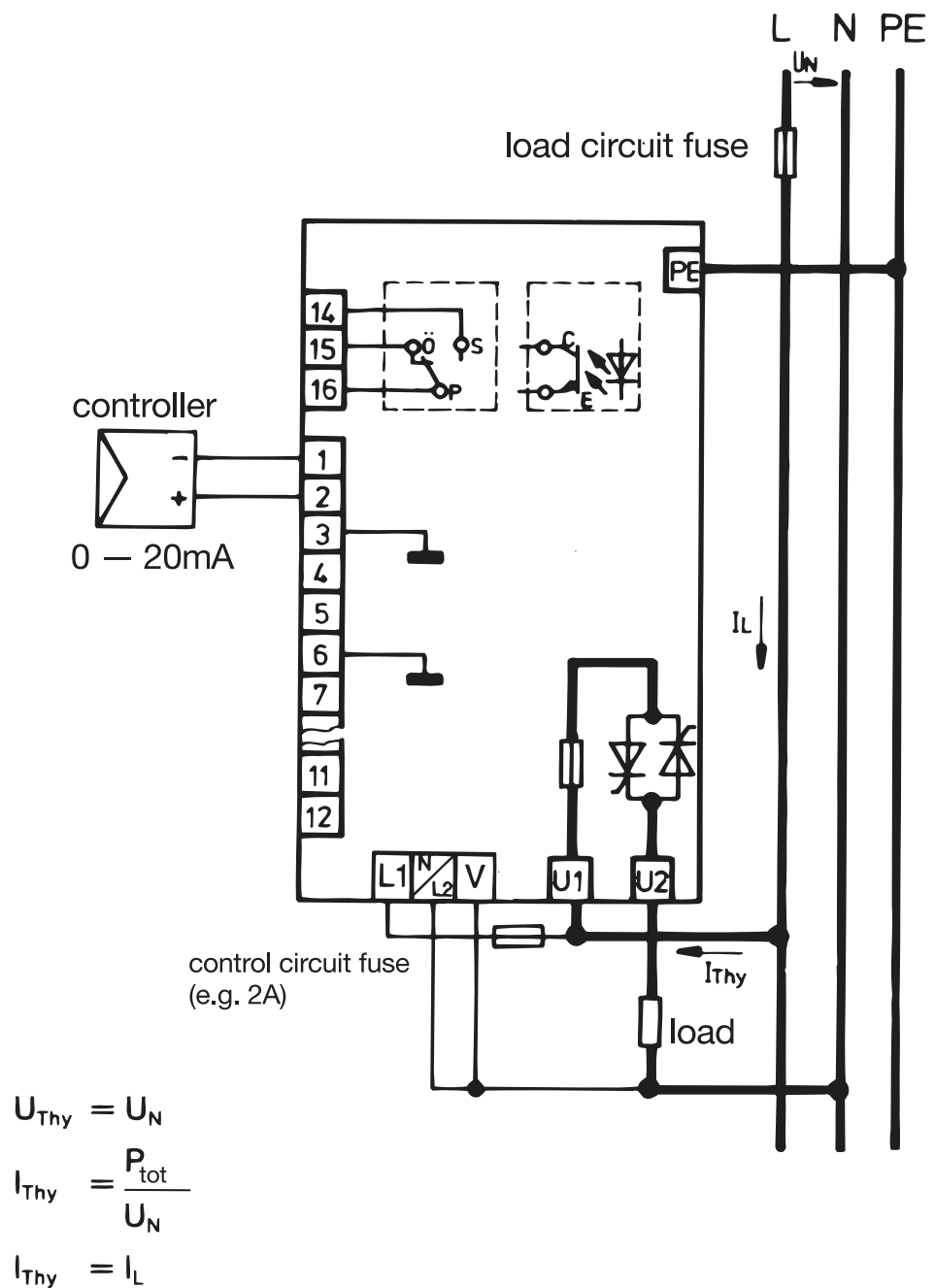

$U_L$  = phase-phase voltage

$P_{tot}$  = total controlled power

$U_N$  = phase-neutral voltage

$I_L$  = current in phase conductor

$U_{Thy}$  = voltage on thyristor power unit  $I_{Thy}$  = current in thyristor power unit

## 4 Electrical connection

### 4.3 Single-phase operation: phase – phase

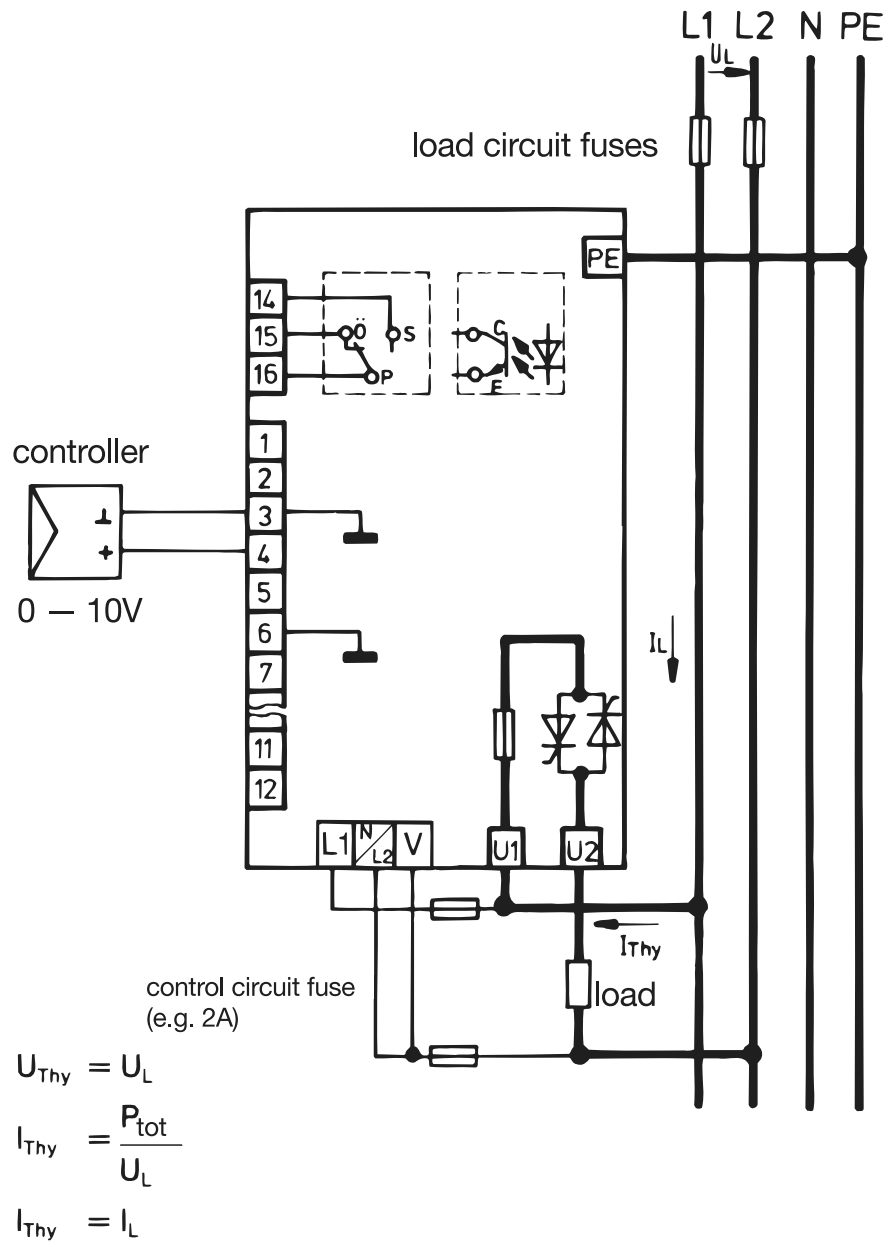

$U_L$  = phase-phase voltage

$P_{tot}$  = total controlled power

$U_N$  = phase-neutral voltage

$I_L$  = current in phase conductor

$U_{Thy}$  = voltage on thyristor power unit

$I_{Thy}$  = current in thyristor power unit

# 4 Electrical connection

## 4.4 Star configuration: with star point connected to N

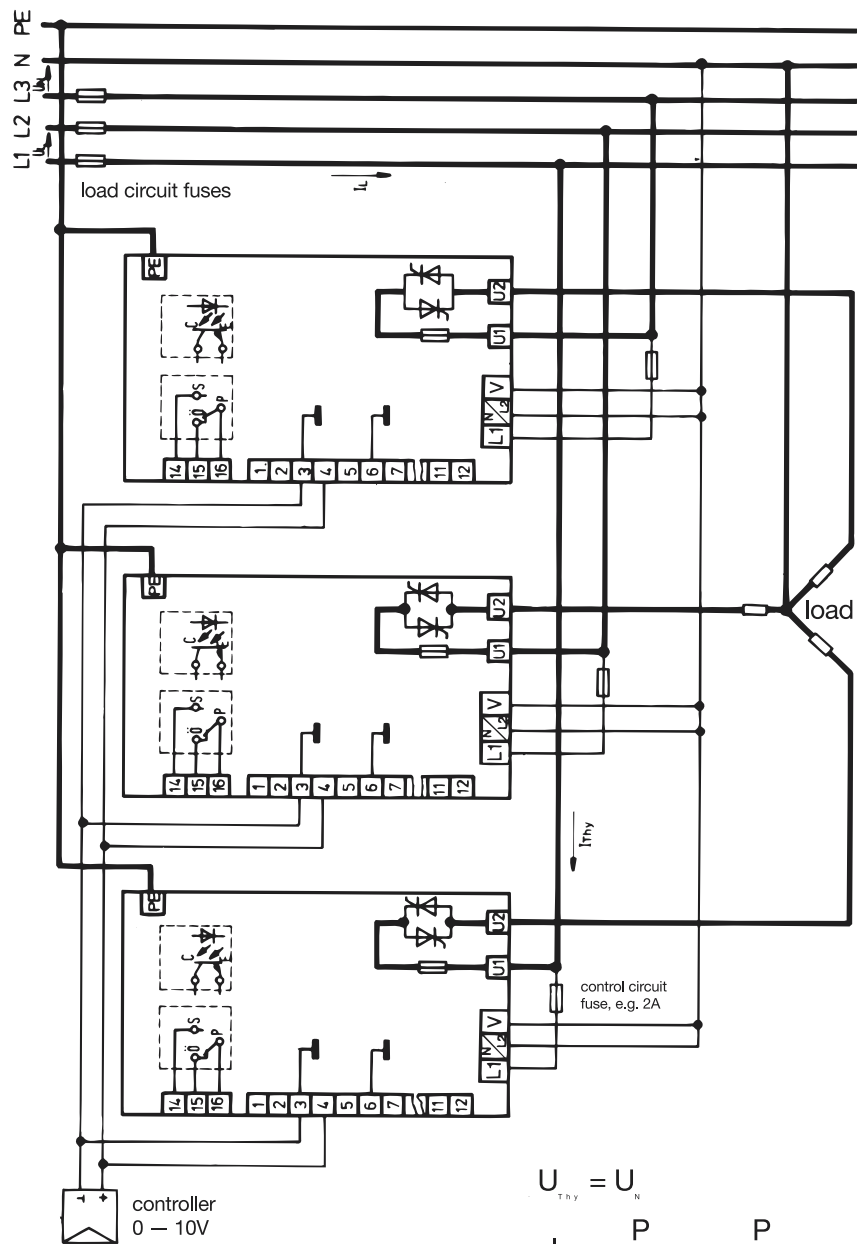

$$U_{Thy} = U_N$$

$$I_{Thy} = \frac{P_{tot}}{3 \cdot U_N} = \frac{P_{tot}}{\sqrt{3} \cdot U_L}$$

$$I_{Thy} = I_L$$

$U_L$  = phase-phase voltage

$P_{tot}$  = total controlled power

$U_N$  = phase-neutral voltage

$I_L$  = current in phase conductor

$U_{Thy}$  = voltage on thyristor power unit     $I_{Thy}$  = current in thyristor power unit

## 4.5 Open delta configuration (six-wire circuit)

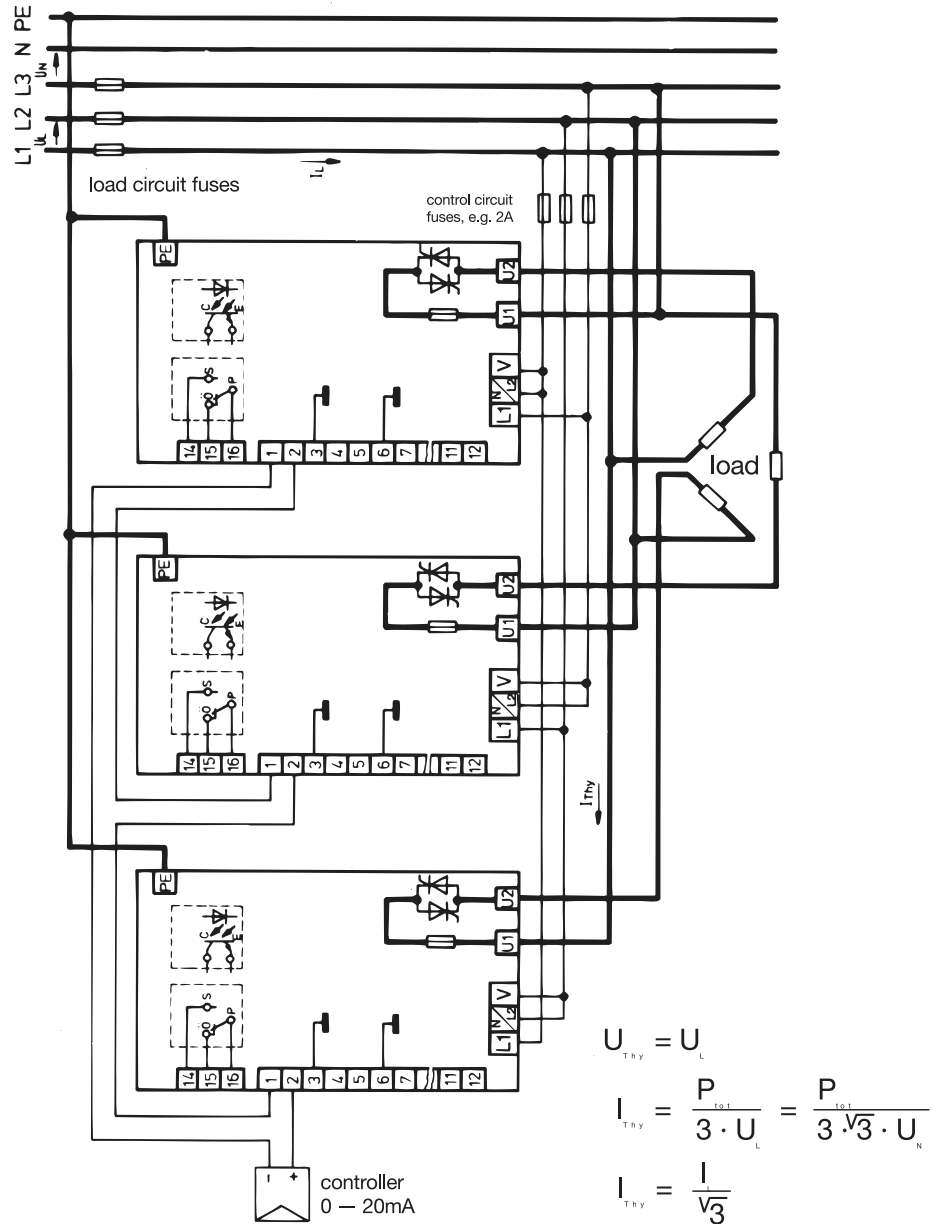

$U_L$  = phase-phase voltage

$U_N$  = phase-neutral voltage

$U_{Thy}$  = voltage on thyristor power unit

$P_{tot}$  = total controlled power

$I_L$  = current in phase conductor

$I_{Thy}$  = current in thyristor power unit

# 4 Electrical connection

## 4.6 Free-running economy circuit, purely resistive loads

Only possible in burst-firing mode with P-control

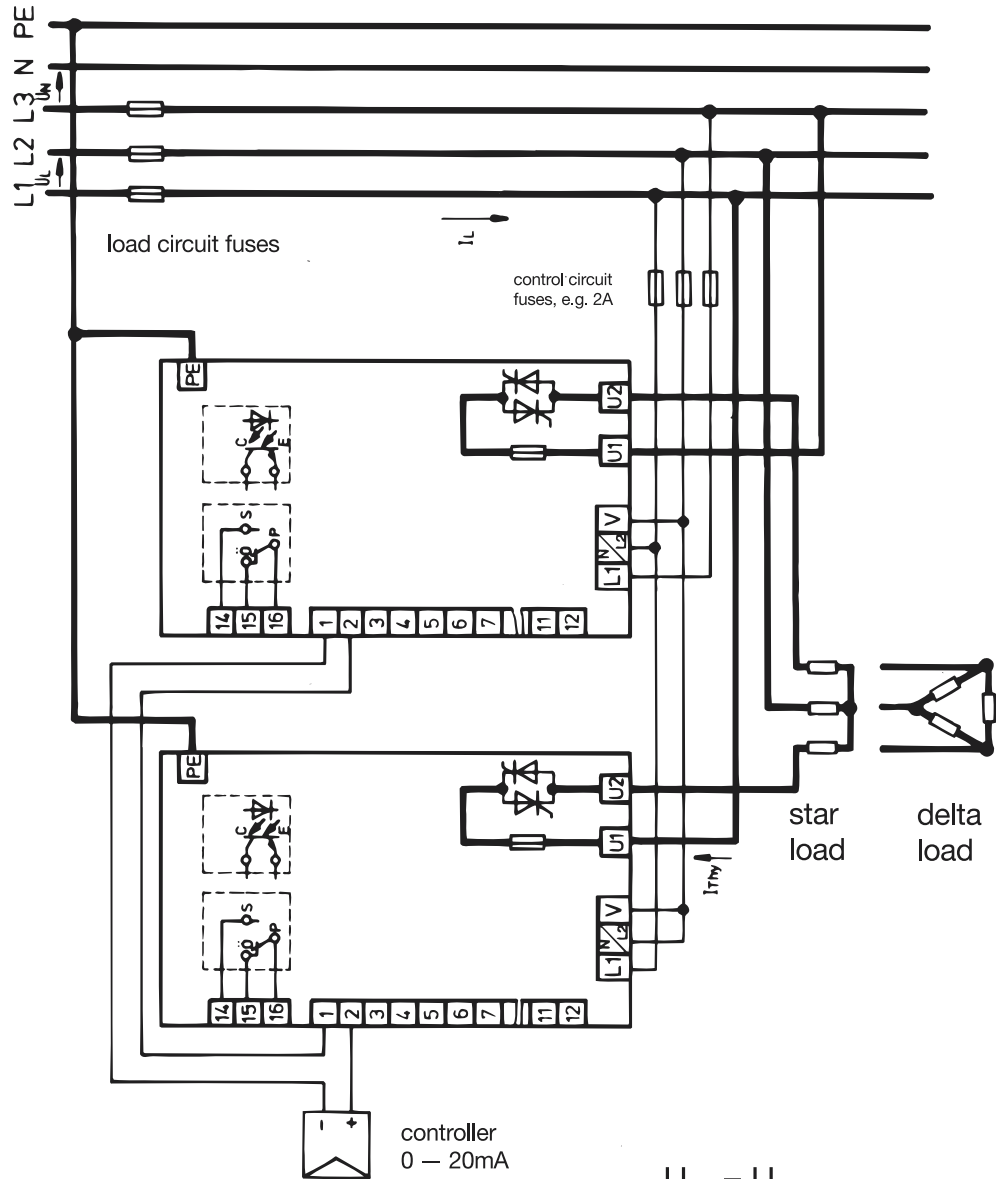

### CAUTION

Check that the electrical field has right-hand (clockwise) rotation. Thyristor units must be dimensioned for the phase-phase voltage.

$$U_{Thy} = U_L$$

$$I_{Thy} = \frac{P_{tot}}{3 \cdot U_N} = \frac{P_{tot}}{\sqrt{3} \cdot U_L}$$

$$I_{Thy} = I_L$$

$U_L$  = phase-phase voltage

$P_{tot}$  = total controlled power

$U_N$  = phase-neutral voltage

$I_L$  = current in phase conductor

$U_{Thy}$  = voltage on thyristor power unit  $I_{Thy}$  = current in thyristor power unit

## 4.7 Master-slave economy circuit, with resistive/inductive loads

Only possible in burst-firing mode

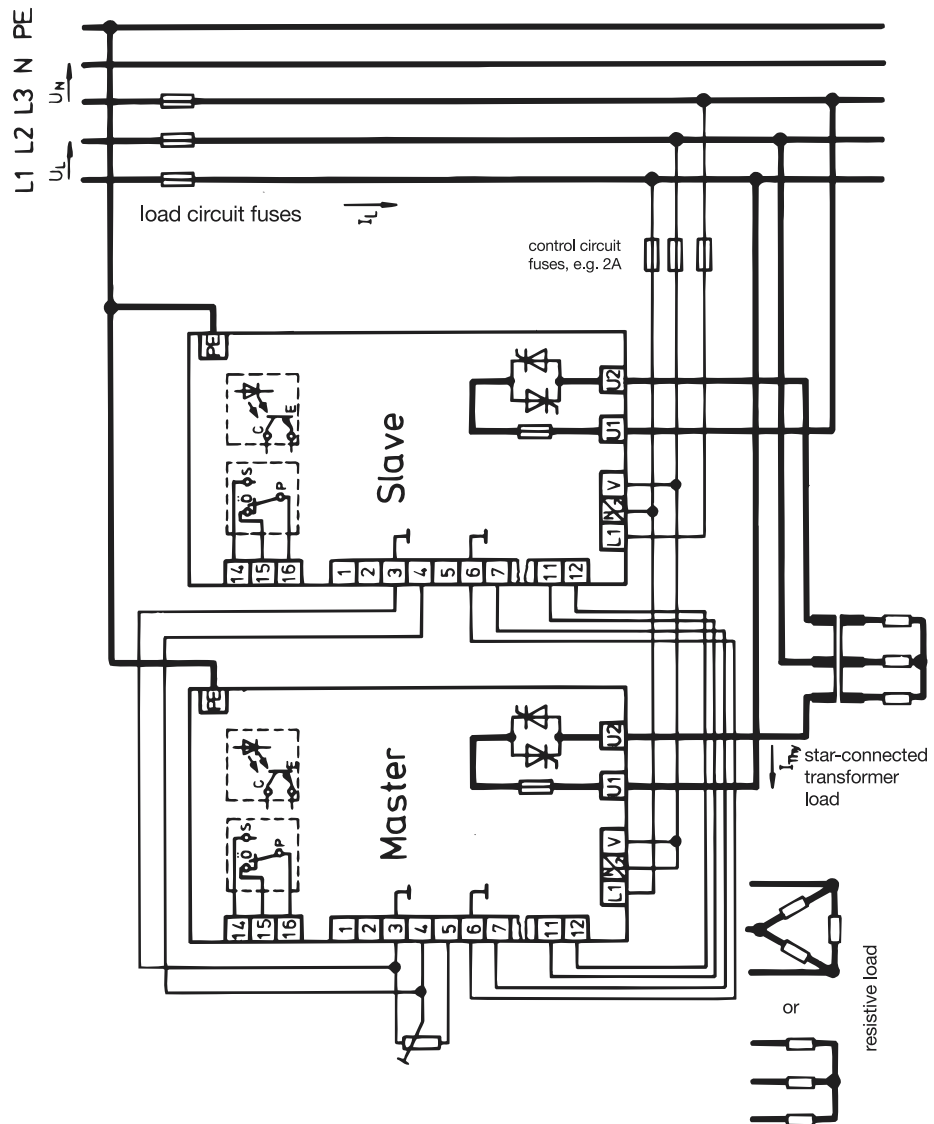

### CAUTION

Check that the electrical field has right-hand (clockwise) rotation. Thyristor units must be dimensioned for the phase-phase voltage.

$$U_{Thy} = U_L$$

$$I_{Thy} = \frac{P_{tot}}{3 \cdot U_N} = \frac{P_{tot}}{\sqrt{3} \cdot U_L}$$

$$I_{Thy} = I_L$$

$U_L$  = phase-phase voltage

$U_N$  = phase-neutral voltage

$U_{Thy}$  = voltage on thyristor power unit

$P_{tot}$  = total controlled power

$I_L$  = current in phase conductor

$I_{Thy}$  = current in thyristor power unit

## 4 Electrical connection

---

## 5.1 Adjust control input (full wave)

The trimmer (7) “full wave” on the front panel can be used to adjust the thyristor power unit so that the 100% (full wave) firing point is reached at the maximum output signal of the preceding controller.

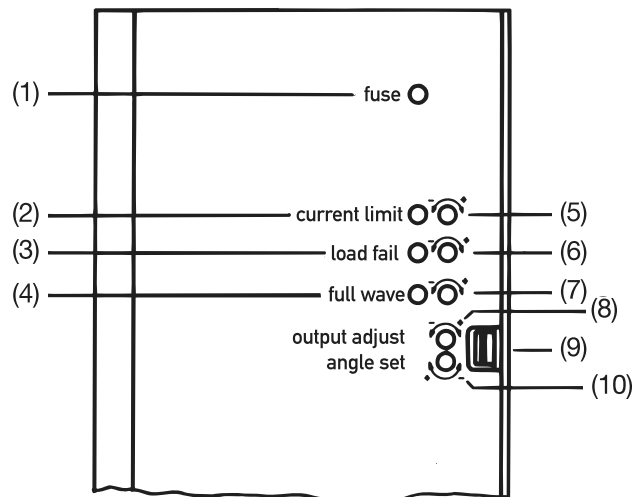

### 5.1.1 Setting the maximum power output

- \* Apply the maximum controller output signal
- \* Turn the “full wave” trimmer clockwise or counter-clockwise until the green LED for “full wave” just light up in phase-angle control, and does not light up in burst-firing mode.



When using a logical control output (e.g. from a single-setpoint controller) the “full wave” trimmer must be turned fully clockwise.

### 5.1.2 Input signal attenuator

- \* Turning the “full wave” trimmer counter-clockwise limits the maximum power output of the thyristor power unit.

When using the **free-running economy circuit**, both thyristor power units must be adjusted as described above.

When using the **master-slave economy circuit**, the adjustment is only made on the master power unit.

- ⇒ Section 4.6 “Free-running economy circuit, purely resistive loads” und Section 4.7 “Master-slave economy circuit, with resistive/inductive loads”

# 5 Commissioning

## 5.2 Setting the base load

A base load can be set, in addition to the analog current input and the potentiometer input. Since these input signals are added together, the input signal gain must be corrected by adjusting the “full wave” trimmer (7).

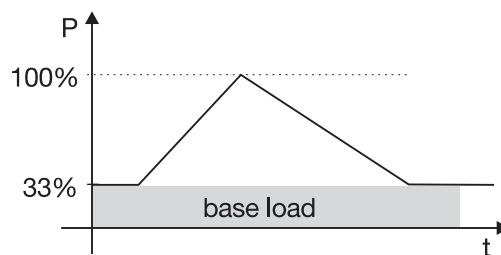
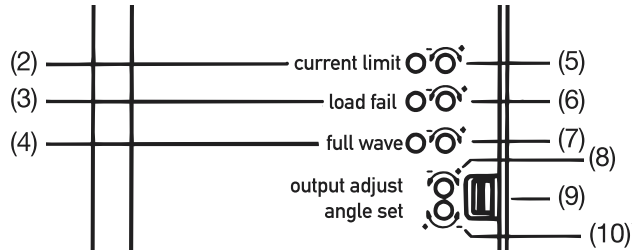

For instance, if a heating system is to be operated with a 33% base load, with the other 66% of the output being regulated by the controller, then the procedure is as follows:

Calculate the reduction factor of the controller signals.

In this example it would be  $100\% : 66\% = 1.5$ .

Multiply this factor by the intended base load setting.

In this case:  $1.5 \times 33\% = 50\%$ .

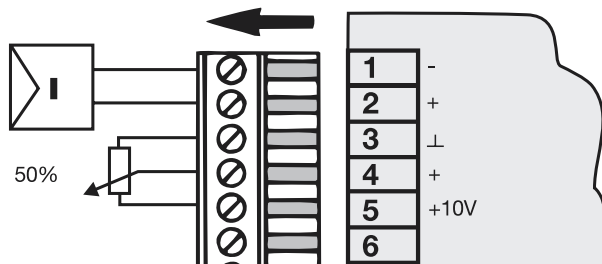

The factor 0.5 means that the external potentiometer must be set to 50% of the full-scale value.

Adjustment:

- \* Set the potentiometer to the calculated fraction of the full scale (e.g. 50%)
- \* Apply the maximum current (e.g. 20mA) to the current input
- \* Turn the “full wave” trimmer clockwise or counter-clockwise until the green LED for “full wave” just light up in phase-angle control, and does not light up in burst-firing mode.

## 5.3 Setting the current limit

### Internal current limiting

Current limiting is only possible in the phase-angle mode of control.

- \* The trimmer (5) “current limit” on the front panel can be used to limit the effective (rms) value of the load current over a range from 10 – 100% of the rated current for the thyristor control unit ( $I_{ThyN}$ ).  
1.5 turns clockwise correspond to increasing the threshold by about 10% of the rated current.

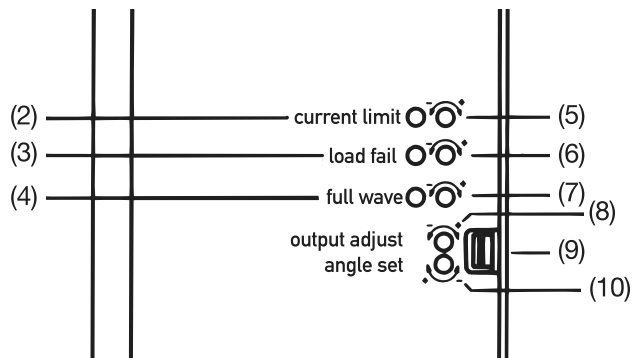

The red LED lights up when the current limit is reached. Current limiting is achieved by limiting the “ON” phase angle so that the set value for effective current is not exceeded.

### External current limiting

An external voltage signal in the range 0 – 10 V can be applied to Terminal 9 to influence the internal current limit  $I_{max}$  set by the “current limit” trimmer.

0V means no effect, 10 V means the maximum effect (the threshold is reduced to the smallest value possible).

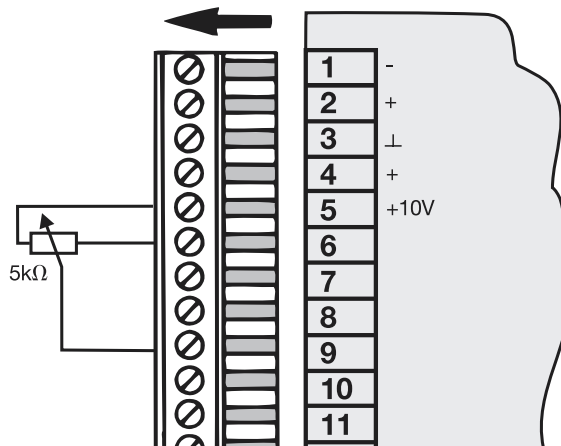

# 5 Commissioning

## 5.3.1 Alteration of the current limit $I_{max}$ , as a function of the voltage on Terminal 9

With an internal limit of, for example,  $I_{max} = 0.8 \times I_{Thy}$ , the external range of variation is only 0 to 8V.

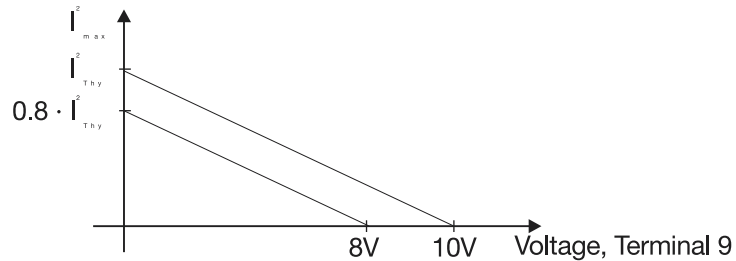

## 5.4 Setting the phase angle for the first half-wave

In the mode “burst-firing with phase-angle controlled start” the thyristor power unit retards the firing point for the first half-wave after the start in burst-firing mode.

The factory setting is an angle  $\alpha = 90^\circ$  (electrical). This value can be altered over the range  $\alpha = 0 - 90^\circ$  by the trimmer (10) “angle set”.

The factory setting will be satisfactory in most cases.

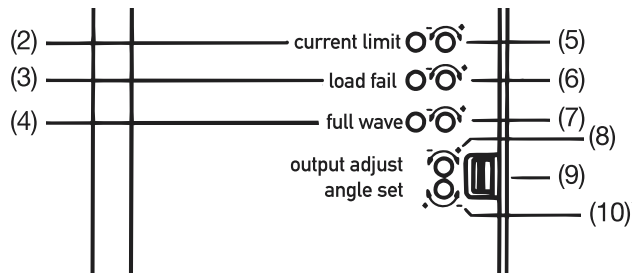

If it is nevertheless necessary to make an adjustment, then the minimum switch-on current at the start of the burst is the criterion for setting the angle  $\alpha$ .

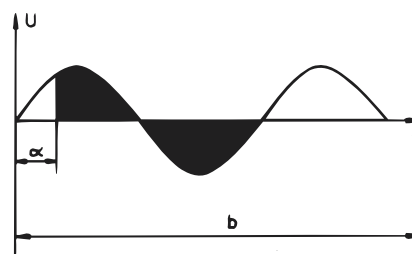

Counter-clockwise (left) = advance the firing angle  $\alpha$

Clockwise (right) = retard the firing angle  $\alpha$

## 5.5 Load and part-load failure monitoring

This function is only available with the extra code TR or TO. If there is a change in the load resistance during operation, this is detected and indicated by the part-load failure monitoring.

The signal output is available either as a floating contact (extra code TR) or an optocoupler (extra code TO). If a part-load fault occurs, the relay drops out or the collector-emitter of the optocoupler goes high-impedance. The signal output is also produced if there is a blown fuse.

The response threshold can be set by the front-panel trimmer (6) “load fail” to a value between 20 and 100% of the rated current for the power unit. Part-load failure monitoring functions in all operating modes.

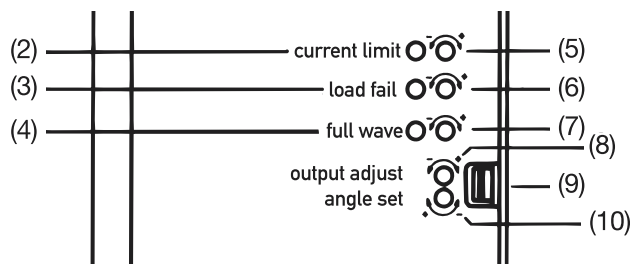

The load/part-load failure monitoring (low current monitoring) can also be used for overcurrent monitoring. To implement this, remove the two jumpers on pin header X504, next to the “angle set” trimmer, turn them through 90° and replace.

⇒ Section 6.2 “Adjustment switches S1 – 21 and pin headers X503 / X504”

### 5.5.1 Setting the threshold for load failure indication

(Factory setting is 50% of rated load)

- \* Connect up the load
- \* Apply full power
- \* Set the “load fail” trimmer so that the yellow “load fail” LED just goes out.
  - turn clockwise (right) = LED lights up
  - turn counter-clockwise (left) = LED goes out
- \* If necessary, the threshold can be reduced by further counter-clockwise rotation, whereby 1.5 turns of the trimmer potentiometer correspond to a load change of about 10% of the rated current for the thyristor power unit.

If the load current is below the rated current of the power unit, then the number of turns required is reduced in the same proportion.

If load current  $I_L < 0.5 \times I_{ThyN}$  then internal switch S15 must be in position 0.

⇒ Section 6.3 “Summary of possible settings”

# 5 Commissioning

Alternative setting:

Simulate a load failure, and then adjust the “load fail” trimmer so that the yellow “load fail” LED just lights up.

## 5.5.2 Setting for master-slave and free-running economy circuit



When using master-slave and free-running economy circuits, the settings must be made in both thyristor power units.



The smallest change of resistance that can be detected is 5 % of the nominal load resistance (10 % in an economy circuit).

## 5.6 External changeover of operating modes

For this to be possible, an external switch must be wired between Terminal 8 and Terminal 6.

Switch	Operating mode
open	burst-firing mode
closed	phase-angle control

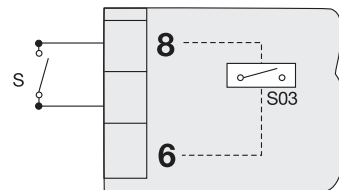

The external switch can only be used to change from burst-firing to phase-angle control when the internal switch S3 is open, since this switch is in parallel with the external switch S.

If the switches S12 and S13 are closed, an external changeover to phase-angle control is not possible.

⇒ Section 6.3 “Summary of possible settings”

## 5.7 Blown fuse indication

If a short-circuit occurs, the built-in semiconductor fuse switches within half a supply cycle, to protect the thyristors. When the fuse is blown, the “fuse” LED lights up,

⇒ Section 8.2 “Replacing the semiconductor fuse”

With extra code TR or TO, an output signal is also available.

⇒ Section 4.1 “Connection diagram”

### 6.1 Opening the housing



Adjustments must only be made while the unit is disconnected from the supply power!

It is easier if these adjustments are carried out before the unit is installed.

- \* Use a screwdriver to lever the spring fixing lug outwards.  
On the 150 A and 250 A versions: press both spring lugs inwards.
- \* Pull off the cover from the front.

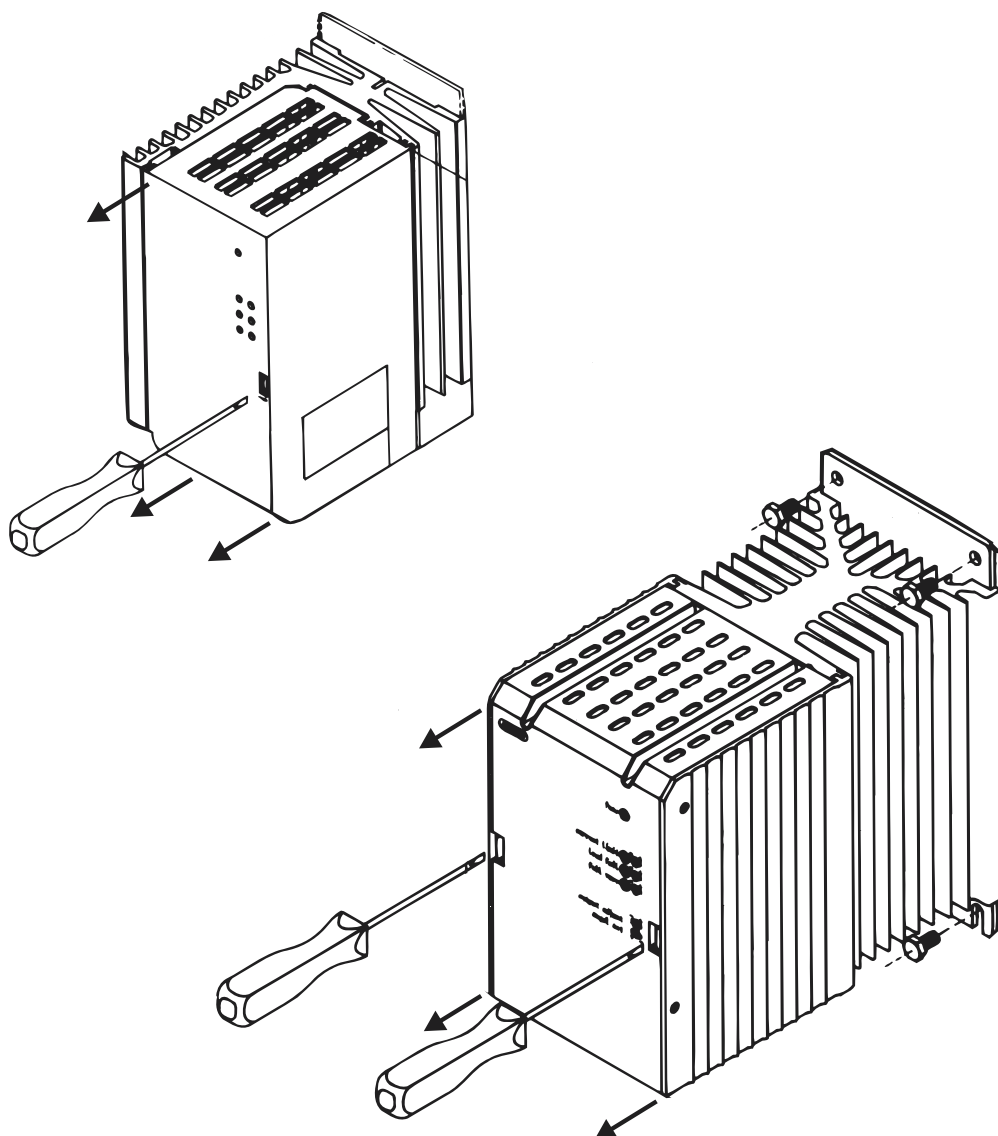

## 6 Settings

---

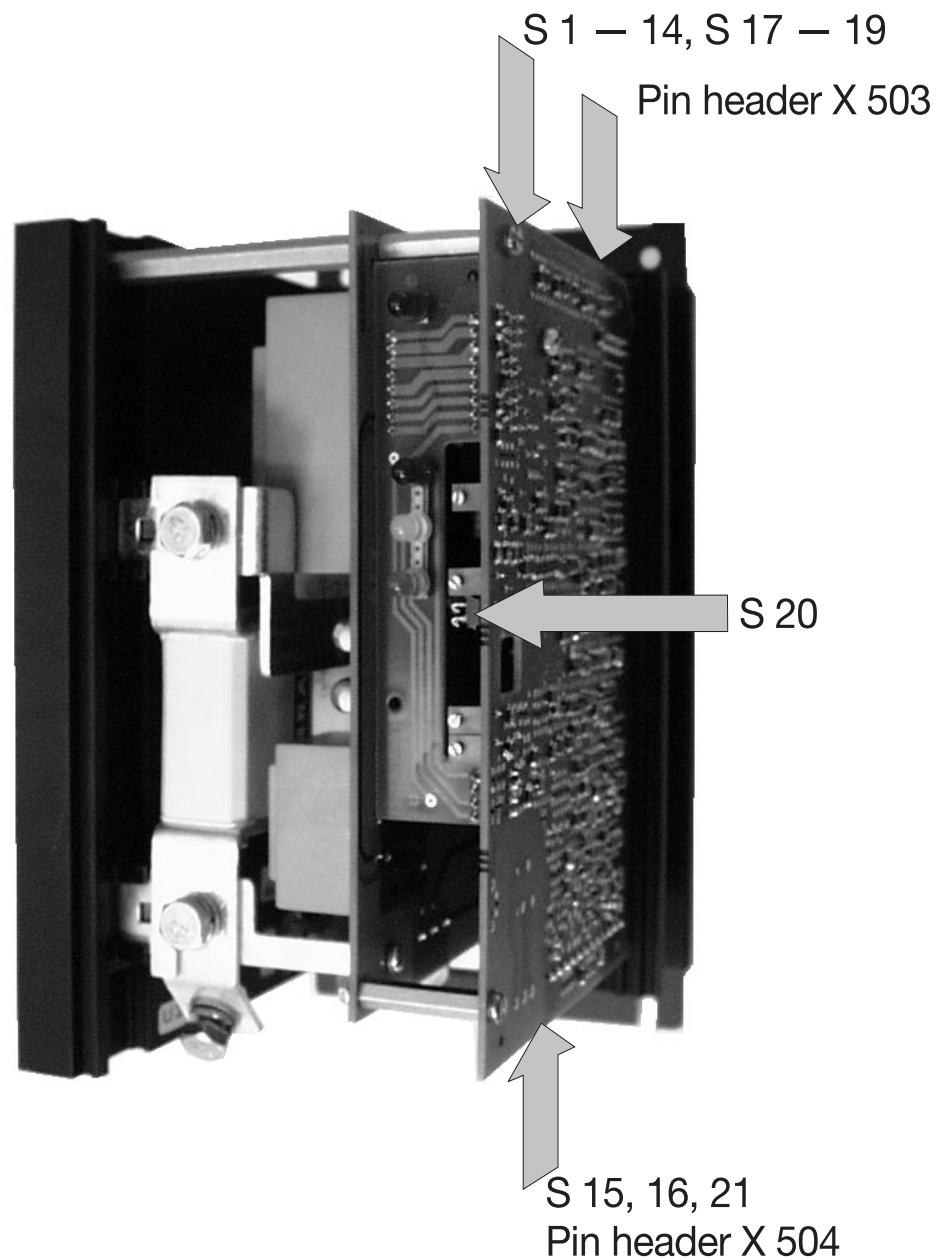

### 6.2 Adjustment switches S1 – 21 and pin headers X503 / X504

The switches S1 to 21 can be found on the back of the printed circuit board.



It is easier to access switches S15, S16 and S21 if the plug-in screw terminals are first pulled off downwards.

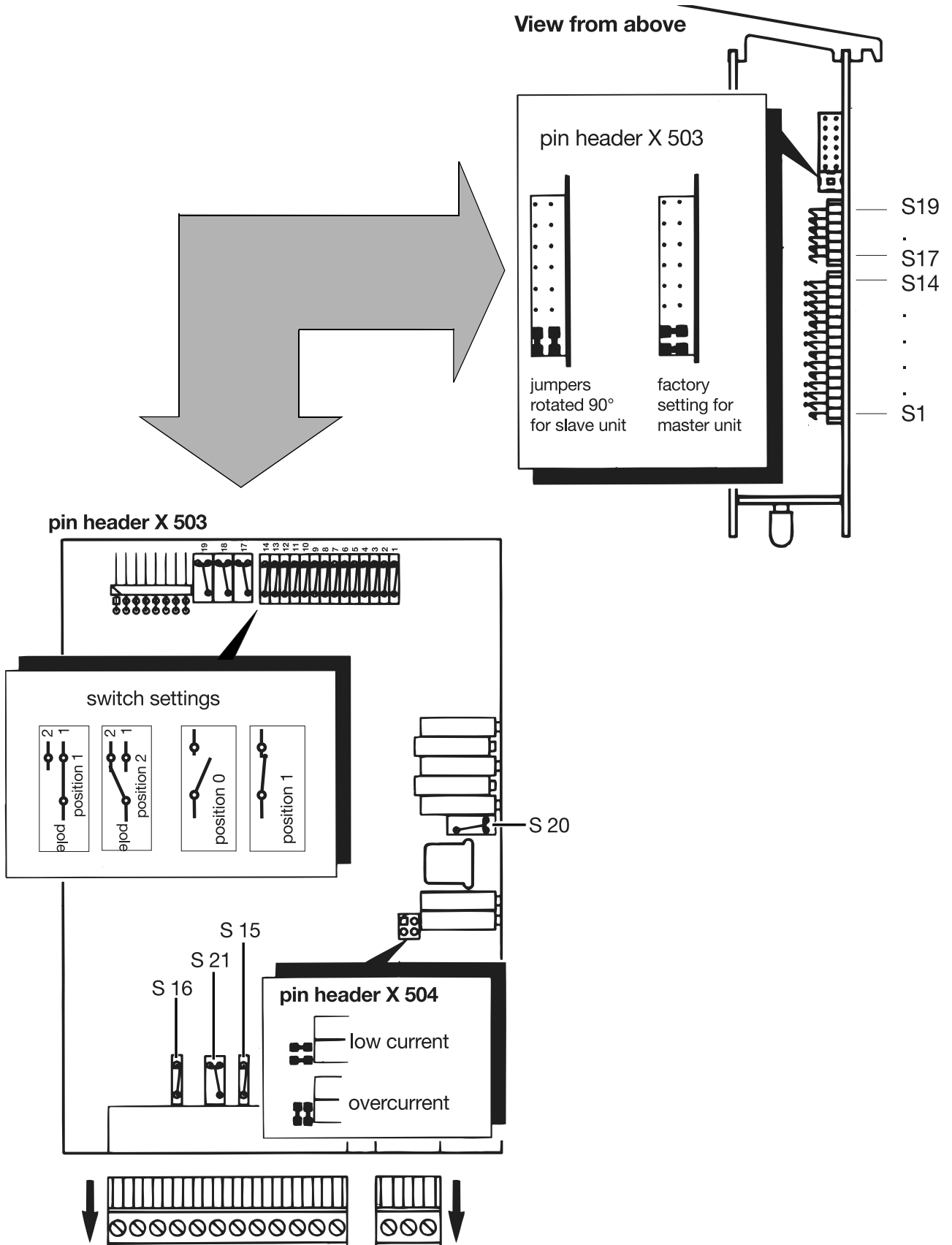

# 6 Settings

## 6.3 Summary of possible settings

Switch position																					
	1	2	3	4	5	6	7	8	9	10	11	12	13	14	15	16	17	18	19	20	21
Switch number <sup>1</sup>	1	2	3	4	5	6	7	8	9	10	11	12	13	14	15	16	17	18	19	20	21
factory setting	1	0	0	1	0	0	1	0	0	1	0	0	0	1	1	0	1	1	1	1	1
job-specific setting																					
<b>Control input</b>																					
0 – 20mA	1	0														0			1		
4 – 20 mA	0	0														0			2		
0 – 10V	1	0														0			1		
2 – 10V	0	0														0			2		
0 – 5V	1	0														1			1		
1 – 5V	0	0														1			2		
Logic signals 0/10V, 0/5V, 0/20mA or floating contact	0	1														1			2	1	
<b>Subsidiary control loop</b>																					
v <sup>2</sup>				1	0	0															
P				0	1	0															
i <sup>2</sup>				0	0	1															
<b>Actual power output</b>																					
v <sup>2</sup>							1	0	0												
P							0	1	0												
i <sup>2</sup>							0	0	1												
<b>Load current adaptation I<sub>L</sub></b>																					
I <sub>L</sub> < 0.5 · I <sub>ThyN</sub>																0					
I <sub>L</sub> ≥ 0.5 · I <sub>ThyN</sub>																1					
<b>Firing-pulse inhibit</b>																					
-external make contact																					1
-external break contact																					2
<b>Operating mode:</b>																					
<b>Phase-angle control</b>																					
for transformer/resistive load			1							1	0	0	0	1			1	1			
<b>Burst-firing mode:</b>																					
■ for resistive load			0							1	0			1			1	1			
■ for transformer load			0							0	1	1	1	1			1	1		2	
- R ≈ constant												0	0								
- $\frac{R_w}{R_K} > 1$ (soft start)												1	1								
- fixed cycle (500ms)																				2	
- variable cycle																				1	
<b>Economy circuit (free-running)</b>																					
■ for resistive load			0	0	1	0				1	0	0	0	1			1	1			
<b>(Master-slave)</b>																					
-master, resistive load			0							1	0			1			1	1			1
-slave <sup>2</sup> , resistive load			0							1	0			0			2	2			1
-master, transformer load			0							0	1	1	1	1			1	1		2	1
-Slave <sup>2</sup> , transformer load			0							0	1	1	1	0			2	2		2	1

1. S5, S6, S8, S9, S15 only have an effect with extra code TR or TO.

2. The jumpers on pin header X503 must be turned through 90°. Section 6.2 "Adjustment switches S1 – 21 and pin headers X503 / X504". A changeover to phase-angle control is not possible for burst-firing mode with a transformer load and soft start.

⇒ Section 2.3

## 6.4 Control inputs

The internal switches S1, S2, S16, S19, S20 can be used to adapt the thyristor power unit to suit the available control signal (controller output signal). There are separate voltage and current control inputs. The current inputs (+,-) are designed for a differential current signal, i.e. they can have a common potential that is up to 10V above or below the ground reference potential ( $\perp$ ). If the current and voltage inputs are used simultaneously, they have an additive effect. Both **analog** and **logical** controller output signals may be used.

Control signal		Internal switch				
Signal start	Signal end	S1	S2	S16	S19	S20
0 mA	20 mA	1	0	0	1	
4 mA	20 mA	0	0	0	2	
0 V	10 V	1	0	0	1	
2 V	10 V	0	0	0	2	
0 V	5 V	1	0	1	1	
1 V	5 V	0	0	1	2	
logic levels 0/10V 0/5V, 0/20mA or floating contact		0	1	1	2	1

### Analog control inputs

The thyristor power unit can be operated by the following signals (for analog power regulation):

- voltage signal (Terminals 3, 4)
- current signal (Terminals 1, 2)
- 5 k $\Omega$  potentiometer (Terminals 3, 4, 5)

A 10 V source is provided at Terminal 5 for use with a potentiometer. The switch settings are the same as for a 0 – 10 V signal.

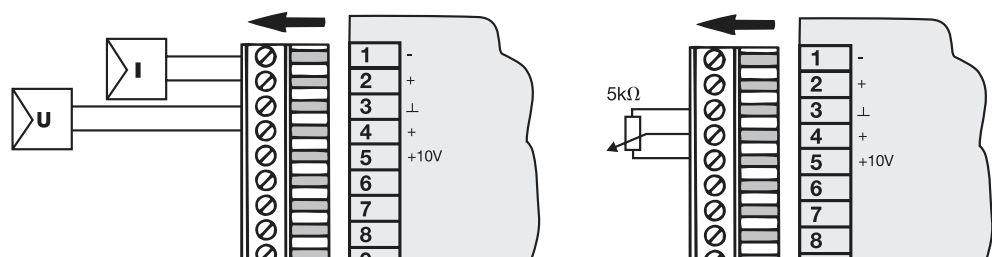

# 6 Settings

## Logic control inputs

The thyristor power unit can also be operated by the following logical signals (e.g. two-state/single-setpoint controller outputs):  
(switching pulse bursts on or off):

- current signal 0/20mA (Terminals 1, 2)
- voltage signal 0/10V (Terminals 3, 4)
- floating contact (Terminals 4, 5)

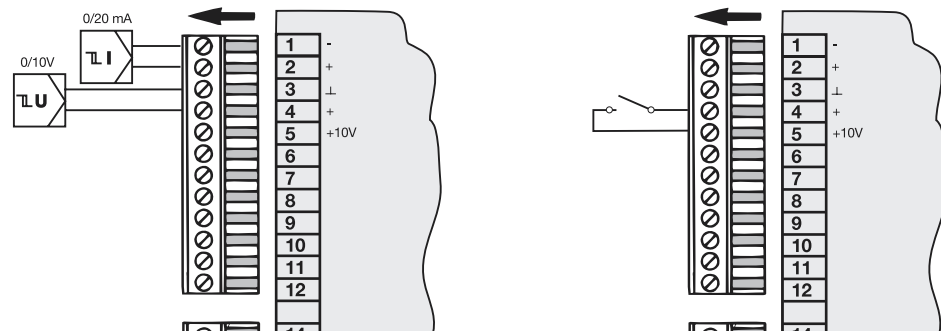

### 6.4.1 Combinations of external potentiometer and electronic controller

#### Controller with current output

The voltage input (Terminals 3, 4) can be used together with the internal 10 V source and a 5 kΩ potentiometer to provide manual setting.

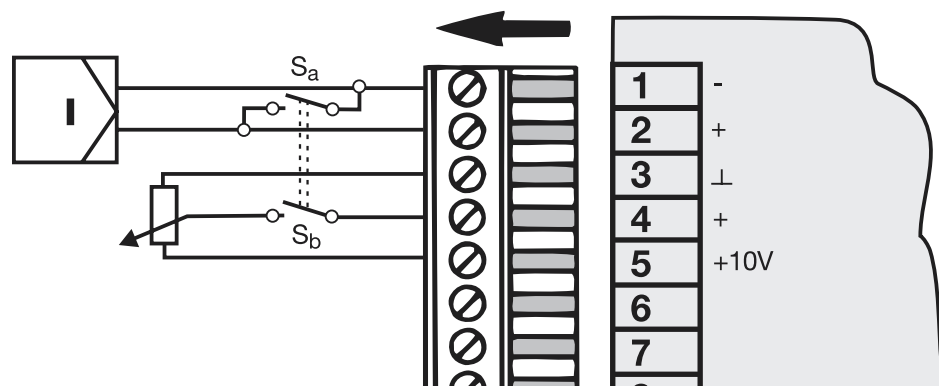

Switch	S <sub>a</sub>	S <sub>b</sub>
Automatic	open	open
Manual	closed	closed



To prevent unintended overdriving on the changeover to manual operation, S<sub>a</sub> should be mechanically coupled to S<sub>b</sub>. Otherwise the two signal sources will be added together for a moment.

## Controller with voltage output

This only uses the voltage input of the thyristor power unit. A 5 kΩ potentiometer is required on Terminals 3 and 5 for manual operation.

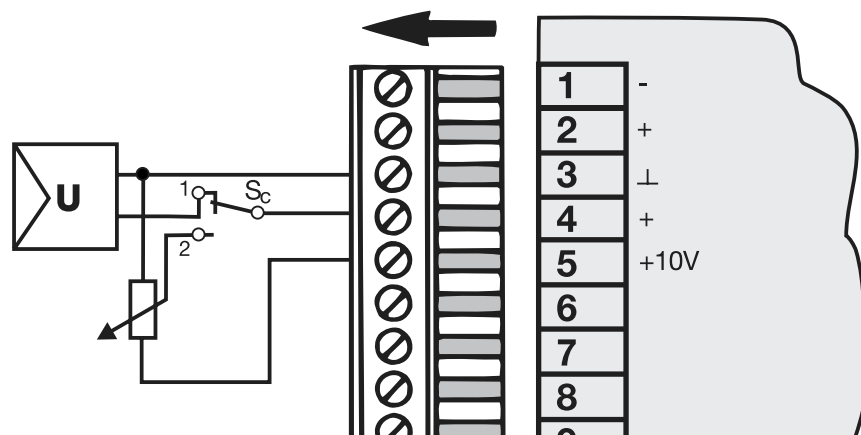

Switch	$S_c$
Automatic operation	position 1
Manual operation	position 2

## 6.5 Subsidiary control loops

Subsidiary control loops are primarily used to eliminate or compensate external disturbances, such as supply-line fluctuations and changes in resistance which would have a negative effect on the regulation. A subsidiary  $V^2$  control loop is set up ex-factory. With extra code TR or TO this can be changed to P or  $I^2$  control. The free-running economy circuit **must** operate with a P control loop.

⇒ Section 6.2 “Adjustment switches S1 – 21 and pin headers X503 / X504”



With P or  $I^2$  control loops (extra code TR/TO) a load current adaptation must be made for operating currents that are less than half the rated load current.

⇒ Section 6.7 “Load current adaptation (only with extra code TR/TO)”

Control type	Internal switches			Application
	S4	S5	S6	
$V^2$	1	0	0	- positive TC, - $R \approx \text{constant}$ - brightness controls

## 6 Settings

P	0	1	0	- temperature-dependent TC - free-running economy circuit
$I^2$	0	0	1	- negative TC

### 6.6 Actual (power) output



The factory setting is that the actual (power) signal output corresponds to the  $V^2$  signal at the output of the power unit, and is therefore proportional to the power in the load ( $R = \text{constant}$ ). With the extra code TR/TO it can be switched over to a P or  $I^2$  signal.

⇒ Section 6.3 “Summary of possible settings”

Actual (power) signal output	Internal switches		
	S7	S8	S9
$V^2$	1	0	0
P	0	1	0
$I^2$	0	0	1

#### Adjust output

The signal at the actual (power) output is a voltage in the range 0 – 10V (corresponding to 0 – 100% of the particular measurement range). The trimmer (8) “output adjust” can be used to adjust the range end value:

Action	Response
Turn trimmer fully clockwise (right) output adjust 	Measurement range 0 – 100 % corresponds to a signal 0 – 10V
Turn trimmer fully counter-clockwise (left) output adjust 	Measurement range 0 – 100 % corresponds to a signal 0 – 5V



With P or  $I^2$  control loops, a load current adaptation must be made for operating currents that are less than half the rated load current!

⇒ Section 6.7 “Load current adaptation (only with extra code TR/TO)”

## 6.7 Load current adaptation (only with extra code TR/T0)

With P or  $I^2$  control, switch S15 must be in position 0 if the operating current is less than half the rated current. This is to ensure proper measurement of the load current for the subsidiary control loop, the current limiting, and the over-current / low current detection.



The factory setting must not be altered on the 150A and 250A versions!  
(Reserved for service purposes: 1A test mode)

Load current adaptation	Internal switch S 15
$I_L < 0.5 \times I_{ThyN}$	0
$I_L > 0.5 \times I_{ThyN}$	1

■ factory setting

## 6.8 Select operating modes and load types

The internal switches S3, S10 – S13 and S20 are used to set the required mode of operation.

In both phase-angle and burst-firing modes the thyristor power unit basically operates with a subsidiary  $V^2$  control loop. With extra code T0 or TR this can be changed over from  $V^2$  to P or  $I^2$  control.

⇒ Section 6.5 “Subsidiary control loops”

Switch	S3	S10	S11	S12	S13	S14	S17	S18	S19
<b>Operating mode:</b>									
<b>Phase-angle control</b>									
■ for resistive or transformer load	1	1	0	0	0	1	1	1	
<b>Burst-firing operation</b>									
■ resistive load	0	1	0			1	1	1	
■ transformer load	0	0	1	1	1	1	1	1	2
- R ≈ constant				0	0				
- $\frac{R_w}{R_K} > 1$				1	1				
- fixed cycle (500ms)									2
- variable cycle									1

## 6 Settings

---

It is not possible to change over to phase-angle control if S12 and S13 are closed.

⇒ Section 2.3 “Burst-firing operation for transformer loads and loads with a high positive temperature coefficient TC (mixed operation)”

### 6.9 Economy circuit

Two single-phase units can be used at any time to implement an “economy circuit” in a 3-phase system.

The switch settings that are required for this, depending on the type of load and circuit, can be found in the table.



The thyristor power units must always be dimensioned for the phase-phase voltage, regardless of whether the load is wired in a star or delta configuration.

It is vital to ensure that the rotating electrical field is right-handed, i.e. clockwise rotation.

Terminal V must be linked to phase L2 on both power units.

⇒ Section 4.6 “Free-running economy circuit, purely resistive loads” and Section 4.7 “Master-slave economy circuit, with resistive/inductive loads”

## 6.9.1 Free-running economy circuit (asynchronous switching) for resistive loads

A free-running economy circuit has the advantage that the average loading of the supply network is reduced. Both power units operate independently and regulate the required 3-phase power quite precisely. Even a possible part-load failure will not necessarily have an effect on the temperature stability of the control loop.

A subsidiary P control loop is required for both power units.

Switch	S3	S4	S5	S6	S10	S11	S12	S13	S14	S17	S18	S20	S21
<b>Economy circuit</b> (free-running)													
■ resistive load	0	0	1	0	1	0	0	0	1	1	1	2	
(master-slave)													
■ resistive load													
- master function	0				1	0			1	1	1		1
- slave function	0				1	0			0	2	2		1
■ transformer load													
- master function	0				0	1	1	1	1	1	1	2	1
- slave function	0				0	1	1	1	0	2	2	2	1

If S12 and S13 are closed, it is not possible to change over to phase-angle control.

⇒ Section 2.3 “Burst-firing operation for transformer loads and loads with a high positive temperature coefficient TC (mixed operation)”

## 6.9.2 Master-slave economy circuit (synchronous switching) for resistive and transformer loads

In the standard version, the master-slave economy circuit operates with a  $V^2$  control. With extra code TO/TR it is also possible to use a P control and part-load regulation. The control electronics of the master unit takes on the actual power control function, and drives the slave unit in synchronization. This makes it possible to drive transformer loads.

The combination of the fixed cycle time of the  $V^2$  control and the delta load configuration makes it possible to achieve good voltage regulation for the individual load resistances, even in the event of a part-load failure.

⇒ Section 4.7 “Master-slave economy circuit, with resistive/inductive loads”



The jumpers on pin header X503 of the slave unit must be turned through 90° !

⇒ Section 6.2 “Adjustment switches S1 – 21 and pin headers X503 / X504”

# 6 Settings

## 6.10 Firing-pulse inhibit

Inhibiting the firing pulses is a simple way of switching high powers. In phase-angle control, the thyristor power unit commences with a soft start after firing-pulse inhibit has been used. In burst-firing operation with a transformer load, the power unit first starts up in phase-angle control and then switches over to burst-firing.



In order to be able to disconnect a system, a contactor or main switch must be fitted in the supply line circuit!

A contact can be wired between Terminals 6 and 7 to shut off the thyristors at the next zero-crossing point. This external contact can be a make contact or a break contact, depending on the position of S21.

⇒ Section 6.2 “Adjustment switches S1 – 21 and pin headers X503 / X504”



Only a make contact can be used as the external contact for a master-slave economy circuit.

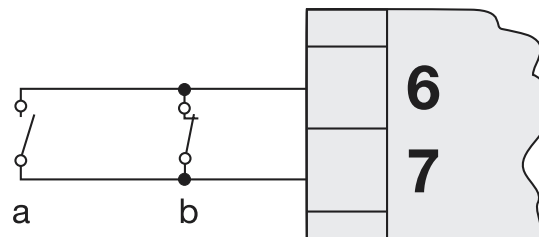

External contact	Internal switch S21	Response
make (a)	1	Load is continuously shut off while the external contact is closed.
break (b)	2	Load is continuously shut off while the external contact is open.

## 7 Technical data

### 7.1 Load circuit

Nominal load voltage	24V-20%/+15% AC 45 – 63Hz 42V-20%/+15% AC 45 – 63Hz 115V-20%/+15% AC 45 – 63Hz 230V-20%/+15% AC 45 – 63Hz 265V-20%/+15% AC 45 – 63Hz 400V-20%/+15% AC 45 – 63Hz 460V-20%/+15% AC 45 – 63Hz 500V-20%/+15% AC 45 – 63Hz (supply voltage for control electronics = nominal load voltage)
Continuous load current $I_L$	25A, 50A, 75A, 100A, 150A, 250A
Load types	resistive and resistive-inductive loads ( $B \leq 1.2$ Tesla)
Current limiting	With phase-angle control, the load current can be adjusted over the range 10 – 100% $I_N$ by a trimmer on the front panel. The limiting is based on the rms value of the load current.
Fusing	super-fast semiconductor fuse
TSE circuit	RC network as standard
Power loss	$\approx 1.3V \times I_L$ (A)
Control accuracy	Supply voltage fluctuations within the tolerance range (-20%/+15%) are accurately compensated. Fluctuations $\leq 0.5\%$ .

### 7.2 Control

Control signal	0 (4) – 20mA $R_I = 50 \Omega$ 0 (2) – 10V $R_I = 25k\Omega$ 0 (1) – 5V $R_I = 12k\Omega$ 0/10V (0/5V) $R_I = 12k\Omega$ 0/20mA $R_I = 50\Omega$ floating contact or manual control by an external 5 k $\Omega$ potentiometer
Input signal attenuation	adjustment range 100 – 20%

### 7.3 General data

Circuit variants	<ul style="list-style-type: none"> <li>- single-phase operation</li> <li>- star circuit with accessible star point</li> <li>- open delta circuit</li> <li>- economy circuit using master-slave principle and subsidiary <math>V^2</math> control in burst-firing operation</li> <li>- free-running economy circuit (star or delta) only with subsidiary P control in burst-firing operation</li> </ul>
Operating modes	<ul style="list-style-type: none"> <li>- phase-angle control for resistive and transformer loads, with soft start (with current limiting for extra codes TR, TO)</li> <li>- burst-firing operation for resistive or transformer load</li> </ul>
Features	Two single-phase units can be linked to form an economy circuit for burst-firing operation. <ul style="list-style-type: none"> <li>- free-running economy circuit for resistive loads</li> <li>- master-slave economy circuit for resistive and transformer loads</li> </ul>
Subsidiary control types	$V^2$ control as standard. With extra code TR or TO: free choice of $V^2$ , P, $I^2$ control via internal switches.

## 7 Technical data

Actual (power) output	V <sup>2</sup> signal as standard. With extra code TR or TO: free choice between V <sup>2</sup> , P, or I <sup>2</sup> signal via internal switches, adjustable from 0 – 5V to 0 – 10V. I <sub>max</sub> ≈ 2 mA.
Electrical connection	Control wiring by screw terminals for conductor cross-sections 0.2 – 2.5 mm <sup>2</sup> . Load connections by cable lugs to DIN 46 212.
Protection	IP00 as per EN 60 529, heatsink is grounded
Permitted ambient temperature range	0 – 45°C Permitted current derated by 2% for each °C increase in ambient temperature; the maximum permissible ambient temperature must not exceed 60°C.
Permitted storage temperature range	-10 to +70°C
Climatic conditions	rel. humidity ≤ 75% annual mean, no condensation
Cooling	natural convection
Operating position	vertical
Operating conditions	The thyristor power unit is designed as a built-in unit to: VDE 0160 5.5.1.3 (5/88) VDE 0106 Part 100 (3/83) pollution degree 2 to VDE 0110 Part 1 4.2 (1/89) overvoltage category Ü III to VDE 0160 5.7 (5/88)
Test voltage	to VDE 0160 Table 4 (6/88)
Electromagnetic compatibility	Control electronics to EN 61 326
Creepage distance	control electronics to load circuit ≥ 10mm control electronics to housing ≥ 10mm Unit can be connected to SELV circuits. SELV = Seperate Extra Low Voltage
Housing	TYA110/3, 25 (50) 110 x 195 x 152 mm TYA110/3, 75 (100) 125 x 195 x 170 mm TYA110/3, 150 (250) 150 x 220 x 280 mm
Weight	TYA110/3, 25 (50) 2.8 kg TYA110/3, 75 (100) 3.7 kg TYA110/3, 150 8.6 kg TYA110/3 250 9.0 kg
Standard accessories	1 mounting plate for wall-mounting 1 Operating Instructions B 70.9040

The thyristor power unit does not require any maintenance.  
In the event of a fault, the following points should be observed:

### 8.1 Fault-finding

If faults occur during commissioning, we recommend that you first check the positions of the internal switches.

⇒ Section 6.3 “Summary of possible settings”

If the fault persists, check the following items:

- Is the supply voltage present for the thyristor power unit?  
Check the phase sequence as well.
- Are all other connections also correct?
- Is the controller operating properly?  
Check the operation manually, by using an external potentiometer.

⇒ Section 6.4 “Control inputs”

### 8.2 Replacing the semiconductor fuse

If the red LED “fuse” lights up, this means that a semiconductor fuse has blown.

\* Disconnect the system from the supply voltage.

⇒ Section 6.1 “Opening the housing”

#### 8.2.1 Type TYA-110/3, 025 to 100, ...

Wrench 10 mm a/f

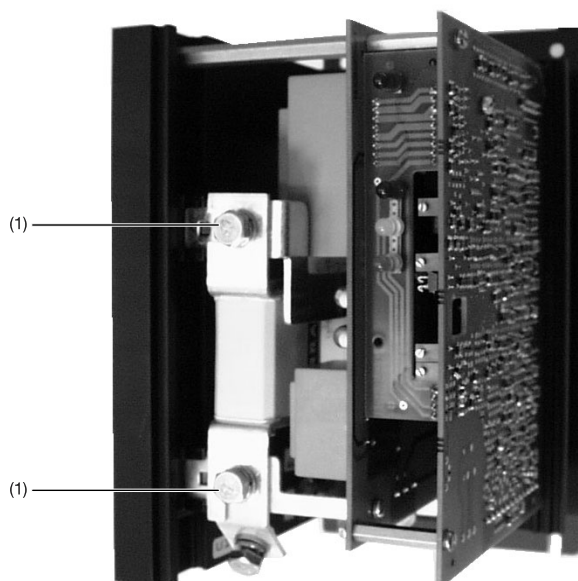

# 8 Faults

---

## 8.2.2 Type TYA-110/3, 150, ...

Wrench 13 mm a/f

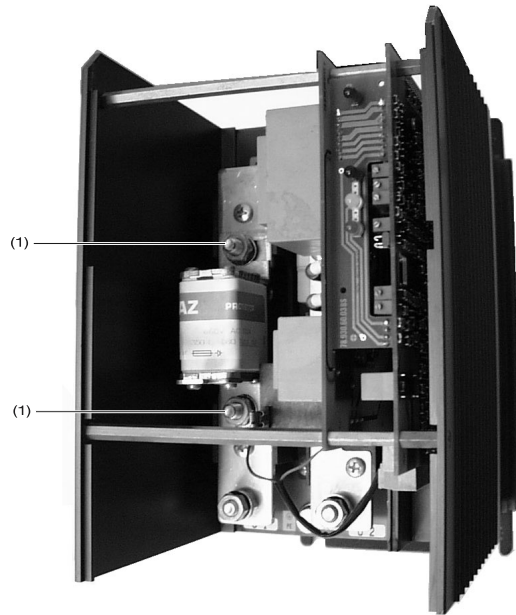

## 8.2.3 Type TYA-110/3, 250, ...

Wrench 13 mm a/f

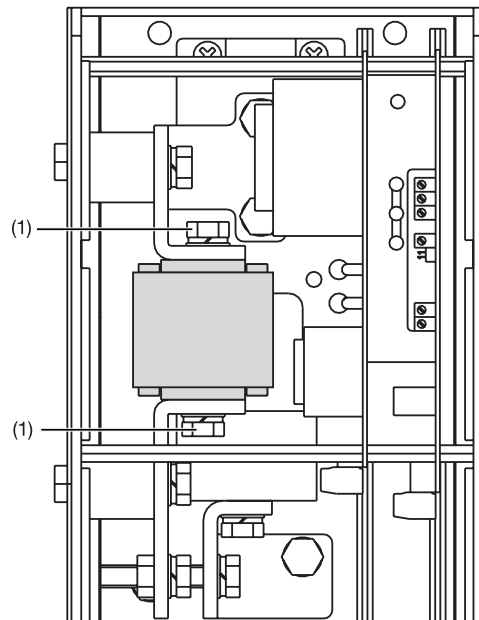

- \* Remove the two hexagonal head fixing screws (1) for the semiconductor fuse, and take out the fuse.
- \* Insert a new semiconductor fuse!

- \* Replace the fixing screws.

- \* Re-assemble the housing



Use only original replacement fuses. If other fuses are used, this will invalidate the warranty!

### Replacement fuses

⇒ Section 1.4.3 “Accessories”



The pcbs carry supply line voltages. Work on the circuitry must therefore only be carried out while the equipment is completely disconnected from the supply!

To avoid dangerous situations, follow the regulations for “Working on live equipment“ (VDE 0100 Part 410).



**JUMO GmbH & Co. KG**

Street address:  
Moltkestraße 13 - 31  
36039 Fulda, Germany  
Delivery address:  
Mackenrodtstraße 14  
36039 Fulda, Germany  
Postal address:  
36035 Fulda, Germany  
Phone: +49 661 6003-0  
Fax: +49 661 6003-607  
E-mail: [mail@jumo.net](mailto:mail@jumo.net)  
Internet: [www.jumo.net](http://www.jumo.net)

**JUMO Instrument Co. Ltd.**

JUMO House  
Temple Bank, Riverway  
Harlow, Essex CM20 2TT, UK  
Phone: +44 1279 635533  
Fax: +44 1279 635262  
E-mail: [sales@jumo.co.uk](mailto:sales@jumo.co.uk)  
Internet: [www.jumo.co.uk](http://www.jumo.co.uk)

**JUMO Process Control, Inc.**

8 Technology Boulevard  
Canastota, NY 13032, USA  
Phone: 315-697-JUMO  
1-800-554-JUMO  
Fax: 315-697-5867  
E-mail: [info@jumo.us](mailto:info@jumo.us)  
Internet: [www.jumo.us](http://www.jumo.us)