

JUMO LOGOSCREEN fd

Secure Data Management and FDA-Compliant Measured Data Recording



B 706585.4

Installation Instructions



Contents

1	Introduction	5
1.1	Preface	5
1.2	Arrangement of the documentation	6
1.3	Typographical conventions	9
2	Identifying the instrument version	11
2.1	Nameplate	11
2.2	Order details	12
2.3	Standard accessories	13
2.4	Accessories	13
3	Installation	15
3.1	Installation site and climatic conditions	15
3.2	Dimensions	15
3.3	Mounting in a panel	16
4	Electrical connection	17
4.1	Installation notes	17
4.2	Procedure	18
4.3	Overview of the electrical isolation	19
4.4	Connection diagram	20
4.5	Connection examples concerning binary inputs/outputs	26
5	Functional test	29
6	Technical data (extract from data sheet)	31
6.1	Analog inputs	31

Contents

6.2	Binary inputs/outputs (option)	34
6.3	Outputs	34
6.4	Interfaces	34
6.5	Screen	35
6.6	Electrical data	35
6.7	Environmental influences	36
6.8	Housing	36
6.9	Approvals/marks of conformity	36
7	Glossary	37

1.1 Preface



Please read these Operating Instructions before commissioning the instrument. Keep the manual in a place that is accessible to all users at all times.

Please assist us to improve this operating manual, where necessary.

Your comments will be appreciated.



If any difficulties should arise during commissioning, you are asked not to carry out any manipulations that could endanger your rights under the instrument warranty!

Please contact the nearest subsidiary or the head office in such a case.



When returning modules, assemblies or components, the regulations of EN 61340-5-1 and EN 61340-5-2 "Protection of electronic devices from electrostatic phenomena" must be observed. Use only the appropriate **ESD** packaging for transport.

Please note that we cannot accept any liability for damage caused by ESD.

ESD=electrostatic discharge

1 Introduction

1.2 Arrangement of the documentation

The documentation for this instrument is addressed to equipment manufacturers (OEMs) and users with appropriate technical expertise. It consists of the following parts:

Instrument documentation in printed form

B 706585.1 Operating Instructions

The operating instructions are an extract from the operating manual and cover the basic operation of the paperless recorder.

B 706585.4(.1) Installation Instructions

The installation instructions describe the installation of the recorder and the connection of the supply and signal cables. The instructions also contain a list of the technical data.

B 706585.4 Installation instructions for recorders with die-cast zinc front

B 706585.4.1 Installation instructions for recorders with stainless steel front

Instrument documentation in the form of PDF files

The “Instrument documentation in the form of PDF files” is on the CD that is included in the delivery.

B 706585.0 Operating Manual

It contains information about commissioning, operation, parameterization and configuration on the instrument.

B 706585.1 Operating Instructions

The operating instructions are an extract from the operating manual and cover the basic operation of the paperless recorder.

B 706585.2.0 Interface Description (serial interfaces)

This provides information on the communication (RS232/RS485) with supervisory systems.

Interface Description (Ethernet interface)

This provides information on the connection of a paperless recorder to a company-internal network. This description is integrated into B 706585.2.0.

B 706585.2.3 Interface Description (PROFIBUS-DP interface)

This provides information on the connection of a paperless recorder to a PROFIBUS-DP system.

B 706585.4(.1) Installation Instructions

The installation instructions describe the installation of the recorder and the connection of the supply and signal cables. The instructions also contain a list of the technical data.

B 706585.4 Installation instructions for recorders with die-cast zinc front

B 706585.4.1 Installation instructions for recorders with stainless steel front

B 706585.6 Setup Program

The manual describes the function of the setup program. The setup program is available as an option.

T 706585 Data Sheet

The data sheet contains general information, the order details and the technical data.

B 709701.0 PC Evaluation software PCA3000

The operating manual describes the operation and the features of the PC evaluation software.

PCA3000 serves to visualize and evaluate process data (measurement data, batch data, messages, instrument audit trails, ...). The process data can be read in via the CompactFlash memory card, or made available through the PCC software.

B 709702.0 PCA Communications software PCC

The operating manual describes the operation and the features of the PCA Communications software.

PCC is responsible for the data transfer from the recorder to a PC, or to a network.

B 709703.0 PC Security Manager Software PCS

The operating manual describes the operation and the features of the PC Security Manager software.

The PCS ensures that only authorized persons can gain access to the system components (instrument, PC software) and use electronic signatures on electronic documents.

The configuration of the Security Manager can only be performed by the system administrator.

1 Introduction

B 709704.0

PC Audit Trail Manager Software PCAT

The operating manual describes the operation and the features of the PC audit trail manager software.

PCAT documents actions performed in the PC software components, which lead to modifications of files, user lists (rights files), device lists etc. The different message types are: "Information", "Warnings" and "Errors".

Audit trail records cannot be modified.



Device audit trail data are not shown in PCAT, only in PCA3000.

Internet



All documents are available for downloading at www.jumo.net

1.3 Typographical conventions

Warning signs

The signs for **Danger** and **Caution** are used in this manual under the following conditions:



Danger

This symbol is used when there may be **danger to personnel** if the instructions are ignored or not followed correctly!



Caution

This symbol is used when there may be **damage to equipment or data** if the instructions are ignored or not followed correctly!



Caution

This symbol is used where special care is required when handling **components liable to damage through electrostatic discharge**.

Note signs



Note

This symbol is used when your **special attention** is drawn to a remark.



Reference

This symbol refers to **further information** in other manuals, chapters or sections.



Action instruction

This symbol indicates that an **action to be performed** is described.

The individual steps are marked by this asterisk, e.g.

* Rotate control knob

* Press control knob

1 Introduction

2 Identifying the instrument version

2.1 Nameplate

Position The nameplate is glued onto the paperless recorder.

Contents It contains important information, such as:

Description	Designation on the nameplate	Example
Device type	Typ	706585/18-321-33/020
Part no.	TN	00xxxxxx
Serial no.	F-Nr	0022969000013050006
Supply voltage		AC 110 – 240 V +10/-15 %, 48 – 63 Hz

Typ Please check the type supplied against your order document. Refer to Chapter 2.2 “Order details” for identification of the type.

TN The part no. provides an unambiguous definition of an article from the catalog. It is used in communication between the sales department and the customer.

F-Nr The serial number (F-Nr) indicates the production date (year/week). The figures concerned are in positions 12, 13, 14, 15.

Example:

F-Nr 00229690000**1305**0006

This shows that the paperless recorder was manufactured in 2013, week 5.

2 Identifying the instrument version

2.2 Order details

	(1) Basic type
706585	LOGOSCREEN fd
	(2) Basic type extension
0	No software package
1	With software package (setup program, PCA3000, PCC, PCS, PCAT, USB cable)
	(3) Language / Setup
8	Factory setting (German/English)
9	Set to customer specification
	(4) Module slot 1
0	Not used
2	3 analog inputs and 8 binary inputs/outputs
3	6 analog inputs
	(5) Module slot 2
0	Not used
2	3 analog inputs and 8 binary inputs/outputs
3	6 analog inputs
	(6) Module slot 3
0	Not used
1	6 relay outputs
2	3 analog inputs and 8 binary inputs/outputs
3	6 analog inputs
	(7) Voltage supply
25	AC/DC 20 to 30 V, 48 to 63 Hz
33	AC 100 to 240 V +10/-15 %, 48 to 63 Hz
	(8) Extra codes memory
020	Lithium battery for memory buffering (ex-factory)
021	Storage capacitor
	(9) Extra codes
.	Not used
260	Math and logic module
	(10) Extra codes housing
.	Not used
350	Universal carrying case TG-35 ^a
444	Stainless steel front with touchpad 
	(11) Extra codes
.	Without extra codes
267	PROFIBUS-DP interface

^a This extra code is available in combination with voltage supply AC 100 to 240 V, not with low supply voltage. UL and ATEX approvals not applicable. The protection type in the carrying case corresponds to IP20, outside IP20D.

Order code (1) (2) (3) (4) (5) (6) (7) (8) (9) (10) (11)
Order example 706585 / - - / , , ,

List extra codes in sequence, separated by commas.

2 Identifying the instrument version

2.3 Standard accessories

- 1 Installation Instructions B 706585.4
- 1 Operating Instructions B 706585.1
- 4 mounting brackets
- 1 panel seal
- 1 CD with detailed operating instructions and supplementary documentation (see Chapter 1.2 “Arrangement of the documentation”)

2.4 Accessories

- Software package (setup program, PCA3000, PCC, PCS, PCAT)
- CompactFlash memory cards
- USB memory sticks
- USB cable

2 Identifying the instrument version

3.1 Installation site and climatic conditions

The installation site should be as free as possible from vibration. Electromagnetic fields, such as those caused by motors, transformers, frequency converter etc. should be avoided as far as possible.

The ambient temperature at the site can be 0 to 50 °C, at a relative humidity of $\leq 75\%$, no condensation.

⇒ Chapter 4.1 “Installation notes”

3.2 Dimensions

Recorder with
zinc diecast
front

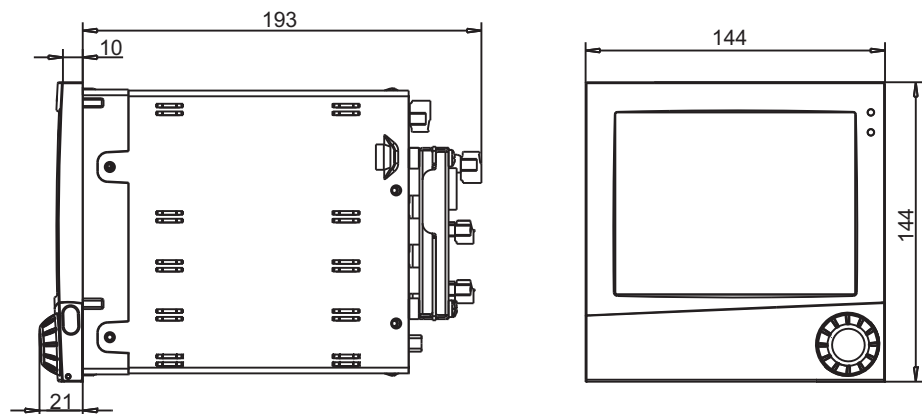

Panel cut-out

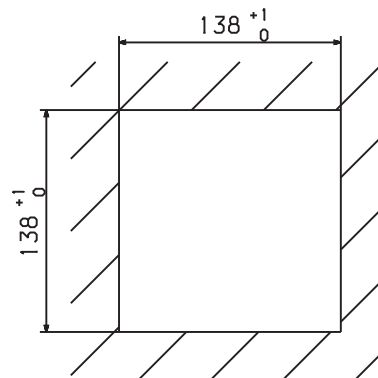

3 Installation

3.3 Mounting in a panel

- * Fit panel seal (IP65 seal).

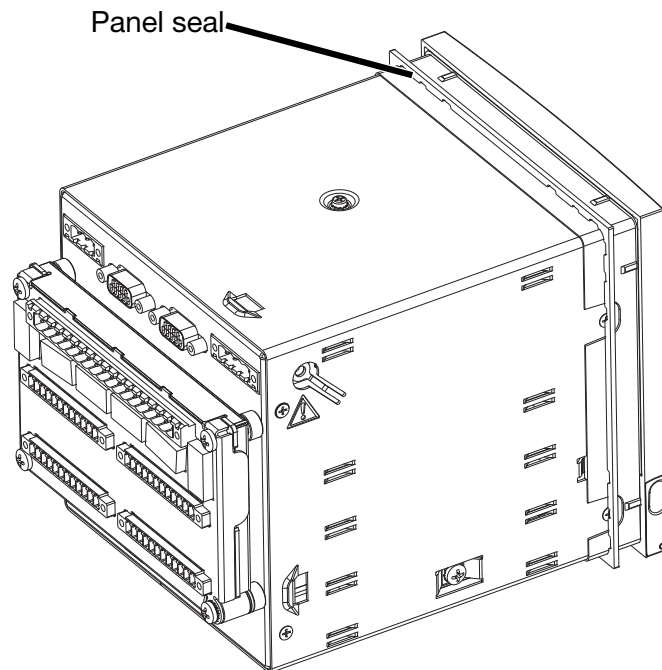

- * Insert the paperless recorder from the front into the panel cut-out.
- * From behind the panel, hook the four mounting brackets into the grooves on the sides of the housing and tighten them evenly up against the back of the panel.

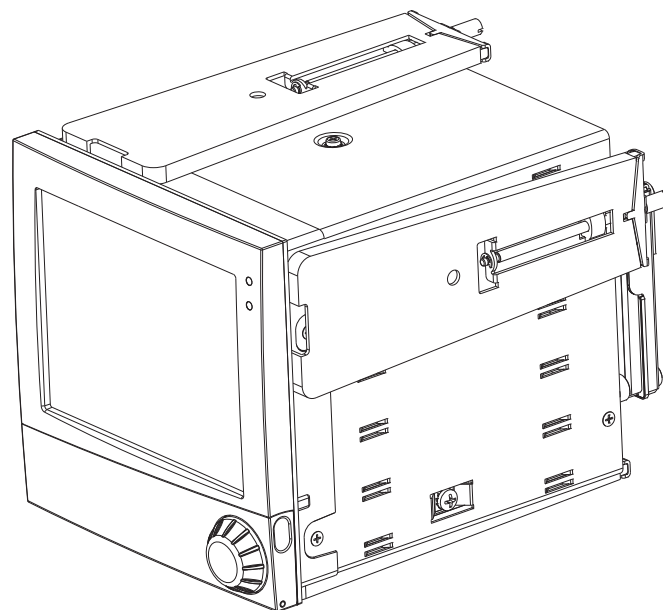

4.1 Installation notes

- The device is designed for installation in electrical cabinets, machines, or systems. External fuse protection and shut-off must be provided for the device. The fuse must not exceed 20 A.

An instrument fuse is already built into the device itself (depending on the device design).

AC/DC 20 — 30 V, 48 — 63 Hz: fuse 2.5 A slow-blow

AC 100 — 240 V +10/-15 %, 48 — 63 Hz: fuse 1.25 A slow-blow

- The choice of cable, the installation and the electrical connection must conform to the requirements of VDE 0100 “Regulations on the Installation of Power Circuits with Nominal Voltages below 1000 V” or the appropriate local regulations.
- Work inside the instrument must only be carried out to the extent described and, like the electrical connection, only by qualified personnel.
- For service and repair work the device must be disconnected from the power supply (all poles).
- To generate the operating voltage of 20 ... 30 V for Extra Low Voltage (ELV), the maximum nominal voltage of an external power supply must not exceed 240 V (line-to-line and line-to-neutral). If the external nominal voltage is greater than 240 V, an Safety Extra Low Voltage (SELV) power supply must be used. For line-to-line supply of the external power supply, the power supply must have all-pole fuse protection. The fuse must shut off both connections.
- Run input, output and supply cables separately and not parallel to one another.
- In EMC disturbed environments, all input and output cables without connection to the mains supply must be arranged as twisted and screened cables. Earth the screen on the instrument side to the earth potential.
- Ground the instrument at the PE terminal of the supply voltage connector to the protective earth conductor. This cable must have the same cross-section as that used for the supply cables. Earthing cables must be wired in a star configuration to a common earth point that is connected to the protective earth conductor of the electrical supply.
- Do not connect any additional loads to the supply terminals of the instrument.
- The device is not suitable for use in areas with an explosion hazard (**Ex** areas).
- Electromagnetic compatibility (EMC) conforms to the standards and regulations cited in the technical data.
⇒ Chapter 6 “Technical data (extract from data sheet)”
- Inductive loads close to the instrument, such as contactors or solenoid valves, should have RC modules fitted for interference suppression.

4 Electrical connection

4.2 Procedure

- * Make the electrical connection as per Chapter 4.4 “Connection diagram”.
- * Apply strain relief for the connecting cables, if necessary.

Instrument variant 1

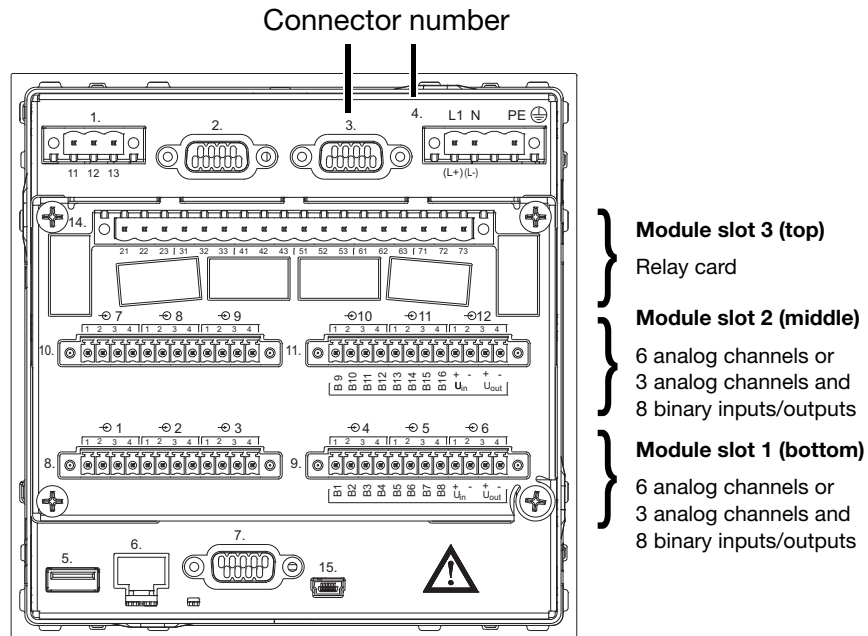

Instrument variant 2

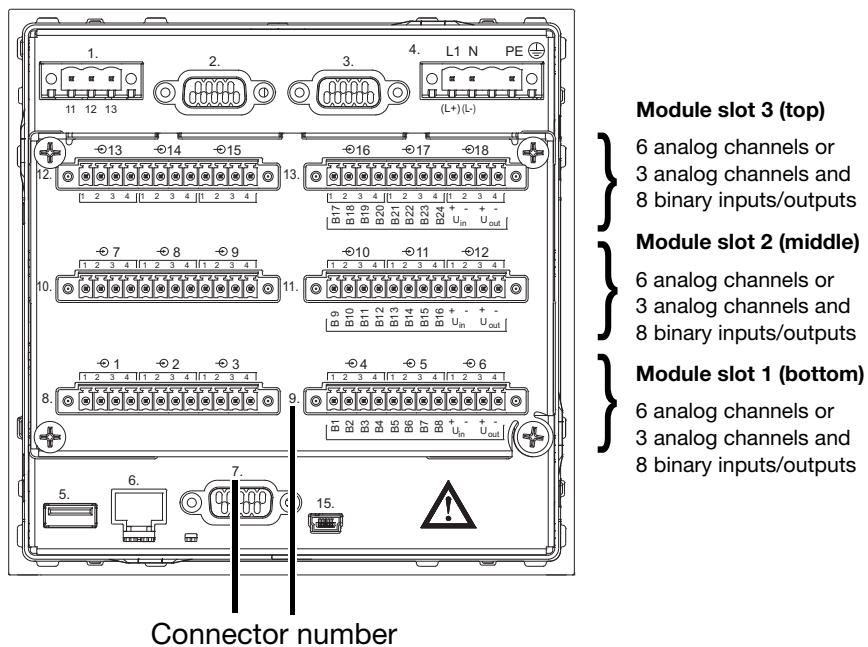

4 Electrical connection

Connector summary

Connector/slot	Function
1	Relay output
2	RS232 for barcode reader
3	PROFIBUS-DP
4	Supply voltage
5	USB host interface
6	Ethernet
7	RS232 and RS485
8	Analog input
9	Analog input or binary inputs/outputs
10	Analog input
11	Analog input or binary inputs/outputs
12	Analog input
13	Analog input or binary inputs/outputs
14	Relay card (for instrument variant 1)
15	USB device interface

4.3 Overview of the electrical isolation

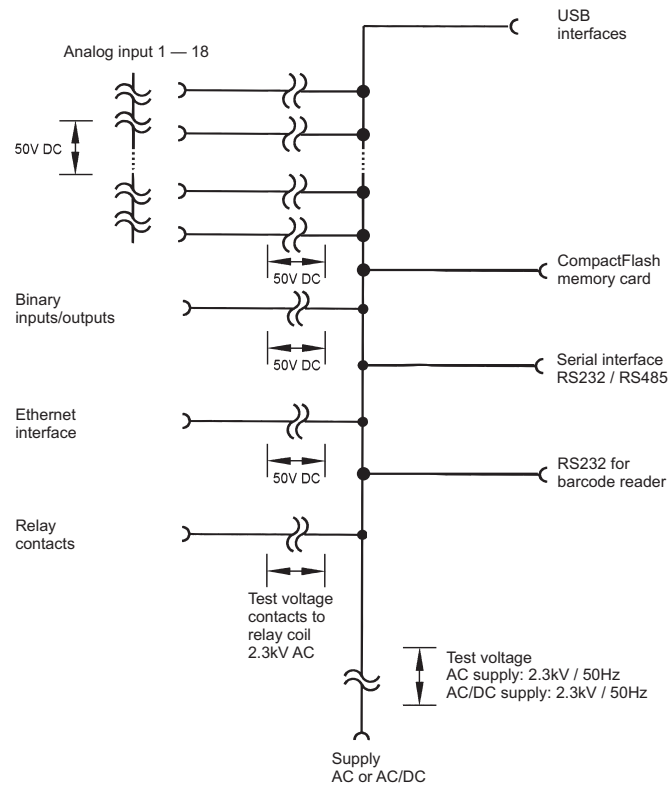

4 Electrical connection

4.4 Connection diagram



The electrical connection must only be carried out by specialist personnel.

Back panel ⇒ Chapter 4.2 “Procedure”

Connections

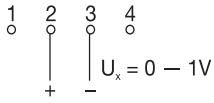
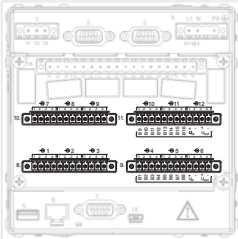
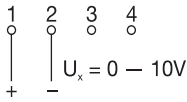
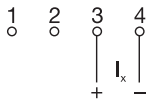
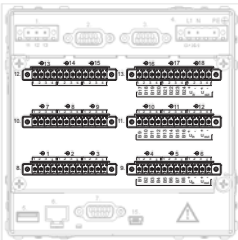

	Terminal assignment	Connector	Diagram
Supply voltage	Supply voltage as on nameplate	Connector 4 L1 (L+) N (L-) PE	
Analog inputs	Thermocouple	Connectors 8 to 11 (input 1 – 12) for instrument variant 1 or connectors 8 to 13 (input 1 – 18) for instrument variant 2 	
	RTD temperature probe 2-wire circuit		
	RTD temperature probe 3-wire circuit		
	RTD temperature probe 4-wire circuit		
	Resistance transmitter E = end S = slider A = start		
	Potentiometer in 2-wire circuit		
	Potentiometer in 3-wire circuit		
	Potentiometer in 4-wire circuit		

4 Electrical connection

	Terminal assignment	Connector	Diagram
Analog inputs	Voltage input 0 – 1 V	Connectors 8 to 11 (input 1 – 12) for instrument variant 1	
	Voltage input 0 – 10 V		
	Current input		
		<p>or</p> <p>connectors 8 to 13 (input 1 – 18) for instrument variant 2</p> 	



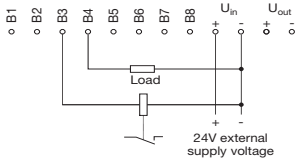
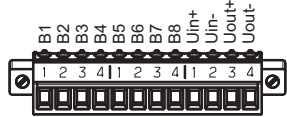
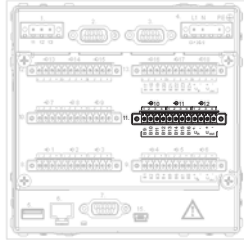
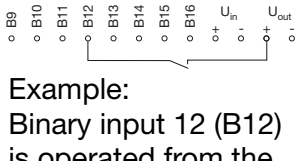
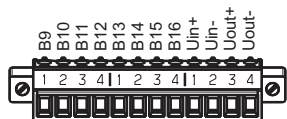

4 Electrical connection

Binary inputs/ outputs



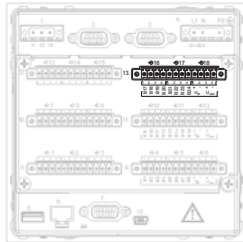

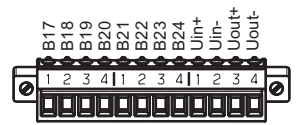

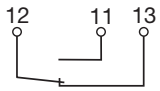
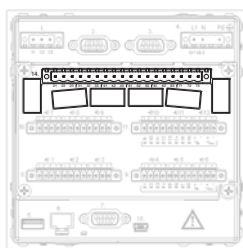
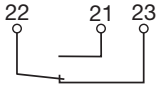
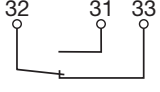
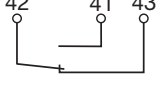
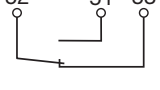
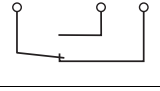
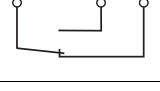
Terminal assignment	Connector	Diagram
 <p>The configuration in the instrument or in the setup program defines whether it is a binary input or binary output.</p>		
<p>B1 ... B8</p> <p>voltage-controlled LOW = -3 to +5 V DC HIGH = 12 to 30 V DC</p> <p>B1 Binary input/output 1 B2 Binary input/output 2 B3 Binary input/output 3 B4 Binary input/output 4 B5 Binary input/output 5 B6 Binary input/output 6 B7 Binary input/output 7 B8 Binary input/output 8</p> <p>U_{in+} external supply voltage U_{in-} ground U_{out+} +24 V (60 mA) internal supply voltage U_{out-} ground</p>	<p>Connector 9</p> <p>only for modules with 3 analog inputs</p> 	 <p>Example: Connecting a load to binary output 4 (B4) and a solid-state relay to binary output 3 (B3) requires an external supply voltage.</p> <p>Diagram of the connector:</p> 
<p>B9 ... B16</p> <p>voltage-controlled LOW = -3 to +5 V DC HIGH = 12 to 30 V DC</p> <p>B9 Binary input/output 9 B10 Binary input/output 10 B11 Binary input/output 11 B12 Binary input/output 12 B13 Binary input/output 13 B14 Binary input/output 14 B15 Binary input/output 15 B16 Binary input/output 16</p> <p>U_{in+} external supply voltage U_{in-} ground U_{out+} +24 V (60 mA) internal supply voltage U_{out-} ground</p>	<p>Connector 11</p> <p>only for modules with 3 analog inputs</p> 	 <p>Example: Binary input 12 (B12) is operated from the internal supply voltage.</p> <p>Diagram of the connector:</p> 

4 Electrical connection

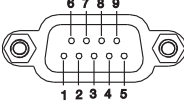

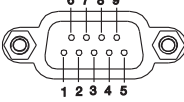
Binary inputs/ outputs

Terminal assignment	Connector	Diagram
<p>B17 ... B24</p> <p>voltage-controlled LOW = -3 to +5 V DC HIGH = 12 to 30 V DC</p> <p>B17 Binary input/output 17 B18 Binary input/output 18 B19 Binary input/output 19 B20 Binary input/output 20 B21 Binary input/output 21 B22 Binary input/output 22 B23 Binary input/output 23 B24 Binary input/output 24</p> <p>U_{in+} external supply voltage U_{in-} ground U_{out+} +24 V (60 mA) internal supply voltage U_{out-} ground</p>	<p>Connector 13</p> <p>only for instrument variant 2 and on modules with 3 analog inputs</p> 	 <p>Example: Binary input 20 (B20) is operated from the internal supply voltage.</p> <p>Diagram of the connector:</p> 
<h3>Relay outputs</h3> <p>Relay 1 - alarm changeover (SPDT)</p>	<p>Connector 1</p> 	
<p>Relay 2 changeover (SPDT)</p>	<p>Connector 14</p> <p>only for instrument variant 1</p> 	
<p>Relay 3 changeover (SPDT)</p>		
<p>Relay 4 changeover (SPDT)</p>		
<p>Relay 5 changeover (SPDT)</p>		
<p>Relay 6 changeover (SPDT)</p>		
<p>Relay 7 changeover (SPDT)</p>		

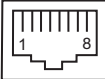
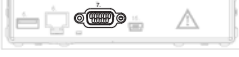
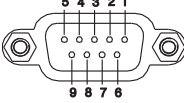
4 Electrical connection

Terminal assignment	Connector	Diagram
Interfaces RS232C for barcode reader 9-pin SUB-D socket connector 2 RxD receive data 3 TxD transmit data 5 GND ground	Connector 2 	
PROFIBUS-DP 9-pin SUB-D socket connector (extra code) 3 RxD/TxD-P B conductor Receive/transmit data positive 5 DGND Data transmission ground 6 VP supply voltage positive 8 RxD/TxD-N A conductor Receive/transmit data negative	Connector 3 	
USB host interface for memory sticks The recorder without stainless steel front also has a USB host interface on the front panel, connected in parallel. The two interfaces cannot both be operated at the same time.	Connector 5 	
Ethernet RJ45 socket connector 1 TX+ transmit data + 2 TX- transmit data - 3 RX+ receive data + 6 RX+ receive data -	Connector 6 	
RS232C 9-pin SUB-D socket connector (switchable to RS485) 2 RxD receive data 3 TxD transmit data 5 GND ground	Connector 7 	

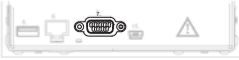
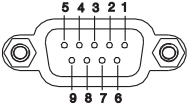
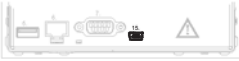
4 Electrical connection

Terminal assignment	Connector	Diagram
<p>RS485 9-pin SUB-D socket connector (switchable to RS232)</p> <p>3 TxD+/RxD+ Transmit/receive data +</p> <p>5 GND ground</p> <p>8 TxD-/RxD- Transmit/receive data -</p>	<p>Connector 7</p> 	
<p>USB device interface for connecting a PC</p> <p>The recorder without stainless steel front also has a USB device interface on the front panel, connected in parallel. The two interfaces cannot both be operated at the same time.</p>	<p>Connector 15</p> 	

4 Electrical connection

4.5 Connection examples concerning binary inputs/outputs

Binary inputs Triggering via external relays and external supply voltage:

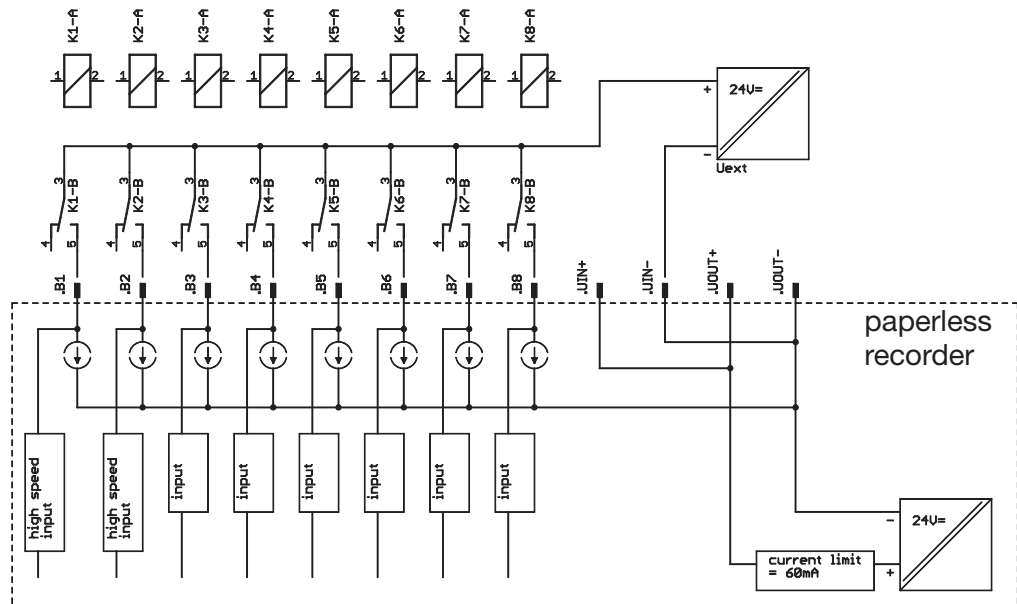

Triggering via external relays and internal supply voltage:

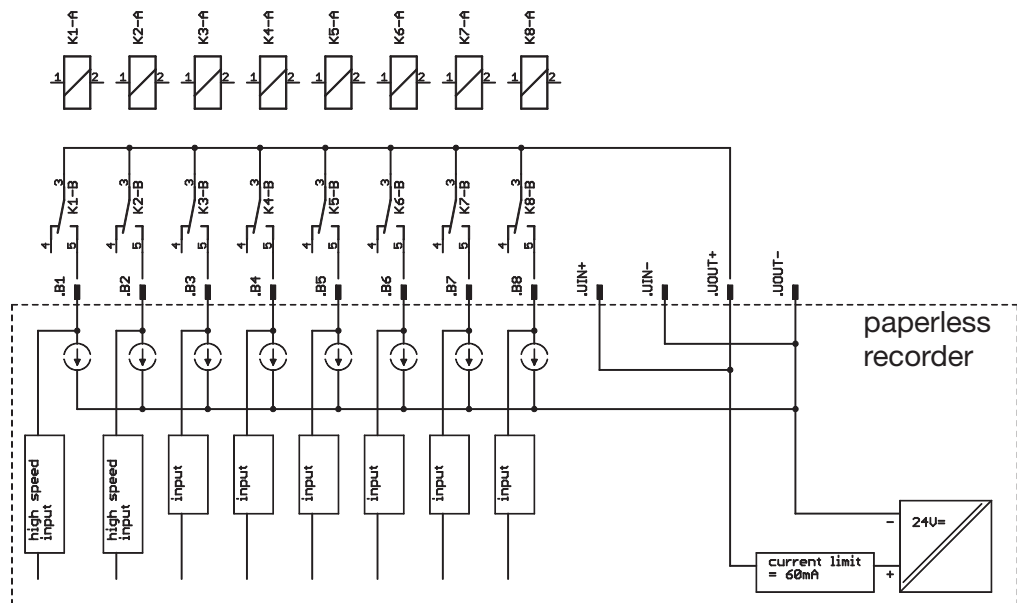

4 Electrical connection

Triggering via external opto-coupler and internal supply voltage:

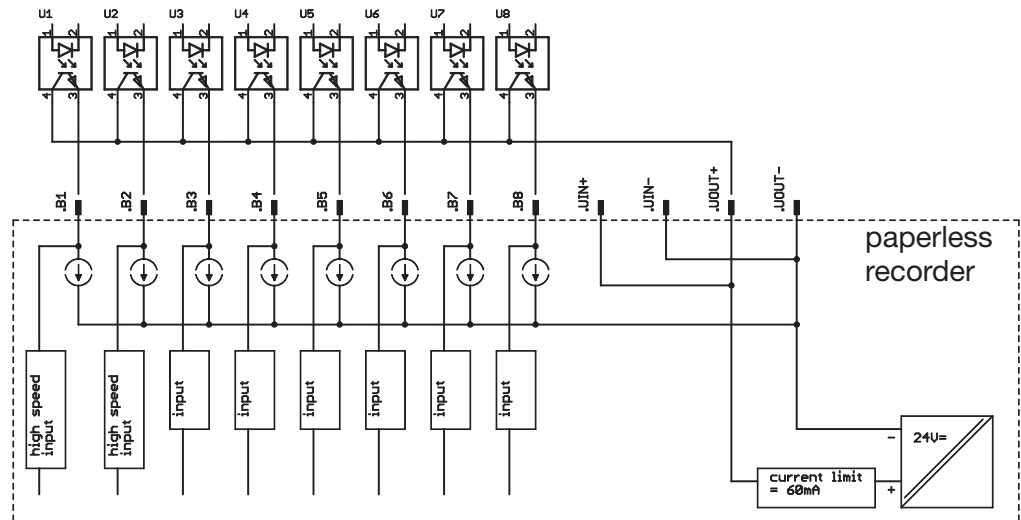

Triggering via external switches (potential-free) and internal supply voltage:

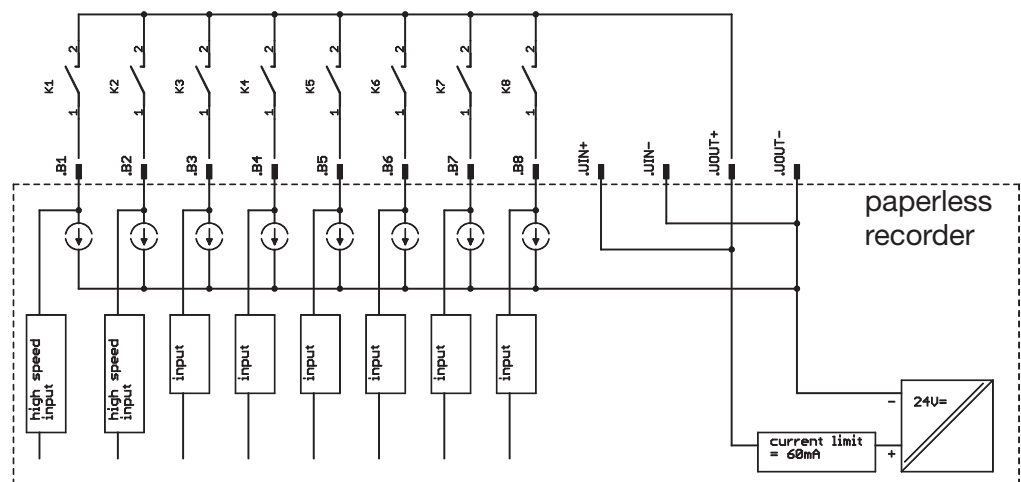

4 Electrical connection

Binary outputs

Triggering of external relays via external supply voltage:

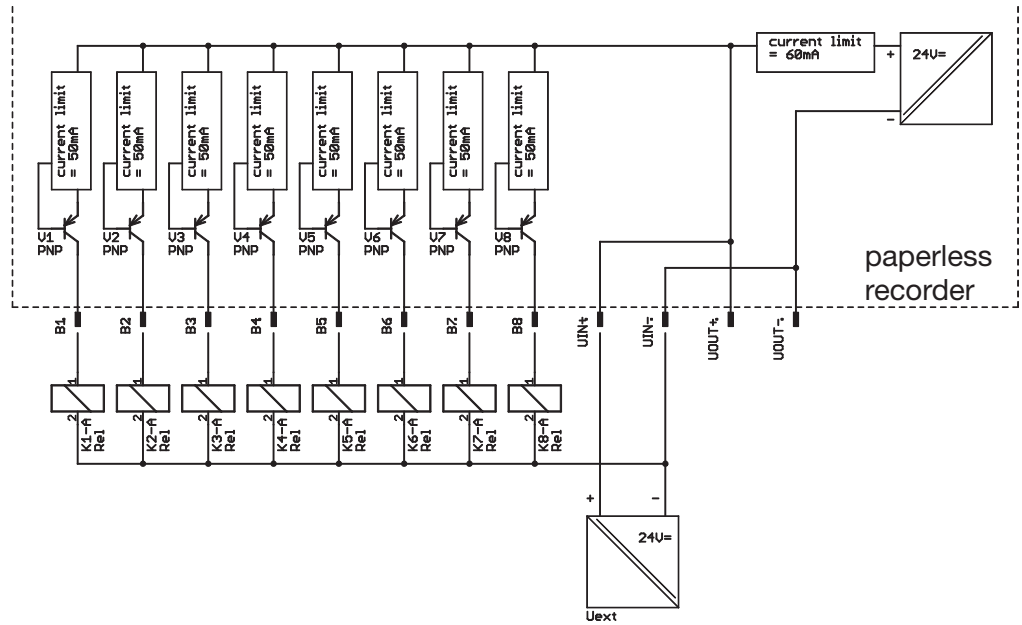

Triggering of external relays via internal supply voltage:

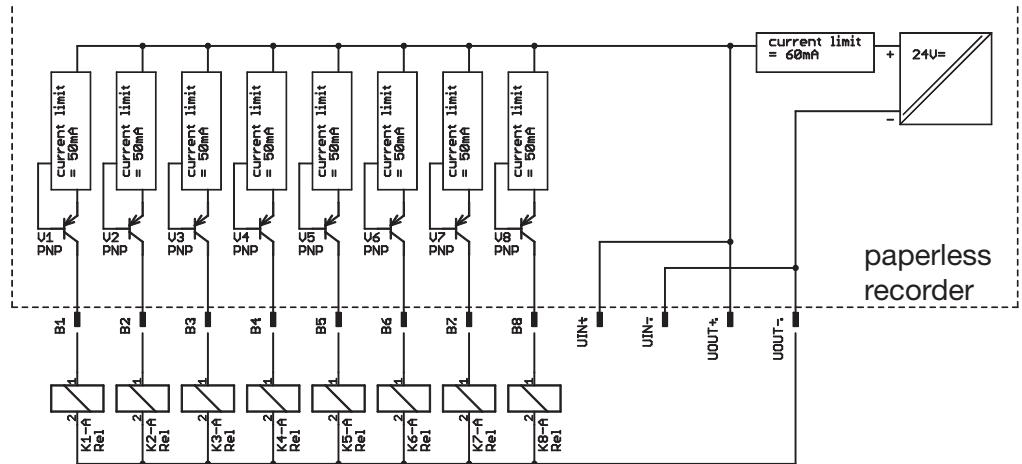

By triggering the external relays via the internal supply voltage the total current must not exceed 60 mA.

5 Functional test

After the paperless recorder has been installed and wired up, it can be commissioned. After applying or switching on the supply voltage, the start-up screen will appear for a short time.

Start-up screen



The visualization will start automatically after the initialization phase.

Visualization

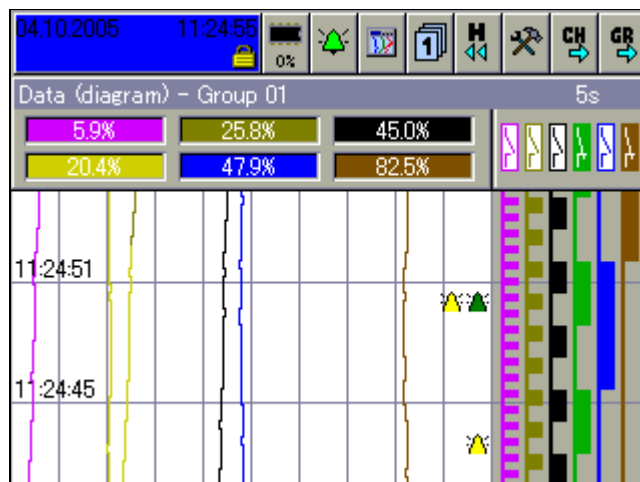

The paperless recorder is now in the recording phase.

Further steps



The recorder can be configured by an authorized person, either by using the control knob (rotating and pressing) or with the help of the PC setup program.

Further information about configuration can be found in the Operating Manual B 706585.0.

Finally, make another check that the connection, configuration and function of the recorder are all correct.

5 Functional test

6 Technical data (extract from data sheet)

6.1 Analog inputs

Thermocouple

Designation	Measuring range	Accuracy ^a
Fe-CuNi L DIN 43710	-200 to +900 °C	±0.1 %
Fe-CuNi J EN 60584	-200 to +1200 °C	±0.1 % from -100 °C
Cu-CuNi U DIN 43710	-200 to +600 °C	±0.1 % from -150 °C
Cu-CuNi T EN 60584	-270 to +400 °C	±0.1 % from -150 °C
NiCr-Ni K EN 60584	-200 to +1372 °C	±0.1 % from -80 °C
NiCr-CuNi E EN 60584	-200 to +1000 °C	±0.1 % from -80 °C
NiCrSi-NiSi N EN 60584	-100 to +1300 °C	±0.1 % from -80 °C
Pt10Rh-Pt S EN 60584	0 to 1768 °C	±0.15 %
Pt13Rh-Pt R EN 60584	0 to 1768 °C	±0.15 %
Pt30Rh-Pt6Rh B EN 60584	0 to 1820 °C	±0.15 % from 400 °C
W3Re/W25Re D	0 to 2495 °C	±0.15 % from 500 °C
W5Re/W26Re C	0 to 2320 °C	±0.15 % from 500 °C
W3Re/W26Re	0 to 2400 °C	±0.15 % from 500 °C
Chromel-copel GOST R 8.585-2001	-200 to +800 °C	±0.15 % from -80 °C
Chromel-alumel GOST R 8.585-2001	-200 to +1372 °C	±0.1 % from -80 °C
PLII (Platinel II)	0 to 1395 °C	±0.15 %
Shortest span	Type L, J, U, T, K, E, N, chromel-alumel, PLII: 100 °C Type S, R, B, D, C, W3Re/W26Re, chromel-copel: 500 °C	
Range start/end	freely programmable within the limits, in 0.1 °C steps	
Cold junction	Pt100 internal or thermostat external constant	
Cold junction accuracy (internal)	±1 °C	
Cold junction temperature (external)	-50 to +150 °C adjustable	
Sampling cycle	Channel 1 to 18: 125 ms in total	
Input filter	2nd order digital filter; filter constant adjustable from 0 to 10.0 sec	
Electrical isolation	see "Electrical data" on page 35 and "Overview of the electrical isolation" on page 19	
Resolution	> 14 bit	
Features	also programmable in °F	

^a The linearization accuracy refers to the maximum measuring range. The linearization accuracy is reduced with short spans.

RTD temperature probe

Designation	Connection circuit	Measuring range	Accuracy ^a	Measurement current
Pt100 EN 60751 (TC = $3.85 \cdot 10^{-3} \text{ 1/}^\circ\text{C}$)	2-/3-wire	-200 to +100 °C	±0.5 °C	≈ 250 μA
	2-/3-wire	-200 to +850 °C	±0.8 °C	≈ 250 μA
	4-wire	-200 to +850 °C	±0.5 °C	≈ 250 μA
Pt100 JIS 1604 (TC = $3.917 \cdot 10^{-3} \text{ 1/}^\circ\text{C}$)	2-/3-wire	-200 to +100 °C	±0.5 °C	≈ 250 μA
	2-/3-wire	-200 to +650 °C	±0.8 °C	≈ 250 μA
	4-wire	-200 to +650 °C	±0.5 °C	≈ 250 μA
Pt100 GOST 6651-94 A.1 (TC = $3.91 \cdot 10^{-3} \text{ 1/}^\circ\text{C}$)	2-/3-wire, 4-wire	-200 to +100 °C	±0.5 °C	≈ 250 μA
	2-/3-wire, 4-wire	-200 to +850 °C	±0.8 °C	≈ 250 μA
Pt500 EN 60751 (TC = $3.85 \cdot 10^{-3} \text{ 1/}^\circ\text{C}$)	2-/3-wire, 4-wire	-200 to +100 °C	±0.5 °C	≈ 100 μA
	2-/3-wire, 4-wire	-200 to +850 °C	±0.9 °C	≈ 100 μA
Pt1000 EN 60751 (TC = $3.85 \cdot 10^{-3} \text{ 1/}^\circ\text{C}$)	2-/3-wire	-200 to +100 °C	±0.5 °C	≈ 100 μA
	2-/3-wire	-200 to +850 °C	±0.8 °C	≈ 100 μA
	4-wire	-200 to +850 °C	±0.5 °C	≈ 100 μA

6 Technical data (extract from data sheet)

Designation	Connection circuit	Measuring range	Accuracy ^a	Measurement current
Ni100 DIN 43760 (TC = $6.18 \cdot 10^{-3} \text{ 1/}^\circ\text{C}$)	2-/3-wire, 4-wire	-60 to +180 °C	±0.4 °C	≈ 250 μA
Pt50 ST RGW 1057 1985 (TC = $3.91 \cdot 10^{-3} \text{ 1/}^\circ\text{C}$)	2-/3-wire	-200 to +100 °C	±0.5 °C	≈ 250 μA
	2-/3-wire	-200 to +1100 °C	±0.9 °C	≈ 250 μA
	4-wire	-200 to +100 °C	±0.5 °C	≈ 250 μA
	4-wire	-200 to +1100 °C	±0.6 °C	≈ 250 μA
Cu50 (TC = $4.26 \cdot 10^{-3} \text{ 1/}^\circ\text{C}$)	2-/3-wire	-50 to +100 °C	±0.5 °C	≈ 250 μA
	2-/3-wire	-50 to +200 °C	±0.9 °C	≈ 250 μA
	4-wire	-50 to +100 °C	±0.5 °C	≈ 250 μA
	4-wire	-50 to +200 °C	±0.7 °C	≈ 250 μA
Cu100 GOST 6651-94 A.4 (TC = $4.26 \cdot 10^{-3} \text{ 1/}^\circ\text{C}$)	2-/3-wire	-50 to +100 °C	±0.5 °C	≈ 250 μA
	2-/3-wire	-50 to +200 °C	±0.9 °C	≈ 250 μA
	4-wire	-50 to +100 °C	±0.5 °C	≈ 250 μA
	4-wire	-50 to +200 °C	±0.6 °C	≈ 250 μA
Connection circuit	2-, 3-, or 4-wire circuit			
Shortest span	15 °C			
Sensor lead resistance	max. 30 per conductor for 3-wire/4-wire circuit max. 10 per conductor for 2-wire circuit			
Range start/end	freely programmable within the limits, in 0.1 °C steps			
Sampling cycle	Channel 1 to 18: 125 ms in total			
Input filter	2nd order digital filter; filter constant adjustable from 0 to 10 sec			
Electrical isolation	see "Electrical data" on page 35 and "Overview of the electrical isolation" on page 19			
Resolution	> 14 bit			
Features	also programmable in °F			

^a The linearization accuracy refers to the maximum measuring range. The linearization accuracy is reduced with short spans.

Resistance transmitter and potentiometer

Designation	Measuring range	Accuracy ^a	Measurement current
Resistance transmitter	up to 4000 Ω	±4 Ω	≈ 100 μA
Potentiometer	< 400 Ω	±400 mΩ	≈ 250 μA
	≥ 400 Ω to 4000 Ω	±4 Ω	≈ 100 μA
Connection circuit	resistance transmitter: 3-wire circuit potentiometer: 2-/3-/4-wire circuit		
Shortest span	60Ω		
Sensor lead resistance	max. 30 per conductor for 4-wire circuit max. 10 per conductor for 2-/3-wire circuit		
Resistance values	freely programmable within the limits, in 0.1 steps		
Sampling cycle	Channel 1 to 18: 125 ms in total		
Input filter	2nd order digital filter; filter constant adjustable from 0 to 10.0 sec		
Electrical isolation	see "Electrical data" on page 35 and "Overview of the electrical isolation" on page 19		
Resolution	> 14 bit		

^a The linearization accuracy refers to the maximum measuring range. The linearization accuracy is reduced with short spans.

6 Technical data (extract from data sheet)

Input for DC voltage, DC current

Basic range	Accuracy ^a	Input resistance
-12 to +112 mV	$\pm 100 \mu\text{V}$	$R_E \geq 1 \text{ M}\Omega$
-10 to +210 mV	$\pm 240 \mu\text{V}$	$R_E \geq 470 \text{ k}\Omega$
-1.5 to +11.5 V	$\pm 6 \text{ mV}$	$R_E \geq 470 \text{ k}\Omega$
-0.12 to +1.12 V	$\pm 1 \text{ mV}$	$R_E \geq 470 \text{ k}\Omega$
-1.2 to +1.2 V	$\pm 2 \text{ mV}$	$R_E \geq 470 \text{ k}\Omega$
-11.2 to +11.2 V	$\pm 12 \text{ mV}$	$R_E \geq 470 \text{ k}\Omega$
Shortest span	5 mV	
Range start/end	freely programmable within the limits in 0.01 mV steps	
-1.3 to +22 mA	$\pm 20 \mu\text{A}$	burden voltage $\leq 3 \text{ V}$
-22 to +22 mA	$\pm 44 \mu\text{A}$	burden voltage $\leq 3 \text{ V}$
Shortest span	0.5 mA	
Range start/end	freely programmable within the limits in 0.01 mA steps	
Overrange/underrange	according to NAMUR NE 43	
Sampling cycle	Channel 1 to 18: 125 ms in total	
Input filter	2nd order digital filter; filter constant adjustable from 0 to 10.0 sec	
Electrical isolation	see "Electrical data" on page 35 and "Overview of the electrical isolation" on page 19	
Resolution	>14 bit	

^a The linearization accuracy refers to the maximum measuring range. The linearization accuracy is reduced with short spans.

Transducer short circuit/break

	Short-circuit ^a	Break ^a
Thermocouple	not detected	detected
RTD temperature probe	detected	detected
Resistance transmitter	not detected	detected
Potentiometer	not detected	detected
Voltage $\leq \pm 210 \text{ mV}$	not detected	detected
Voltage $> \pm 210 \text{ mV}$	not detected	not detected
Current	not detected	not detected

^a Programmable reaction of device, e.g. triggering alarm

6 Technical data (extract from data sheet)

6.2 Binary inputs/outputs (option)

Input or output	configurable as input or output
Number	8, 16 or 24, depending on the device version, to DIN VDE 0411, Part 500; max. 25 Hz, max. 32 V
Input <ul style="list-style-type: none"> level counting frequency 	<p>logic "0": -3 to +5 V (input current max. ± 1 mA), logic "1": 12 to 30 V ($2.5 \text{ mA} \leq \text{input current} \leq 5 \text{ mA}$)</p> <p>8Hz</p>
High-speed input <ul style="list-style-type: none"> task counting frequency 	<p>the first two binary inputs of each module (B1, B2, B9, B10, B17, B18), if the module is not fitted with relays or 6 analog inputs</p> <p>count function, e.g. for flow measurement</p> <p>10 kHz</p>
Output <ul style="list-style-type: none"> type level sampling cycle 	<p>open-collector output, switches relative to positive voltage</p> <p>logic "0": transistor is inhibited (max. permissible voltage across switching transistor 30 V, max. leakage current 0.1 mA)</p> <p>logic "1": transistor is switched on (max. voltage across switching transistor 1.6 V, max. current 50 mA)</p> <p>at least 1 sec (1 Hz)</p>

6.3 Outputs

1 relay (ex-factory)	changeover (SPDT), 3 A, 230 V AC ^a
6 relays (option)	changeover (SPDT), 3 A, 230 V AC ^{a, b}

^a With resistive load.

^b It is not permissible to mix SELV circuits and supply circuits.

6.4 Interfaces

RS232/RS485 (connector 7) <ul style="list-style-type: none"> protocol baud rate modem connector external inputs 	<p>Qty. 1, switchable between RS232 and RS485</p> <p>Modbus master, Modbus slave and barcode reader</p> <p>9600, 19200, 38400</p> <p>can be connected</p> <p>SUB-D</p> <p>via the Modbus master/slave function, 24 analog and 24 binary</p>
RS232 for barcode reader (connector 2) <ul style="list-style-type: none"> protocol baud rate connector external inputs 	<p>Qty. 1</p> <p>Modbus master, Modbus slave and barcode reader</p> <p>9600, 19200, 38400</p> <p>SUB-D</p> <p>via the Modbus master/slave function, 24 analog and 24 binary</p>
Ethernet (connector 6) <ul style="list-style-type: none"> quantity protocols baud rate connector data format 	<p>max. 1</p> <p>TCP, IP, HTTP, DHCP, SMTP, ModbusTCP</p> <p>10 Mbits/sec, 100 Mbits/sec</p> <p>RJ45</p> <p>HTML</p>

6 Technical data (extract from data sheet)

USB host (connector 5) <ul style="list-style-type: none"> quantity use max. current 	2 (or 1 with stainless steel front), connector 5 and front connector (not with stainless steel front); no parallel operation for connecting a memory stick 100 mA
USB device (connector 15) <ul style="list-style-type: none"> quantity use 	2 (or 1 with stainless steel front), connector 15 and front connector (not with stainless steel front); no parallel operation for connecting to the (master) computer

6.5 Screen

Resolution/size	320 × 240 pixels/5.5"
Type/number of colors	TFT color screen/256 colors
Screen refresh rate	> 150 Hz
Brightness setting	adjustable on instrument
Screen saver (switch-off)	through waiting time or control signal

6.6 Electrical data

Supply voltage (switch-mode PSU)	AC 100 to 240V +10/-15%, 48 - 63Hz or AC/DC 20 to 30V, 48 - 63Hz (ELV)
Electrical safety Protection class I Test voltages (type test) <ul style="list-style-type: none"> mains supply circuit to meas. circuit mains supply circuit to housing (protective conductor) measuring current circuits to measuring current circuit and housing electrical isolation between analog inputs 	to EN 61010, Part 1, August 2002 overvoltage category II, pollution degree 2 terminal for PE conductor with AC supply: 2.3 kV/50 Hz, 1 min, with AC/DC supply: 2.3 kV/50 Hz, 1 min with AC supply: 2.3 kV/50 Hz, 1 min, with AC/DC supply: 2.3 kV/50 Hz, 1 min 500 V/50 Hz, 1 min up to 30 V AC and 50 V DC
Supply voltage error	< 0.1 % of range span
Power consumption	approx. 40 VA
Data backup	CompactFlash memory card
Electrical connection <ul style="list-style-type: none"> mains supply and relays analog and binary inputs 	at rear through pluggable screw terminals, 5.08 mm raster, max. conductor cross-section $\leq 2.5 \text{ mm}^2$ or $2 \times 1.5 \text{ mm}^2$ with ferrules at rear through pluggable screw terminals, 3.81 mm raster, max. conductor cross-section $\leq 1.5 \text{ mm}^2$

6 Technical data (extract from data sheet)

6.7 Environmental influences

Ambient temperature range	0 to +50 °C
Ambient temperature effect	0.03 %/°C
Storage temperature range	-20 to +60 °C
Climatic conditions	≤ 75 % relative humidity, no condensation
EMC	EN 61326-1
<ul style="list-style-type: none"> interference emission immunity to interference 	Class A - only for industrial use - to industrial requirements

6.8 Housing

Housing front	zinc die-casting, optionally in stainless steel (extra code)
Housing type	housing for flush-panel mounting to IEC 61554, in stainless steel
Bezel size	144 mm × 144 mm to IEC 61554
Depth behind panel	193 mm (incl. terminals)
Panel cut-out	138 ^{+1.0} mm × 138 ^{+1.0} mm to IEC 61554
Panel thickness	2 to 40 mm
Housing mounting	in panel to DIN 43834
Operating position	unrestricted, but taking into account the viewing angle of the screen, horizontally ±65°, vertically +40° to -65°
Enclosure protection	to EN 60529 Category 2, front IP65, rear IP20
Weight	approx. 3.5 kg

6.9 Approvals/marks of conformity

Mark of conformity	Testing laboratory	Certificates/certification numbers	Test basis	valid for
c UL us	Underwriters Laboratories	E 201387	UL 61010-1 CAN/CSA-C22.2 No. 61010-1	the flush-mounted instrument; not in conjunction with extra code 350
II 2G Ex px IIC II 2D Ex px IIIC IP65	electrosuisse	SEV 08 ATEX 0155 U	EN 60079-0:2009 EN 60079-2:2007 EN 61241-4:2006	the flush-mounted instrument; only in conjunction with extra code 444 and without extra code 350

A

Accessories 13

B

Back panel 20

C

Climatic conditions 15

Commissioning 5

CompactFlash 7

Connection diagram 20

D

Dimensions 15

Documentation, arrangement of 6

E

Electrical connection 17

Electrostatic discharge (ESD) 5

F

Functional test 29

I

Installation 15

Installation notes 17

Installation site 15

Instrument documentation in printed form 6

Instrument documentation in the form of PDF files 6

Instrument version, identification of 11

Introduction 5

M

Mounting 16

N

Note signs 9

7 Glossary

O

Order details 12

P

Panel mounting 16

R

Returning 5

S

Standard accessories 13

Start-up screen 29

T

Technical data 31

Typographical conventions 9

V

Views 15

Visualization level 29

W

Warning signs 9

Warranty 5



JUMO GmbH & Co. KG

Street address:
Moritz-Juchheim-Straße 1
36039 Fulda, Germany
Delivery address:
Mackenrodtstraße 14
36039 Fulda, Germany
Postal address:
36035 Fulda, Germany
Phone: +49 661 6003-0
Fax: +49 661 6003-607
E-mail: mail@jumo.net
Internet: www.jumo.net

JUMO Instrument Co. Ltd.

JUMO House
Temple Bank, Riverway
Harlow - Essex CM20 2DY, UK
Phone: +44 1279 63 55 33
Fax: +44 1279 63 52 62
E-mail: sales@jumo.co.uk
Internet: www.jumo.co.uk

JUMO Process Control, Inc.

6733 Myers Road
East Syracuse, NY 13057, USA
Phone: 315-437-5866
1-800-554-5866
Fax: 315-437-5860
E-mail: info.us@jumo.net
Internet: www.jumousa.com