

JUMO LOGOSCREEN nt
Paperless Recorder
with TFT display,
CompactFlash card and
USB interfaces

B 706581.4
Installation Instructions

2009-12-11/00504673

Contents

1	Introduction	5
1.1	Preface	5
1.2	Arrangement of the documentation	6
1.3	Typographical conventions	8
2	Identifying the instrument version	9
2.1	Nameplate	9
2.2	Type designation	10
2.3	Standard accessories	11
2.4	Accessories (data sheet 709700)	11
3	Installation	13
3.1	Installation site and climatic conditions	13
3.2	Mounting	13
4	Electrical connection	15
4.1	Installation notes	15
4.2	Procedure	16
4.3	Overview of the electrical isolation	17
4.4	Connection diagram	18
4.5	Connection examples concerning binary inputs/outputs	24
5	Functional test	27
6	Technical data (extract from data sheet)	29
7	Glossary	33

Contents

1.1 Preface



Please read these Operating Instructions before commissioning the instrument. Keep the manual in a place that is accessible to all users at all times.

Please assist us to improve this operating manual, where necessary.

Your comments will be appreciated.



If any difficulties should arise during commissioning, you are asked not to carry out any manipulations that could endanger your rights under the instrument warranty!

Please contact the nearest subsidiary or the head office in such a case.



When returning modules, assemblies or components, the regulations of EN 61340-5-1 and EN 61340-5-2 "Protection of electronic devices from electrostatic phenomena" must be observed. Use only the appropriate **ESD** packaging for transport.

Please note that we cannot accept any liability for damage caused by ESD.

ESD=electrostatic discharge

1 Introduction

1.2 Arrangement of the documentation

The documentation for this instrument is addressed to equipment manufacturers (OEMs) and users with appropriate technical expertise. It consists of the following parts:

Instrument documentation in printed form

B 706581.1 Operating Instructions

The operating instructions are an extract from the operating manual and cover the basic operation of the paperless recorder.

B 706581.4(.1) Installation Instructions

The installation instructions describe the installation of the recorder and the connection of the supply and signal cables. The instructions also contain a list of the technical data.

B 706581.4 Installation instructions for recorders with die-cast zinc front

B 706581.4.1 Installation instructions for recorders with stainless steel front

Instrument documentation in the form of PDF files

The “Instrument documentation in the form of PDF files” is on the CD that is included in the delivery.

B 706581.0 Operating Manual

It contains information about commissioning, operation, parameterization and configuration on the instrument.

B 706581.1 Operating Instructions

The operating instructions are an extract from the operating manual and cover the basic operation of the paperless recorder.

B 706581.2.0 Interface Description (serial interfaces)

This provides information on the communication (RS232/RS485) with supervisory systems.

Interface Description (Ethernet interface)

This provides information on the connection of a paperless recorder to a company-internal network. This description is integrated into B 706581.2.0.

B 706581.2.3 Interface Description (PROFIBUS-DP interface)

This provides information on the connection of a paperless recorder to a PROFIBUS-DP system.

B 706581.4(.1) Installation Instructions

The installation instructions describe the installation of the recorder and the connection of the supply and signal cables. The instructions also contain a list of the technical data.

B 706581.4 Installation instructions for recorders with die-cast zinc front

B 706581.4.1 Installation instructions for recorders with stainless steel front

B 706581.6 Setup Program

The manual describes the function of the setup program. The setup program is available as an option.

T 706581 Data Sheet

The data sheet contains general information, the order details and the technical data.

B 709701.0 PC Evaluation software (PCA3000)

The operating manual describes the operation and the features of the PC evaluation software.

PCA3000 serves to visualize and evaluate process data (measurement data, batch data, messages ...). The process data can be read in via the CompactFlash memory card, or made available through the PCC software.

B 709702.0 PCA Communications software (PCC)

The operating manual describes the operation and the features of the PCA Communications software.

PCC is responsible for the data transfer from the recorder to a PC, or to a network.



All documents are available for downloading at www.jumo.net

1 Introduction

1.3 Typographical conventions

Warning signs

The signs for **Danger** and **Caution** are used in this manual under the following conditions:



Danger

This symbol is used when there may be **danger to personnel** if the instructions are ignored or not followed correctly!



Caution

This symbol is used when there may be **damage to equipment or data** if the instructions are ignored or not followed correctly!



Caution

This symbol is used where special care is required when handling **components liable to damage through electrostatic discharge**.

Note signs



Note

This symbol is used when your **special attention** is drawn to a remark.



Reference

This symbol refers to **further information** in other manuals, chapters or sections.

abc¹

Footnote

Footnotes are remarks that **refer to specific points** in the text. Footnotes consist of two parts:

A marker in the text, and the footnote text.

The markers in the text are arranged as continuous superscript numbers.

Action instruction

*

This symbol indicates that an **action to be performed** is described.

The individual steps are marked by this asterisk, e.g.

* Rotate control knob

* Press control knob

2 Identifying the instrument version

2.1 Nameplate

Position The nameplate is glued onto the paperless recorder.

Contents It contains important information, such as:

Description	Designation on the nameplate	Example
Device type	Typ	706581/18-321-33/020
Sales No.	VARTN	70/00xxxxxx
Serial No.	F-Nr	0022969000008050006
Supply voltage		110 – 240V AC +10/-15%, 48 – 63Hz

Type Please check the type supplied against your order document. Refer to Chapter 2.2 “Type designation” for identification of the type.

VARTN The Sales No. provides an unambiguous definition of an article from the catalog. It is used in communication between the sales department and the customer.

F-Nr The serial number (F-Nr.) indicates the production date (year/week). The figures concerned are in positions 12, 13, 14, 15.

Example:

F-Nr 002296900000**0805**0006

This shows that the paperless recorder was manufactured in 2008, week 5.

2 Identifying the instrument version

2.2 Type designation

	Basic type
706581/	Paperless recorder with Ethernet, USB and RS232/RS485 interfaces and RS232 interface (to connect a barcode reader) and one relay

	Basic type extensions
	Software
0	No software package
1	With software package (setup program incl. USB cable, PC Evaluation software PCA3000, PCA Communications software PCC)
	Language for instrument texts
8	Factory setting (English/German)
9	Set to customer specification

1	2	3	Module slots
			Slot 1 (bottom)
0			not used
2			3 analog inputs and 8 binary inputs/outputs
3			6 analog inputs
			Slot 2 (middle)
0			not used
2			3 analog inputs and 8 binary inputs/outputs
3			6 analog inputs
			Slot 3 (top)
0			not used
1			6 relay outputs
2			3 analog inputs and 8 binary inputs/outputs
3			6 analog inputs

	Supply
33	100 - 240V AC +10/-15 %, 48 - 63Hz
25	20 - 30V AC/DC, 48 - 63Hz

	Extra codes
020	Lithium battery for memory buffering (ex-factory)
021	Storage capacitor (instead of extra code 020)
260	Math and logic module
267	PROFIBUS-DP interface
350	Universal carrying case TG-35 ¹
444	Stainless steel front with touchpad 

706581/

--

 -

--

 -

--

 /

--

² (Order code)

706581/

1

8

 -

3

2

1

 -

33

 /

020

 (Order example)

¹ This extra code is available in combination with supply voltage 100–240V AC, not with low supply voltage. UL and ATEX approvals not applicable. The protection type in the carrying case corresponds to IP20, outside IP20D.
² List extra codes in sequence, separated by commas.

2 Identifying the instrument version

2.3 Standard accessories

- 1 Installation Instructions B 706581.4
- 1 Operating Instructions B 706581.1
- 4 mounting brackets
- 1 panel seal
- 1 CD with detailed operating instructions and supplementary documentation (see Chapter 1.2 “Arrangement of the documentation”)

2.4 Accessories (data sheet 709700)

- Setup program (incl. USB cable)
- PC Evaluation software (PCA3000)
- PCA Communications software (PCC)
- CompactFlash memory cards
- USB memory sticks

2 Identifying the instrument version

3.1 Installation site and climatic conditions

The installation site should be as free as possible from vibration. Electromagnetic fields, such as those caused by motors, transformers etc. should be avoided as far as possible.

The ambient temperature at the site can be 0 to 50°C, at a relative humidity of $\leq 75\%$, no condensation.

⇒ Chapter 4.1 “Installation notes”

3.2 Mounting

Views

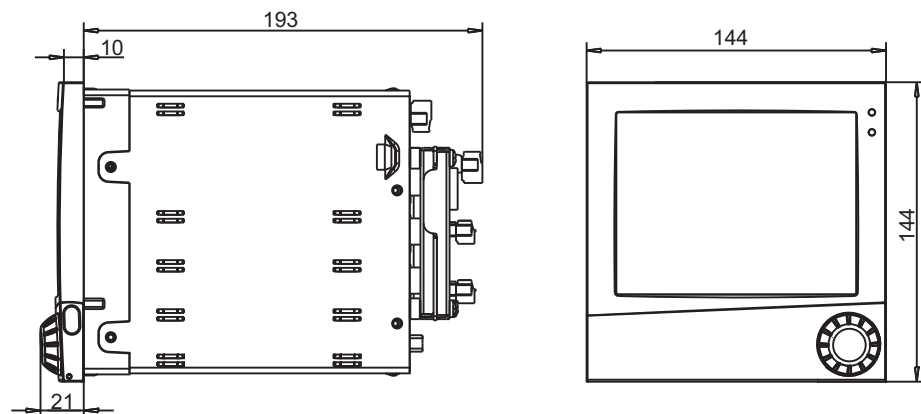

Panel cut-out

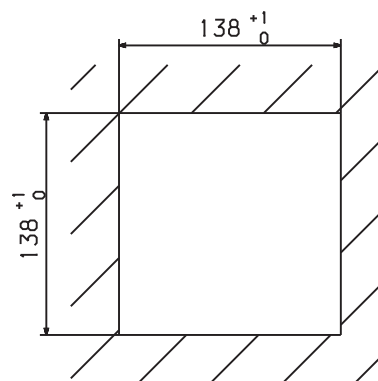

3 Installation

Mounting in a panel

- * Fit panel seal (IP65 seal).

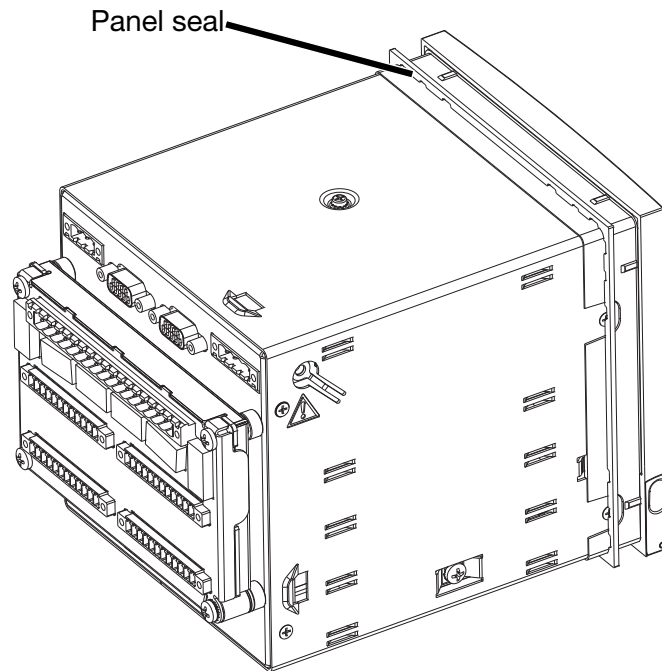

- * Insert the paperless recorder from the front into the panel cut-out.
- * From behind the panel, hook the four mounting brackets into the grooves on the sides of the housing and tighten them evenly up against the back of the panel.

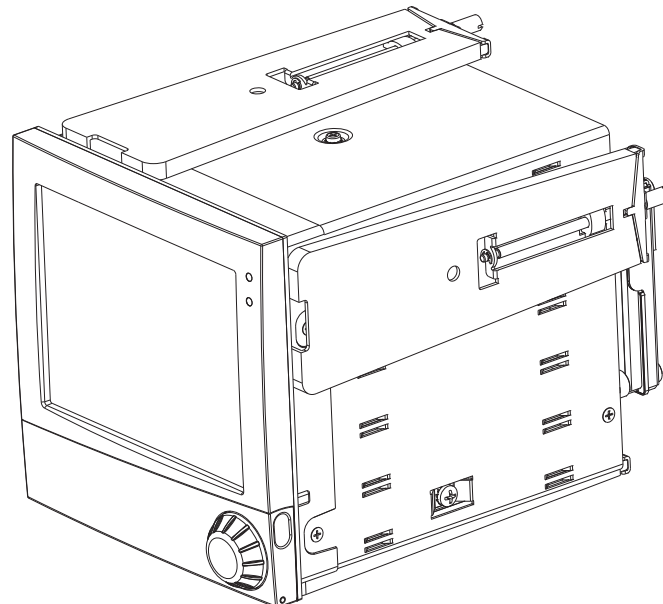

4.1 Installation notes

- The device is designed for installation in electrical cabinets, machines, or systems. External fuse protection and shut-off must be provided for the device. The fuse must not exceed 20 A.

An instrument fuse is already built into the device itself (depending on the device design).

20 – 30V AC/DC, 48 – 63Hz : fuse 2.5A slow-blow

100 – 240V AC +10/-15%, 48 – 63Hz : fuse 1.25A slow-blow

- The choice of cable, the installation and the electrical connection must conform to the requirements of VDE 0100 “Regulations on the Installation of Power Circuits with Nominal Voltages below 1000V” or the appropriate local regulations.
- Work inside the instrument must only be carried out to the extent described and, like the electrical connection, only by qualified personnel.
- For service and repair work the device must be disconnected from the power supply (all poles).
- To generate the operating voltage of 20...30 V for Extra Low Voltage (ELV), the maximum nominal voltage of an external power supply must not exceed 240 V (line-to-line and line-to-neutral). If the external nominal voltage is greater than 240 V, an Safety Extra Low Voltage (SELV) power supply must be used. For line-to-line supply of the external power supply, the power supply must have all-pole fuse protection. The fuse must shut off both connections.
- Run input, output and supply cables separately and not parallel to one another.
- In EMC disturbed environments, all input and output cables without connection to the mains supply must be arranged as twisted and screened cables. Earth the screen on the instrument side to the earth potential.
- Ground the instrument at the PE terminal of the supply voltage connector to the protective earth conductor. This cable must have the same cross-section as that used for the supply cables. Earthing cables must be wired in a star configuration to a common earth point that is connected to the protective earth conductor of the electrical supply.
- Do not connect any additional loads to the supply terminals of the instrument.
- The device is not suitable for use in areas with an explosion hazard (**Ex** areas).
- Electromagnetic compatibility (EMC) conforms to the standards and regulations cited in the technical data.
⇒ Chapter 6 “Technical data (extract from data sheet)”
- Inductive loads close to the instrument, such as contactors or solenoid valves, should have RC modules fitted for interference suppression.

4 Electrical connection

4.2 Procedure

- * Make the electrical connection as per Chapter 4.4 "Connection diagram".
- * Apply strain relief for the connecting cables, if necessary.

Instrument variant 1

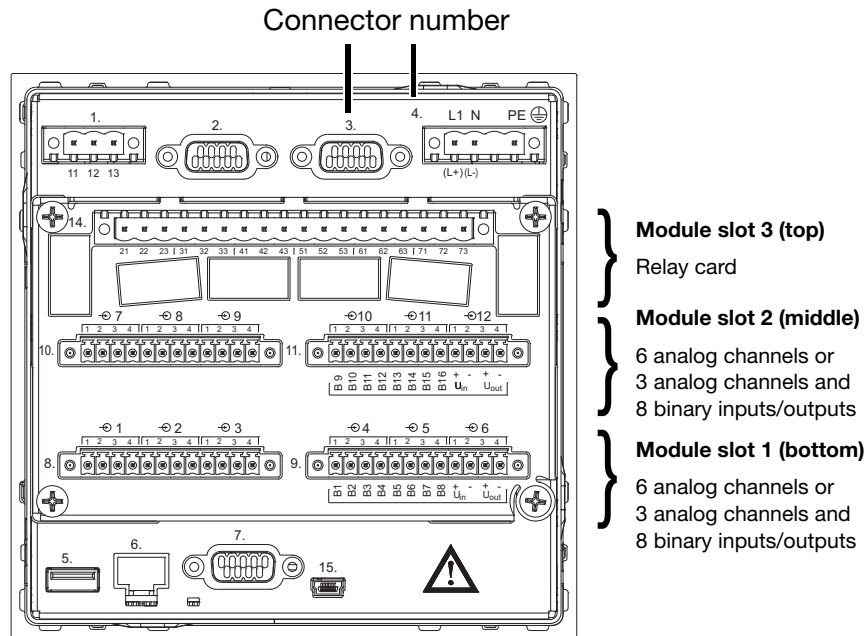

Instrument variant 2

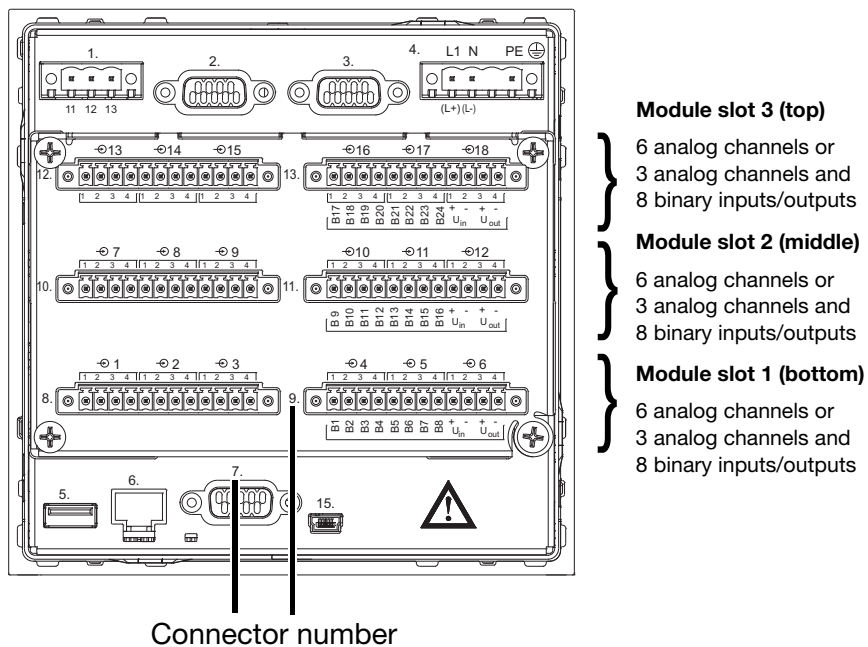

4 Electrical connection

Connector summary

Connector/slot	Function
1	Relay output
2	RS232 for barcode reader
3	PROFIBUS-DP
4	Supply voltage
5	USB host interface
6	Ethernet
7	RS232 and RS485
8	Analog input
9	Analog input or binary inputs/outputs
10	Analog input
11	Analog input or binary inputs/outputs
12	Analog input
13	Analog input or binary inputs/outputs
14	Relay card (for instrument variant 1)
15	USB device interface

4.3 Overview of the electrical isolation

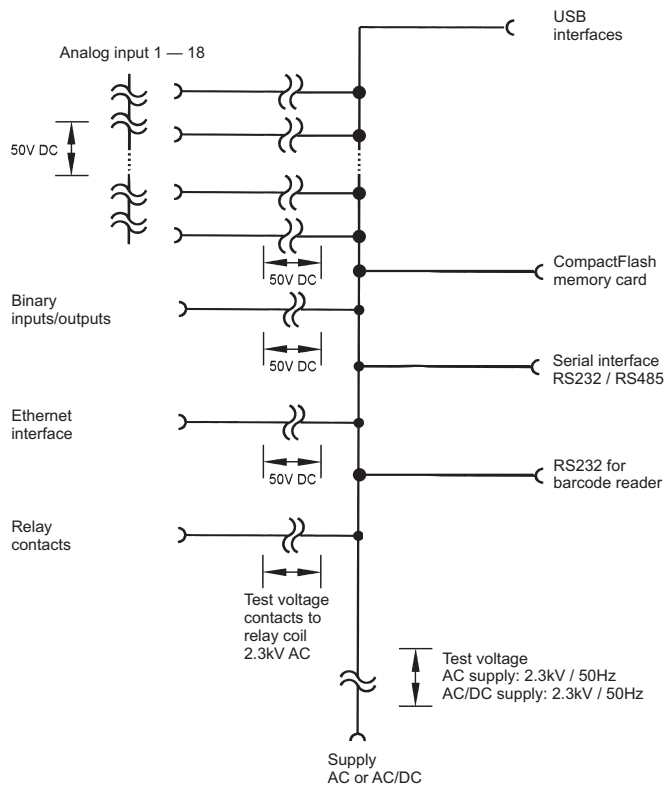

4 Electrical connection

4.4 Connection diagram



The electrical connection must only be carried out by specialist personnel.

Back panel ⇒ Chapter 4.2 “Procedure”

Connections

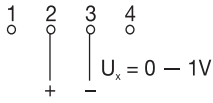
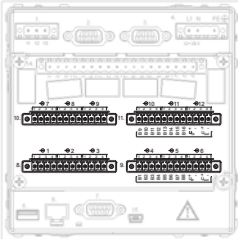
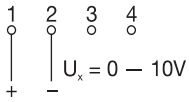
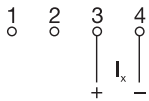
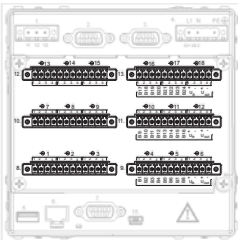

	Terminal assignment	Connector	Diagram
Supply voltage	Supply voltage as on nameplate	Connector 4 L1 (L+) N (L-) PE	
Analog inputs	Thermocouple	Connectors 8 to 11 (input 1 – 12) for instrument variant 1 or connectors 8 to 13 (input 1 – 18) for instrument variant 2 	
	RTD 2-wire circuit		
	RTD 3-wire circuit		
	RTD 4-wire circuit		
	Resistance transmitter E = end S = slider A = start		
	Potentiometer in 2-wire circuit		
	Potentiometer in 3-wire circuit		
	Potentiometer in 4-wire circuit		

4 Electrical connection

	Terminal assignment	Connector	Diagram
Analog inputs	Voltage input 0 – 1V	Connectors 8 to 11 (input 1 – 12) for instrument variant 1	
	Voltage input 0 – 10V		
	Current input		
		<p>or</p> <p>connectors 8 to 13 (input 1 – 18) for instrument variant 2</p> 	

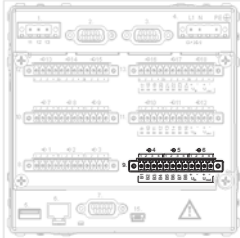
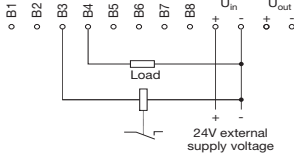
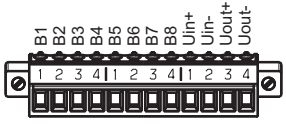
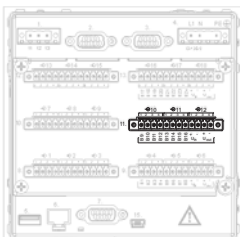

4 Electrical connection

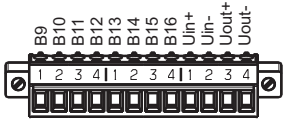
Binary inputs/ outputs

Terminal assignment	Connector	Diagram
 <p>The configuration in the instrument or in the setup program defines whether it is a binary input or binary output.</p>		
<p>B1 ... B8</p> <p>voltage-controlled LOW = -3 to +5V DC HIGH = 12 to 30V DC</p> <p>B1 Binary input/output 1 B2 Binary input/output 2 B3 Binary input/output 3 B4 Binary input/output 4 B5 Binary input/output 5 B6 Binary input/output 6 B7 Binary input/output 7 B8 Binary input/output 8</p> <p>U_{in+} external supply voltage U_{in-} ground U_{out+} +24V (60mA) internal supply voltage U_{out-} ground</p>	<p>Connector 9</p> <p>only for modules with 3 analog inputs</p> 	 <p>Example: Connecting a load to binary output 4 (B4) and a solid-state relay to binary output 3 (B3) requires an external supply voltage.</p> <p>Diagram of the connector:</p> 
<p>B9 ... B16</p> <p>voltage-controlled LOW = -3 to +5V DC HIGH = 12 to 30V DC</p> <p>B9 Binary input/output 9 B10 Binary input/output 10 B11 Binary input/output 11 B12 Binary input/output 12 B13 Binary input/output 13 B14 Binary input/output 14 B15 Binary input/output 15 B16 Binary input/output 16</p> <p>U_{in+} external supply voltage U_{in-} ground U_{out+} +24V (60mA) internal supply voltage U_{out-} ground</p>	<p>Connector 11</p> <p>only for modules with 3 analog inputs</p> 	 <p>Example: Binary input 12 (B12) is operated from the internal supply voltage.</p> <p>Diagram of the connector:</p> 



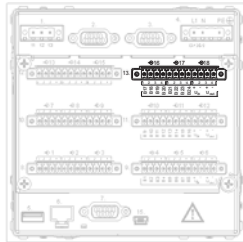
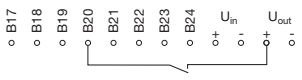
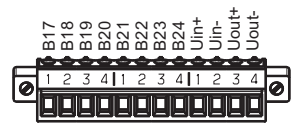

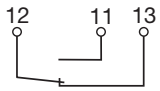
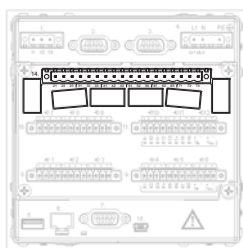
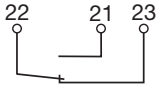
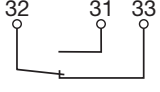
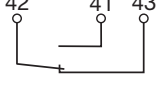
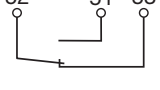
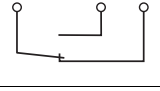
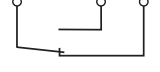

4 Electrical connection

Binärein-/ -ausgänge

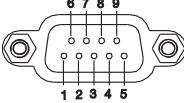

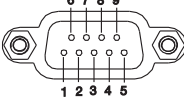
Terminal assignment	Connector	Diagram
<p>B17 ... B24</p> <p>voltage-controlled LOW = -3 to +5V DC HIGH = 12 to 30V DC</p> <p>B17 Binary input/output 17 B18 Binary input/output 18 B19 Binary input/output 19 B20 Binary input/output 20 B21 Binary input/output 21 B22 Binary input/output 22 B23 Binary input/output 23 B24 Binary input/output 24</p> <p>U_{in+} external supply voltage U_{in-} ground U_{out+} +24V (60mA) internal supply voltage U_{out-} ground</p>	<p>Connector 13</p> <p>only for instrument variant 2 and on modules with 3 analog inputs</p> 	 <p>Example: Binary input 20 (B20) is operated from the internal supply voltage.</p> <p>Diagram of the connector:</p> 
<p>Relay 1 - alarm changeover (SPDT)</p>	<p>Connector 1</p> 	
<p>Relay 2 changeover (SPDT)</p>	<p>Connector 14</p> <p>only for instrument variant 1</p> 	
<p>Relay 3 changeover (SPDT)</p>		
<p>Relay 4 changeover (SPDT)</p>		
<p>Relay 5 changeover (SPDT)</p>		
<p>Relay 6 changeover (SPDT)</p>		
<p>Relay 7 changeover (SPDT)</p>		

Relay outputs

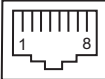
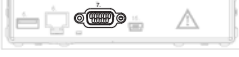
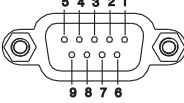
4 Electrical connection

Terminal assignment	Connector	Diagram
<p>Interfaces</p> <p>RS232C for barcode reader 9-pin SUB-D socket connector</p> <p>2 RxD receive data 3 TxD transmit data 5 GND ground</p>	<p>Connector 2</p> 	
<p>PROFIBUS-DP 9-pin SUB-D socket connector (extra code)</p> <p>3 RxD/TxD-P B conductor Receive/transmit data positive 5 DGND Data transmission ground 6 VP supply voltage positive 8 RxD/TxD-N A conductor Receive/transmit data negative</p>	<p>Connector 3</p> 	
<p>USB host interface for memory sticks</p> <p>The recorder without stainless steel front also has a USB host interface on the front panel, connected in parallel. The two interfaces cannot both be operated at the same time.</p>	<p>Connector 5</p> 	
<p>Ethernet RJ45 socket connector</p> <p>1 TX+ transmit data + 2 TX- transmit data - 3 RX+ receive data + 6 RX- receive data -</p>	<p>Connector 6</p> 	
<p>RS232C 9-pin SUB-D socket connector (switchable to RS485)</p> <p>2 RxD receive data 3 TxD transmit data 5 GND ground</p>	<p>Connector 7</p> 	

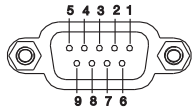
4 Electrical connection

Terminal assignment	Connector	Diagram
<p>RS485 9-pin SUB-D socket connector (switchable to RS232)</p> <p>3 TxD+/RxD+ Transmit/receive data +</p> <p>5 GND ground</p> <p>8 TxD-/RxD- Transmit/receive data -</p>	<p>Connector 7</p> 	
<p>USB device interface for connecting a PC</p> <p>The recorder without stainless steel front also has a USB device interface on the front panel, connected in parallel. The two interfaces cannot both be operated at the same time.</p>	<p>Connector 15</p> 	

4 Electrical connection

4.5 Connection examples concerning binary inputs/outputs

Binary inputs Triggering via external relays and external supply voltage:

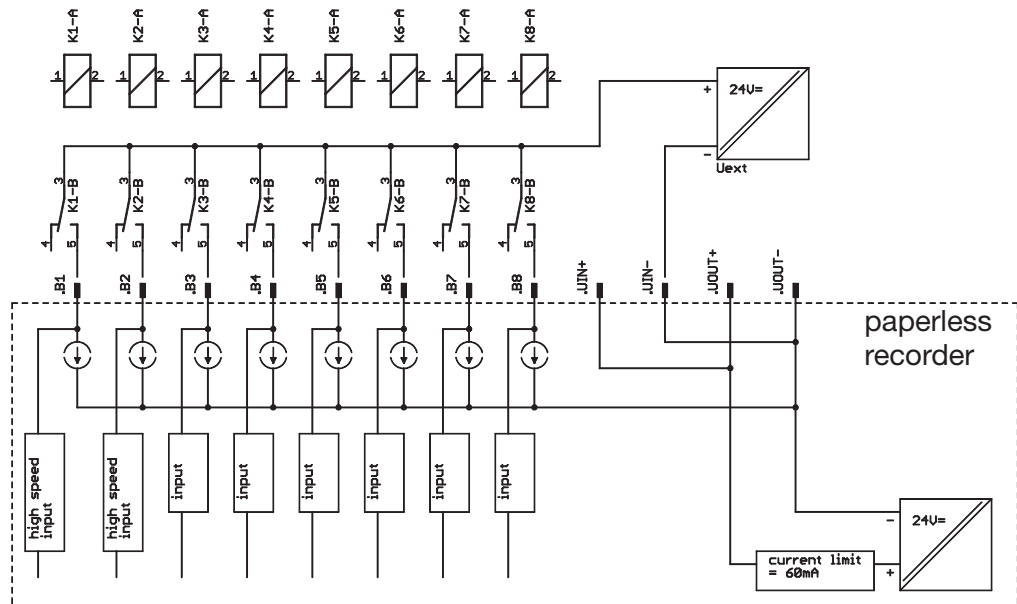

Triggering via external relays and internal supply voltage:

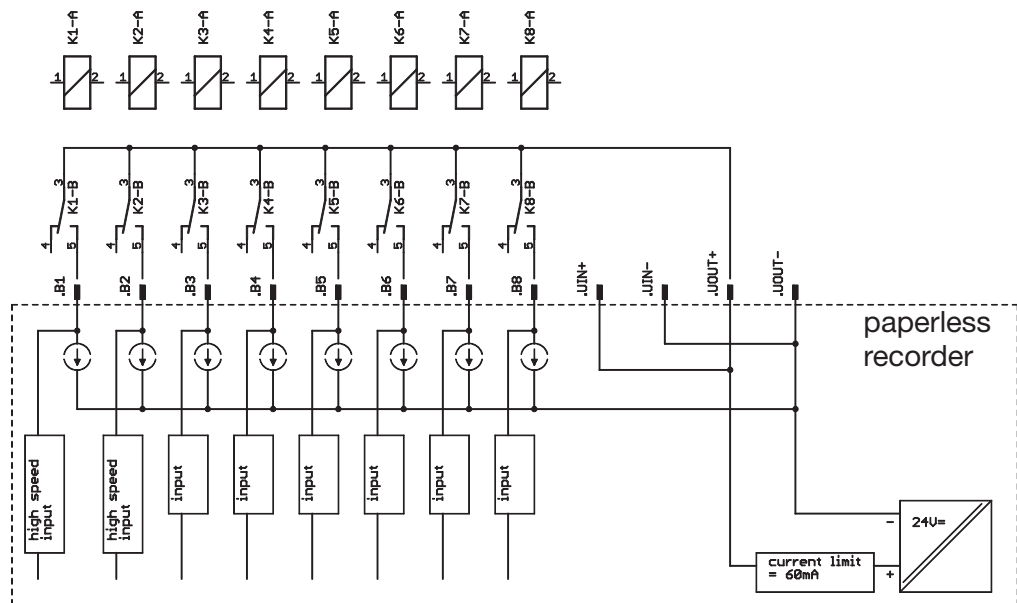

4 Electrical connection

Triggering via external opto-coupler and internal supply voltage:

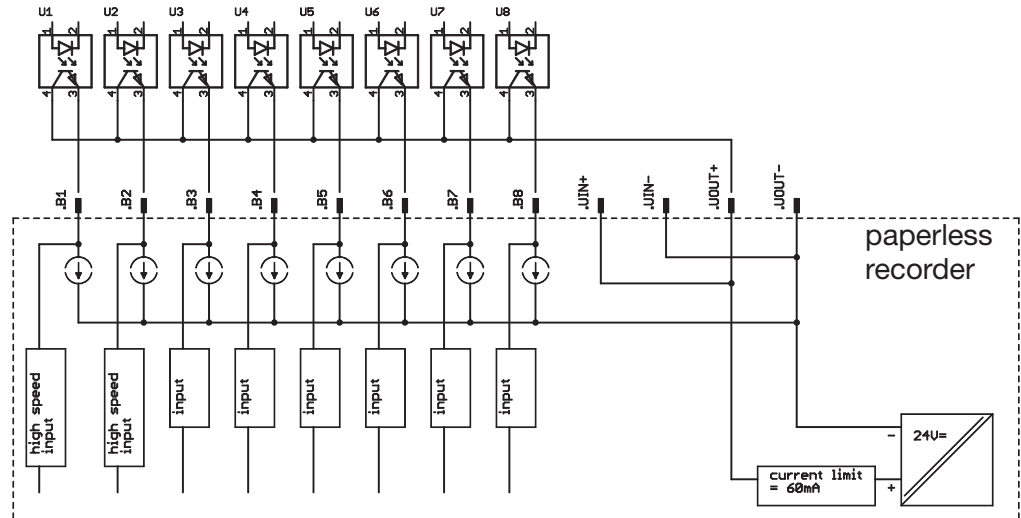

Triggering via external switches (potential-free) and internal supply voltage:

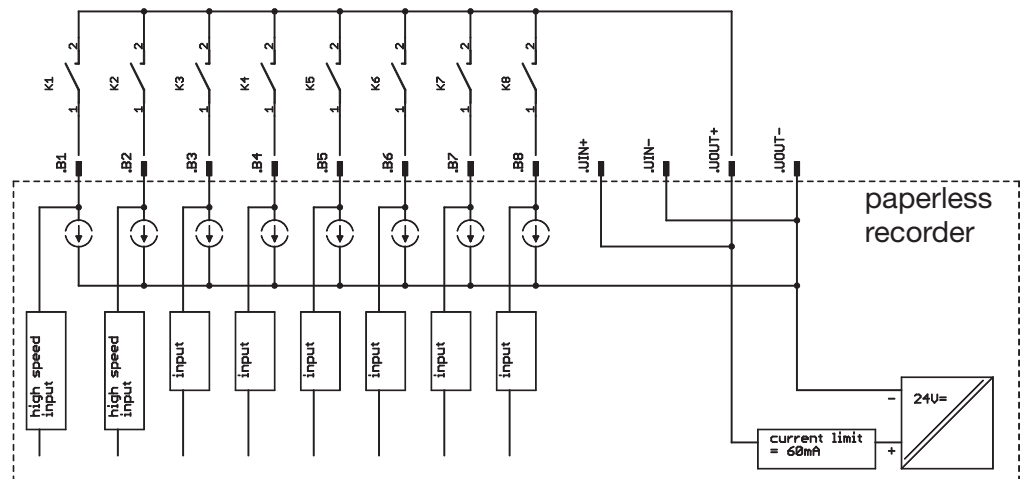

4 Electrical connection

Binary outputs

Triggering of external relays via external supply voltage:

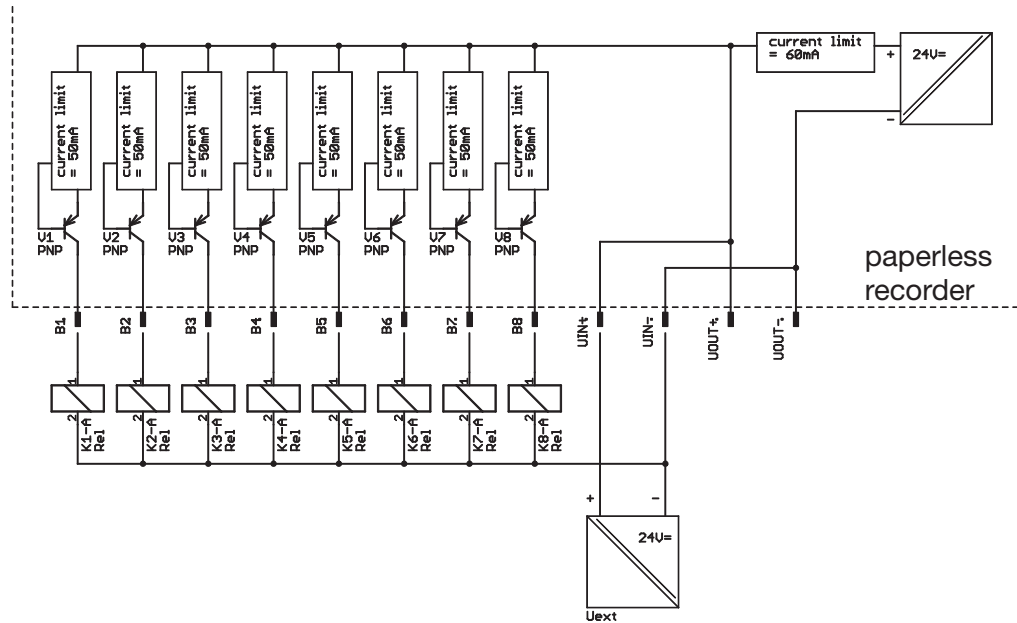

Triggering of external relays via internal supply voltage:

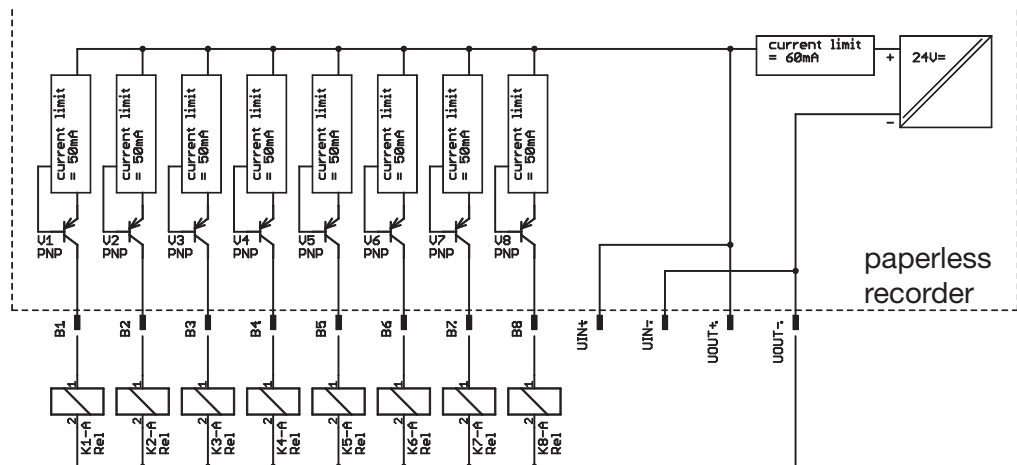

By triggering the external relays via the internal supply voltage the total current must not exceed 60mA.

5 Functional test

After the paperless recorder has been installed and wired up, it can be commissioned. After applying or switching on the supply voltage, the start-up screen will appear for a short time.

Start-up screen

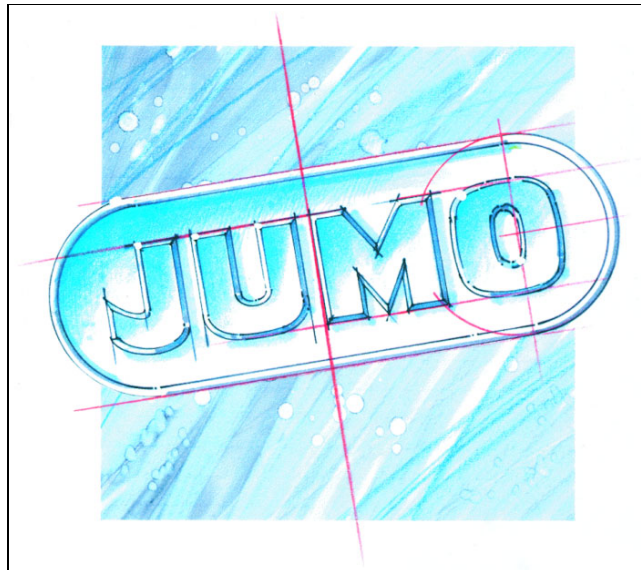

The visualization will start automatically after the initialization phase.

Visualization

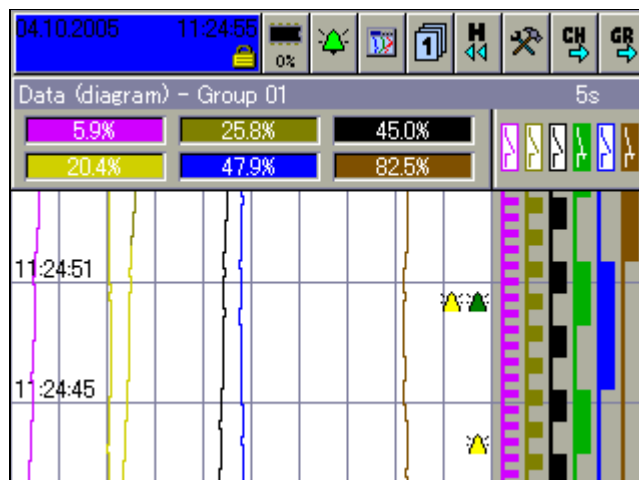

The paperless recorder is now in the recording phase.

Further steps



The recorder can be configured by an authorized person, either by using the control knob (rotating and pressing) or with the help of the PC setup program.

Further information about configuration can be found in the Operating Manual B 706581.0.

Finally, make another check that the connection, configuration and function of the recorder are all correct.

5 Functional test

6 Technical data (extract from data sheet)

Analog inputs

Thermocouple

Designation	Type	Standard	Meas. range	Accuracy ¹
Fe-CuNi	L	DIN 43 710	-200 to +900°C	±0.1%
Fe-CuNi	J	EN 60 584	-200 to +1200°C	±0.1% from -100°C
Cu-CuNi	U	DIN 43 710	-200 to +600°C	±0.1% from -150°C
Cu-CuNi	T	EN 60 584	-270 to +400°C	±0.1% from -150°C
NiCr-Ni	K	EN 60 584	-200 to +1372°C	±0.1% from -80°C
NiCr-CuNi	E	EN 60 584	-200 to +1000°C	±0.1% from -80°C
NiCrSi-NiSi	N	EN 60 584	-100 to +1300°C	±0.1% from -80°C
Pt10Rh-Pt	S	EN 60 584	0 to 1768°C	±0.15%
Pt13Rh-Pt	R	EN 60 584	0 to 1768°C	±0.15%
Pt30Rh-Pt6Rh	B	EN 60 584	0 to 1820°C	±0.15% from 400°C
W3Re/W25Re	D		0 to 2495°C	±0.15% from 500°C
W5Re/W26Re	C		0 to 2320°C	±0.15% from 500°C
W3Re/W26Re			0 to 2400°C	±0.15% from 500°C
Chromel-copel		GOST R 8.585-2001	-200 to +800°C	±0.15% from -80°C
Chromel-alumel		GOST R 8.585-2001	-200 to +1372°C	±0.1% from -80°C
PLII (Platinel II)			0 to 1395°C	±0.15%
Shortest span	Type L, J, U, T, K, E, N, chromel-alumel, PLII: 100°C Type S, R, B, D, C, W3Re/W26Re, chromel-copel: 500°C			
Range start/end	freely programmable within the limits, in 0.1°C steps			
Cold junction	Pt100 internal or thermostat external constant			
Cold junction accuracy (internal)	± 1°C			
Cold junction temperature (external)	-50 to +150°C adjustable			
Sampling cycle	Channel 1 - 18: 125ms in total			
Input filter	2nd order digital filter; filter constant adjustable from 0 to 10.0 sec			
Electrical isolation	see "Electrical data" on page 5 and "Overview of the electrical isolation" on page 16			
Resolution	> 14 bit			
Features	also programmable in °F			

¹ The linearization accuracy refers to the maximum measuring range. The linearization accuracy is reduced with short spans.

Resistance thermometer

Designation	Standard	Connection circuit	Meas. range	Accuracy ¹	Meas. curr.
Pt100	EN 60 751 (TC = $3.85 \cdot 10^{-3} 1/^{\circ}\text{C}$)	2/3-wire	-200 to +100°C	±0.5°C	≈ 250 μA
		2/3-wire	-200 to +850°C	±0.8°C	≈ 250 μA
		4-wire	-200 to +850°C	±0.5°C	≈ 250 μA
Pt100	JIS 1604 (TC = $3.917 \cdot 10^{-3} 1/^{\circ}\text{C}$)	2/3-wire	-200 to +100°C	±0.5°C	≈ 250 μA
		2/3-wire	-200 to +650°C	±0.8°C	≈ 250 μA
		4-wire	-200 to +650°C	±0.5°C	≈ 250 μA
Pt100	GOST 6651-94 A.1 (TC = $3.91 \cdot 10^{-3} 1/^{\circ}\text{C}$)	2/3-wire, 4-wire	-200 to +100°C	±0.5°C	≈ 250 μA
		2/3-wire, 4-wire	-200 to +850°C	±0.8°C	≈ 250 μA
Pt500	EN 60 751 (TC = $3.85 \cdot 10^{-3} 1/^{\circ}\text{C}$)	2/3-wire, 4-wire	-200 to +100°C	±0.5°C	≈ 100 μA
		2/3-wire, 4-wire	-200 to +850°C	±0.9°C	≈ 100 μA
Pt1000	EN 60 751 (TC = $3.85 \cdot 10^{-3} 1/^{\circ}\text{C}$)	2/3-wire	-200 to +100°C	±0.5°C	≈ 100 μA
		2/3-wire	-200 to +850°C	±0.8°C	≈ 100 μA
		4-wire	-200 to +850°C	±0.5°C	≈ 100 μA
Ni 100	DIN 43 760 (TC = $6.18 \cdot 10^{-3} 1/^{\circ}\text{C}$)	2/3-wire, 4-wire	-60 to +180°C	±0.4°C	≈ 250 μA
Pt50	ST RGW 1057 1985 (TC = $3.91 \cdot 10^{-3} 1/^{\circ}\text{C}$)	2/3-wire	-200 to +100°C	±0.5°C	≈ 250 μA
		2/3-wire	-200 to +1100°C	±0.9°C	≈ 250 μA
		4-wire	-200 to +100°C	±0.5°C	≈ 250 μA
		4-wire	-200 to +1100°C	±0.6°C	≈ 250 μA
Cu 50	(TC = $4.26 \cdot 10^{-3} 1/^{\circ}\text{C}$)	2/3-wire	-50 to +100°C	±0.5°C	≈ 250 μA
		2/3-wire	-50 to +200°C	±0.9°C	≈ 250 μA
		4-wire	-50 to +100°C	±0.5°C	≈ 250 μA
		4-wire	-50 to +200°C	±0.7°C	≈ 250 μA

6 Technical data (extract from data sheet)

Designation	Standard	Connection circuit	Meas. range	Accuracy ¹	Meas. curr.
Cu 100	GOST 6651-94 A.4 (TC = $4.26 \cdot 10^{-3} 1/^{\circ}\text{C}$)	2/3-wire 2/3-wire 4-wire 4-wire	-50 to +100°C -50 to +200°C -50 to +100°C -50 to +200°C	$\pm 0.5^{\circ}\text{C}$ $\pm 0.9^{\circ}\text{C}$ $\pm 0.5^{\circ}\text{C}$ $\pm 0.6^{\circ}\text{C}$	$\approx 250\mu\text{A}$ $\approx 250\mu\text{A}$ $\approx 250\mu\text{A}$ $\approx 250\mu\text{A}$
Connection circuit	2-, 3-, or 4-wire circuit				
Shortest span	15°C				
Sensor lead resistance	max. 30 per conductor for 3-wire/4-wire circuit max. 10 per conductor for 2-wire circuit				
Range start/end	freely programmable within the limits, in 0.1°C steps				
Sampling cycle	Channel 1 - 18: 125ms in total				
Input filter	2nd order digital filter; filter constant adjustable from 0 to 10 sec				
Electrical isolation	see "Electrical data" on page 5 and "Overview of the electrical isolation" on page 16				
Resolution	>14 bit				
Features	also programmable in °F				

¹ The linearization accuracy refers to the maximum measuring range. The linearization accuracy is reduced with short spans.

Resistance transmitter and potentiometer

Designation	Meas. range	Accuracy ¹	Meas. curr.
Resistance transmitter	up to 4000Ω	$\pm 4\Omega$	$\approx 100\mu\text{A}$
Potentiometer	< 400Ω ≥ 400Ω to 4000Ω	$\pm 400\text{m}\Omega$ $\pm 4\Omega$	$\approx 250\mu\text{A}$ $\approx 100\mu\text{A}$
Connection circuit	resistance transmitter: 3-wire circuit potentiometer: 2-/3-/4-wire circuit		
Shortest span	60Ω		
Sensor lead resistance	max. 30 per conductor for 4-wire circuit max. 10 per conductor for 2-/3-wire circuit		
Resistance values	freely programmable within the limits, in 0.1 steps		
Sampling cycle	Channel 1 - 18: 125ms in total		
Input filter	2nd order digital filter; filter constant adjustable from 0 to 10.0 sec		
Electrical isolation	see "Electrical data" on page 5 and "Overview of the electrical isolation" on page 16		
Resolution	>14 bit		

¹ The linearization accuracy refers to the maximum measuring range. The linearization accuracy is reduced with short spans.

Input for DC voltage, DC current

Basic range	Accuracy ¹	Input resistance
-12 to +112mV -10 to +210mV -1.5 to +11.5V -0.12 to +1.12V -1.2 to +1.2V -11.2 to +11.2V	$\pm 100\mu\text{V}$ $\pm 240\mu\text{V}$ $\pm 6\text{mV}$ $\pm 1\text{mV}$ $\pm 2\text{mV}$ $\pm 12\text{mV}$	$R_E \geq 1\text{M}\Omega$ $R_E \geq 470\text{k}\Omega$ $R_E \geq 470\text{k}\Omega$ $R_E \geq 470\text{k}\Omega$ $R_E \geq 470\text{k}\Omega$ $R_E \geq 470\text{k}\Omega$
Shortest span	5mV	
Range start/end	freely programmable within the limits in 0.01 mV steps	
-1.3 to +22mA -22 to +22mA	$\pm 20\mu\text{A}$ $\pm 44\mu\text{A}$	burden voltage $\leq 3\text{V}$ burden voltage $\leq 3\text{V}$
Shortest span	0.5mA	
Range start/end	freely programmable within the limits in 0.01 mA steps	
Overrange/underrange	according to NAMUR NE 43	
Sampling cycle	Channel 1 - 18: 125ms in total	
Input filter	2nd order digital filter; filter constant adjustable from 0 to 10.0 sec	
Electrical isolation	see "Electrical data" on page 5 and "Overview of the electrical isolation" on page 16	
Resolution	>14 bit	

¹ The linearization accuracy refers to the maximum measuring range. The linearization accuracy is reduced with short spans.

6 Technical data (extract from data sheet)

Transducer short circuit/break

	Short-circuit ¹	Break ¹
Thermocouple	not detected	detected
Resistance thermometer	detected	detected
Resistance transmitter	not detected	detected
Potentiometer	not detected	detected
Voltage $\leq \pm 210\text{mV}$	not detected	detected
Voltage $> \pm 210\text{mV}$	not detected	not detected
Current	not detected	not detected

¹ Programmable reaction of device, e.g. triggering alarm

Binary inputs/outputs (option)

Input or output	configurable as input or output
Number	8, 16 or 24, depending on the device version, to DIN VDE 0411, Part 500; max. 25Hz, max. 32V
Input - level - counting frequency	logic "0": -3 to +5V (input current max. $\pm 1\text{mA}$), logic "1": 12 to 30V ($2.5\text{mA} \leq$ input current $\leq 5\text{mA}$) 8Hz
High-speed input - task - counting frequency	the first two binary inputs of each module (B1, B2, B9, B10, B17, B18), if the module is not fitted with relays or 6 analog inputs count function, e.g. for flow measurement 10kHz
Output - type - level - sampling cycle	open-collector output, switches relative to positive voltage logic "0": transistor is inhibited (max. permissible voltage across switching transistor 30V, max. leakage current 0.1 mA) logic "1": transistor is switched on (max. voltage across switching transistor 1.6V, max. current 50 mA) at least 1sec (1Hz)

Outputs

1 relay (ex-factory)	changeover (SPDT), 3A, 230V AC ¹
6 relays (option)	changeover (SPDT), 3A, 230V AC ^{1,2}

¹ With resistive load. ² It is not permissible to mix SELV circuits and supply circuits.

Interfaces

RS232/RS485 (connector 7) - protocol - baud rate - modem - connector - external inputs	Qty. 1, switchable between RS232 and RS485 Modbus master, Modbus slave and barcode reader 9600, 19200, 38400 can be connected SUB-D via the Modbus master/slave function, 24 analog and 24 binary
RS232 for barcode reader (connector 2) - protocol - baud rate - connector - external inputs	Qty. 1 Modbus master, Modbus slave and barcode reader 9600, 19200, 38400 SUB-D via the Modbus master/slave function, 24 analog and 24 binary
Ethernet (connector 6) - quantity - protocols - baud rate - connector - data format	max. 1 TCP, IP, HTTP, DHCP, SMTP, ModbusTCP 10Mbits/sec, 100Mbits/sec RJ45 HTML
USB host (connector 5) - quantity - use - max. current	2 (or 1 with stainless steel front), connector 5 and front connector (not with stainless steel front); no parallel operation for connecting a memory stick 100mA
USB device (connector 15) - quantity - use	2 (or 1 with stainless steel front), connector 15 and front connector (not with stainless steel front); no parallel operation for connecting to the (master) computer

6 Technical data (extract from data sheet)

Screen

Resolution / size	320 x 240 pixels / 5.5"
Type / number of colors	TFT color screen / 256 colors
Screen refresh rate	> 150Hz
Brightness setting	adjustable on instrument
Screen saver (switch-off)	through waiting time or control signal

Electrical data

Supply voltage (switch-mode PSU)	100 - 240V AC +10/-15%, 48 - 63Hz or 20 - 30V AC/DC, 48 - 63Hz (ELV)
Electrical safety	to EN 61 010, Part 1, August 2002 overvoltage category II, pollution degree 2 terminal for PE conductor
Protection class I	
Test voltages (type test)	
- mains supply circuit to meas. circuit	with AC supply: 2.3kV/50Hz, 1 min, with AC/DC supply: 2.3kV/50Hz, 1 min
- mains supply circuit to housing (protective conductor)	with AC supply: 2.3kV/50Hz, 1 min, with AC/DC supply: 2.3kV/50Hz, 1 min
- measuring current circuits to meas. current circuit and housing	500V/50Hz, 1 min
- electrical isolation between analog inputs	up to 30V AC and 50V DC
Supply voltage error	< 0.1 % of range span
Power consumption	approx. 40VA
Data backup	CompactFlash memory card
Electrical connection	
- mains supply and relays	at rear through pluggable screw terminals, 5.08mm raster, max. conductor cross-section $\leq 2.5\text{mm}^2$ or $2 \times 1.5\text{mm}^2$ with ferrules
- analog and binary inputs	at rear through pluggable screw terminals, 3.81 mm raster, max. conductor cross-section $\leq 1.5\text{mm}^2$

Environmental influences

Ambient temperature range	0 to +50 °C
Ambient temperature effect	0.03 %/°C
Storage temperature range	-20 to +60 °C
Climatic conditions	$\leq 75\%$ relative humidity, no condensation
EMC	EN 61 326-1
- interference emission	Class A - only for industrial use -
- immunity to interference	to industrial requirements

Housing

Housing front	zinc die-casting, optionally in stainless steel (extra code)
Housing type	housing for flush-panel mounting to IEC 61 554, in stainless steel
Bezel size	144 mm x 144 mm to IEC 61 554
Depth behind panel	193 mm (incl. terminals)
Panel cut-out	$138^{+1.0}\text{mm} \times 138^{+1.0}\text{mm}$ to IEC 61 554
Panel thickness	2 - 40 mm
Housing mounting	in panel to DIN 43 834
Operating position	unrestricted, but taking into account the viewing angle of the screen, horizontally $\pm 65^\circ$, vertically $+40^\circ$ to -65°
Enclosure protection	to EN 60 529 Category 2, front IP65, rear IP20
Weight	approx. 3.5 kg

Approvals/marks of conformity

Mark of conformity	Testing laboratory	Certificates / certification numbers	Test basis	valid for
c UL us	Underwriters Laboratories	E 201387	UL 61010-1 CAN/CSA-C22.2 No. 61010-1	the flush-mounted instrument; not in conjunction with extra code 350
II 2G Ex px IIC II 2D Ex pD 21 IP65	electrosuisse	SEV 08 ATEX 0155 U	EN 1127-1:2007 EN 60079-0:2006 EN 60079-2:2007 EN 61241-0:2006 EN 61241-4:2006	the flush-mounted instrument; only in conjunction with extra code 444 and without extra code 350

A

Accessories *11*

B

Back panel *18*

C

Climatic conditions *13*
Commissioning *5*
CompactFlash *7*
Connection diagram *18*

D

Documentation, arrangement of *6*

E

Electrical connection *15*
Electrostatic discharge (ESD) *5*

F

Functional test *27*

I

Installation *13*
Installation notes *15*
Installation site *13*
Instrument documentation in printed form *6*
Instrument documentation in the form of PDF files *6*
Instrument version, identification of *9*
Introduction *5*

M

Mounting *13*

N

Note signs *8*

7 Glossary

P

Panel mounting *14*

R

Returning *5*

S

Standard accessories *11*

Start-up screen *27*

T

Technical data *29*

Type designation *10*

Typographical conventions *8*

V

Views *13*

Visualization level *27*

W

Warning signs *8*

Warranty *5*



JUMO GmbH & Co. KG

Street address:
Moritz-Juchheim-Straße 1
36039 Fulda, Germany
Delivery address:
Mackenrodtstraße 14
36039 Fulda, Germany
Postal address:
36035 Fulda, Germany
Phone: +49 661 6003-0
Fax: +49 661 6003-607
e-mail: mail@jumo.net
Internet: www.jumo.net

JUMO Instrument Co. Ltd.

JUMO House
Temple Bank, Riverway
Harlow, Essex CM20 2DY, UK
Phone: +44 1279 635533
Fax: +44 1279 635262
e-mail: sales@jumo.co.uk
Internet: www.jumo.co.uk

JUMO Process Control, Inc.

8 Technology Boulevard
Canastota, NY 13032, USA
Phone: 315-697-JUMO
1-800-554-JUMO
Fax: 315-697-5867
e-mail: info@jumo.us
Internet: www.jumo.us