

JUMO LOGOSCREEN nt

Paperless Recorder with TFT display
and stainless steel front

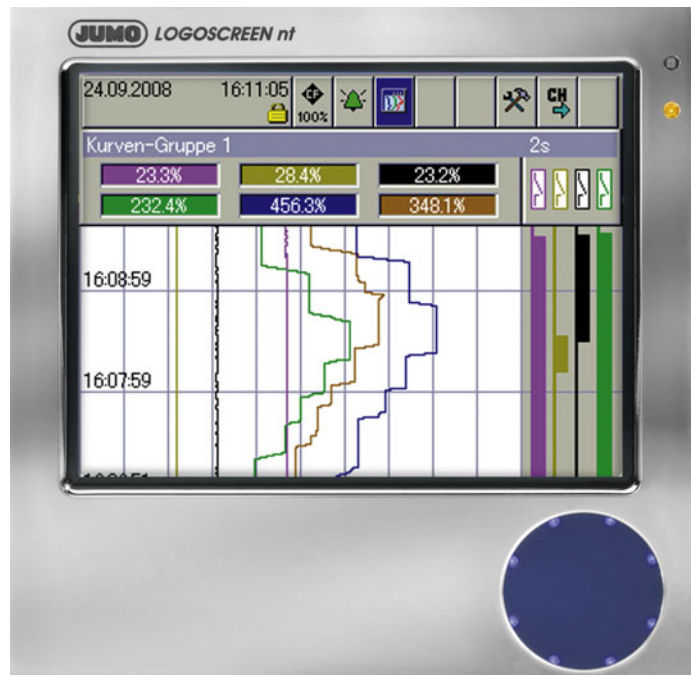

B 706581.4.1 Installation Instructions



The installation instructions describe paperless recorders that are equipped with extra code 443 (NEMA 4X) and 444 (Ex).



The protection type according to NEMA 4X is only achieved if a paperless recorder with stainless steel front is used, if that paperless recorder is equipped with extra code 443 (special seal), and if that paperless recorder is properly mounted along with the seal.

Contents

1	Introduction	5
1.1	Preface	5
1.2	Intended use	6
1.3	Notes on safe use	6
1.4	Arrangement of the documentation	7
1.5	Typographical conventions	9
2	Identifying the device version	11
2.1	Nameplate	11
2.2	Order details	12
2.3	Standard accessories	13
2.4	Accessories	13
3	Installation	15
3.1	Installation site and climatic conditions	15
3.2	Dimensions	15
3.3	Mounting in a panel (extra code 443)	16
3.4	Mounting in a panel (extra code 444)	18
4	Electrical connection	21
4.1	Installation notes	21
4.2	Procedure	23
4.3	Overview of the electrical isolation	25
4.4	Connection diagram	26
4.5	Connection examples concerning binary inputs/outputs	32
5	Functional test	35
6	Technical data	37
6.1	Analog inputs	37

Contents

6.2	Binary inputs/outputs (option)	40
6.3	Outputs	40
6.4	Interfaces	40
6.5	Screen	41
6.6	Electrical data	41
6.7	Environmental influences	42
6.8	Housing	42
6.9	Approvals/marks of conformity	43
7	Declaration of Conformity	45
8	Type Examination Certificate	51
9	China RoHS	55
10	Index	57

1.1 Preface



Please read these installation instructions before commissioning the device. Keep the manual in a place that is accessible to all users at all times.

Please assist us to improve these installation instructions, where necessary.

Your comments will be appreciated.



If any difficulties should arise during commissioning, you are asked not to carry out any manipulations that could endanger your rights under the device warranty!

Please contact the nearest subsidiary or the head office in such a case.



When returning modules, assemblies or components, the regulations of EN 61340-5-1 and EN 61340-5-2 “Protection of electronic devices from electrostatic phenomena” must be observed. Use only the appropriate **ESD** packaging for transport.

Please note that we cannot accept any liability for damage caused by ESD.

ESD=electrostatic discharge

1 Introduction

1.2 Intended use

The device described in these instructions is intended for recording and displaying physical measurement variables in an industrial environment, as specified in the technical data. The device is suitable for installation in switch cabinets with at least a simplified pressurized enclosure. Under these conditions, use in a potentially explosive atmosphere (max. Zones 1 or 21) is authorized from the front.

Any other use or use that goes beyond that described here - with regard to operation in potentially explosive atmospheres - is regarded as not for the intended purpose.

No liability can be accepted for any damage that may result.

The device is constructed in accordance with current standards and directives and complies with existing safety regulations. Nevertheless, improper use may still cause physical injury or damage to property.

To avoid danger, the device must only be used:

- for its intended purpose
- in a perfectly safe conditions
- in compliance with these installation instructions

1.3 Notes on safe use

- When installing a paperless recorder with extra code 443 or 444 in switch cabinets of protection type "px" or "pz" or "py", you must ensure that:
 - the maximum permissible temperature specifications are not exceeded and
 - protection rating IP65, as per the IEC/EN 60529 standard, is achieved (seal mounting).
- In accordance with the ATEX directive Annex I, the paperless recorder with extra code 443 or 444 is a component (Ex component) of equipment group II, category 2G. A separate conformity assessment procedure must be performed for installing these components. Requirements under EN 60079-14 must subsequently be followed for application and installation.
- In accordance with the ATEX directive Annex I, the paperless recorder with extra code 443 or 444 is also a component (Ex component) of equipment group II, category 2D. A separate conformity assessment procedure must be performed for installing these components. Requirements under EN 60079-14 must subsequently be followed for application and installation.
- The permissible (internal and external) ambient temperature range is 0 to +50 °C.
- Under error conditions, the maximum external temperature reached at the front of the paperless recorder with extra code 443 or 444, is 69 °C.

- Batteries are located inside this enclosure. Do not open when an explosive atmosphere is present.
- This pressurized enclosure contains a battery which remains connected after the external power has been isolated. The removal of the battery should be considered if the housing will be unprotected by Ex "p" for a significant amount of time.

1.4 Arrangement of the documentation

The documentation for this device is addressed to equipment manufacturers (OEMs) and users with appropriate technical expertise. It consists of the following parts:

Device documentation in printed form

B 706581.1 Operating Instructions

The operating instructions are an extract from the operating manual and cover the basic operation of the paperless recorder.

B 706581.4(.1) Installation Instructions

The installation instructions describe the installation of the recorder and the connection of the supply and signal cables. The instructions also contain a list of the technical data.

B 706581.4 Installation instructions for recorders with die-cast zinc front

B 706581.4.1 Installation instructions for recorders with stainless steel front

Device documentation in the form of PDF files

The "Device documentation in the form of PDF files" is on the CD that is included in the delivery.

B 706581.0 Operating Manual

It contains information about commissioning, operation, parameterization and configuration on the device.

B 706581.1 Operating Instructions

The operating instructions are an extract from the operating manual and cover the basic operation of the paperless recorder.

B 706581.2.0 Interface Description (serial interfaces)

This provides information on the communication (RS232/RS485) with supervisory systems.

Interface Description (Ethernet interface)

This provides information on the connection of a paperless recorder to a company-internal network. This description is integrated into B 706581.2.0.

1 Introduction

B 706581.2.3 Interface Description (PROFIBUS-DP interface)

This provides information on the connection of a paperless recorder to a PROFIBUS-DP system.

B 706581.4(.1) Installation Instructions

The installation instructions describe the installation of the recorder and the connection of the supply and signal cables. The instructions also contain a list of the technical data.

B 706581.4 Installation instructions for recorders with die-cast zinc front

B 706581.4.1 Installation instructions for recorders with stainless steel front

B 706581.6 Setup Program

The manual describes the function of the setup program. The setup program is available as an option.

T 706581 Data Sheet

The data sheet contains general information, the order details and the technical data.

B 709701.0 PC Evaluation software PCA3000

The operating manual describes the operation and the features of the PC evaluation software.

PCA3000 serves to visualize and evaluate process data (measurement data, batch data, messages, ...). The process data can be read in via the CompactFlash memory card, or made available through the PCC software.

B 709702.0 PCA Communications software PCC

The operating manual describes the operation and the features of the PCA Communications software.

PCC is responsible for the data transfer from the recorder to a PC, or to a network.

Internet



All documents are available for downloading at www.jumo.net

1.5 Typographical conventions

Warning signs

The signs for **Danger** and **Caution** are used in this manual under the following conditions:



Danger

This symbol is used when there may be **danger to personnel** if the instructions are ignored or not followed correctly!



Caution

This symbol is used when there may be **damage to equipment or data** if the instructions are ignored or not followed correctly!



Caution

This symbol is used where special care is required when handling **components liable to damage through electrostatic discharge**.

Note signs



Note

This symbol is used when your **special attention** is drawn to a remark.



Reference

This symbol refers to **further information** in other manuals, chapters or sections.



Action instruction

This symbol indicates that an **action to be performed** is described.

The individual steps are marked by this asterisk, e.g.

- * Move your finger on the touchpad clockwise
- * Press touchpad in the middle



Disposal

At the end of its service life, the device and any batteries present do not belong in the trash! Please ensure that they are disposed of properly and in an environmentally friendly manner.

1 Introduction

2 Identifying the device version

2.1 Nameplate

Position The nameplate is glued onto the paperless recorder.

Illustration The following illustration shows a typical nameplate:

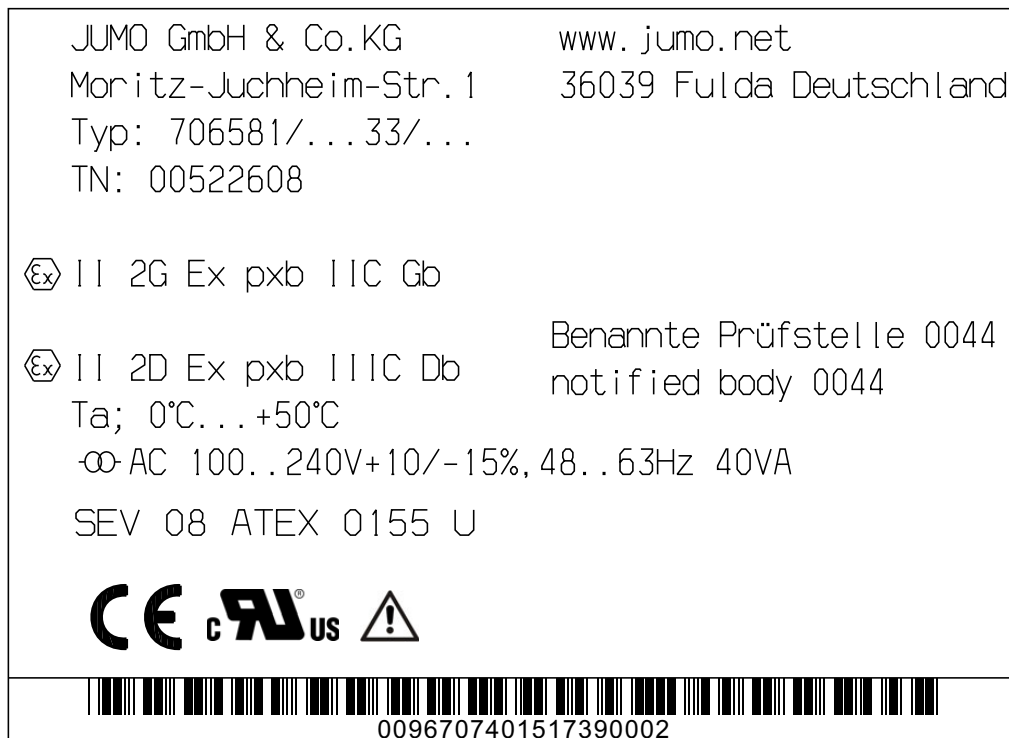

Contents It contains important information, such as:

Description	Designation on the nameplate	Example
Device type	Typ	706581/18-321-33/020,444
Part number	TN	00522608
Supply voltage		AC 100 – 240V +10/-15%, 48 – 63Hz
Serial number		0096707401517390002

Device type Please check the type supplied against your order document. Refer to Chapter 2.2 “Order details” for identification of the type.

Part number The part number (TN) provides an unambiguous definition of an article from the catalog. It is used in communication between the sales department and the customer.



Serial number The serial number – visible below the barcode – indicates the production date (year/week). The figures concerned are in positions 12, 13, 14, 15.

Example: 00967074015**1739**0002



This shows that the paperless recorder was manufactured in 2017, week 39.

2 Identifying the device version

Ex identification marking Paperless recorders with authorization for potentially explosive atmospheres, carry the following mark on the nameplate.

 II 2G Ex pxb IIC Gb
 II 2D Ex pxb IIIC Db

2.2 Order details

	(1) Basic type
706581	LOGOSCREEN nt with TFT display, Ethernet and USB interfaces
	(2) Basic type extension
0	Without software package
1	With software package (setup program, PCA3000, PCC, USB cable)
	(3) Language / Setup
8	Factory setting (German/English)
9	Set to customer specification
	(4) Module slot 1
0	Not used
2	3 analog inputs and 8 binary inputs/outputs
3	6 analog inputs
	(5) Module slot 2
0	Not used
2	3 analog inputs and 8 binary inputs/outputs
3	6 analog inputs
	(6) Module slot 3
0	Not used
1	6 relay outputs
2	3 analog inputs and 8 binary inputs/outputs
3	6 analog inputs
	(7) Voltage supply
25	AC/DC 20 to 30 V, 48 to 63 Hz
33	AC 100 to 240 V +10/-15 %, 48 to 63 Hz
	(8) Extra codes memory
020	Lithium battery for memory buffering (ex-factory)
021	Storage capacitor (ATEX not possible)
	(9) Extra codes
.	Not used
260	Math and logic module
	(10) Extra codes housing
.	Not used
350	Universal carrying case TG-35 ^a
350, 444	Universal carrying case TG-35 ^a and stainless steel front with touchpad
443	Stainless steel front with touchpad, NEMA 4X and 
444	Stainless steel front with touchpad 
	(11) Extra codes
.	Without extra codes
267	PROFIBUS-DP interface

2 Identifying the device version

879	AMS2750/CQI-9 ^b
-----	----------------------------

^a This extra code is only available in combination with voltage supply AC 100 to 240 V. UL, ATEX and NEMA 4X approvals not applicable. The protection type in the carrying case corresponds to IP20, outside IP20D.

^b For the calibration certificate the channels to be checked are to be defined with the thermocouple type and the desired measuring points.

Order code (1) (2) (3) (4) (5) (6) (7) (8) (9) (10) (11)^a
Order example 706581 / - - / , , ,

^a Multiple entries for position 11 are possible. List extra codes in sequence, separated by commas.

2.3 Standard accessories

- 1 Installation Instructions B 706581.4.1
- 1 Operating Instructions B 706581.1
- 4 mounting brackets
- 1 panel seal
- 1 CD with detailed operating manual and supplementary documentation (see Chapter 1.4 “Arrangement of the documentation”)

2.4 Accessories

- Setup program (incl. USB cable)
- PC Evaluation software PCA3000
- PCA Communications software PCC
- CompactFlash memory cards
- USB memory sticks

2 Identifying the device version

3.1 Installation site and climatic conditions

The installation site should be as free as possible from vibration. Electromagnetic fields, such as those caused by motors, transformers etc. should be avoided as far as possible.

The ambient temperature at the site can be 0 to 50°C, at a relative humidity of $\leq 75\%$, no condensation.

⇒ Chapter 4.1 “Installation notes”

3.2 Dimensions

Recorder with stainless steel front

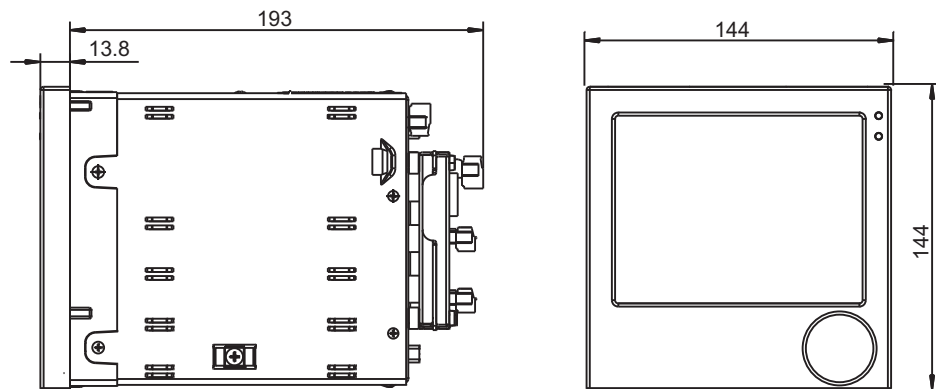

Panel cut-out

It is essential to keep to these dimensions for the panel cut-out. If the panel is less than 2 mm thick, a stiffener must be provided.

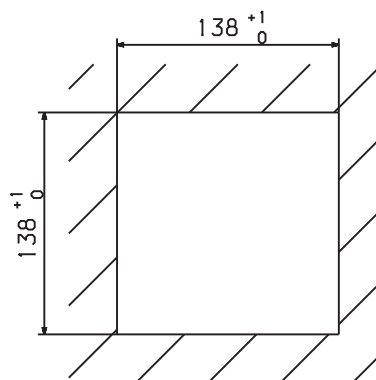

3 Installation

3.3 Mounting in a panel (extra code 443)

- * Fit panel seal.

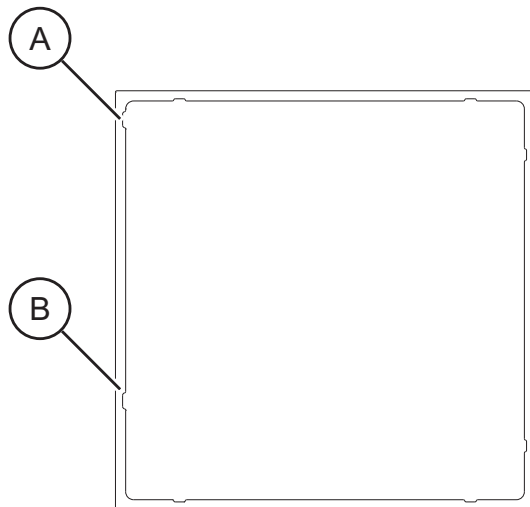
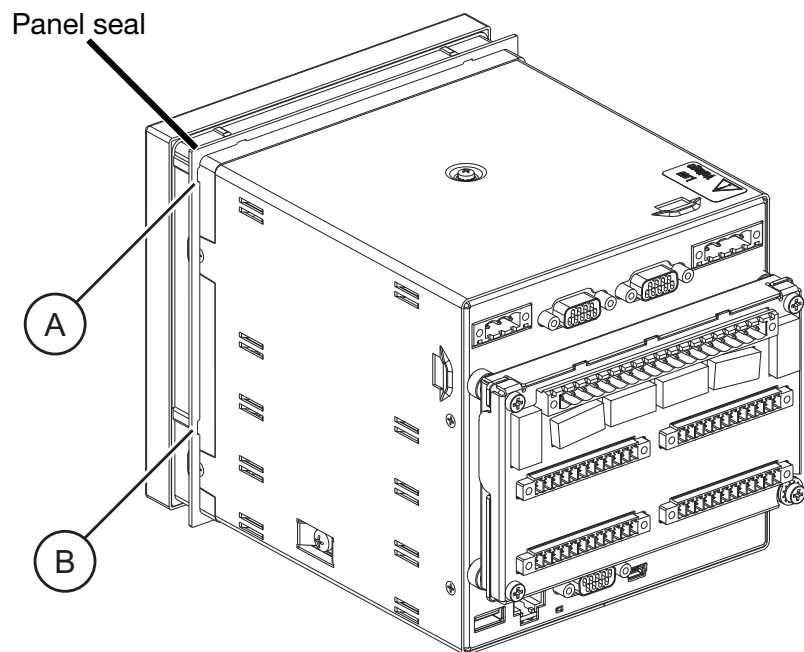

The surface of the panel must be smooth and flat to provide good seating for the panel seal. Check that the seal is evenly and exactly positioned to the front.

- * Insert the paperless recorder from the front into the panel cut-out.

3 Installation

- * From the back of the panel, put the four mounting brackets into the side indentations in the housing and evenly tighten them against the back of the panel at a torque of 50 Ncm.

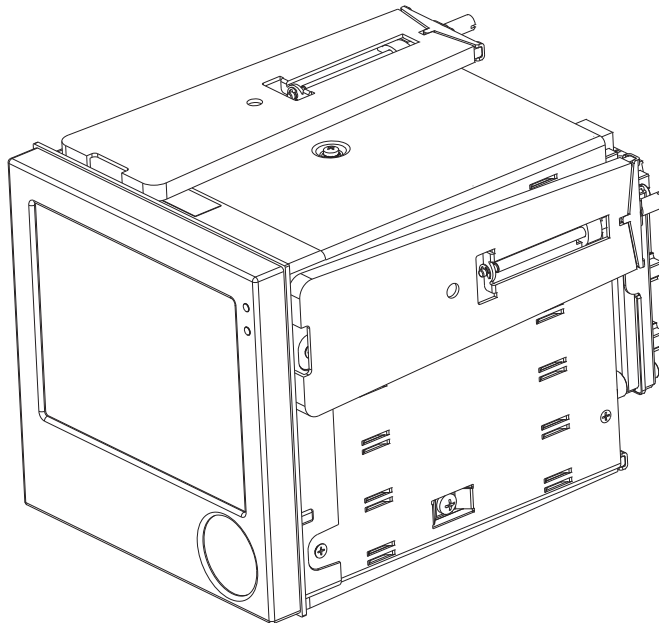

3 Installation

3.4 Mounting in a panel (extra code 444)

- * Fit panel seal (IP65 seal).

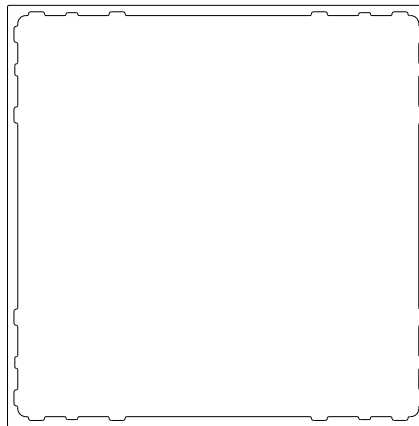
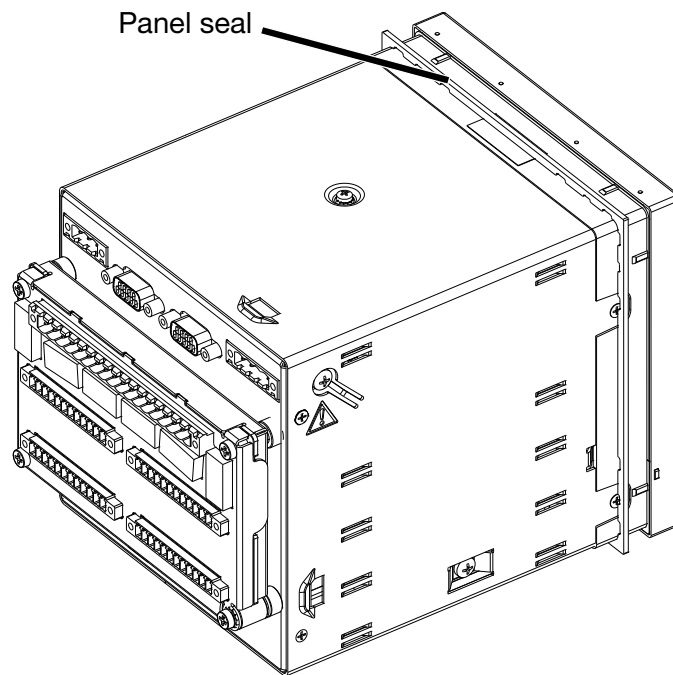

The surface of the panel must be smooth and flat to provide good seating for the panel seal. Check that the seal is evenly and exactly positioned to the front.

- * Insert the paperless recorder from the front into the panel cut-out.

3 Installation

- * From the back of the panel, put the four mounting brackets into the side indentations in the housing and evenly tighten them against the back of the panel at a torque of 50 Ncm.

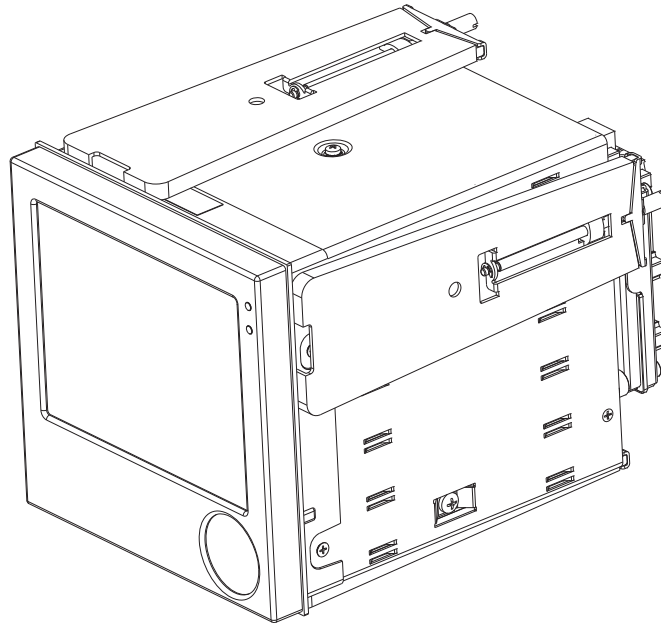

3 Installation

4.1 Installation notes



It is essential to follow the installation notes.

- The device is suitable for installation in switch cabinets with at least a simplified pressurized enclosure. External fuse protection and shut-off must be provided for the device. The fuse must not exceed 20 A.

A device fuse is already built into the device itself (depending on the device design).

20 – 30V AC/DC, 48 – 63Hz : fuse 2.5A slow-blow

100 – 240V AC +10/-15%, 48 – 63Hz : fuse 1.25A slow-blow

- The pressure in the switch cabinet must be at least 0.5 mbar higher than the pressure outside the switch cabinet.
- The choice of cable, the installation and the electrical connection must conform to the requirements of VDE 0100 “Regulations on the Installation of Power Circuits with Nominal Voltages below 1000V” or the appropriate local regulations.
In addition to this, the applicable standards for potentially explosive atmospheres (gas and dust) must be taken into account.
- Suitable isolation (such as a zener barrier or an Ex transmitter) must be provided when signal circuits from a potentially explosive atmosphere are connected to the device.
- Equipment for potentially explosive areas which contain hybrid mixtures has to be especially checked for this use. Hybrid mixtures are potentially explosive mixtures out of combustible gases, vapors, or mists with combustible dust. The operator bears the responsibility of checking if the equipment is suitable for such uses.
- Work inside the device must only be carried out to the extent described and, like the electrical connection, only by qualified personnel.
- For service and repair work, the device must be disconnected from the power supply (all poles) and the atmosphere must be free from the risk of explosion.
- To generate the operating voltage of 20...30 V for Extra Low Voltage (ELV), the maximum nominal voltage of an external power supply must not exceed 240 V (line-to-line and line-to-neutral). If the external nominal voltage is greater than 240 V, an Safety Extra Low Voltage (SELV) power supply must be used. For line-to-line supply of the external power supply, the power supply must have all-pole fuse protection. The fuse must shut off both connections.
- Run input, output and supply cables separately and not parallel to one another.

4 Electrical connection

- In EMC disturbed environments, all input and output cables without connection to the mains supply must be arranged as twisted and screened cables. Earth the screen on the device side to the earth potential.
- Ground the device via the PE terminal of the power supply connector. The cross-section of this cable must be the same as that of the supply cable.
- Do not connect any additional loads to the supply terminals of the device.
- Electromagnetic compatibility (EMC) conforms to the standards and regulations cited in the technical data.
⇒ Chapter 6 “Technical data”
- Inductive loads close to the device, such as contactors or solenoid valves, should have RC modules fitted for interference suppression.

4 Electrical connection

4.2 Procedure

- * Make the electrical connection as per Chapter 4.4 "Connection diagram".
- * Apply strain relief for the connecting cables, if necessary.

Device variant 1

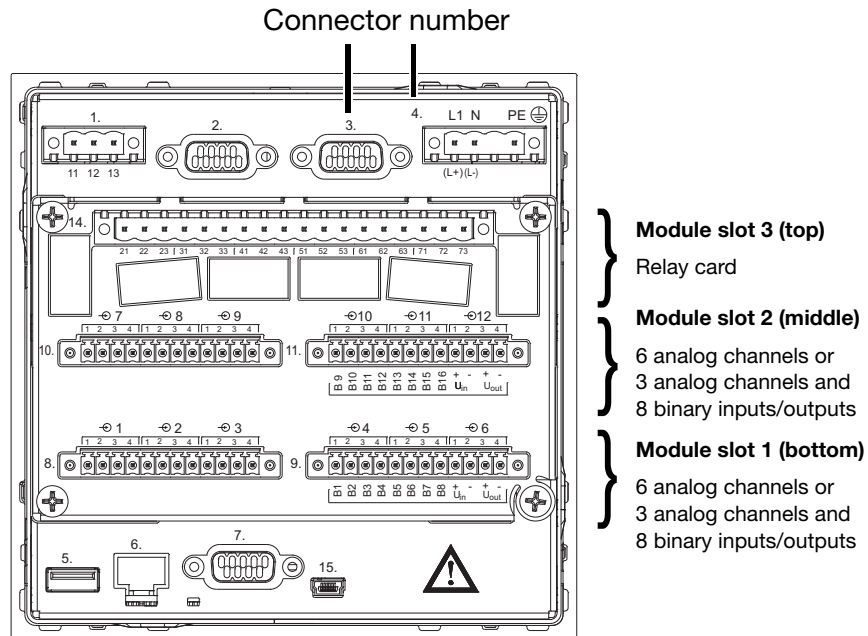

Device variant 2

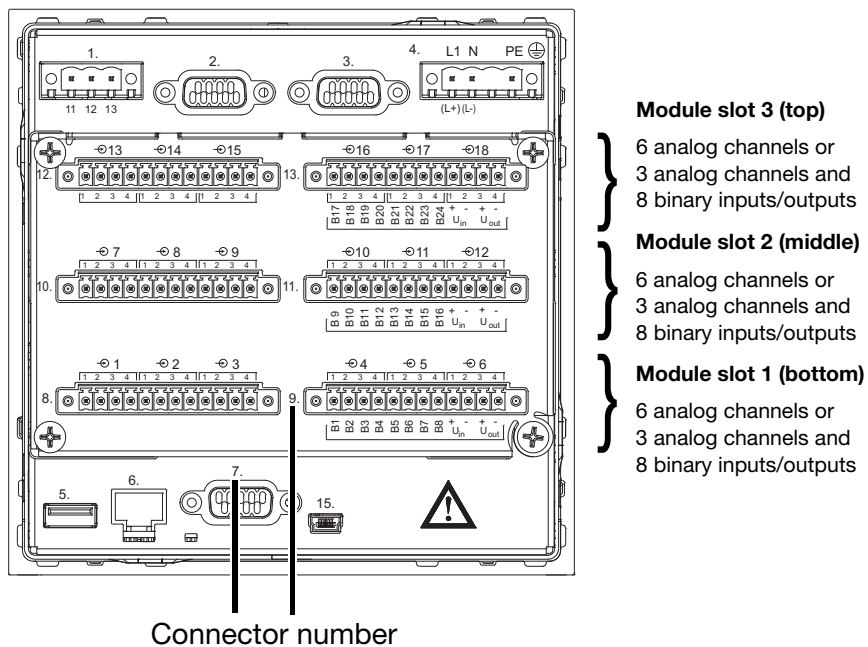

4 Electrical connection

Device variant 3

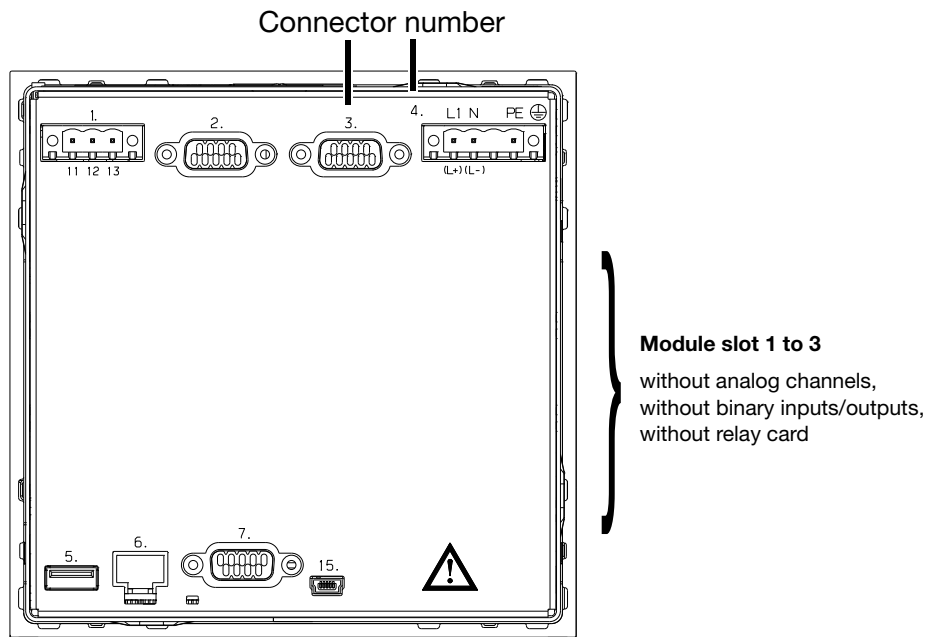

Connector summary

Connector/slot	Function
1	Relay output
2	RS232 for barcode reader
3	PROFIBUS-DP
4	Supply voltage
5	USB host interface
6	Ethernet
7	RS232 and RS485
8	Analog input
9	Analog input or binary inputs/outputs
10	Analog input
11	Analog input or binary inputs/outputs
12	Analog input
13	Analog input or binary inputs/outputs
14	Relay card (for device variant 1)
15	USB device interface

4 Electrical connection

4.3 Overview of the electrical isolation

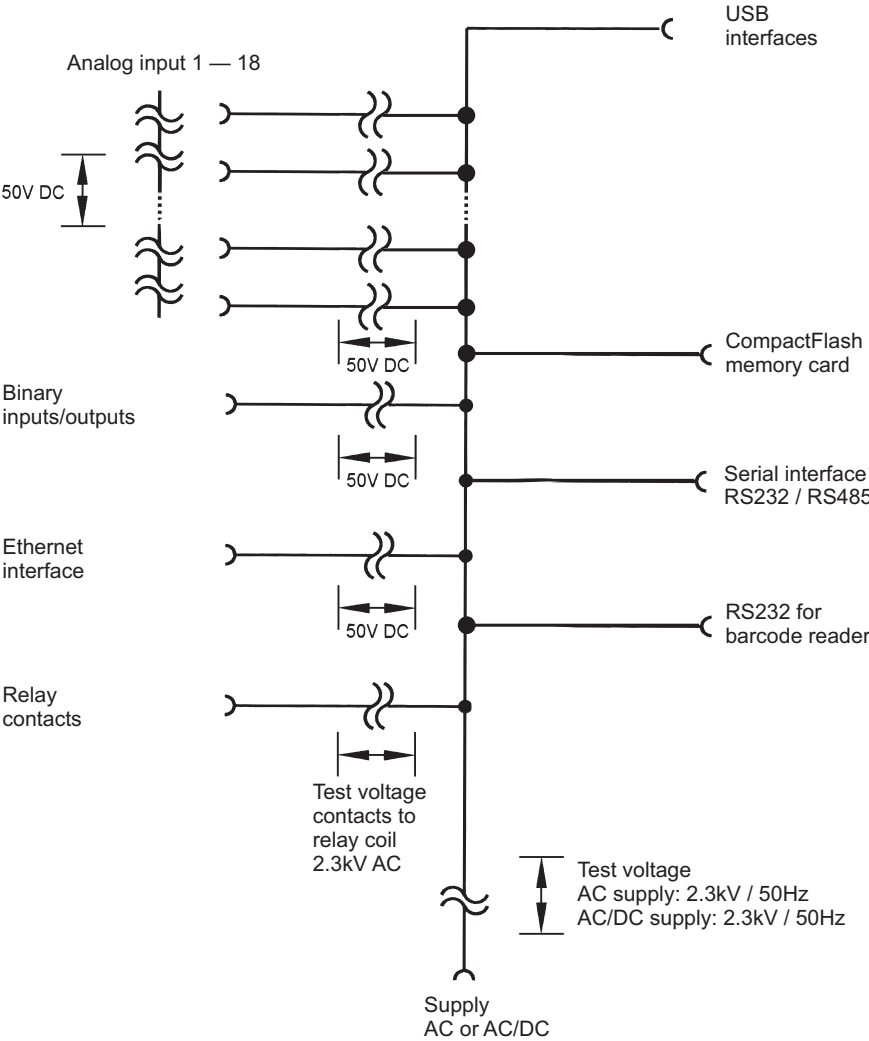

4 Electrical connection

4.4 Connection diagram



The electrical connection must only be carried out by specialist personnel.

Back panel

⇒ Chapter 4.2 “Procedure”

Connections

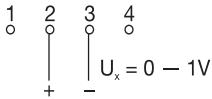
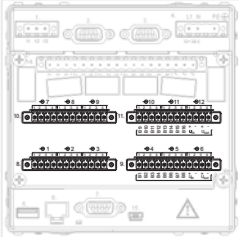
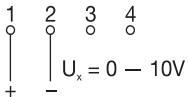
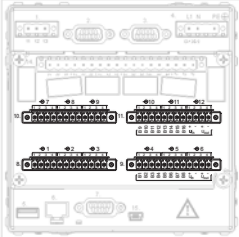
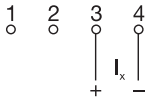
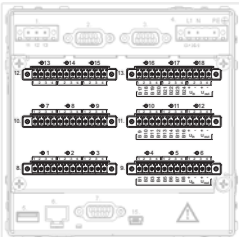

	Terminal assignment	Connector	Diagram
Supply voltage	Supply voltage as on nameplate	Connector 4 L1 (L+) N (L-) PE	
Analog inputs	Thermocouple	Connectors 8 to 11 (input 1 – 12) for device variant 1 or connectors 8 to 13 (input 1 – 18) for device variant 2 	
	RTD temperature probe 2-wire circuit		
	RTD temperature probe 3-wire circuit		
	RTD temperature probe 4-wire circuit		
	Resistance transmitter E = end S = slider A = start		
	Potentiometer in 2-wire circuit		
	Potentiometer in 3-wire circuit		
	Potentiometer in 4-wire circuit		

4 Electrical connection

	Terminal assignment	Connector	Diagram
Analog inputs	Voltage input 0 – 1V	Connectors 8 to 11 (input 1 – 12) for device variant 1	
	Voltage input 0 – 10V		
	Current input		
	<p>or</p> <p>connectors 8 to 13 (input 1 – 18) for device variant 2</p> 		



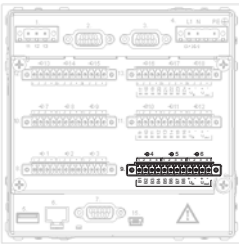
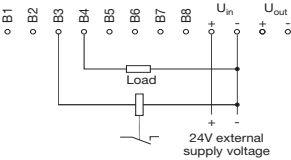
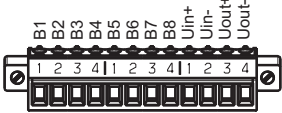
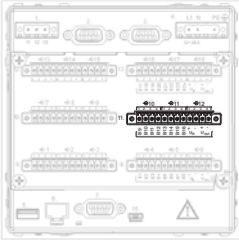

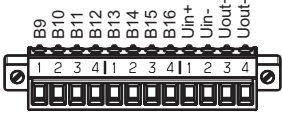
4 Electrical connection

Binary inputs/ outputs

Terminal assignment	Connector	Diagram
 <p>The configuration in the device or in the setup program defines whether it is a binary input or binary output.</p>		
<p>B1 ... B8</p> <p>voltage-controlled LOW = -3 to +5V DC HIGH = 12 to 30V DC</p> <p>B1 Binary input/output 1 B2 Binary input/output 2 B3 Binary input/output 3 B4 Binary input/output 4 B5 Binary input/output 5 B6 Binary input/output 6 B7 Binary input/output 7 B8 Binary input/output 8</p> <p>U_{in+} external supply voltage U_{in-} ground U_{out+} +24V (60mA) internal supply voltage U_{out-} ground</p>	<p>Connector 9 only for modules with 3 analog inputs</p> 	 <p>Example: Connecting a load to binary output 4 (B4) and a solid-state relay to binary output 3 (B3) requires an external supply voltage.</p> <p>Diagram of the connector:</p> 
<p>B9 ... B16</p> <p>voltage-controlled LOW = -3 to +5V DC HIGH = 12 to 30V DC</p> <p>B9 Binary input/output 9 B10 Binary input/output 10 B11 Binary input/output 11 B12 Binary input/output 12 B13 Binary input/output 13 B14 Binary input/output 14 B15 Binary input/output 15 B16 Binary input/output 16</p> <p>U_{in+} external supply voltage U_{in-} ground U_{out+} +24V (60mA) internal supply voltage U_{out-} ground</p>	<p>Connector 11 only for modules with 3 analog inputs</p> 	 <p>Example: Binary input 12 (B12) is operated from the internal supply voltage.</p> <p>Diagram of the connector:</p> 

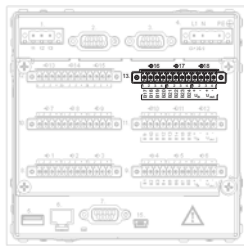

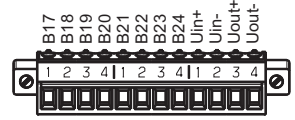

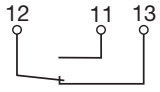
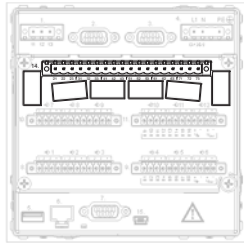
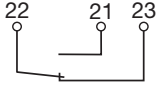
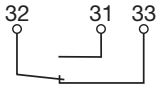
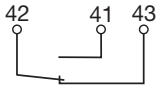
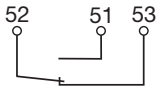
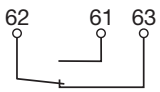
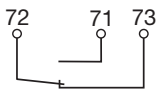

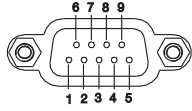

4 Electrical connection

Binary inputs/ outputs

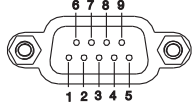

Terminal assignment	Connector	Diagram
<p>B17 ... B24</p> <p>voltage-controlled LOW = -3 to +5V DC HIGH = 12 to 30V DC</p> <p>B17 Binary input/output 17 B18 Binary input/output 18 B19 Binary input/output 19 B20 Binary input/output 20 B21 Binary input/output 21 B22 Binary input/output 22 B23 Binary input/output 23 B24 Binary input/output 24</p> <p>U_{in+} external supply voltage U_{in-} ground U_{out+} +24V (60mA) internal supply voltage U_{out-} ground</p>	<p>Connector 13</p> <p>only for device variant 2 and on modules with 3 analog inputs</p> 	 <p>Example: Binary input 20 (B20) is operated from the internal supply voltage.</p> <p>Diagram of the connector:</p> 
<p>Relay 1 - alarm changeover (SPDT)</p>	<p>Connector 1</p> 	
<p>Relay 2 changeover (SPDT)</p>	<p>Connector 14</p> <p>only for device variant 1</p> 	
<p>Relay 3 changeover (SPDT)</p>		
<p>Relay 4 changeover (SPDT)</p>		
<p>Relay 5 changeover (SPDT)</p>		
<p>Relay 6 changeover (SPDT)</p>		
<p>Relay 7 changeover (SPDT)</p>		

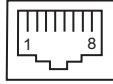
Relay outputs

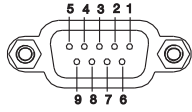
4 Electrical connection

Terminal assignment	Connector	Diagram
Interfaces RS232C for barcode reader 9-pin SUB-D socket connector 2 RxD receive data 3 TxD transmit data 5 GND ground	Connector 2 	
PROFIBUS-DP 9-pin SUB-D socket connector (extra code) 3 RxD/TxD-P B conductor Receive/transmit data positive 5 DGND Data transmission ground 6 VP voltage supply positive 8 RxD/TxD-N A conductor Receive/transmit data negative	Connector 3 	
USB host interface for memory sticks The recorder without stainless steel front also has a USB host interface on the front panel, connected in parallel. The two interfaces cannot both be operated at the same time.	Connector 5 	
Ethernet RJ45 socket connector 1 TX+ transmit data + 2 TX- transmit data - 3 RX+ receive data + 6 RX+ receive data -	Connector 6 	
RS232C 9-pin SUB-D socket connector (switchable to RS485) 2 RxD receive data 3 TxD transmit data 5 GND ground	Connector 7 	

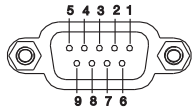
4 Electrical connection

Terminal assignment	Connector	Diagram
<p>RS485 9-pin SUB-D socket connector (switchable to RS232)</p> <p>3 TxD+/RxD+ Transmit/receive data +</p> <p>5 GND ground</p> <p>8 TxD-/RxD- Transmit/receive data -</p>	<p>Connector 7</p> 	
<p>USB device interface for connecting a PC</p> <p>The recorder without stainless steel front also has a USB device interface on the front panel, connected in parallel. The two interfaces cannot both be operated at the same time.</p>	<p>Connector 15</p> 	

4 Electrical connection

4.5 Connection examples concerning binary inputs/outputs

Binary inputs Triggering via external relays and external supply voltage:

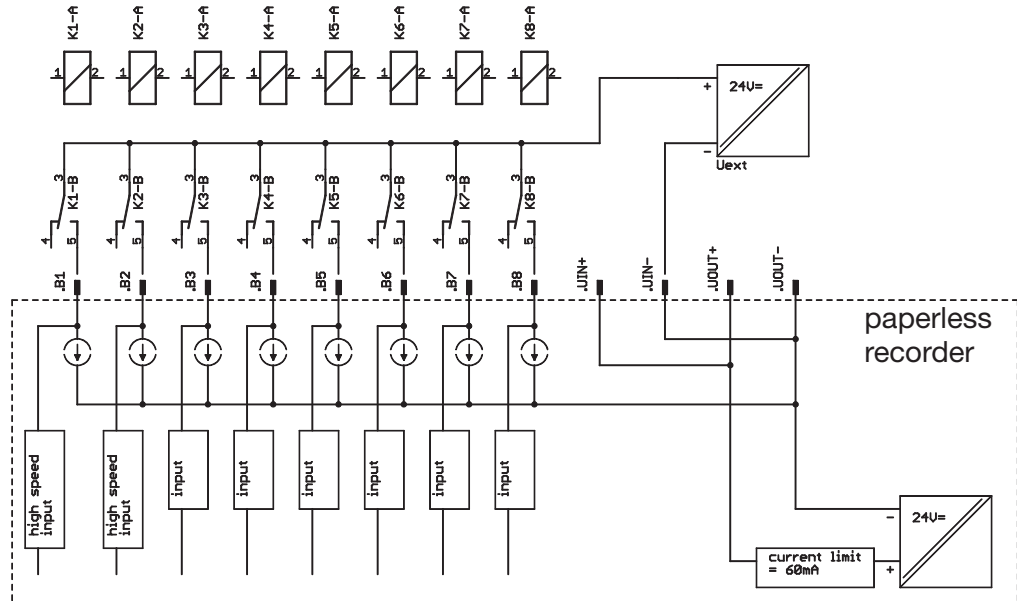

Triggering via external relays and internal supply voltage:

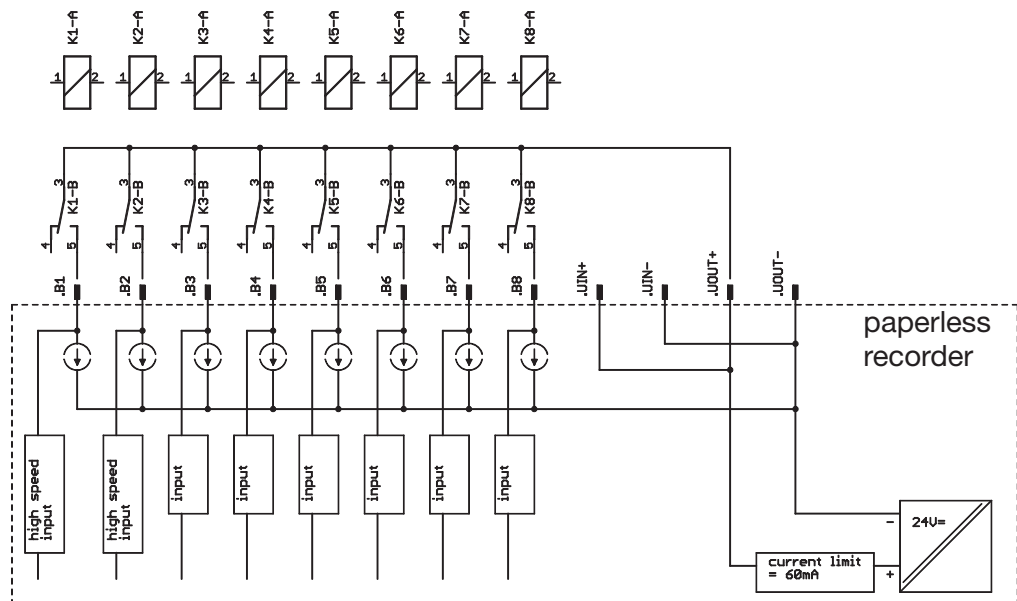

4 Electrical connection

Triggering via external opto-coupler and internal supply voltage:

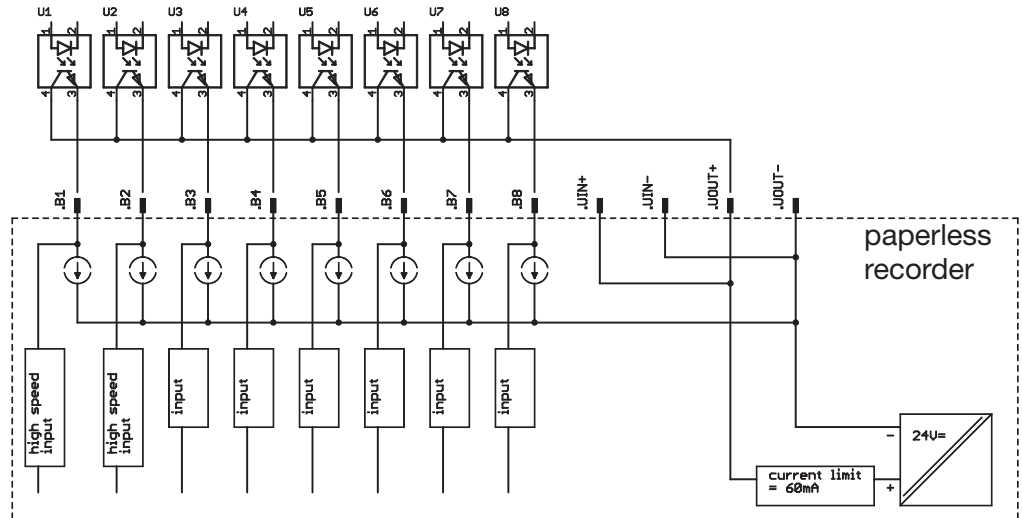

Triggering via external switches (potential-free) and internal supply voltage:

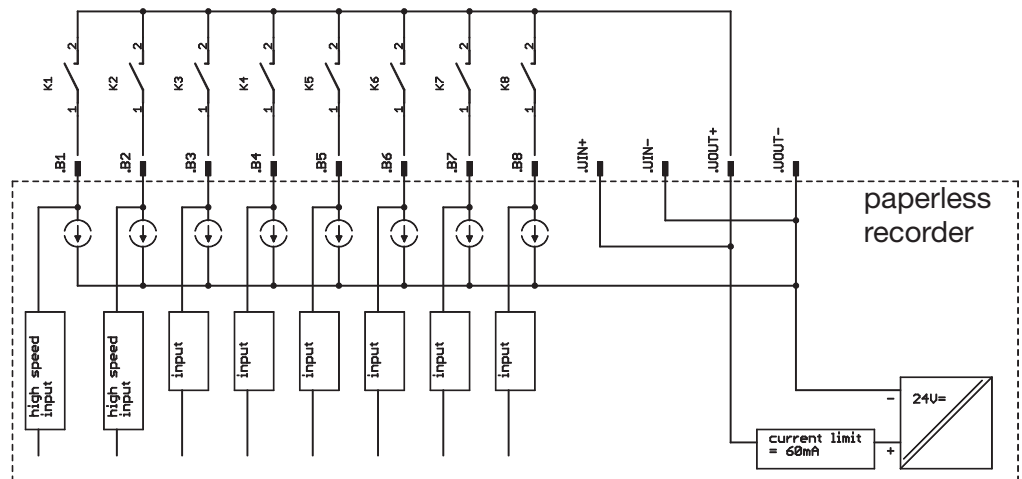

4 Electrical connection

Binary outputs

Triggering of external relays via external supply voltage:

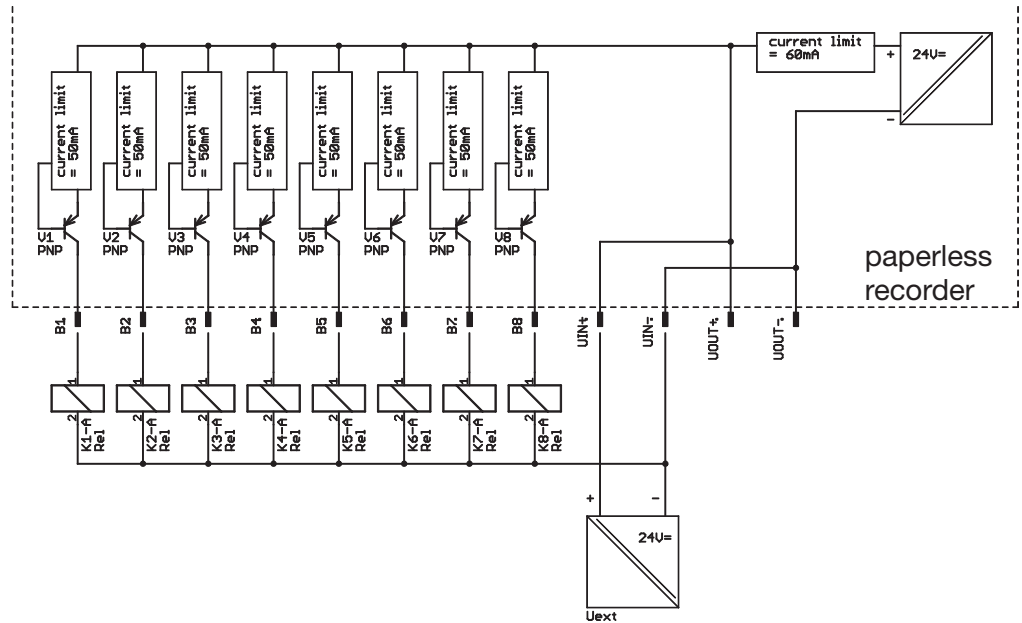

Triggering of external relays via internal supply voltage:

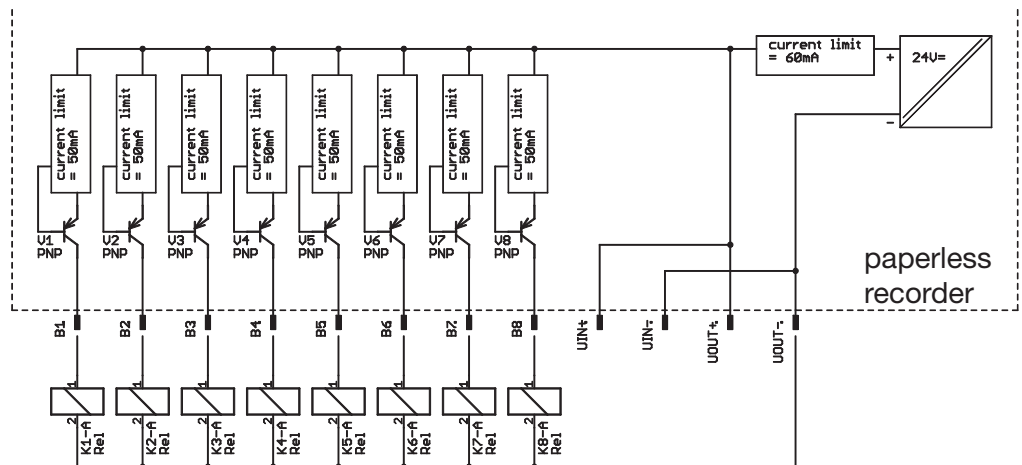

By triggering the external relays via the internal supply voltage the total current must not exceed 60mA.

5 Functional test



Prior to each switch on of the voltage supply the user must ensure that no flammable dust accumulation has entered the interior of the paperless recorder.

After the paperless recorder has been installed and wired up, it can be commissioned. After applying or switching on the voltage supply, the start-up screen will appear for a short time.

Start-up screen



The visualization will start automatically after the initialization phase.

Visualization

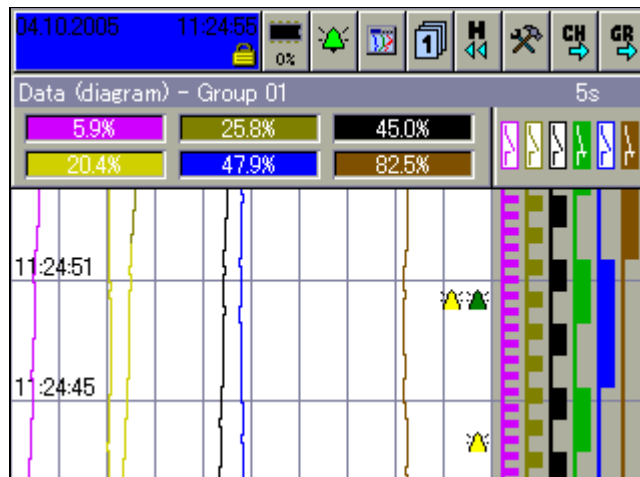

The paperless recorder is now in the recording phase.

5 Functional test

Further steps



The recorder can be configured by an authorized person, either by using the touchpad (turn and touch with one finger) or with the help of the PC setup program.

Further information about configuration can be found in the operating manual B 706581.0.

Finally, make another check that the connection, configuration and function of the recorder are all correct.

6.1 Analog inputs

Thermocouple

Designation	Measuring range	Accuracy ^a
Fe-CuNi L DIN 43710	-200 to +900 °C	±0.1 %
Fe-CuNi J EN 60584	-200 to +1200 °C	±0.1 % from -100 °C
Cu-CuNi U DIN 43710	-200 to +600 °C	±0.1 % from -150 °C
Cu-CuNi T EN 60584	-270 to +400 °C	±0.1 % from -150 °C
NiCr-Ni K EN 60584	-200 to +1372 °C	±0.1 % from -80 °C
NiCr-CuNi E EN 60584	-200 to +1000 °C	±0.1 % from -80 °C
NiCrSi-NiSi N EN 60584	-100 to +1300 °C	±0.1 % from -80 °C
Pt10Rh-Pt S EN 60584	0 to 1768 °C	±0.15 %
Pt13Rh-Pt R EN 60584	0 to 1768 °C	±0.15 %
Pt30Rh-Pt6Rh B EN 60584	0 to 1820 °C	±0.15 % from 400 °C
W3Re/W25Re D	0 to 2495 °C	±0.15 % from 500 °C
W5Re/W26Re C	0 to 2320 °C	±0.15 % from 500 °C
W3Re/W26Re	0 to 2400 °C	±0.15 % from 500 °C
Chromel-copel GOST R 8.585-2001	-200 to +800 °C	±0.15 % from -80 °C
Chromel-alumel GOST R 8.585-2001 PLII (Platinel II)	-200 to +1372 °C 0 to 1395 °C	±0.1 % from -80 °C ±0.15 %
Shortest span	Type L, J, U, T, K, E, N, chromel-alumel, PLII: 100 °C Type S, R, B, D, C, W3Re/W26Re, chromel-copel: 500 °C	
Range start/end	freely programmable within the limits, in 0.1 °C steps	
Cold junction	Pt100 internal or thermostat external constant	
Cold junction accuracy (internal)	±1 °C	
Cold junction temperature (external)	-50 to +150 °C adjustable	
Sampling cycle	Channel 1 to 18: 125 ms in total	
Input filter	2nd order digital filter; filter constant adjustable from 0 to 10.0 sec	
Electrical isolation	see "Electrical data" on page 41 and "Overview of the electrical isolation" on page 25	
Resolution	dynamic resolution up to 16 bit	
Features	also programmable in °F	

^a The linearization accuracy refers to the maximum measuring range. The linearization accuracy is reduced with short spans.

RTD temperature probe

Designation	Connection circuit	Measuring range	Accuracy ^a	Measurement current
Pt100 EN 60751 (TC = $3.85 \cdot 10^{-3} \text{ 1/}^\circ\text{C}$)	2-/3-wire	-200 to +100 °C	±0.5 °C	≈ 250 μA
	2-/3-wire	-200 to +850 °C	±0.8 °C	≈ 250 μA
	4-wire	-200 to +850 °C	±0.5 °C	≈ 250 μA
Pt100 JIS 1604 (TC = $3.917 \cdot 10^{-3} \text{ 1/}^\circ\text{C}$)	2-/3-wire	-200 to +100 °C	±0.5 °C	≈ 250 μA
	2-/3-wire	-200 to +650 °C	±0.8 °C	≈ 250 μA
	4-wire	-200 to +650 °C	±0.5 °C	≈ 250 μA
Pt100 GOST 6651-94 A.1 (TC = $3.91 \cdot 10^{-3} \text{ 1/}^\circ\text{C}$)	2-/3-wire, 4-wire	-200 to +100 °C	±0.5 °C	≈ 250 μA
	2-/3-wire, 4-wire	-200 to +850 °C	±0.8 °C	≈ 250 μA
Pt500 EN 60751 (TC = $3.85 \cdot 10^{-3} \text{ 1/}^\circ\text{C}$)	2-/3-wire, 4-wire	-200 to +100 °C	±0.5 °C	≈ 100 μA
	2-/3-wire, 4-wire	-200 to +850 °C	±0.9 °C	≈ 100 μA
Pt1000 EN 60751 (TC = $3.85 \cdot 10^{-3} \text{ 1/}^\circ\text{C}$)	2-/3-wire	-200 to +100 °C	±0.5 °C	≈ 100 μA
	2-/3-wire	-200 to +850 °C	±0.8 °C	≈ 100 μA
	4-wire	-200 to +850 °C	±0.5 °C	≈ 100 μA

6 Technical data

Designation	Connection circuit	Measuring range	Accuracy ^a	Measurement current
Ni100 DIN 43760 (TC = $6.18 \cdot 10^{-3} \text{ 1/}^\circ\text{C}$)	2-/3-wire, 4-wire	-60 to +180 °C	$\pm 0.4 \text{ }^\circ\text{C}$	$\approx 250 \text{ }\mu\text{A}$
Pt50 ST RGW 1057 1985 (TC = $3.91 \cdot 10^{-3} \text{ 1/}^\circ\text{C}$)	2-/3-wire	-200 to +100 °C	$\pm 0.5 \text{ }^\circ\text{C}$	$\approx 250 \text{ }\mu\text{A}$
	2-/3-wire	-200 to +1100 °C	$\pm 0.9 \text{ }^\circ\text{C}$	$\approx 250 \text{ }\mu\text{A}$
	4-wire	-200 to +100 °C	$\pm 0.5 \text{ }^\circ\text{C}$	$\approx 250 \text{ }\mu\text{A}$
	4-wire	-200 to +1100 °C	$\pm 0.6 \text{ }^\circ\text{C}$	$\approx 250 \text{ }\mu\text{A}$
Cu50 (TC = $4.26 \cdot 10^{-3} \text{ 1/}^\circ\text{C}$)	2-/3-wire	-50 to +100 °C	$\pm 0.5 \text{ }^\circ\text{C}$	$\approx 250 \text{ }\mu\text{A}$
	2-/3-wire	-50 to +200 °C	$\pm 0.9 \text{ }^\circ\text{C}$	$\approx 250 \text{ }\mu\text{A}$
	4-wire	-50 to +100 °C	$\pm 0.5 \text{ }^\circ\text{C}$	$\approx 250 \text{ }\mu\text{A}$
	4-wire	-50 to +200 °C	$\pm 0.7 \text{ }^\circ\text{C}$	$\approx 250 \text{ }\mu\text{A}$
Cu100 GOST 6651-94 A.4 (TC = $4.26 \cdot 10^{-3} \text{ 1/}^\circ\text{C}$)	2-/3-wire	-50 to +100 °C	$\pm 0.5 \text{ }^\circ\text{C}$	$\approx 250 \text{ }\mu\text{A}$
	2-/3-wire	-50 to +200 °C	$\pm 0.9 \text{ }^\circ\text{C}$	$\approx 250 \text{ }\mu\text{A}$
	4-wire	-50 to +100 °C	$\pm 0.5 \text{ }^\circ\text{C}$	$\approx 250 \text{ }\mu\text{A}$
	4-wire	-50 to +200 °C	$\pm 0.6 \text{ }^\circ\text{C}$	$\approx 250 \text{ }\mu\text{A}$
Connection circuit	2-, 3-, or 4-wire circuit			
Shortest span	15 °C			
Sensor lead resistance	max. 30 per conductor for 3-wire/4-wire circuit max. 10 per conductor for 2-wire circuit			
Range start/end	freely programmable within the limits, in 0.1 °C steps			
Sampling cycle	Channel 1 to 18: 125 ms in total			
Input filter	2nd order digital filter; filter constant adjustable from 0 to 10 sec			
Electrical isolation	see "Electrical data" on page 41 and "Overview of the electrical isolation" on page 25			
Resolution	dynamic resolution up to 16 bit			
Features	also programmable in °F			

^a The linearization accuracy refers to the maximum measuring range. The linearization accuracy is reduced with short spans.

Resistance transmitter and potentiometer

Designation	Measuring range	Accuracy ^a	Measurement current
Resistance transmitter	up to 4000 Ω	$\pm 4 \text{ }\Omega$	$\approx 100 \text{ }\mu\text{A}$
Potentiometer	< 400 Ω	$\pm 400 \text{ m}\Omega$	$\approx 250 \text{ }\mu\text{A}$
	$\geq 400 \text{ }\Omega$ to 4000 Ω	$\pm 4 \text{ }\Omega$	$\approx 100 \text{ }\mu\text{A}$
Connection circuit	resistance transmitter: 3-wire circuit potentiometer: 2-/3-/4-wire circuit		
Shortest span	60 Ω		
Sensor lead resistance	max. 30 per conductor for 4-wire circuit max. 10 per conductor for 2-/3-wire circuit		
Resistance values	freely programmable within the limits, in 0.1 steps		
Sampling cycle	Channel 1 to 18: 125 ms in total		
Input filter	2nd order digital filter; filter constant adjustable from 0 to 10.0 sec		
Electrical isolation	see "Electrical data" on page 41 and "Overview of the electrical isolation" on page 25		
Resolution	dynamic resolution up to 16 bit		

^a The linearization accuracy refers to the maximum measuring range. The linearization accuracy is reduced with short spans.

6 Technical data

Input for DC voltage, DC current

Basic range	Accuracy ^a	Input resistance
-12 to +112 mV	$\pm 100 \mu\text{V}$	$R_E \geq 1 \text{ M}\Omega$
-10 to +210 mV	$\pm 240 \mu\text{V}$	$R_E \geq 470 \text{ k}\Omega$
-1.5 to +11.5 V	$\pm 6 \text{ mV}$	$R_E \geq 470 \text{ k}\Omega$
-0.12 to +1.12 V	$\pm 1 \text{ mV}$	$R_E \geq 470 \text{ k}\Omega$
-1.2 to +1.2 V	$\pm 2 \text{ mV}$	$R_E \geq 470 \text{ k}\Omega$
-11.2 to +11.2 V	$\pm 12 \text{ mV}$	$R_E \geq 470 \text{ k}\Omega$
Shortest span	5 mV	
Range start/end	freely programmable within the limits in 0.01 mV steps	
-1.3 to +22 mA	$\pm 20 \mu\text{A}$	burden voltage $\leq 3 \text{ V}$
-22 to +22 mA	$\pm 44 \mu\text{A}$	burden voltage $\leq 3 \text{ V}$
Shortest span	0.5 mA	
Range start/end	freely programmable within the limits in 0.01 mA steps	
Overrange/underrange	according to NAMUR NE 43	
Sampling cycle	Channel 1 to 18: 125 ms in total	
Input filter	2nd order digital filter; filter constant adjustable from 0 to 10.0 sec	
Electrical isolation	see "Electrical data" on page 41 and "Overview of the electrical isolation" on page 25	
Resolution	dynamic resolution up to 16 bit	

^a The linearization accuracy refers to the maximum measuring range. The linearization accuracy is reduced with short spans.

Transducer short circuit/break

	Short-circuit ^a	Break ^a
Thermocouple	not detected	detected
RTD temperature probe	detected	detected
Resistance transmitter	not detected	detected
Potentiometer	not detected	detected
Voltage $\leq \pm 210 \text{ mV}$	not detected	detected
Voltage $> \pm 210 \text{ mV}$	not detected	not detected
Current	not detected	not detected

^a Programmable reaction of device, e.g. triggering alarm

6 Technical data

6.2 Binary inputs/outputs (option)

Input or output	configurable as input or output
Number	8, 16 or 24, depending on the device version, to DIN VDE 0411, Part 500; max. 25 Hz, max. 32 V
Input <ul style="list-style-type: none"> level counting frequency 	logic "0": -3 to +5 V (input current max. ± 1 mA), logic "1": 12 to 30 V ($2.5 \text{ mA} \leq \text{input current} \leq 5 \text{ mA}$) 8Hz
High-speed input <ul style="list-style-type: none"> task counting frequency 	the first two binary inputs of each module (B1, B2, B9, B10, B17, B18), if the module is not fitted with relays or 6 analog inputs count function, e.g. for flow measurement 10 kHz
Output <ul style="list-style-type: none"> type level sampling cycle 	open-collector output, switches relative to positive voltage logic "0": transistor is inhibited (max. permissible voltage across switching transistor 30 V, max. leakage current 0.1 mA) logic "1": transistor is switched on (max. voltage across switching transistor 1.6 V, max. current 50 mA) at least 1 sec (1 Hz)

6.3 Outputs

1 relay (ex-factory)	changeover (SPDT), 3 A, 230 V AC ^a
6 relays (option)	changeover (SPDT), 3 A, 230 V AC ^{a, b}

^a With resistive load.

^b It is not permissible to mix SELV circuits and supply circuits.

6.4 Interfaces

RS232/RS485 (connector 7) <ul style="list-style-type: none"> protocol baud rate modem connector external inputs 	Qty. 1, switchable between RS232 and RS485 Modbus master, Modbus slave and barcode reader 9600, 19200, 38400 can be connected SUB-D via the Modbus master/slave function, 54 analog and 54 binary
RS232 for barcode reader (connector 2) <ul style="list-style-type: none"> protocol baud rate connector external inputs 	Qty. 1 Modbus master, Modbus slave and barcode reader 9600, 19200, 38400 SUB-D via the Modbus master/slave function, 54 analog and 54 binary
Ethernet (connector 6) <ul style="list-style-type: none"> quantity protocols baud rate connector data format 	max. 1 TCP, IP, HTTP, DHCP, SMTP, ModbusTCP 10 Mbits/sec, 100 Mbits/sec RJ45 HTML

6 Technical data

USB host (connector 5) <ul style="list-style-type: none"> quantity use max. current 	2 (or 1 with stainless steel front), connector 5 and front connector (not with stainless steel front); no parallel operation for connecting a memory stick 100 mA
USB device (connector 15) <ul style="list-style-type: none"> quantity use 	2 (or 1 with stainless steel front), connector 15 and front connector (not with stainless steel front); no parallel operation for connecting to the (master) computer
PROFIBUS-DP (connector 3) <ul style="list-style-type: none"> quantity connector transfer rate external inputs 	max. 1 (extra code) SUB-D max. 12 Mbit/s via Profibus slave function, 54 analog and 54 binary

6.5 Screen

Resolution/size	320 × 240 pixels/5.5"
Type/number of colors	TFT color screen/256 colors
Screen refresh rate	> 150 Hz
Brightness setting	adjustable on device
Screen saver (switch-off)	through waiting time or control signal
Operation <ul style="list-style-type: none"> die-cast zinc front stainless steel front (extra code) 	via control knob via capacitive touchpad Caution: Do not use the touchpad with damp/wet fingers to avoid condensation.

6.6 Electrical data

Supply voltage (switch-mode PSU)	AC 100 to 240V +10/-15%, 48 - 63Hz or AC/DC 20 to 30V, 48 - 63Hz (ELV)
Electrical safety Protection class I Test voltages (type test) <ul style="list-style-type: none"> mains supply circuit to meas. circuit mains supply circuit to housing (protective conductor) measuring current circuits to measuring current circuit and housing electrical isolation between analog inputs 	to DIN EN 61010, Part 1, July 2011 overvoltage category II, pollution degree 2 terminal for PE conductor with AC supply: 2.3 kV/50 Hz, 1 min, with AC/DC supply: 2.3 kV/50 Hz, 1 min with AC supply: 2.3 kV/50 Hz, 1 min, with AC/DC supply: 2.3 kV/50 Hz, 1 min 500 V/50 Hz, 1 min up to 30 V AC and 50 V DC
Supply voltage error	< 0.1 % of range span
Power consumption	approx. 40 VA
Data backup	CompactFlash memory card

6 Technical data

Electrical connection	
<ul style="list-style-type: none">• mains supply and relays• analog and binary inputs	at rear through pluggable screw terminals, 5.08 mm raster, max. conductor cross-section $\leq 2.5 \text{ mm}^2$ or $2 \times 1.5 \text{ mm}^2$ with ferrules at rear through pluggable screw terminals, 3.81 mm raster, max. conductor cross-section $\leq 1.5 \text{ mm}^2$

6.7 Environmental influences

Ambient temperature range	0 to +50 °C
Ambient temperature effect	0.03 %/°C
Storage temperature range	-20 to +60 °C
Climatic conditions	≤ 75 % relative humidity, no condensation
Site altitude	up to 2000 m above sea level
EMC	EN 61326-1
<ul style="list-style-type: none">• interference emission• immunity to interference	Class A - only for industrial use - to industrial requirements

6.8 Housing

Housing front	zinc die-casting, optionally in stainless steel (extra code)
Housing type	housing for flush-panel mounting to IEC 61554, in stainless steel (indoor use)
Bezel size	144 mm \times 144 mm to IEC 61554
Depth behind panel	193 mm (incl. terminals)
Panel cut-out	$138^{+1.0}$ mm \times $138^{+1.0}$ mm to IEC 61554
Panel thickness	2 to 40 mm
Housing mounting	in panel to DIN 43834
Operating position	unrestricted, but taking into account the viewing angle of the screen, horizontally $\pm 65^\circ$, vertically $+40^\circ$ to -65°
Enclosure protection	to EN 60529 Category 2, front IP65, rear IP20
Weight	approx. 3.5 kg

6.9 Approvals/marks of conformity

Mark of conformity	Testing laboratory	Certificates/ certification numbers	Test basis	valid for
c UL us	Underwriters Laboratories	E 201387	UL 61010-1 CAN/CSA- C22.2 No. 61010-1	the flush-mounted device; not in conjunction with extra code 350
II 2G Ex pxb IIC Gb II 2D Ex pxb IIIC Db	Eurofins Electrosuisse	SEV 08 ATEX 0155 U	EN 60079-0:2012 + A11:2013 EN 60079-2:2014	the flush-mounted device; only in conjunction with extra code 443 or 444 and without extra code 350
NEMA 4X	Intertek	4010203	NEMA 250-2008	the flush-mounted device; only in conjunction with extra code 443 and without extra code 350

6 Technical data

7 Declaration of Conformity

JUMO GmbH & Co. KG

Moritz-Juchheim-Straße 1
36039 Fulda, Germany

Tel.: +49 661 6003-0
Fax: +49 661 6003-500

E-Mail: mail@jumo.net
Internet: www.jumo.net



More than sensors + automation

EU-Konformitätserklärung

EU declaration of conformity / Déclaration UE de conformité

Dokument-Nr.

CE 710

Document No. / Document n°.

Hersteller

JUMO GmbH & Co. KG

Manufacturer / Etabli par

Anschrift

Moritz-Juchheim-Straße 1, 36039 Fulda, Germany

Address / Adresse

Produkt

Product / Produit

Name

Name / Nom

Typ

Type / Type

Typenblatt-Nr.

*Data sheet no. / N°
Document
d'identification*

JUMO LOGOSCREEN nt

706581

706581

Wir erklären in alleiniger Verantwortung, dass das bezeichnete Produkt die Anforderungen der Europäischen Richtlinien erfüllt.

We hereby declare in sole responsibility that the designated product fulfills the requirements of the European Directives.

Nous déclarons sous notre seule responsabilité que le produit remplit les Directives Européennes.

Richtlinie 1

Directive / Directive

Name

Name / Nom

EMC

Fundstelle

Reference / Référence

2014/30/EU

Bemerkung

Comment / Remarque

Datum der Erstanbringung des CE-Zeichens 2006

auf dem Produkt

Date of first application of the CE mark to the product / Date

de 1ère application du sigle sur le produit

Dokument-Nr.

CE 710

EU-Konformitätserklärung

Seite: 1 von 5

Document No. / Document n°.

7 Declaration of Conformity

JUMO GmbH & Co. KG

Moritz-Juchheim-Straße 1
36039 Fulda, Germany

Tel.: +49 661 6003-0
Fax: +49 661 6003-500

E-Mail: mail@jumo.net
Internet: www.jumo.net



More than sensors + automation

Angewendete Normen/Spezifikationen

Standards/Specifications applied / Normes/Spécifications appliquées

Fundstelle

Reference / Référence

EN 61326-1

Ausgabe

Edition / Édition

2013

Bemerkung

Comment / Remarque

Gültig für Typ

Valid for Type / Valable pour le type

706581/...

Richtlinie 2

Directive / Directive

Name

Name / Nom

LVD

Fundstelle

Reference / Référence

2014/35/EU

Bemerkung

Comment / Remarque

Datum der Erstanbringung des CE-Zeichens 2006

auf dem Produkt

Date of first application of the CE mark to the product / Date

de 1ère application du sigle sur le produit

Angewendete Normen/Spezifikationen

Standards/Specifications applied / Normes/Spécifications appliquées

Fundstelle

Reference / Référence

EN 61010-1

Ausgabe

Edition / Édition

2010

Bemerkung

Comment / Remarque

Gültig für Typ

Valid for Type / Valable pour le type

706581/*-**-**-33-**-**

706581/*-**-**-33-**-350-*

706581/*-**-**-33-**-444-*

Dokument-Nr.

Document No. / Document n°.

CE 710

EU-Konformitätserklärung

Seite: 2 von 5

7 Declaration of Conformity

JUMO GmbH & Co. KG

Moritz-Juchheim-Straße 1
36039 Fulda, Germany

Tel.: +49 661 6003-0
Fax: +49 661 6003-500

E-Mail: mail@jumo.net
Internet: www.jumo.net



More than sensors + automation

Richtlinie 3

Directive / Directive

Name

RoHS

Name / Nom

Fundstelle

2011/65/EU

Reference / Référence

Bemerkung

Comment / Remarque

Datum der Erstanbringung des CE-Zeichens auf dem Produkt 2017

Date of first application of the CE mark to the product / Date de 1ère application du sigle sur le produit

Angewendete Normen/Spezifikationen

Standards/Specifications applied / Normes/Spécifications appliquées

Fundstelle

Reference / Référence

Ausgabe

Edition / Édition

Bemerkung

Comment / Remarque

VDK Umweltrelevante Aspekte V1
bei der Produktentwicklung und
-gestaltung

Gültig für Typ

Valid for Type / Valable pour le type

706581/...

Richtlinie 4

Directive / Directive

Name

ATEX

Name / Nom

Fundstelle

2014/34/EU

Reference / Référence

Bemerkung

Mod. B+D

Comment / Remarque

Datum der Erstanbringung des CE-Zeichens auf dem Produkt 2008

Date of first application of the CE mark to the product / Date de 1ère application du sigle sur le produit

Dokument-Nr.
Document No. / Document n°.

CE 710

EU-Konformitätserklärung

Seite: 3 von 5

7 Declaration of Conformity

JUMO GmbH & Co. KG

Moritz-Juchheim-Straße 1
36039 Fulda, Germany

Tel.: +49 661 6003-0
Fax: +49 661 6003-500

E-Mail: mail@jumo.net
Internet: www.jumo.net



More than **sensors + automation**

Angewendete Normen/Spezifikationen

Standards/Specifications applied / Normes/Spécifications appliquées

Fundstelle

Reference / Référence

EN 60079-0

EN 60079-2

Ausgabe

Edition / Édition

2012+A11:2013

2014

Bemerkung

Comment / Remarque

Gültig für Typ

Valid for Type / Valable pour le type

706581/*-*-*-*-*-*443-*

706581/*-*-*-*-*-*444-*

EU-Baumusterprüfbescheinigung 4.1

EU type examination certificate / Certificat d'examen de type UE

Fundstelle

Reference / Référence

SEV 08 ATEX 0155 U

Benannte Stelle

Notified Body / Organisme notifié

Eurofins Electrosuisse Product Testing AG

Kennnummer

Identification no. / N° d'identification

1258

Anerkannte Qualitätssicherungssysteme der Produktion

Recognized quality assurance systems of production / Systèmes de qualité reconnus de production

Benannte Stelle

Notified Body / Organisme notifié

TÜV NORD CERT GmbH

Kennnummer

Identification no. / N° d'identification

0044

Allgemeine Bemerkungen

General remarks / Observations générales

For Directive 2014/34/EU, this document is an attestation of conformity because the product is classified as a component.

Dokument-Nr.
Document No. / Document n°.

CE 710

EU-Konformitätserklärung

Seite: 4 von 5

7 Declaration of Conformity

JUMO GmbH & Co. KG

Moritz-Juchheim-Straße 1
36039 Fulda, Germany

Tel.: +49 661 6003-0
Fax: +49 661 6003-500

E-Mail: mail@jumo.net
Internet: www.jumo.net



More than **sensors + automation**

Aussteller

Issued by / Etabli par

JUMO GmbH & Co. KG

Ort, Datum

Place, date / Lieu, date

Fulda, 2018-04-18

Rechtsverbindliche Unterschriften

Legally binding signatures /

Signatures juridiquement valable

Bereichsleiter Vertrieb Inland / Globales
Produkt- und Branchenmanagement
ppa. Dimitrios Charisiadis

Qualitätsbeauftragter und Leiter Qualitätswesen
i. V. Harald Gienger

7 Declaration of Conformity

8 Type Examination Certificate



Electrosuisse
Product Testing



EU-Type Examination Certificate

- (1)
- (2) Equipment or protective system intended for use in potentially explosive atmospheres - **Directive 2014/34/EU**
- (3) Certificate number: **SEV 08 ATEX 0155 U**
- (4) Product: Logoscreen nt resp. fd Type:
706581 / xx-xxx-xx / xxx, 443, 706581 / xx-xxx-xx / xxx, 444
706585 / xx-xxx-xx / xxx, 443, 706585 / xx-xxx-xx / xxx, 444
- (5) Manufacturer: **JUMO GmbH & Co. KG**
- (6) Address: **Moritz-Juchheim-Strasse 1, 36039 Fulda, GERMANY**
- (7) The equipment and any acceptable variation thereto is specified in the schedule to this certificate and the documents therein referred to.
- (8) Eurofins, notified body No. 1258, in accordance with article 17 of Directive 2014/34/EU of the European parliament and of the council, dated 26 February 2014, certifies that this product has been found to comply with the essential health and safety requirements relating to the design and construction of products intended for use in potentially explosive atmospheres given in Annex II to the Directive.
The examination and test results are recorded in confidential report no 08-IK-0140.01 incl. E1 - E3, 18-Ex-0103.01 E4
- (9) Compliance with the essential health and safety requirements has been assured by compliance with:
EN 60079-0:12 + A11:13 EN 60079-2:14
Except in respect of those requirements listed at item 18 of the schedule.
- (10) The sign "U" is placed after the certificate number. It indicates that this certificate must not be mistaken for a certificate intended for an equipment or protective system. This partial certification may be used as a basis for certification of an equipment or protective system.
- (11) This EU type examination certificate relates only to design and construction of the specified product. Further requirements of this directive apply to the manufacturing process and supply of this product. These are not covered by this certificate.
- (12) The marking of the product shall include the following:

 **II 2G Ex pxb IIC Gb**
II 2D Ex pxb IIC Db

Eurofins Electrosuisse Product Testing AG
Notified Body ATEX

Martin Plüss
Product Certification



8 Type Examination Certificate



Electrosuisse
Product Testing

(13)

Appendix

(14)

EU-Type Examination Certificate no. SEV 08 ATEX 0155 U

(15) **Description of product**

The Logoscreen type 706581/xx-xxx-xx/xxx, 443, 706585/xx-xxx-xx/xxx, 443, 706581/xx-xxx-xx/xxx, 444, 706585/xx-xxx-xx/xxx, 444 is intended for the registration and display of physical measured quantities in industrial environments, as specified in the technical data. The device is suitable for mounting in switchgear cabinets with pressurised enclosure. At the front, the device can be used in potentially explosive atmospheres (Zone 1 or 21) under these conditions.

Type designation

The x's in the type designation can be replaced by numbers or letters relating to specific variants which have no influence on explosion protection and general safety.

Ratings

Supply circuit	
Rated voltage	Un = 100 ... 240 V AC/+10/-15 %
or	
Rated voltage	Un = 20 ... 30 V AC/DC
Frequency	fn = 48 ... 63 Hz
Power	Pn = 40 VA

Classification of installation and use:	stationary
Ingress protection:	IP65; IP67 optional
Rated ambient temperature range:	0 °C to +50 °C

(16) **Report number**

08-IK-0140.01 incl. E1 - E3, 18-Ex-0103.01 E4



8 Type Examination Certificate



Electrosuisse
Product Testing

(17) Specific conditions of use

1. For mounting the Logoscreen type 706581/xx-xxx-xx/xxx, 443, 706585/xx-xxx-xx/xxx, 443, 706581/xx-xxx-xx/xxx, 444, 706585/xx-xxx-xx/xxx, 444 in switchgear cabinets with the type of protection "px" or "pz" or "py", it must be ensured that:
 - a) The defined maximum permissible temperatures are not exceeded.
 - b) The degree of protection IP65 according to the standard IEC/EN 60529 is achieved (mounting seal).
2. The Logoscreen type 706581/xx-xxx-xx/xxx, 443, 706585/xx-xxx-xx/xxx, 443, 706581/xx-xxx-xx/xxx, 444, 706585/xx-xxx-xx/xxx, 444 is a component (Ex component) of the equipment group II, Category 2G according to Directive 2014/34/EU additional I. The installation of these components is subject to a separate conformity assessment procedure.
The requirements of EN 60079-14 must be observed for use/installation.
3. The Logoscreen type 706581/xx-xxx-xx/xxx, 443, 706585/xx-xxx-xx/xxx, 443, 706581/xx-xxx-xx/xxx, 444, 706585/xx-xxx-xx/xxx, 444 is also a component (Ex component) of the equipment group II, Category 2D according to Directive 2014/34/EU additional I. The installation of these components is subject to a separate conformity assessment procedure.
The requirements of EN 60079-14 must be observed for use/installation.
4. The permissible ambient temperature range – internally and externally – is 0 °C to +50 °C.
5. The outside temperature on the front side of the Logoscreen type 706581/xx-xxx-xx/xxx, 443, 706585/xx-xxx-xx/xxx, 443, 706581/xx-xxx-xx/xxx, 444, 706585/xx-xxx-xx/xxx, 444 reaches maximum 69°C under fault conditions.
6. WARNING: Battery is located inside this enclosure. Do not open when an explosive atmosphere is present.
7. WARNING: This pressurized enclosure contains a battery which remains connected after the external power has been isolated. The removal of the battery should be considered if the housing will be unprotected by Ex "p" for a significant amount of time.

(18) Essential health and safety requirements

In addition to the essential health and safety requirements (EHSRs) covered by the standards listed at item 9, the following are considered relevant to this product, and conformity is demonstrated in the report:

Clause	Subject
None	

(19) Drawings and Documents

See test report "Manufacturer's Documents"



8 Type Examination Certificate

 产品组别 Product group: 706581		产品中有害物质的名称及含量 China EEP Hazardous Substances Information						
		Component Name						
部件名称 Component Name		铅 (Pb)	汞 (Hg)	镉 (Cd)	六价铬 (Cr(VI))	多溴联苯 (PBB)	多溴二苯醚 (PBDE)	
外壳 Housing (Gehäuse)		X	○	○	○	○	○	
过程连接 Process connection (Prozessanschluss)		○	○	○	○	○	○	
螺母 Nuts (Mutter)		○	○	○	○	○	○	
螺栓 Screw (Schraube)		○	○	○	○	○	○	

本表格依据SJ/T 11364的规定编制。
 This table is prepared in accordance with the provisions SJ/T 11364.
 ○：表示该有害物质在该部件所有均质材料中的含量均在GB/T 26572规定的限量要求以下。
 Indicate the hazardous substances in all homogeneous materials' for the part is below the limit of the GB/T 26572.
 x：表示该有害物质至少在该部件的某一均质材料中的含量超出GB/T 26572规定的限量要求。
 Indicate the hazardous substances in at least one homogeneous materials' of the part is exceeded the limit of the GB/T 26572.

9 China RoHS

A

Accessories *13*
ATEX *6, 12*

B

Back panel *26*

C

Climatic conditions *15*
Commissioning *5*
CompactFlash *8*
Connection diagram *26*

D

Device documentation available on the website *8*
Device documentation in printed form *7*
Device documentation in the form of PDF files *7*
Device version, identification of *11*
Dimensions *15*
Documentation, arrangement of *7*

E

Electrical connection *21*
Electrostatic discharge (ESD) *5*
Explosive atmosphere *6, 21*

F

Functional test *35*

I

Installation *15*
Installation notes *21*
Installation site *15*
Intended use *6*
Introduction *5*

M

Mounting *16, 18*

N

Nameplate 11
Note signs 9

O

Order details 12

P

Panel cut-out 15
Panel mounting 16, 18
Panel seal 6, 16, 18
PCA3000 8
PCC 8
Production date 11

R

Returning 5

S

Safe use 6
Seal 6, 16, 18
Standard accessories 13
Start-up screen 35

T

Technical data 37
Typographical conventions 9

U

Use 6

V

Views 15
Visualization 35

W

Warning signs 9
Warranty 5



JUMO GmbH & Co. KG

Street address:
Moritz-Juchheim-Straße 1
36039 Fulda, Germany
Delivery address:
Mackenrodtstraße 14
36039 Fulda, Germany
Postal address:
36035 Fulda, Germany
Phone: +49 661 6003-0
Fax: +49 661 6003-607
Email: mail@jumo.net
Internet: www.jumo.net

JUMO Instrument Co. Ltd.

JUMO House
Temple Bank, Riverway
Harlow, Essex, CM20 2DY, UK
Phone: +44 1279 63 55 33
Fax: +44 1279 62 50 29
Email: sales@jumo.co.uk
Internet: www.jumo.co.uk

JUMO Process Control, Inc.

6733 Myers Road
East Syracuse, NY 13057, USA
Phone: +1 315 437 5866
Fax: +1 315 437 5860
Email: info.us@jumo.net
Internet: www.jumousa.com

