

LOGOSCREEN *cf*
Paperless Recorder
with CompactFlash card
as storage medium

B 70.6570.4
Installation Instructions

12.06/00434186

Menu structure of the paperless recorder

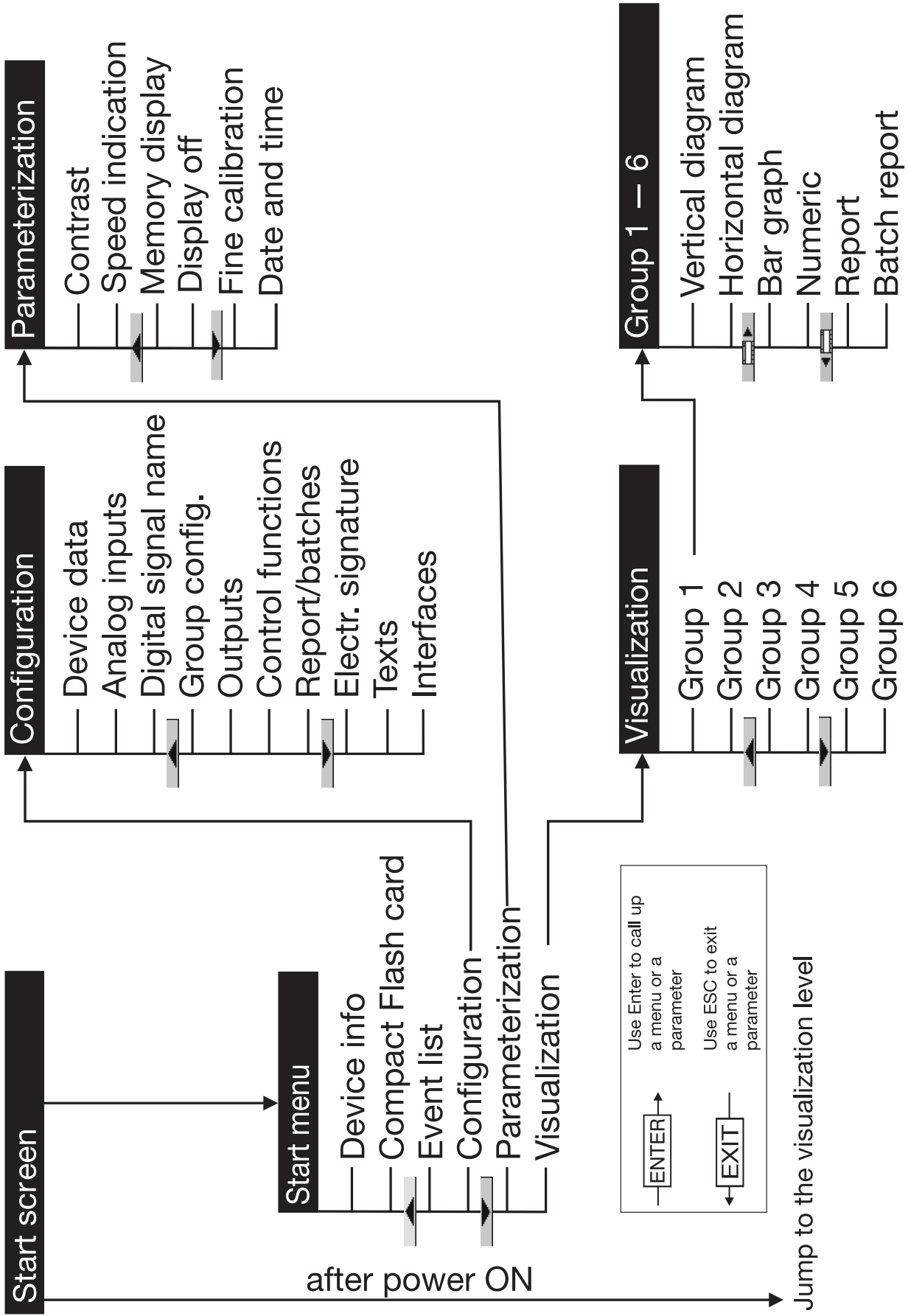

Contents

1	Introduction	5
1.1	Preface	5
1.2	Arrangement of the documentation	6
1.3	Typographical conventions	8
2	Identifying the instrument version	9
2.1	Nameplate	9
2.2	Type designation	10
2.3	Standard accessories	11
2.4	Accessories	11
3	Installation	13
3.1	Location and climatic conditions	13
3.2	Mounting in position	13
4	Electrical connection	15
4.1	Installation notes	15
4.2	Procedure	16
4.3	Connection diagram	17
5	Function check	21
6	Device replacement / software update	23
7	Technical data	25
8	Index	29

Contents

1.1 Preface



Please read these Installation Instructions before commissioning the instrument. Keep the instructions in a place that is accessible to all users at all times.

Please assist us to improve these installation instructions, where necessary.

Your suggestions will be appreciated.

Phone +49 661 6003-0
Fax +49 661 6003-607
E-mail mail@jumo.net



If any problems should occur during commissioning, please do not carry out any manipulations on the unit, as this could endanger your rights under the instrument warranty!

Please contact the nearest subsidiary or the head office in such a case.



When returning modules, assemblies and components, the regulations of EN 61340-5-1 and EN 61340-5-2 “Protection of electronic devices from electrostatic phenomena” must be observed. Use only the appropriate **ESD** packaging for transport.

Please note that we cannot accept any liability for damage caused by ESD (electrostatic discharge).

1 Introduction

1.2 Arrangement of the documentation

The documentation for this instrument is addressed to the equipment manufacturer (OEM) and users with appropriate technical expertise. It consists of the following parts:

Instrument documentation in printed form

B 70.6570.1 Operating Instructions

The operating instructions are an extract from the operating manual. They cover the basic operation of the paperless recorder.

B 70.6570.4 Installation Instructions

The installation instructions describe the installation of the paperless recorder and the connection of the supply and signal cables. The instructions also contain a list of the technical data.

Instrument documentation in PDF file format

The “Instrument documentation in PDF file format” is on the CD that is included in the delivery.

B 70.6570.0 Operating Manual

It contains information about commissioning, operation and parameter setting on the instrument as well as through the PC setup program (option).

B 70.6570.1 Operating Instructions

The operating instructions are an extract from the operating manual. They cover the basic operation of the paperless recorder.

B 70.6570.2.0 Interface description (serial interfaces)

This provides information on the communication (RS232; RS422/RS485) with supervisory systems.

Interface description (Ethernet interface)

This provides information on the connection of a paperless recorder to a company-internal network. The description is incorporated in the B 70.6570.2.0

B 70.6570.2.1 Interface description (LON interface)

This provides information on the connection and use of modules of the “JUMO mTRON automation system”.

B 70.6570.2.3 Interface description (PROFIBUS-DP interface)

This provides information on the connection of a paperless recorder to a PROFIBUS-DP system.

B 70.6570.4 **Installation instructions**

The installation instructions describe the installation of the paperless recorder and the connection of the supply and signal cables. They also contain a list of the technical data.

T 70.6570 **Data sheet**

The data sheet contains general information, the order details and the technical data.



All documents are available on the Internet for downloading at www.jumo.net

1 Introduction

1.3 Typographical conventions

Warning signs

The signs for **Danger** and **Caution** are used in this manual under the following conditions:



Danger

This symbol is used where there may be **danger to personnel** if the instructions are disregarded or not followed accurately!



Caution

This symbol is used where there may be **damage to equipment or data** if the instructions are disregarded or not followed accurately!



Caution

This symbol is used where special precautions must be taken when handling **electrostatically sensitive components**.

Note signs



Note

This symbol is used to draw your **special attention** to a remark.



Reference

This sign refers to **further information** in other manuals, chapters or sections.

abc¹

Footnote

Footnotes are comments that **refer to specific parts** of the text. Footnotes consist of two parts: a marking in the text and the footnote text.

The marking in the text is arranged as continuous superscript numbers.

*

Action

This sign marks the description of a **required action**.

The individual steps are indicated by this asterisk, e. g.

* Press the  key

* Confirm with 

2 Identifying the instrument version

2.1 Nameplate

Identification

Position The nameplate is affixed to the paperless recorder.

Contents It contains important information such as:

Description	Designation on nameplate	Example
Instrument type	Typ	706570/10-888,000-51-0032-0032-23,020
Sales number	VARTN	70/00342163
Production number	F-Nr	0022969000004180006
Supply voltage		AC 110 ... 240V +10/-15%, 48...63Hz

Typ Please compare the type that was supplied with your order details. You can identify the type by referring to Chapter 2.2 “Type designation”.

VARTN The sales number unambiguously designates the article in the catalog. It is used for communication between the customer and the sales department.

F-Nr The production number indicates the production date (year/week). The figures concerned are in position 12, 13, 14, 15.

Example:

F-Nr 002296900000**4180006**

This shows that the paperless recorder was manufactured in 2004, week 18.

2 Identifying the instrument version

2.3 Standard accessories

- 1 Installation Instructions B 70.6570.4
- 1 Operating Instructions B 70.6570.1
- 2 mounting brackets
- 1 cable-tie with foot (can be released)
for strain relief of the sensor connection cables
- 1 CD with additional documentation
(see Chapter 1.2 “Arrangement of the documentation”)

2.4 Accessories

- Setup program
- PC Evaluation software (PCA3000)
- PCA Communications software (PCC)
- PC interface cable with TTL/RS232 converter and adapter,
for setup program, Sales No. 70/00350260

2 Identifying the instrument version

3.1 Location and climatic conditions

The location should be as free as possible from shock and vibration. Stray electromagnetic fields from motors, transformers etc. should be avoided.

The ambient temperature at the location can be 0 to +45°C, at a relative humidity of $\leq 75\%$, no condensation.

⇒ Chapter 4.1 “Installation notes”

3.2 Mounting in position

Outline drawings

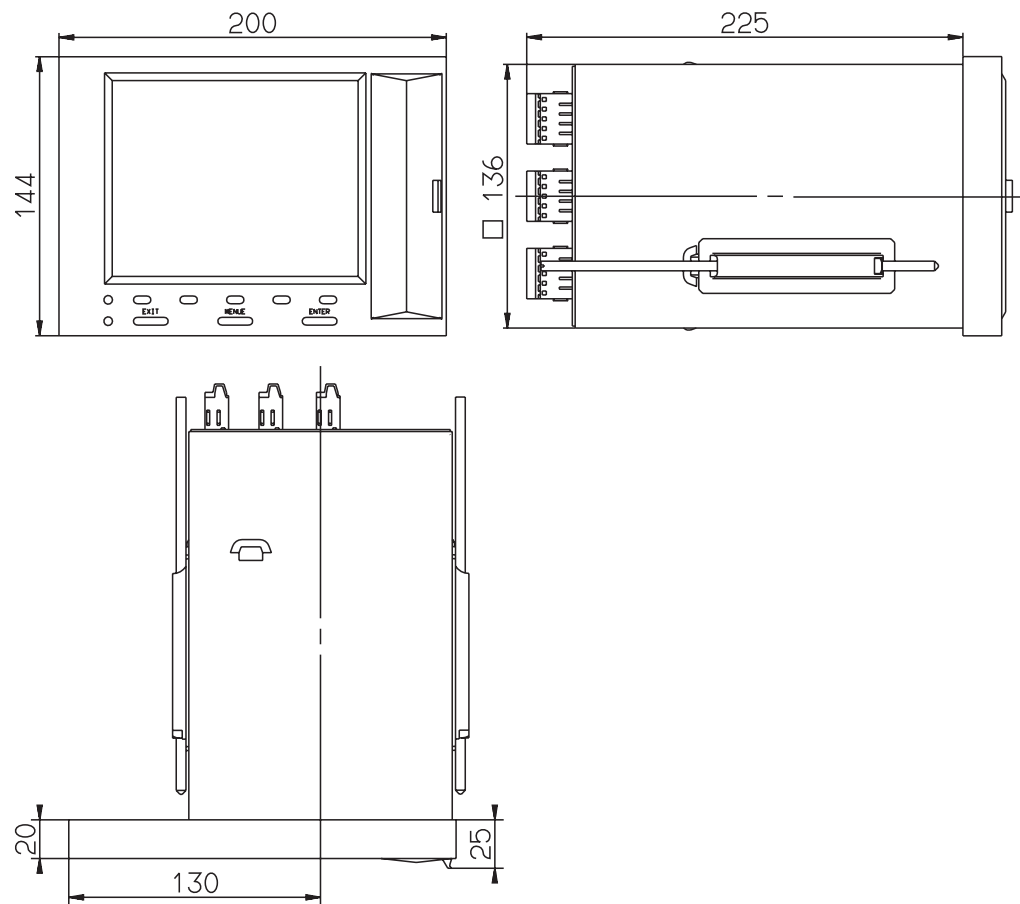

Stainless steel front

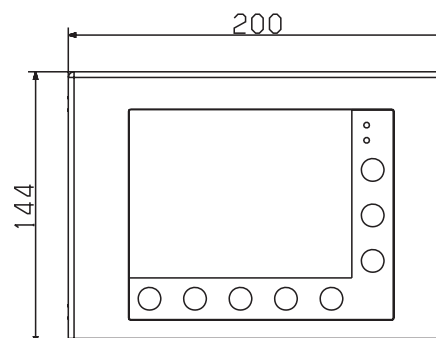

3 Installation

Fitting into the panel

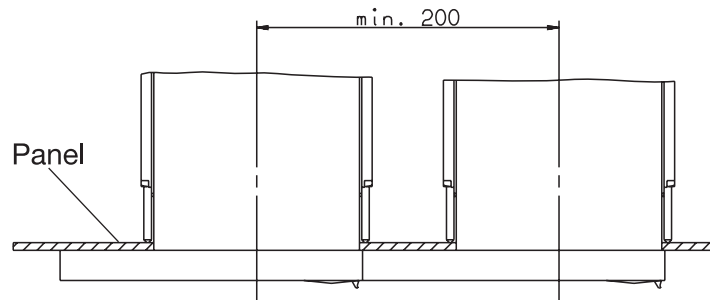

Fitting in position

- * Insert the paperless recorder from the front into the panel cut-out.
- * From the back of the panel, hook the two mounting brackets into the recesses on the sides of the housing. The flat sides of the brackets must be against the housing.
- * Place the mounting brackets against the rear of the panel and tighten them evenly.

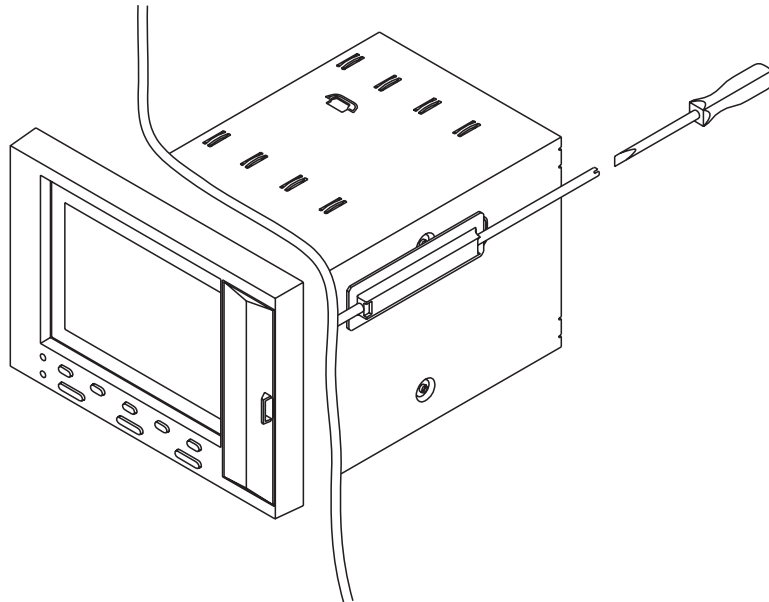

4.1 Installation notes

- The choice of the cable, the installation and the electrical connection must conform to the requirements of VDE 0100 “Regulations on the Installation of Power Circuits with nominal voltages below 1000V”, or the appropriate local regulations.
- Work inside the instrument must only be carried out to the extent described and, like the electrical connection, only by qualified personnel.
- If contact with live parts is possible while working on the instrument, it must be isolated from the supply on both poles.
- The electromagnetic compatibility (EMC) conforms to the standards and regulations listed under Technical Data.
⇒ Chapter 7 “Technical data”
- Run the input, output and supply cables separately, and not parallel to one another.
- All input and output cables without connection to the supply network must be arranged as twisted and screened cables. Earth the screen on the instrument side to the earth potential.
- Earth the instrument at the PE terminal to the protective conductor. This cable should have the same cross-section as the supply cable. Earthing cables should be run in a star layout to a common earthing point which is connected to the protective conductor of the supply. Do not loop the earthing cable, i.e. do not run it from one instrument to another.
- Do not connect any additional loads to the supply terminals of the instrument.
- The instrument is not suitable for use in hazardous areas.
- Inductive loads close to the instrument, such as contactors or solenoid valves, should have RC modules fitted for interference suppression.
- The supply to the instrument must be provided with additional fusing. Depending on the supply voltage, the following fuse values apply:

20 – 30V AC/DC, 48 – 63Hz : fuse 2A slow

110 – 240V AC +10/-15%, 48 – 63Hz : fuse 1A slow

A type-G miniature cartridge fuse marked F1 is built into the instrument itself:

20 – 30V AC/DC, 48 – 63Hz : fuse 1.6A slow

110 – 240V AC +10/-15%, 48 – 63Hz : fuse 0.63A slow

4 Electrical connection

4.2 Procedure

- * Carry out electrical connection as per Chapter 4.3 “Connection diagram”.
- * If necessary, use cable-ties for strain relief of connecting cables.

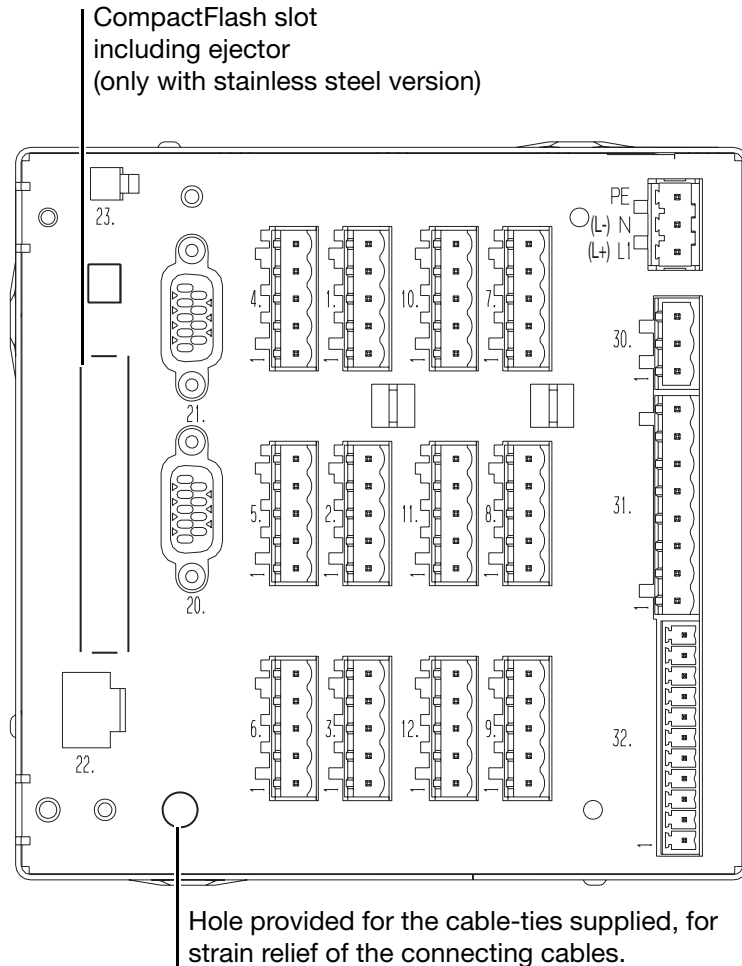

Connector	Function
1 – 12	Analog inputs
20	RS232C or RS422 or RS485
21	LON or PROFIBUS-DP
22	Ethernet
23	Setup
30	Relay output
31	Relay outputs
32	Digital I/O (logic inputs)

4 Electrical connection

4.3 Connection diagram



The electrical connection must only be carried out by qualified personnel.

Back panel

Rear view with pluggable screw terminals

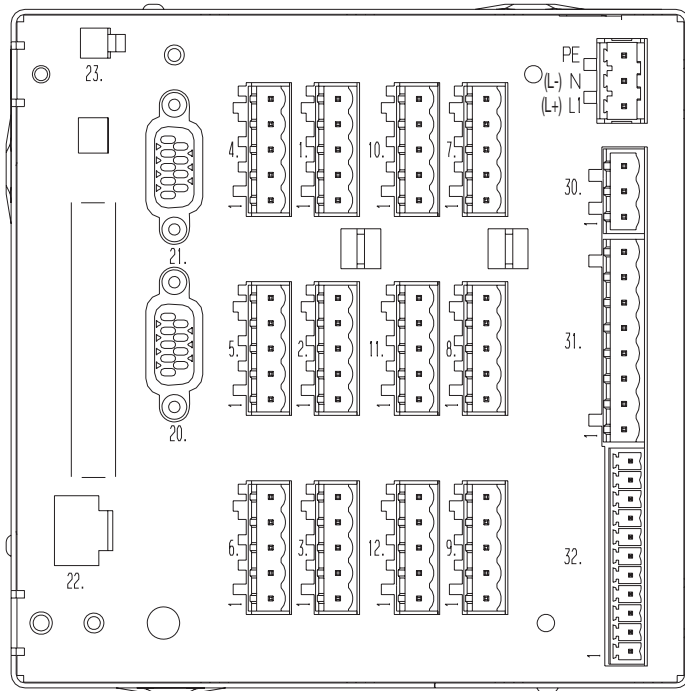





	Terminal assignment	Connector	Connection diagram
Supply	Supply voltage as per data sheet	L1(L+) N (L-) PE	
	Thermocouple	1 to 12	
Analog inputs	Resistance thermometer in 2-wire circuit	1 to 12	
	Resistance thermometer in 3-wire circuit	1 to 12	
	Resistance thermometer in 4-wire circuit	1 to 12	

4 Electrical connection

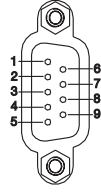
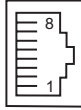
Terminal assignment	Connector	Connection diagram	
Resistance transmitter	1 to 12		
Potentiometer in 2-wire circuit	1 to 12		
Potentiometer in 3-wire circuit	1 to 12		
Potentiometer in 4-wire circuit	1 to 12		
Voltage input $\leq 200\text{mV}$	1 to 12		
Voltage input $> 200\text{mV}$	1 to 12		
Current input	1 to 12		
Interfaces	RS232C 9-pole SUB-D socket 2 RxD receive data 3 TxD transmit data 5 GND ground	20	
	RS422 9-pole SUB-D socket (extra code) 3 TxD+ transmit data + 4 RxD+ receive data + 5 GND ground 8 TxD- transmit data - 9 RxD- receive data -	20	
	RS485 9-pole SUB-D socket (extra code) 3 TxD+/RxD+ transmit/receive data + 5 GND ground 8 TxD-/RxD- transmit/receive data -	20	
	LON 9-pole SUB-D socket (extra code) 3 Net_A 9 Net_B	21	

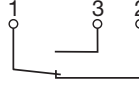
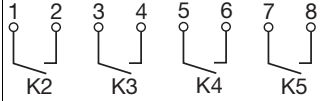
4 Electrical connection

	Terminal assignment	Connector	Connection diagram
Interfaces	PROFIBUS-DP 9-pole SUB-D socket (extra code) 3 RxD/TxD-P B-cable receive/transmit data-Plus 5 DGND data transmission potential 6 VP supply voltage-Plus 8 RxD/TxD-N A-cable receive/transmit data-N	21	
	Ethernet RJ45 socket (extra code) 1 TX+ transmit data + 2 TX- transmit data - 3 RX+ receive data + 6 RX- receive data -	22	
	Setup interface The recorder also has a setup interface on the front panel (wired in parallel). Do not use both at the same time.	23	
Relay outputs	Relay K1 (changeover, 3A, 230V AC) ¹	30	
	Relay K2 to K5 (make/break contact, 3A, 230V AC) ¹ (extra code)	31	
Digital I/O	1. with resistive load. SELV circuits and supply circuits must not be combined.		
	Open-collector output (25V max., 100mA max.) (extra code) 3 ground 4 collector	32	

4 Electrical connection

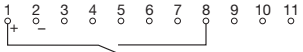
	Terminal assignment	Connector	Connection diagram																
Digital I/O	Logic inputs, voltage-operated (extra code) LOW = -3 to +5V DC HIGH = 12 to 30V DC 1 +24V/50mA auxiliary supply not stabilized 2 GND 5 Logic input 7 6 Logic input 6 7 Logic input 5 8 Logic input 4 9 Logic input 3 10 Logic input 2 11 Logic input 1	32	 <p>Example: input 4 (terminal 8) contact-operated</p> <table border="1"> <thead> <tr> <th>Input</th> <th>Terminal</th> </tr> </thead> <tbody> <tr> <td>1</td> <td>11</td> </tr> <tr> <td>2</td> <td>10</td> </tr> <tr> <td>3</td> <td>9</td> </tr> <tr> <td>4</td> <td>8</td> </tr> <tr> <td>5</td> <td>7</td> </tr> <tr> <td>6</td> <td>6</td> </tr> <tr> <td>7</td> <td>5</td> </tr> </tbody> </table>	Input	Terminal	1	11	2	10	3	9	4	8	5	7	6	6	7	5
Input	Terminal																		
1	11																		
2	10																		
3	9																		
4	8																		
5	7																		
6	6																		
7	5																		

5 Function check

When the paperless recorder is installed and connected, it can be started up. After the supply voltage has been connected or switched on, the start screen will appear briefly.

Start screen

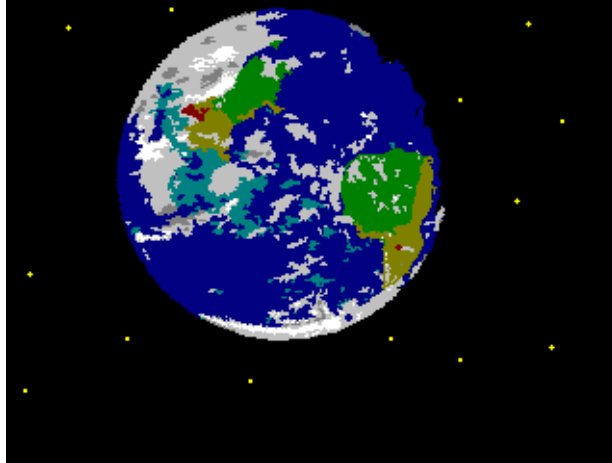

After the end of the initialization phase, the visualization level is automatically started.

Visualization level

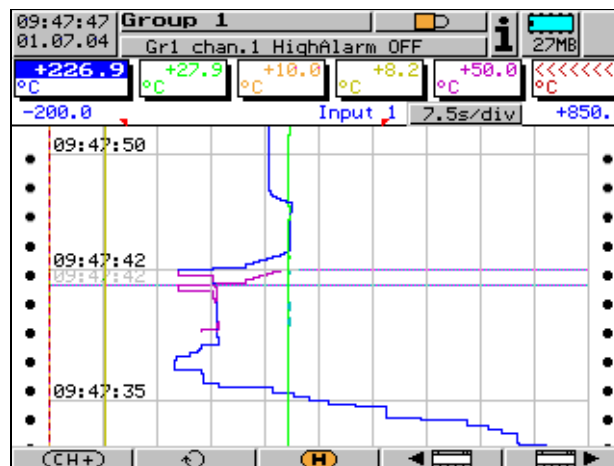

The recorder is now in recording mode.

Further steps



The instrument can be configured by an authorized person, either from the instrument keys or by using the setup program. Additional information about the configuration can be found in the Operating Manual B 70.6570.0.

Afterwards, please check again that connection, configuration and operational mode are correct.

5 Function check

6 Device replacement / software update

If you need to replace the device or update the software, this chapter will help you back up and restore all necessary settings and parameters.

* Fill in this page before replacing the device.

Proof of service

Order number : _____
 Date : _____
 Device designation : _____
 Production number : _____

Activity

		done	
		yes	no
1.	Save measurement data to CF card or through the PCC software.		
2.	Save configuration data (setup) to CF card or through the setup software.		
3.	If used, save reports to CF card. Please note: reports cannot be terminated through the PC software.		
4.	If used, read out counter values with the setup software and write them down. Counter 1 : _____ Counter 2 : _____ Ext. counter 1 : _____ Ext. counter 2 : _____		
5.	Read off IP address, Subnet-Mask and Gateway on the device or through the setup software and write them down. IP address : _____ . _____ . _____ . _____ Subnet-Mask : _____ . _____ . _____ . _____ Gateway : _____ . _____ . _____ . _____		
6.	Read off values for fine calibration for all analog inputs on the device and write them down. Start act. / Start targ./ End act. / End targ. Analog input 1 : _____ / _____ / _____ / _____ Analog input 2 : _____ / _____ / _____ / _____ Analog input 3 : _____ / _____ / _____ / _____ Analog input 4 : _____ / _____ / _____ / _____ Analog input 5 : _____ / _____ / _____ / _____ Analog input 6 : _____ / _____ / _____ / _____ Analog input 7 : _____ / _____ / _____ / _____ Analog input 8 : _____ / _____ / _____ / _____ Analog input 9 : _____ / _____ / _____ / _____ Analog input 10 : _____ / _____ / _____ / _____ Analog input 11 : _____ / _____ / _____ / _____ Analog input 12 : _____ / _____ / _____ / _____		

6 Device replacement / software update

Analog inputs (channels 1 – 12)

Thermocouple

Designation	Type	Standard	Range	Linearization accuracy ¹
Fe-Con	L	DIN 43710	-200 to +900°C	±0.1%
Fe-Con	J	EN 60584	-210 to +1200°C	±0.1% above -100°C
Cu-Con	U	DIN 43710	-200 to +600°C	±0.1% above -150°C
Cu-Con	T	EN 60584	-270 to +400°C	±0.15% above -150°C
NiCr-Ni	K	EN 60584	-270 to +1372°C	±0.1% above -80°C
NiCr-Con	E	EN 60584	-270 to +1000°C	±0.1% above -80°C
NiCrSi-NiSi	N	EN 60584	-270 to +1300°C	±0.1% above -80°C
Pt10Rh-Pt	S	EN 60584	-50 to +1768°C	±0.15% above 0°C
Pt13Rh-Pt	R	EN 60584	-50 to +1768°C	±0.15% above 0°C
Pt30Rh-Pt6Rh	B	EN 60584	0 to 1820°C	±0.15% above 400°C
Chromel-Copel			-200 to +800°C	±0.15%
Shortest span	L, J, U, T, K, E, N, Chromel-Copel: S, R, B:			100°C 500°C
Range start/end	freely programmable within the limits in 0.1°C steps			
Cold junction	Pt100 internal or thermostat external constant			
Cold junction accuracy (internal)	± 1°C			
Cold junction temperature (external)	-50 to +100°C adjustable through setup software			
Sampling cycle	6 or 12 channels 125msec			
Input filter	2nd order digital filter; filter constant adjustable from 0 to 10.0sec			
Test voltage	500V (across optocoupler)			
Resolution	> 14 bit			
Features	also programmable in °F			

1. The linearization accuracy refers to the maximum span.
The linearization accuracy is reduced for shorter spans.

Resistance thermometer

Designation	Standard	Connection	Range	Linearization accuracy	Measuring current
Pt 100	EN 60751	2/3-wire	-200 to +500°C	±0.4°C	500µA
		2/3-wire	-200 to +850°C	±0.8°C	250µA
		4-wire	-200 to +500°C	±0.4°C	500µA
		4-wire	-200 to +850°C	±0.5°C	250µA
Pt 100	JIS	2/3-wire	-200 to +500°C	±0.4°C	500µA
		2/3-wire	-200 to +650°C	±0.8°C	250µA
		4-wire	-200 to +500°C	±0.4°C	500µA
		4-wire	-200 to +650°C	±0.5°C	250µA
Pt 500	EN 60751	2/3-wire	-200 to +500°C	±0.4°C	250µA
		2/3-wire	-200 to +850°C	±0.8°C	250µA
		4-wire	-200 to +500°C	±0.4°C	250µA
		4-wire	-200 to +850°C	±0.5°C	250µA
Pt 1000	EN 60751	2/3-wire	-200 to +500°C	±0.4°C	500µA
		2/3-wire	-200 to +850°C	±0.8°C	250µA
		4-wire	-200 to +500°C	±0.4°C	500µA
		4-wire	-200 to +850°C	±0.5°C	250µA
Ni 100	EN 60751	2/3-wire	-60 to +180°C	±0.4°C	500µA
		4-wire	-60 to +180°C	±0.4°C	500µA

7 Technical data

Designation	Standard	Connection	Range	Linearization accuracy	Measuring current
Cu 50		2/3-wire	-50 to +100°C	±0.5°C	500µA
		2/3-wire	-50 to +200°C	±0.9°C	250µA
		4-wire	-50 to +100°C	±0.5°C	500µA
		4-wire	-50 to +200°C	±0.6°C	250µA
Connection type		2-, 3- or 4-wire circuit			
Shortest span		15°C			
Sensor lead resistance		max. 30 Ω per core for 3-/4-wire circuit max. 10Ω per core for 2-wire circuit			
Range start/end		freely programmable within the limits in 0.1°C steps			
Sampling cycle		6 or 12 channels 125msec			
Input filter		2nd order digital filter; filter constant adjustable from 0 to 10sec			
Test voltage		500V (across optocoupler)			
Resolution		> 14bit			
Features		also programmable in °F			

Resistance transmitter and potentiometer

Range	Accuracy	Measuring current
up to 180Ω	±150mΩ	500µA
up to 390Ω	±300mΩ	250µA
up to 2000Ω	±2Ω	500µA
up to 4000Ω	±4Ω	250µA
Connection type		resistance transmitter: 3-wire circuit potentiometer: 2-/3-wire circuit
Shortest span		6Ω
Sensor lead resistance		max. 30Ω per core for 4-wire circuit max. 20Ω per core for 2- and 3-wire circuit up to 200 Ω range: max. 10 Ω per core for 2- and 3-wire circuit
Resistance values		freely programmable within the limits in 0.1 Ω steps
Sampling cycle		6 or 12 channels 125msec
Input filter		2nd order digital filter; filter constant adjustable from 0 to 10.0sec

Input for DC voltage, DC current

Basic range	Accuracy	Input resistance
-20 to +70mV	±80µV	$R_{IN} \geq 1 \text{ M}\Omega$
-5 to +105mV	±100µV	$R_{IN} \geq 1 \text{ M}\Omega$
-10 to +210mV	±240µV	$R_{IN} \geq 1 \text{ M}\Omega$
-0.5 to +12V	±6mV	$R_{IN} \geq 470 \text{ k}\Omega$
-0.05 to +1.2V	±1mV	$R_{IN} \geq 470 \text{ k}\Omega$
-1.2 to +1.2V	±2mV	$R_{IN} \geq 470 \text{ k}\Omega$
-12 to +12V	±12mV	$R_{IN} \geq 470 \text{ k}\Omega$
Shortest span		5mV
Range start/end		freely programmable within the limits (up to 999mV in 0.01 mV steps, above 1V in 1 mV steps)
-2 to +22mA	±20µA	burden voltage ≤ 1V
-22 to +22mA	±44µA	burden voltage ≤ 1V
Shortest span		0.5mA

7 Technical data

Range start/end	freely programmable within the limits in 0.1 mA steps
Sampling cycle	6 or 12 channels 125msec
Input filter	2nd order digital filter; filter constant adjustable from 0 to 10.0sec
Feature	adjustable linearizations for thermocouples and resistance thermometers (for connection of transmitters without linearization)

Transducer short-circuit/break

	Short-circuit ¹	Break ¹
Thermocouple	not detected	detected
Resistance thermometer	detected	detected
Resistance transmitter	detected	detected
Potentiometer	not detected	detected
Voltage up to $\pm 1V$	not detected	detected
Voltage $> \pm 1V$	not detected	not detected
Current	not detected	not detected

1. programmable reaction of instrument, e.g. triggering alarm

Logic inputs (extra code)

Number	7 to DIN VDE 0411, Part 500; max. 25Hz, max. 32V
Level	logic "0": -3 to +5V, logic "1": 12 to 30V
Sampling cycle	minimum 1 sec

Outputs

1 relay (ex-factory)	changeover, 3A, 230V AC ¹
4 relays (extra code)	make/break, 3A, 230V AC ¹
1 open-collector output (extra code)	max. 25V, max. 100mA
1 voltage output (extra code)	24V DC, 50mA

1. with resistive load. SELV circuits and supply circuits must not be combined.

External analog inputs / logic inputs / logic outputs

Type	JUMO mTRON automation system
Sampling cycle	1 sec
Technical data	see Data Sheet: 70.4015 Relay module 70.4020 Analog input module 70.4030 Logic module
Configuration	Project design software iTOOL (70.4090)

7 Technical data

Screen

Resolution	320 x 240 pixels
Size	5.7"
Number of colors	27 colors

Electrical data

Supply (switch-mode power supply)	110 – 240V AC +10/-15%, 48 – 63Hz or 20 – 30V AC/DC, 48 – 63Hz
Electrical safety	to EN 61 010, Part 1 of August 2002 overvoltage category II, pollution degree 2
Test voltages (type test) - mains supply circuit to measuring circuit - mains supply circuit to housing (protective conductor) - measuring circuits to measuring circuit and housing - electrical isolation between the analog inputs	with AC supply: 3.7kV/50Hz, 1 min, with AC/DC supply: 510V/50Hz, 1 min with AC supply: 2.3kV/50Hz, 1 min, with AC/DC supply: 510V/50Hz, 1 min 510V/50Hz, 1 min up to 30V AC and 50V DC
Supply voltage error	< 0.1 % of range span
Power consumption	approx. 25VA
Electrical connection	at rear by plug-in screw terminals, max. conductor cross-section 2.5mm ² or 2x 1.5mm ² with ferrules

Environmental influences

Ambient temperature range	0 to +45°C
Ambient temperature error	0.03 % per °C
Storage temperature range	-20 to +60°C
Climatic conditions	≤ 75% rel. humidity, no condensation
EMC - interference emission - immunity to interference	EN 61 326 Class A to industrial requirements

Housing

Housing front	zinc die-casting or stainless steel
Housing type	panel-mounting housing to DIN 43 700, galvanized steel sheet
Bezel size	200mm x 144mm
Depth behind panel	225mm
Panel cut-out	138 ^{+1.0} mm x 138 ^{+1.0} mm
Housing fixing	in panel to DIN 43 834
Operating position	unrestricted, taking into account the viewing angle of the screen, horizontal ±50°, vertical ±30°
Protection	to EN 60 529 Category 2, front IP54 (IP65 with extra code stainless steel front), rear IP20
Weight	approx. 3.5kg

A

Accessories *11*
Analog inputs *17*

B

Back panel *17*

C

Climatic conditions *13*
Commissioning *5*
CompactFlash *16*
Connection diagram *17*
Cover for back panel *17*

D

Digital I/O *19–20*
Documentation, arrangement of *6*

E

Electrical connection *15*
Electrostatic discharge (ESD) *5*

F

Fitting into the panel *14*
Function check *21*

I

Identification of namplate *9*
Installation *13*
Installation notes *15*
Instrument documentation in PDF file format *6*
Instrument documentation in printed form *6*
Instrument version, identification of *9*
Interfaces *18–19*
Introduction *5*

L

Location *13*

M

Mounting in position *13*

N

Nameplate *9*

Note signs *8*

O

Outline drawings *13*

P

PROFIBUS-DP *10, 19*

R

Rear view *17*

Relay outputs *19*

Returning *5*

S

Sales documentation in printed form *6*

Stainless steel *16, 28*

Standard accessories *11*

Start screen *21*

Supply *17*

T

Technical data *25*

Type designation *10*

Typographical conventions *8*

V

Visualization level *21*

W

Warning signs *8*

Warranty *5*



JUMO GmbH & Co. KG

Street address:
Moltkestraße 13 - 31
36039 Fulda, Germany
Delivery address:
Mackenrodtstraße 14
36039 Fulda, Germany
Postal address:
36035 Fulda, Germany
Phone: +49 661 6003-0
Fax: +49 661 6003-607
e-mail: mail@jumo.net
Internet: www.jumo.net

JUMO Instrument Co. Ltd.

JUMO House
Temple Bank, Riverway
Harlow, Essex CM20 2TT, UK
Phone: +44 1279 635533
Fax: +44 1279 635262
e-mail: sales@jumo.co.uk
Internet: www.jumo.co.uk

JUMO Process Control, Inc.

8 Technology Boulevard
Canastota, NY 13032, USA
Phone: 315-697-JUMO
1-800-554-JUMO
Fax: 315-697-5867
e-mail: info@jumo.us
Internet: www.jumo.us