

JUMO

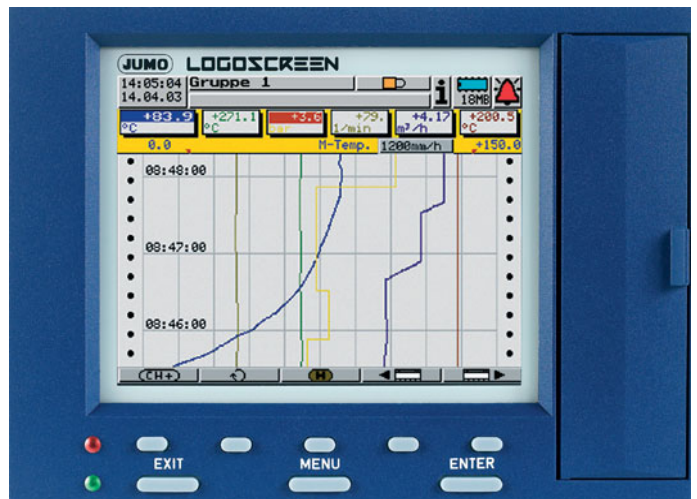

LOGOSCREEN es
Screen recorder
for safe acquisition of FDA-
compliant measurement
data

B 70.6560.2.1
Interface description LON

1	Introduction	5
1.1	Preface	5
1.2	Typographical conventions	6
1.2.1	Warning signs	6
1.2.2	Note signs	6
1.2.3	Presentation	6
2	General	7
2.1	Applications	7
2.2	System requirements	7
2.2.1	Configuring the mTRON modules	7
2.3	Identifying the interface	8
3	Connecting the interface	9
3.1	Connection diagram	9
3.2	Connecting configured mTRON modules	10
4	Operation and visualisation	11
4.1	Instrument info	11
4.2	External analogue inputs	12
4.3	External logic inputs	13
4.4	External counters	13
4.5	Group configuration	14

Contents

5	JUMO mTRON-iTOOL project design software	15
5.1	Establishing a network connection	15
5.2	Input network-variables	15
5.3	Output network-variables	16
5.4	Parameter setting	17
5.4.1	Module settings	18
5.5	mTRON modules	18
5.5.1	mTRON operating unit	18
5.5.2	Communication module	18
5.6	Project design example	19
6	Error handling	23
6.1	Response after a power failure	23
6.2	Response on failure of mTRON module	23

1.1 Preface

Please read this manual before starting up the interface. Keep this manual in a place which is at all times accessible to all users.

Please assist us to improve this manual.

Your suggestions will be most welcome.

Phone	within Germany	(0661) 6003-725
	from abroad	(++49) 661 6003-0
Fax	within Germany	(0661) 6003-681
	from abroad	(++49) 661 6003-607



All the necessary information for operating the interface is contained in these operating instructions. However, if any problems should still arise during start-up, you are asked not to carry out any prohibited manipulations. You could endanger your rights under the warranty!

Please contact the nearest subsidiary or the main factory.



When returning chassis, modules or components, the rules of EN 100 015 "Protection of electrostatically sensitive devices" have to be observed. Use only the appropriate **ESD** packaging material for transport.

Please note that we cannot be held liable for any damage caused by **ESD** (electrostatic discharges).

1 Introduction

1.2 Typographical conventions

1.2.1 Warning signs

The signs for **Danger** and **Warning** are used in this manual under the following conditions:



Danger

This symbol is used when there may be **danger to personnel** if the instructions are disregarded or not followed accurately!



Warning

This symbol is used when there may be **danger to equipment or data** if the instructions are disregarded or not followed accurately!



Warning

This symbol is used where special care is required when handling components liable to damage through electrostatic discharges.

1.2.2 Note signs



Note

This symbol is used when your attention is drawn to a **special remark**.



Reference

This sign refers to further information in other handbooks, chapters or sections.

abc¹

Footnote

Footnotes are notes which refer to certain points in the text. Footnotes consist of two parts:

Marking in the text and the footnote text.

The markings in the text are arranged as continuous raised numbers.

The footnote text (in smaller typeface) is placed at the bottom of the text and starts with a number and a full stop.

1.2.3 Presentation

0x0010

Hexadecimal number

A hexadecimal number is identified by being preceded by a "0x" (here: 16 decimal).

2.1 Applications

The LON interface is available for the connection of external modules of the JUMO mTRON automation system, in order to expand the screen recorder functionality.

All mTRON modules can be connected.

2.2 System requirements

The following requirements have to be met for the connection of external modules to the screen recorder :

- Screen recorder with LON interface (program version¹ from 100.02.01)
- Configured modules of the JUMO mTRON automation system

2.2.1 Configuring the mTRON modules

The mTRON modules are configured using the JUMO mTRON-iTOOL project design software. An interface cable is required for connecting mTRON modules to a PC.



The JUMO mTRON-iTOOL project design software can only be dispensed with if the mTRON modules have been configured by JUMO GmbH & Co. KG prior to delivery. In order for this to happen, the customer must have specified the required configuration in detail when ordering his measuring system.



The screen recorder can also operate without internal analogue channels. In this case, the measurements are obtained exclusively from the mTRON modules.

1. The program version can be requested in the menus of the screen recorder via *Instrument info* → *Version number*.

2 General

2.3 Identifying the interface

The LON interface is available as extra Code. The contents of the menu *Instrument info* → *Interface* show whether it is implemented in the system.

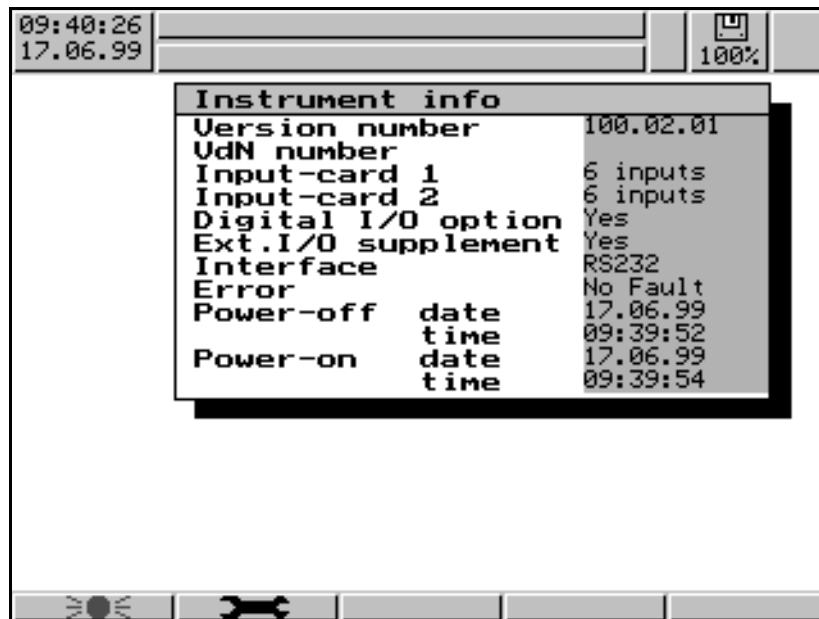

If the entry *Instrument info* → *Ext. I/O supplement* is set to *Yes*, the LON interface is available.

3 Connecting the interface

3.1 Connection diagram

Rear view of the screen recorder

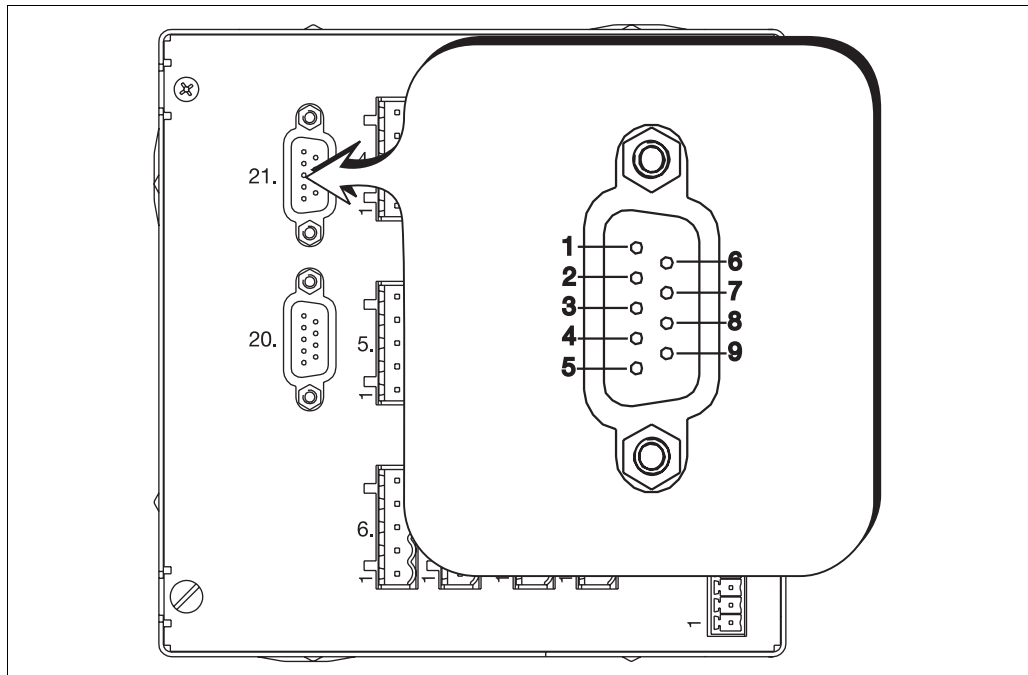

Connector 21

Interface

Connection diagram

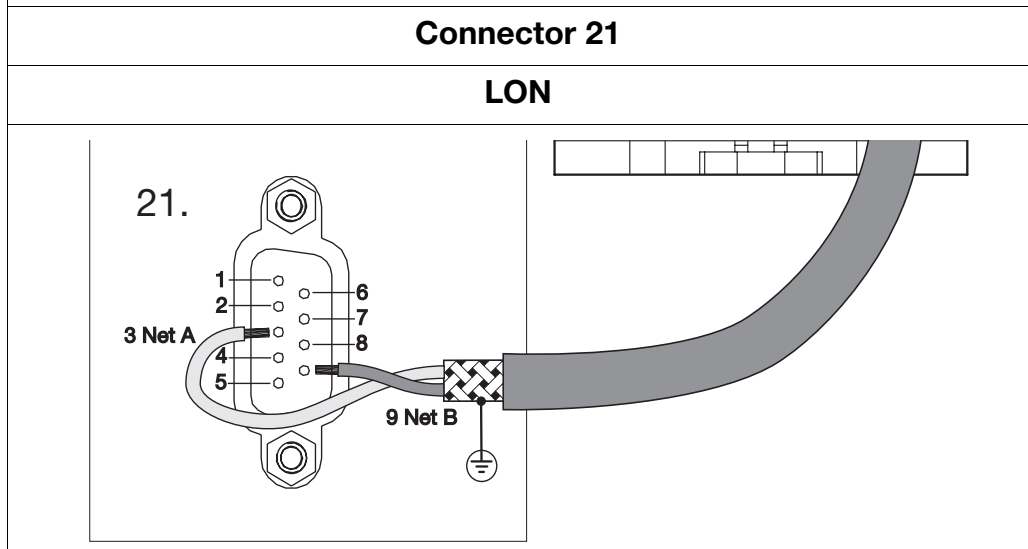

The screen recorder is connected to the modules of the “JUMO mTRON automation system” series using the connections Net_A and Net_B. The technical details are described in the corresponding installation instructions for the mTRON modules. Further information on bus termination can be taken from the Section 3.2 “Connecting configured mTRON modules”.



When connecting the LON interface, care must be taken not to mix up connectors 20 and 21. Connector 20 is reserved for the serial interface. Measurements, as well as instrument and process data, can be read out from the screen recorder with the aid of the serial interface. The connection and functionality of the serial interface are explained in detail in the Interface Description B 70.6560.2.0.

3 Connecting the interface

3.2 Connecting configured mTRON modules

The mTRON modules are connected to the screen recorder using a screened twisted pair. The pre-configured mTRON modules are labelled according to customer specification.

Example: 1 screen recorder and 2 analogue input modules

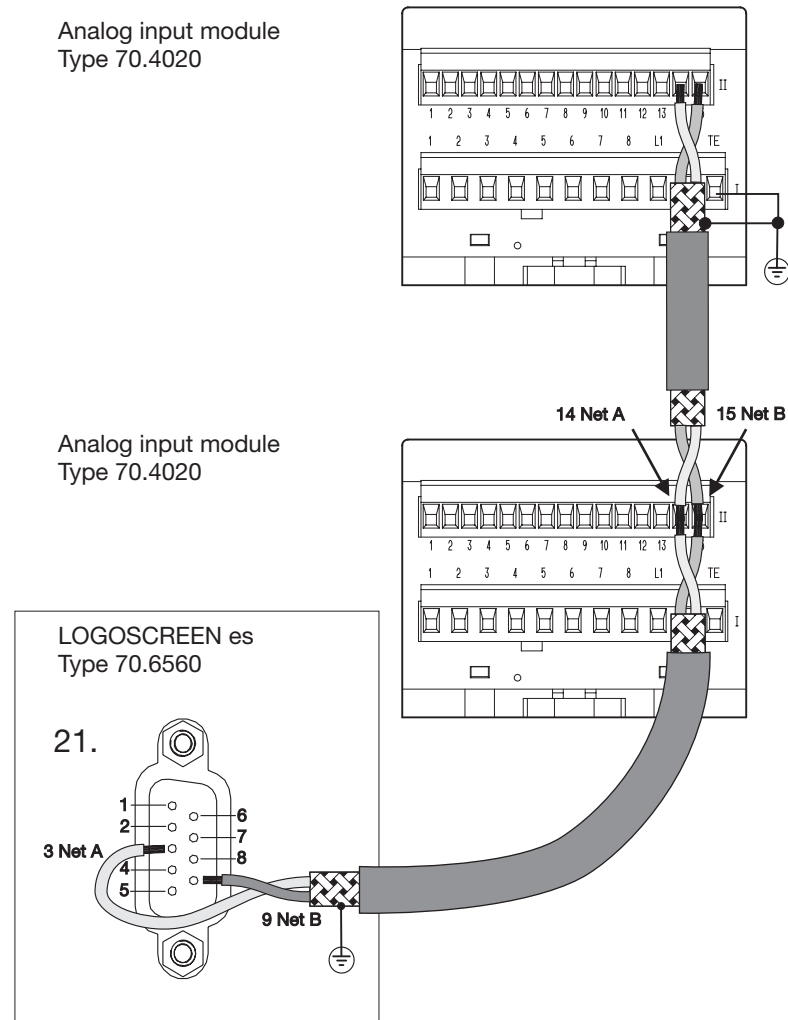

In the example shown, two analogue input modules are connected to the screen recorder in the “line structure” type of connection. The physical ends (screen recorder and module 2) must be fitted with a termination resistor.

The bus termination resistor (50Ω) of the screen recorder is activated through a wire link between pin 4 and pin 8 (see Section 3.1 “Connection diagram”).

Further details on the bus termination of the analogue input modules can be obtained from the installation instructions for the modules.

4 Operation and visualisation

4.1 Instrument info

Two function keys are available in the screen recorder menu *Instrument info* that can be used for communication and service purposes.



“Wink” message

A “Wink” message causes all the connected mTRON modules to flash their service LEDs for 10 seconds at one second intervals (display “Wink received” on the operating unit 70.4035). This function enables the identification of mTRON modules which are not contacted by the screen recorder.



Independently of the “Wink” function, the service LED of an mTRON module flashes if a fault occurs in the module. The blink characteristics of the mTRON module are described in the corresponding installation instructions.

Service

The “service-pin message” is only required with simultaneous use of the JUMO mTRON-iTOOL project design software. Using this function, the position of the screen recorder that is connected can be determined within iTOOL and reported (“joining”).

4 Operation and visualisation

4.2 External analogue inputs

The external analogue inputs which are connected are configured in the screen recorder menu *Configuration* → *Analogue inputs*. One of the menu entries “External input 1 – 24” or “External counter 1 – 2” has to be selected for this purpose.

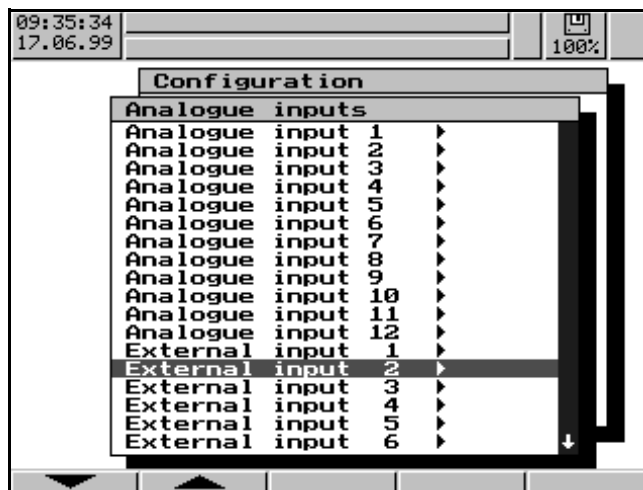

After an external input has been selected, its configuration menu will appear on pressing the **ENTER** key.



Only the parameters “Scaling start”, “Scaling end” and the sub-menu “Additional parameters” are available here. All other parameters for the mTRON modules are either pre-configured ex-factory to customer specification, or have to be altered using the JUMO mTRON-iTOOL project design software. The parameters which are available are described in detail in the Operating Instructions B 70.6560.0.

Sampling cycle

The external analogue inputs are registered by the screen recorder with a maximum delay of 1 second.

4 Operation and visualisation

4.3 External logic inputs

The menu *Configuration* → *Digital signal name* is available for the external logic inputs which are connected.

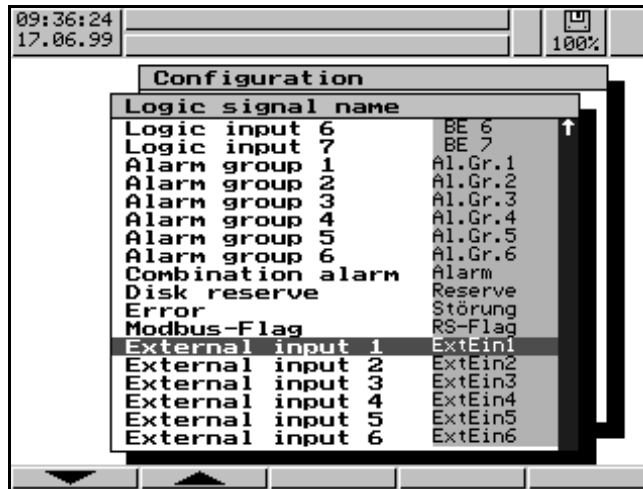

After selecting the menu entry “External input 1 – 6” and subsequently pressing the **ENTER** key, a character string can be entered that will identify the input. This identification is shown in different graphical representations on the screen recorder.

Sampling cycle The external logic inputs are registered by the screen recorder with a maximum delay of 1 second.

4.4 External counters

The two inputs (external counters 1 – 2) are a special feature. They are intended for connection to the counter outputs of two mTRON analogue input modules. Each counter contains the result of a hardware pulse counter of the Neuron firmware for two cycles of the mTRON analogue input module (one cycle = 420msec) and has 16 bit (without sign). Up to 65535 pulses in 840msec can be counted in this way.

The counters are configured via the menu *Configuration* → *Operating functions* → *Counters*.

4 Operation and visualisation

4.5 Group configuration

In the screen recorder menu *Configuration* → *Grp configuration*, the inputs that are externally connected are assigned to screen recorder groups.

	Parameter	Value/selection	Explanation
Analogue channels	Configuration → Grp configuration → Group 1 – 6 → Analogue channels → Analogue channel 1 – 6 → Input signal	Off, Analog inp1 – 12, Ext. inp. 1 – 24, Counter 1, Counter 2 Ext. counter 1, Ext. counter 2	Assignment of the hardware inputs (internal and external) to the channels of the group
Digital channels	Configuration → Grp configuration → Group 1 – 6 → Digital channels → Digital channel 1 – 3 → Input signal	Off, Logic inp.1 – 7, Alarm gr.1 – 6, Comb. alarm, Disk reserve, Error, Modbus flag, Ext. Inp. 1 – 6	Assignment of the hardware inputs (internal and external), or of the signals generated by software, to the digital channels of the group.

5 JUMO mTRON-iTOOL project design software

This chapter contains all the information necessary to establish a connection between the screen recorder and the mTRON modules, using the JUMO mTRON-iTOOL project design software .

The data between the screen recorder and the mTRON modules are exchanged via LON network variables (NVs) which are “bound” with the aid of the iTOOL project design software. The same conditions apply (bus transfer parameters) as for all mTRON modules. For further information, please refer to the mTRON system manual.

5.1 Establishing a network connection

The setup interface of an mTRON module is used to provide the connection between the PC (iTOOL) and the mTRON modules. As long as a module is used for configuration purposes (setup connector plugged-in), it is not active. All the other mTRON modules continue to operate unchanged during configuration .



The setup interface of the screen recorder can **not** be used for this purpose; it is reserved for the setup program.

5.2 Input network-variables

Values and operating signals from other modules can be transferred to the screen recorder via the network through the input network-variables.

List of input network variables



Name	Type	Explanation
Bool_In01 . . . Bool_In06	logic	The “external logic inputs” of the screen recorder are provided via these variables. ⇒ Section 4.3 “External logic inputs”
Real_In01 . . . Real_In24	float value	The “external analogue inputs” of the screen recorder are provided via these variables. ⇒ Section 4.2 “External analogue inputs”
Counter_In01 Counter_In02	long	The “external counters” of the screen recorder are provided via these variables. ⇒ Section 4.4 “External counters”

Transfer rate

All “bound” network variables are transferred within a maximum of one second.

5 JUMO mTRON-iTOOL project design software

5.3 Output network-variables

The internal analogue and logic inputs, as well as the two counters of the screen recorder, can be transferred via the network to other modules, using the output network-variables. In conjunction with a logic module (70.4030), for example, eight measurement inputs can thus be logically linked.

List of output network-variables

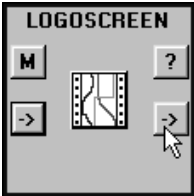

Name	Type	Explanation
Bool_Out01 . . . Bool_Out06	logic	The “internal logic inputs” of the screen recorder can be accessed via these variables.
Real_Out01 . . . Real_Out12	float value	The “internal analogue inputs” of the screen recorder can be accessed via these variables.
Counter01 Counter02	float value	The “internal counters” of the screen recorder can be accessed via these variables.

Transfer rate

All “bound” network variables are transferred within a maximum of one second.

5.4 Parameter setting

Basic menu

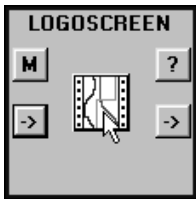

Module name
Name of the module

Setup dialog
The functions of the module are assigned to setup dialogs

OK
for entering and storing all inputs

Cancel
for aborting inputs.
The data are not stored.

Edit
for editing parameters in the setup dialog which is marked

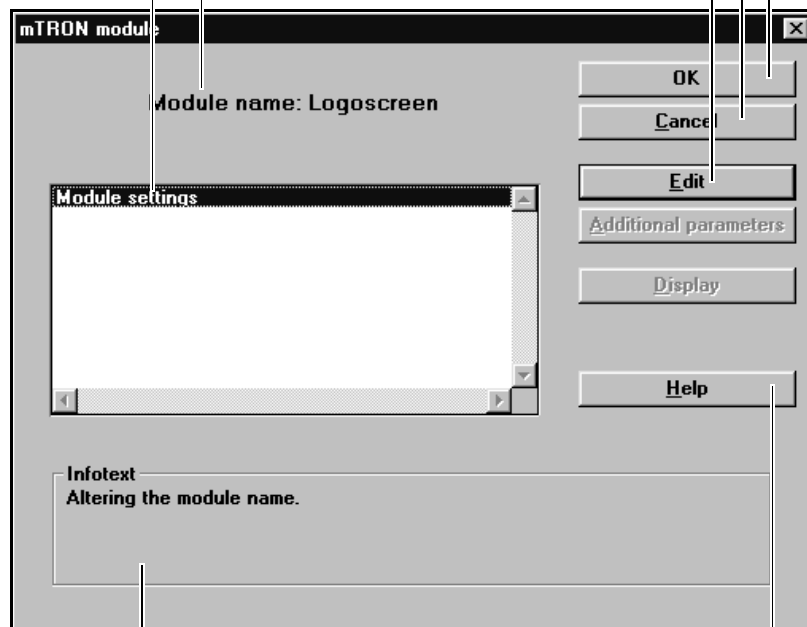

Info text
provides information on the setup dialog which is marked

Help
calls up the help text for the basic menu

5 JUMO mTRON-iTOOL project design software

5.4.1 Module settings

A characteristic designation for the screen recorder is provided here. Through assignment of a module name, for example, several screen recorders which are connected to the system can be differentiated more easily.

Setup dialog

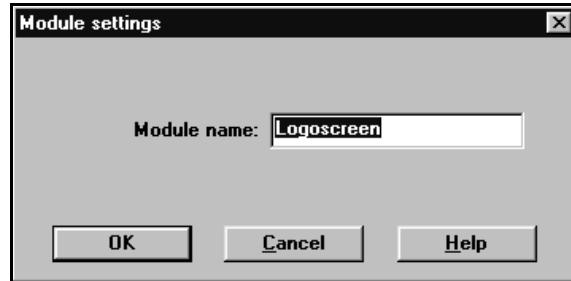

Parameter

Parameter	Selection/settings	Explanation
Module name [16 characters]	LOGOSCREEN	Name of the module (16 characters)

■ = factory setting [] = short name in the operating unit

Further setup dialogs are not available for the screen recorder. All the other settings for the screen recorder have to be made either through its setup program, or from the instrument keys.



By assigning different module names, several screen recorders can be operated in one LON network.

5.5 mTRON modules

All available mTRON modules can be linked to the screen recorder.

5.5.1 mTRON operating unit

If an mTRON operating unit is connected to the LON network, it can be used to read all the network variables (except the input counter) at the "current module data" level.

5.5.2 Communication module

The communication module enables remote monitoring of the screen recorder and the mTRON modules. The addresses required for establishing a connection to the screen recorder using the communication module are described in the "JUMO mTRON communication module" system manual. All the network variables (except the input counter) of the screen recorder can be addressed.

5 JUMO mTRON-iTOOL project design software

5.6 Project design example

The JUMO mTRON-iTOOL project design software must be used if no configured mTRON modules are available, or if these have to be reconfigured.

When operating the software it is essential to follow a defined path.

- Selection of the software module
- Configuration of the mTRON modules
- Selection of the software inputs/outputs
- Transfer of project

Selection of the software modules

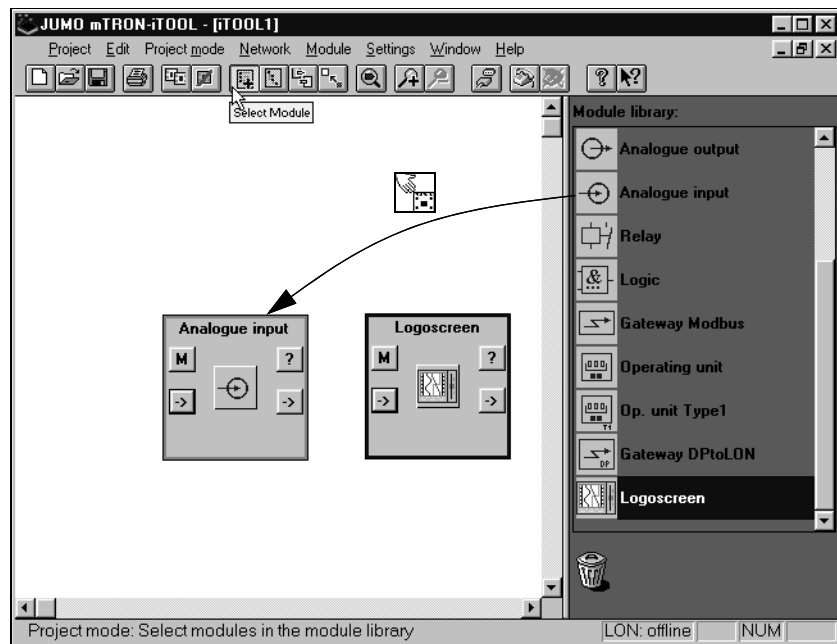



The modules available in the module library can be dragged into the working area by keeping the left mouse button pressed down (drag & drop). Each module can subsequently have a name assigned.

5 JUMO mTRON-iTOOL project design software

Configuring the mTRON modules

In order to connect a temperature probe to an mTRON module, this module has to be configured.

This is done by clicking on the  button with the left mouse button. A dialog window appears in which first the entry *Analogue input* (1) is selected, and then the  function (2) is called up.

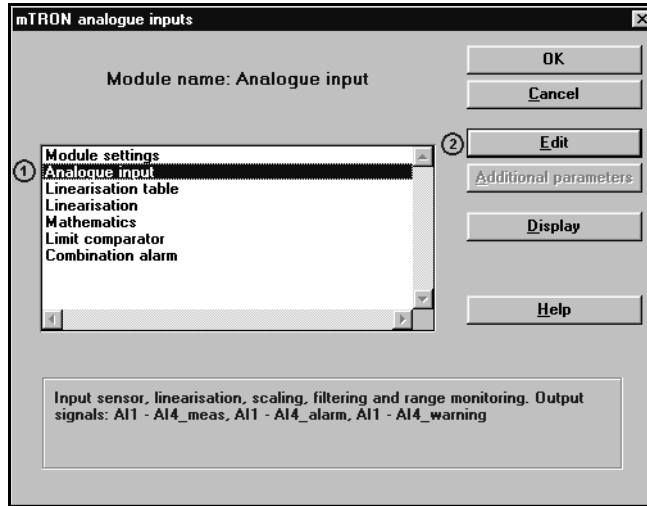

In the dialog window which now opens, the required input can be configured.

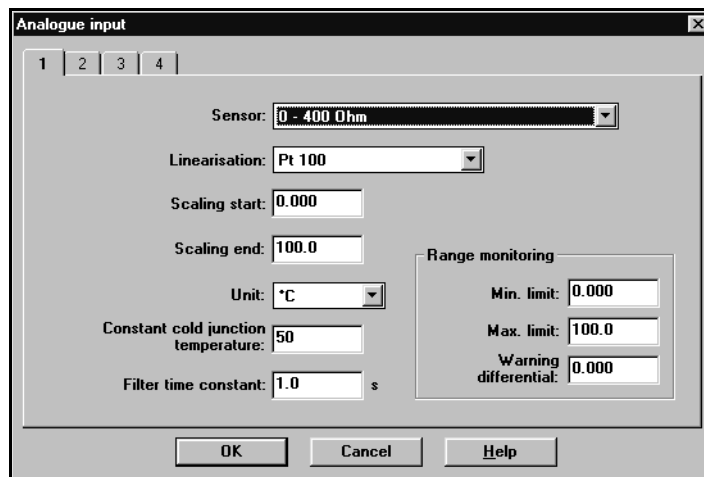



Confirm the entry by pressing the  key.

5 JUMO mTRON-iTOOL project design software

Selecting the software inputs/outputs

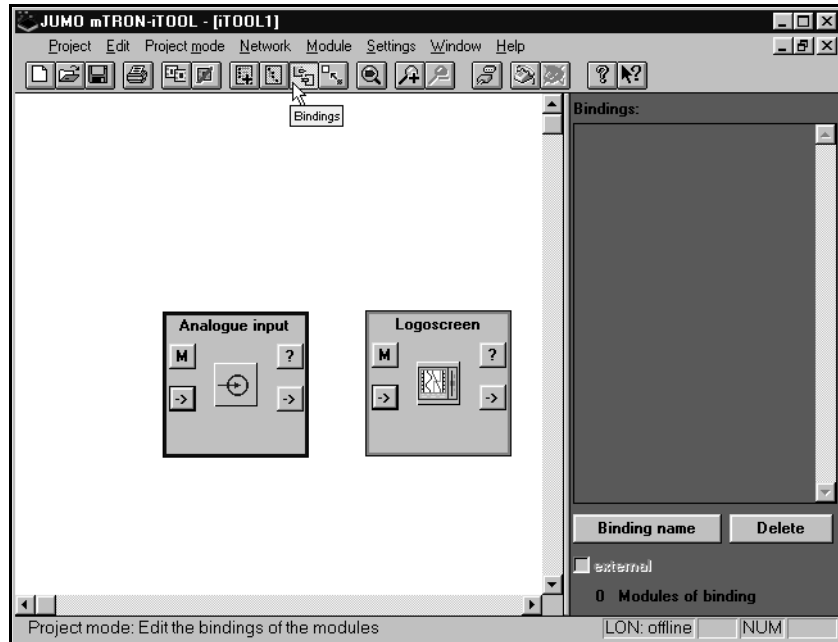
After the analogue inputs have been successfully configured, the software inputs and outputs are selected. To do this, it is necessary to change to the bindings level.



Afterwards all available inputs/outputs are made visible on the screen using the buttons  (analogue input) and  (Logoscreen).

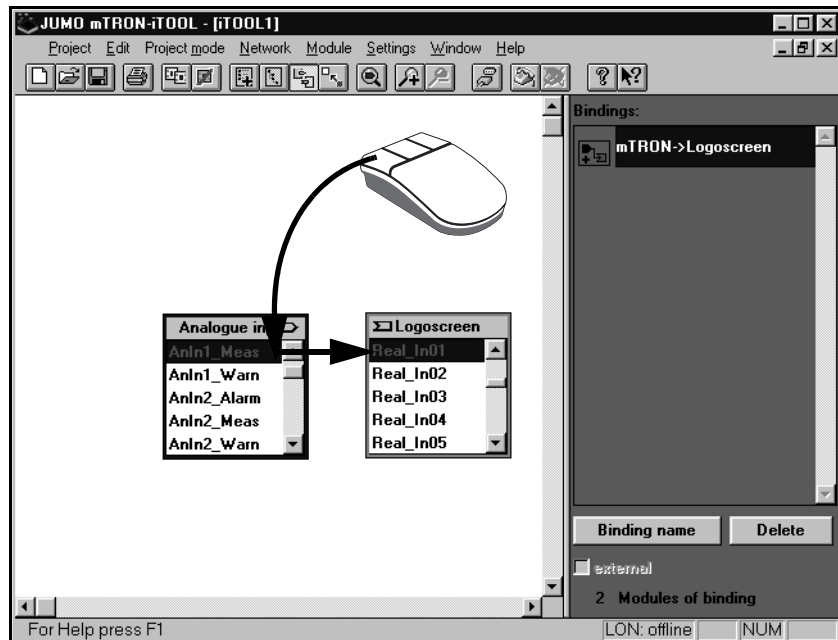





The bindings between input and output are made with the mouse (keep left mouse button pressed down). The binding can be identified by a name which can be selected.

5 JUMO mTRON-iTOOL project design software

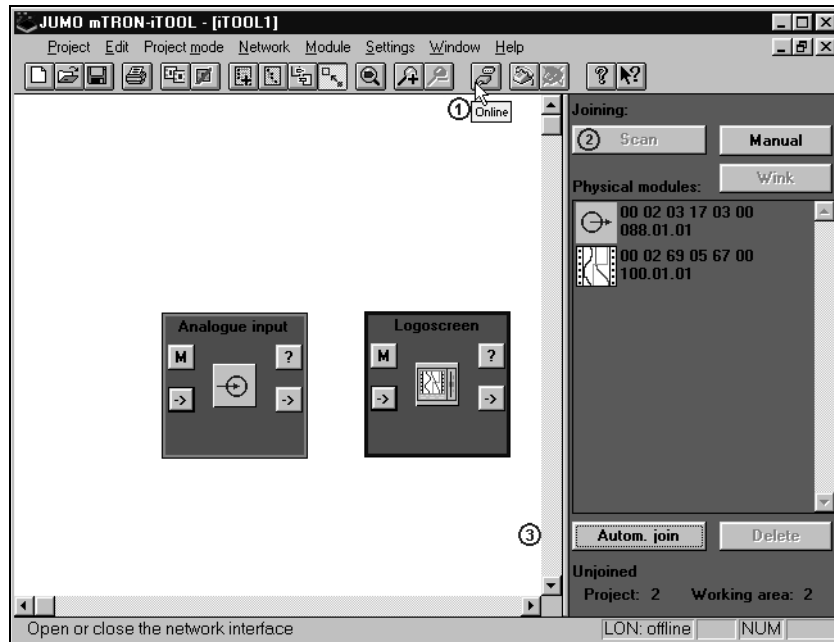
Transfer the project

The following steps have to be carried out before all settings can be transferred from the project design software to the screen recorder and the mTRON modules.

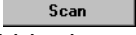

1. The button  is used to establish the on-line connection to the modules.
2. Using the  button, all modules that are physically available are entered within the project design software.
3. The button  is used to assign the modules that are physically available to the software modules.

The project can now be transferred to the modules. The menu *Network* is available for this purpose.

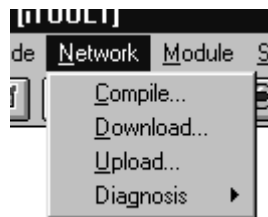

A check has first to be carried out using the function *Network* → *Compile*. Only when the check has been successfully completed, can the project be transferred to the individual modules with the aid of the *Network* → *Download* function.

6.1 Response after a power failure

After the supply voltage has been restored and the subsequent initialisation phase completed, all network-variables are reset to the correct values. The input and output counters continue to operate with the values present at the time of the power interruption.

6.2 Response on failure of mTRON module

When the screen recorder recognises the failure of an mTRON module (within a maximum of 20 seconds after the failure) which provides values for its input network-variables, it triggers the “Error” event. Measurements are designated “no measurement” (display “-----”), counters are assigned the value 0 and logic inputs the value FALSE. In addition, the info symbol flashes and in the menu *Instrument info* → *Error* the message “Ext. input” appears.

Within a maximum of 10 seconds after rectifying the error, the alarm should cease to be present within the screen recorder and the exchange of data should function again.



mTRON modules which have failed can only be recognised when there is at least one network-variable binding between them and the screen recorder.

6 Error handling



JUMO GmbH & Co. KG

Street address:
Moltkestraße 13 - 31
36039 Fulda, Germany
Delivery address:
Mackenrodtstraße 14
36039 Fulda, Germany
Postal address:
36035 Fulda, Germany
Phone: +49 661 6003-0
Fax: +49 661 6003-607
e-mail: mail@jumo.net
Internet: www.jumo.net

JUMO Instrument Co. Ltd.

JUMO House
Temple Bank, Riverway
Harlow, Essex CM20 2TT, UK
Phone: +44 1279 635533
Fax: +44 1279 635262
e-mail: sales@jumo.co.uk
Internet: www.jumo.co.uk

JUMO Process Control, Inc.

8 Technology Boulevard
Canastota, NY 13032, USA
Phone: 315-697-JUMO
1-800-554-JUMO
Fax: 315-697-5867
e-mail: info@jumo.us
Internet: www.jumo.us