

LOGOPRINT[®] 500 junior

Printing recorder
with text printing and
LED dot-matrix display

B 95.4013
Operating Manual

01.04/00362729

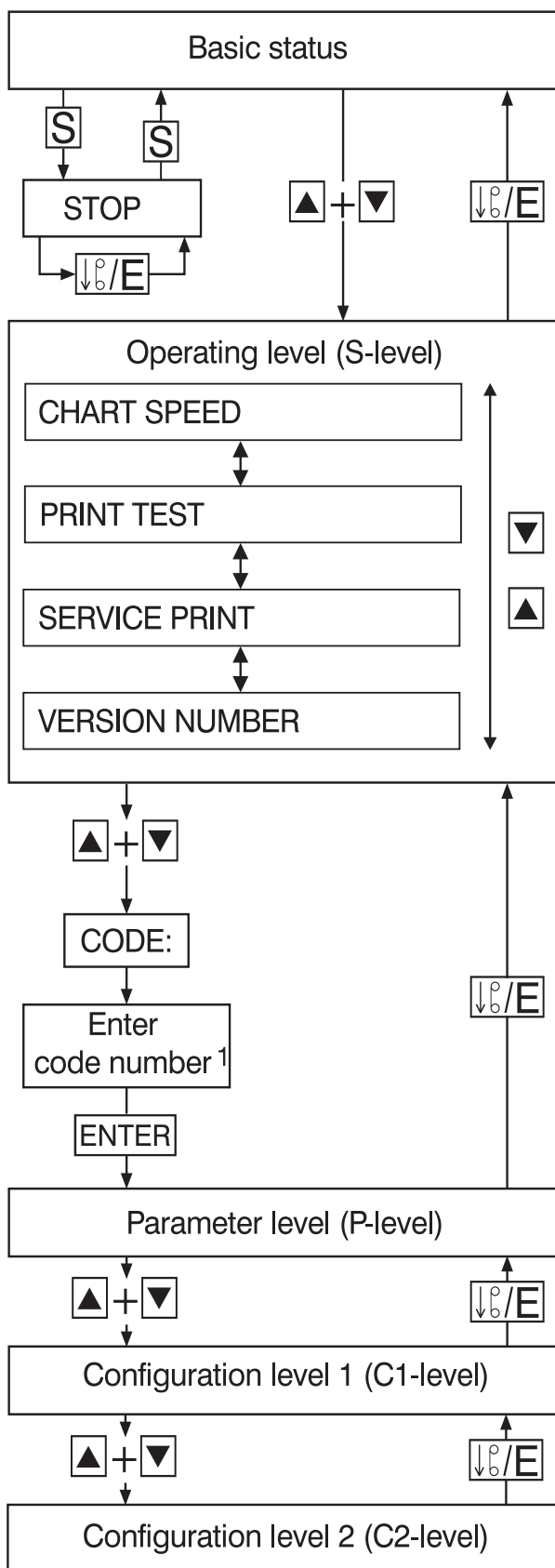

Key functions

↓p/E	<ul style="list-style-type: none"> - Paper (chart) fast-forward when recording is stopped (in basic status) - Abort parameter entry (Exit) - Leave the levels
S	<ul style="list-style-type: none"> - Start/stop recording - Selection of decimal place when entering values - For text entry: Fast character selection (jump to “ ”, “0”, “A”, “a”, “o”, “2”, “À”, “à”)
F	<ul style="list-style-type: none"> - Function key for special functions (press for at least 4 sec) <p>factory setting: print the scaling</p>
◀, ▶	<ul style="list-style-type: none"> - Shift cursor left/right (selecting position)
▲, ▼	<ul style="list-style-type: none"> - Select display: <ul style="list-style-type: none"> - instrument name, date & time - channel measurements - system states - Parameter selection - Channel selection - Value selection from a table of values - Increment/decrement present digit
ENTER	<ul style="list-style-type: none"> - Initiate parameter entry - Confirm entry - Acknowledge error message - Activate/de-activate static display (in basic status)
◀ + ▶	<ul style="list-style-type: none"> - Activate/de-activate display of status/error messages
▲ + ▼	<ul style="list-style-type: none"> - Change to next level

1. Code number: 9200

1	Introduction	7
1.1	Preface	7
1.2	Arrangement of the documentation	8
1.2.1	Structure of this operating manual	8
1.3	Typographical conventions	9
1.3.1	Warning signs	9
1.3.2	Note signs	9
1.3.3	Presentation	10
2	Instrument description	11
2.1	Display and controls	11
2.2	Principle of operation	12
3	Operation and visualisation	21
3.1	Graphics print-out	21
3.2	Text printing	23
3.2.1	Printing priorities	23
3.2.2	Switching the chart speed	24
3.2.3	“Power on” and “Power off” text	24
3.2.4	Scaling	24
3.2.5	Time	26
3.2.6	Print out channel numbers	27
3.2.7	Recording start and stop	27
3.2.8	Print test	28
3.2.9	Service print	29
3.3	Colour assignment	30
4	Configuration table	31
4.1	Operating examples	31
4.2	Table of the configuration parameters	33
4.2.1	Operating level (S-level)	33
4.2.2	Parameter level (P-level)	34
4.2.3	Configuration level 1 (C1-level)	35
4.2.4	Configuration level 2 (C2-level)	36

Contents

5	Identifying the instrument version	39
5.1	Instrument description	39
5.2	Ordering details	40
6	Installation	41
6.1	Location and climatic conditions	41
6.2	Assembly in a control panel	41
7	Electrical connection	43
7.1	Installation notes	43
7.2	Technical data	44
7.3	Connection diagram	46
7.4	Isolation	47
8	Starting up	49
8.1	Opening and closing the door	49
8.2	Marking the channel label	49
8.3	Fitting the print head	50
9	Consumables	51
9.1	Consumables	51
9.2	Removing and replacing the chart cassette	52
9.2.1	Changing the roll chart	53
9.2.2	Changing the fanfold chart	54
10	Accessories	55
10.1	Converting the chart cassette	55
11	Fault finding	57
11.1	What to do if	57

Contents

12	Appendix	59
12.1	Error messages	59
12.2	Hardware fault	60
12.3	Status messages	61
12.4	Character set	62
12.5	Summary of the parameters	63
13	Index	65

Contents

1.1 Preface



Please read this Operating Manual before commissioning the instrument. Keep the operating manual in a place which is accessible to all users at all times.

Please assist us to improve this manual, where necessary.

Your suggestions will be appreciated.

Phone in Germany (0661) 6003-725
from abroad (++49) 661 6003-0
Fax in Germany (0661) 6003-681
from abroad (++49) 661 6003-607



All the necessary settings are described in this manual. However, if any problems should still arise during start-up, you are asked not to carry out any unauthorised manipulations. You could endanger your rights under the warranty!

Please contact the nearest JUMO office or the main factory.



When returning chassis, modules or components, the regulations of EN 100 015 “Protection of electrostatically sensitive devices” must be observed. Use only the appropriate **ESD** packaging for transport.

Please note that we cannot be held liable for any damage caused by ESD (electrostatic discharge).

1 Introduction

1.2 Arrangement of the documentation

The documentation of this instrument consists of the following parts:

**Operating
Manual
B 95.4013**

This operating manual is supplied with the instrument. It is addressed to OEMs (original equipment manufacturers) and users with the appropriate technical expertise.

In addition to installation and electrical connections, it also includes information on commissioning, operation, and setting the parameters in the instrument, on extra codes and accessories.

1.2.1 Structure of this operating manual

This operating manual is laid out so that the user is immediately able to get on with operating and configuring the instrument. To this end, the chapters which describe procedures that are usually carried out once, such as description of the instrument, type designation, installation and electrical connections, are placed at the end of the manual.

1.3 Typographical conventions

1.3.1 Warning signs

The signs for **Danger** and **Warning** are used in this manual under the following conditions:



Danger

This symbol is used where there may be **danger to personnel** if the instructions are disregarded or not followed accurately!



Warning

This symbol is used where there may be **danger to equipment or data** if the instructions are disregarded or not followed accurately!



Warning

This symbol is used where special care is required when handling **components which are liable to damage from electrostatic discharge**.

1.3.2 Note signs

Note



This symbol is used when your attention is drawn to a **special remark**.

Reference



This sign refers to **further information** in other manuals, chapters or sections.

Footnote

abc¹

Footnotes are notes which **refer to** certain points in the text. Footnotes consist of two parts:

Marking in the text and the footnote text.

The markings in the text are arranged as continuous superscript numbers.

Action

*

This symbol shows that an **action to be performed** is described.

The individual steps are designated by the asterisk, for example:

* Press the  key

* Confirm with 

1 Introduction

1.3.3 Presentation

Keys

▲ + ENTER

Keys are **shown in a box**. Both **symbols and texts** are possible. If a key has multiple functions, then the text shown is that which corresponds to the **currently active function** .

Menu items

*Edit →
Instrument data*

The menu items in the setup program which are referred to in this manual are shown in italic script. Menu name, menu item, and sub-menu item are separated from one another by “→”.

2 Instrument description

2.1 Display and controls

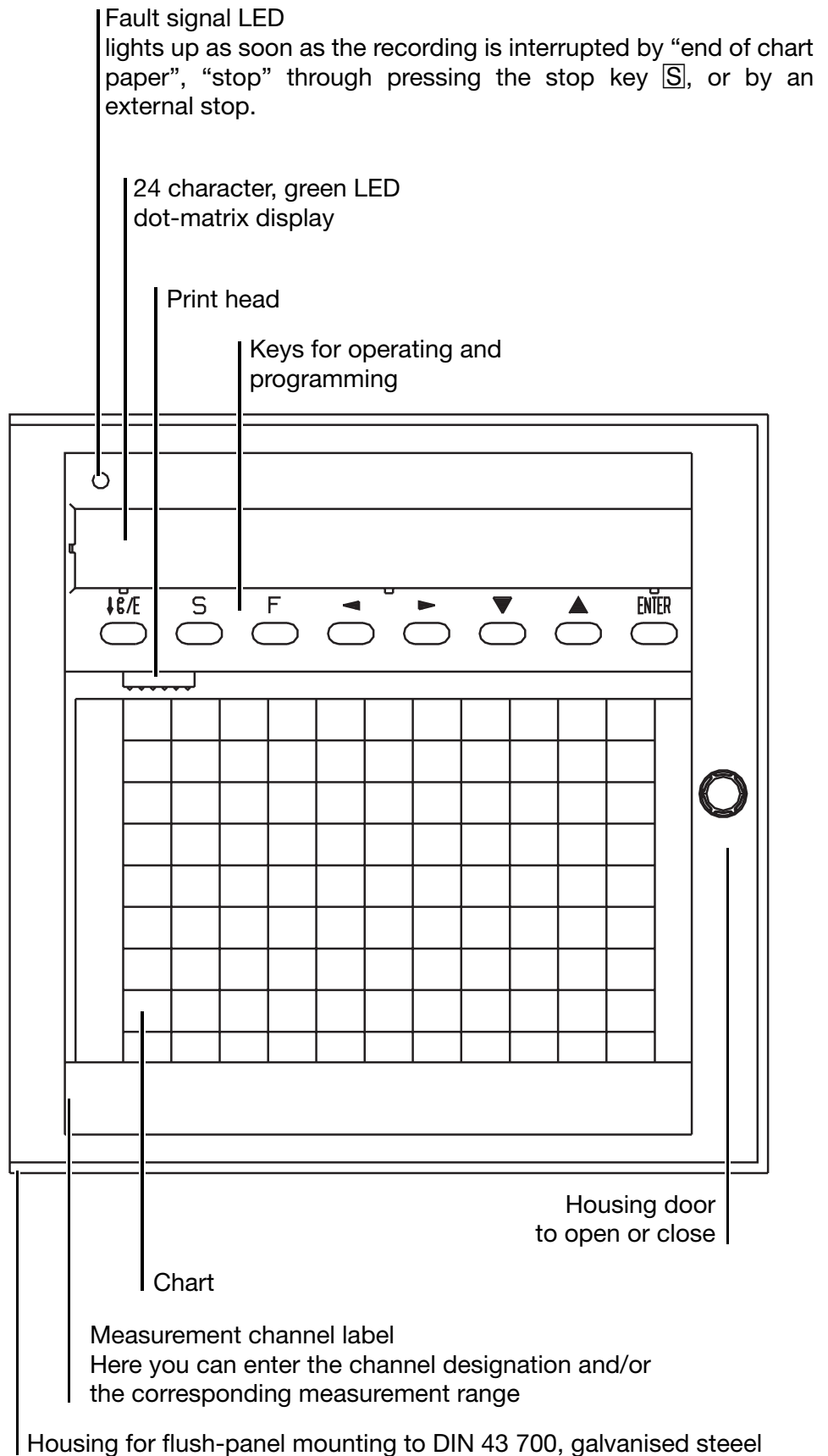

2 Instrument description

2.2 Principle of operation

In order to keep the operating and programming of the printing recorder clear and simple, the individual parameters and functions are divided into several levels:

- Basic status
- Operating level (S-level)
- Parameter level (P-level)
- Configuration level 1 (C1-level)
- Configuration level 2 (C2-level)

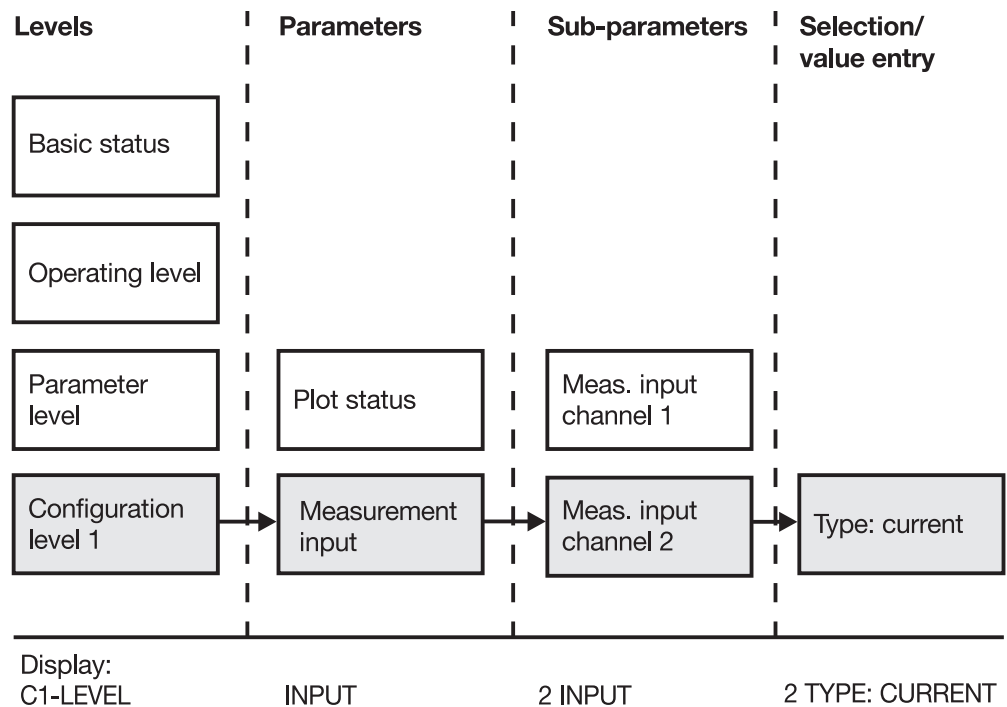

The levels, parameters and sub-parameters are arranged as a tree structure. Starting from the basic status, it branches out into the individual levels, and from there further into the corresponding parameters and, if available, sub-parameters.













If it is necessary to change a specific parameter, then step through the relevant level until this parameter is reached.

Pressing **ENTER** starts the editing process.

If a parameter has several sub-parameters, these can also be accessed by pressing **ENTER**.

2 Instrument description

Key functions

	Basic status	Operating level	after correct code number in parameter and configuration levels
 /E	Chart fast-forward, when recording is stopped	-Abort parameter entry (Exit) -Leave the level	-Abort parameter entry -Leave the level
 S	Start/stop recording mode	Start/stop recording mode	Step -for values: select the decimal place -for texts: fast character selection: jump to “ ”, “0”, “A”, “a”, “o”, “2”, “À”, “à”
 F	Function key (reserved for special functions) ¹	Function key (reserved for special functions)	-----
 , 	-----	-----	Shift cursor to left/right (select place)
 , 	Select display: - instrument name, date & time - channel measurements - system states	-Select parameter -Select channel -Select value from table -Enter numbers: change the place selection	-Parameter selection -Channel selection -Select value from table -Enter text/numbers: change the place selection
 ENTER	Change-over between cyclic and static display	-Initiate the parameter entry -Confirm the entry -Acknowledge any error messages	-Initiate the parameter entry -Confirm the entry -Acknowledge any error messages
Key combinations:			
 + 	Activate/de-activate display of status/error messages	-----	-----
 + 	Change to next level	Change to next level	Change to next level

1.  key (press for at least 4 sec) in the standard version: print out the scaling of all the active channels (plot status = ON).

2 Instrument description

For all alterations to the parameters (sub-parameters):

Confirming parameters

If there is no further sub-parameter, then **ENTER** transfers all the data which belong to the parameters into the memory.

Aborting programming

Inside a parameter, programming can be abandoned by pressing the **↓/E** key.



If the last sub-parameter has not yet been confirmed, then the data which were already edited for the parameter will be abandoned. The old values for the sub-parameters will be retained.

Error messages during programming

If error messages occur during programming, as a result of erroneous entries, then the messages must be acknowledged with **ENTER** before the programming can be taken up again.

Selection

A selection consists of a list of several options:

Three keys are used to select an option:

- * Select the option with the **▲** and **▼** keys
- * Confirm the selection with **ENTER**

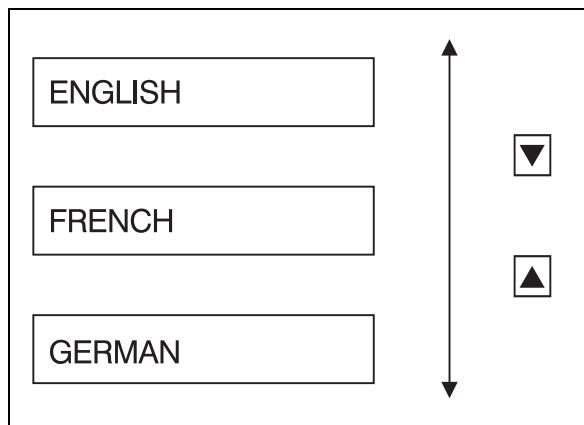

2 Instrument description

Value/text entry

Five keys are used to enter values:

- * select the position to be altered with the ◀ and ▶ keys
- * increment and decrement the selected position with the ▲ and ▼ keys
- * move the decimal point with the S key
- * confirm the value entered with ENTER

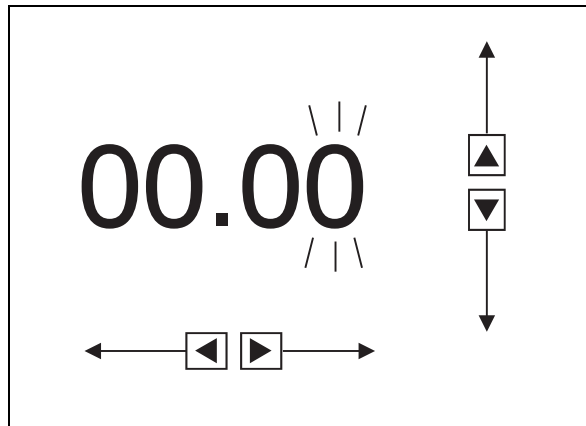

An erroneous entry will cause an error message in the display

⇒ Section 12.1 “Error messages”

The error message must be acknowledged with ENTER.

Afterwards, a new value can be entered.

Five keys are used to enter texts:

- * select the character to be altered, using the ◀ and ▶ keys
- * select the new character with the ▲ and ▼ keys
(fast character selection with the S key)
- * confirm the text entry with ENTER

2 Instrument description

Basic status

After the supply voltage has been applied, the printing recorder will be initialised and is then in the basic status. Measurements are acquired, processed and recorded.

The 24-character LED dot-matrix shows:

- instrument name, date and time (the time can be switched off via the parameter *S-level* → *Display time*)
- channel numbers and measurements (incl. units) of all active channels (in pairs)
- channel number, designation and measurement (incl. units) of all active channels (in sequence)
- status and error messages

The display can be either cyclic or static:

Cyclic display

The printing recorder switches automatically to the next display after about 3 sec.

Static display

The static display is activated and de-activated with **ENTER**. If it is activated, then the present display remains, and is regularly updated.

In the basic status, the information on the display can be changed over with the **▲** and **▼** keys.

Status/error messages will be identified in plain language by a regularly flashing display instead of the present display.

The display of status/error messages can be inhibited, or activated again, by pressing **◀** + **▶**.

If a measurement is outside the valid measurement range, the character combination “>>>>>” will appear instead of the value.

Recording can be stopped, or re-started, with the **S** key. In the stop status “STOP” will flash in the LED dot-matrix display.

Using the **⏏/E** key, in the stop status, activates the chart fast-forward.

Pressing the **F**-Taste for at least 4 sec will start the scaling print.

The operating level can be accessed by pressing the **▲** + **▼** keys simultaneously.

2 Instrument description

Example of the basic status for a 6-channel recorder

BUILDING28 26.08.98 08 : 54	Display instrument name, date and time
▲ ▼	
1 -5.321 m/h 2 +34.67 °C	Display the first 2 channels in one frame
▲ ▼	
3 +76.20 °C 4 +20.35 bar	Display the next 2 channels in one frame
▲ ▼	
5 +35.08 °C 6 +007.4 U/m	Display the next 2 channels in one frame
▲ ▼	
1 CONVEYOR -5.321 m/h	Display 6 channels, each in a separate frame
▲ ▼	
2 MIXER +34.67 °C	
▲ ▼	
3 MOT7. BEARING +76.20 °C	
▲ ▼	
4 PRESSURE +20.35 bar	
▲ ▼	
5 VENT.TEMP. +35.08 °C	
▲ ▼	
6 SHAFT +007.4 U/m	

Operating level (S-level)

The operating level can be accessed from the basic status, using the ▲ + ▼ keys, from the parameter level with $\downarrow \uparrow / E$.

Signal acquisition and processing remain active at this level.

The following parameters can be altered:

- chart speed
- print test
- service print
- version number (display only)



If the operating level is active, then signal acquisition, processing and recording will continue to be performed.

2 Instrument description

Parameter level (P-level)

The parameter level can be accessed from the operating level using the ▲ + ▼ keys, from the configuration level 1 with ↓↵/E.

The parameter level and the configuration levels are protected by a 4-digit code number (9200).

If the correct code number is entered, then

- signal acquisition and
- recording

will be interrupted.

The parameters can now be programmed.



If a wrong code number is entered, then the recorder will remain in normal operation. Signal acquisition, processing and recording are still active.

The parameters can be viewed, but not programmed.

After a valid code number has been entered, the following parameters can be altered at the parameter level:

- language
- date & time
- summer time
- display brightness
- time display

Configuration level 1 (C1-level)

Channel-specific parameters can be configured at configuration level 1. This level can be accessed from the parameter level by using the ▲ + ▼ keys, from the configuration level 2 using ↓↵/E.



If a correct code number was entered when calling up the parameter level, signal acquisition and recording will be interrupted at this level. The parameters can be viewed and altered.

Configuration level 1 contains the following channel-specific parameters:

- plot status
- measurement input
- scaling
- channel designation

2 Instrument description

Configuration level 2 (C2-level)

Configuration level 2 can be accessed from configuration level 1 by using the ▲ + ▼ keys.



If a correct code number is entered when calling up the parameter level, then signal acquisition and recording will be interrupted at this level. The parameters can be viewed and altered.

Configuration level 2 contains the following global parameters:

- instrument name
- print-out of speed change
- print-out of “power on” text
- print-out of “power off” text
- scaling print
- time print
- print channel number
- start text
- end text
- presetting

2 Instrument description

3 Operation and visualisation

The printing recorder has a large variety of possibilities for presenting the measurements acquired at the signal inputs as an informative record on the chart, for monitoring them, and for control.

Functions are available for:

- graphics print-out
- text printing

3.1 Graphics print-out

The printing recorder is fitted with a print head which has 6 colour pens (violet, red, black, green, blue, brown). The printing of measurements and texts is always made in the same direction (unidirectional).

The time which is needed to print out a line depends on the number of dots to be printed in this line. If the maximum number of dots are printed, then approx. 12 sec are required for one line.

As the chart speed increases, more and more measurements, and so more and more lines, have to be printed. The printer must therefore reduce the time which it needs to try and print a line as the speed increases. These times can be seen in the following table.

Speed (mm/h)	Minimum time per line (sec)
5	288
10	144
20	72
60	24
120	12
240	9
300	6
360	5
600	4.8
720	4

Up to a speed of 120mm/h any line can be printed in the specified time, since there are never more than 12 seconds required. At higher speed, if the time taken to print a line is longer than the value in the table, then this lag is compensated by correspondingly increasing the speed for the next line.

Example:

According to the table, at a speed of 300mm/h the printing recorder attempts to print a line every 6 sec. However, printing the current line took 9 sec. This will be compensated by increasing the speed for the next line by 50%.

3 Operation and visualisation

The printing recorder has been so developed that the printed traces are always as visible as possible. For instance, an alternating print of different colours avoids mixing and wasting colours if the measurements are the same.

Example:

If three traces overlap, then the alternating print pattern ensures that no dot has a multiple print, but is printed alternately for each channel.

three traces overlap

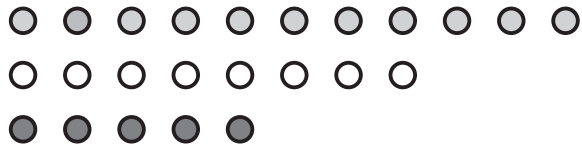

no dot is printed more than once



3 Operation and visualisation

3.2 Text printing

As well as the traces on the chart, the recorder can also print text. Text printing is used for making comments on the traces and for recording events. The characters are printed in dots in a 7 x 9 matrix.

3.2.1 Printing priorities

There are different kinds of text with different priorities. These priorities determine the abort criteria while, at the same time, making text printing requests.

If a text with a low priority is being printed, it will be abandoned if a text with a higher priority is to be printed.

List of priorities

Priority	Text
higher	- Stop by S-key, external stop, no chart, configuration by keys or via setup
	- Print test
	- Service print
	- Start text
	- Text on change of chart speed
	- Scaling by pressing keys
	- Cyclic scaling print and cyclic time print
	- Cyclic print of channel number
lower	

In the following cases, all current requests for text printing will be cancelled and any fresh ones will be ignored:

- Recorder goes into the stop status
- Recorder is switched off

3 Operation and visualisation

3.2.2 Switching the chart speed

Every change of chart speed is recorded by printing out a line with the current time and the new chart speed, if the parameter “Print chart speed” is set to ON (*C2-level* → *Print speed change*).

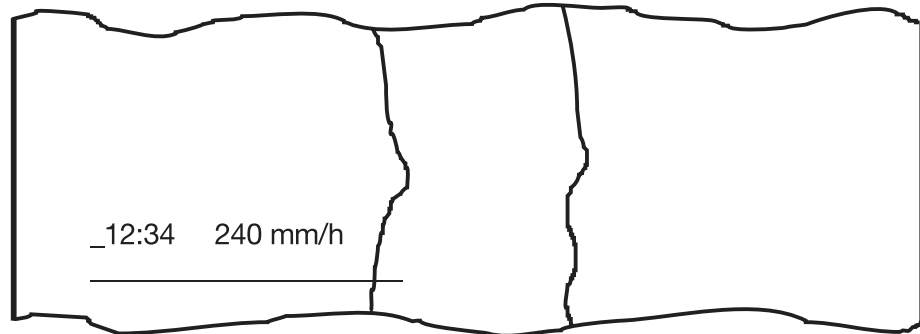

3.2.3 “Power on” and “Power off” text

The time of “Power on” and “Power off” can be documented by using this feature. Both texts are printed in red, with the date and time of the event. The print-out can be inhibited by configuring the parameter *C2-level* → *Print “Power on” text* and *C2-level* → *Print “Power off” text*.

3.2.4 Scaling

The scaling can be printed in two different ways:

cyclic:

for each channel, at a configurable spacing
(*C2-level* → *Print scale*)

triggered:

for all channels, when the **F** key is pressed for at least 4sec

The basic rule is: scaling can only be carried out when the plot status is activated for the corresponding channel.

3 Operation and visualisation

Cyclic scaling print

Selectable spacings:

- approx. 30cm
- approx. 60cm
- approx. 90cm
- switched off

The scaling is printed in the colour selected for the channel. In the bottom line is the programmed channel designation and the unit for the measurement.

In the next line are the scale values for the 0%, 50% and 100% line.

Example:

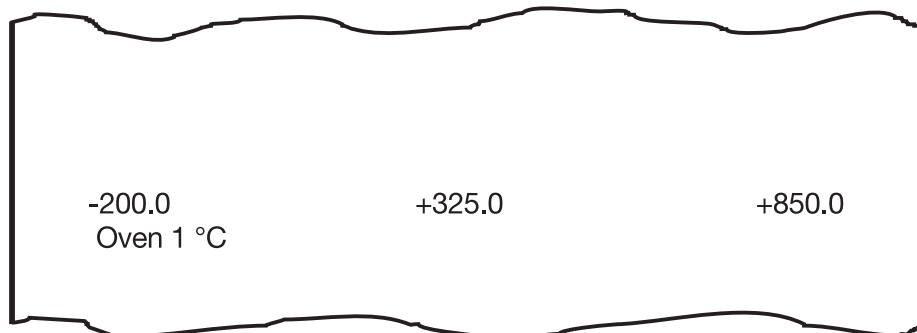

Triggered scaling print

To start the triggered scaling print, the **F** key has to be pressed for at least 4 sec.

The scalings are printed for all channels with an activated plot status. The print-out is arranged in the same way as described for “Cyclic scaling print”.

Example (three channels have been activated):

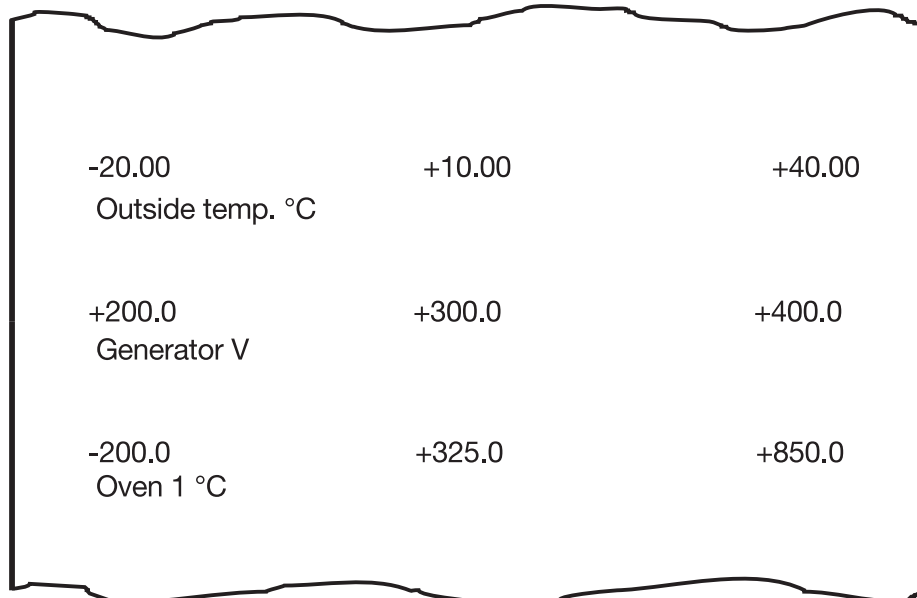

3 Operation and visualisation

3.2.5 Time

The print-out is performed cyclically, at a configurable spacing (*C2-level* → *Print time*).

Selectable spacing:

- approx. 2 cm
- approx. 4 cm
- approx. 6 cm
- no time printing

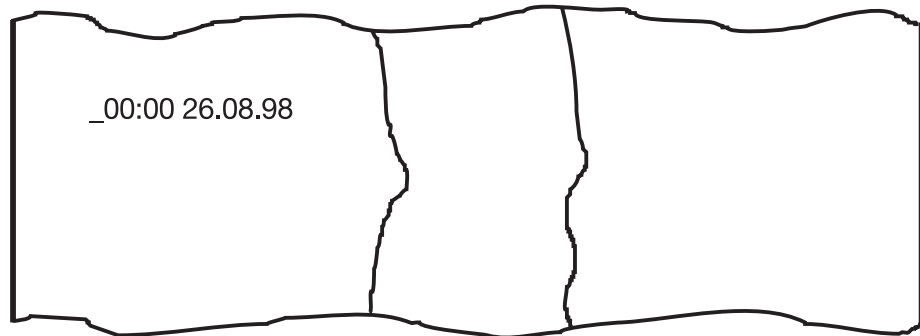

The spacings do not depend on the chart speed which has been set. The spacings listed above are only approximate, since the print is made at round values of time.

For every fourth print-out of the time, the current chart speed, the programmed instrument name, or the date are printed out alternately after the time.

The date is normally printed out when the date changes at 00:00 hrs.

To provide a precise time reference on the chart, a time reference mark (“_”) is placed before the time.

3 Operation and visualisation

3.2.6 Print out channel numbers

In order to associate measurements more clearly with a channel, the channel number can be printed next to the trace in the channel colour. The print-out is made cyclically, at a configurable spacing. (*C2-level* → *Print channel number*).

Selectable spacings:

- 2cm
- 4cm
- 6cm
- print switched-off

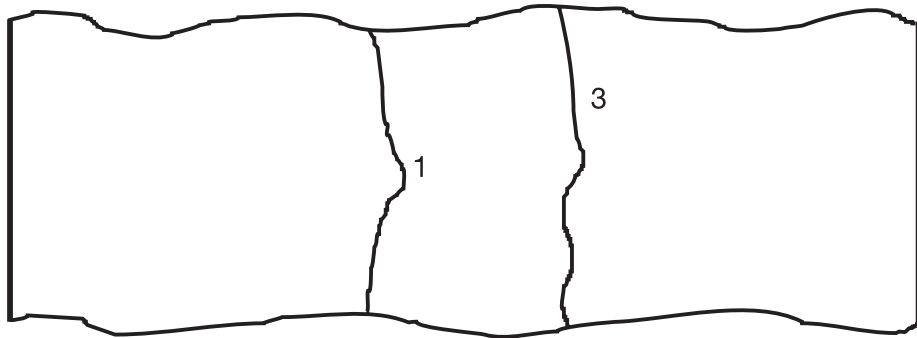

3.2.7 Recording start and stop

The start and end of a recording is registered by a configurable start and end text (*C2-level* → *Begin text*, *C2-level* → *End text*).

Text printing can be switched on or off separately for start and end. The print-out is made together with the time, and always in red.

Both texts will only be printed when the recording is enabled, i.e. the print of the end text is made "in arrears".

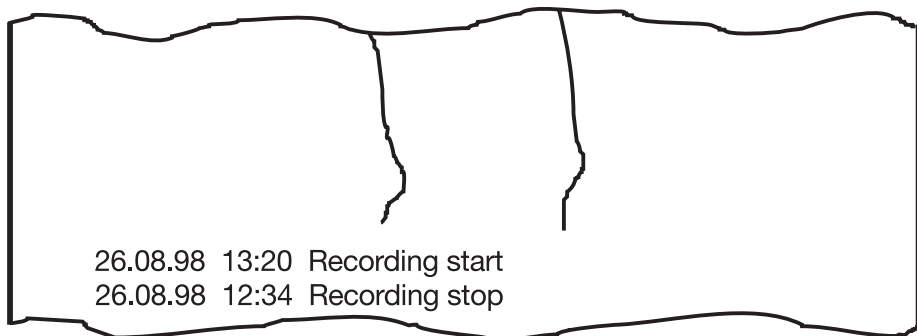

3 Operation and visualisation

3.2.8 Print test

The print test can only be enabled from the keys on the printing recorder. (*S-level* → *Print test*). It is used to test the function of the printing system and the print head.



The print test carries on until it is stopped by *Print test = Off*.



Any text prints which have been started will be aborted and **not** continued after the print test.



All requests for text printing which occur during the print test are stored and carried out after the print test.

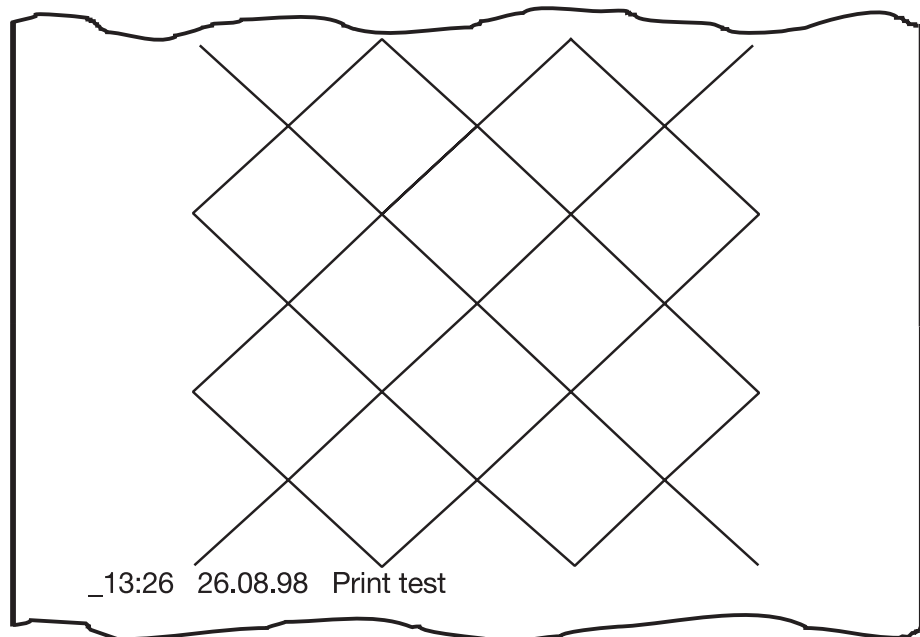

Six traces will always be printed, which means that all pens are tested. In this case, the parameter *C1-level* → *Plot status* has no effect.

3 Operation and visualisation

3.2.9 Service print

The service print can only be initiated from the keys on the printing recorder. (*S-level* → *Service print*).

The print-out consists of the current date and time, the software version, the number of power interruptions, the total operational time of the recorder in hours, and the minimum and maximum ambient temperature of the internal Pt100 cold junction.

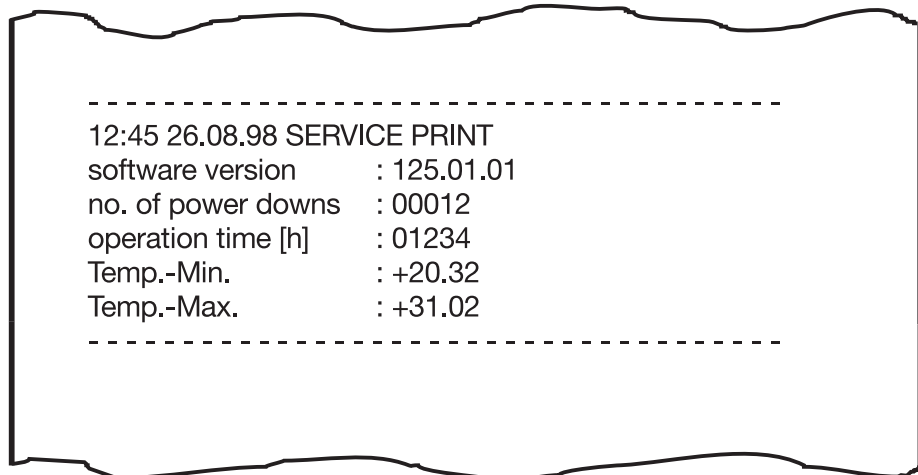

```
-----  
12:45 26.08.98 SERVICE PRINT  
software version      : 125.01.01  
no. of power downs   : 00012  
operation time [h]    : 01234  
Temp.-Min.           : +20.32  
Temp.-Max.           : +31.02  
-----
```



Any text print-outs which were started will be aborted and **not** continued after the service print.



All requests for text prints which occur during the service print will be stored and carried out after the service print.

4 Configuration table

4.1 Operating examples

Example 1 The date, time and weekday are to be programmed.

Key	Display	Description
	5 AMB. TEMP. +35.08°C	Recorder is in the basic status
▲ + ▼		Call up operating level
	S-LEVEL	(now in operating level)
▲ + ▼		Start code check
	CODE: 9200	Enter 9200, by using the ◀, ▶, ▲, ▼ keys
ENTER		Conclude entry of code number
	P-LEVEL	(now in parameter level)
▲		Call 1st. parameter of the parameter level
	LANGUAGE	
▲		Call next parameter
	DATE & TIME	
ENTER		Call parameter to be changed
	DATE: 26.08.98	Alter date, by using the ◀, ▶, ▲, ▼ keys
ENTER		Confirm date
	DAY: MONDAY	Alter weekday, by using the ▲, ▼ keys
ENTER		Confirm weekday
	TIME: 12:00	Alter time, by using the ◀, ▶, ▲, ▼ keys
ENTER		Confirm time
	DATE & TIME	Parameter entry is finished
↓E/E		Leave parameter level
	INITIALIZATION	As long as the display is flashing, the recorder is being initialised with the new data
	S-LEVEL	Recorder is in the operating level again.

4 Configuration table

Example 2

Starting from example 1, the instrument name is to be changed.

Key	Display	Description
	S-LEVEL	
▲ + ▼		Start code check
	CODE: 9200	Enter 9200, by using the ◀, ▶, ▲, ▼ keys
ENTER		Conclude entry of code number
	P-LEVEL	
▲ + ▼		Call up configuration level 1
	C1-LEVEL	
▲ + ▼		Call up configuration level 2
	C2-LEVEL	
▲		Call up 1st. parameter of this level
	UNIT NAME	(the instrument name)
ENTER		Call the parameter to be altered
	TEXT: LOGOPRINT junior	Enter instrument name, by using the ◀, ▶, ▲, ▼ and S keys
ENTER		Confirm instrument name
	UNIT NAME	Parameter entry is finished
↓E/E		Leave level
	C1-LEVEL	
↓E/E		Leave level
	P-LEVEL	
↓E/E		Leave level
	INITIALIZATION	As long as the display is flashing, the instrument is being initialised with the new data
	S-LEVEL	Recorder is at the operating level again
↓E/E		Leave operating level
	LOGOPRINT 26.08.98 09:45	Recorder is in basic status again

4 Configuration table

4.2 Table of the configuration parameters

All the parameters for the instrument are presented in the following table. The parameters are explained in the order in which they appear in the recorder.

The first column of the table shows the path through the levels to the particular parameter.



The “X” symbol stands for a number which is to be selected (e.g. channel number 1 – 6). This number is shown in the display of the printing recorder for all the sub-parameters.

To preserve a clear layout, the “X” is only shown for the first parameter in the table.

The settings or selections which are available for the parameter are shown in the second column.

The third column contains a description of the parameter or the selection options, if the selection or the function of the parameter are not obvious.

4.2.1 Operating level (S-level)

	Parameter	Value/selection	Description
Chart speed	S-level → Feed paper Feed paper:	0, 5, 10, 20, 60, 120, 240, 300, 360, 600, 720mm/h	Setting the chart speed
Print test	S-level → Print test Print test:	OFF, ON	Start print test The print test can be used to test the functioning of the printing system
Service print	S-level → Service print Service print:	NO, YES	Start service print The service print provides information on the software version, no. of power interruptions, total no. of operational hours of the recorder, as well as on the minimum and maximum ambient temperatures
Version number	S-level → Version number Version:	125.01.01	Displays the number of the software version

4 Configuration table

4.2.2 Parameter level (P-level)

	Parameter	Value/selection	Description
Language	P-level → Language Language:	ENGLISH FRENCH GERMAN	Select language The language setting affects all the non-programmable texts in the recorder which can be displayed or printed out
Date & time	P-level → Date & time Date: Day: Time:	DD:MM:YY MONDAY TUESDAY WEDNESDAY THURSDAY FRIDAY SATURDAY SUNDAY hh:mm	Programming the system clock The actual time is printed out for certain events and is used as a reference time for time-dependent events, such as summer time, for example
Summer time	P-level → Summer time Summer time: Start: Start: End: End:	OFF, ON Enter date: DD:MM:YY Enter time: hh:mm Enter date: DD:MM:YY Enter time: hh:mm	Entry for a period for which the system clock of the recorder will be adjusted to summer time. The period of summer time is only valid for the defined period of time. It must be programmed freshly each year. Start and end can only be entered if the status is set to ON.
Display brightness	P-level → Display Brightness: level	1 – 4	Display brightness 1 = dark 4 = very bright
Display time	P-level → Display time Display time:	ON, OFF	The time is shown on the recorder display in the basic status. By using this parameter, the time display can be inhibited (status = OFF).

4 Configuration table

4.2.3 Configuration level 1 (C1-level)

	Parameter	Value/selection	Description
Plot status	C1-level 1 → Plot status X Plot status Status:	1 – 6 ON, OFF	Setting for each recording channel: should the trace be printed on the chart or not
	Measurement input	C1-level → Input X Input Type:	1 – 6 VOLTAGE CURRENT SHUNT
C1-level → Input Type: Voltage Dimension (unit): Range start: Range end: Filter:		mV, V -9999 to +9999 $-10V \leq \text{range start} < 10V$ -9999 to +9999 $-10V < \text{range end} \leq 10V$ measurement span $\geq 5mV$ 0.0 – 50.0sec	Enter range start Enter range end Enter filter constant
C1-level → Input Type: Current / Shunt Range start: Range end: Filter:		-9999 to +9999 $-20mA \leq \text{range start} < 20mA$ -9999 to +9999 $-20mA < \text{range end} \leq 20mA$ meas. span $\geq 0.5mA$ 0.0 – 50.0sec	Enter range start Enter range end Enter filter constant
Scaling	C1-level → Scaling X Scaling: Dimension (unit): Zero: Full: Decimal point:	1 – 6 5 characters -9999 to +9999 -9999 to +9999 AUTO, x.xxx, xx.xx, xxx.x, xxxx.	Select reference channel Enter scaling start Enter scaling end Select decimal place

4 Configuration table

	Parameter	Value/selection	Description
Word and number (Channel designation)	C1-level → Word and number X Word and number	1 – 6	Enter channel designation for each channel
	Text:	16 characters	The designation is also printed on the chart during scaling, as well as being shown on the display together with the measurement. The complete character set is available

4.2.4 Configuration level 2 (C2-level)

	Parameter	Value/selection	Description
Instrument name	C2-level → Unit name Text:	16 characters	Enter instrument name
Print speed change	C2-level → Print speed change Status:	OFF, ON	Select the status for print-out of the change-over or alteration of chart speed
Print the “Power on” text	C2-level → Print “power on” text Status:	OFF, ON	Status for print-out of the “power on” text (if OFF: text entry not required)
	Text:	16 characters	Enter “power on” text
Print the “Power off” text	C2-level → Print “power off” text Status:	OFF, ON	Status for print-out of “power off” text (if OFF: text entry not required)
	Text:	16 characters	Enter “power off” text
Print the scaling	C2-level → Print scale Spacing:	OFF, 30, 60, 90cm	Determine the regular interval at which the scaling is to be printed on the chart
Print the time	C2-level → Print time Spacing:	OFF, 2, 4, 6cm	Determine the interval at which the time is to be printed on the chart
Print the channel numbers	C2-level → Print channel numbers Spacing:	OFF, 2, 4, 6cm	Determine the interval for printing the trace on the chart, labelled with the corresponding channel numbers

4 Configuration table

	Parameter	Value/selection	Description
Start text	C2-level → Begin text Status:	OFF, ON	Select the status for print-out of the start text (if OFF: text entry not required)
	Text:	16 characters	Enter start text
End text	C2-level → End text Status:	OFF, ON	Select the status for the print-out of the end text (if OFF: text entry not required)
	Text:	16 characters	Enter end text
Default setting (Presetting)	C2-level → Presetting Presetting:	NO, YES	Overwrite parameter/ configuration data with standard values

4 Configuration table

5 Identifying the instrument version

5.1 Instrument description

The printing recorder is equipped with 6 electrically isolated measurement inputs. The evaluation of the measurement traces of the printing recorder can be assisted by printed text.

The recorder can be programmed from the 8 keys on the instrument front. The configuration data are permanently stored in an EEPROM.

A 24-character LED dot-matrix display is available for checking and configuring the parameters and for displaying the present measurements on the instrument.

Voltages or currents (standard signals) are possible as input signals.

In the event of a power failure, the real-time clock is buffered by a lithium battery or a storage capacitor.

Block structure

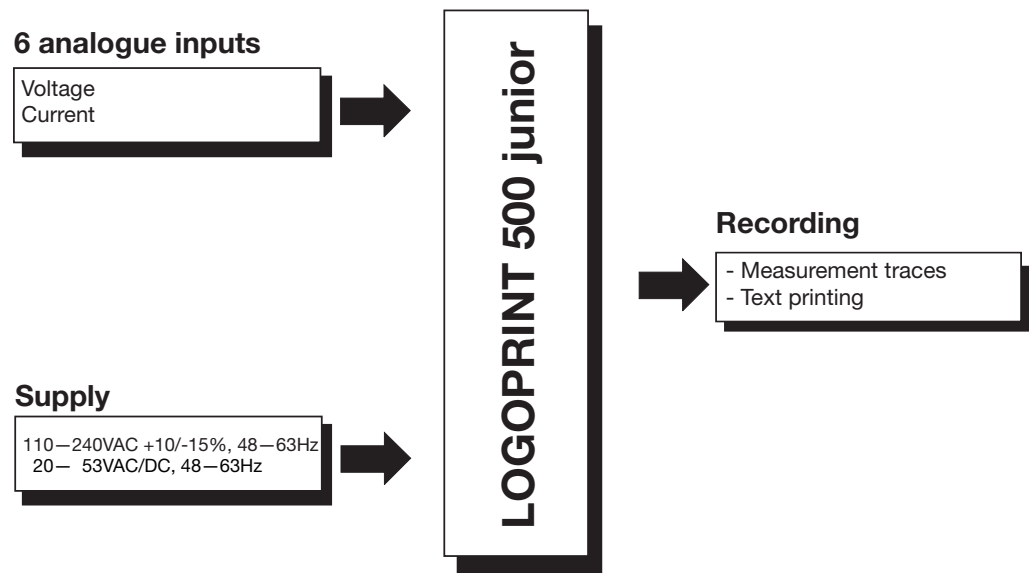

6.1 Location and climatic conditions

The installation site should be as free as possible from vibration. Stray electromagnetic fields, for instance those caused by motors, transformers etc., should be avoided where possible.

The ambient temperature at the location must not go outside the range 0 to +50°C, at a relative humidity between 20 and 70%, without condensation.

Corrosive air or fumes can affect the functioning and operational life of the printing recorder.

⇒ Section 7.1 “Installation notes”

6.2 Assembly in a control panel

Views

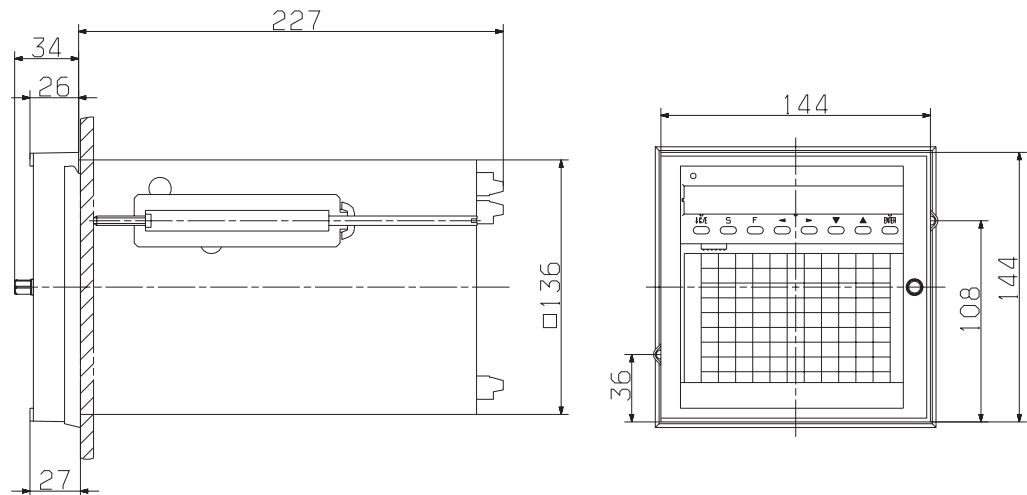

Dimension 26 increased to 27 when using the IP65 seal.

Panel cut-out

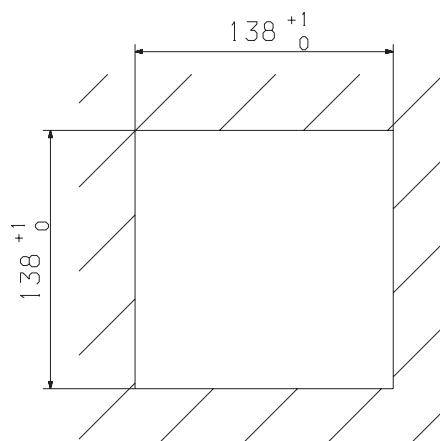

6 Installation

Mounting

- * Insert the printing recorder from the front into the panel cut-out
- * From the back of the panel, hook the two mounting brackets into the cut-outs in the sides of the housing. The flat faces of the brackets must lie against the housing.
- * Place the brackets against the rear of the panel, and tighten them evenly.

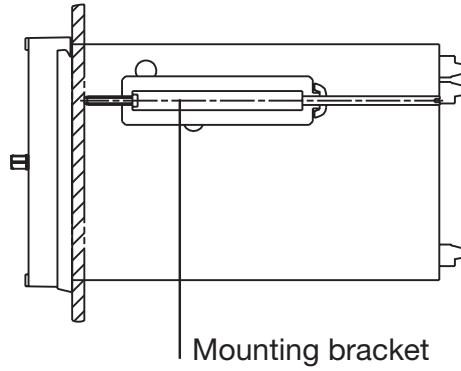

7.1 Installation notes

- The rules of VDE 0100 “Regulations on the Installation of Power Circuits with nominal voltages below 1000V” or the equivalent national standards must be observed for the selection of cables, installation and electrical connection of the instrument.
- Work inside the instrument may only be carried out by properly qualified personnel, and then only to the extent described. The same applies to electrical connections.
- Ensure that the instrument is isolated on both poles from the mains supply before carrying out work where live components may be touched.
- The electromagnetic compatibility (EMC) conforms to the standards and regulations cited in the Technical Data.
- It is recommended that input, output and supply cables are routed separately from one another, and not laid in parallel.
- All input and output lines that are not connected to the supply network must be laid out as shielded and twisted cables. The shielding must be grounded to the earth potential on the instrument side.
- Earth the instrument by connecting the PE terminal on the instrument to the protective earth. This line must have the same cross-section as the supply lines. Earth lines must be routed in star configuration to a common earthing point which is connected to the protective earth of the supply. Earthing leads must not be looped, i.e. led from one instrument to another.
- Do not connect any additional loads to the supply terminals of the instrument.
- The instrument is not suitable for installation in hazardous areas.
- Inductive loads in the neighbourhood of the instrument, such as contactors or solenoid valves, must have RC modules fitted for interference suppression.
- The supply to the instrument must be provided with additional fusing. Depending on the supply voltage, the values to be used are:

20 – 53V AC/DC, 48 – 63Hz	fuse 2A slow
110 – 240V AC +10/-15%, 48 – 63Hz	fuse 1A slow

7 Electrical connection

7.2 Technical data

Input for DC voltage, DC current

Basic range	Accuracy	Input resistance
-25 to +75mV	±100µV	R _E > 10 MΩ
0 – 100mV	±100µV	R _E > 10 MΩ
-100 to +100mV	±150µV	R _E > 10 MΩ
0 – 200mV	±150µV	R _E > 10 MΩ
-500 to +500mV	±1mV	R _E > 10 MΩ
0 – 1V	±1mV	R _E > 10 MΩ
-1 to +1V	±2mV	R _E > 10 MΩ
-5 to +5V	±10mV	R _E > 0.5 MΩ
0 – 10V	±10mV	R _E > 0.5 MΩ
-10 to +10V	±15mV	R _E > 0.5 MΩ
Shortest span	5mV	
Range start/end	freely programmable within the limits (up to 999mV in 0.01mV steps, above 1V in 1 mV steps)	
4 – 20mA	±20µA	burden voltage 2.6V max. burden voltage 2.6V max. burden voltage 2.6V max.
0 – 20mA	±20µA	
-20 to +20mA	±40µA	
Shortest span	0.5mA	
Range start/end	freely programmable within the limits in 0.1mA steps	
Measurement time	for 6 channels < 4sec	
Input filter	2nd order digital filter; filter constant adjustable from 0 – 50.0sec	

Transducer short-circuit/ break

	Short-circuit	Break
Voltage up to ± 1V	not recognised	recognised ¹
Voltage above ± 1V	not recognised	not recognised
Current	not recognised	not recognised

1. The print head is positioned to 0%, ">>>>>" appears in the LED dot-matrix display.

Printing system

Drive	stepper motor
Sensitivity	0.2% or better referred to 100mm writing width
Reproducibility	0.25% or better referred to 100mm writing width
Display and recording accuracy	Class 0.5 referred to range limits and basic ranges
Print head	print head with penlift function - sufficient for approx. 1 million dots (depending on the ambient temperature)
Print colours	violet, red, black, green, blue, brown
Over/underrun	electronically limited to 0 – 100mm writing width
Chart speed	programmable in the steps 0, 5, 10, 20, 60, 120, 240, 300, 360, 600, 720mm/h
Paper feed	by stepper motor and gearing
Chart cassette	cassette for roll chart and fanfold chart (with tear-off edge and paper-end switch)
Chart	roll or fanfold chart to DIN 16 320
overall width	120mm
writing width	100mm
sprocket roller spacing	110mm
visible diagram length	roll chart: 60mm; fanfold chart: 30 – 60mm
overall length	roll chart: 16m oder 32m; fanfold chart: 16m

7 Electrical connection

Electrical data

Supply	110 — 240V AC +10/-15%, 48 — 63Hz, or 20 — 53V AC/DC, 48 — 63Hz
Electrical safety	to EN 61 010, Part 1, March 1994 overvoltage category II, pollution degree 2
Test voltages (type test)	
- mains supply circuit to measurement circuit	with AC supply: 2.3kV 50Hz, 1 min, with AC/DC supply: 510V 50Hz, 1 min
- mains supply circuit to housing (protective earth)	with AC supply: 1.5kV 50Hz, 1 min, with AC/DC supply: 510V 50Hz, 1 min
- between measurement circuits	200V 50Hz, 1 min
- measurement circuits to housing	500V 50Hz, 1 min
- electrical isolation between the analogue inputs	up to 30V AC and 50V DC
Supply voltage error	less than 0.1 % of range span
Power consumption	35VA max.
Data buffering	more than 4 years by lithium battery in RAM or 2 days with storage capacitor at 15 — 25°C ambient temperature. Additional backup in EEPROM.
Electrical connection	at rear through plug-in screw terminals, max. conductor cross-section 2.5mm ² or 2x 1.5mm ² with ferrules.
EMC	EN 61 326
- interference emission	Class B
- immunity to interference	to industrial requirements

Housing

Housing type - housing door	housing for flush-panel mounting to DIN 43 700, galvanised steel die-cast zinc
Transport mechanism	in corrosion-resistant chrome-nickel steel
Chart cassette	in plastic (polycarbonate)
Bezel size	144mm x 144mm
Depth behind panel	212mm without screw terminals; 227mm with screw terminals plugged in
Panel cut-out	138 ^{+1.0} mm x 138 ^{+1.0} mm
Housing mounting	in control panel to DIN 43 834
Ambient temperature range	0 to +50°C
Ambient temperature error	0.2% per 10°C
Storage temperature range	-20 to +70°C (without print head), -20 to +55°C (with print head)
Climatic conditions	20 to 70% relative humidity, no condensation
Operating position	NL 90 ± 30, DIN 16 257 (vertical)
Protection	to EN 60 529 Category 2, front IP54 (IP65 with extra code 266), rear IP20
Weight	3.5kg max.

7 Electrical connection

<p>Current input (shunt) $\leq \pm 20\text{mA}$</p> <p>(when using transducers with changeable internal resistance; extra code "terminal with shunt" is required)</p>							1 ○	2 ○	3 ○	4 ○	5 ○
--	--	--	--	--	--	--	--------	--------	--------	--------	--------

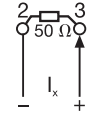

7.4 Isolation

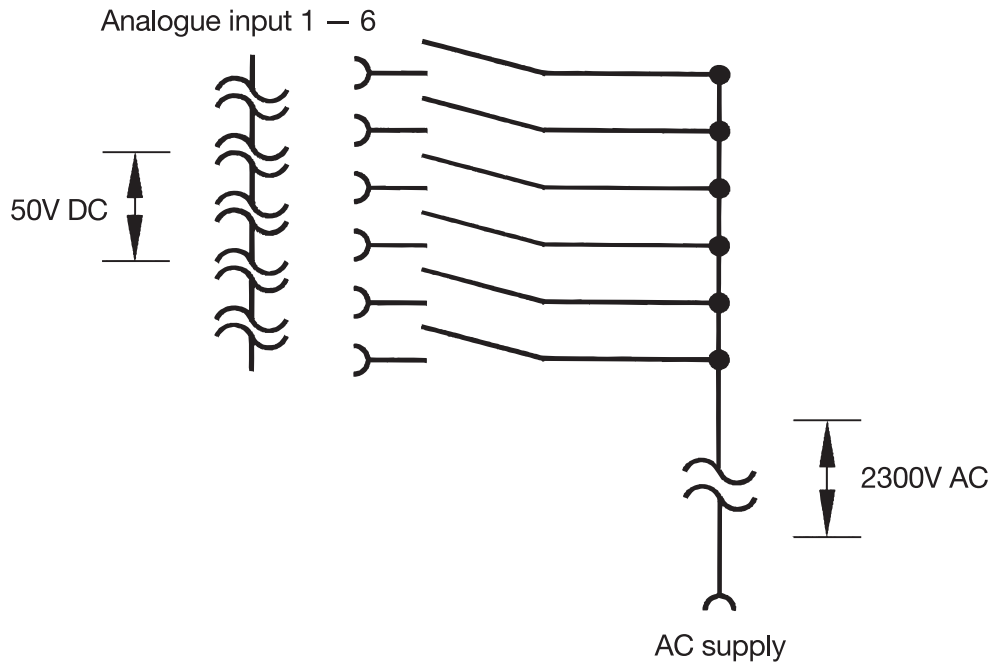

7 Electrical connection

8.1 Opening and closing the door

To open or close the door, press as shown in the illustration until a click can be heard.

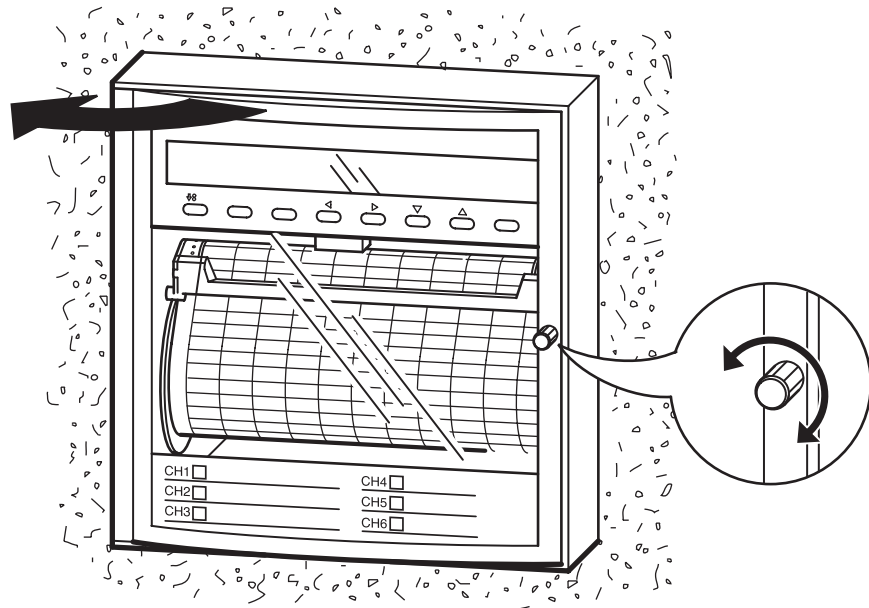

8.2 Marking the channel label

After the door has been opened, the channel label can be removed and marked, as required, with the channel-specific data, such as channel designation, scaling and unit.

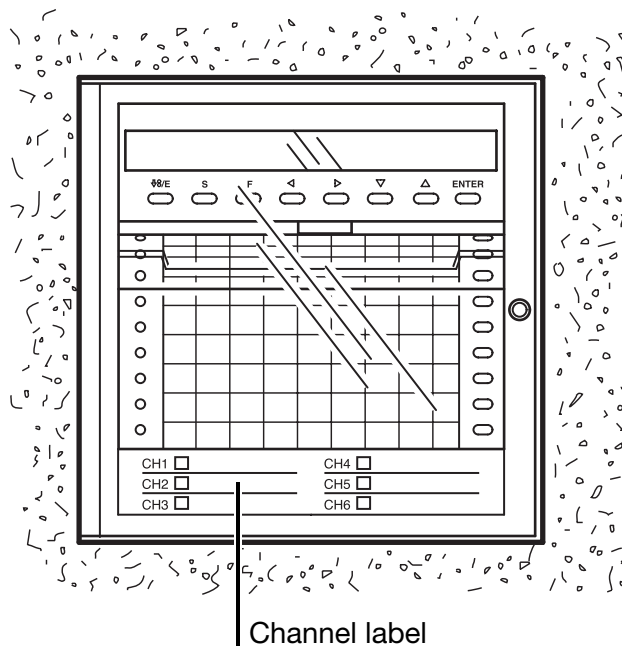

8 Starting up

8.3 Fitting the print head

- * Open the door
- * Stop recording (press **S** key)



In the stop state, the print head is always moved to the middle of the recording band.

- * Swing the display radially upwards
- * Push the print head into the holder, up to the stop
- * Swing the display downwards, until it snaps into place
- * Start recording again (press the **S** key)

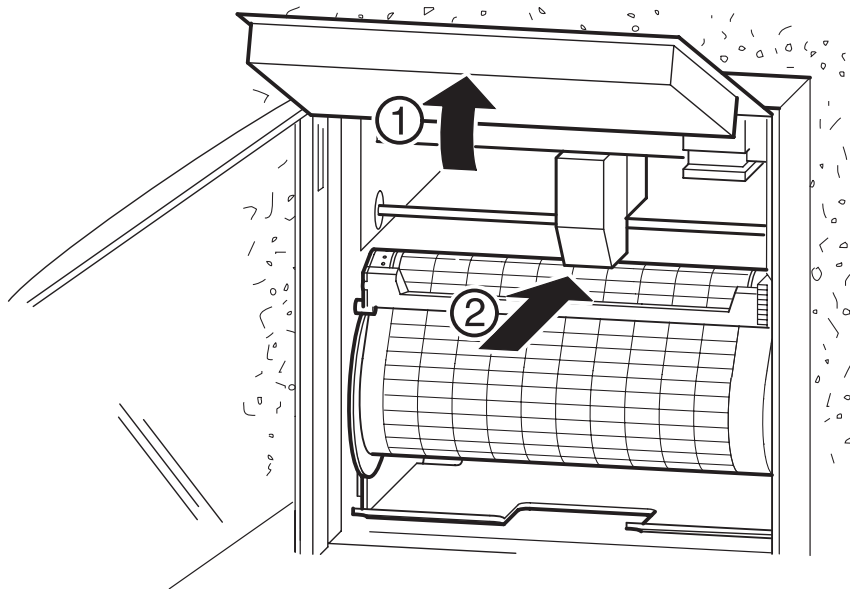

9.1 Consumables

Print head (2 items)

6 colours, Part No. 00355255

Roll chart (5 rolls)

no name, % graduation, linear

overall length: 16m

overall width: 120mm

Part No. 00331497

no name, % graduation, linear

overall length: 32m

overall width: 120mm

Part No. 00331499

no name, special graduation, linear

(marked as specified)

Fanfold chart (5 packs)

no name, % graduation, linear

overall length: 16m

overall width: 120mm

Part No. 00331490

no name, special graduation, linear

(marked as specified)

9 Consumables

9.2 Removing and replacing the chart cassette

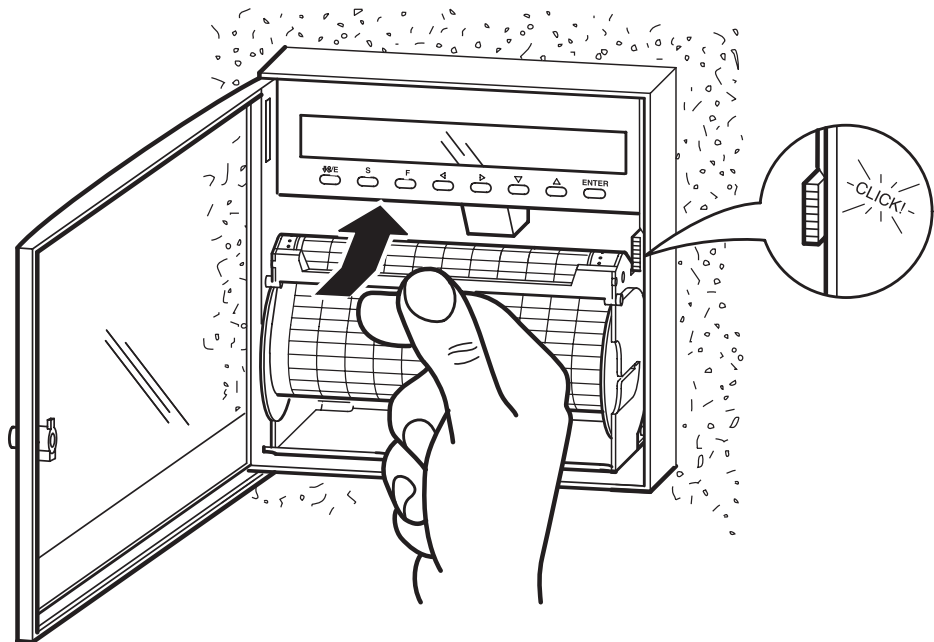
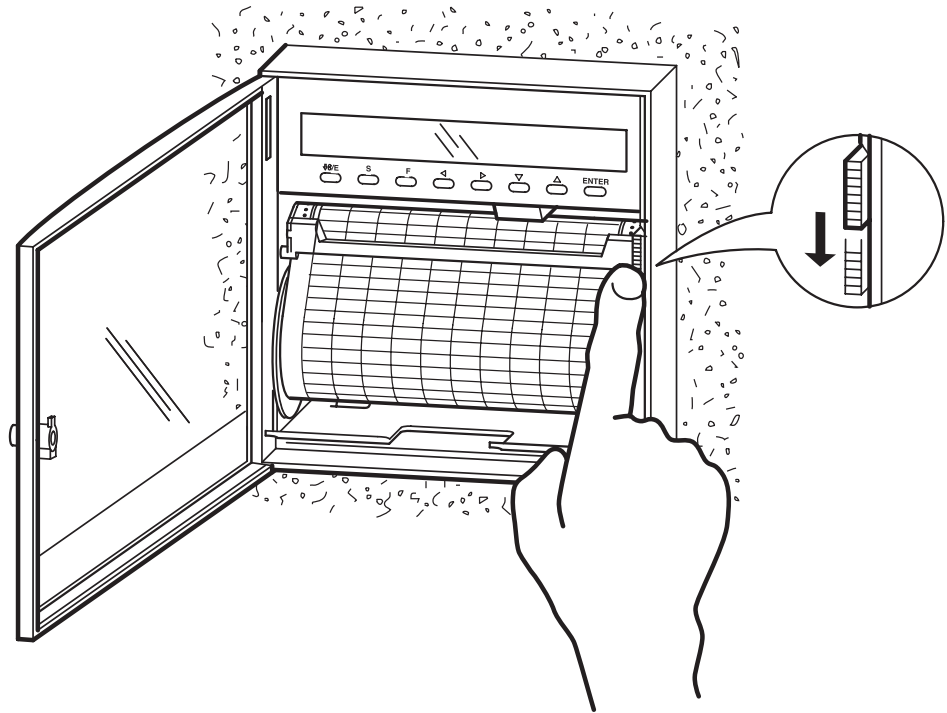

9.2.1 Changing the roll chart

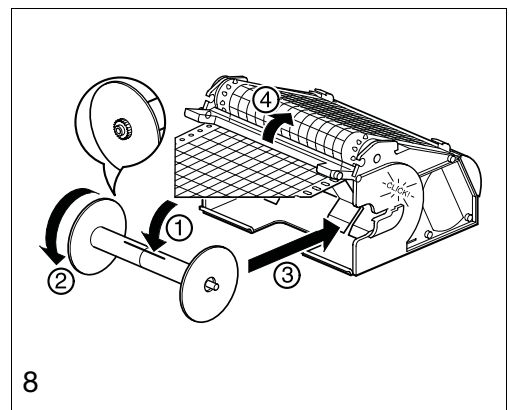
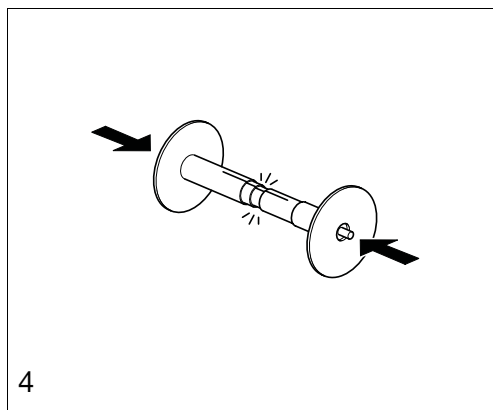
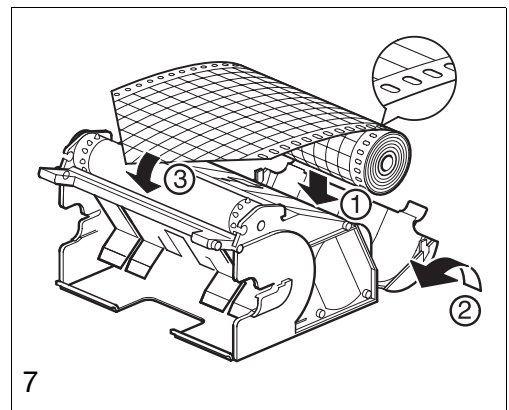
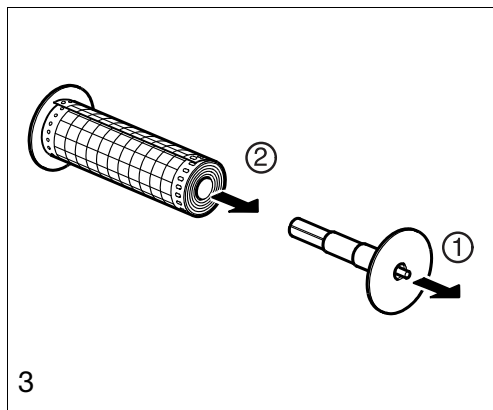
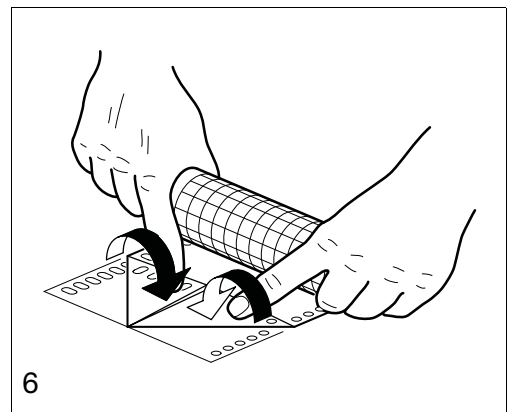
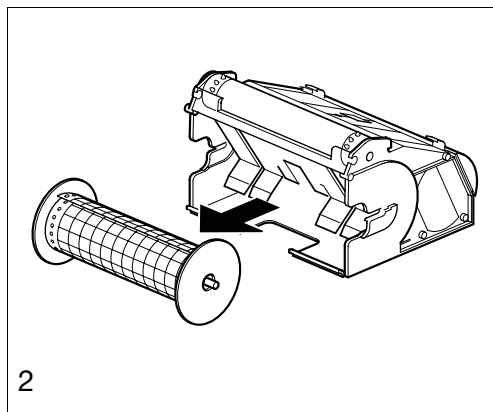
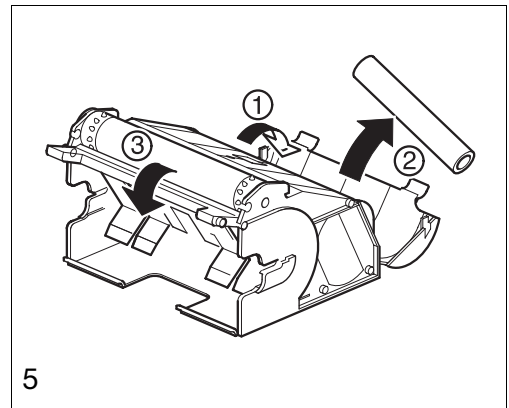
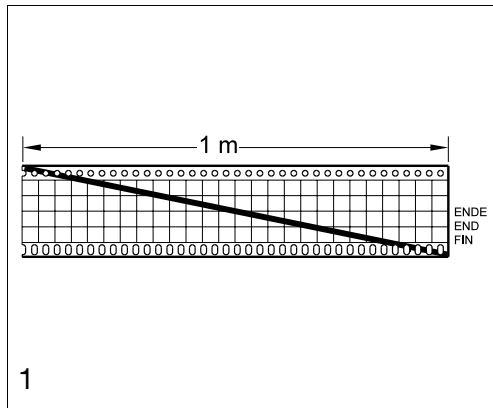

9 Consumables

9.2.2 Changing the fanfold chart

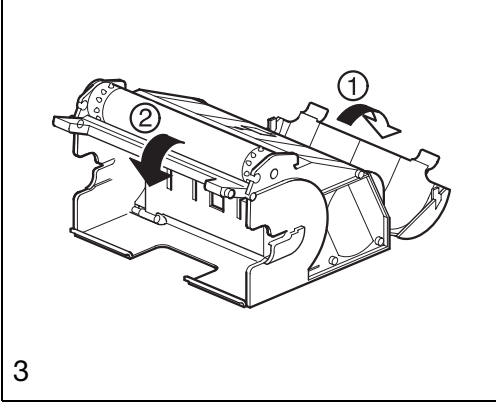
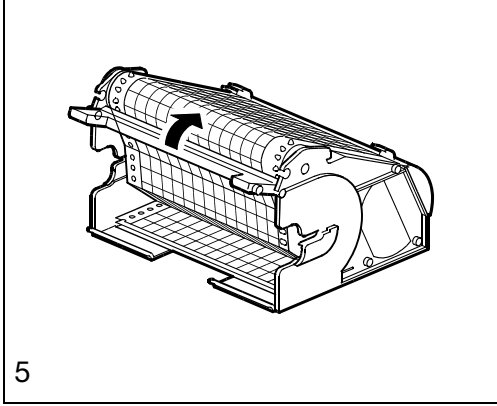
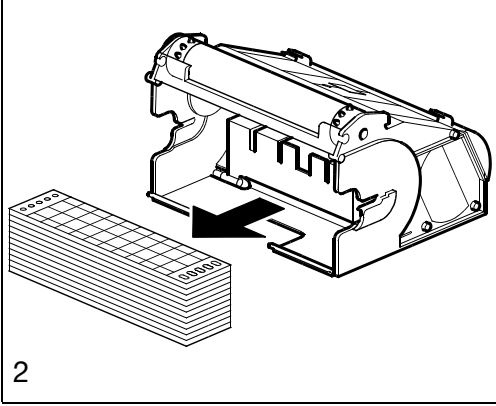
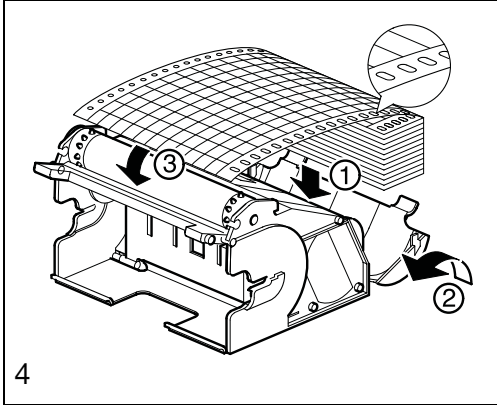
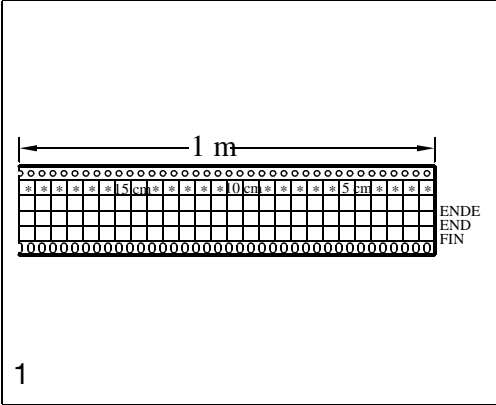

10.1 Converting the chart cassette

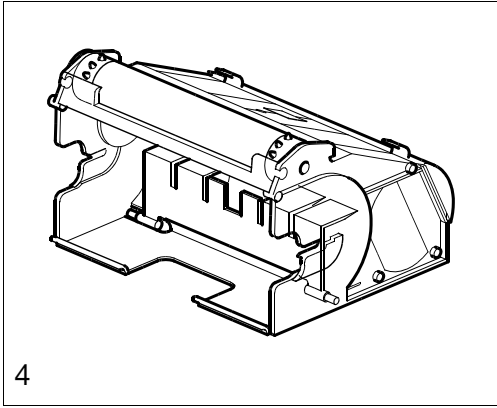
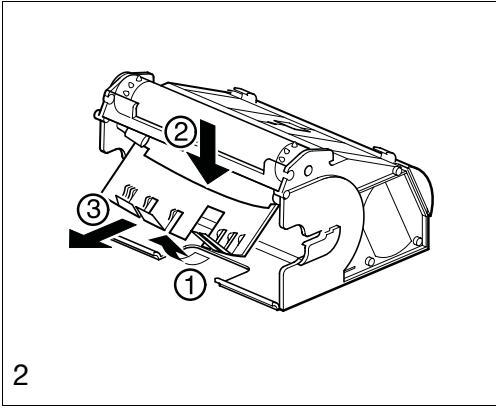
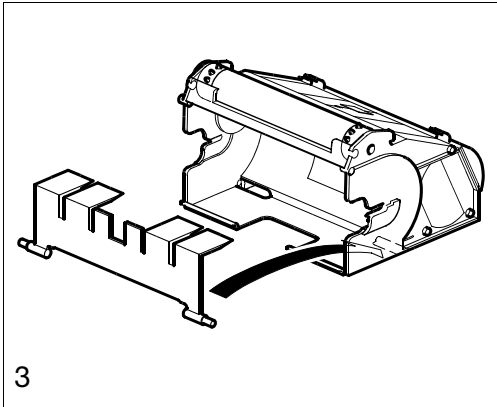
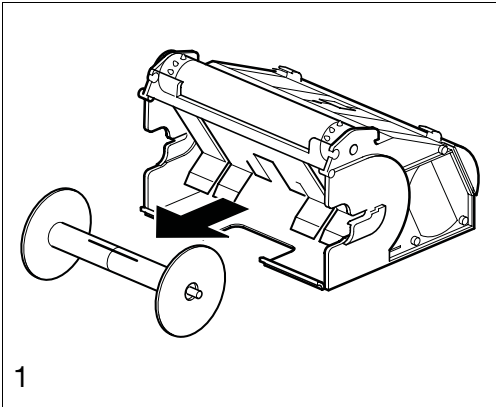

10 Accessories

11.1 What to do if ...

<p>Display or printing “>>>>>>”</p>	<ul style="list-style-type: none"> - The value is outside the measuring range (Out-of-range) - The transducer has been connected up incorrectly - The signal inputs are configured incorrectly - Probe break
<p>Instead of a value “****”, “±.***”, “±**.*”, “±***. ”, “±****.” is displayed or printed.</p>	<ul style="list-style-type: none"> - The value can no longer be represented: alter the scaling so that the value can always be displayed
<p>No recording</p>	<ul style="list-style-type: none"> - The  key was pressed - The chart cassette has not been fitted correctly ⇒ Section 9.2. “Removing and replacing the chart cassette” - The end of the chart has been reached ⇒ Section 9.2.1 “Changing the roll chart” ⇒ Section 9.2.2 “Changing the fanfold chart” - The chart speed has been programmed to 0 mm/h ⇒ Section 4.2 “Table of the configuration parameters” - The plot status is switched off (“OFF”) ⇒ Section 4.2 “Table of the configuration parameters”
<p>Print head doesn’t write</p>	<ul style="list-style-type: none"> - The print head has not been fitted correctly ⇒ Section 8.3 “Fitting the print head” - The ink of the print head has been used up
<p>No chart feed</p>	<ul style="list-style-type: none"> - The chart cassette has not been fitted correctly ⇒ Section 9.2 “Removing and replacing the chart cassette” - The chart speed has been programmed to 0mm/h ⇒ Section 4.2 “Table of the configuration parameters” - The paper perforation is not running correctly over the paper-feed sprocket - The tear-off edge is not properly engaged - The printing recorder is in the stop status

11 Fault finding

Measurements are not recorded	<ul style="list-style-type: none">- Check that the connection terminals are tightened properly- Check the supply- Check the input configuration (measurement range)- Check the transducer and their leads, measure them where appropriate- The plot status may be switched off
No programming possible	<ul style="list-style-type: none">- A wrong code number has been entered

12.1 Error messages

All error messages are displayed flashing in the LED dot-matrix display at regular intervals.

The other instrument functions are unaffected, as far as possible.

Display	Cause / Remedy
Status message	
NO PAPER!	<ul style="list-style-type: none"> - The chart cassette has been removed or the end of the chart has been reached, a fresh chart must be inserted. ⇒ Section 9.2 “Removing and replacing the chart cassette”
Error or fault in recorder	
LOW BATTERY!	<ul style="list-style-type: none"> - The battery for the real-time clock and for buffering the RAM is discharged - Please contact the nearest JUMO office or the main factory
ADJUST TIME!	<ul style="list-style-type: none"> - This error message is produced if the storage capacitor is discharged to too low a level during a supply failure (extra Code, ⇒ Section 5.2 “Ordering details”) - The power-off and operating time counters, minimum and maximum ambient temperatures, as well as the system clock are reset - The time must be set ⇒ Section 4.2 “Table of the configuration parameters”
A/D CONVERTER ERROR	<ul style="list-style-type: none"> - The A/D converter of the printing recorder is faulty - Please contact the nearest JUMO office or the main factory

12 Appendix

Display	Cause / Remedy
Error in parameter entry	
ERROR!	<ul style="list-style-type: none">- Chart speed is outside the range 0 – 720mm/h. The entry must be made again. Enter a value which is within the range of values.- Date is invalid. An invalid date has been entered. The entry must be made again.- Invalid time. An invalid time has been entered. The entry must be made again.- Incorrect value. The value which has been entered is outside the range of values. The entry must be made again, with a different value.

12.2 Hardware fault

If one of the following faults occurs, then the recording is aborted and the error message will be shown flashing on the display.

Display	Cause / Remedy
EEPROM-ERROR!	<ul style="list-style-type: none">- The EEPROM in the printing recorder is faulty, the configuration data can no longer be stored- Please contact the nearest JUMO office or the main factory.
NO ZERO!	<ul style="list-style-type: none">- The limit sensor (print head) has not been recognised- Please contact the nearest JUMO office or the main factory

If the instrument shows no reaction to any events and can not be operated any longer, please contact your nearest JUMO office or the main factory.

12.3 Status messages

The following status messages are indicated on the LED dot-matrix display:

Display	Description
INITIALIZATION	- The printing recorder is being initialised
STOP	- The recorder is in the stop status, because the  key has been pressed
PLEASE WAIT!	- The configuration data are being written to the EEPROM. The recorder will not react to any inputs during this time.

12 Appendix

12.4 Character set

032		079	O	0126	~	0212	Ô
033	!	080	P	0161	ı	0213	Õ
034	"	081	Q	0162	ç	0214	Ö
035	#	082	R	0163	£	0215	×
036	\$	083	S	0164	¤	0216	Ø
037	%	084	T	0165	¥	0217	Ù
038	&	085	U	0166	ı	0218	Ú
039	'	086	V	0167	§	0219	Û
040	(087	W	0168	¨	0220	Ü
041)	088	X	0170	ª	0221	Ý
042	*	089	Y	0171	«	0222	Þ
043	+	090	Z	0172	¬	0223	ß
044	,	091	[0173	-	0224	à
045	-	092	\	0175	-	0225	á
046	.	093]	0176	°	0226	â
047	/	094	^	0177	±	0227	ã
048	0	095	_	0178	²	0228	ä
049	1	096	`	0179	³	0229	å
050	2	097	a	0180	´	0230	æ
051	3	098	b	0181	µ	0231	ç
052	4	099	c	0182	¶	0232	è
053	5	0100	d	0183	·	0233	é
054	6	0101	e	0184	¸	0234	ê
055	7	0102	f	0185	ı	0235	ë
056	8	0103	g	0186	º	0236	ì
057	9	0104	h	0187	»	0237	í
058	:	0105	i	0191	¸	0238	î
059	;	0106	j	0192	À	0239	ï
060	<	0107	k	0193	Á	0240	ð
061	=	0108	l	0194	Â	0241	ñ
062	>	0109	m	0195	Ã	0242	ò
063	?	0110	n	0196	Ä	0243	ó
064	@	0111	o	0197	Å	0244	ô
065	A	0112	p	0198	Æ	0245	õ
066	B	0113	q	0199	Ç	0246	ö
067	C	0114	r	0200	È	0247	÷
068	D	0115	s	0201	É	0248	ø
069	E	0116	t	0202	Ê	0249	ù
070	F	0117	u	0203	Ë	0250	ú
071	G	0118	v	0204	Ì	0251	û
072	H	0119	w	0205	Í	0252	ü
073	I	0120	x	0206	Î	0253	ý
074	J	0121	y	0207	Ï	0254	þ
075	K	0122	z	0208	Ð	0255	ÿ
076	L	0123	{	0209	Ñ		
077	M	0124		0210	Ò		
078	N	0125	}	0211	Ó		

The characters which can be accessed with the **S** key (quick selection) are shown on a black background.

12.5 Summary of the parameters

Parameter	Description
Chart speed (Feed paper)	Chart speed in mm/h
Print test	Test the printing system
Service print	Print out information on the printing recorder
Version number	Display the version number
Code	Code number entry for level inhibit
Language	Language for print-outs and LED dot-matrix display
Date & time	System clock of the printing recorder
Summer time	Start and end of summer time
Display	Display brightness in four levels
Display time	Switch time on or off in display in basic status
Plot status	Plot status on/off for each channel
Measurement inputs	Select the analogue input signals, filters
Scaling	Scaling of the measurements for recording including the units and decimal place selection for alphanumeric display
Channel designation	Designation for each channel
Unit name	Designation of the recorder (instrument name)
Print speed change	Status for printing the speed change
Print "power on" text	Status and text for printing when the supply is switched on
Print "power off" text	Status and text for printing when the supply is switched off (this print-out only appears at the next switch-on)
Print scaling	Spacing (in cm) of the cyclic scaling print-out
Print time	Spacing (in cm) of the cyclic time print-out
Print channel number	Spacing (in cm) of the cyclic channel number print-out
Start (begin) text	Text which is printed at the start of recording
End text	Text which is printed at the end of recording
Presetting (default setting)	Reset parameters

A

Aborting programming 14
Accessories 55
Analogue inputs 44, 46, 63
Assembly in a control panel 41

B

Basic status 16
Bestellangaben 40

C

Channel number 27, 36
Character set 62
Chart cassette 52, 55
Chart speed 24, 26, 33, 36
Colour assignment 30
Configuration level 18–19
Configuration level 1 35
Configuration level 2 36
Confirming parameters 14
Connection diagram 46
Consumables 51
Cyclic display 16
Cyclic scaling print 25

D

Date 34
Default setting (presetting) 37
Dimension (unit) 35
Display and controls 11
Display brightness 34
Display time 16, 34
Door 49

E

Electrostatic discharges (ESD) 7
End text 27, 37
Error messages 59
Error messages during programming 14

F

Fanfold paper 54
Fault finding 57

13 Index

Fault signal LED 11
Filter 35, 63

G

Graphics print-out 21

I

Installation 41
Installation notes 43
Instrument description 39, 43
Instrument name 26
Isolation 47

K

Key combinations 13
Key functions 13
Keys 10

L

Language 34
LED for fault signals 11
Location 49

M

Measurement input 35
Menu items 10

N

Note signs 9

O

Operating examples 31–32
Operating level 17, 33
Ordering details 40

P

Parameter level 18, 34
Plot status 35
Power off 36
Power on 36

Presentation 10
Print head 50
Print test 28, 33
Printing priorities 23
Priorities, list of 23

R

Returning 7
Roll chart 53

S

Scaling 24, 35–36
Selection 14
Service print 29, 33
Speed change 36
Start text (begin text) 27, 37
Start-up 7
Static display 16
Summer time 34

T

Technical data 44–45
Text printing 23–30
Time 26, 34, 36

V

Value/text entry 15
Version number 33

W

Warning signs 9
Warranty 7
Word and number 36



JUMO GmbH & Co. KG

Street address:
Moltkestraße 13 - 31
36039 Fulda, Germany
Delivery address:
Mackenrodtstraße 14
36039 Fulda, Germany
Postal address:
36035 Fulda, Germany
Phone: +49 661 6003-0
Fax: +49 661 6003-607
e-mail: mail@jumo.net
Internet: www.jumo.net

JUMO Instrument Co. Ltd.

JUMO House
Temple Bank, Riverway
Harlow, Essex CM20 2TT, UK
Phone: +44 1279 635533
Fax: +44 1279 635262
e-mail: sales@jumo.co.uk
Internet: www.jumo.co.uk

JUMO PROCESS CONTROL INC.

885 Fox Chase, Suite 103
Coatesville, PA 19320, USA
Phone: 610-380-8002
1-800-554-JUMO
Fax: 610-380-8009
e-mail: info@JumoUSA.com
Internet: www.JumoUSA.com