

LOGOLINE 500

Pen recorder with text printing

B 70.6001.0 Operating Manual

2009-09-28/00331463

Levels and key functions

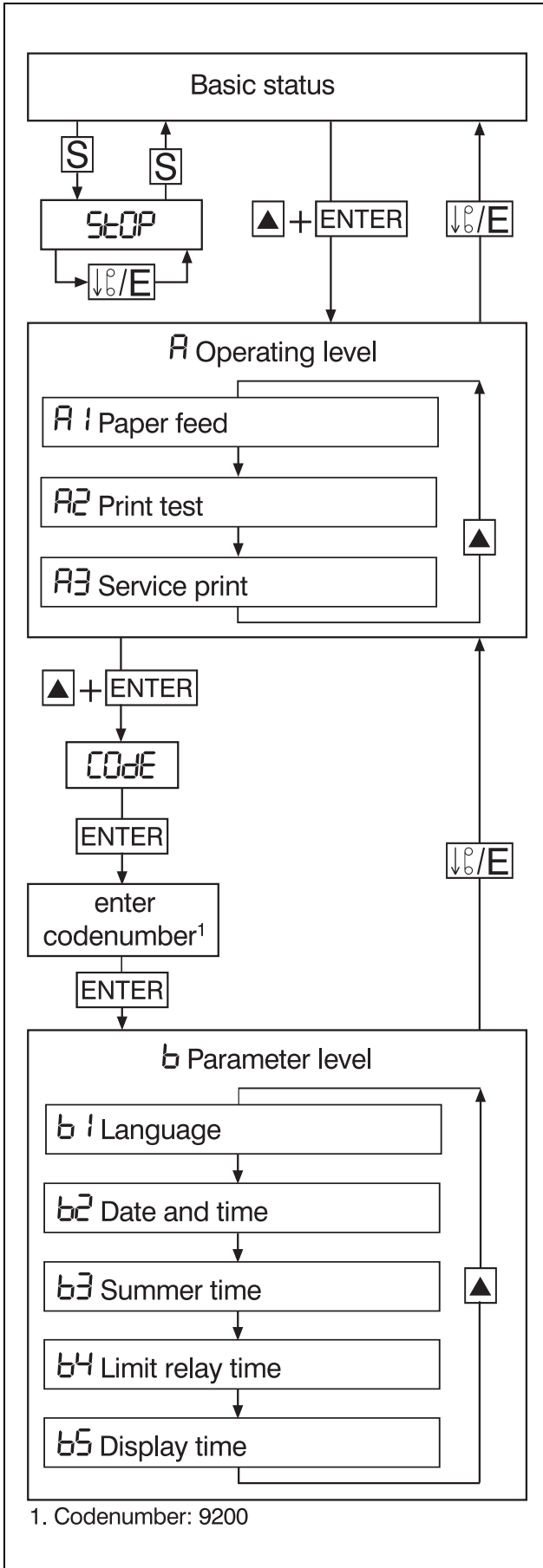

Key functions

↓p/E	<ul style="list-style-type: none"> - Chart fast forward when recording is stopped - Aborting parameter input (Exit) - Level change backwards
S	<ul style="list-style-type: none"> - Start/Stop recording - Decimal place selection during value input
F	<ul style="list-style-type: none"> - Function key for special function (hold down at least 4 sec) <p>factory setting: scale printout</p>
◀	<ul style="list-style-type: none"> - Move cursor left (select digit)
▲	<ul style="list-style-type: none"> - Parameter selection - Channel selection - Value selection from value table - Increment current digit
ENTER	<ul style="list-style-type: none"> - Initiate parameter input - Enter input - Acknowledge error message
▲ + ENTER	<ul style="list-style-type: none"> - Level change forwards

Contents

1 About this Manual

1.1	Introduction	5
1.2	Arrangement of the documentation	6
1.3	Typographical conventions	7
1.3.1	Warnings	7
1.3.2	Notes	7
1.3.3	Presentation	8

2 Identifying the instrument version

2.1	Instrument description	9
2.2	Type designation	10
2.3	Accessories	12

3 Installation

3.1	Location and climatic conditions	13
3.2	Fitting in position	14

4 Electrical connection

4.1	Notes on installation	15
4.2	Connection diagram	16

5 Starting up

5.1	Display and controls	18
5.2	Opening and closing the door	18
5.3	Marking the channel label	18
5.4	Fitting the fibre pens	19

6 Preparation

6.1	Operating modes and status	20
6.2	Operating principle	22

7 Text printing

7.1	Printing priorities	27
7.2	Printing modes	30
7.3	Clock time	32
7.4	Scaling	33
7.5	Changing the chart speed	35
7.6	Recording start and end	37
7.7	External text, binary-linked text, relay texts	38
7.8	Incrementing the event counter	40
7.9	Statistical report	41
7.10	Print test	42
7.11	Service print	43

Contents

8 Programming

8.1	Basic status	44
8.2	Operating level	45
8.3	Chart speed	46
8.4	Print test	47
8.5	Service print	48
8.6	Level inhibit and code request	49
8.7	Parameter level	50
8.8	Language	51
8.9	Date and time	52
8.10	Summer time	53
8.11	Relay limits	55
8.12	Display of time	57

9 Consumables

9.1	Summary of consumables	58
9.2	Removing and replacing the chart cassette	59
9.2.1	Changing the roll chart	61
9.2.2	Changing the fanfold chart	62

10 Extra Codes and accessories

10.1	Converting the chart cassette	63
10.2	Extra Code zf	64
10.3	External relay module ER8	65
10.4	Setup program	68
10.5	Maths and Logics module	70
10.6	Interface (RS422 / RS485)	71

11 Fault finding

11.1	What to do if...	72
------	------------------------	----

12 Appendix

12.1	Technical data	74
12.2	Error messages	78
12.3	Hardware fault	80
12.4	Status messages	81
12.5	Character set	82
12.6	Summary of the parameters	83

Index

1 About this Manual

1.1 Introduction



Please read this Operating Manual before commissioning the instrument. Keep the manual in a place that is accessible to all users at all times.

Please assist us to improve this manual, where necessary.

Your suggestions will be welcome.

Phone +49 6616003-0

Fax +49 6616003-607



All necessary settings are described in this manual. If any difficulties should still arise during start-up, you are asked not to carry out any manipulations on the unit. You could endanger your rights under the instrument warranty!

Please contact the nearest subsidiary or the head office in such a case.



When returning modules, assemblies or components, the regulations of EN 61340-5-1 and EN 61340-5-2 "Protection of electronic devices from electrostatic phenomena" must be observed. Use only the appropriate **ESD** packaging material for transport.

Please note that we cannot accept any liability for damage caused by ESD (electrostatic discharge).

1 About this Manual

1.2 Arrangement of the documentation

The documentation for this instrument consists of the following parts:

Operating Manual B 70.6001.0

This Operating Manual is always supplied with the instrument. It is addressed to the OEM (original equipment manufacturer) and to the user with appropriate technical know-how.

In addition to installation and electrical connection it contains all the information on instrument start-up, operation and parameter setting.

Interface Description B 70.6001.2

This Operating Manual is supplied with the instrument if the Extra Code “RS422” or “RS485” has been ordered. It provides information about communication with higher-level (supervisory) systems.

Online Help

The online help is part of the setup program. It is a Windows¹ online help.

 Section 10.4

¹ Microsoft and Windows are registered trademarks of the Microsoft Corporation

1 About this Manual

1.3 Typographical conventions

1.3.1 Warnings

The signs for **Danger** and **Warning** are used in this Manual under the following conditions:



Danger This symbol is used when there may be **danger to personnel** if the instruction is disregarded or not followed accurately.



Warning This symbol is used when there may be **damage to equipment or data** if the instruction is disregarded or not followed accurately.



Warning This symbol is used where precautions have to be observed during the handling of components which may be damaged by electrostatic discharge.

1.3.2 Notes



Note This symbol is used if your **special attention** is drawn to a remark.



Reference This symbol refers to additional information in other handbooks or sections.

abc¹

Footnote Footnotes are notes which refer to certain points in the text.

Footnotes consist of 2 parts:

Markings in the text and the footnote text.

The markings in the text are arranged as continuous raised numbers.

1 About this Manual

* **Action** This symbol indicates that an action is being described.

The individual steps are indicated by this symbol, e.g.:

* press key 

* enter with 

1.3.3 Presentation

 + 

Keys Keys are shown as boxes. Both symbols and text are possible. Where a key has multiple functions, the text shown is the one corresponding to the actual function discussed.

Program manager

Screen texts Texts displayed in the setup program are identified by italics.

*Edit →
instrument data...*

Menu items Menu items of the setup program which are referred to in this Manual are shown in italics. Menu name, menu item and submenu item are each separated by the symbol "→".

2 Identifying the instrument version

2.1 Instrument description

The pen recorder provides 1, 2 or 3 channels for recording; the channels are isolated from each other by optocouplers. Channel 1 can be used to write text in addition to the signal trace. All three channels are zeroed using Hall sensors. The measurements can be indicated by pointers against scales.

A 4-digit 7-segment display is available for programming. Operation is by six keys on the instrument front and via a setup program using a PC. The configuration data are stored permanently in EEPROM.

Input signals include resistance thermometers, resistance transmitters, thermocouples, standard current and voltage signals. The necessary linearisation is performed automatically. Eight logic inputs are available for operating functions. An external relay module ER8 for rail mounting supplements the pen recorder by eight switching outputs. A 2-wire transmitter can be operated from an isolated supply. The watchdog monitors the recorder operation and triggers a restart in case of a fault. On a power failure the real-time clock is supplied by a lithium battery or a storage capacitor.

A summary of all recorder parameters is given in the Appendix (⇒ Section 12.6).

2 Identifying the instrument version

2.2 Type designation

The label is affixed to the housing. The instrument version can be identified from the type designation.

The extra codes are listed in sequence and separated by a comma.

The voltage of the supply must agree with the voltage shown on the label.

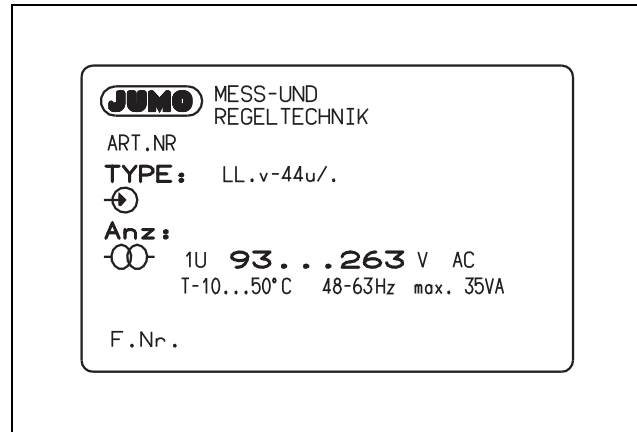

LL.v-44u/... Pen recorder
with scales

- 1 1 channel
with text writing
- 2 2 channels
(channel 1 with text writing)
- 3 3 channels
(channel 1 with text writing)
- v amplifier
- 44 bezel
144 mm x 144 mm
- u convertible chart cassette

Interface

RS422 serial interface
for communication with
higher-level systems

or

RS485 serial interface
for communication with
higher-level systems

2 Identifying the instrument version

Extra Codes

sk	special scales, e.g. in m ³ /h, bar etc. (to calibration curve if non-linear)
zf	extra functions: <ul style="list-style-type: none">- 8 logic inputs- 1 isolated supply for 2-wire transmitter- 1 serial interface for external relay module ER8
c	storage capacitor (ex-factory: lithium battery)
fp	cassette for fanfold chart 16m long
r32	roll chart 32m long
ab	housing for wall mounting. ¹ The panel-mounting housing is fitted in a carrier and can be swung out through 90°.
tm	housing with carrying handle, rubber feet and terminal cover, also 3m mains supply cable with grounding plug ¹
TG-35	portable recording station ²
ts	door with lock (IP54)
IP65	IP65 seal, wide mounting brackets

¹ UL approval is not available.

² This extra code is available in combination
with supply voltage 93—263V AC, not with
low supply voltage. UL approval is not avail-
able. The protection type in the carrying case
corresponds to IP20, outside IP20D.

2 Identifying the instrument version

Ordering example

(1) (2) (3) (4) (5) (6)

LL 3 v-44u/ ts, fp, tm

(1), (3) pen recorder

(2) 3 channels

(3) bezel 144 mm x 144 mm

(4) door with lock (IP54)

(5) fanfold chart cassette

(6) housing with carrying handle

Standard accessories

- 1 Operating Manual
- 2 Mounting brackets
- cable-tie with foot (can be released)
for tension relief of the sensor leads
connected
- 1 Fibre pen, disposable, for each channel
- 2 Chart rolls 16m long
or
1 Chart roll 32m long
(with Code r32)
or
1 Fanfold chart pack 16m long
(with Code fp)

2.3 Accessories

PC interface with TTL/RS232 converter

Setup program on 3.5" diskette

 Section 10.4

External relay module ER8

 Section 10.3

3 Installation

3.1 Location and climatic conditions

The instrument location should as far as possible be free from shock and vibration. Stray electromagnetic fields, e.g. from motors, transformers etc., should be avoided where possible.

The ambient temperature at the location may be between -10 and $+50^{\circ}\text{C}$ at a relative humidity not exceeding 75%, without condensation.

Corrosive air or fumes may interfere with the function and life of the recorder.



Section 4.1



Section 12.1

3 Installation

3.2 Fitting in position

Side view

(dimension 26 increased to 27 when using the IP65 seal)

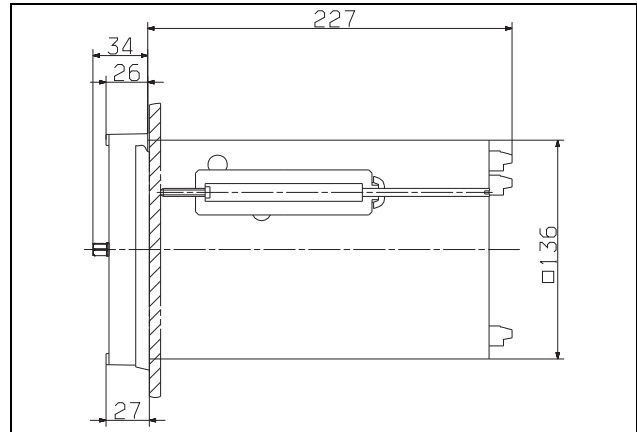

Front view

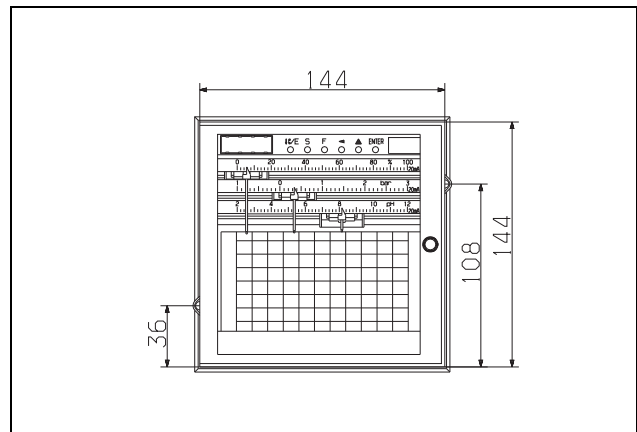

Panel cut-out

mm	inch
22.5	0.89
30	1.2
36	1.42
60	2.4
100	3.94
108	4.25
110	4.33
120	4.72
136	5.35
138 ⁺¹	5.43 ^{+0.04}
144	5.67
227	8.94
16 m	53 ft
32 m	107 ft
1.5 mm ²	0.0025 in ²
2.5 mm ²	0.004 in ²

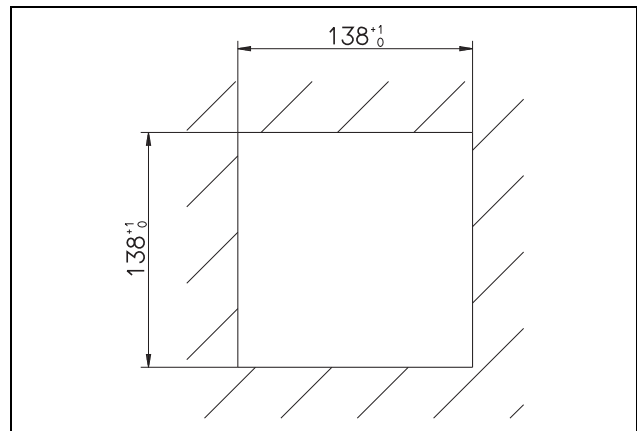

- * Insert the recorder from the front into the panel cut-out.
- * From the back of the panel hook the mounting brackets (1) into the cut-outs in the sides of the housing. The flat bracket faces must lie against the housing.
- * Place the brackets against the rear of the panel and tighten them evenly.

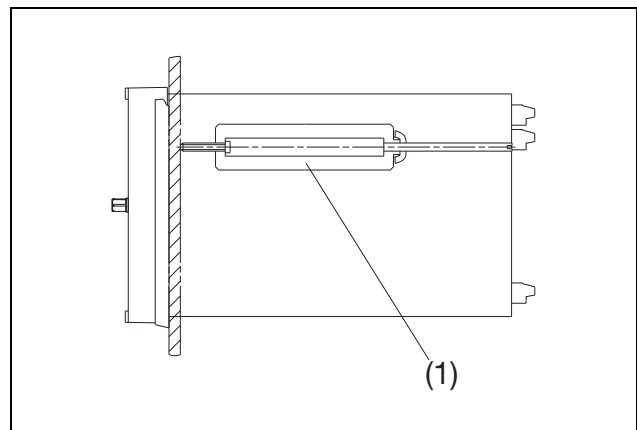

4 Electrical connection

4.1 Notes on installation

- ❑ The choice of cable, the installation and the electrical connection of the instrument must conform to the requirements of VDE 0100 “Regulations on the Installation of Power Circuits with nominal voltages below 1000 V” or the appropriate local regulations.
- ❑ Earth the instrument at terminal PE to the earth conductor. This line should have at least the same cross-section as the supply lines. Earth lines should be run in a star layout to a common earth point which is connected to the earth conductor of the supply. Do not loop the earth connections, i.e. do not run them from one instrument to another.
- ❑ Work inside the instrument must only be carried out to the extent described, and like the electrical connection only by properly qualified personnel.
- ❑ Do not connect any additional loads to the supply terminals of the instrument.
- ❑ If contact with live parts is possible when working on the instrument it has to be isolated on both poles from the supply.
- ❑ The instrument is not suitable for installation in hazardous areas.
- ❑ Electromagnetic compatibility (EMC) conforms to the standards and regulations listed under Technical Data.
⇒ Section 12.1
- ❑ Inductive loads in the neighbourhood of the instrument, such as contactors or solenoid valves, should be fitted with RC modules for interference suppression.
- ❑ Run input, output and supply lines separately and not parallel to each other.
- ❑ The instrument must be provided with external fusing and disconnection. Depending on the supply voltage, the following fuse values apply for the external fusing:
20 — 53V AC/DC, 48 — 63Hz
fuse 5A slow-blow
93 — 263V AC, 48 — 63Hz
fuse 5A slow-blow
- ❑ All input and output lines that are not connected to the supply network must be laid out as shielded and twisted cables. The shielding must be grounded to the earth potential on the instrument side.

4 Electrical connection

4.2 Connection diagram



The electrical connection must only be carried out by properly qualified personnel.

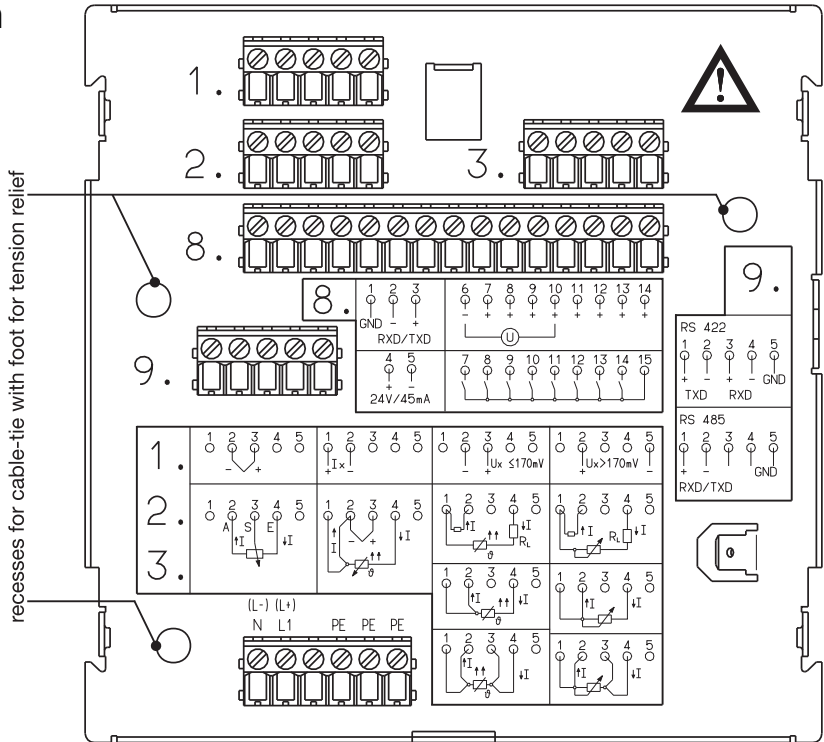

Rear view with screw clamp connectors

Terminals			
Supply as on label	N neutral L1 line PE potential earth	N (L-) L1 (L+) PE	(L-) (L+) N L1 PE PE PE 1 2 3 4 5 6
Analogue inputs	Input 1	Input 2	Input 3
Voltage input up to 170 mV	Field	Field	Field
Voltage input above 170 mV			1 2 3 4 5 - + Ux $\le 170\text{mV}$
Current input			1 2 3 4 5 + Ix -
Thermocouple			1 2 3 4 5 - +
Thermocouple with external Pt 100 cold junction			1 2 3 4 5 + I - + I

4 Electrical connection

Analogue inputs	Input 1	Input 2	Input 3	
Resistance thermometer/potentiometer in 2-wire circuit	Field	Field	Field	
Resistance thermometer/potentiometer in 3-wire circuit	1.	2.	3.	
Resistance thermometer/potentiometer in 4-wire circuit				
Resistance transmitter with 3-wire connection				<p>A = start S = slider E = end</p>
				<p>* $R_{comp} = R_{line}$</p>

External relay module ER8	Communication with external relay module ER8	Field	
Supply for external 2-wire transmitter	24 V ±5% 45 mA	8.	
Logic operating inputs	Contact operation: LOW = $R_{OFF} = 100 \text{ k}\Omega \text{ min.}$ HIGH = $R_{ON} = 50 \Omega \text{ max.}$		<p>Terminal 7 = logic input 1 ... Terminal 14 = logic input 8</p>
Minimum pulse duration: HIGH 500 msec LOW 500 msec	Voltage operation LOW = 0 — 5 V DC (not activated) HIGH = 20 — 35 V DC (activated)		<p>Terminal 7 = logic input 1 ... Terminal 14 = logic input 8</p>
Serial interface RS422 or RS485	Communication with higher-level systems	9.	<p>RS 422 RS 485</p>

5 Starting up

5.1 Display and controls

- (1) 4-digit 7-segment LED display
- (2) fibre pen, channel 3, green
- (3) fibre pen, channel 2, red
- (4) fibre pen, channel 1, blue
- (5) chart
- (6) setup interface (behind cover)
- (7) keys for operation and programming
- (8) door
- (9) housing to IEC 61554 for flush panel mounting, galvanised steel
- (10) channel marker label

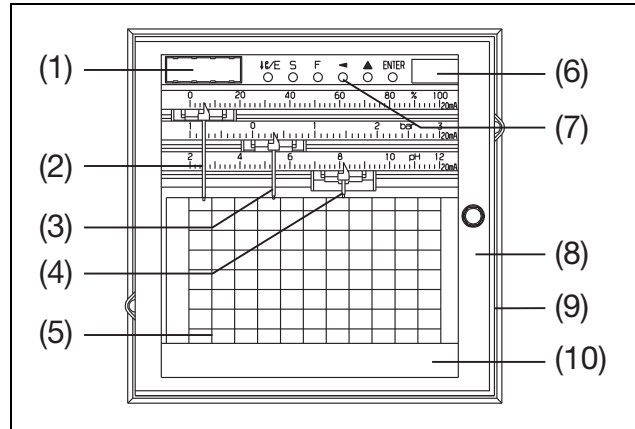

5.2 Opening and closing the door

Turn the knob to open or close the door.

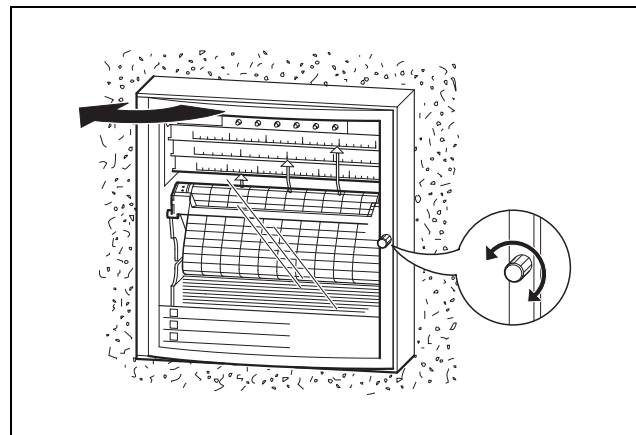

5.3 Marking the channel label

Please mark the channel label (1) with the measurement channel designation and the corresponding range (plot area and offset where appropriate).

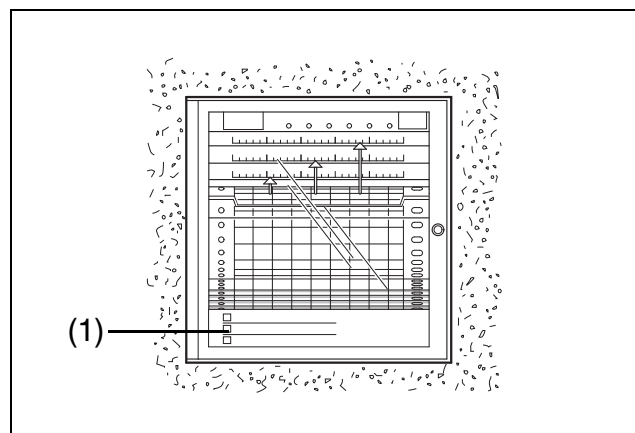

5 Starting up

5.4 Fitting the fibre pens

- * Open the recorder door
- * stop recording
(e. g. press key **S**)
- * Swing scale upwards
- * Slide the fibre pen into the holder
up to the stop
- * Swing scale down again

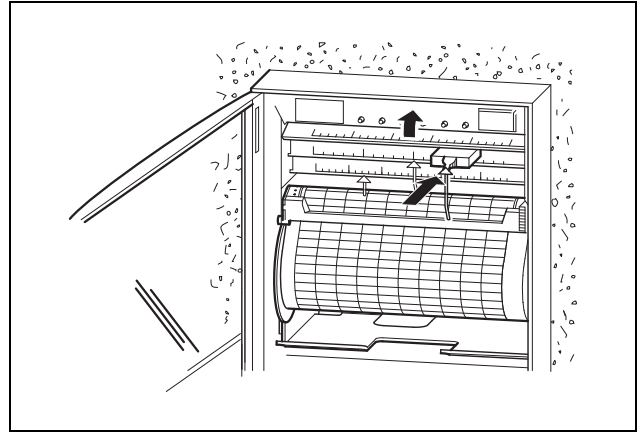

6 Preparation

6.1 Operating modes and status

Operating mode/status	Description
Basic status	<p>Basic status of the recorder with signal acquisition and processing. The display shows:</p> <ul style="list-style-type: none"> - time (can be switched off via the parameter <i>parameter level</i> → <i>display time</i>) - system error messages where appropriate. <p>In the stop status the display flashes "STOP". If there is a system error message, it is shown flashing at regular intervals instead of the time.</p>
Stop	
Stop by key	<p>Recording is stopped and continued using key S. In the stop status the display flashes "STOP".</p>
Stop via external stop	<p>External stop can be operated through a signal at a logic input on the back of the recorder. In the external stop status the display flashes "Stop".</p>
Chart speeds	
Normal chart speed	<p>The chart is advanced at the speed programmed under chart speed. ⇒ Section 8.3</p>
Limit operation	<p>When input goes above/below the programmed limits the recorder switches to the chart speed programmed under "limit feed". ⇒ Section 10.4</p>
External speed	<p>On a signal applied to a logic input at the back of the recorder it switches to the chart speed programmed under "feed extern". ⇒ Section 10.4</p>
Timed operation	<p>This chart speed applies within a programmable time period. Outside this period the chart is advanced at the speed programmed as normal speed. ⇒ Section 10.4</p>

6 Preparation

Operating mode/status	Description
Recording	
Scaling	The scale can be printed in two different modes: cyclic: for each channel at a configured spacing triggered: for all channels by pressing key (key F, hold down at least 4 sec) or by closing a logic input. ⇒ Section 7.4
Plotarea	During plotarea operation a portion of the total measuring range of a trace is recorded to a larger scale. ⇒ Section 10.4
Offset	Using the parameter “offset” it is possible to define the presentation range of a trace on the chart. ⇒ Section 10.4
Pen offset compensation	There is an offset of several millimetres between the fibre pens of the individual channels. When pen offset compensation is switched on, this pen offset is compensated automatically. ⇒ Section 10.4

6 Preparation

6.2 Operating principle

The individual parameters and functions are divided into three levels for clearer operation of the recorder.

Basic status

Basic status of the recorder with signal acquisition, recording and processing.

The display shows:

- time
(can be switched off via the parameter *parameter level* → *display time*)
- and system error messages where appropriate

If there is a system error message, it is shown flashing at regular intervals instead of the current display.

Operating level

At this level, signal acquisition and processing remain activated.

The following parameters can be altered at the operating level:

- chart speed
- print test
- service print

A summary of all parameters of the recorder is given in the Appendix (⇒ Section 12.6).

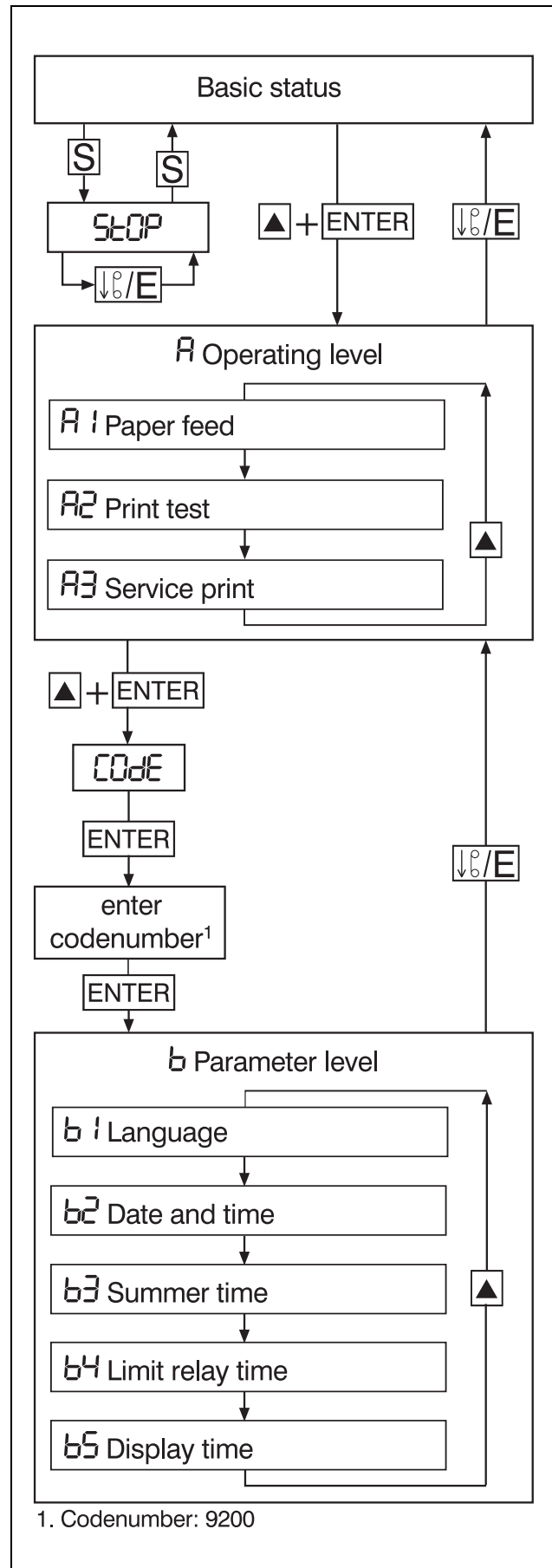

6 Preparation

Parameter level

The parameter level is protected by a code-number to prevent unauthorised access.

There are two different codenumbers:

- Codenumber for limited parameter set
- Codenumber for complete parameter set

 Section 8.6

If a wrong codenumber is input, the individual parameters can be viewed but can not be programmed.

Following input of the correct codenumber, the recorder interrupts signal acquisition and recording at this level. Statistical reports are re-started on leaving the parameter level.

 Section 7.9

The following parameters are altered at the parameter level:

- language
- date and time
- summer time
- relay limit
- display time

All other settings are made through the set-up program.

 Section 10.4

A summary of all parameters of the recorder is given in the Appendix.

 Section 12.6

6 Preparation

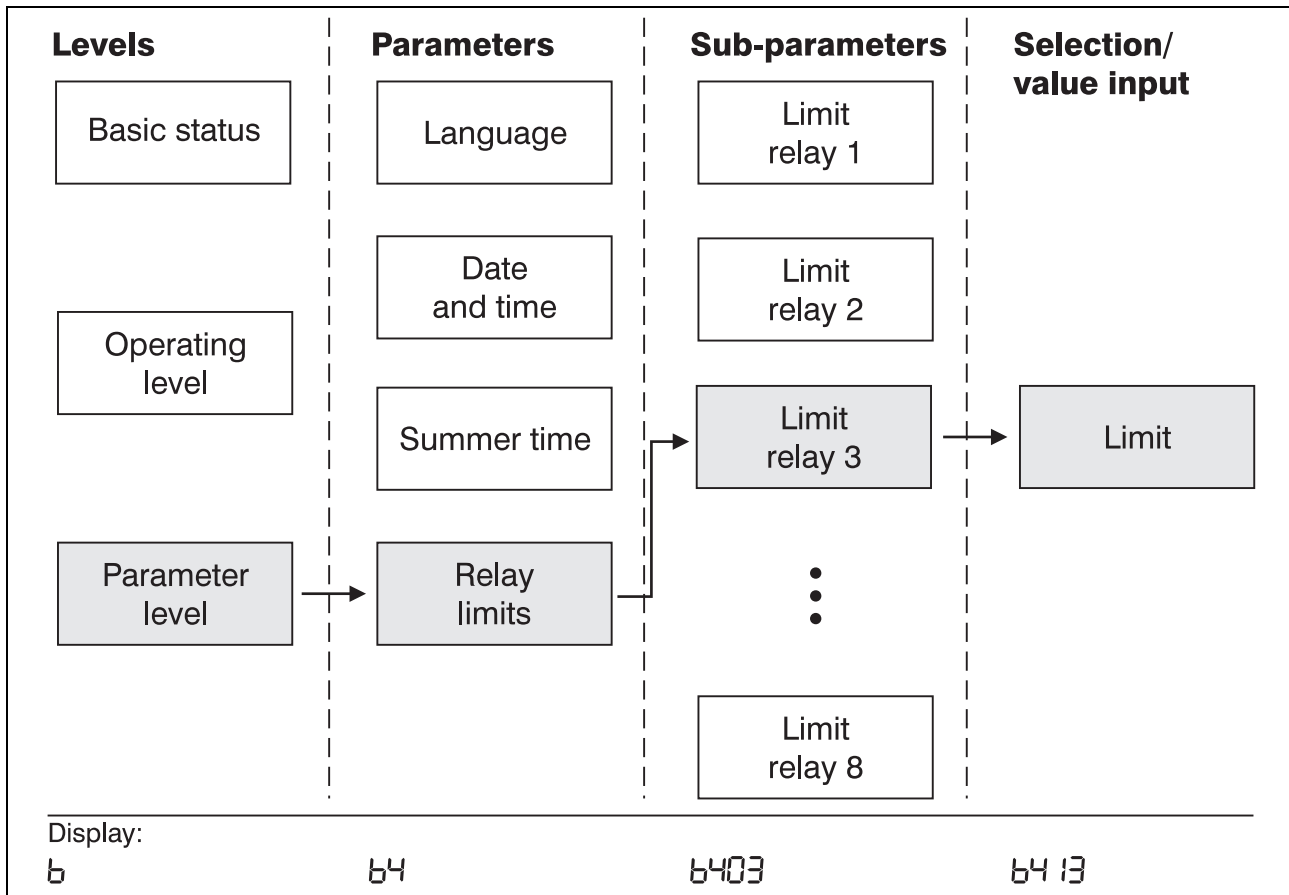

The levels, parameters and sub-parameters are arranged in a tree structure. Starting from the basic status the program branches to the individual levels and from there into the corresponding parameters, and also into any sub-parameters.

To alter a certain parameter, run through the relevant level up to this parameter.

The editing process is started with **[ENTER]**.

If a parameter has several sub-parameters, these are reached with **[ENTER]**.

Coding the parameters

The parameters and sub-parameters are indicated in code form on the 4-digit display. Coding involves up to 4 digits. The first digit is a letter, the others are numbers.

Digit	Description
1	A = operating level b = parameter level
2	indicates the parameter
3	indicates the sub-parameter
4	relay number

6 Preparation

Entering parameters

Where there are no further sub-parameters, **ENTER** transfers all the data of the parameter to the memory.

Aborting programming

Programming can be aborted within a parameter by pressing the key **↓P/E**.



If the last sub-parameter has not yet been entered, the parameter data which have already been edited are discarded. The old sub-parameters are retained.

Error messages during programming

If there are error messages during programming due to incorrect inputs, these have to be acknowledged with **ENTER** before programming can be repeated.

Key functions



↓P/E	<ul style="list-style-type: none"> - Chart fast forward when recording is stopped - Aborting parameter input (Exit) - Level change backwards
S	<ul style="list-style-type: none"> - Start/Stop recording - Decimal place selection during value input
F	<ul style="list-style-type: none"> - Function key for special function (hold down at least 4 sec) <p>factory setting: scale printout</p>
◀	<ul style="list-style-type: none"> - Move cursor left (select digit)
▲	<ul style="list-style-type: none"> - Parameter selection - Channel selection - Value selection from value table - Increment current digit
ENTER	<ul style="list-style-type: none"> - Initiate parameter input - Enter input - Acknowledge error message
▲ + ENTER	<ul style="list-style-type: none"> - Level change forwards

6 Preparation

Selection

Selection consists of a list of several options.



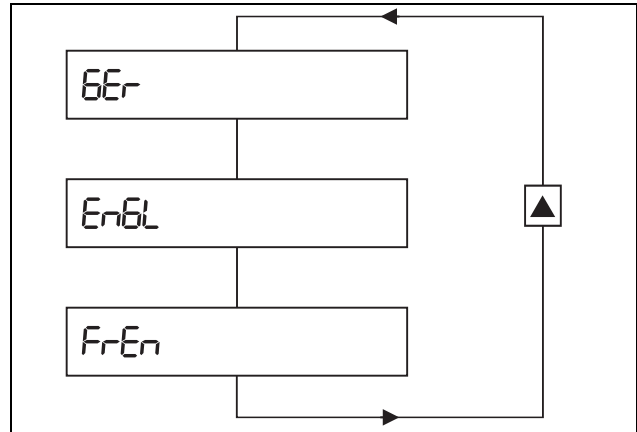

Two keys are used to select an option:

- * select option with the  key
- * enter selection with 



Value input

Three keys are used to input values:

- * select the digit to be altered with the  key
- * increment the selected digit with the  key
- * shift the decimal point with the  key
- * enter value input with 

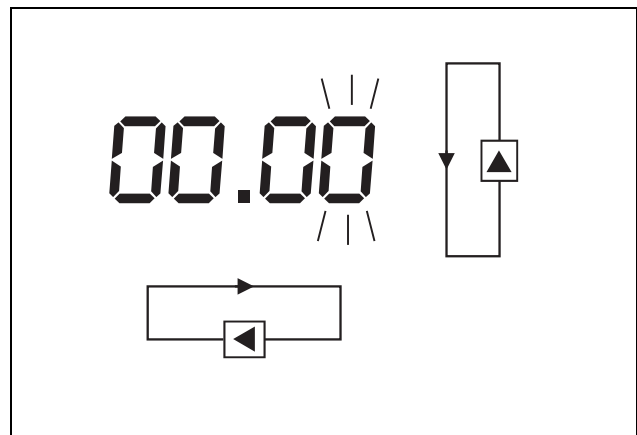

An incorrect input produces an error message on the display.

⇒ Section 12.2

The error message must be acknowledged with .

The value can then be entered again.

7 Text printing

The pen recorder can print text in addition to the trace using the fibre pen of channel 1. Text printing is used for comments on the trace and for event recording. The characters are written in dots on a 9 x 7matrix.

7.1 Printing priorities

There are various types of text which are assigned priorities in the setup program. These priorities determine abort criteria where printing of several texts is requested simultaneously.

The following applies in the explanations below:

- text 1 = text with high priority
- text 2 = text with low priority

If text 2 is being printed while there is a request for text 1, the printing of text 2 is interrupted and text 1 is printed.

If there is a request for text 2 while text 1 is being printed, text 2 is output after text 1 has been printed.

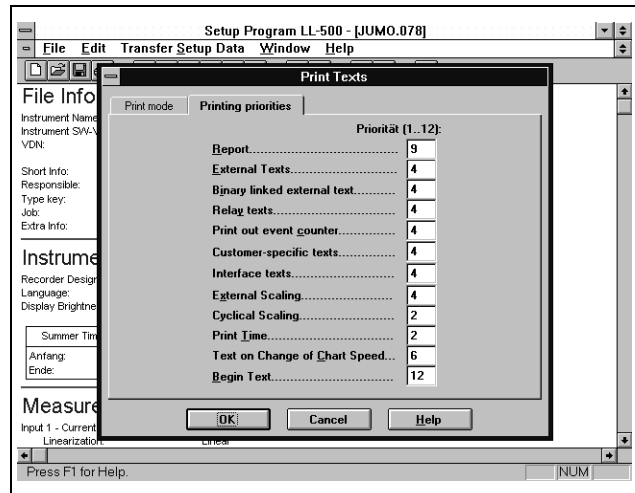

7 Text printing

Only the latest request is stored for each text.

Example:

A report with high priority is being printed from 12:00 to 12:05 hrs. While it is being printed a relay goes overlimit twice. Under normal conditions three texts would be printed for this overlimit (low priority), as follows:

“12:01 relay 1 ON”,

“12:02 relay 1 OFF” and

“12:03 relay 1 ON”.

In this example the printing of the report would first be completed. This is followed by the delayed output of

“12:02 relay 1 OFF” and

“12:03 relay 1 ON”.

Time	Text printing request	Actual printing
12:07		— “12:03 Relay 1 ON”
12:06		— “12:02 Relay 1 OFF”
12:05		
12:04		
12:03	“12:03 Relay 1 ON”	
12:02	“12:02 Relay 1 OFF”	
12:01	“12:01 Relay 1 ON”	
12:00	Report	

7 Text printing

In the following cases all existing text printing requests are cancelled and new ones received are ignored:

- recorder goes to stop status
- print test is started
- service print is started
- recorder is switched off

An exception is the statistical report:



Section 7.9

The following fixed priorities are allocated to stop, service print and print test:

Priority	Text
higher	<ul style="list-style-type: none">- Stop by key S, external stop, no chart, configuration by keys or setup- Service print- Print test- Text printing as configured in priority list
↑	
↓	
lower	

7 Text printing

7.2 Printing modes

There are two modes for printing text:

- trace is interrupted
- trace is overwritten

Interrupting the trace

The text is printed as quickly as possible. During text printing there is no recording of the trace on channel 1. The chart speed is optimised for text printing; it does not agree with the programmed chart speed.

The time for printing a text line is typically 10—40 sec.

Advantages:

- quick text printing
- minimum blockage of other messages
- text printing also at chart speeds above 360 mm/h
- text printing also when zero chart speed has been programmed

Disadvantages:

- channel 1 is not recording during text printing
- the chart speed is altered during text printing (time reference of channel 2 and channel 3 traces is no longer correct)
- if pen offset has been switched on, it is switched off during text printing. After text printing has been completed, the pen offset is switched on again and re-initialised.

7 Text printing

Overwriting the trace

The text is printed at the normal chart speed. There is only a brief interruption of the channel 1. There is no text printing at zero chart speed and at chart speeds above 360 mm/h.

Printing a text line requires different times depending on the programmed chart speed.

Chart speed	Printing time for one text line
5 mm/h	43 min approx.
20 mm/h	11 min approx.
120 mm/h	2 min approx.

Advantages:

- the time reference is retained during text printing
- recording of signals on channel 1 is only interrupted for a very brief time
- if pen offset has been switched on, it need not be switched off during text printing

Disadvantages:

- text printing may take a very long time
- there is no text printing at zero chart speed and at chart speeds above 360 mm/h

7 Text printing

7.3 Clock time

This is printed cyclically at a configurable spacing.

The following spacings can be set:

- 4 cm approx.
- 6 cm approx.
- 12 cm approx.
- no time printing

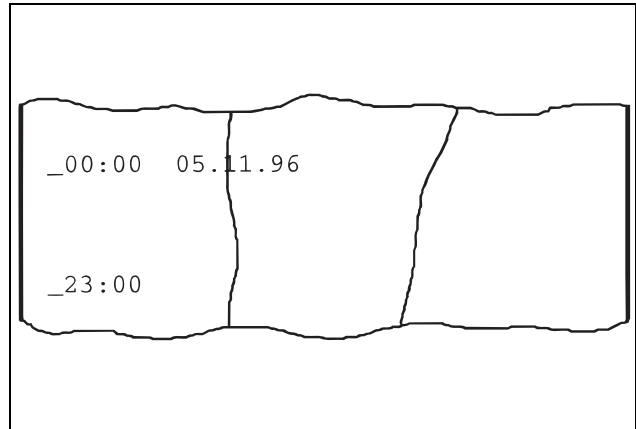

The spacings are independent of the selected chart speed. Clock time is only printed at even times and the spacings given above are only approximate.

Every fourth clock time print is followed alternately by the current chart speed, the programmed recorder designation, and the date.

The date is always printed on the date change at 00:00 hrs.

For an accurate time reference on the chart the clock time is preceded by a time reference mark (“_”).



If the symbol “?” is printed after the clock time, the time has to be checked and re-programmed if necessary (⇒ Section 8.9).

7 Text printing

7.4 Scaling

The scaling can be printed in two ways:

cyclic: for each channel at a configured spacing

triggered: for all channels on pressing the **F** key (hold down at least 4 sec) or by closing one of the logic inputs.

Cyclic scaling print-out

Spacings which can be selected:

- 30 cm approx.
- 60 cm approx.
- 90 cm approx.
- off

The lowest line shows the channel number, the corresponding pen colour, the programmed channel designation and the unit of the measured value.

If the range 0—100 mm has not been altered by offset, the next line shows the scale values for the 0 %, 50 % and 100 % lines. If the range has been restricted, this line contains marks for the start and the end of the range. The corresponding numbers are printed in the next line.

The limit marks for the current channel are printed in the top line.

7 Text printing

Example:

a) upper chart

- channel 1
- range: 0—100 mm
- relay limits at 200 and 500 °C

b) lower chart

- channel 2
- restricted range: 50—100 mm
- relay limit at 300 V

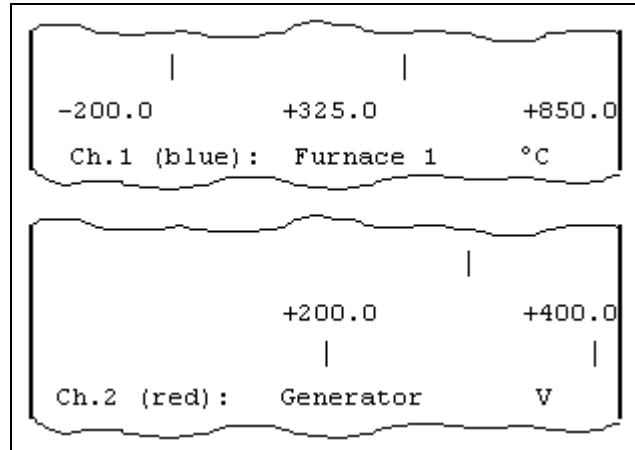

Triggered scaling print-out

To start the triggered scaling print-out the key **F** must be held down at least 4 sec.

Alternatively, the triggered scaling print-out can be started using a logic input.

The print-out covers the scaling of all channels whose writing status is switched on.

Print-out follows the same arrangement as described under “cyclic scaling print-out”.

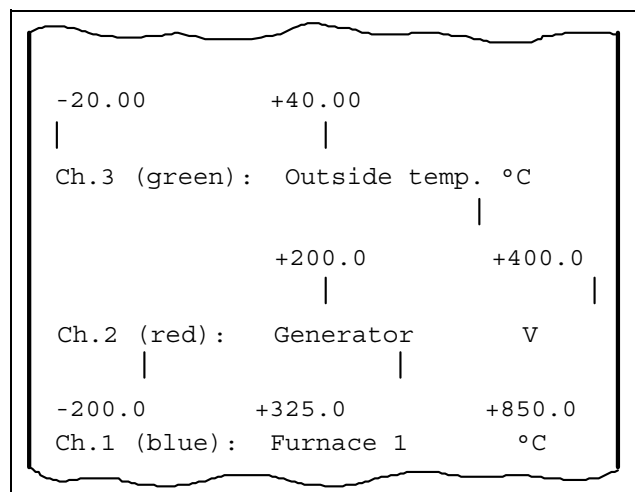

7 Text printing

7.5 Changing the chart speed

Every change in chart speed is reported by printing a line with the current time and the new chart speed.

The type of line indicates the type of chart speed with which recording takes place after the change.

- normal operation
- - - - - limit operation
- . - . - external speed
- timed operation

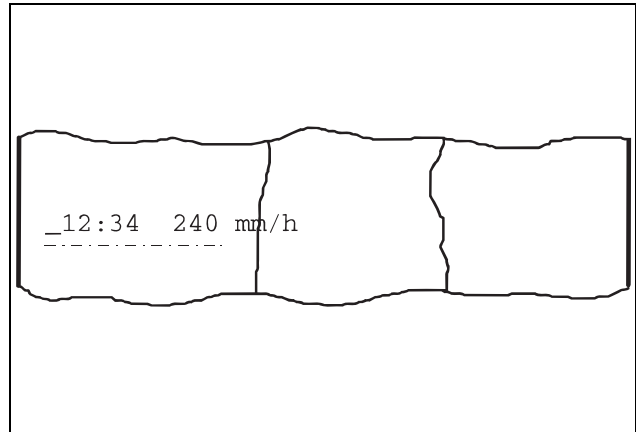

The individual events have different priority:

Event	Priority
limit operation	higher
external speed	↑
timed operation	↓
normal operation	lower

The current chart speed depends on the event with the highest priority.

⇒ Section 10.4

7 Text printing



Setting the printing priority for *Text on Change of Chart Speed* (⇒ Section 7.1) affects not only the printing of the chart speed change marking but also the change itself.

There is no chart speed change as long as a text with a higher priority is being printed.



Text printing in the trace overwriting mode (⇒ Section 7.2) may take a very long time.

In order that the chart speed change is not delayed, the priority of texts printed in this mode should be lower than the priority of the chart speed change.



The line to mark the type of speed change is printed even when the corresponding text can not be printed.

This is the case when the setup program has been configured under *Edit* ⇒ *Print out texts* in *Print mode* “*Process value overwrite*” for *Text on Change of Chart Speed*, and when a chart speed of zero or greater than 360 mm/h is set.



Text printing in the trace interrupting mode (⇒ Section 7.2) is comparatively quick.

In order to prevent the printing of texts in this mode being aborted through a chart speed change, the priority of these texts should be higher than the priority of the chart speed change.

7 Text printing

7.6 Recording start and end

Recording start and end are reported by a start and end text which can be programmed.

Text printing for start and end can be switched on and off separately.

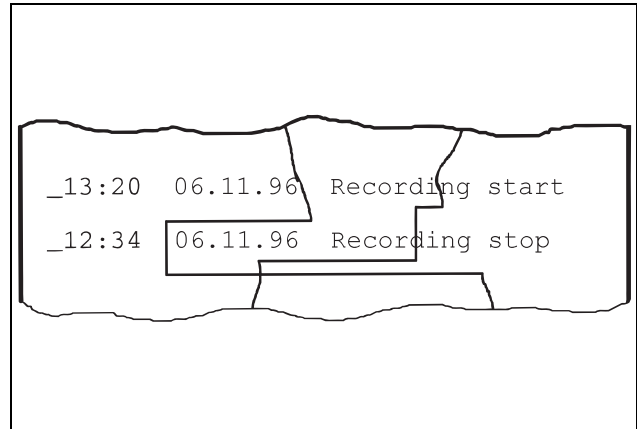

Section 10.4



The end text is being printed in the stop status in which no other text can be printed; there is therefore no priority and no trace interrupting/overwriting for the end text.



The start text should always have the highest priority to ensure printing at the start of recording.



Printing the end text is omitted when the chart sensor recognises "end of chart".



Printing the end text is aborted by pressing the  key.

7 Text printing

7.7 External text, binary-linked text, relay texts



Extra Code zf is required.

External text

Eight logic inputs are available for external texts.

Closing a logic input causes the corresponding text to be printed. Opening the logic input has no effect.

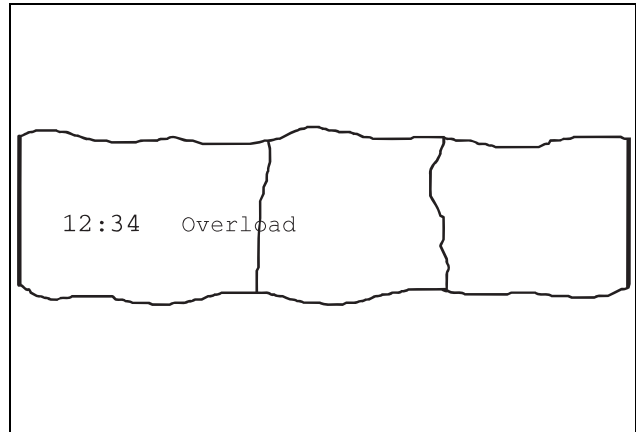

Binary-linked external text

It is possible to interpret the signals at the first 4 logic inputs as a binary number and to assign a text to each binary number. In this way it is possible to print up to 16 texts.

Following each change of status of these logic inputs the text corresponding to the binary number is printed.

Text printing can be switched off separately for each of the 16 texts.

Example:

If the state of the logic inputs is the binary number 1001, then text 9 is printed.

If the first logic input on the right is opened, the state of the logic inputs is the binary number 1000. Text 8 is being printed.

Binary number	Decimal number/ text
0000	0
0001	1
0010	2
0011	3
0100	4
0101	5
0110	6
0111	7
1000	8
1001	9
1010	10
1011	11
1100	12
1101	13
1110	14
1111	15

logic input 1

logic input 4

7 Text printing

Relay texts

Relay texts are printed when a relay switches.



The request for printing a relay text is ignored if the text consists only of blank characters. There is also no printing of the corresponding time.

Generally for external, binary-linked and relay texts:

In addition to the programmed text the time is printed when the text printing has been requested.



The time reference mark “_” (⇒ Section 7.3) is not being printed since printing may be delayed.



The texts can be configured through the setup program (⇒ Section 10.4).

7 Text printing

7.8 Incrementing the event counter

Any logic input is assigned to the event counter. Each closing of the corresponding logic input increments the event counter. It can be preset using the setup program.

Each incrementing is reported by printing the clock time and the programmed text, followed by the current counter reading.

⇒ Section 10.4

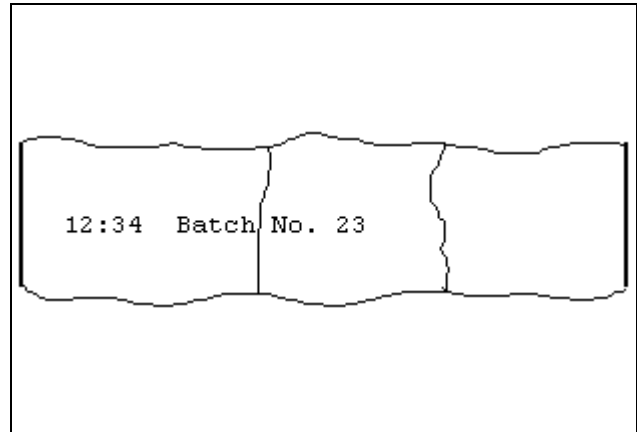

The time reference mark “_” (⇒ Section 7.3) is not being printed since printing may be delayed.



If the counter reading exceeds 9999 the number can no longer be shown. The counter reading is printed as “****”.

7 Text printing

7.9 Statistical report

This report is printed at the end of the statistical period. The statistical period is configured in the setup program.

⇒ Section 10.4

The texts “to”, “MIN”, “MAX”, “AVER.” and “DIM” are printed in the configured language. Only channels which are actually present and whose writing status is activated are included in the report.

If overrange or underrange has occurred during the statistical period, the minimum, maximum and average values are replaced by “-----”.

External report

The external report is compiled as soon as the corresponding (programmed) logic input is closed.

The report is printed as soon as the logic input is opened again.

Generally for the statistical report:

- If the recorder is switched off at the end of the statistical period, the report is cancelled.
The same applies if the recorder is re-configured from the keys or if the setup connector is plugged in.
- If printing of the statistical report is interrupted by stop, re-configuration, setup, or a print test or service print, printing the statistical report is not continued when recording is re-started.
- If the pen recorder is on stop when printing the statistical report should start, the report is printed after the stop is cancelled.
The statistic of a new report runs from the selected starting time for this new report, even if the printing of the old report should be delayed.

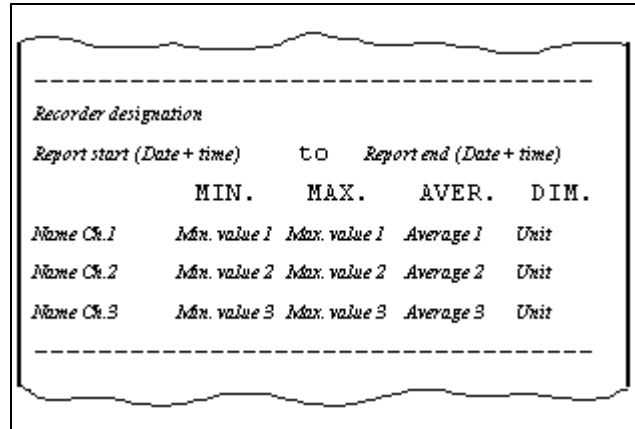

```
-----  
Recorder designation  
Report start (Date + time)   to   Report end (Date + time)  
      MIN.      MAX.      AVER.  DIM.  
Name Ch.1   Min. value 1 Max. value 1 Average 1 Unit  
Name Ch.2   Min. value 2 Max. value 2 Average 2 Unit  
Name Ch.3   Min. value 3 Max. value 3 Average 3 Unit  
-----
```

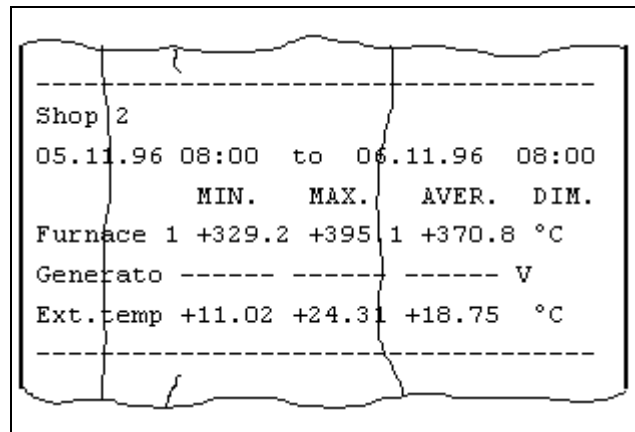

```
-----  
Shop 2  
05.11.96 08:00 to 06.11.96 08:00  
      MIN.      MAX.      AVER.  DIM.  
Furnace 1 +329.2 +395.1 +370.8 °C  
Generato ----- V  
Ext. temp +11.02 +24.31 +18.75 °C  
-----
```

7 Text printing

7.10 Print test

The print test can only be initiated on the recorder using the keys. It is used to check the function of writing system and fibre pens.



Started text printing is aborted and **not** continued after the print test.



All text printing requests arriving during the print test are rejected.

The only exception is the statistical report.

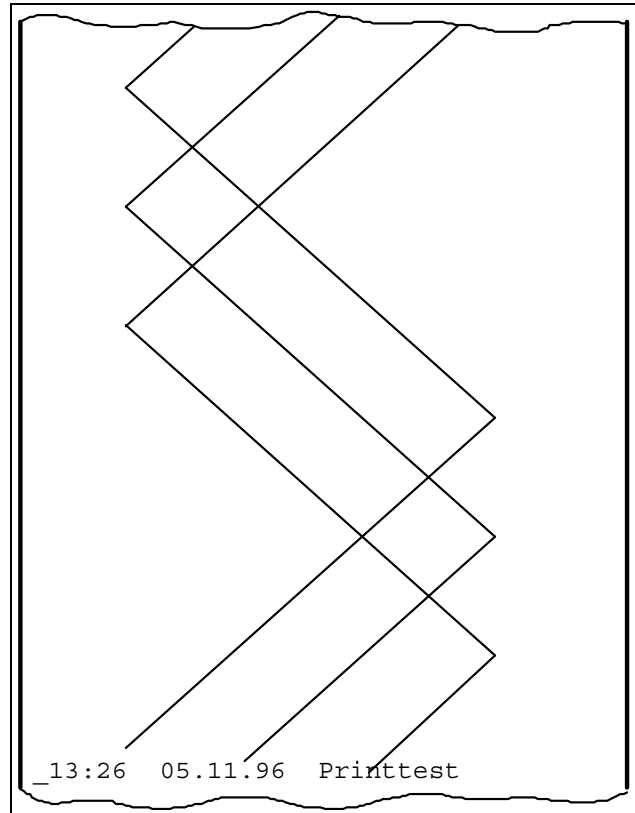

7 Text printing

7.11 Service print

The service print can only be initiated on the recorder using the keys.

It prints the software version, the number of supply interruptions and the total operating time of the recorder.



Started text printing is aborted and **not** continued after the service print.

```
-----  
SERVICE PRINT  
software version      : 078.02.01.1  
no. of power downs   : 00012  
operation time [h]    : 01234  
event counter 1      : +54321  
event counter 2      : -12345  
-----
```



All text printing requests arriving during the service print are rejected.

The only exception is the statistical report.



If the maths and logics module is activated, an “M” is printed after the software version.

8 Programming

8.1 Basic status

The recorder is in the basic status after the supply has been applied and it has been initialised. The measurement signals are acquired, processed and recorded.

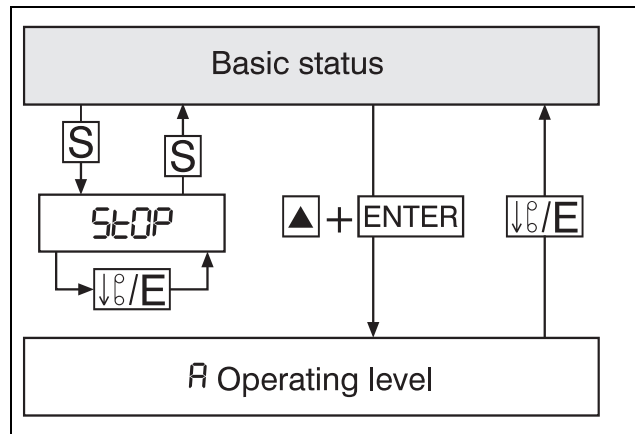

In the basic status the following are indicated:

- the clock time
(can be switched off via the parameter *parameter level* → *display time*)
- and system error messages as appropriate

Status messages and errors are flashing regularly instead of the current display.

Using the **S** key the recording is stopped and re-started. In the stop status the display flashes "STOP".

Pressing the **↓%/E** key in the stop status activates the chart fast forward.

Pressing the **F** key (hold down at least 4 sec) starts the scaling print-out.

Pressing the **▲** and **ENTER** keys simultaneously changes to the operating level.

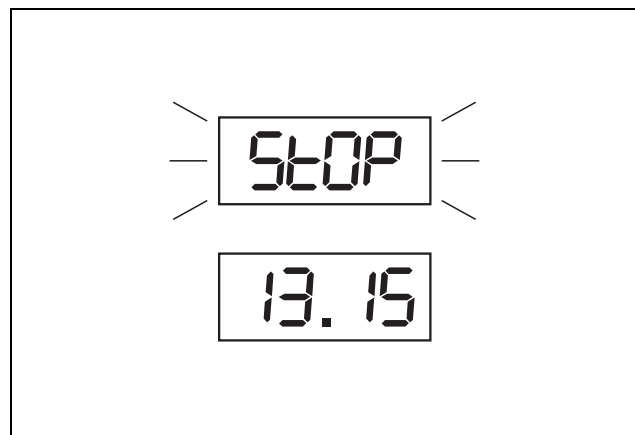

8 Programming

8.2 Operating level

The operating level is used to perform simple operating actions.

It is reached from the basic status by pressing the and keys simultaneously, from the parameter level by pressing the /E key.

The operating level is identified in the display by the letter "A".

The operating level includes the following parameters:

- chart speed
- print test
- service print



While the operating level is activated, signal acquisition, processing and recording as well as limit monitoring are continuing.

A summary of all parameters of the recorder is given in the Appendix (⇒ Section 12.6).

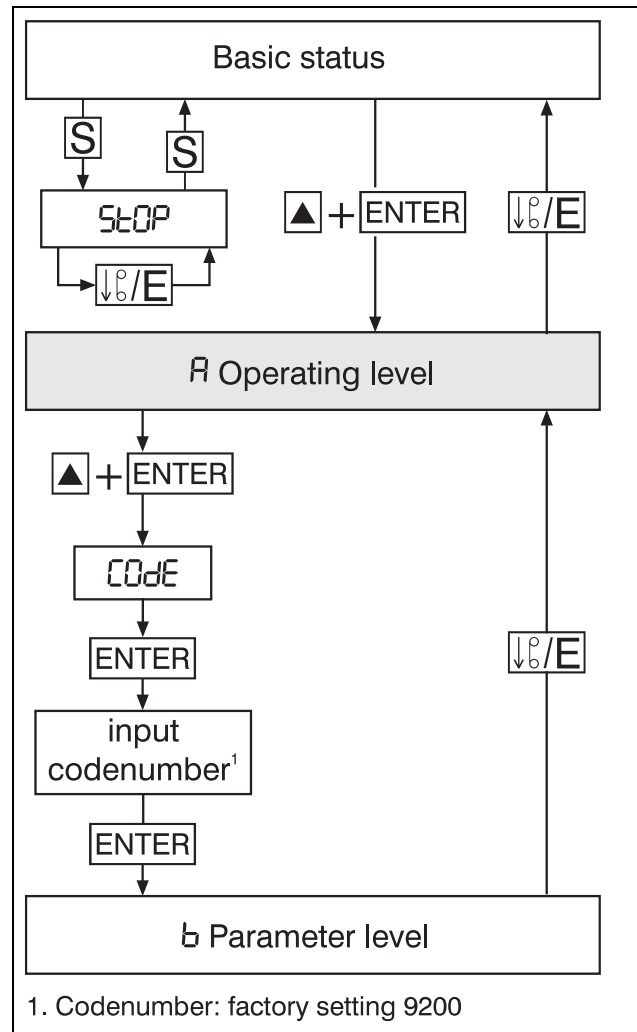

Display	Edit	Selection/input	with keys	Enter	Continue with
A					forwards

8 Programming

8.3 Chart speed

The standard chart speed for signal trace recording is set here.

The chart speed is selected in steps from a table of standard chart speeds, or can be programmed continuously to any value between 0 and 7200 mm/h.

Standard chart speeds are:

0, 5, 10, 20, 60, 120, 240, 300, 360, 600, 720, 1800, 3600 and 7200 mm/h.



The programming mode is factory-set to standard chart speeds.

In the setup program the programming mode can be changed to continuous under *Edit* → *Chart speed...*

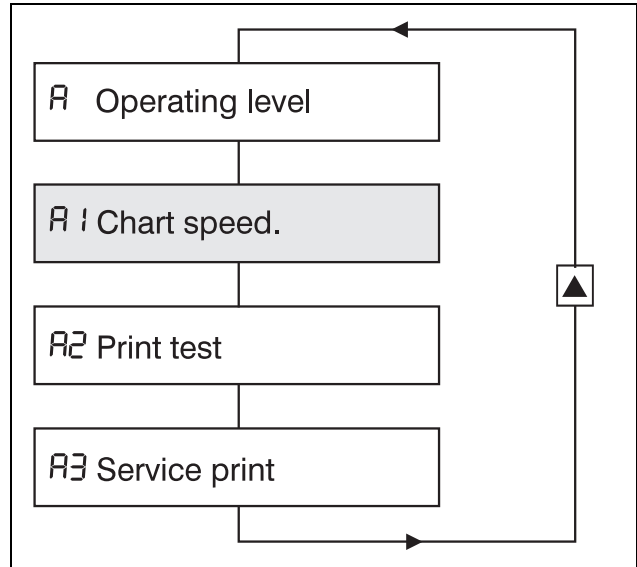

Please note Section 7.2

Display	Edit	Selection/input	with keys	Enter	Continue with
A1	<input type="text" value="ENTER"/> ⇒ with step speed programming:	240 select chart speed: 0, 5, 10, 20, 60, 120, 240, 300, 360, 600, 720, 1800, 3600 and 7200 mm/h	<input type="button" value="▲"/>	<input type="text" value="ENTER"/>	<input type="button" value="▲"/> forwards
	⇒ with continuous speed programming:	<u>0000</u> set required chart speed value range: 0—7200 mm/h	<input type="button" value="▲"/> , <input type="button" value="◀"/>	<input type="text" value="ENTER"/> test: speed value	<input type="button" value="▲"/> forwards

8 Programming

8.4 Print test

Print test is used to check the function of writing system and fibre pens.

Print test can only be initiated on the recorder using the keys.

 PRINTTEST = **On** continues until it is terminated by PRINTTEST = **OFF**.

 Started text printing is aborted and is not continued after the print test.

 All text printing requests arriving during the print test are ignored and rejected.
The only exception is the statistical report.

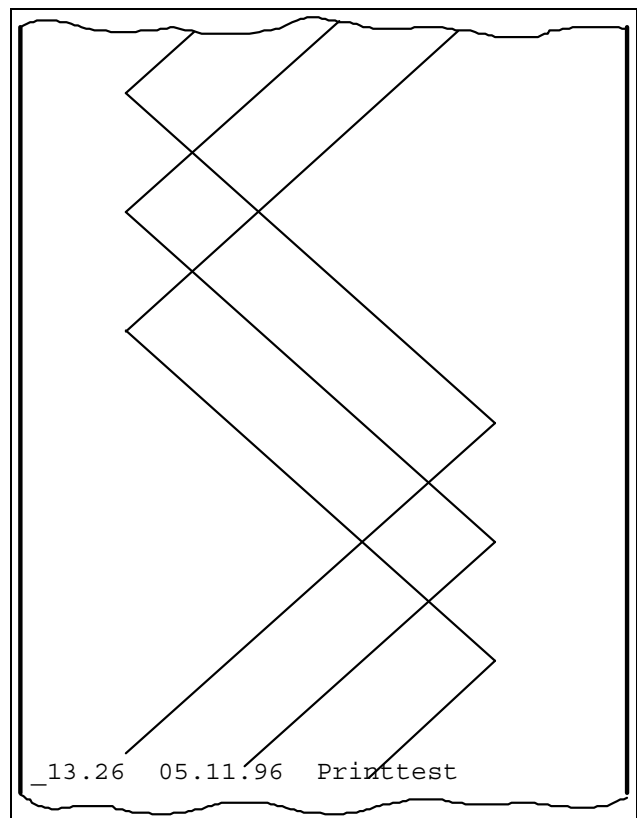
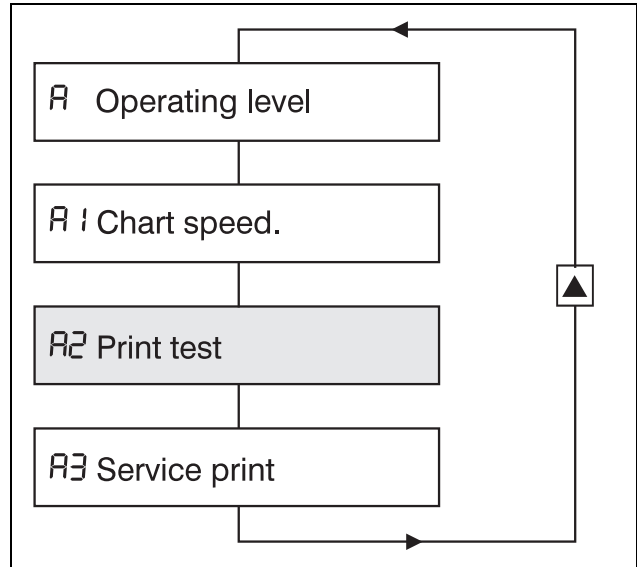

Display	Edit	Selection/input	with keys	Enter	Continue with
A2	<input type="text" value="ENTER"/>	OFF, On Select status of print test		<input type="text" value="ENTER"/>	forwards

8 Programming

8.5 Service print

The service print prints the software version, the number of supply interruptions and the total operating time of the recorder.

It can only be initiated on the recorder using the keys.

 Started text printing is aborted and is not continued after the service print.

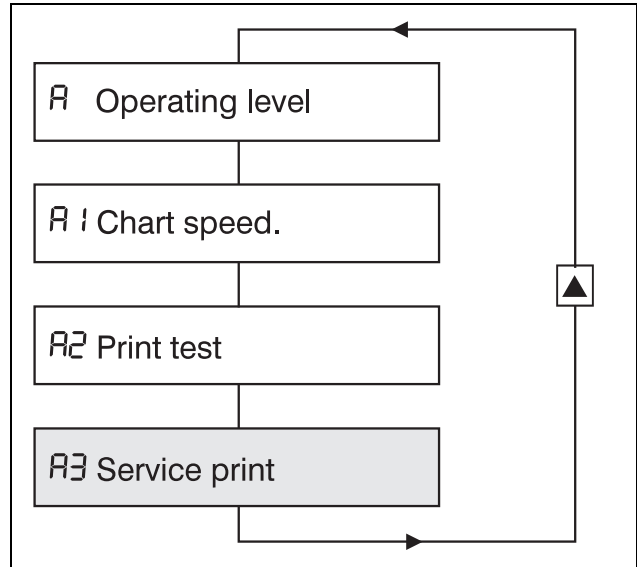

 All text printing requests arriving during the service print are ignored and rejected.

The only exception is the statistical report.

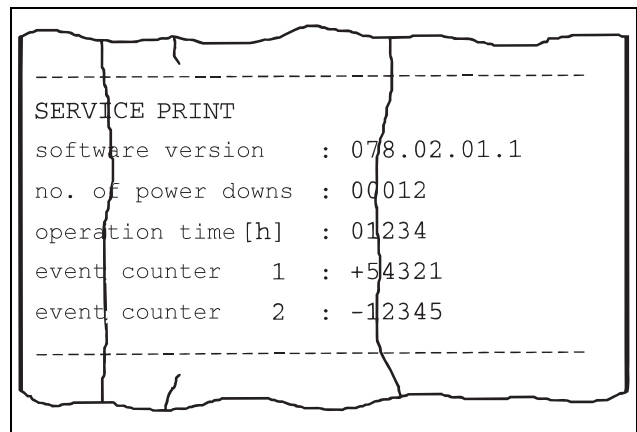

 If the maths and logics module is activated, an “M” is printed after the software version.

Display	Edit	Selection/input	with keys	Enter	Continue with
A3	ENTER	no, YES Service print no, yes	▲	ENTER	▲ forwards

8 Programming

8.6 Level inhibit and code request

The parameter level is protected by a 4-digit codenumber. There are two different code-numbers:

- The codenumber for restricted parameter set (factory-set to 9200).
- The codenumber for complete parameter set (factory-set to 9210).

The parameters which belong to the restricted parameter set are defined in the setup program, under *Edit* → *Operation*

Following entry of the correct codenumber the following are interrupted:

- signal acquisition, and
- recording

Additionally:

- events are no longer acquired,
- reports are aborted and reset,
- limit values are no longer monitored, and
- the outputs remain in their latest status.

The parameters can now be programmed.



If an incorrect codenumber is entered, the recorder remains in normal operation. Signal acquisition, processing and recording remain activated.

The parameters can be viewed but can not be programmed.



The codenumber can be altered in the setup program (*Edit* → *Codenumber*).

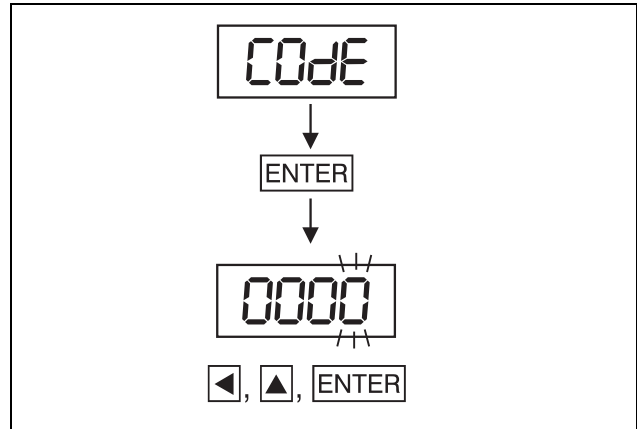

8 Programming

8.7 Parameter level

At the parameter level it is possible to configure general parameters.

From the operating level, the parameter level is reached by simultaneously pressing keys \blacktriangle and ENTER .

The parameter level covers the following parameters:

- language
- date and time
- summer time
- relay limit settings
- display time



If an incorrect codenumber is entered, the recorder remains in normal operation. Signal acquisition, processing and recording remain activated.

The parameters can be viewed but can not be programmed.



Following entry of a correct codenumber the normal operation is interrupted.

There is no signal acquisition, processing or recording.

The relays of the external relay module ER8 remain in their current status. They are only operated again when the recorder is at the operating level or in the basic status.

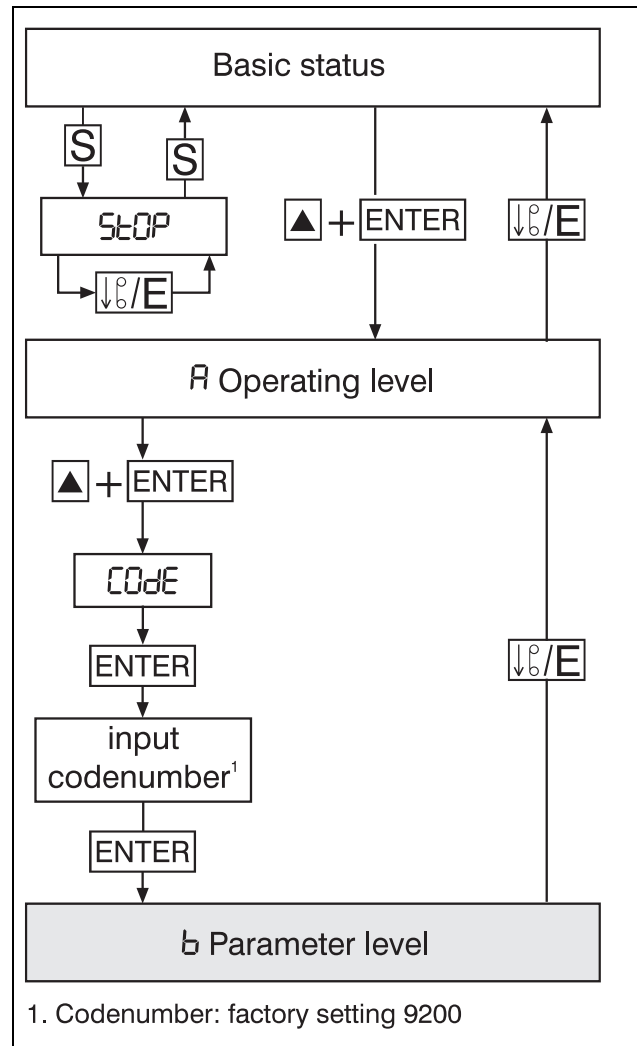

Display	Edit	Selection/input	with keys	Enter	Continue with
CODE	ENTER	0000 Input codenumber	\blacktriangle , \blacktriangleleft	ENTER	\Rightarrow 2
\Rightarrow 2 b					\blacktriangle forwards

8 Programming

8.8 Language

There is a choice of the following languages:

- English
- French
- German

The language setting affects all non-programmable texts in the recorder which are printed.

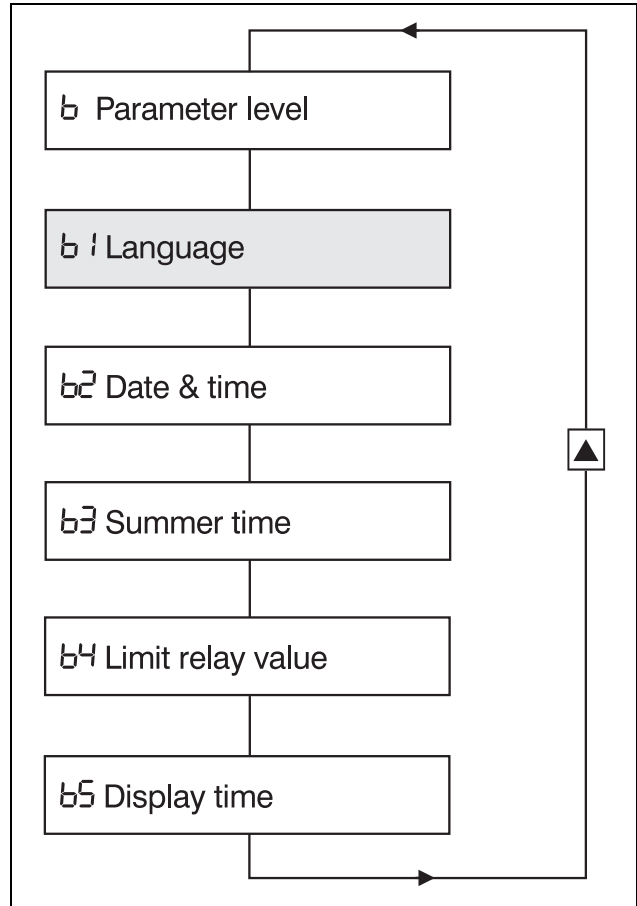

Display	Edit	Selection/input	with keys	Enter	Continue with
b1	ENTER	Select language: GEr (German) EnGL (English) FrEn (French)	▲	ENTER	▲ forwards

8 Programming

8.9 Date and time

Programming the system clock of the recorder. The following are programmed: day, month, year, weekday, hour and minute.

The current clock time is printed at certain events and is shown on the 4-digit display in the basic status.

It serves as reference time for timed events such as statistical reports, timed operation and summer time.

 Date and time are checked for plausibility after input. An error message is output where appropriate.

The error message is acknowledged with **ENTER** and the data can then be re-entered.

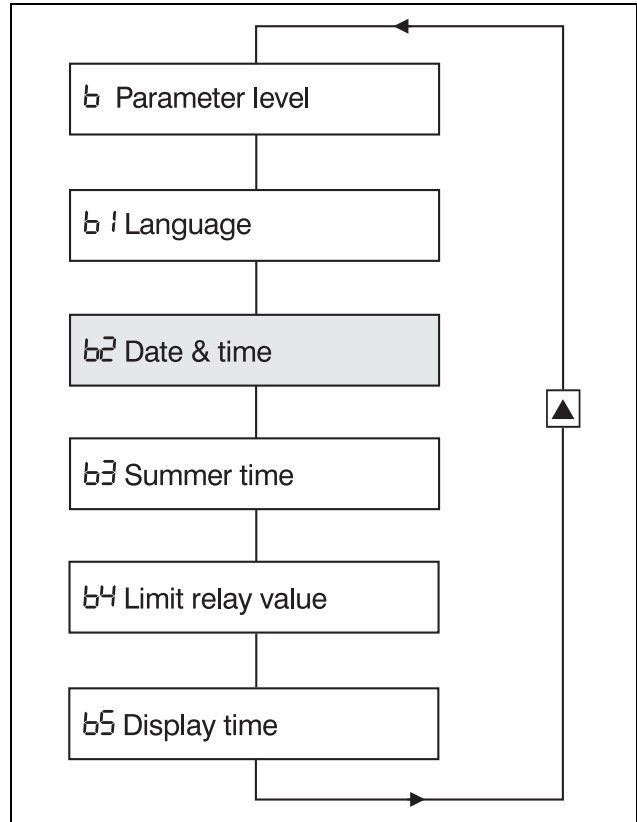

Display	Edit	Selection/input	with keys	Enter	Continue with
b2	ENTER				⇒ 2
⇒ 2 b2 1	ENTER	09.03. Input day and month: DD.MM.	▲, ◀	ENTER	⇒ 3
⇒ 3 b22	ENTER	96 Input year: YY	▲, ◀	ENTER Check date	⇒ 4
⇒ 4 b23	ENTER	1 Select weekday: 1 MONDAY 2 TUESDAY 3 WEDNESDAY 4 THURSDAY 5 FRIDAY 6 SATURDAY 7 SUNDAY	▲	ENTER	⇒ 5
⇒ 5 b24	ENTER	00.00 Input clock time: hh.mm	▲, ◀	ENTER Check time	▲ forwards

8 Programming

8.10 Summer time

Input of a time interval during which the system clock of the recorder is changed to summer time.

Example:

summer time start: 31.03.96, 2:00 hrs

summer time end: 27.10.96, 3:00 hrs

On 31.03.96 at 2:00 hrs the system clock is advanced automatically one hour to 3:00 hrs.

On 27.10.96 at 3:00 hrs the system clock is automatically put back one hour to 2.00 hrs.



The time interval for summer time always applies only to the period indicated.

It has to be re-programmed afresh for each year.

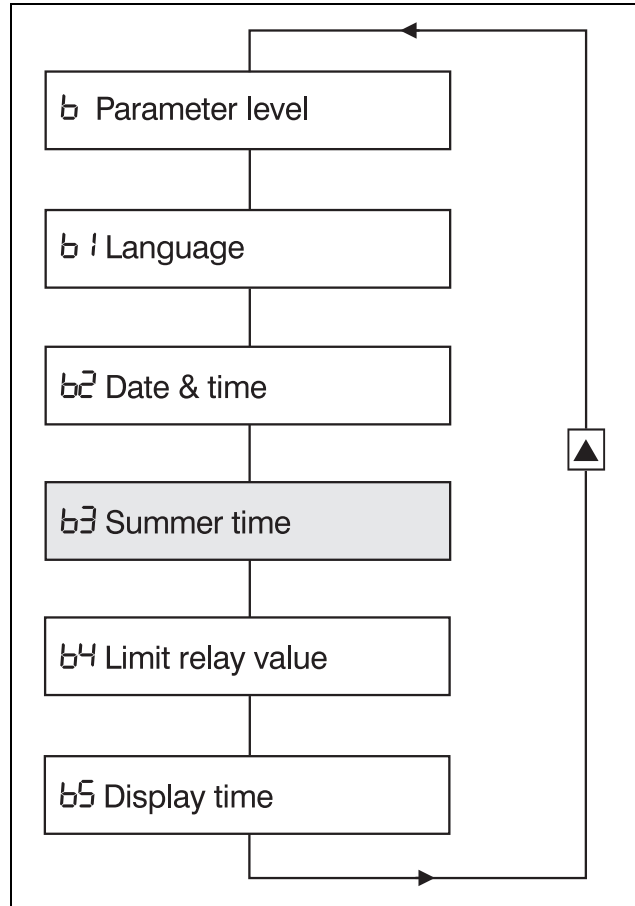

8 Programming

Display	Edit	Selection/input	with keys	Enter	Continue with
b3	ENTER				⇒ 2
⇒ 2 b31	ENTER	Off, On Input status	▲	ENTER	On ⇒ 3 Off: ▲ forwards
⇒ 3 b32 (On)	ENTER	<u>31.03.</u> Input date and month of start date DD.MM.	▲, ◀	ENTER	⇒ 4
⇒ 4 b33	ENTER	<u>96</u> Input year of start date YY	▲, ◀	ENTER Check date	⇒ 5
⇒ 5 b34	ENTER	<u>02.00</u> Input time for start hh.mm	▲, ◀	ENTER Check time	⇒ 6
⇒ 6 b35	ENTER	<u>27.10.</u> Input date and month of end date DD.MM.	▲, ◀	ENTER	⇒ 7
⇒ 7 b36	ENTER	<u>96</u> Input year of end date YY	▲, ◀	ENTER Check date	⇒ 8
⇒ 8 b37	ENTER	<u>03.00</u> Input time for end hh.mm	▲, ◀	ENTER Check time	▲ forwards

8 Programming

8.11 Relay limits



This parameter is only visible when the recorder is fitted with the interface for the external relay module ER8 (Extra Code zf is required).

For each relay a separate limit value is programmed at which it switches on or off.

The setup program also determines to which recorder channel the particular relay is assigned and whether limit monitoring is activated or not.

The switching differential to the left and right of the limit can be freely selected, also the limit comparator function (switch on or off at overlimit or underlimit lk7, lk8).



Section 10.4

Concerning lk7 and lk8



Section 10.3

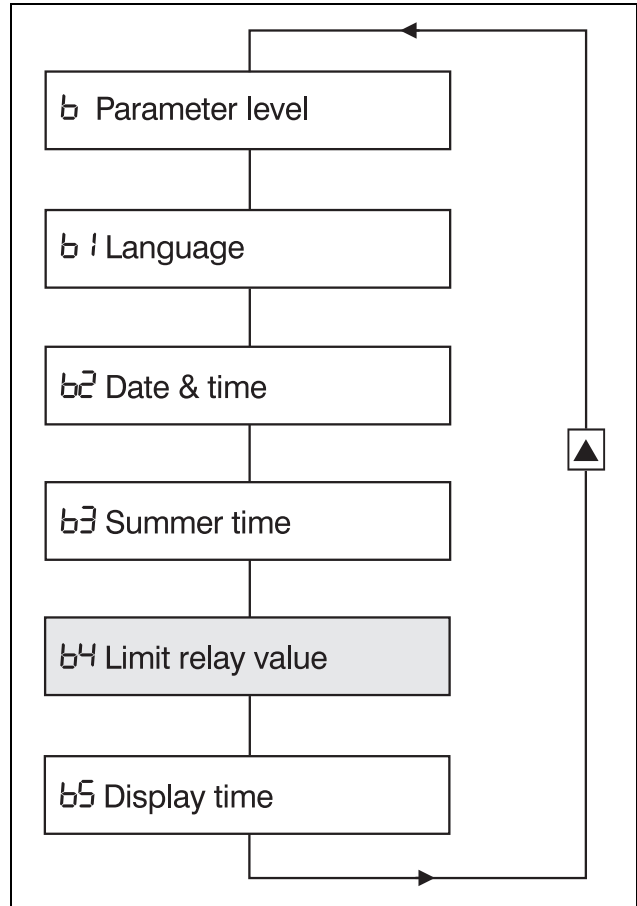

8 Programming

Display	Edit	Selection/input	with keys	Enter	Continue with
b4	ENTER	Select relay: b401 relay 1 b402 relay 2 b403 relay 3 b404 relay 4 b405 relay 5 b406 relay 6 b407 relay 7 b408 relay 8	▲	ENTER	⇒ 21 ⇒ 22 ⇒ 23 ⇒ 24 ⇒ 25 ⇒ 26 ⇒ 27 ⇒ 28
⇒ 21 b411 ⇒ 22 b412 ⇒ 23 b413 ⇒ 24 b414 ⇒ 25 b415 ⇒ 26 b416 ⇒ 27 b417 ⇒ 28 b418	ENTER	<u>0.000</u> Input limit value for relay	▲, ◀, S (decimal place)	ENTER	▲ forwards

8 Programming

8.12 Display of time

The parameter “Display time” has been added to the parameter level with effect from the instrument version 078.03.01.2.

The time is indicated on the display when the recorder is in the basic status. The time display can be suppressed (status = OFF) by using this parameter.



The instrument version can be determined by the parameter *Operating level* → *Service print*.

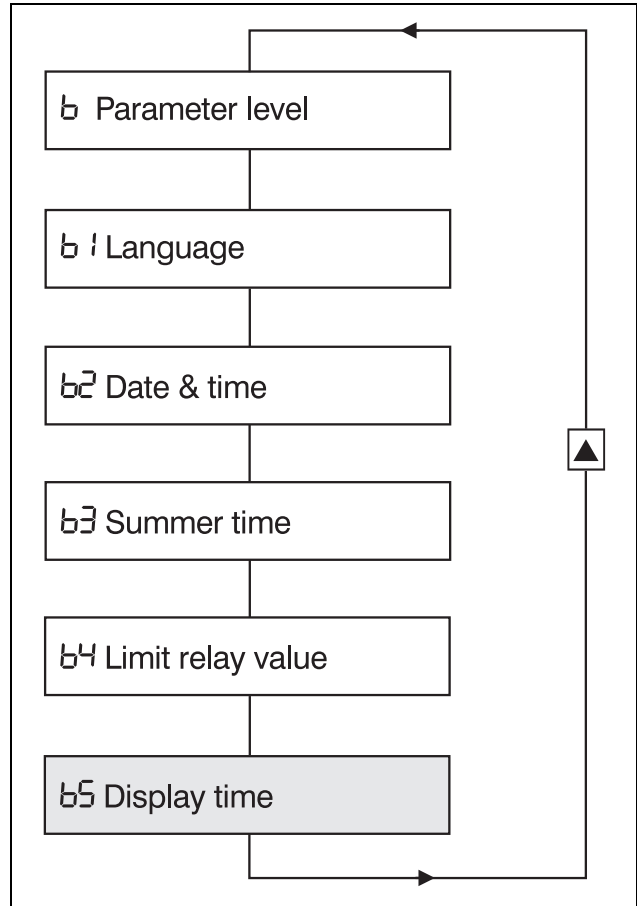

Display	Edit	Selection/input	with keys	Enter	Continue with
b5	ENTER	Off, ON Select status	▲	ENTER	▲ forwards

9 Consumables

9.1 Summary of consumables

Fibre pens, disposable

blue, Part No.: 00309750
red, Part No.: 00309751
green, Part No.: 00309753

Roll chart

overall width: 120 mm

no name, % graduation, linear

overall length: 16 m

Packing unit: 5 rolls

Part No.: 00331497

no name, % graduation, linear

overall length: 32 m

Packing unit: 5 rolls

Part No.: 00331499

no name, special graduation
(printing as order specification)

overall length: 16 m/32 m

Fanfold chart

overall width: 120 mm

overall length: 16 m

no name, % graduation, linear

Packing unit: 5 packs

Part No.: 00331490

no name, special graduation
(printing as order specification)

9 Consumables

9.2 Removing and replacing the chart cassette

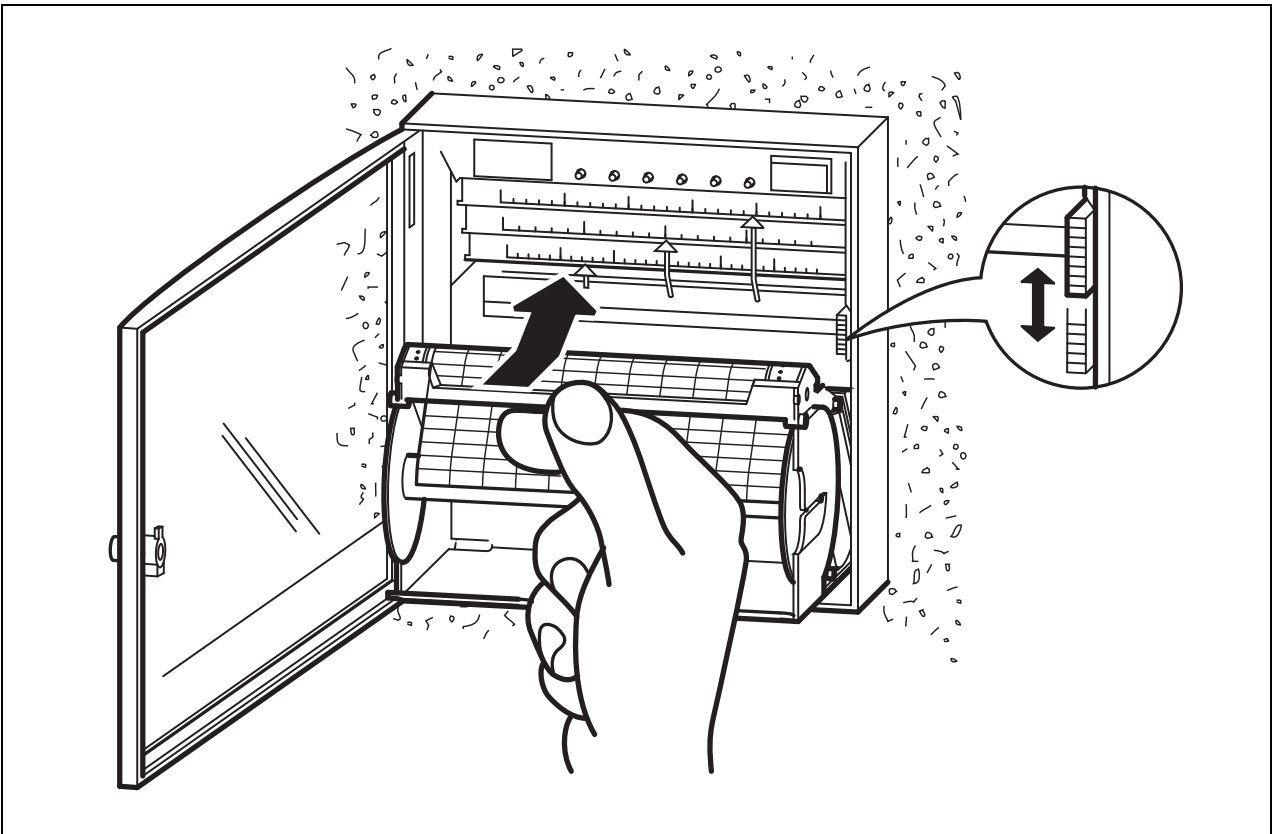
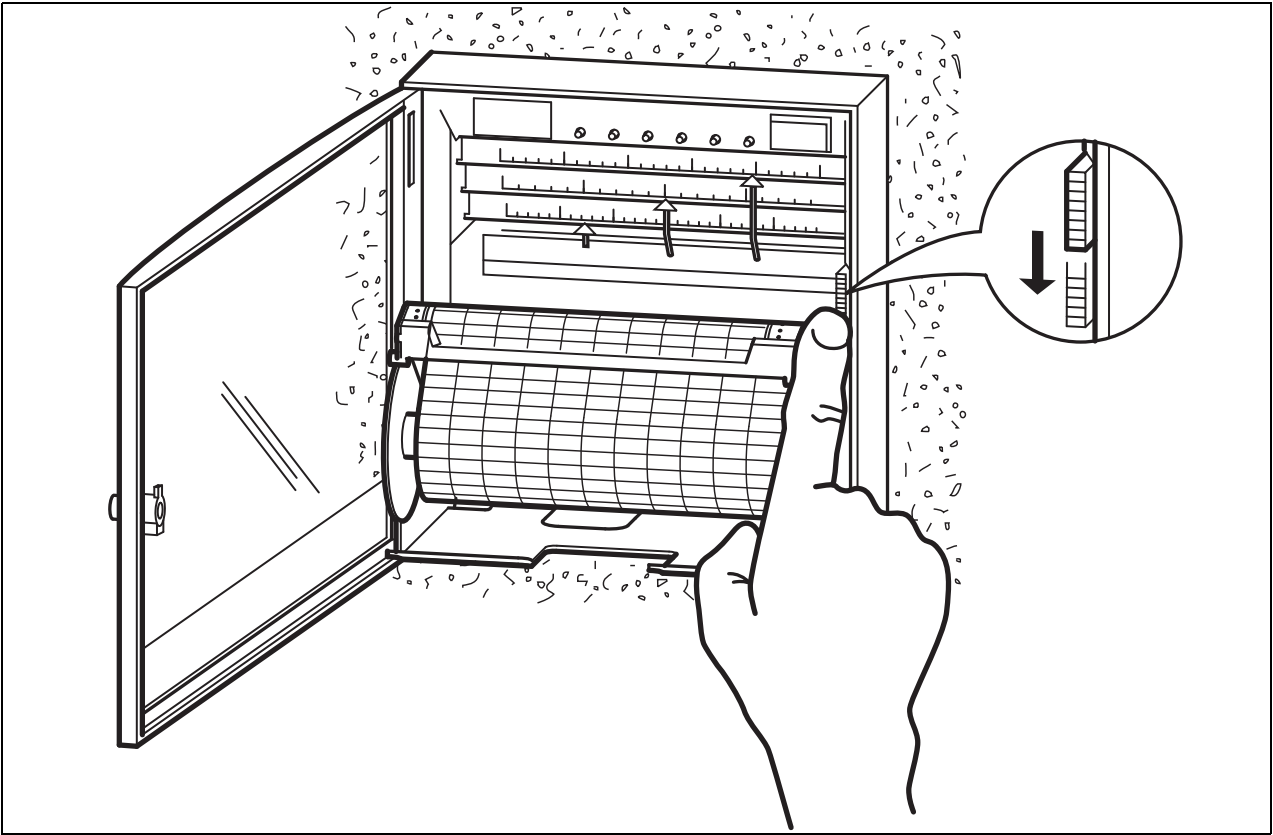

9 Consumables

- When inserting the chart cassette, take care that it is centered on the tear-off edge and – guiding it with the thumb and index finger – insert it into the cassette slot and push it up gently, until the holding/ejector catch snaps into position.
- When the cassette has been inserted, the paper feed should immediately take up the slack in the paper (about 10mm feed).
- If the paper feed does not start up, then the cassette will have to be removed and replaced in the correct position.
- Check that the holding catch is in the final (latched) position.

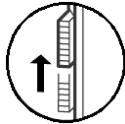

9 Consumables

9.2.1 Changing the roll chart

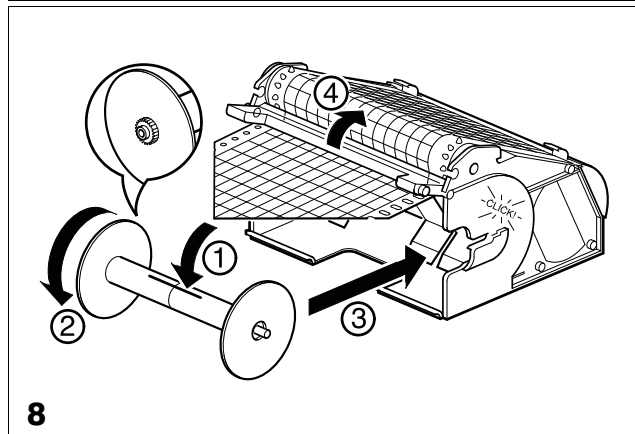
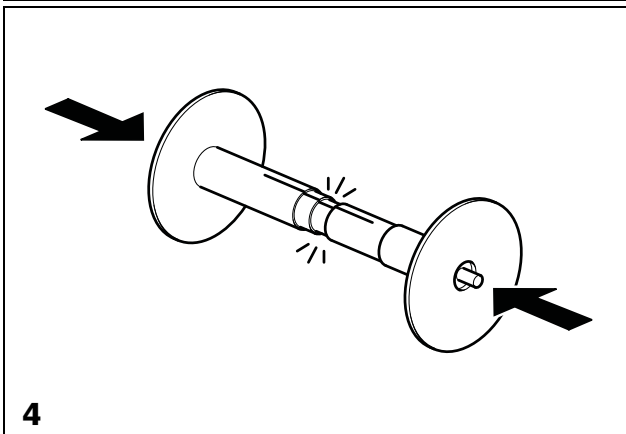
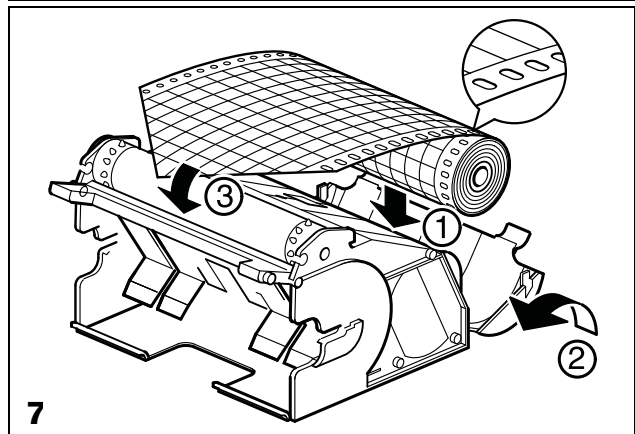
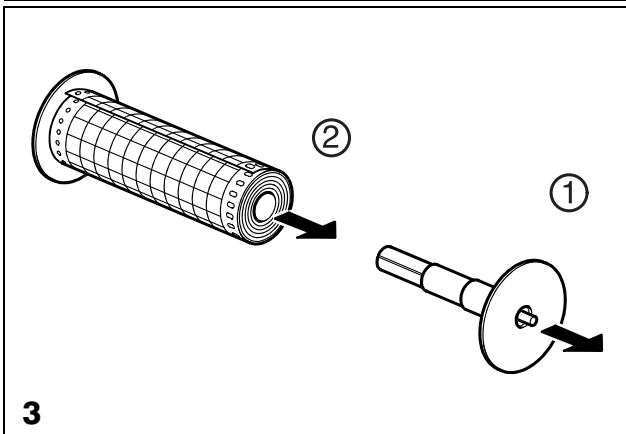
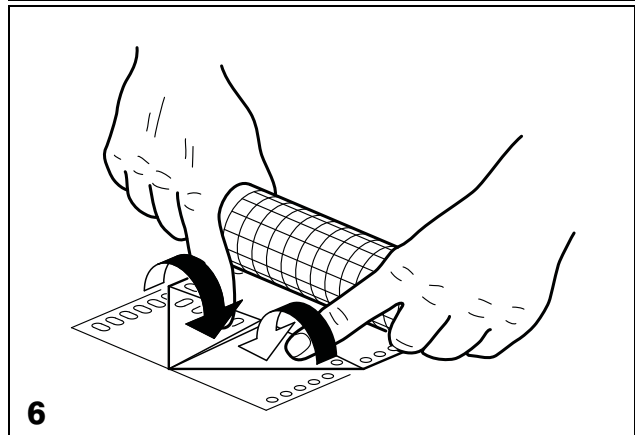
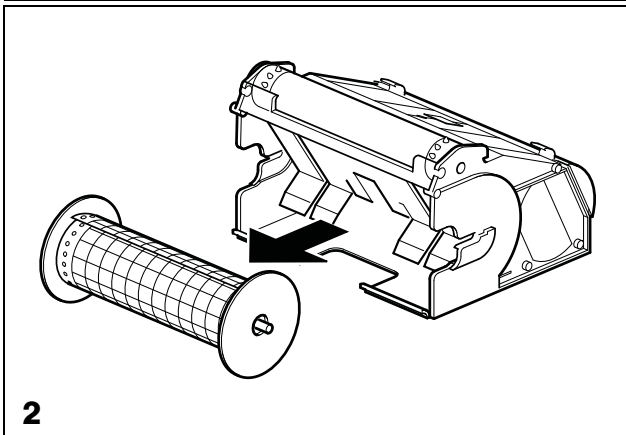
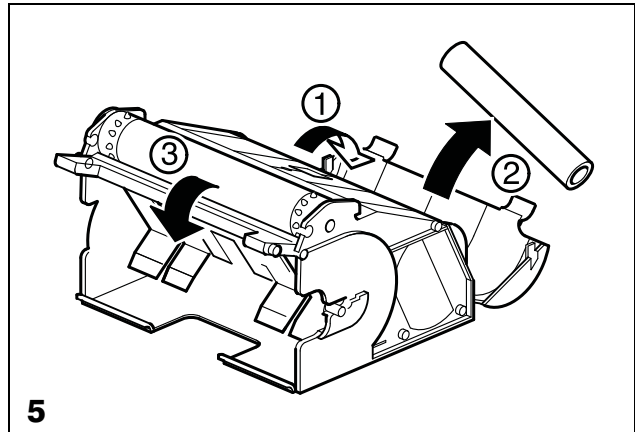
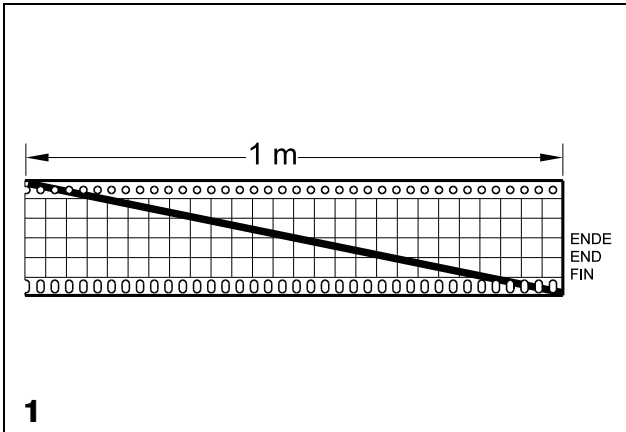

9 Consumables

9.2.2 Changing the fanfold chart

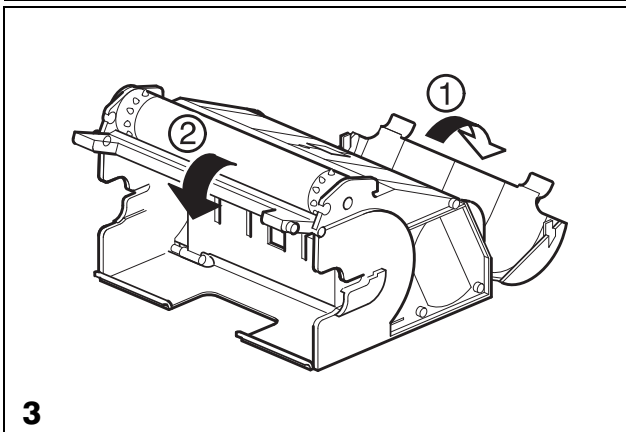
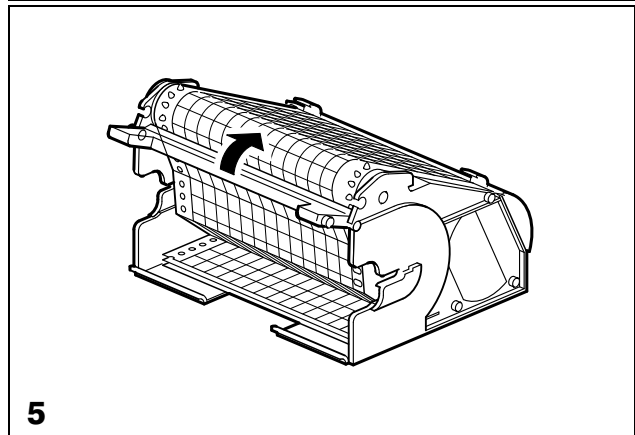
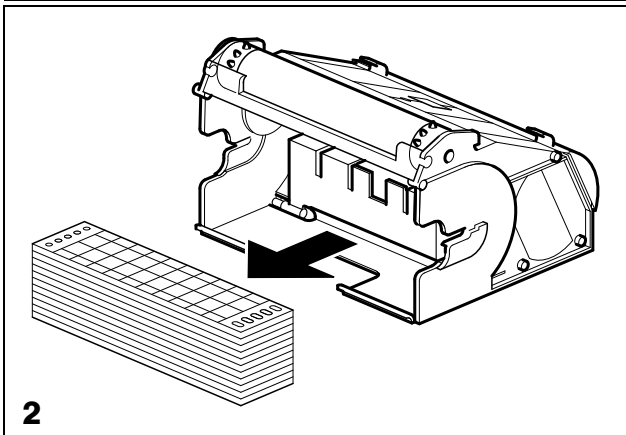
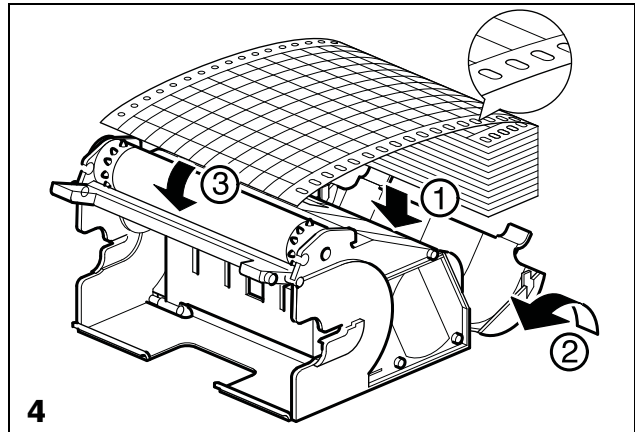
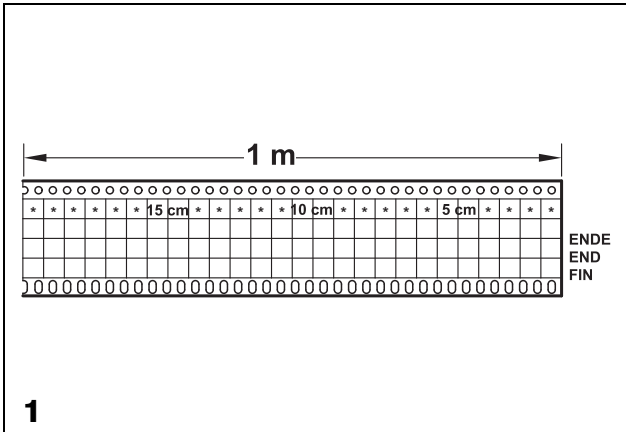

10 Extra Codes and accessories

10.1 Converting the chart cassette

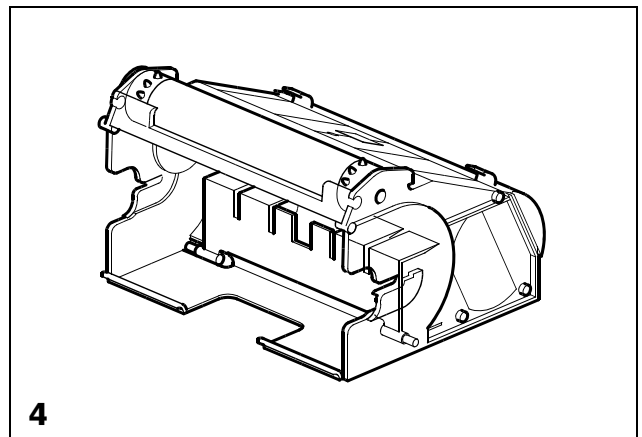
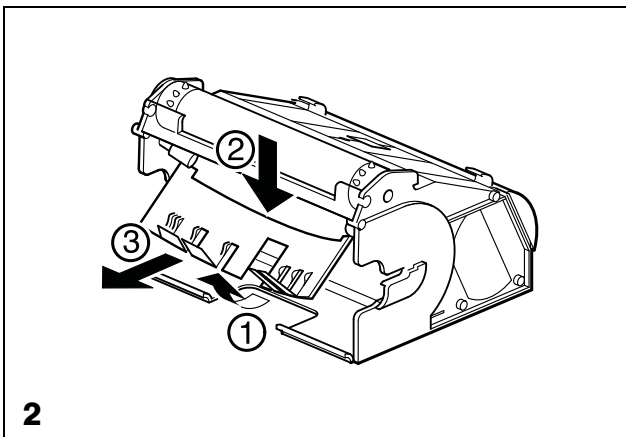
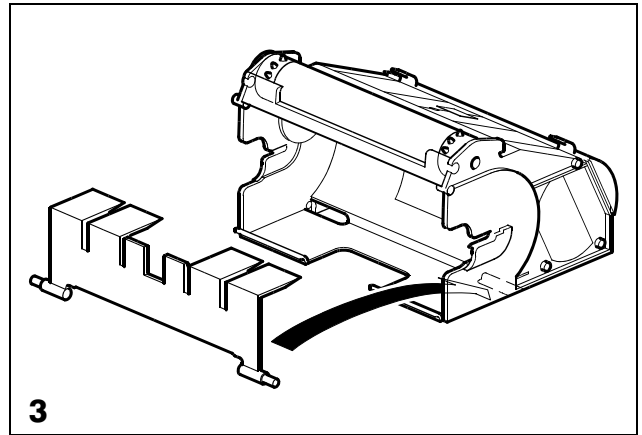
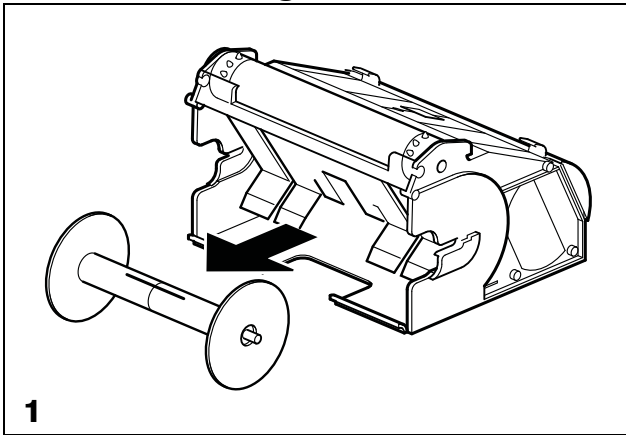

10 Extra Codes and accessories

10.2 Extra Code zf

The Extra Code zf provides eight logic inputs, an isolated supply for 2-wire transmitters, and the serial interface for the external relay module ER8.

The eight logic inputs can be operated by floating contacts or by the following voltage levels:

inactive 0 — 5V
active 20 — 35V

The voltage level must be applied for at least 0.5 sec.

Possible functions:

- external start/stop
- change chart drive over to external drive
- text printout
- start/stop of external report
- start scaling print
- event counter

10 Extra Codes and accessories

10.3 External relay module ER8

The external relay module ER8 adds eight switching outputs to the recorder. The relays are freely assigned to the recorder channels in the setup program (⇒ Section 10.4).

The limit for each relay is programmed at the parameter level.

 Section 8.11

The switching differential about the limit setting can be freely configured in the setup program. The limit comparator functions lk7 and lk8 are available.

 The external relay module ER8 can only be operated when the Extra Code zf is installed.

 When the setup connector is plugged into the recorder all relays are de-energised.

10 Extra Codes and accessories

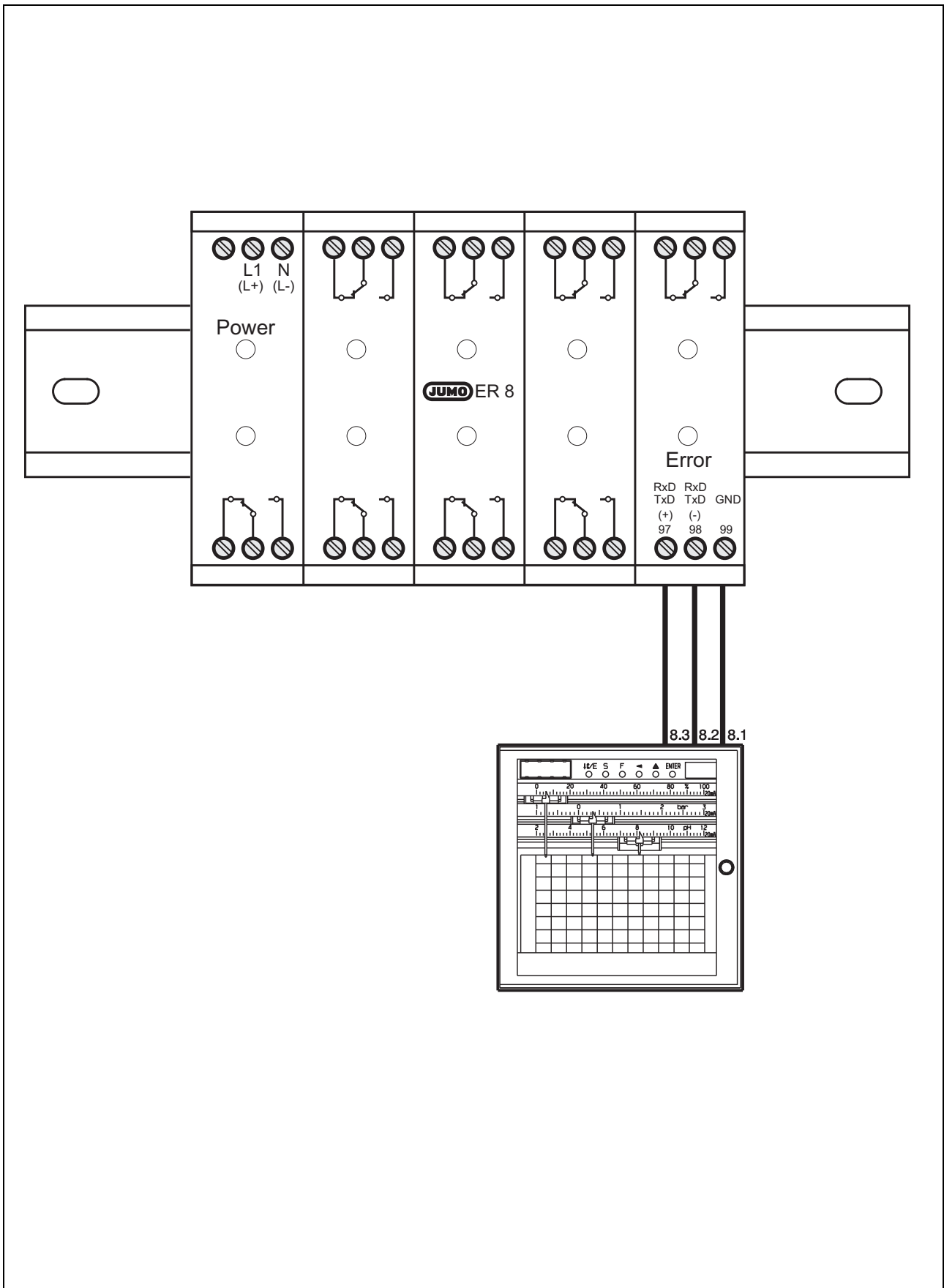

10 Extra Codes and accessories

Ik7

The relay is energised when the measurement goes above the limit setting.

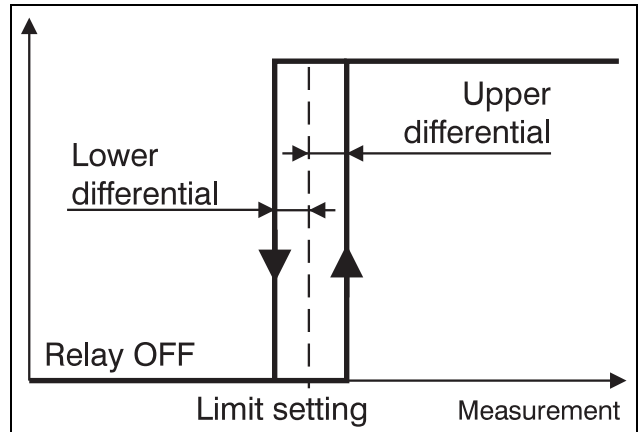

Ik8

as Ik7 but relay action reversed

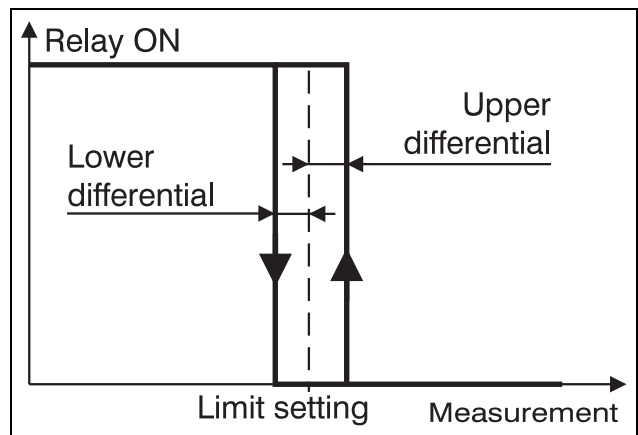

10 Extra Codes and accessories

10.4 Setup program

The setup program provides convenient configuration of the recorder using an IBM-PC compatible PC.

Hardware requirements:

- IBM-PC or compatible computer
- CPU from Intel 386
- 4 MB RAM
- 3.5" disk drive
- hard disk (at least 6 MB free)
- one free serial interface RS232 (data interchange)
- mouse
- VGA graphics

Software requirements:

- Microsoft Windows¹ 3.1x or above

The setup program is installed with an installation program for Microsoft Windows.

All parameters of the recorder can be programmed with the aid of the setup program.

A summary of all parameters of the recorder is given in the Appendix (⇒ Section 12.6).

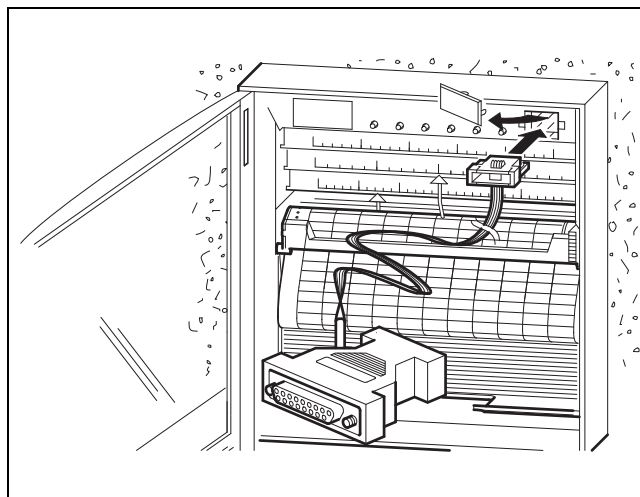
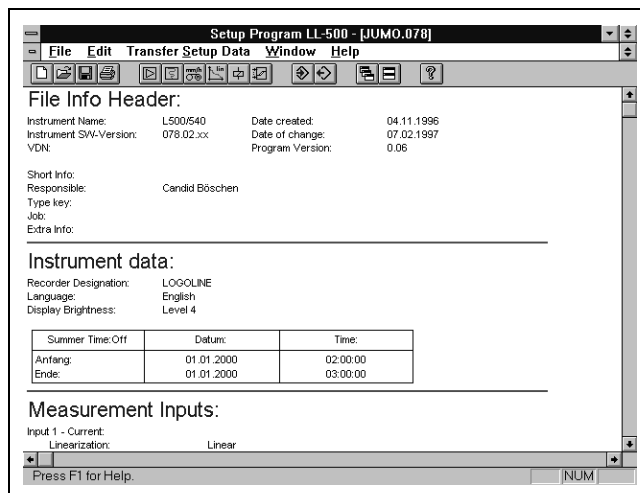

¹ Microsoft and Windows are registered trademarks of the Microsoft Corporation

10 Extra Codes and accessories



Plugging the setup connector into the recorder interrupts:

- signal acquisition and
- recording

In addition:

- events are no longer covered,
- statistical reports are aborted and reset,
- limits are no longer monitored, and
- the outputs are no longer operated; the relays are de-energised.

10 Extra Codes and accessories

10.5 Maths and Logics module

If the maths module is deactivated, then the signals which are present at the measurement inputs are recorded according to the configuration of the inputs.

If the maths module is activated, then the measured signals can be mathematically combined.

Example:

The sum/difference of two inputs is recorded on one channel. Simultaneously, on another channel, a maximum value is recorded for as long as a specific logic input is open. Closing the logic input instantly resets the maximum value recording.

Thanks to the many functions, operators and variables which are available for the maths module, an individual adjustment to the requirements of the task can be made in most cases.

On request, customer-specific maths programmes can be created at the factory.

The setup program is then used to transfer these programs to the chart recorder.

10 Extra Codes and accessories

10.6 Interface (RS422 / RS485)

This interface is intended for communication with higher-level systems (e.g. bus systems). It is **not** the setup interface, which is used to transfer data between the setup program and the chart recorder.

The RS422 / RS485 interface is described in detail in the Operating Manual B 70.6001.2.

11 Fault finding

11.1 What to do if...

<p>Display or printing “>>>>>>”</p>	<ul style="list-style-type: none"> - The value is outside the measuring range (Out Of Range) - The transducer has been connected up incorrectly - The signal inputs are configured incorrectly - Probe break
<p>Instead of a value, the printing or the display shows “****”, “±*.***”, “±**.**”, “±***.*”, “±****”.</p>	<ul style="list-style-type: none"> - The value can no longer be represented; alter the scaling with the setup program so that the value can always be represented. - In the case of event counter, reset the event counter using the setup program
<p>No recording</p>	<ul style="list-style-type: none"> - Key S has been pressed ⇒ Section 6.1 - “External stop” has been configured and the corresponding logic input is closed - The chart cassette has not been fitted correctly ⇒ Section 9.2 Caution: Insert the chart cassette by applying light upwards pressure - The take-up roll has not properly engaged with the chart cassette ⇒ Section 9.2.1 - The end of the chart has been reached ⇒ Section 9.2.1, Section 9.2.2. - The chart speed has been programmed as 0 mm/h ⇒ Section 8.3 - The writing status is “OFF” - The setup connector is still plugged in
<p>Fibre pen does not write</p>	<ul style="list-style-type: none"> - The fibre pen has not been fitted correctly ⇒ Section 5.4 - The ink in the fibre pen is used up
<p>No chart feed</p>	<ul style="list-style-type: none"> - The chart cassette has not been fitted correctly ⇒ Section 9.2 - The chart speed has been programmed as 0 mm/h - The pin roller does not engage with the chart perforations - The tear-off edge is not correctly engaged - The pen recorder is in the STOP status - With a newly inserted chart, the start of the chart must be straight and smooth so that the chart can be taken up automatically
<p>Measurements are not recorded</p>	<ul style="list-style-type: none"> - Check that the connecting terminals are tightened properly - Check the supply - Check the input configuration (range) - Check the transducers and their cables, measure them where appropriate - The write status may be switched off

11 Fault finding

Relay does not switch although limit is exceeded	<ul style="list-style-type: none">- The signal inputs are not wired up according to the connection diagram- Pen recorder and external relay module ER8 are not connected together correctly- The switching differential at the limit has been disregarded- The relay status is "OFF"- A wrong signal is being monitored against the limit
No programming possible	<ul style="list-style-type: none">- A wrong codenumber has been input- The codenumber has been altered with the setup program
No communication with the setup program	<ul style="list-style-type: none">- The setup connector has not been plugged in correctly- The recorder is already being configured using the keys; leave parameter level by pressing the  key.

12 Appendix

12.1 Technical data

Analogue inputs (measurement channels)

Measurement time

240 msec for all three channels

Input filter

digital second-order filter

filter time constant adjustable 0 — 10.0 sec.

Thermocouples

Type	Range limits	
Fe-Con L	-200	+ 900 °C
Fe-Con J	-210	+1200 °C
Cu-Con U	-200	+ 600 °C
Cu-Con T	-270	+ 400 °C
NiCr-Ni K	-270	+1372 °C
NiCr-Con E	-270	+1000 °C
NiCrSi-NiSi N	-270	+1300 °C

shortest span: 100 °C

Accuracy of measurement:

±0.1 % referred to range limits. On Type J this applies only from -200 °C upwards, on Types U and T only from -150 °C, on Type K only from -80 °C and on Types E and N only from -100 °C upwards.

Type	Range limits	
Pt10Rh-Pt S	-50	+1768 °C
Pt13Rh-Pt R	-50	+1768 °C
Pt30Rh-Pt6Rh B	0	+1820 °C

shortest span: 500 °C

Measurement accuracy:

±0.15% referred to range limits. On Typ B this applies only from 400 °C upwards, on Types S and R only from 0 °C upwards.

Within the range limits the start and end of range can be freely programmed in 0.1 °C steps.

Cold junction

internal: Pt100

Accuracy of internal cold junction: ±1.0 °C

external: cold junction thermostat

The cold junction temperature is set in the setup program to a constant value between -50 and +100 °C.

external: Pt100 in 3-wire circuit

Resistance thermometers

Type	Range limits		Linearisation
Pt100	-200	+850 °C	IEC
Pt100	-200	+649 °C	JIS
Pt500	-200	+850 °C	IEC
Pt1000	-200	+850 °C	IEC
Ni100	-60	+180 °C	

shortest span: 15 °C

Measurement accuracy:

Range	2-wire		4-wire
	3-wire		
-200 +100 °C	±0.4 °C		±0.4 °C
-200 +850 °C	±0.8 °C		±0.5 °C

Within the range limits the start and end of range can be freely programmed in 0.1 °C steps.

lead resistance:

3-wire circuit 30 W max. per lead

2-wire circuit 15 W max. per lead

measurement current:

0.4 mA on Pt100 and Ni100

0.05 mA on Pt500 and Pt1000

Resistance transmitters with 3-wire connection

3.9 kW max.

min. span: 6 W

12 Appendix

Measurement accuracy:

up to 130 W : ± 150 mW

up to 390 W : ± 300 mW

up to 1600 W : ± 1.6 W

up to 3900 W : ± 2 W

The resistance can be programmed in 0.1W steps.

Potentiometers in 2-wire, 3-wire and 4-wire circuit

3.9 kW max.

min. span: 6 W

Measurement accuracy:

up to 130 W : ± 150 mW

up to 390 W : ± 300 mW

up to 1600 W : ± 1.6 W

up to 3900 W : ± 2 W

The resistance can be programmed in 0.1W steps.

Voltage

Voltages can be measured in the following basic ranges:

Basic ranges	Measurement accuracy
-15 + 77 mV	± 80 mV
0 + 170 mV	± 120 mV
-76 + 76 mV	± 120 mV
-162 + 880 mV	± 1 mV
0 + 1930 mV	± 1 mV
-880 + 880 mV	± 1 mV
-1.84 + 10 V	± 6 mV
0 + 22 V	± 12 mV
-10 + 10 V	± 12 mV

shortest span: 5 mV

Within these basic range limits the start and end of range can be freely programmed, up to 999 mV in 0.01mV steps, from 1V in 1mV steps.

Current

Currents can be measured in the following basic ranges:

Basic ranges	Measurement accuracy
-4 + 21 mA	± 20 mA
0 + 45 mA	± 40 mA
-20.5 + 20.5 mA	± 40 mA

shortest span: 0.5mA

Within these basic range limits the start and end of range can be freely programmed in 0.01mA steps.

Customized linearisation

In the setup program there is a choice between linear, square law and cube law linearisation. There can be up to 41 calibration points for linear and square law linearisation, and up to 61 calibration points for cube law linearisation. These calibration points are used to determine the coefficients for polynomials defined for each section so that even a few calibration points produce a smooth graph.

Accuracy: depends on shape of graph

Action on transducer short-circuit and break

Input	Break
Thermocouple	X
Resistance thermometer	X
Resistance transmitter	-
Potentiometer	X
Voltage up to 170 mV	X
Voltage above 170mV	-
Current	X*

X = is recognised, - = is not recognised

* 0mA is recognised

In case of a break at the transducer the pens are positioned on 0%. There is no message on the 4-digit display.

12 Appendix

General data

Zero adjustment

self-compensating system using Hall sensors

Recording system

drive by stepping motor

sensitivity:

0.2 % or better referred to 100 mm recording width

reproducibility:

0.25 % or better referred to 100 mm recording width

response time:

1 sec referred to 100 mm recording width

Indication and recording accuracy

Class 0.5 referred to range limits and basic ranges

Writing system

fibre pen

Colour sequence

channel 1: blue

channel 2: red

channel 3: green

Ink capacity

sufficient for approx. 1000 m trace;
on channel 1 depending on text printing.

Pen offset

2(4) mm between pen 1 and pen 2(3).

Can be corrected by pen offset compensation.

Overrun/underrun

electronic limitation to 0 — 100 mm writing width

Chart speed

programmable from keys:

0, 5, 10, 20, 60, 120, 240, 300, 360, 600, 720, 1800, 3600, 7200 mm/h or freely programmable in 1mm/h steps

Chart drive

by stepping motor and gearbox

Chart cassette

cassette for 16 m or 32 m roll chart or 16m fanfold chart, with tear-off edge and electronic chart end switch.

Chart

roll or fanfold chart to DIN 16 230

overall width: 120 mm

writing width: 100 mm

pin spacing: 110 mm

visible chart length

roll chart: 60 mm

fanfold chart: 30 — 60 mm

overall length

roll chart: 16 m or 32 m

fanfold chart: 16 m

Scale

1, 2 or 3 scales, white, black figuring

Standard scale graduation

0 — 100 %;

for other graduations see Code sk

Supply

93 — 263 V AC 48 — 63 Hz

or

20 — 53 V DC/AC 0/48 — 63 Hz

Test voltages (type test)

to EN 61 010, Part 1 (March 1994)
overvoltage Category II,
pollution Degree 2

supply against input circuit:

on AC supply

3.7 kV 50 Hz, 1 min

on DC/AC supply

510 V 50 Hz, 1 min

supply against case

(protective earth):

on AC supply

2.3 kV 50 Hz, 1 min

on DC/AC supply

510 V 50 Hz, 1 min

12 Appendix

input against inputs and inputs against case:
510 V 50 Hz, 1 min

isolation between analogue inputs up to
30 V AC / 50 V DC

Supply voltage error

less than 0.1 % of range span

Power consumption

35 VA max.

Data back-up

by lithium battery in RAM, more than 4 years;
by storage capacitor 2 days at 15 — 25 °C
ambient temperature.

Additional back-up in EEPROM.

Electrical connection

at the back through screw-clamp connectors, max. conductor cross-section 2.5 mm²
or 2 x 1.5 mm², with core sleeves.

Setup connector at the right on the front
above the channels.

Permitted ambient temperature range

-10 to +50 °C

Ambient temperature drift

0.3 % per 10 °C

Permitted storage temperature range

-20 to +70 °C

Climatic conditions

rel. humidity 75 % max., no condensation

Operating position

NL 90 ± 30 to DIN 16 257 (vertical)

Protection

to EN 60 529 Category 2

- front IP54
- front IP65 (with extra code IP65,
without extra code ts)
- rear IP20

Electromagnetic compatibility (EMC)

EN 61 326

Interference emission:

Class B

Immunity to interference:

industrial requirements

Electrical safety

to EN 61 010

Approvals/marks of conformity

Mark of conformity:

c UL us

Testing laboratory:

Underwriters Laboratories

Certificates / certification numbers:

E 201387

Test basis:

UL 3111-1

CAN/CSA C22.2 No. 1010.1-92

valid for:

the flush-mounted instrument;

not in conjunction with any housing extra
code

12 Appendix

12.2 Error messages

All error messages are flashing on the 4-digit display at regular intervals.

The other instrument functions remain unaffected as far as possible.

Display	Cause / Remedy
Status message	
Er 13	The chart cassette has been removed or the end of the chart has been reached; a fresh chart has to be fitted. ⇒ Section 9.2 ff
Error or fault on recorder	
Er 10	The battery for the real time clock and for RAM back-up is discharged. Please contact the nearest office or the factory.
Er 14	This error message is produced when the storage capacitor (Code c, ⇒ Section 2.2) is discharged too far during supply failure. Event, supply failure and operating hour counters and the system clock are reset. The time must be set. ⇒ Section 8.9
Er 15	The communication with the external relay module ER8 is faulty. Check the connection between the recorder and the external relay module ER8.

12 Appendix

Display	Cause / Remedy
Errors on parameter input	
Err	<ul style="list-style-type: none">- Chart speed outside 0—7200 mm/h. The input has to be repeated. Input a value within the range of values.- Date is invalid. An invalid date has been input. The input has to be repeated.- Time is invalid. An invalid time has been input. The input has to be repeated.- Error in value input. The input is outside the range of values. The input has to be repeated.

12 Appendix

12.3 Hardware fault

In case of one of the following faults the recording is aborted and the error message flashes on the display.

The relays are operated as for probe break¹.
The recorder does not react to any event and can not be operated.
Please contact the nearest office or the factory.

Display	Cause / Remedy
E-12	The EEPROM in the recorder is faulty, the configuration data can no longer be stored.
E-17	The A/D converter of the recorder is faulty.
E-18	One of the Hall sensors in the recorder is faulty.

¹ The action on probe break is configured using the setup program.

12 Appendix

12.4 Status messages

The following status messages are indicated on the 4-digit display:

Display	Description
<i>in It</i>	The recorder is being initialised. Please wait.
<i>StOP</i>	The recorder is in the Stop status because key  has been pressed.
<i>StoP</i>	The recorder is in the Stop status because external stop has been activated by closing the appropriate logic input.
<i>SEt</i>	The setup connector has been plugged into the recorder. The recorder is ready for communication with the PC connected to it.
<i>bUSy</i>	The configuration data are being written to EEPROM. During this time the recorder does not respond to any inputs.

12 Appendix

12.5 Character set

032		079	O	0126	~	0212	Ô
033	!	080	P	0161	ı	0213	Õ
034	"	081	Q	0162	ç	0214	Ö
035	#	082	R	0163	£	0215	×
036	\$	083	S	0164	¤	0216	Ø
037	%	084	T	0165	¥	0217	Ù
038	&	085	U	0166	ı	0218	Ú
039	'	086	V	0167	§	0219	Û
040	(087	W	0168	¨	0220	Ü
041)	088	X	0170	ª	0221	Ý
042	*	089	Y	0171	«	0222	Þ
043	+	090	Z	0172	¬	0223	ß
044	,	091	[0173	-	0224	à
045	-	092	\	0175	-	0225	á
046	.	093]	0176	°	0226	â
047	/	094	^	0177	±	0227	ã
048	0	095	_	0178	²	0228	ä
049	1	096	`	0179	³	0229	å
050	2	097	a	0180	´	0230	æ
051	3	098	b	0181	µ	0231	ç
052	4	099	c	0182	¶	0232	è
053	5	0100	d	0183	·	0233	é
054	6	0101	e	0184	¸	0234	ê
055	7	0102	f	0185	¹	0235	ë
056	8	0103	g	0186	º	0236	ì
057	9	0104	h	0187	»	0237	í
058	:	0105	i	0191	¸	0238	î
059	;	0106	j	0192	À	0239	ï
060	<	0107	k	0193	Á	0240	ð
061	=	0108	l	0194	Â	0241	ñ
062	>	0109	m	0195	Ã	0242	ò
063	?	0110	n	0196	Ä	0243	ó
064	@	0111	o	0197	Å	0244	ô
065	A	0112	p	0198	Æ	0245	õ
066	B	0113	q	0199	Ç	0246	ö
067	C	0114	r	0200	È	0247	÷
068	D	0115	s	0201	É	0248	ø
069	E	0116	t	0202	Ê	0249	ù
070	F	0117	u	0203	Ë	0250	ú
071	G	0118	v	0204	Ì	0251	û
072	H	0119	w	0205	Í	0252	ü
073	I	0120	x	0206	Î	0253	ý
074	J	0121	y	0207	Ï	0254	þ
075	K	0122	z	0208	Ð	0255	ÿ
076	L	0123	{	0209	Ñ		
077	M	0124		0210	Ò		
078	N	0125	}	0211	Ó		

12.6 Summary of the parameters

Parameter	Description	Programming
Instr. designation	Designation of recorder	S S = via setup R = on recorder
Language	Language (for print-outs)	R, S
Summer time	Start and end of summer time	R, S
Display time	Switch on/off display of time in the basic status	R, S
Inputs	Selection of analogue input signals	S
Writing status	Writing status ON/OFF for each channel	S
Scaling	Scaling of measurements for recording	S
Unit	Unit of recorded measurements	S
Number format	Selection of decimal places in alpha-numerical presentation	S
Channel designation	Designation of the channel	S
Plotarea (zoom)	Magnifier function, input in %	S
Offset (presentation range)	Restriction of recording width, input in mm	S
Chart speed	Chart speed in mm/h	S
Limit operation	Chart speed on overlimit/underlimit	S
Timed operation	Chart speed within a specified time period	S
Pen offset compensation	Compensation of offset between the pens	S
Scale printing	Spacing of the cyclic scaling print-out in cm	S
Time printing	Spacing of the cyclic time print-out in cm	S
Text at recording start	Text printed at start of recording	S
Text at recording end	Text printed at end of recording	S

12 Appendix

Parameter	Description	Programming
Report	Setting the period of the statistical report	S = via setup R = on recorder
Printing priorities	Priorities in printing text	S
Printing mode	Trace interrupted or overwritten when printing text	S
Code	Codenummer for level inhibit	S
Relay outputs		
- relay function	Function of the limit relays	S
- relay limit	Limit at which the particular relay switches (differential only via setup program)	R, S
- relay text	Text reporting the switching of the relay	S
Logic inputs		
- external text	Text printed when signal is applied to logic input	S
- binary-linked external text	Texts printed when certain binary signals are applied to the first four logic inputs	S
- external stop	A definable logic input stops the recording when a signal is applied	S
- external speed	A definable logic input switches over to a certain chart speed	S
- event counter	Level changes at a logic input can be counted and reported	S
- external scale printing	Printing the scaling of all activated channels can be initiated from a logic input	S
- external report	Producing a statistical report via a logic input	S

Index

A

accessories *12*
analogue inputs *16*

B

basic status *22, 44*

C

channel label *18*
character set *82*
chart cassette
 changing fanfold chart *62*
 changing roll chart *61*
 converting *63*
 removing and fitting cassette *59*
chart fast forward *44*
chart speed *46*
clock time *32*
codenumber *23, 49, 84*
Codes, extra *11*
connection diagram *16*
consumables *58*
cut-out, panel *14*

D

date and time *52*
decimal place *26*
description of instrument *9*
differential of limit *55, 65*
display and controls *18*
display time *57*
documentation *6*
door *18*

E

earth line, protective *15*
electrical connection *16*

electromagnetic compatibility (EMC) *77*
electrostatic discharge (ESD) *5*
entering parameters *25*
error messages *25, 78*
event counter *40*
external report *41*
extra Codes see Codes *11*

F

fanfold chart *58*
fibre pen *58*
fitting fibre pen *19*
fitting in position *14*
front view *14*

H

hardware error *80*
hazardous area (EX) *15*

I

installation notes *15*
interface description *6*

L

language *51*
LED display *18*
level inhibit and codenumber request *49*
levels *22*
 basic status *22*
 operating level *22*
 parameter level *23*
limit *55, 65*
 differential of *55, 65*
limit comparator
 lk7 *67*
 lk8 *67*
limit mark *33*
location of recorder *13*

Index

logic inputs 64

M

maths and logics module 70

O

online help 6

operating level 22, 45

Operating Manual 5

operating mode

 basic status 20, 22

 external chart speed 20

 limit operation 20

 normal chart speed 20

 timed operation 20

operation 22

ordering example 12

outputs, switching 65

P

panel cut-out see cut-out 14

parameter coding 24

parameter level 23, 50

parameter summary 83

parameter, entering see entering 25

plotarea (zoom) 21

print test 42, 47

printing mode 30

printing priority 27

probe break 80

programming

 abort 25

 chart speed 46

 date and time 52

 language 51

 level inhibit and code request 49

 print test 47

 relay limits 55

 selection 26

 service print 48

 summer time 53

 value input 26

R

recording

 pen offset compensation 21

 plotarea (zoom) 21

 presentation range (offset) 21

 scaling 21, 33

 start and end text 37

rectification of faults 72

reference time 52

relay limits 55

relay module ER8, external 64

report, statistical 41

returning the recorder 5

roll chart 58

RS 422/RS 485 10

RS232 68

RS422 / RS485 6, 17, 71

S

selection 26

service print 43, 48

setup program 6, 68

side view 14

starting up 5

status

 external stop 20

 stop 20

status messages 81

sub-parameters 24

summary of parameters 83

summer time 53

switching outputs see outputs 65

system clock 52, 53

Index

T

technical data 74
text printing 27
 abort criteria 27
 chart speed 35
 clock time 32
 cyclic scale printing 33
 event counter 40
 external report 41
 external text, binary-linked text, relay texts 38
 fixed priorities 29
 interrupting trace 30
 limit mark 33
 overwriting trace 31
 presentation range (offset) 33
 print test 42
 printing mode 30
 printing priority 27
 recording start and end 37
 relay texts 39
 scaling 33
 scaling, triggered 34
 service print 43
 statistical report 41
text printing request, latest 28
timed operation 20
trace
 interrupting 30
 overwriting 31
tree structure 24
type designation 10
typographical conventions 7

U

UL approval 11, 77

V

value input 26

W

warranty 5



JUMO GmbH & Co. KG

Street address:
Moritz-Juchheim-Straße 1
36039 Fulda, Germany
Delivery address:
Mackenrodtstraße 14
36039 Fulda, Germany
Postal address:
36035 Fulda, Germany
Phone: +49 661 6003-0
Fax: +49 661 6003-607
e-mail: mail@jumo.net
Internet: www.jumo.net

JUMO Instrument Co. Ltd.

JUMO House
Temple Bank, Riverway
Harlow, Essex CM20 2DY, UK
Phone: +44 1279 635533
Fax: +44 1279 635262
e-mail: sales@jumo.co.uk
Internet: www.jumo.co.uk

JUMO Process Control, Inc.

8 Technology Boulevard
Canastota, NY 13032, USA
Phone: 315-697-JUMO
1-800-554-JUMO
Fax: 315-697-5867
e-mail: info@jumo.us
Internet: www.jumo.us