

JUMO DICON 401/501

Universal Profile Controller

Universal Profile Generator



Type 703585/2...



Type 703585/1...



Type 703580/0...

B 703580

Operating Manual





Please read this operating manual before commissioning the instrument. Keep the manual in a place which is accessible to all users at all times.

Your comments are appreciated and may help us in improving this manual.

All necessary settings are described in this operating manual. Manipulations not described in the manual or expressly forbidden will jeopardize your warranty rights. Please contact the nearest subsidiary or the head office, should you encounter problems.



When accessing the inner parts of the unit and returning modules, assemblies or components, please observe the regulations according to EN 61340-5-1 and EN 61340-5-2 „Protection of electrostatic sensitive devices“. Only use **ESD** packaging for transport.

Please note that we cannot accept any liability for damage caused by ESD.

ESD=Electro Static Discharge

Contents

1	Introduction	7
1.1	Description	7
1.2	Block structure	7
1.3	Typographical conventions	8
1.3.1	Warning signs	8
1.3.2	Note signs	8
1.3.3	Presentation	8
2	Identifying the instrument version	9
2.1	Type designation	9
2.2	Accessories	10
3	Installation	11
3.1	Location and climatic conditions	11
3.2	Dimensions	11
3.2.1	Type 703580/0...	11
3.2.2	Type 703585/1...	12
3.2.3	Type 703585/2...	12
3.3	Edge-to-edge mounting	13
3.4	Fitting into position	13
3.5	Cleaning the front panel	13
3.6	Removing the controller chassis	14
4	Electrical connection	15
4.1	Installation notes	15
4.2	Connection diagrams	16
4.2.1	Type 703580	16
4.2.2	Type 703585 (portrait and landscape format)	19
4.3	Isolation	21

5	Operation	23
5.1	Displays and keys	23
5.2	Operating modes and states	24
5.3	Principle of operation	25
5.4	Entering values and selecting settings	26
5.5	Operating modes	27
5.5.1	Basic status	27
5.5.2	Manual operating mode	28
5.5.3	Automatic operating mode (program run)	29
5.6	Shifting the setpoint	30
5.7	Altering setpoints	30
5.8	Setpoint switching	31
5.9	Display switching	32
6	Profile program start	33
6.1	Instant start of program	33
6.2	Delayed start of program	33
7	Profile program editor	35
7.1	General	35
7.2	Editing segments	37
7.3	Inserting segments	38
7.4	Copying segments	38
7.5	Deleting segments	39
7.6	Programming repeat cycles	39
7.7	Temporary alterations	40

8	Operating level	41
9	Parameter level	43
10	Configuration level 1	45
10.1	Controller	47
10.2	Limit comparators	49
10.3	Inputs	52
10.4	Outputs	57
10.5	Profile controller	59
10.6	Maths and logic module	62
10.7	Display	67
10.8	Logic functions	70
10.9	Interface	73
11	Optimisation	75
11.1	Self-optimisation	75
11.2	Checking the optimisation	76
11.3	Fuzzy parameters	77
12	Retrofitting of cards	79
13	Interfaces	83
13.1	RS422/485 interfaces	83
13.2	PROFIBUS-DP	84
14	Accessories	85
14.1	External relay module/logic module ER8/EL8	85
14.2	Setup program with commissioning software	86

Contents

15	Appendix	87
15.1	Technical data	87
15.2	Alarm messages and display priorities	90
15.3	Character set for matrix display	93
15.4	Instrument features (configuration level 2)	94
15.5	Notes for instruments with Germanischer Lloyd (GL) approval	95
15.5.1	Technical data	95
15.5.2	Alarm messages	95
15.5.3	Inhibits	95
15.5.4	Manual mode	95
15.5.5	Additional notes	95
16	Index	97

1.1 Description

This series of universal, freely configurable profile controllers/profile generators is available in the formats 96mm x 96mm and 96mm x 48mm (portrait and landscape format). The instruments feature two 4-digit 7-segment displays, five or eight LEDs for indicating the switching status and the operating modes, an 8-digit matrix display, as well as six keys for operation and configuration.

The user has flexibility in assigning the instrument slots, in accordance with the block structure.

10 profile programs with up to 100 segments can be programmed; a total of 100 segments can be implemented.

Additional functions include self-optimisation, parameter set switching, a real-time clock, up to eight limit comparators and a maximum of eight operating contacts. Linearisation for the usual transducers are stored in the memory, and a customized linearisation table can be programmed. The instruments can be adapted to the most diverse tasks with the aid of a maths module. The instruments can be integrated into a data network via a serial interface, or they can be expanded through an external relay module. A setup program with a program editor is available for easy configuration from a PC.

The electrical connection is at the rear by screw terminals.

1.2 Block structure

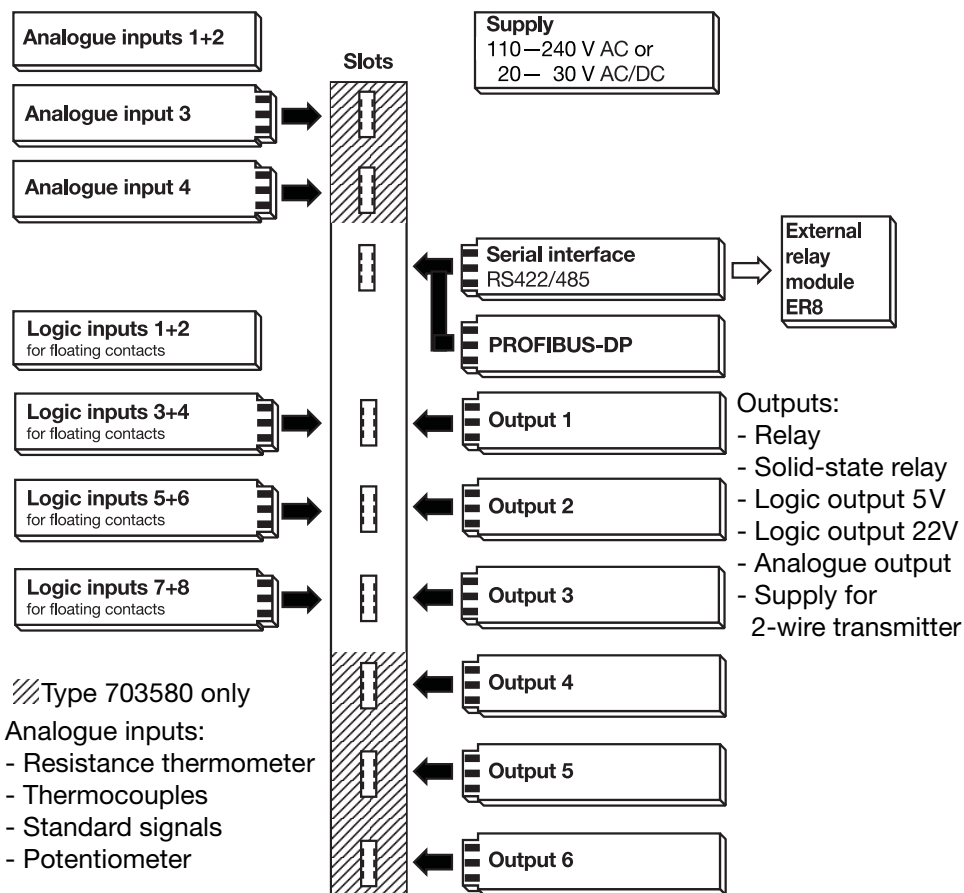

1 Introduction

1.3 Typographical conventions

1.3.1 Warning signs



Danger

The signs for **Danger** and **Warning** are used in this manual under the following conditions:

This sign is used when there may be **danger to personnel** if the instructions are disregarded or not followed accurately.



Warning

This sign is used when there may be **damage to equipment or data** if the instructions are disregarded or not followed accurately.



Warning

This sign is used when special care must be taken when handling components that are sensitive to electrostatic discharges.

1.3.2 Note signs



Note

This symbol is used when your attention is drawn to a **specific remark**.



Reference

This sign refers to additional information in other manuals, chapters or sections.

*** Action**

This sign refers to an action to be performed. The individual steps are marked by this asterisk, e. g.:

* Press  key

1.3.3 Presentation



Key combination

The depiction of keys together with a plus sign means that first the **ENTER** key has to be pressed and held down, and then a further key is pressed.

CONFIG 1

Dot-matrix display

Texts and messages are visualised in the dot-matrix display.

2 Identifying the instrument version

2.1 Type designation

703580/ **(1)** - **(2)** - **(3)** - **(4)** - **(5)** / **(6)** , **(7)**

Format 96 mm x 96 mm

703585/ - **0 0** - **0 0 0** - - / ,

Format 48 mm x 96 mm and 96 mm x 48 mm

(1) Basic type extension			
Format:			
96 mm x 96 mm	0		
48 mm x 96 mm portrait	1		
96 mm x 48 mm landscape	2		
Version:			
Standard with factory default settings		8	
Customized programming		9	
Language for instrument texts:			
German			1
English			2
French			3

(2) Analogue input	1	2	3	4
not assigned	0	0	0	0
Universal input (all transducers except voltage -10/2/0 – 10V)	1	1	1	1
voltage -10/2/ 0 – 10V	2	2	2	2

(3) Output	1	2	3	4	5	6
not assigned	0	0	0	0	0	0
Relay (changeover contact)	1	1	1	1	1	1
Solid-state relay 230V 1A	2	2	2	2	2	2
Logic 0/5V	3	3	3	3	3	3
Logic 0/22V	4	4	4	4	4	4
Analogue output	5	5	5	5	5	5
Supply for 2-wire transmitter	6	6	6	6	6	6
Two logic inputs	7	7	7	-	-	-

(4) Supply		
110 – 240V AC +10/-15 %		
48 – 63Hz	2	3
20 – 30V AC/DC 48 – 63Hz	2	5

(5) Interface		
not assigned	0	0
RS422/485	5	4
PROFIBUS-DP (no GL approval)	6	4

(6) Maths and logic module		
not available	0	0
available	0	3

(7) Approvals			
DIN EN 14597*	0	5	6
Germanischer Lloyd (GL)*	0	6	2
DIN EN 14597 and GL*	0	6	3
DIN EN 14597 and UL*	0	6	4
GL and UL*	0	6	5
DIN EN 14597, GL and UL*	0	6	6

* Type 703580 only

Delivery package

- Profile controller/generator
- 2 mounting brackets
- seal
- Operating Manual B 703580

2 Identifying the instrument version

2.2 Accessories

External relay module ER8 (3A/230V) Supply 110 — 240V AC Part no. 00405292 (no GL approval)
External relay module ER8 (3A/230V) Supply 20 — 53V DC/AC Part no. 00405297 (no GL approval)
External logic module EL8 (0/12V) Supply 110 — 240V AC Part no. 00439131 (no GL approval)
External logic module EL8 (0/12V) Supply 20 — 53V DC/AC Part no. 00471459 (no GL approval)
PC interface for setup program with USB/TTL converter, 2 adapters (socket, pins) Part no. 00456352
Setup program and program editor for Windows® NT4.0/2000/XP/Vista/7 (32/64 bit) Part no. setup program: 00379085 Part no. program editor: 00379547 Hardware requirements: - 512 Mbyte RAM - 50 Mbyte available on hard disk - CD-ROM drive - 1 free serial interface or USB interface

3.1 Location and climatic conditions

The conditions at the instrument location must conform to the requirements listed under Technical data. The ambient temperature at the location should be between -5 and 55 °C, at a relative humidity of not more than 95 %.

3.2 Dimensions

3.2.1 Type 703580/0...

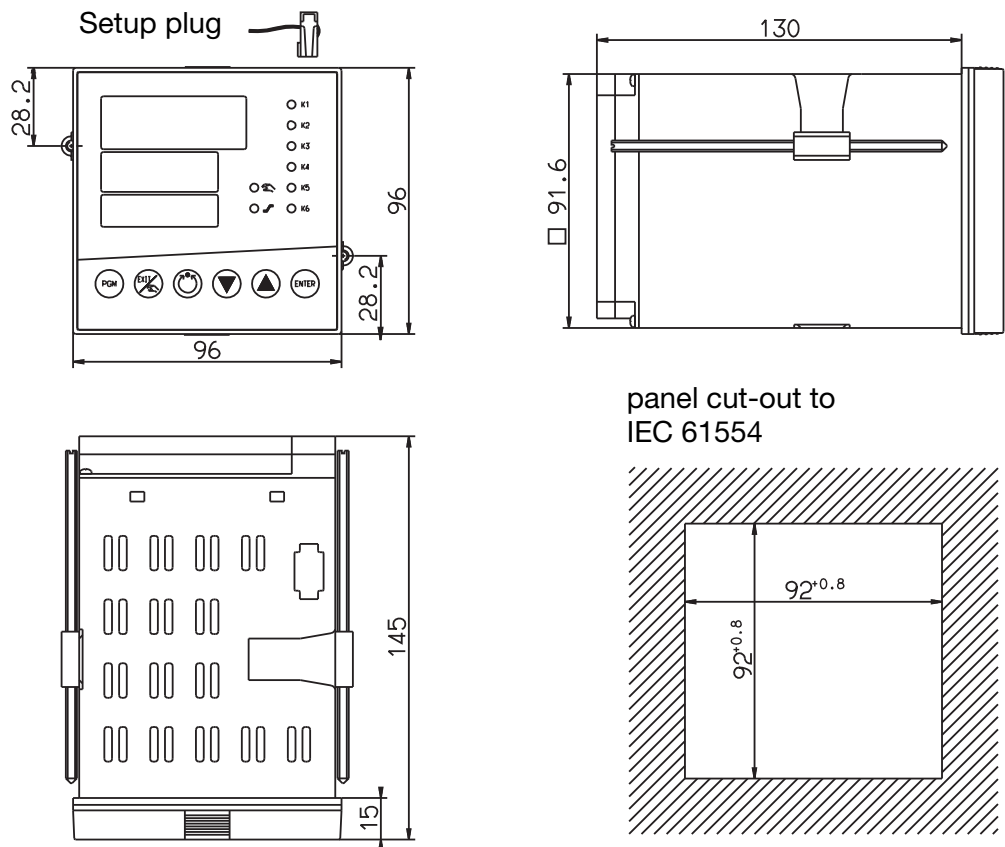

3 Installation

3.2.2 Type 703585/1...

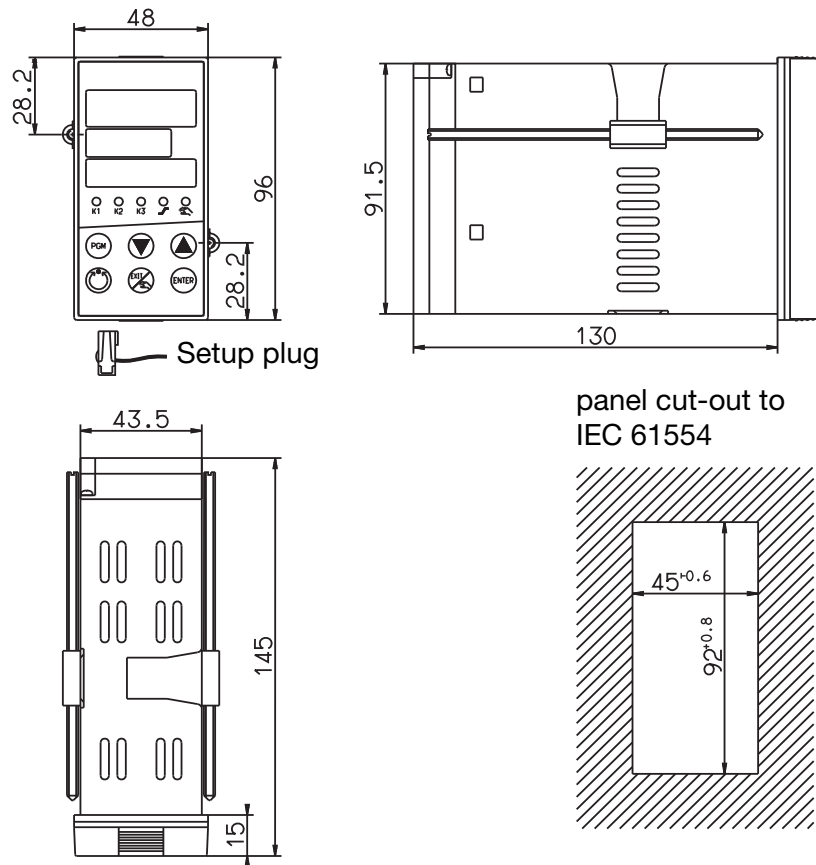

3.2.3 Type 703585/2...

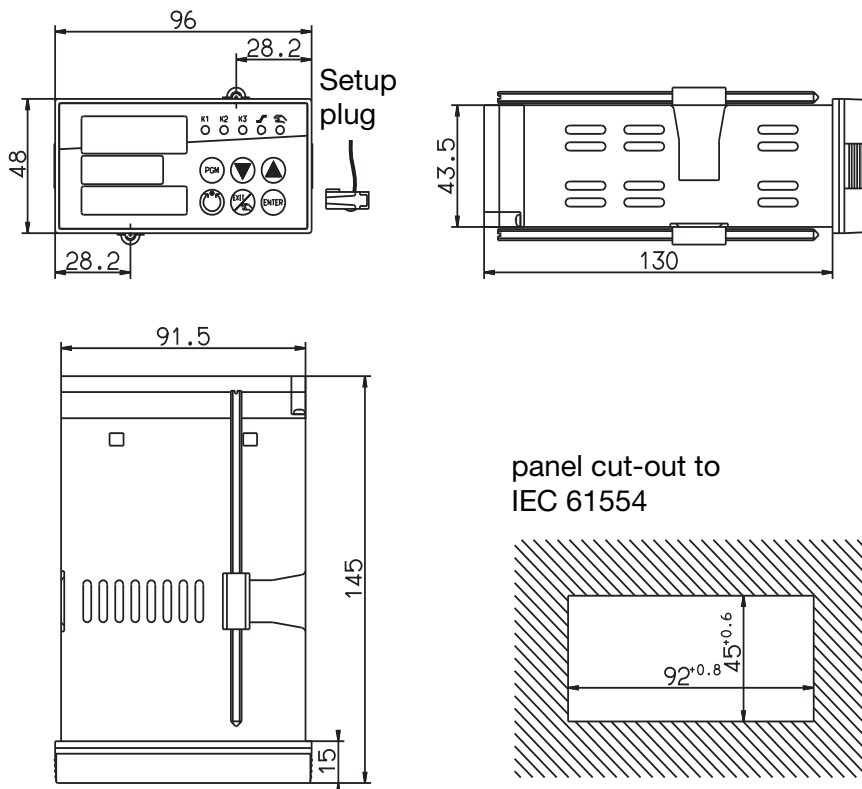

3.3 Edge-to-edge mounting

Type	Minimum spacing of the panel cut-outs	
	horizontal	vertical
without setup plug:		
703580/0...	11 mm	30 mm
703585/1... (portrait format)	11 mm	30 mm
703585/2... (landscape format)	30 mm	11 mm
with setup plug:		
703580/0...	11 mm	65 mm
703585/1... (portrait format)	11 mm	65 mm
703585/2... (landscape format)	65 mm	11 mm

3.4 Fitting into position

- * Fit the seal provided onto the instrument body.
- * Insert the controller from the front into the panel cut-out.
- * Insert the mounting brackets from the rear of the panel into the guides at the sides of the housing. The flat sides of the brackets must be against the housing.
- * Place the brackets against the rear of the panel and tighten them evenly with a screwdriver.

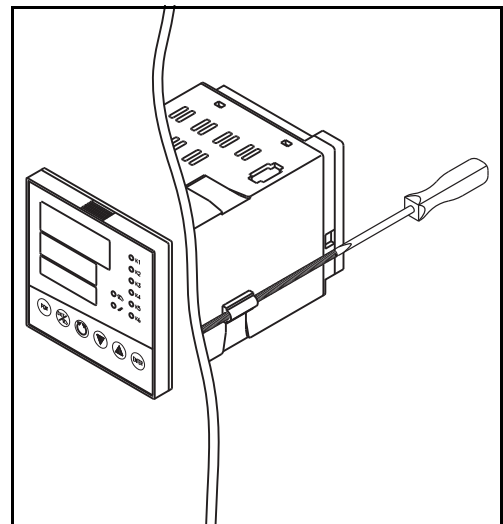

3.5 Cleaning the front panel

The front panel can be cleaned with the usual rinsing and cleaning agents. It has a limited resistance to organic solvents (e. g. methylated spirits, white spirit, P1, xylol, etc.). Do not use high-pressure cleaning equipment.

3 Installation

3.6 Removing the controller chassis

The controller chassis can be removed from the housing for servicing.

- * Press together the ribbed surfaces top and bottom (or left and right with the landscape format) and pull out the controller chassis.

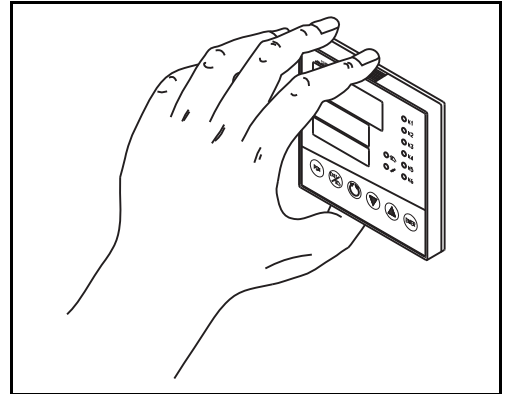

When inserting the controller chassis, care must be taken that the lugs (underneath the ribbed surfaces) snap into position.

4.1 Installation notes

- The choice of cable, the installation and the electrical connection of the instrument must meet the requirements of VDE 0100 “Regulations on the installation of power circuits with nominal voltages below 1000 V” or the appropriate local regulations.
- The electrical connection must only be carried out by qualified personnel.
- The instrument shall be operated by mains protected with a branch circuitry overcurrent protection device not more than 20 Amps.
For servicing/repairing a Disconnecting Device shall be provided to disconnect all conductors.
- A current-limiting resistor interrupts the supply circuit in the event of a short circuit. The load circuit must be fused for the maximum relay current to prevent welding of the output relay contacts in the event of a short circuit.
- Electromagnetic compatibility conforms to the standards and regulations specified under Technical Data.
- Input, output and supply lines should be run separately, not parallel to one another.
- All input and output cables without connection to the mains supply must be arranged as twisted and screened cables. Earth the screen at one end at the instrument terminal TE.
- Earth the instrument at terminal TE to the earth conductor. This line must have at least the same cross-section as the supply lines. Earth lines should be run in a star layout to a common earth point which is connected to the earth conductor of the supply. Do not loop the earth connections, i. e. do not run them from one instrument to another.
- Do not connect any additional loads to the supply terminals of the instrument.
- The instrument is not suitable for installation in hazardous areas.
- Apart from faulty installation, there is a possibility of interference or damage of controlled processes due to incorrect settings on the controller (setpoint, data of parameter and configuration levels, internal adjustments). Safety devices independent of the controller, such as overpressure valves or temperature limiters/monitors, should always be provided and should be capable of adjustment only by specialist personnel. Please refer to the appropriate safety regulations in this connection. Since adaptation (self-optimisation) cannot be expected to handle all possible control loops, there is a theoretical possibility of unstable parameter settings. The resulting process value should therefore be monitored for its stability.
- The maximum permitted voltage difference between the inputs of the controller and TE is 30 V AC or 50 V DC.

4 Electrical connection

4.2 Connection diagrams

4.2.1 Type 703580

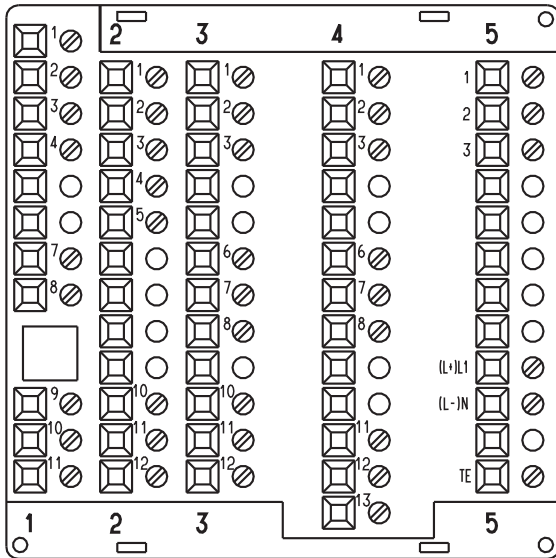

The electrical connection must only be made by suitably qualified personnel



The instrument version can be identified by the type code.



PROFIBUS-DP:

⇒ Interface Description B 703560.2.3

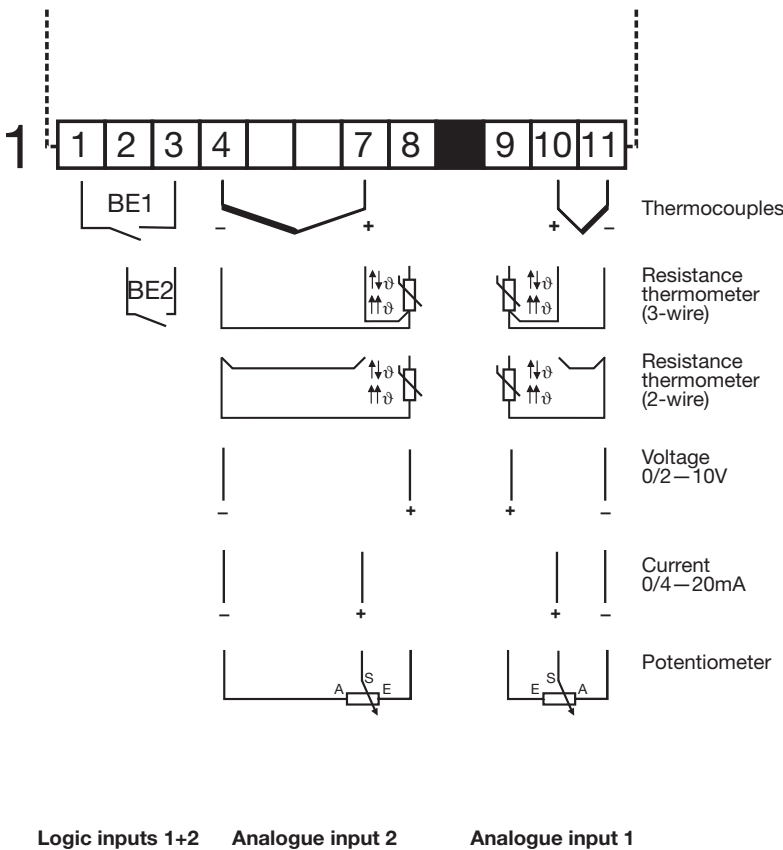

When a thermocouple with internal temperature compensation is wired up to the analogue inputs 1, 3 or 4, no Pt500, Pt1000 or KTY must be connected to analogue input 2.

4 Electrical connection

Type 703580

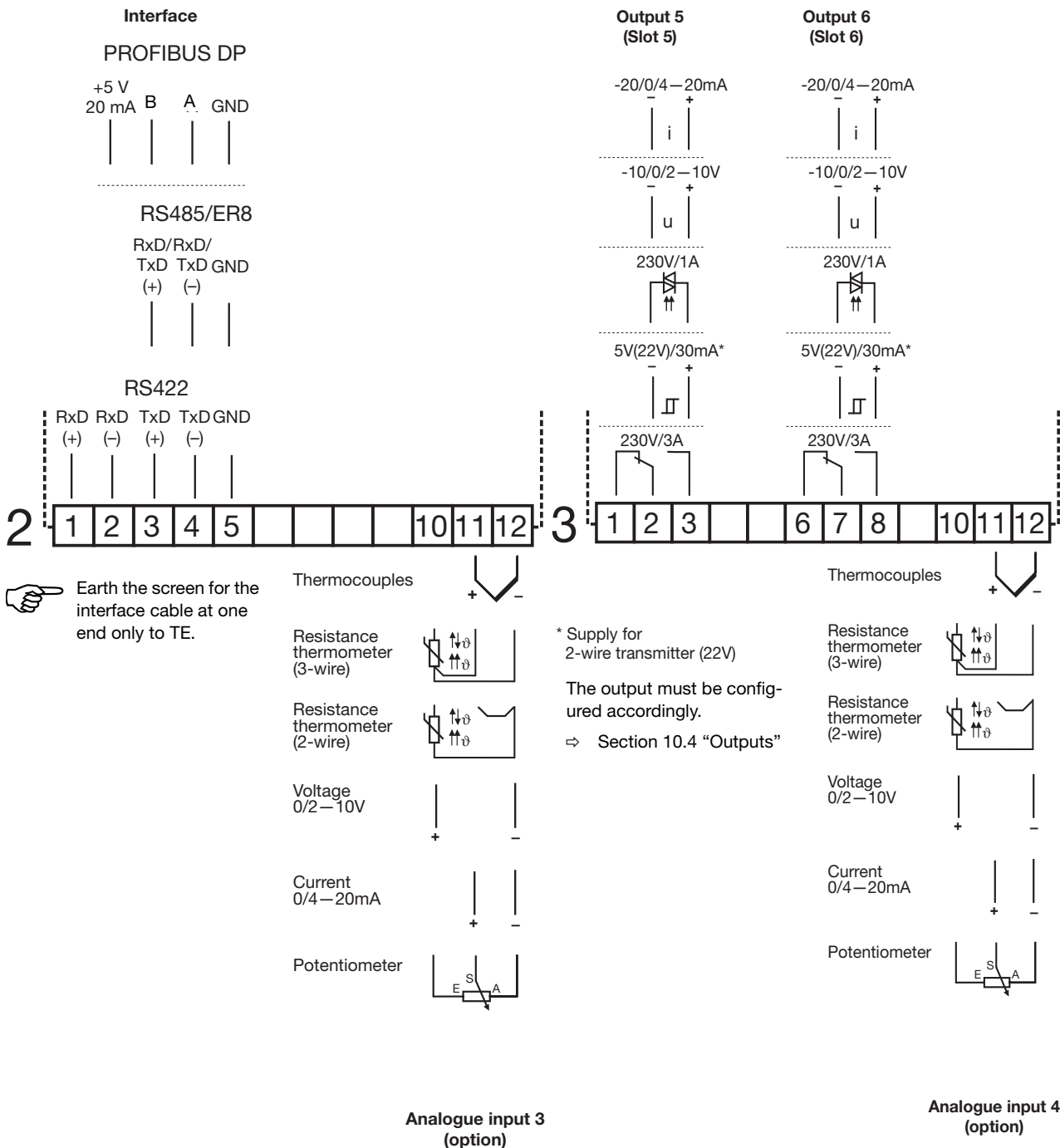

⇒ Section 12 "Retrofitting of cards"

Additional analogue input signals	
Signal	Connection like
0 - 1V	0 - 10V
-1 to +1V	0 - 10V
-10 to +10V	0 - 10V
0 - 100mV	thermocouple
-100 to +100mV	thermocouple

Contact protection circuit for the relay outputs:
56Ω/15nF between common-make/common-break

4 Electrical connection

Type 703580

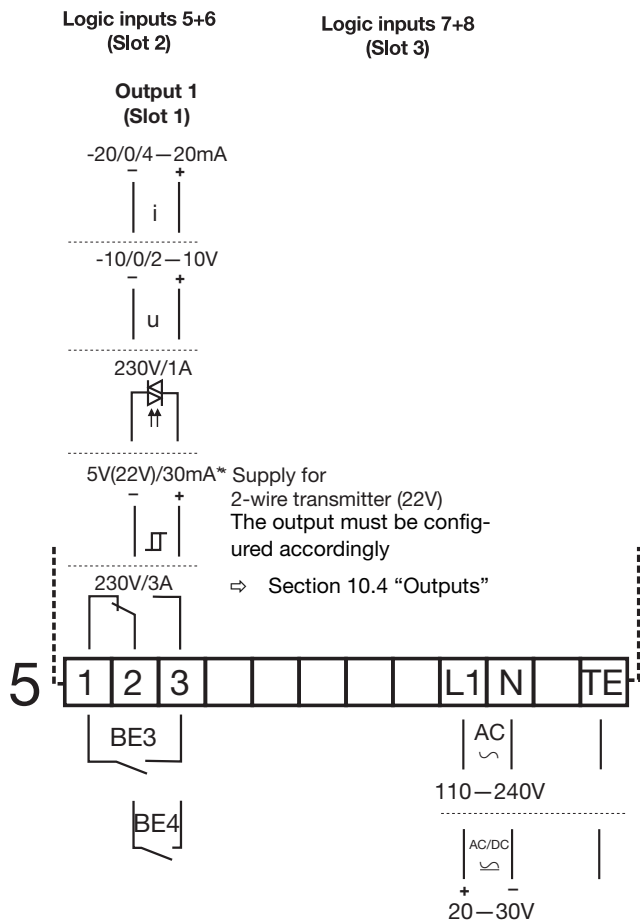
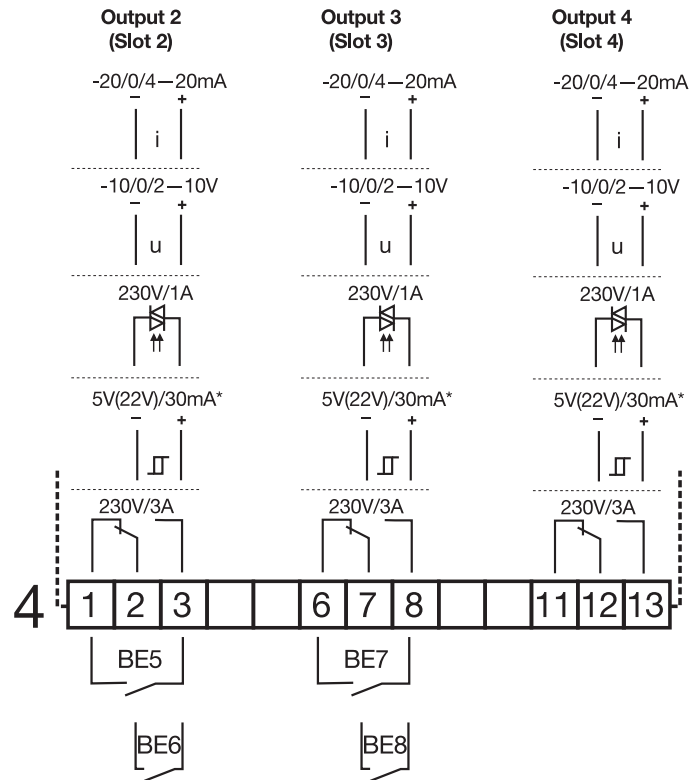

Contact protection circuit for the relay outputs:
 56Ω/15nF between common-make/common-break

Logic inputs 3+4 (Slot 1)

Mains supply

4 Electrical connection

4.2.2 Type 703585 (portrait and landscape format)

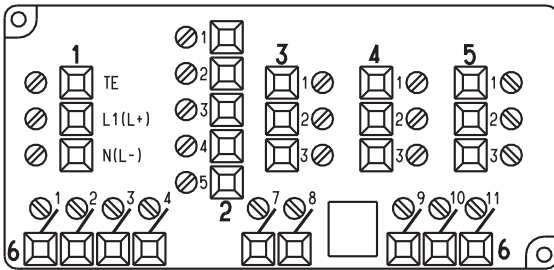

The electrical connection must only be made by suitably qualified personnel.



The instrument version can be identified by the type code.

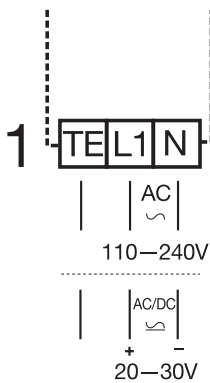
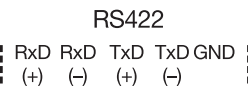
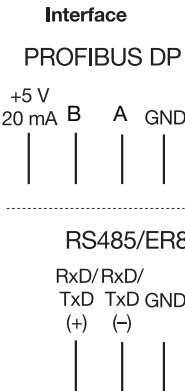

Mains supply

2

Earth the screen for the interface cable at one end only to TE.

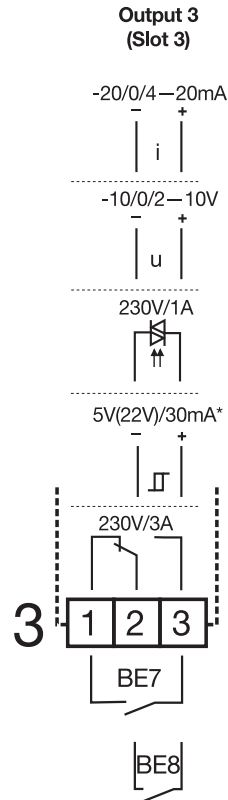

Logic inputs 7+8 (Slot 3)

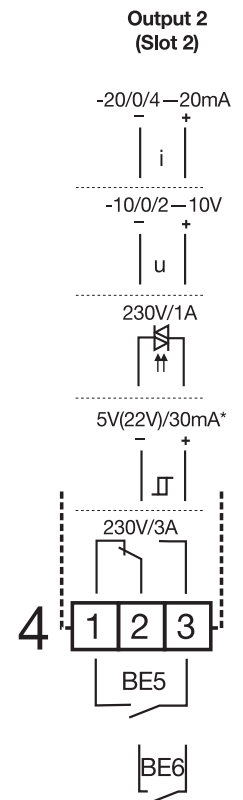

Logic inputs 5+6 (Slot 2)



PROFIBUS-DP:

⇒ Interface Description B 703560.2.3

* Supply for 2-wire transmitter

The output must be configured accordingly.

⇒ Section 10.4 "Outputs"

Contact protection circuit for the relay outputs:
56Ω/15nF between common-make/common-break

4 Electrical connection

Type 703585

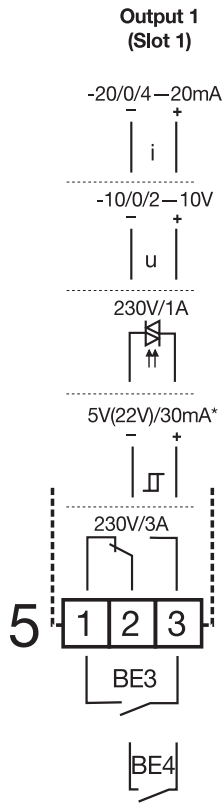

* Supply for 2-wire transmitter

The output must be configured accordingly.

⇒ Section 10.4 “Outputs”

Contact protection circuit for the relay outputs:
56Ω/15nF between common-make/common-break

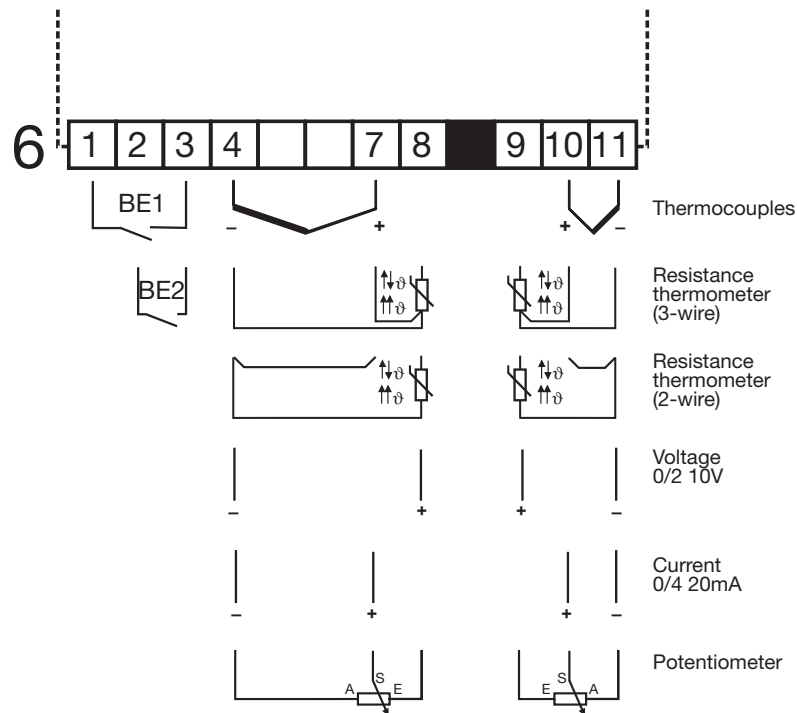

Logic inputs 3+4 (Slot 1)

Logic inputs 1+2 Analogue input 2 Analogue input 1
⇒ Section 12 “Retrofitting of cards”

Additional analogue input signals	
Signal	Connection like
0 – 1V	0 – 10V
-1 to +1V	0 – 10V
-10 to +10V	0 – 10V
0 – 100mV	thermocouple
-100 to +100mV	thermocouple

When a thermocouple with internal temperature compensation is wired up to analogue input 1, no Pt500, Pt1000 or KTY must be connected to analogue input 2.

4.3 Isolation

For Type 703580 and Type 703585

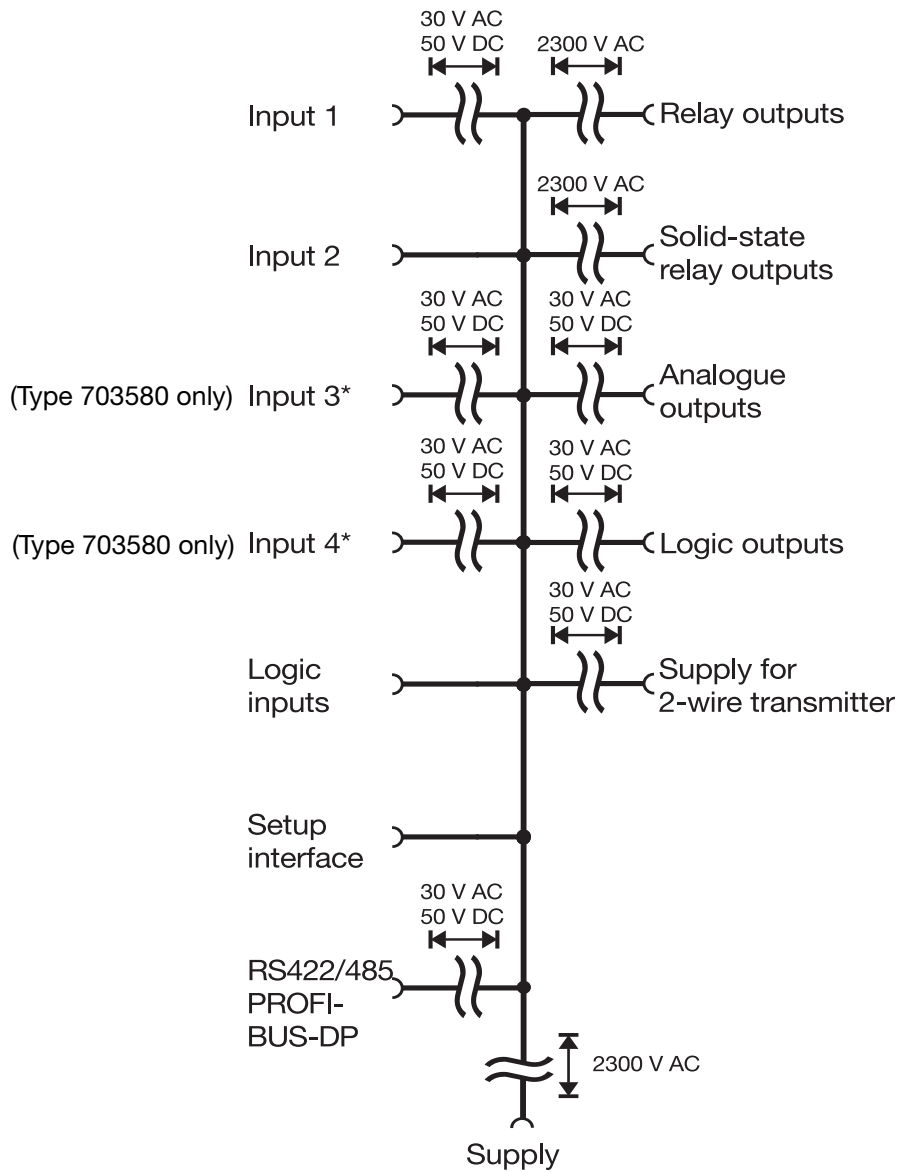

4 Electrical connection

5.1 Displays and keys

<p>(1) configurable 7-segment display (display 1)</p> <table border="1"> <thead> <tr> <th>Type</th> <th>Height</th> </tr> </thead> <tbody> <tr> <td>703580</td> <td>13mm</td> </tr> <tr> <td>703585</td> <td>10mm</td> </tr> </tbody> </table> <p>factory setting: process value</p>	Type	Height	703580	13mm	703585	10mm	<p>(4) Setup interface Position depending on model; see dimensional drawings ⇒ Section 3.2 “Dimensions”</p>
Type	Height						
703580	13mm						
703585	10mm						
<p>(2) configurable 7-segment display (display 2)</p> <table border="1"> <thead> <tr> <th>Type</th> <th>Height</th> </tr> </thead> <tbody> <tr> <td>703580</td> <td>10mm</td> </tr> <tr> <td>703585</td> <td>7mm</td> </tr> </tbody> </table> <p>factory setting: setpoint</p>	Type	Height	703580	10mm	703585	7mm	<p>(5) Status indicators 6 (3) yellow LEDs for the status indication of the outputs¹ 2 green LEDs to display the operating modes “Manual” and “Automatic”</p>
Type	Height						
703580	10mm						
703585	7mm						
<p>(3) configurable dot-matrix display (display 3) 8-digit, green factory setting: profile program/segment number</p>	<p>(6) Keys (see below)</p>						

1. no display for analogue outputs.

⇒ Section 10.7 “Display”









Key designation

Keys from left to right:
 PGM for programming
 Exit/Hand for programming and for manual mode¹
 Automatic to start programs
 Decrement to decrease parameter values
 Increment to increase parameter values
 Enter for programming and display switching

1. In the description below the key is shown according to its function (**EXIT** or).

5 Operation

5.2 Operating modes and states

Operating mode/state	Display	Notes
Basic status	 	<p>The displays represent the values according to the display configuration. ⇒ Section 10.7 “Display”</p> <p>factory setting:- process value - setpoint of basic status - text BASIC ST</p> <p>The active parameter set is indicated by an additional decimal point. ⇒ Chapter 9 “Parameter level”</p>
Automatic		<p>Profile program is running. ⇒ Chapter 6 “Profile program start”</p>
Manual		<p>Process variables (e. g. operating contacts) are being modified by hand. ⇒ Section 5.5.2 “Manual operating mode”</p>
Program stop		<p>Current profile program is stopped. ⇒ Section “Holding the profile program”</p>
Standstill		<p>Condition after supply failure when configured accordingly. ⇒ Section 10.5 “Profile controller”</p> <p>* Continue profile program with </p> <p>or</p> <p>* cancel profile program with ENTER</p>
Self-optimisation		<p>Self-optimisation is running. ⇒ Section 11.1 “Self-optimisation”</p>
Alarm messages	-	⇒ Section 15.2 “Alarm messages and display priorities”

○ - LED is off; ● - LED is on

5.3 Principle of operation

Basic status	Initial status.
Profile program start	Profile programs are selected here, and the instant of start as well as the start conditions are defined.
Profile program editor	Profile programs are created here.
Operating level	This level is available for programming setpoints, displaying process variables, altering system states and setting the time.
Parameter level	The profile controller is adapted to the control loop with the aid of the parameters in this level.
Configuration level 1	This level is available for adapting the profile controller to the control task.
Configuration level 2	The software version and the hardware specifications of the profile controller are indicated here.
Service	Only accessible to service personnel.
Time-out	If no key is pressed during a configurable period (factory-set: 30sec), then the profile controller will automatically return to basic status.
Code request	In order to access some levels, a code has to be entered first. The codes can be altered via the setup program.

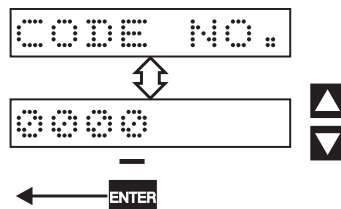

Codes are entered digit by digit.

- * Enter the digit with ▲ and ▼
- * Step on to the next digit with ENTER

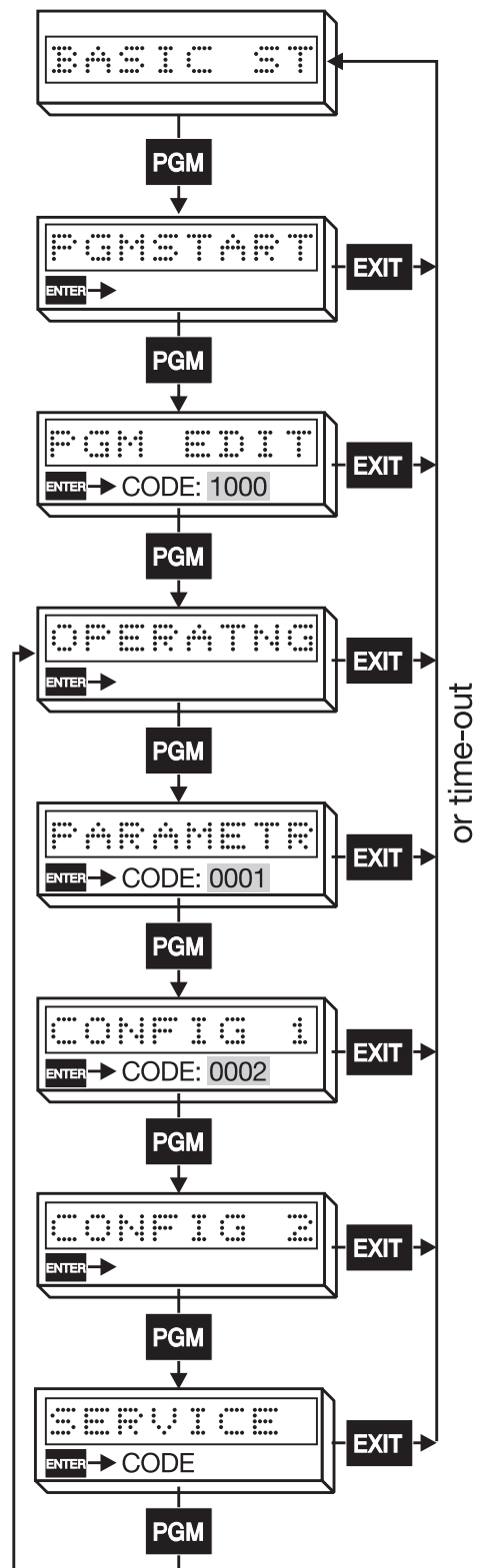

■ = factory setting

5 Operation

Levels and menus

Each level is divided into menus, thus creating a tree structure which has a selection or a value input at the end of each branch.

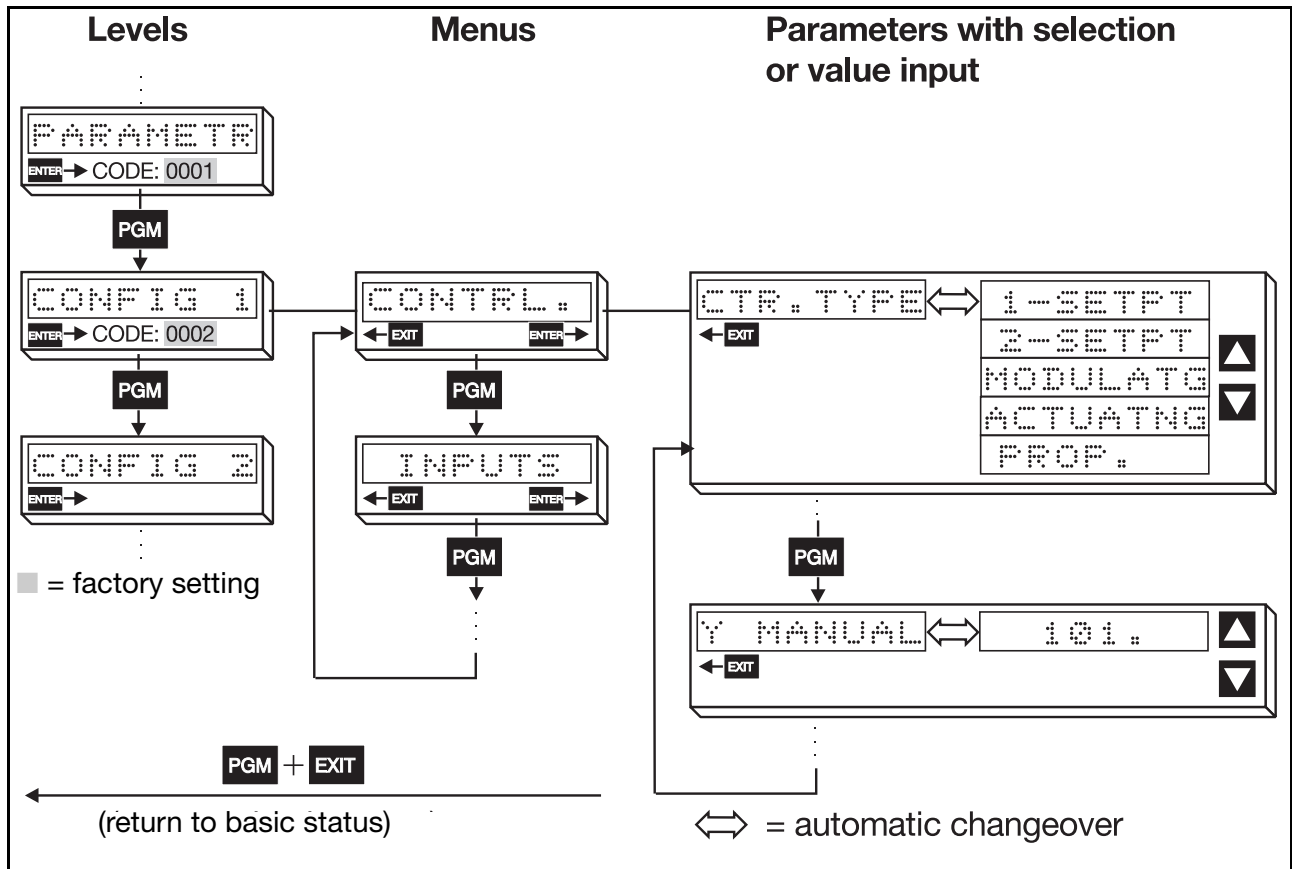

5.4 Entering values and selecting settings

Value input

- * Increase parameter value with ▲
- * Decrease parameter value with ▼

The longer the key is pressed, the more quickly the value changes. Approx. 1 sec after releasing the key, the entry is accepted automatically (display flashes briefly).

Parameters can be altered within their value range or within the maximum values that can be displayed (e. g. 2 decimal places: -99.99 to +99.99).

Shifting the decimal point

- * Increase the decimal places with ENTER + ▲
- * Decrease the decimal places with ENTER + ▼ (last digit must be 0)

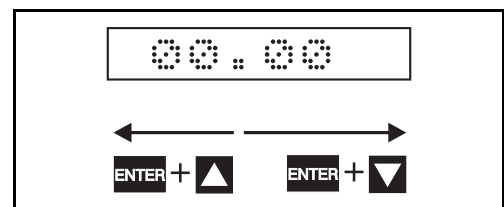

Code and time input

Time inputs and codes are entered digit by digit.

- * Increase or decrease value (digit) with ▲ and ▼
- * Confirm entry and select next digit with ENTER

All digits must be confirmed with ENTER. The value is accepted automatically when the last digit is entered.

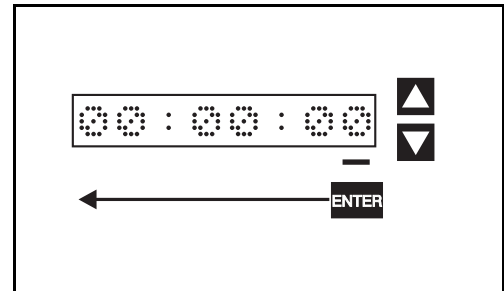

Selection

- * Step upwards in the selection list with ▲
- * Step downwards in the selection list with ▼

The selection will be automatically accepted after approx. 1 sec.

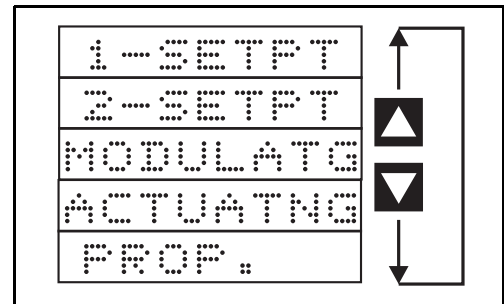

5.5 Operating modes

The setpoint is provided through the menu “System state” (operating level) in the active operating mode (basic status, manual operating mode, automatic operating mode).

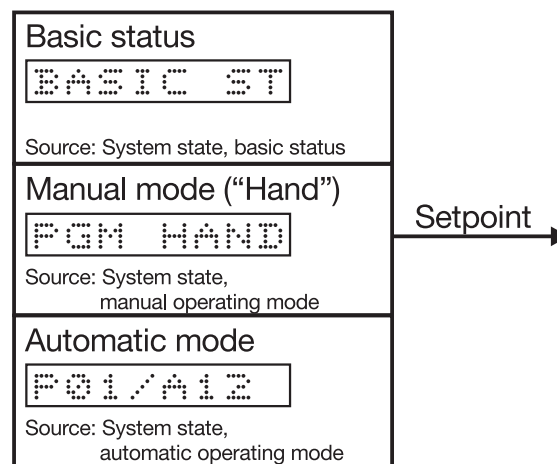

5.5.1 Basic status

Ex-factory, the controller is switched off (inactive) in basic status. No setpoint input is possible.

The controller can be activated for the “basic status” operating mode via the setup program. Only then can the setpoint be input.

5 Operation

5.5.2 Manual operating mode

For start-up and testing, a setpoint, the states of the operating contacts and the active parameter set can be input manually.

Operating level The settings can be made at the operating level, under the menu item “System states”.

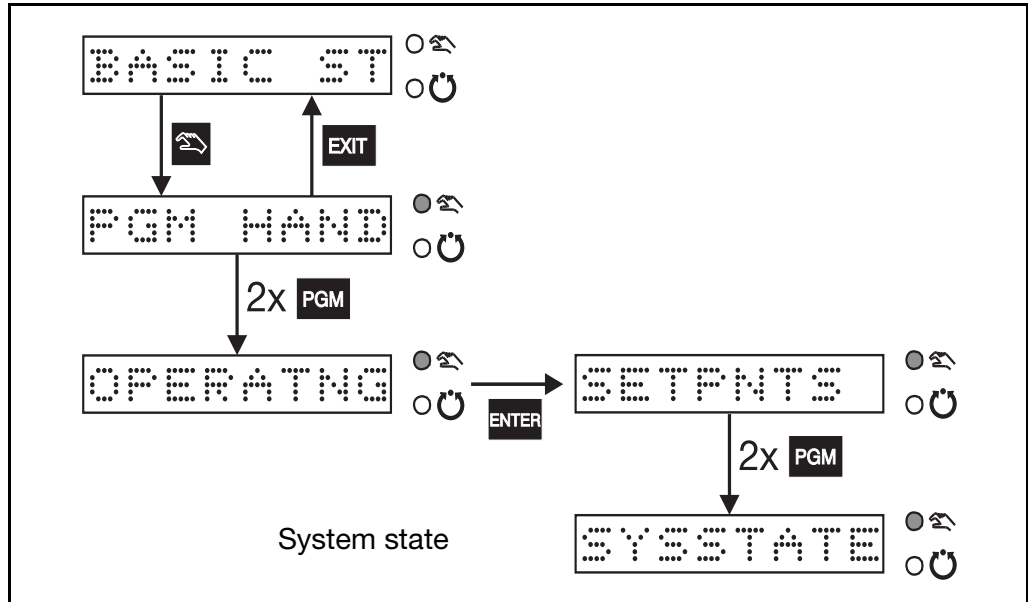



OPERATING → SYSSTATE

	Parameter	Value/selection	Description
Setpoint of manual mode	→ SETPOINT	0.	lower setpoint limit ... upper setpoint limit
Operating contact 1–8	→ OPCNTCT1	ON OFF	ON OFF
Parameter set	→ PARA.SET	1	1–2

5.5.3 Automatic operating mode (program run)

Starting the profile program

The profile program is started with the program no. that was selected under *Program start* → *Program number*.

- * Start program with 
- * Cancel current program with 

A program can also be selected, started and cancelled via the logic functions. The logic function “Program selection” has priority over the settings at the “Program start” level.

Altering the segment setpoint in current profile program

During a program run (automatic mode), the segment setpoint of the subsequent segment can be altered while the program is running.

- * Alter the next segment setpoint with  and 

The segment setpoint is altered temporarily, which means that when the program is restarted, the alteration will be lost.

- a - Setpoint profile on alteration in the current segment
- b - Setpoint profile on restart, after a supply failure or with repeat cycles

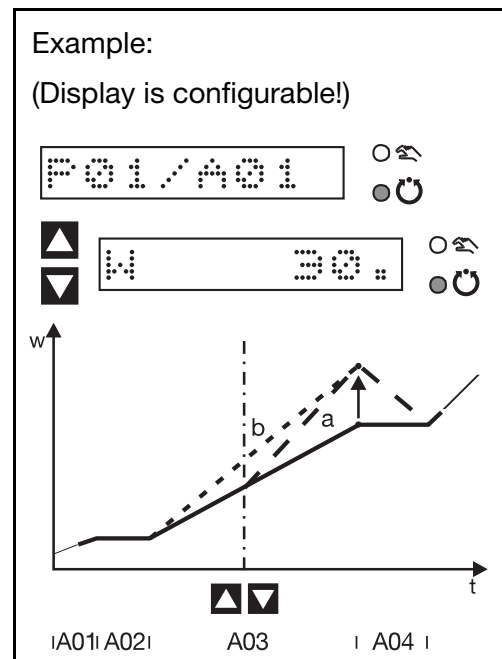

Change of segment

By pressing the key combination for segment change, the program continues at the start of the subsequent segment.

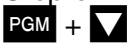

- * Step on to the next segment with 

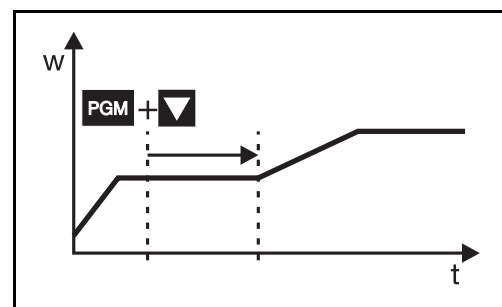
or via the logic function



Holding the profile program

The current program can be held by changing over to the “Program stop” state.

- * Hold program with 
 - * Continue program with 
- or via the logic function

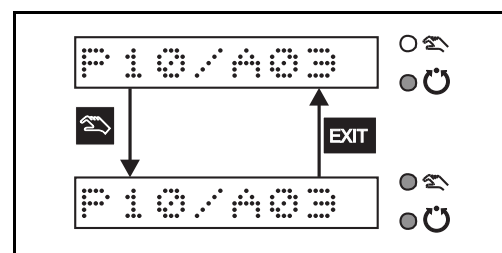

5 Operation

5.6 Shifting the setpoint

Shifting the profile

Using the “external setpoint with correction” function, the profile can be shifted upwards or downwards by the amount of the analogue input.

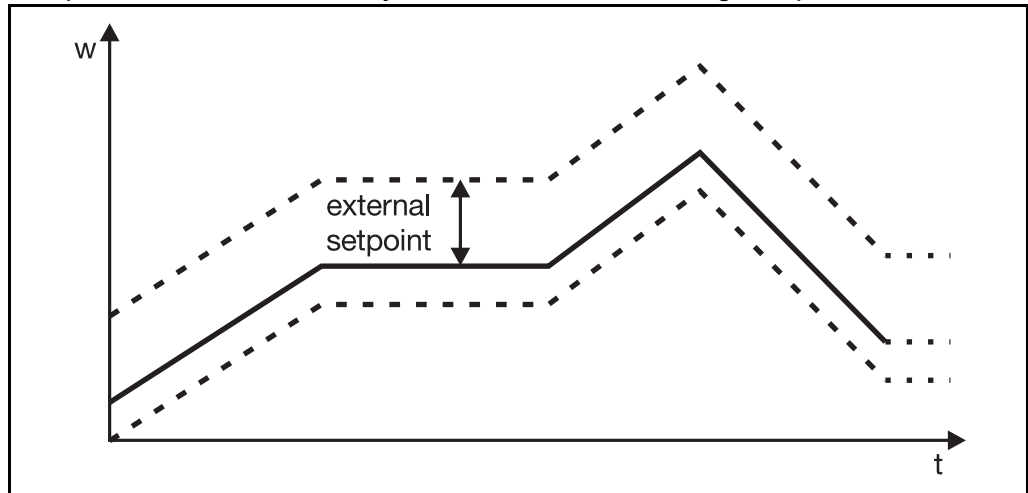

The external setpoint is provided via one analogue input or through mathematics.

Relevant settings

Configuration level 1 → Controller → Controller inputs

Configuration level 1 → Inputs → Analogue input 1–4

Configuration level 1 → Maths/Logic → Mathematics 1+2

5.7 Altering setpoints

In each operating mode, the setpoint can also be altered directly from the keys.

Example:

- * Alter setpoint in the manual mode with ▲ and ▼; shift decimal point with ENTER + ▲ und ENTER + ▼ (The entry is documented in the matrix display)

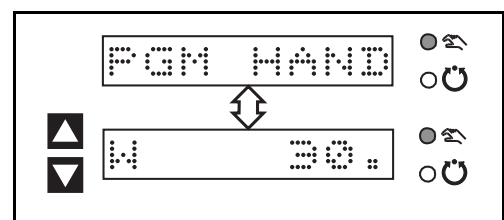

5.8 Setpoint switching

If setpoint switching has been programmed, the active setpoint is modified from the keys.

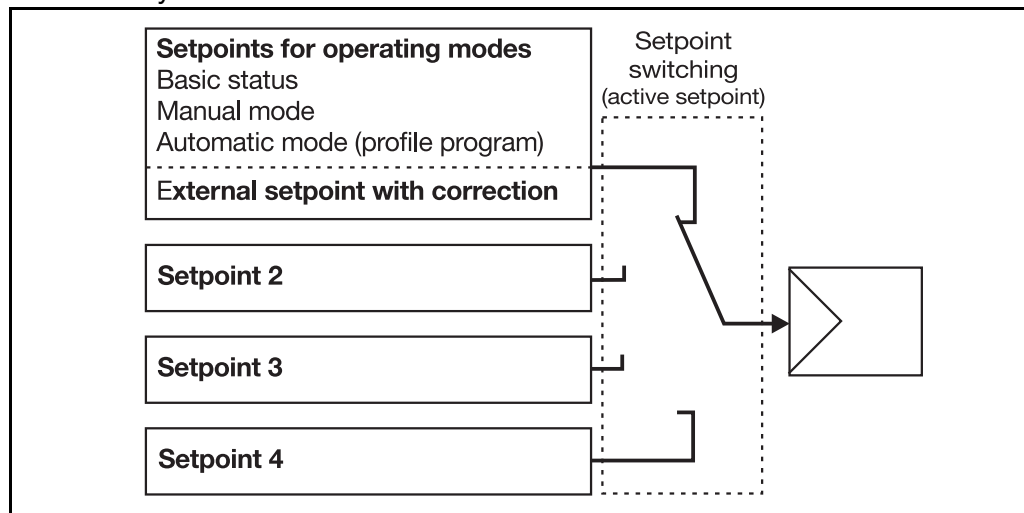

Setpoint inputs via the interface have priority.

Predefined external setpoint

When predefining an external setpoint, setpoint switching takes place as shown in the diagram below:

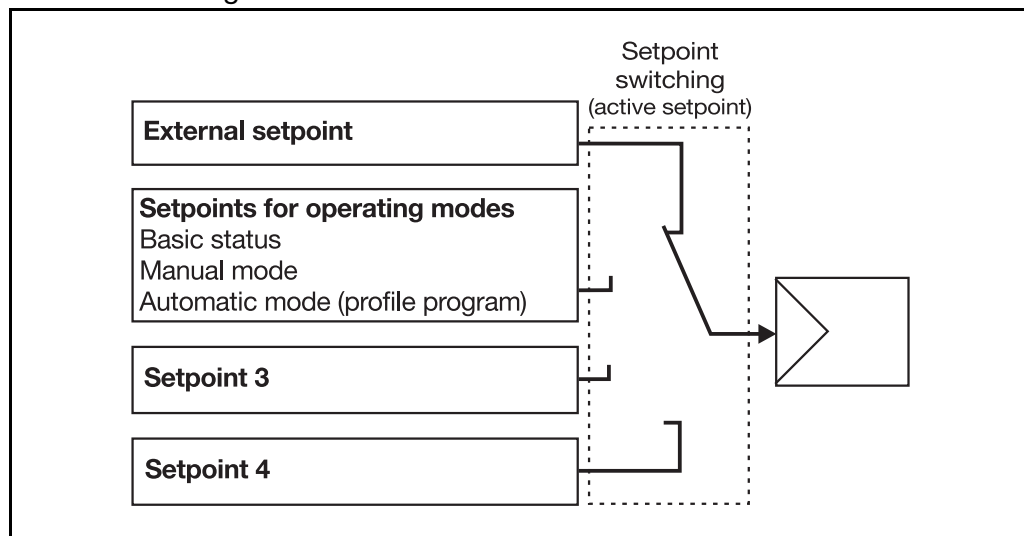

Relevant settings

Operating level → Setpoints

Operating level → System state → Setpoint

Configuration level 1 → Controller → Controller inputs

Configuration level 1 → Controller → Setpoint limits

Configuration level 1 → Logic functions

5 Operation

5.9 Display switching

Two display configurations can be defined which determine the display of values and process variables on the 7-segment displays and the dot-matrix display.

The presentation in the dot-matrix display is only active in automatic mode.

* Switch display with **ENTER**

or automatic changeover after an adjustable time period.

Display switching can be de-activated.

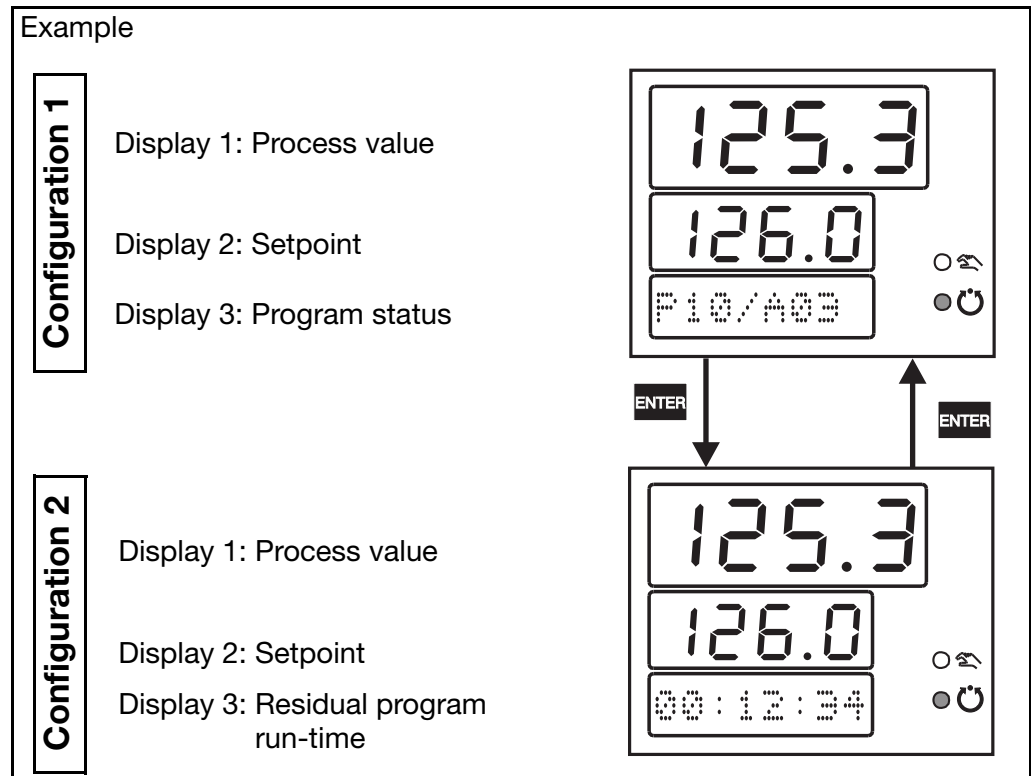



Relevant settings

Configuration level 1 → Display → Configuration 1+2

Configuration level 1 → Display → Automatic display changeover

6.1 Instant start of program

The program is started with the program no. that was selected under *Program start* → *Program number*.

- * Start program with 
- * Cancel current program with 

A program can also be selected, started and cancelled via the logic functions. The logic function “program selection” has priority over the settings at the “program start” level.

6.2 Delayed start of program

Two options are available for starting a program at a specific time:



Real-time clock active 1. With active real-time clock, by entering the start time and start day.

Real-time clock inactive 2. With inactive real-time clock, by entering the delay time.

⇒ Chapter 8 “Operating level”

 The settings are reset to their normal values after the start of the program.

Start/Cancel delay of program start

- * Start program delay-time with 
- * Cancel program delay-time with 

The LED associated with automatic operation blinks.

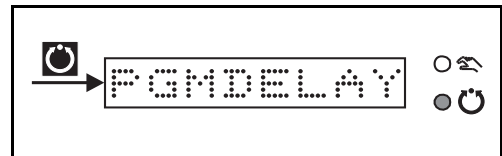

PGMSTART

	Parameter	Value/selection	Description
Program number	→ FROG.NO.	1 .	1–10
Start time	→ START	00 : 00 : 00	00:00:00 – 23:59:59
Start day	→ STARTDAY	SO	SO – SA
Delay time	→ DLYTIME	00 : 00 : 00	00:00:00 – 23:59:59
Start segment	→ STARTSEG	1 .	1 – 100 Segment number at which a start is made
Residual segment time	→ RESIDSEG	00 : 00 : 00	00:00:00 – 23:59:59 Residual run-time of the start segment

Factory settings are shown **bold**.

6 Profile program start

7.1 General

10 profile programs with up to 100 segments can be programmed; a total of 100 segments can be implemented.

Profile programs are defined by programming setpoints and segment times or gradients segment by segment.

The type of instrument programming (setpoint/segment time or setpoint/gradient) can be configured and applies to the entire programming procedure. When creating profile programs via the setup program, the programming type can be selected for each segment.

In addition, the states of the operating contacts 1 – 8 and the active parameter set can be defined for each segment.

The setpoint profiles can be output as ramps or steps (configurable).

The following diagrams show the output in the form of ramps.

Section 10.5 “Profile controller”

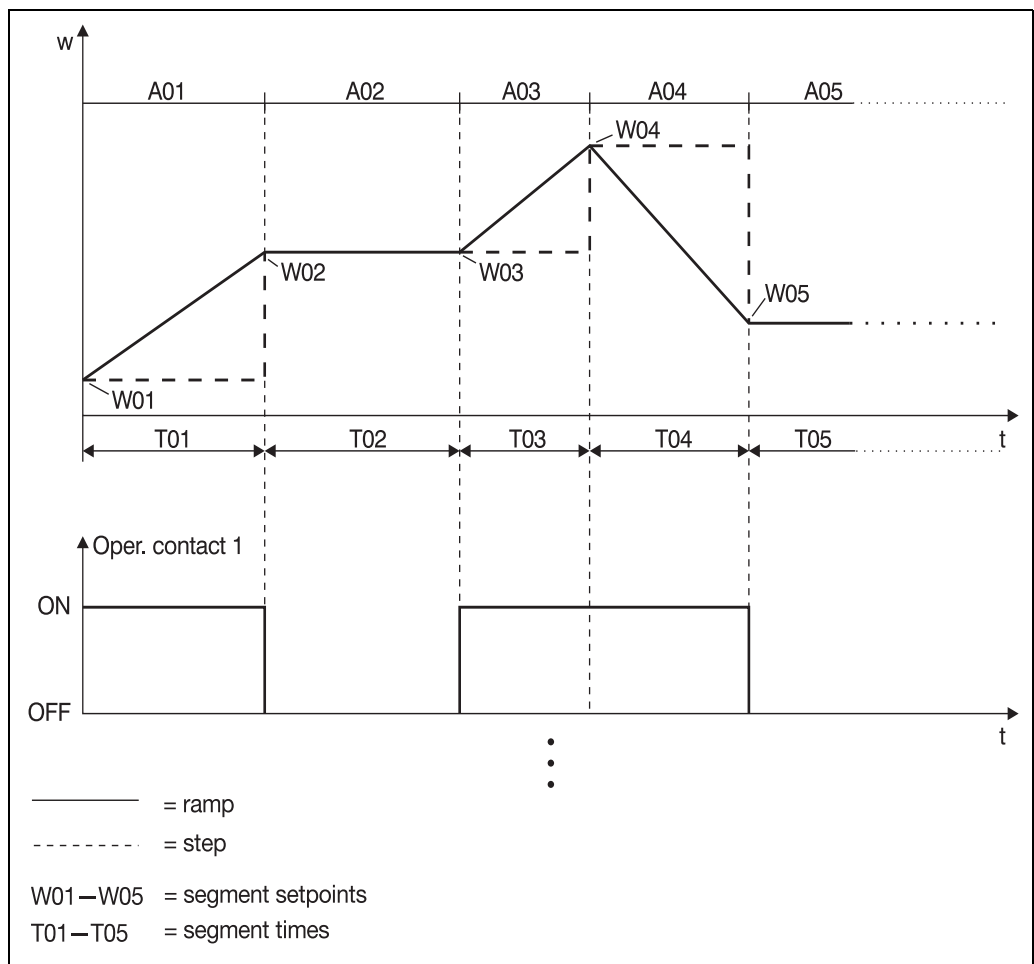

7 Profile program editor

Creating profile programs

When creating profile programs, the segments have to be edited one after another.

- * Change to the program editor with 2x **PGM** and confirm with **ENTER**
- * Enter the code and confirm with **ENTER**
- * Enter the program number and confirm with **ENTER**

Create program by entering the segment setpoint, segment time, etc. The segment number starts at 1 and is incremented automatically.

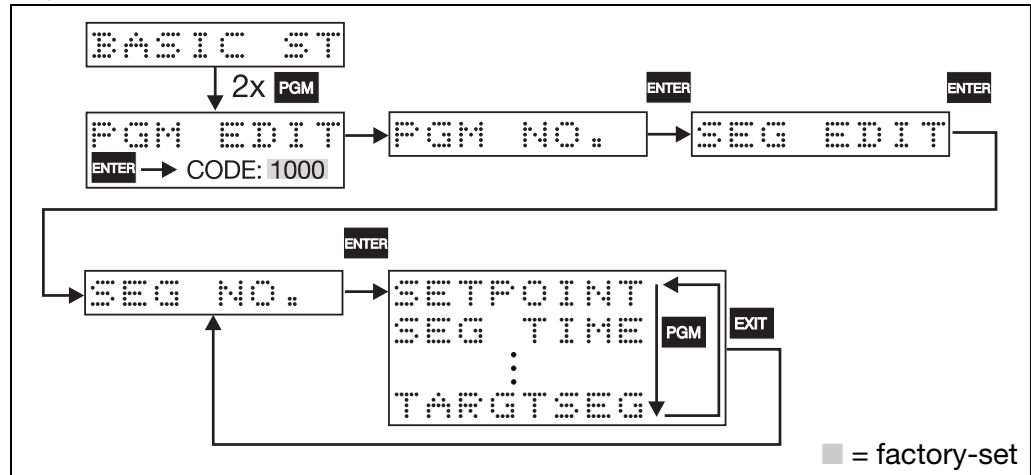

If the segment time is 0, the segment will not be accepted.

All digits must be confirmed with **ENTER**.

The time-out function is not active within the program editor.

⇒ Arrangement of program entry (see cover page)

PGM EDIT → PGM NO. (1–10)

Program editor

Edit segment

- Segment number
- Segment setpoint
- Segment time
- Gradient
- Operating contact 1
- ...
- Operating contact 8
- Minimum limit of tolerance band
- Maximum limit of tolerance band
- Parameter set number
- Repeat cycles
- Zielabschnitt

Parameter	Value/selection	Description
→ SEG EDIT		
→ SEG NO.	1.	1 – 100
→ SETPOINT	0.	Value within the setpoint limits
→ SEG TIME	00:00:00	00:00:00 ... 99:59:59
→ DEGC/MIN	0.	0 – 999
→ OPCNTCT1	OFF	ON OFF
→ OPCNTCT8	OFF	
→ TOL.MIN	-1999.	-1999 to 0 (0 = no limiting)
→ TOL.MAX	9999.	0 to 9999 (0 = no limiting)
→ PARA SET	1	1 – 2
→ CYCLES	0.	-1 – 0 to +99 (-1= infinite)
→ TARGTSEG	1.	1 – 100

Factory settings are shown **bold**.

7 Profile program editor

PGM EDIT → PGM NO. (1–10)

Insert segment

Segment number
 Segment setpoint
 Segment time
 Gradient
 Operating contact 1
 ...
 Operating contact 8
 Minimum limit of tolerance band
 Maximum limit of tolerance band
 Parameter set number
 Repeat cycles
 Target segment

Parameter	Value/selection	Description
→ SEG INS.		
→ SEG NO.	1.	1–100
→ SETPOINT	0.	Value within the setpoint limits
→ SEG TIME	00:00:00	00:00:00 – 99:59:59
→ DEGC/MIN	0.	0–999
→ OPCNTCT1	OFF	ON OFF
→ OPCNTCT8	OFF	
→ TOL. MIN	-1999.	-1999 to 0 (0 = no limiting)
→ TOL. MAX	9999.	0 to +9999 (0 = no limiting)
→ PARA. SET	1	1–2
→ CYCLES	0.	-1–0 to +99 (-1 = infinite)
→ TARGTSEG	1.	1–100
→ SEG COPY		
→ SEG NO.	1.	1–100
→ TARGTSEG	1.	1–100
→ SEG DEL.		
→ SEG NO.	1.	1–100
→ PGM DEL.	0.	-1–10 (-1=delete all programs) factory-set code: 1001

Factory settings are shown **bold**.

7.2 Editing segments

An existing segment can be edited.

The segment number entry is limited by the segment that was defined last.

A segment is defined through the input of a setpoint and a segment time or gradient.

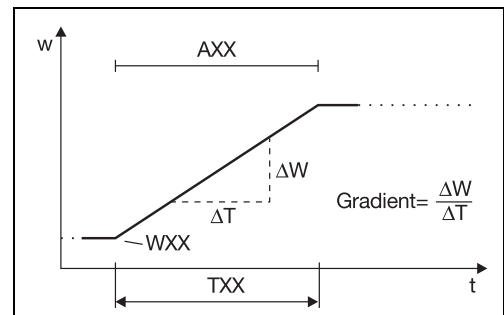

If the segment time is 0, then the segment will not be accepted.

All digits must be confirmed with **ENTER**.

7 Profile program editor

7.3 Inserting segments

Segments can be inserted at any point in the profile. The subsequent segments will be automatically rearranged and re-numbered. The parameters of the segment that was inserted (A02 in the example) are preconfigured to standard default values.

- * Select "Insert segment"
- * Continue with **ENTER**
- * Enter the segment number (in this case: 2)
- * Continue with **ENTER**
- * Enter parameters (at least setpoint and segment time/gradient)
- * Back with **EXIT**

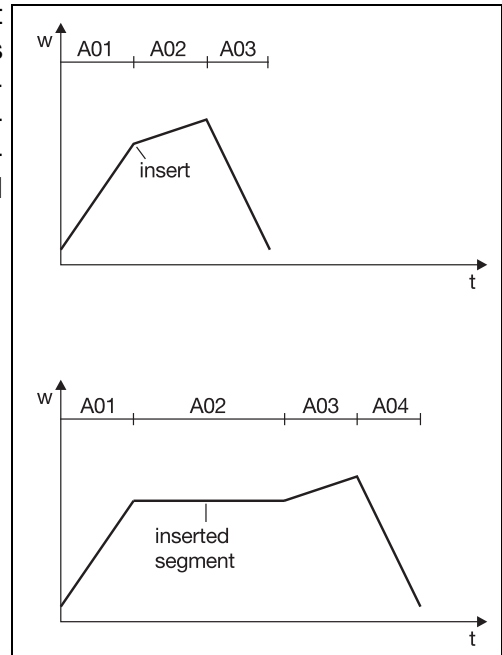

7.4 Copying segments

Segments which have already been defined can be copied to other segments, or can be added to a series of defined segments.

- * Select "Copy segment"
- * Continue with **ENTER**
- * Enter the segment number of the segment to be copied (in this case: 1)
- * Continue with **ENTER**
- * Enter the segment number of that segment to which the data to be copied should be assigned (in this case:4)
- * Confirm with **ENTER**

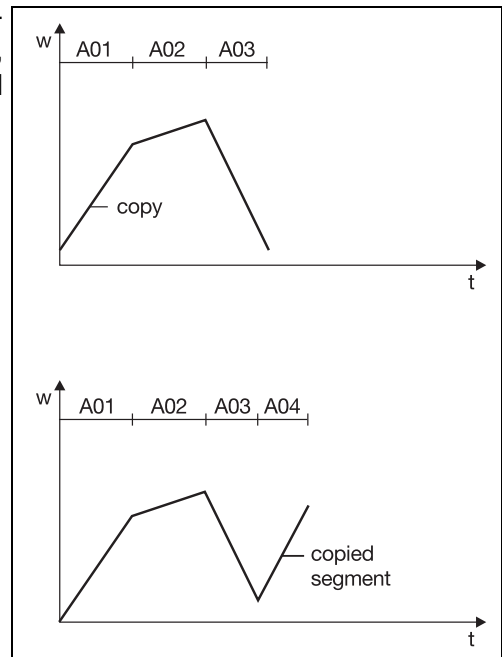

7.5 Deleting segments

When a segment is deleted, the subsequent segments move up and are automatically renumbered. The profile will change according to the preconfigured setpoints.

- * Select "Delete segment"
- * Continue with **ENTER**
- * Enter the segment number of the segment to be deleted (in this case: 2)
- * Confirm with **ENTER**

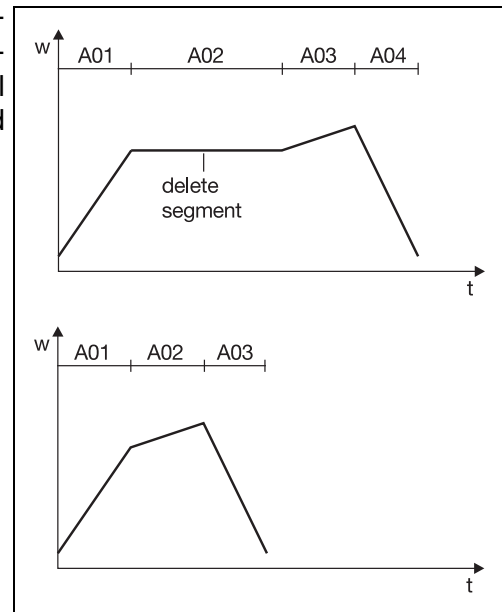

7.6 Programming repeat cycles

A group of consecutive segments can be repeated up to 99 times or indefinitely (input: -1). Repeat cycles are programmed in the menu of the last segment in the group. The first segment of the group is defined in the setting "Target segment".

Example

A02 – A04 are to be repeated once.

- * Edit segment 4
- * Set the repeat cycles to "1"
- * Set the target segment to "2"

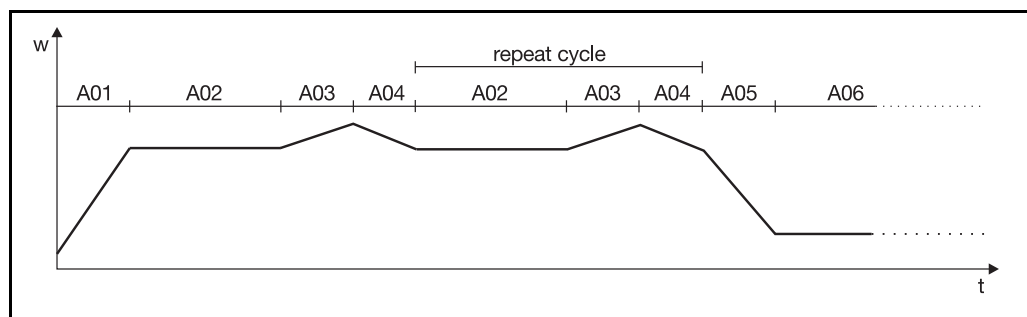

7 Profile program editor

7.7 Temporary alterations

Temporary alterations are alterations to the current profile program in the program editor. They are not stored in the profile program store, which means that the alterations will be lost after a restart.

Curve a:
Setpoint profile after alterations in the current segment

Curve b:
Setpoint profile for subsequent segments or in repeat cycles.

Example:		
Segment	Segment setpoint	Segment time
A01	7	1 h
A02	10	1 h
A03	50	4 h
A04	50	1 h

Altering the setpoint in current segment

When altering the setpoint at time t_0 , the setpoint profile continues with the setpoint that was entered. During the residual segment time (= remaining runtime of the segment), the setpoint of the subsequent segment is approached (curve a).

Example: Alteration in A03
Segment setpoint w_{03} : 10 → 60

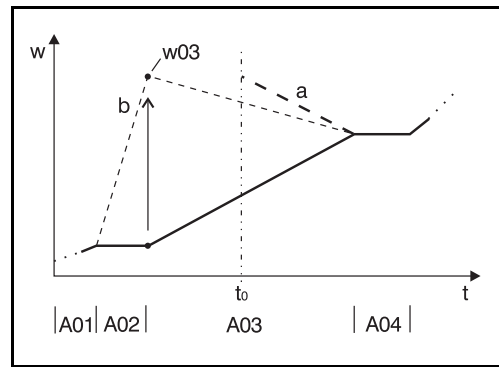

Altering the setpoint in subsequent segment

On alteration at time t_0 , the setpoint that was entered will be approached during the residual segment time. The slope of the ramp changes (curve a).

Example: Alteration in A04
Segment setpoint w_{04} : 50 → 60

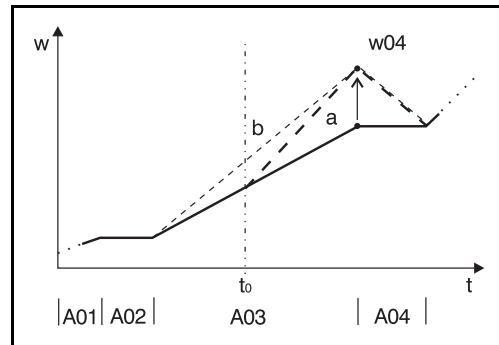

Altering the segment time of current segment

After altering the segment time, the subsequent setpoint will be approached with the remaining (residual) segment time (curve a).

If the new segment time is smaller than the one that has previously elapsed, the setpoint profile will continue at the start of the following segment.

Example: Alteration in A03
Segment setpoint: 4h → 3h

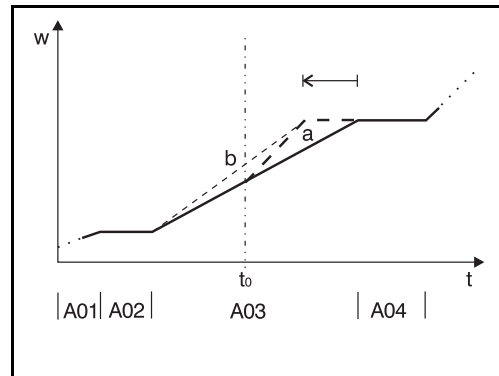

8 Operating level

General

At the operating level, it is possible to display and modify additional setpoints, indicate different process variables and program parameters and set the current system state.

Access level by ...

* pressing **PGM** 3x in the basic status or the manual operating mode.

OPERATING

Parameter	Value/selection	Description
Setpoints Setpoint 1 Setpoint 2 Setpoint 3 Setpoint 4	→ SETPNTS → W1 → W2 → W3 → W4	Value input within the defined setpoint limits w1 has no significance
Process variables Analogue input 1 Analogue input 2 Analogue input 3 Analogue input 4 Mathematics 1 Mathematics 2 Output	→ PROCESS → ANALOG 1 → ANALOG 2 → ANALOG 3 → ANALOG 4 → MATHS 1 → MATHS 2 → OUTPUT	Value display
System state Setpoint Operating contact 1 ... Operating contact 8	→ SYSSTATE → SETPOINT → OPCNTCT1 ... → OPCNTCTS	Value range as for setpoint limits Off On Settings are only valid for the current operating mode (basic status or manual mode)
Parameter set number	→ PARA.SET 1	Value inputs 1 – 2
Program times Program run-time (1) Residual program run-time (2) Max. program run-time (3) Segment run-time (4) Residual segment run-time (5) Max. segment run-time (6)	→ PGM TIME → P RUN-T → P RES.T → P MAX.T → S RUN-T → S RES.T → S MAX.T	Value display
Free segments	→ FREE SEG 100.	Value display Number of program segments which are still free
Real-time clock Function Time Date	→ CLOCK → FUNCTION → TIME → DATE	inactive active 00:00:00 – 23:59:59 Format: DD.MM.YY

Factory settings are shown **bold**.

8 Operating level

Setting the time When the instrument is first switched on, the matrix display will ask you to set the real-time clock.

- * Confirm the message with **ENTER**

The real-time clock is set at the operating level, under the menu *Real-time clock* → *Time*. The time is entered digit by digit.

- * Increase or decrease the value (digit) with **▲** and **▼**
- * Confirm the entry and select the next digit with **ENTER**

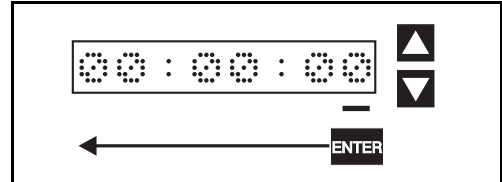
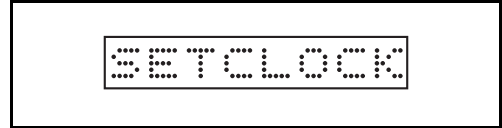

9 Parameter level

- General** Two parameter sets can be stored.
- Access level by ...** * pressing **PGM** 4 times in basic status or the manual operating mode.
- Access code** The level is protected by a code.
factory-set code: 0001
- Selecting the parameter set** Select the parameter set with **PGM**

PARAMETER → PARASET 1

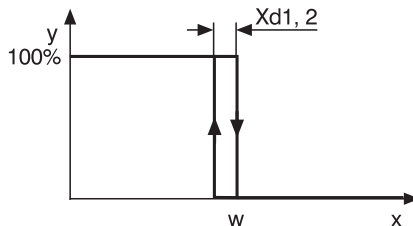
Parameter	Display	Value range	factory-set	Meaning
Controller structure	STR 1	P, I, PD, PI, PID	PID	Structure 2 ¹ refers to the second output in the case of a double-setpoint controller. With modulating controllers, only PI and PID are possible.
	STR 2	P, I, PD, PI, PID	PID	
Proportional band	XP1	0 – 9999 digit	0 digit	Size of the proportional band If $X_{p1,2} = 0$ the controller structure is not effective! (limit comparator action) For proportional controllers, $X_{p1,2}$ must be >0
	XP2	0 – 9999 digit	0 digit	
Derivative time	TV1	0 – 9999 sec	80 sec	Influences the differential component of the controller output signal
	TV2	0 – 9999 sec	80 sec	
Reset time	TN1	0 – 9999 sec	350 sec	Influences the integral component of the controller output signal
	TN2	0 – 9999 sec	350 sec	
Switching cycle time	CY1	0 – 9999 sec	20 sec	For a switching output, the cycle time should be selected so that the switched energy supply does not lead to impermissible measurement fluctuations, while, at the same time, not overloading the switching devices
	CY2	0 – 9999 sec	20 sec	
Contact spacing	XSH	0 – 999 digit	0 digit	Spacing between the two control contacts for double-setpoint controllers, modulating controllers and proportional controllers with integral actuator driver
Switching differential	XD1	0 – 999 digit	1 digit	Differential for switching controllers for $X_p = 0..$ 
	XD2	0 – 999 digit	1 digit	
Stroke time	TT	5 – 3000 sec	60 sec	Utilised stroke time of the control valve on modulating controllers and proportional controllers with integral actuator driver
Working point	Y0	-100 to +100%	0%	Output for P and PD controllers ($y = Y_0$ at $x = w$).

1. Similarly, X_{p2} , T_{v2} , T_{n2} ; C_{y2} ; X_{d2}

9 Parameter level

PARAMETER → PARASET 1

Output limiting	Y1	0 – 100%	100%	Maximum output limit
	Y2	-100 to +100%	-100%	
Minimum relay ON time	TK1	0 – 60sec	0 sec	Limitation of the switching rate on switching outputs.
	TK2	0 – 60sec	0 sec	



The parameter displays on the unit depend on the controller type that was selected.

⇒ Section 10.1 “Controller”

Active parameter set

When parameter set 2 is active, the decimal point on the right of display 2 lights up.

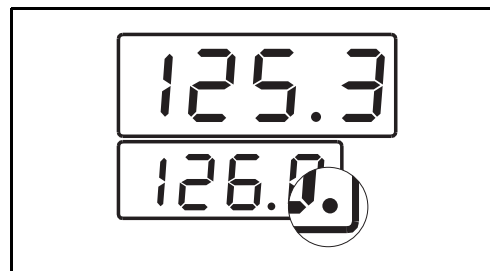

10 Configuration level 1

General The following applies to the representation of parameters and functions on the unit:

The parameter is not displayed when

- the instrument features do not permit the function assigned to the parameter.
Example: Output 3 cannot be configured if output 3 is not available to the instrument.
- the parameter is irrelevant to the function that was previously configured.
Example: Analogue input 1 is configured to "Pt100", which means that display start/end for standard signals will not be displayed.

Access level by ... * pressing **PGM** 5 times in the basic status or in the manual operating mode

Access code The level is protected by a code.
factory-set code: 0002

Overview

→ Controller
⇒ Page 47

→ controller type
control direction
controller inputs

→ process value
external setpoint
external setpoint with correction
stroke retransmission
additive disturbance
multiplying disturbance

setpoint limits

→ setpoint start
setpoint end

manual output
manual operating mode
self-optimisation
output 1+ 2 for self-optimisation
dead band
fuzzy control 1
fuzzy control 2

→ Limit comparators
⇒ Page 49

→ limit comparator 1–8

→ function
action
switching differential
limit value
function on over/
underrange
switch-on delay
pulse function
LK inputs

→ limit comparator PV
→ limit comparator setpoint

→ = press **ENTER** !

10 Configuration level 1

→ Inputs ⇒ Page 52	→ analogue input 1–4	→ transducer linearisation measurement correction constant cold junction temperature external cold-junction temperature	
		display start display end range start range end filter time constant customized recalibration	→ start value end value
	supply frequency unit		
→ Outputs ⇒ Page 57	→ output 1–6	→ function output signal zero point end value output signal on over/underrange	
→ Profile controller ⇒ Page 59	→ function restart program start setpoint input time/gradient programming function control programming	→ controller limit comparator 1–8	
	process value deviation program end time		
→ Maths/logic ⇒ Page 62	→ mathematics 1+2	→ function variable a variable b range start range end linearisation	
	Logic 1+2		
→ Display ⇒ Page 67	→ configuration 1+2	→ display 1–3	→ display value decimal point
	time-out automatic display switching		
→ Logic function ⇒ Page 70	→ logic input 1–8 limit comparator 1–8 logic output 1+2 operating contact 1–8 tolerance band signal program end signal		
→ Interface ⇒ Page 73	→ protocol type data format	→ baud rate parity stop bit	
	unit address minimum response time		

→ = press **ENTER** !

10.1 Controller

The following are set here: controller type and input variables of the controller, setpoint limits, conditions for manual mode, presettings for self-optimisation and the fuzzy logic.

CONFIG 1 → CONTRL.

	Parameter	Value/selection	Description
Controller type	→ CTR. TYPE	1-SETPT 2-SETPT MODULTNG ACTUATNG PROP.	single-setpoint controller double-setpoint controller modulating controller proportional controller with integral actuator driver proportional controller
Control direction	→ DIRECTN.	DIRECT INVERSE	direct inverse inverse: The controller output Y is > 0 when the process value is smaller than the setpoint (e. g. heating). direct: The controller output Y is > 0 when the process value is larger than the setpoint (e. g. cooling).
Inputs of the controller process value external setpoint external setpoint with correction stroke retransmission additive disturbance multiplying disturbance	→ INPUTS → FV → EXTSET → EXTCORR → Y RETRM → ADD DIST → MUL DIST	NO FUNCT ANALOG 1 ANALOG 2 ANALOG 3 ANALOG 4 MATHS 1 MATHS 2	no function* analogue input 1** analogue input 2 analogue input 3 analogue input 4 mathematics 1 mathematics 2 Defines from which analogue inputs or maths functions the controller receives its signals. In the case of a proportional controller with integral actuator driver, stroke retransmission has to be configured! * factory-set for all, except process value ** factory-set for process value

Factory settings are shown **bold**.

10 Configuration level 1

CONFIG 1 → CONTRL.

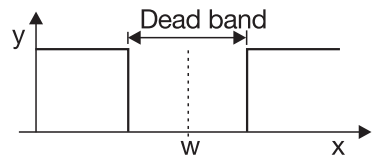
	Parameter	Value/selection	Description
Setpoint limits setpoint start setpoint end	→ WLIMITS → STARTVAL → ENDVALUE	0. 400.	-1999 – 0 to +9999 -1999 – 400 to +9999  The setpoint limits are ineffective with setpoint input via the interface. For external setpoint with correction, the correction value is limited.
Manual output	→ Y MANUAL	101.	-100 – 100 101 = last output Defines the output on over/underrange
Manual operating mode	→ HANDMODE	ENABLED INHIBITD	enabled inhibited
Self-optimisation	→ TUNE	ENABLED INHIBITD	enabled inhibited
Output 1 for self-optimisation	→ TUNEOUT1	RELAY SSRELAY ANOUTPUT	Relay solid-state relay and logic output analogue output type of controller output 1 fro self-optimisation
Output 2 for self-optimisation	→ TUNEOUT2	RELAY SSRELAY ANOUTPUT	Relay solid-state relay and logic output analogue output type of controller output 2 for self-optimisation
Deadband	→ DEADBAND	0.	0 – 999 digit serves to minimise the output movement within the dead band; e. g. with noisy signals.  The dead band is only effective with controller structures with I component.
Fuzzy control 1	→ FC1	0.	0 – 100 0 = fuzzy control off Intensity of the fuzzy signal added to the controller output to improve the control quality.
Fuzzy control 2	→ FC2	30.	0 – 30 – 100 Influences the controller parameters during activated fuzzy module to improve the control quality.

Factory settings are shown **bold**.

10.2 Limit comparators

Limit comparators (limit monitors, limit contacts) are used to monitor an input variable (limit comparator process value) against a fixed limit value or another variable (limit comparator setpoint). When a limit is exceeded, a signal can be output or a function inside the controller initiated.

Limit comparator functions

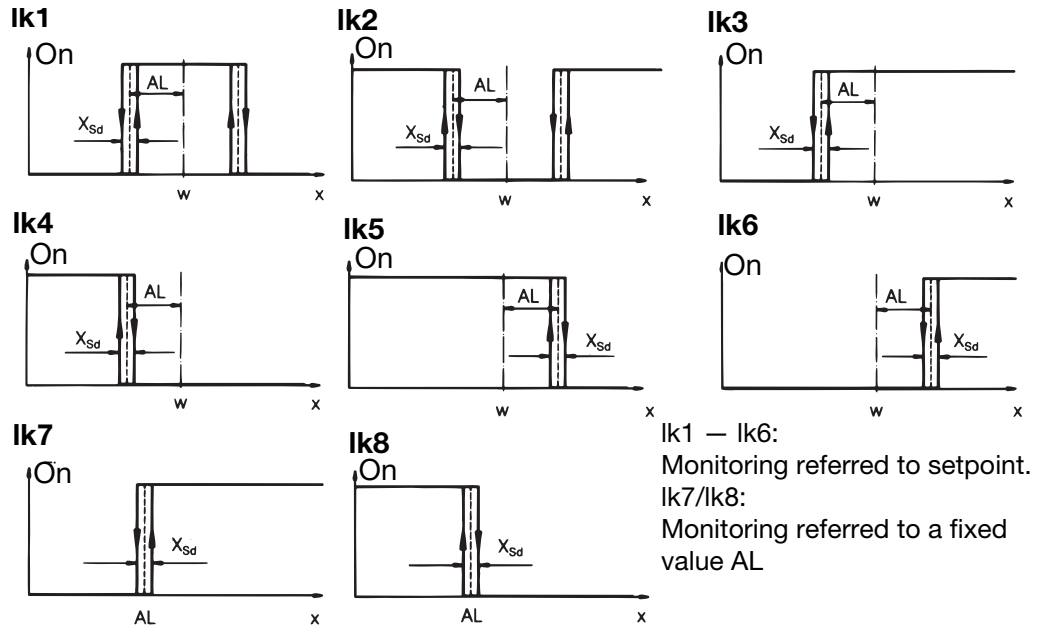

w = limit comparator setpoint, AL = limit value
x = limit comparator process value, X_{Sd} = switching differential

CONFIG 1 → LIMITC

	Parameter	Value/selection	Description
Limit comparator 1	→LIMITC1	-	Configuration of limit comparators as in example "limit comparator 1" below.
...	...	-	
Limit comparator 8	→LIMITC8	-	

Factory settings are shown **bold**.

CONFIG 1 → LIMITC → LIMITC1

	Parameter	Value/selection	Description
Function	→FUNCTION	NO FUNCT LK1 ... LK8	no function function lk1 ... function lk8
Action	→ACTION	ABSOLUTE RELATIVE	absolute relative

Factory settings are shown **bold**.

10 Configuration level 1

CONFIG 1 → LIMITC → LIMITC1

	Parameter	Value/selection	Description
Switching differential X_{sd} Limit value AL Function on over/underrange	→ DIFFERTL	1.	0 – 1 – 9999 digit
	→ LIMIT	0.	-1999 – 0 to +9999 digit
	→ RANGEFACT	RELDE-EN RELENERG	relay de-energised relay energised
		If a limit comparator is connected to an output, then the setting “Output signal on over/underrange” of the output has priority. ⇒ Section 10.4 “Outputs”	
Switch-on delay Pulse function	→ DELAY	0.	0 – 9999sec
	→ PULSEFACT	0.	-1 – 0 to +9999sec The limit comparator is reset automatically after an adjustable interval. -1= The limit comparator has to be reset with the ENTER key or the logic function (all displays off).
Limit comparator inputs Limit comparator process value Limit comparator setpoint	→ INPUTS	ANALOG 1	analogue input 1*
	→ FV LK	ANALOG 4	analogue input 4
	→ SET LK	MATHS 1 MATHS 2 FV SETPOINT RAMPENDV CNTRLDEV OUTPUT	mathematics 1 mathematics 2 process value setpoint (present)** ramp end value control deviation output
			* factory-set on LK process value ** factory-set on LK setpoint

Factory settings are shown **bold**.

10 Configuration level 1

Absolute

At the time of alteration, the limit comparator acts in accordance with its function.

Relative

The limit comparator is in the OFF status.

An alteration of the limit value or the (limit comparator) setpoint could cause the limit comparator to switch ON. Such a reaction will be suppressed, and this condition maintained until the (limit comparator) process value has **moved away** from the switch-on region (grey area).

Example:

Monitoring the (controller) process value x with function lk4
setpoint alteration $w_1 \rightarrow w_2$

a) Initial condition

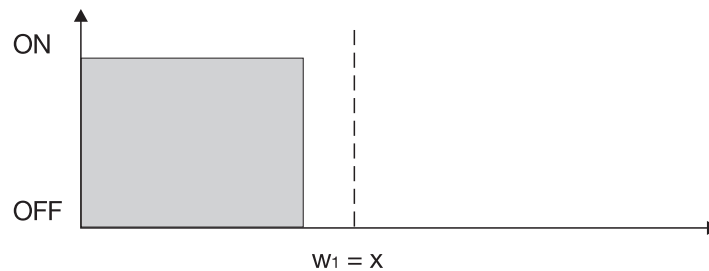

b) Condition at time of alteration.

The limit comparator remains "OFF" although the process value is within the switch-on region.

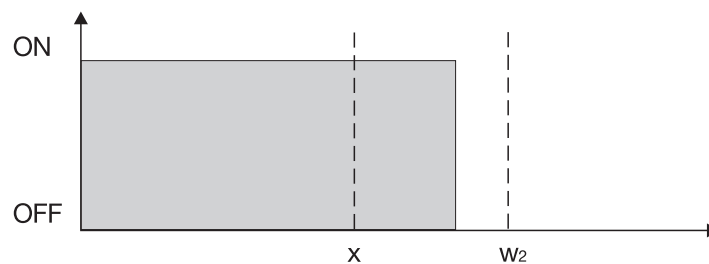

c) Stabilised condition

The limit comparator again operates according to its function.

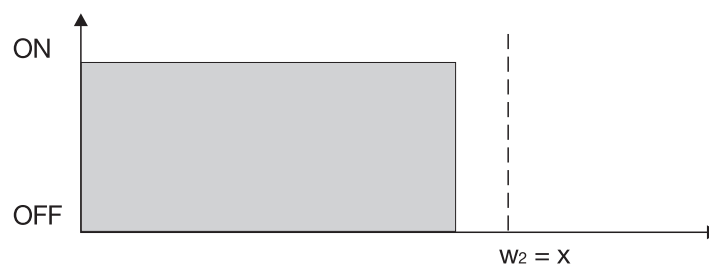

This function also prevents a limit comparator from being triggered during the start-up phase.

10 Configuration level 1

10.3 Inputs

The analogue inputs are configured here.

CONFIG 1 → INPUTS

Parameter	Value/selection	Description
Analogue input 1	→ANALOG 1	Configuration of the analogue inputs as in example "Analogue input 1" below.
...	...	
Analogue input 4	→ANALOG 4	
Supply frequency	→PWRFREQ	50 HZ 60 Hz
Unit	→UNIT	DEGREE C °C DEGREE F °F

Factory settings are shown **bold**.

CONFIG 1 → INPUTS → ANALOG 1

Parameter	Value/selection	Description
Transducer	→PROBE	no function* resistance thermometer** thermocouple (internal cold junction) thermocouple (external cold junction) thermocouple (constant cold junction) potentiometer 0 – 20mA 0 – 1V 0 – 100mV -1 – 1V +/-100mV 4 – 20mA 0 – 10V 2 – 10V +/-10V
<p> The choice of the transducer depends on the hardware configuration of the analogue inputs. -10/0/2–10V and -1–1V will only be indicated with the appropriate hardware configuration.</p> <p>⇒ Chapter 12 "Retrofitting of cards"</p>		

Factory settings are shown **bold**.

10 Configuration level 1

CONFIG 1 → INPUTS → ANALOG 1

Parameter	Value/selection	Description									
Linearisation	→LINTAB	<p>LINEAR linear</p> <p>PT100 Pt 100</p> <p>PT1000 Pt 1000</p> <p>PT500 Pt 500</p> <p>PT50 Pt 50</p> <p>CU50 Cu 50</p> <p>KTY KTY21-6 (1 kΩ at 25°C)*</p> <p>PTK9 Pt K9</p> <p>NI100 Ni 100</p> <p>TC TPE J Fe-Con J</p> <p>TC TPE E NiCr-Con E</p> <p>TC TPE K NiCr-Ni K</p> <p>TC TPE N NiCrSi-NiSi N</p> <p>TC TPE T Cu-Con T</p> <p>TC TPE B Pt30Rh-Pt6Rh B</p> <p>TC TPE R Pt13Rh-Pt R</p> <p>TC TPE S Pt10Rh-Pt S</p> <p>TC TPE U Cu-Con U</p> <p>TC TPE L Fe-Con L</p> <p>CUST LIN customized linearisation**</p> <p>W5RE W26 W5Re-W26Re</p> <p>W3RE W25 W3Re-W25Re</p> <p>W3RE W26 W3Re-W26Re</p> <p>* for other types, see setup program (<i>extended configuration</i>)</p> <p>** for customized linearisation, up to 20 interpolation points can be realised (with setup program only).</p> <p>x = physical measured value</p> <p>y = display value</p>									
	Measurement correction	→OFFSET	<p>0.</p> <p>-1999 – 0 to +9999 digit</p> <p>Measurement correction can be used to correct a measured value by a certain amount upwards or downwards.</p> <p>Examples:</p> <table border="0"> <thead> <tr> <th>measured value</th> <th>offset</th> <th>displayed value</th> </tr> </thead> <tbody> <tr> <td>294.7</td> <td>+0.3</td> <td>295.0</td> </tr> <tr> <td>295.3</td> <td>- 0.3</td> <td>295.0</td> </tr> </tbody> </table> <p> The controller uses the corrected value (= displayed value) for its calculation. This value does not correspond to the actually measured value. If incorrectly applied, this can result in impermissible values of the control variable.</p>	measured value	offset	displayed value	294.7	+0.3	295.0	295.3	- 0.3
measured value	offset	displayed value									
294.7	+0.3	295.0									
295.3	- 0.3	295.0									

Factory settings are shown **bold**.

10 Configuration level 1

CONFIG 1 → INPUTS → ANALOG 1

	Parameter	Value/selection	Description
Constant cold-junction temperature for thermocouples	→ CJTEMP	50.	0 – 50 – 100 digit temperature of cold-junction thermostat
External cold-junction temperature for thermocouples	→ EXTTEMP	ANALOG 1 ... ANALOG 4	analogue input 1 ... analogue input 4 measurement of the cold-junction temperature with a temperature probe
Display start	→ DSPLSTRT	0.	-1999 – 0 to +9999 digit
Display end	→ DISPLEND	100.	-1999 – 100 to +9999 digit On transducers with standard signal and on potentiometers, a displayed value is assigned to the actual signal. Example: 0 – 20mA \triangle 0 – 1500°C. The range of the physical signal can be 20 % wider or narrower without signalling over/underrange.
Range start	→ RNGESTRT	-1999.	-1999 to +9999 digit
Range end	→ RANGEEND	9999.	-1999 to +9999 digit By restricting the measuring range, the instrument will switch earlier to the action defined for over/under-range. Example: Pt100 (range: -200 to +850°C). An alarm message is to be output for temperatures outside the range 15 – 200°C. → Range start: 15 Range end: 200
Filter time constant	→ FILTER	0.6	0 – 0.6 – 100 sec To adjust the digital input filter (0 sec = filter off). At a signal step, 63% of the changes are covered after 2x filter time constant. When filter time constant is large: - high damping of disturbance signals - slow reaction of process value display to process val. changes - low limit-frequency (2nd order low-pass filter)

Factory settings are shown **bold**.

10 Configuration level 1

CONFIG 1 → INPUTS → ANALOG 1

Customized recalibration

Start value
End value

Parameter	Value/selection	Description
→ REC		
→ STARTVAL	0 .	-1999 – 0 to +9999 digit
→ ENDVALUE	1 .	-1999 – 1 to +9999 digit (for explanation, see below) factory-set access code: 0004 Different from all the other settings, the input of the start and end values is linked to the present measured value at the appropriate input. These values cannot be readily accepted by another instrument.

Factory settings are shown **bold**.

Customized recalibration

A signal is processed electronically (conversion, linearisation ...) to produce a measured value via the analogue inputs of the controller. This measured value enters into the calculations of the controller and can be visualised on the displays (measurement = displayed value).

This fixed relationship can be modified if required, this means that the position and slope of the measurement characteristic can be altered.

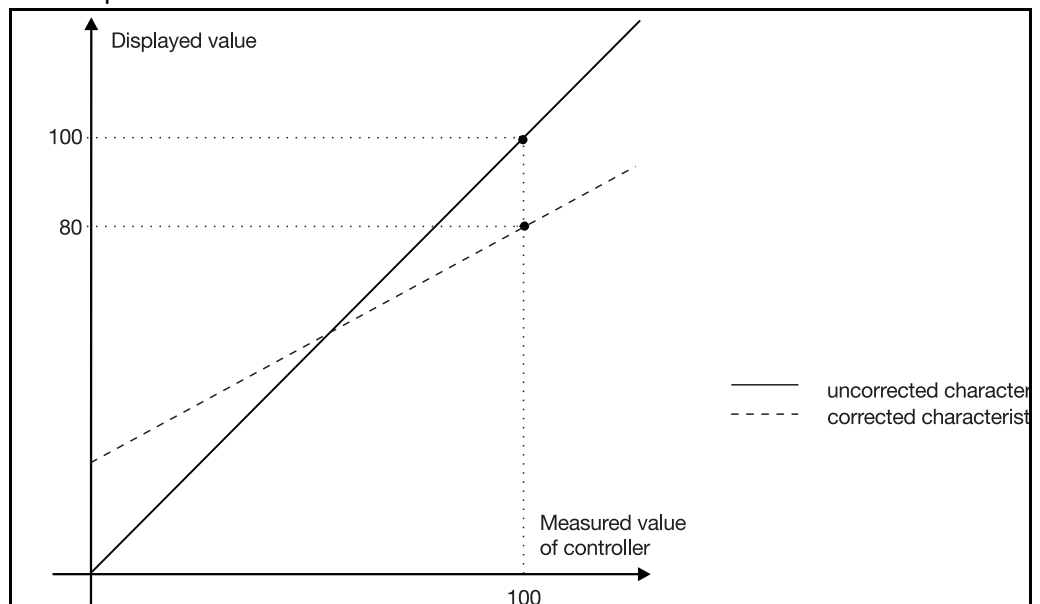

10 Configuration level 1

Procedure

Apply two measurement points ((1), (3)), one after another, to the controller; they should be as far apart as possible.

At these measurement points, enter the required display value (start value, end value) in the controller. A reference instrument is most convenient for determining the measured values M1 and M2.

Measurement conditions must remain stable during programming.

Programming

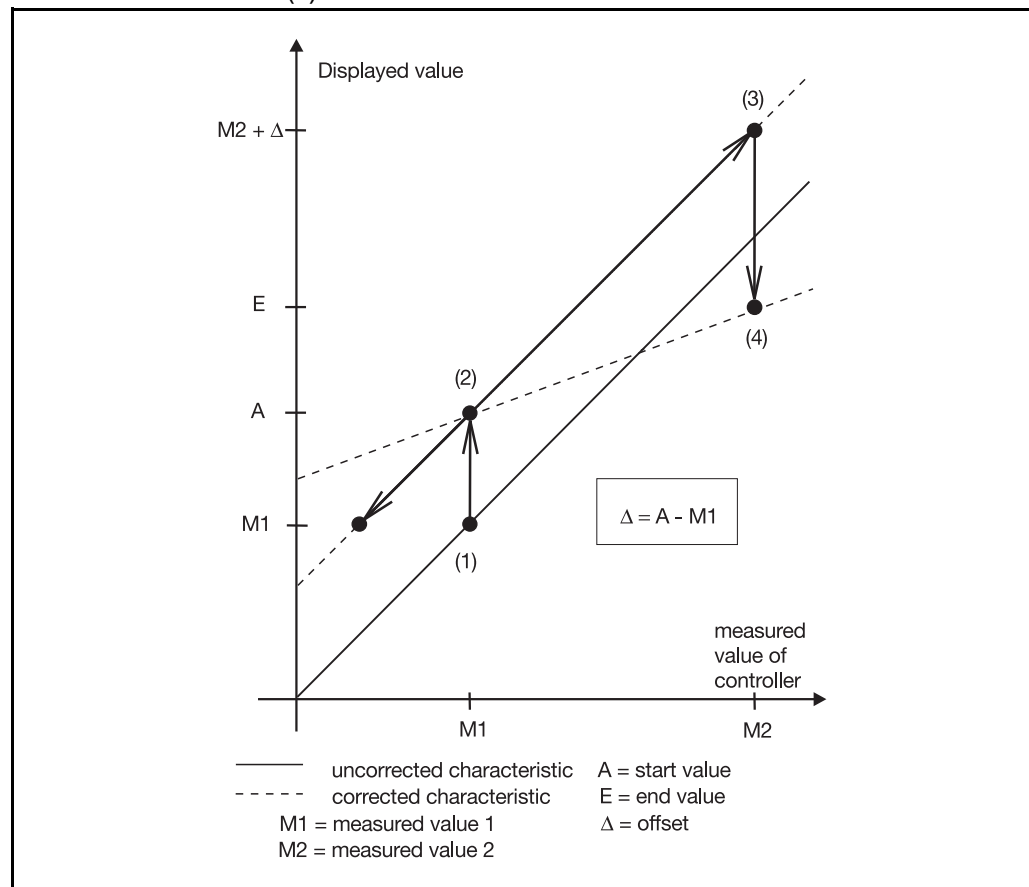

- * Move to measurement point (1)
- * Enter start value (2) ¹
- * Move to measurement point (3)
- * Enter end value E (4) ¹



 If recalibration is carried out without reference instrument, the offset Δ must be taken into account when moving to measurement point (3).

To cancel recalibration, the start and end values have to be programmed to the same value. This sets the start value to 0 and the end value to 1.

Any subsequent recalibration will otherwise be based on the corrected characteristic.

1. If start value=0 or end value=1 is to be set, then the value must first be altered with  or  to enable correction.

10.4 Outputs

The outputs are configured here.

CONFIG 1 → OUTPUTS

	Parameter	Value/selection	Description
Output 1	→OUTPUT1	---	Configuration of the outputs as in the example "Output 1" below.
...	...	---	
Output 6	→OUTPUT6	---	

Factory settings are shown **bold**.



CONFIG 1 → OUTPUTS → OUTPUT 1

	Parameter	Value/selection	Description
Function	→FUNCTION	NO FUNCT	no function*
		ANALOG1	analogue input 1
	
		ANALOG4	analogue input 4
		MATMS 1	mathematics 1
		MATMS 2	mathematics 2
		PV	process value
		SETPOINT	setpoint
		RAMPENDV	ramp end value
		CNTRLDEV	control deviation
		OUTPUT	output
		W1	setpoint 1
	
		W4	setpoint 4
		CTRLOUT1	controller output 1**
		CTRLOUT2	controller output 2
		VALUE XY	address value
		OUT LK1	limit comparator output 1
	
		OUT LK8	limit comparator output 8
		OPCNTCT1	operating contact 1
	
		OPCNTCT8	operating contact 8
		LOGIN B1	logic input 1
	
		LOGIN B8	logic input 8
		LOGIC 1	logic 1
		LOGIC 2	logic 2
		PGM END	program end signal***
		TOLBAND	tolerance band signal
		HANDMODE	manual operation
		TRANSMITT	supply for 2-wire transmitter
			* factory-set on all outputs except output 1
			** factory-set on output 1
			***see also profile program end time

Factory settings are shown **bold**.

10 Configuration level 1

CONFIG 1 → OUTPUTS → OUTPUT 1

	Parameter	Value/selection	Description
Output signal for analogue output	→ SIGNAL	0 – 10 V 2 – 10 V -10 – 10V 0 – 20mA 4 – 20mA -20 – 20mA	0 – 10V 2 – 10V -10 to +10V 0 – 20mA 4 – 20mA -20 to +20mA
Zero point for analogue signals	→ STARTVAL	0.	-1999 – 0 to +9999 digit
End value for analogue signals	→ ENDVALUE	100.	-1999 – 100 to +9999 digit A physical output signal is assigned to the value range of an output variable. Example: Setpoint 1 (value range: 150 – 500°C) is to be output via the analogue output (0 – 20mA). i.e.: 150 – 500°C \triangle 0 – 20mA zero: 150 end value: 500  Setting for controller outputs for cooling. For double-setpoint controllers, the following settings must be predefined: zero: 0 end value: -100
Output signal for over/underrange	→ RANGEFACT	0.	0 – 101* 101= last output signal is retained The output produces a defined signal.  If the output is from a controller, the profile controller (when active) produces the output that was selected under “manual output”. ⇒ Section 10.1 “Controller” * for switching outputs: 0 = off, 1 – 100 = on

Factory settings are shown **bold**.

10 Configuration level 1

10.5 Profile controller

The profile controller/generator is configured here. In addition, the response to a power failure, the profile run and the type of programming are defined here.

CONFIG 1 → PROF CTR

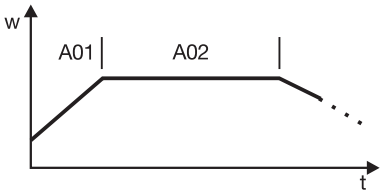
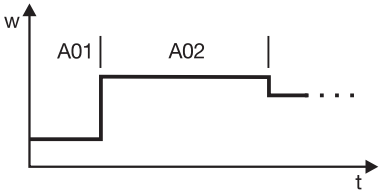
	Parameter	Value/selection	Description
Function	→PROGRFCT	PROFCTRL PROFGEN CTRL.	profile controller profile generator fixed-setpoint controller With the “fixed-setpoint controller” setting, the instrument behaves as for Type 703570/75. ⇒ Operating Instructions B70.3570
Restart after power failure	→RESTART	PGMCANCL CONTINUE STDSTILL CONT X% CONT X	abort profile program continue standstill continue at deviation <x% continue at process value (for explanation, see next page)
Profile program start	→PGMSTART	PGMSTART START X	start at beginning of profile program (w01) start at process value
Setpoint input	→W INPUT	W RAMP W STEP	setpoint ramp setpoint step setpoint ramp:  setpoint step: 
Time/gradient programming	→TIMEGRAD	TIME DEGC/MIN	time gradient Defines in which way segments are programmed when creating new profile programs (profile program editor): - Time: setpoint/segment time - Gradient: setpoint/gradient

Factory settings are shown **bold**.

10 Configuration level 1

CONFIG 1 → PROF CTR

	Parameter	Value/selection	Description
Response on overrange/underrange	→ RANGEFACT	CONTINUE PGM STOP	continue program stop Program stop: The program will be continued after the end of the measurement overrange/underrange.
Function control Controller Limit comparator 1 ... Limit comparator 8	→ FCT CTRL → FCTCLLR → FCT LK1 ... → FCT LK8	GENCTRL OPCNTCT1 ... OPCNTCT8	generator control operating contact 1 ... operating contact 8 Defines when the controller and the limit comparators are active. Generator control: active in automatic mode; otherwise according to defined system state in setup program Operating contact: only active when operating contact is in the ON condition.
Process value deviation	→ X DEV	10.	0 – 10 – 100 digit relevant for restart (continue at deviation <X%)
Profile program end time	→ ENDTIME	0.	-1 – 0 to +9999sec -1 = continuous signal Duration of program-end signal ⇒ Section 10.4 “Outputs”

Factory settings are shown **bold**.

Restart after a power failure

Abort profile program

The program run is aborted; the instrument switches to basic status.

Continue

The program continues from the point at which it was interrupted at the time of the power failure.

Standstill

Outputs, limit comparators, operating contacts and controller behave as defined in the system state “Basic status”.

The program can be continued by pressing the  key, or it can be cancelled by using the **ENTER** key.

Continue at deviation <X%

The program continues from the point at which it was interrupted at the time of power-down, if the difference between the process value before power-down (X_{old}) and the process value after power-on (X_{new}) does not exceed a programmable percentage (process value deviation). If this value is exceeded, the instrument goes into standstill.

10 Configuration level 1

Continue at process value

In the event of a power failure, the sign of the gradient (falling or rising) at the time of the power failure is stored. After the supply voltage has been restored, the program is checked from the beginning to find matching process values and setpoints. The program is continued at the point at which the process value matches the setpoint and the sign of the gradient corresponds to the sign that was stored.

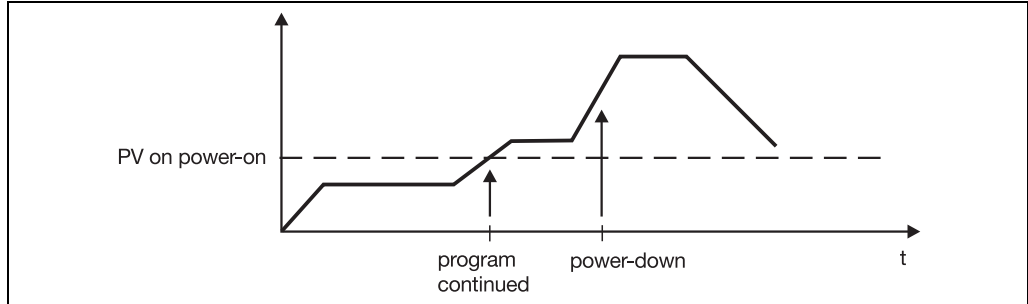

Restart after a power failure

Conditions prior to power-down		(1)	(2)	(3)	(4)	(5)	(6)	(7)	(8)
Conditions after power-on with programmed function...	Profile program aborted	(1)	(2)	(1)	(1)	(1)	(1)	(1)	(1)
	Continue								
	Process value within range	(1)	(2)	(3)	(4)	(5)	(6)	(7)	(8)
	Process value out-of-range	(1)	(2)	(7)	(4)	(5)	(6)	(7)	(8)
	Standstill	(1)	(2)	(7)	(7)	(7)	(6)	(7)	(8)
	Continue at deviation <X%								
	$(ABS(X_{old} - X_{new})/X_{old}) \times 100 \leq X\%$	(1)	(2)	(3)	(4)	(5)	(6)	(7)	(8)
	$(ABS(X_{old} - X_{new})/X_{old}) \times 100 > X\%$	(1)	(2)	(7)	(7)	(7)	(6)	(7)	(8)
	Process value out-of-range	(1)	(2)	(7)	(7)	(7)	(6)	(7)	(8)
Continue at process value									
Process value within range	(1)	(2)	(3)	(3)	(3)	(6)	(7)	(8)	
Process value out-of-range	(1)	(2)	(7)	(7)	(7)	(6)	(7)	(8)	

$X\%$ = process value deviation, X_{old} = process value prior to power-down,

X_{new} = process value after power-on, $ABS()$ = absolute value

- (1) Basic status
- (2) Profile program sequence
- (3) Continue at process value
- (4) Automatic mode

- (5) Profile program stop
- (6) Profile program end
- (7) Standstill
- (8) Manual mode

10 Configuration level 1

10.6 Maths and logic module

This menu is displayed only with enabled maths and logic module.

CONFIG 1 → MATHSLOG

	Parameter	Value/selection	Description
Mathematics 1	→MATHS 1	---	Configuration of mathematics as shown in example "Maths 1" below.
Mathematics 2	→MATHS 2	---	
Logic 1	→LOGIC 1	NO FUNCT FORMULA	no function logic formula (setup program)
Logic 2	→LOGIC 2	NO FUNCT FORMULA	no function logic formula (setup program)

Factory settings are shown **bold**.

CONFIG 1 → MATHSLOG → MATHS 1

	Parameter	Value/selection	Description
Function	→FUNCTION	NO FUNCT DIFFERNC RATIO HUMIDITY FORMULA	no function difference (a-b) ratio (a/b) humidity (a;b) maths formula
Variable a	→VAR A	ANALOG1 ... ANALOG4 MATHS 1 MATHS 2	analogue input 1 ... analogue input 4 mathematics 1 mathematics 2
Variable b	→VAR B	ANALOG1 ANALOG2 ANALOG3 ANALOG4 MATHS 1 MATHS 2	analogue input 1 analogue input 2 analogue input 3 analogue input 4 mathematics 1 mathematics 2
Range start	→RANGESTRT	-1999.	-1999 to +9999 digit
Range end	→RANGEEND	9999.	-1999to +9999 digit Definition of a value range for the result of a mathematical calculation. If the value range is infringed (above or below), over/underrange will be signalled. ⇒ Section 15.2 "Alarm messages and display priorities"

Factory settings are shown **bold**.

10 Configuration level 1

CONFIG 1 → MATHSLOG → MATHS 1

Linearisation

Parameter	Value/selection	Description
→LINTAB	LINEAR	linear
	PT100	Pt 100
	PT1000	Pt 1000
	PT500	Pt 500
	PT50	Pt 50
	CU50	Cu 50
	KTY	KTY21-6
	PTK9	Pt K9
	NI100	Ni 100
	TC TPE J	Fe-Con J
	TC TPE E	NiCr-Con E
	TC TPE K	NiCr-Ni K
	TC TPE N	NiCrSi-NiSi N
	TC TPE T	Cu-Con T
	TC TPE B	Pt30Rh-Pt6Rh B
	TC TPE R	Pt13Rh-Pt R
	TC TPE S	Pt10Rh-Pt S
	TC TPE U	Cu-Con U
	TC TPE L	Fe-Con L
	CUST LIN	customized linearisation
	W3RE W26	W3Re-W26Re
	W3RE W25	W3Re-W25Re
	W3RE W26	W3Re-W26Re

Factory settings are shown **bold**.

Ratio control

The control is always based on variable a.

The maths module forms the ratio of the measurements a and b (a/b) and provides the setpoint for the controller. The ratio of the measured values a and b can be called up and displayed via the functions “Maths 1” or “Maths 2”.

The required ratio a/b is programmed in the setpoint input as setpoint (ratio setpoint).

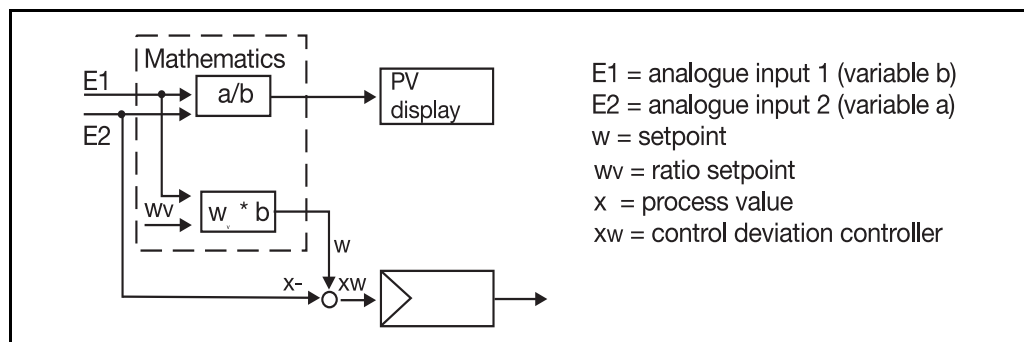

Humidity control

The humidity controller receives the process value from a psychrometric humidity probe through the mathematical linkage of wet bulb and dry bulb temperatures.

Variable a - dry bulb temperature

Variable b - wet bulb temperature

10 Configuration level 1

Formula input

- The formula character string consists of ASCII-characters and has a maximum length of 70 characters.
- The formula can only be entered via the setup program.
- The formulae can be entered freely according to the usual mathematical rules.
- Spaces may be inserted in the formula character string without restriction. No spaces are allowed within function designations, variable names and constants.

Mathematics formula

Mathematical signs and functions

Priority	Mathematical sign/function	Note
high	()	brackets
	SQRT, MIN, MAX, LOG, LN, SIN, COS, TAN, ABS, EXP, INT, FRC	functions
	**	exponent (x^y)
	+, -	sign
	*, /	multiplication, division
	low	+, -

Variables

Variable name	Note
E1 ... E4	analogue input 1 ... analogue input 4
M1 M2	mathematics 1 mathematics 2
X	process value
WR	controller setpoint
WE	segment setpoint of subsequent segment
XW	control deviation
Y	output
W1 ... W4	setpoint 1 (operating level) ... setpoint 4 (operating level)
YH	output heating
YK	output cooling
ADRA	storage address (analogue)
TEMP	temperature at terminals
T0	sampling time
RXK1 RXK2	controller output 1 controller output 2
ADRZ	storage address (time)

10 Configuration level 1

Variable name	Note
ADRB	storage address (binary)
LK1 ... LK8	output limit comparator 1 ... output limit comparator 8
SK1 – SK8	operating contact 1 – operating contact 8
B1 ... B8	logic input 1 ... logic input 8
L1 L2	logic 1 logic 2
PEND	program end
TOL	tolerance band signal

Functions

Syntax	Function
SQRT(a)	square root of a Examples: SQRT(E2) SQRT(13.5+E3)
MIN (a1, a2 ...)	returns the smallest value of a series of arguments Examples: MIN(3, 7) (returns the value 3) MIN(E1, E2, E3, 0.1)
MAX (a1, a2 ...)	returns the largest value of a series of arguments Examples: MAX(3, 7) (returns the value 7) MAX(E1, E2, E3, E3, 0.1)
LOG(a)	logarithm to base 10 Examples: LOG(1000) (returns the value 3) LOG(E1/100)
LN(a)	logarithm to base e Examples: LN(2.71828128) (returns the value 1) LN(E1/100)
SIN(a)	sine of a a in degrees (0 – 360°C) Examples: SIN(90) (returns the value 1) SIN(E1*360/100)
COS(a)	cosine of a a in degrees (0 – 360°C) Examples: COS(180) (returns the value -1) COS (E1*360/100)
TAN(a)	tangent of a a in degrees (0 – 360°C) Examples: TAN(45) (returns the value 1) TAN(E1*45/100)

10 Configuration level 1

Syntax	Function
ABS(a)	absolute value of a Examples: ABS(-12) (returns the value 12) ABS(13.5+E3)
EXP(a)	exponential function e^a Examples: EXP(1) (returns the value 2.718) EXP(E1/100)
INT(a)	integer portion of a Examples: INT(8.3) (returns the value 8) INT(E1)
FRC(a)	decimal portion of a Examples: FRC(8.3) (returns the value 0.3) FRC(E1)

Logic formula

Logic operators

Priority	Operator	Note
high	()	brackets
	NOT, !	negation
	AND, &	AND linkage
	XOR, ^	exclusive OR linkage
	OR,	OR linkage
low		

Edge recognition

Edge	Note
/	variable is "TRUE" only with rising edge (e.g. /B1)
\	variable is "TRUE" only with falling edge (e.g. \B1)

Variables

Variable name	Note
RXK1 RXK2	controller output 1 controller output 2
ADRB	storage address (binary)
Lk1 ... LK8	output limit comparator 1 ... output limit comparator 8
B1 ... B8	logic input 1 ... logic input 8
SK1 ... SK8	operating contact 1 ... operating contact 8
L1	logic 1
L2	logic 2

10 Configuration level 1

Variable name	Note
PEND	program end
TOL	tolerance band signal

Constants

Constant name	Note
TRUE	logic 1
FALSE	logic 0

Enabling the maths and logic module

The maths and logic module can be enabled through a code via the setup program.

⇒ Extras → Enabling extra codes

10.7 Display

The two display configurations are set here, as well as the time-out during configuration at the levels

CONFIG 1 → DISPLAY

	Parameter	Value/selection	Description
Configuration 1	→ DSFCNF1		Configuration of the displays as in the example "Configuration 1" below.
Configuration 2	→ DSFCNF2		
Time-out	→ TIMEOUT	30.	0 – 30 – 9999sec 0 = time-out OFF Interval after which an automatic return to basic status occurs if no key is pressed.
Automatic display switching	→ SCROLL	0.	-1 – 0 – 9999sec 0 = automatic changeover OFF -1 = no switching from keys Interval between switching from one display configuration to the other
Language for instrument texts	→ LANGUAGE	DEUTSCH ENGLISH FRANCAIS ESPANOL	German English French Spanish This feature is available from instrument SW version 050.03.01.

Factory settings are shown **bold**.

10 Configuration level 1

Arrangement of the displays

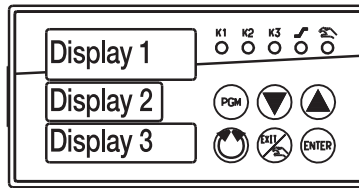

CONFIG 1 → DISPLAY → DEPCONF1

Display 1
Display value

Decimal point

Display 2
Display value

Decimal point

Parameter	Value/selection	Description
→ DISPLAY1 → DISPLVAL	NO FUNCT ANALOG 1 ... ANALOG 4 MATHS 1 MATHS 2 PV SETPOINT RAMPENDV CNTRLDEV OUTPUT VALDISPL	no function analogue input 1 ... analogue input 4 mathematics 1 mathematics 2 process value setpoint (present) ramp end value control deviation output display of a storage address value
→ DECPOINT	XXXX.	XXXX. – X.XXX
→ DISPLAY2 → DISPLVAL	NO FUNCT ANALOG 1 ... ANALOG 4 MATHS 1 MATHS 2 PV SETPOINT RAMPENDV CNTRLDEV OUTPUT VALDISPL	no function analogue input 1 ... analogue input 4 mathematics 1 mathematics 2 process value setpoint (present) ramp end value control deviation output display of a storage address value
→ DECPOINT	XXXX.	XXXX. – X.XXX

Factory settings are shown **bold**.

10 Configuration level 1

10.8 Logic functions

Functions are assigned here to the logic signals of the logic inputs, limit comparators, operating contacts, tolerance band signal, profile program end signal and of the logic module.

CONFIG 1 → LOGICFCT

Parameter	Value/selection	Description
Logic input 1	→LOGIN B1	NO FUNCT
...	...	TUNESTRT
Logic input 8	→LOGIN B8	TUNESTOP
Limit comparator 1	→OUT LK1	W SWITCH
...	...	X SWITCH
Limit comparator 8	→OUT LK8	P SWITCH
Logic 1	→LOGIC 1	KEYINHBT
Logic 2	→LOGIC 2	LEVINHBT
Operating contact 1	→OPCNTCT1	TXTDISPL
...	...	DISPLOFF
Operating contact 8	→OPCNTCT8	AUTOHAND
Tolerance band signal	→TOLBAND	PGMINHBT
Profile program end signal	→PGM END	PGMSTART
		PGMSTOP
		PGMABORT
		PGMSELCT
		FFWD
		NEXTSEG

* A maximum of 10 texts is input and assigned to the logic functions in the setup program.

** The speed of the program run is increased dynamically

The functions are active when the contact is closed or the switching status is "ON".

Profile program start:
The program is started immediately. The start day/start time and delay settings ("program start" level) are ineffective.

All displays off:
- all displays are off
- limit comparators are acknowledged

Text display and all displays off:
response according to priority list

Factory settings are shown **bold**.

10 Configuration level 1

Switching action

The logic functions are activated through logic inputs (floating contacts (switches/relay contacts)), limit comparators, operating contacts or logic.

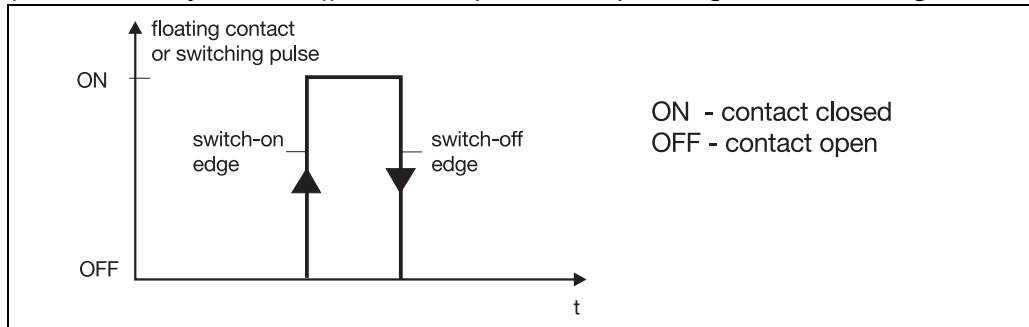

The functions are divided into two groups:

Edge-triggered functions

The logic functions react to switch-on edges.

The following functions are edged-triggered:

- start/stop self-optimisation
- start profile program
- abort profile program
- profile program selection via one logic input only
- acknowledge limit comparators

State-operated functions

The logic functions react to switch-on or switch-off states.

- all other functions

Combined logic functions

A combination of two operating variables (logic inputs, limit comparators, logic and operating contacts) can be used to implement the functions set-point/process value switching.

The profile program selection is realised via three operating variables.

Any operating variable can be selected. The states Z1 – Z2(Z3) are assigned to the operating variables in descending order (see list on the right).

Operating variable	State
Logic input 1	
.	
.	
.	
Logic input 8	
Limit comparator 1	
.	Z1
.	Z2
.	Z3
Limit comparator 8	
Logic 1	
Logic 2	
Operating contact 1	
.	
.	
.	
Operating contact 8	

10 Configuration level 1

Example:

The process value is to be selected via one logic input and the state of one operating contact.

This results in the following assignment:

Z1 - logic input 1

Z2 - operating contact 1

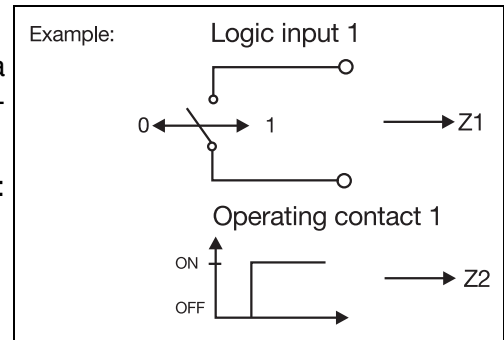

Setpoint switching	Process value switching	Profile program selection	Z3	Z2	Z1
Setpoint of system state/ external setpoint	Configured controller process value	Program 1	0	0	0
Setpoint 2	Analogue input 2	Program 2	0	0	1
Setpoint 3	Analogue input 3	Program 3	0	1	0
Setpoint 4	Analogue input 4	Program 4	0	1	1
-	-	Program 5	1	0	0
-	-	Program 6	1	0	1
-	-	Program 7	1	1	0
-	-	Program 8	1	1	1

0 = contact open /OFF

1 = contact closed /ON



If switching between two setpoints or process values only is required, then only one logic function has to be configured.

If more than two logic functions are configured to setpoint switching (process value switching), then only the first two (see list “operating variable - state”) are significant.

10.9 Interface

CONFIG 1 → INTERFACE

	Parameter	Value/selection	Description
Protocol type	→ PROTOCOL	MODBUS MODINT	MODbus/Jbus MODbus int
Data format Baud rate	→ DATAFMT → BAUDRATE	1200 2400 4800 9600 19200	1200 bps 2400 bps 4800 bps 9600 bps 19200 bps
Parity	→ PARITY	NONE ODD EVEN ZERO	no parity odd parity even parity zero parity
Stop bit	→ STOP BIT	1 2	1 stop bit 2 stop bits
Unit address	→ UNITADDR	0.	0 – 1 – 254
Minimum response time	→ MIN TIME	0.	0 – 500msec Minimum period of time which elapses between the request of an instrument within a data network and the response of the controller

Factory settings are shown **bold**.



Interface description B 703570.2

Interface description B 703560.2.3

10 Configuration level 1

11.1 Self-optimisation

Procedure

Self-optimisation (SO) establishes the optimum controller parameters for PID or PI controllers.

Depending on the controller type, the following controller parameters can be defined:

Reset time (T_{n1} , T_{n2}), derivative time (T_{v1} , T_{v2}), proportional band (X_{p1} , X_{p2}), switching cycle time (C_{y1} , C_{y2}), filter time constant (dF)

The controller selects one of two procedures (**a** or **b**), depending on the size of the control deviation:

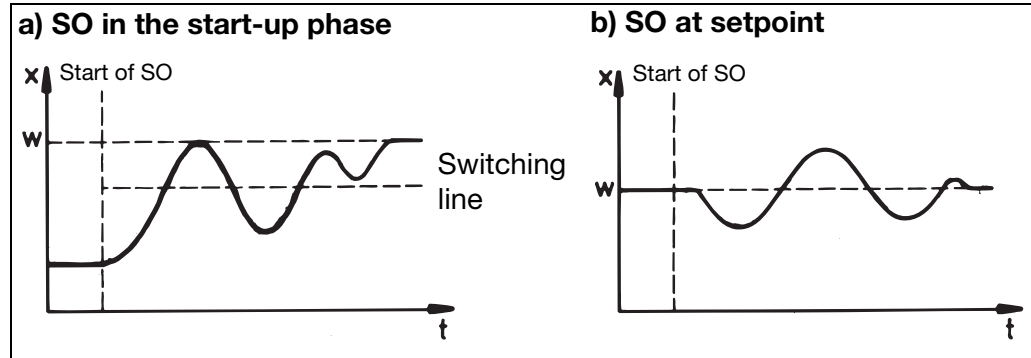

The controller output types have to be defined for self-optimisation.

⇒ Section 10.1 “Controller”

Start of self-optimisation

Self-optimisation is started from the manual mode and is automatically terminated, or can be cancelled.

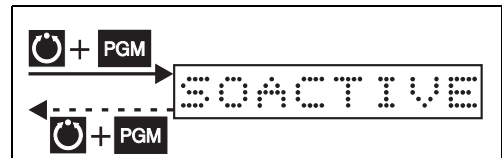

It is not possible to start self-optimisation with activated level inhibit.

11 Optimisation

11.2 Checking the optimisation

Start-up procedure

The optimum adjustment of the controller to the process can be checked by recording the start-up with the control loop closed. The diagrams below indicate possible maladjustments and how these can be corrected.

Control response

The control response of a third-order control loop of a PID controller is shown as an example. However, the procedure for adjusting the controller parameters can also be applied to other control loops.

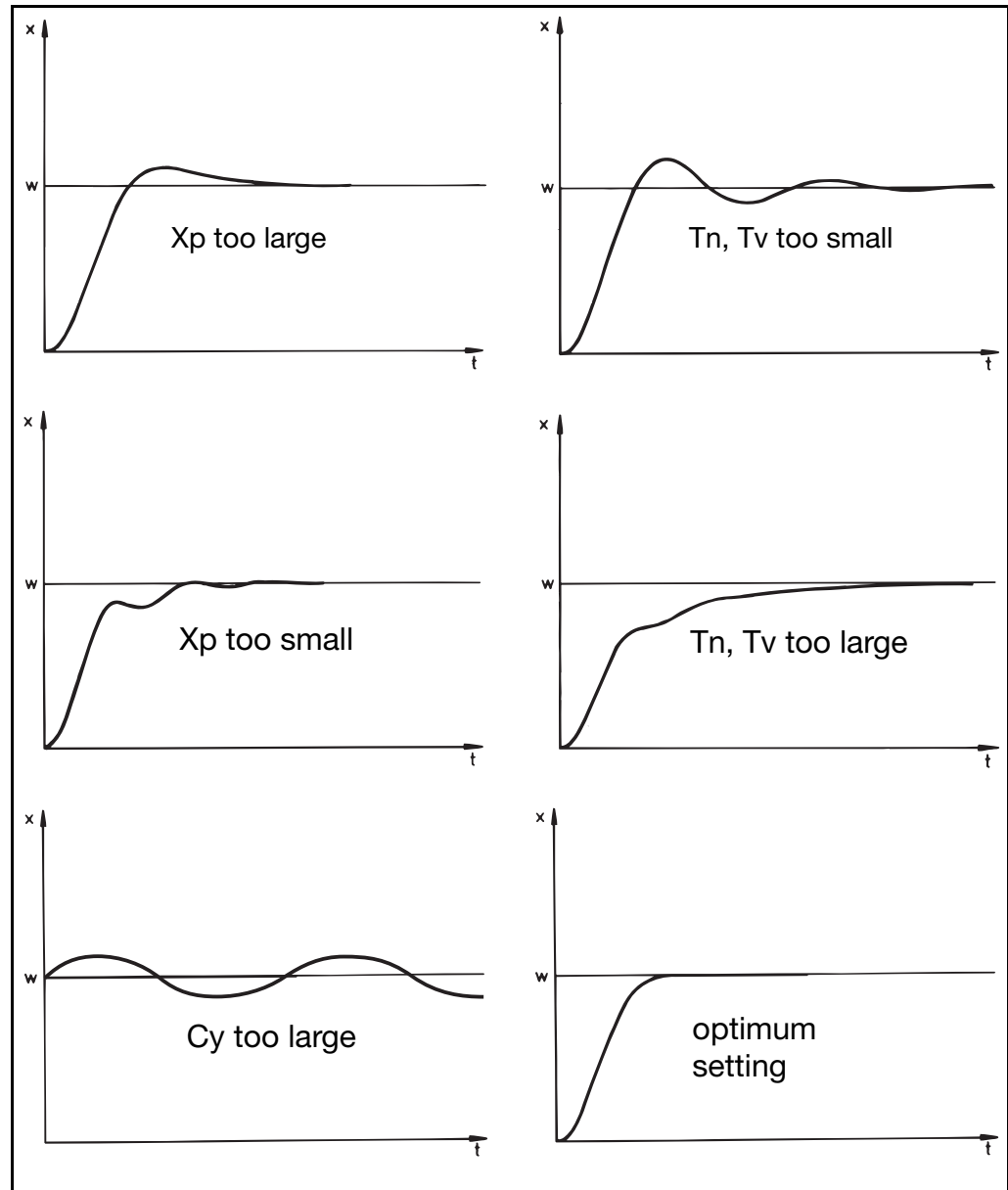

11.3 Fuzzy parameters

In addition to the algorithms for the various controller structures, the controller software also includes a fuzzy module. This can be used to improve both the control and the disturbance response of controllers with I-action.

When the fuzzy module is activated, the output y is made up of the controller output and the output signal of the fuzzy module.

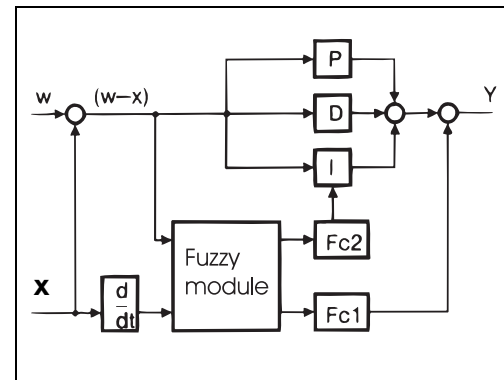

The parameter $Fc1$ affects the intensity of the fuzzy signal:

$Fc1 = 0$: Fuzzy module not activated

$0 < Fc1 \leq 100$: Fuzzy module activated

If the fuzzy module activated by $Fc1$ makes corrections to the output y , the reset time T_n is influenced during correction.

The parameter $Fc2$ is used to adjust the degree of influence on the reset time T_n .

$Fc2 = 0$: no influence on T_n

$0 < Fc2 \leq 100$: influence on T_n

When supplied, and also after self-optimisation, the fuzzy parameters are set to $Fc1 = 0$ and $Fc2 = 30$.

The fuzzy module can be activated at any time by setting $Fc1 > 0$.

The setting $Fc2 = 30$ is suitable for many applications. The optimum setting can be determined with the help of the table below.

11 Optimisation

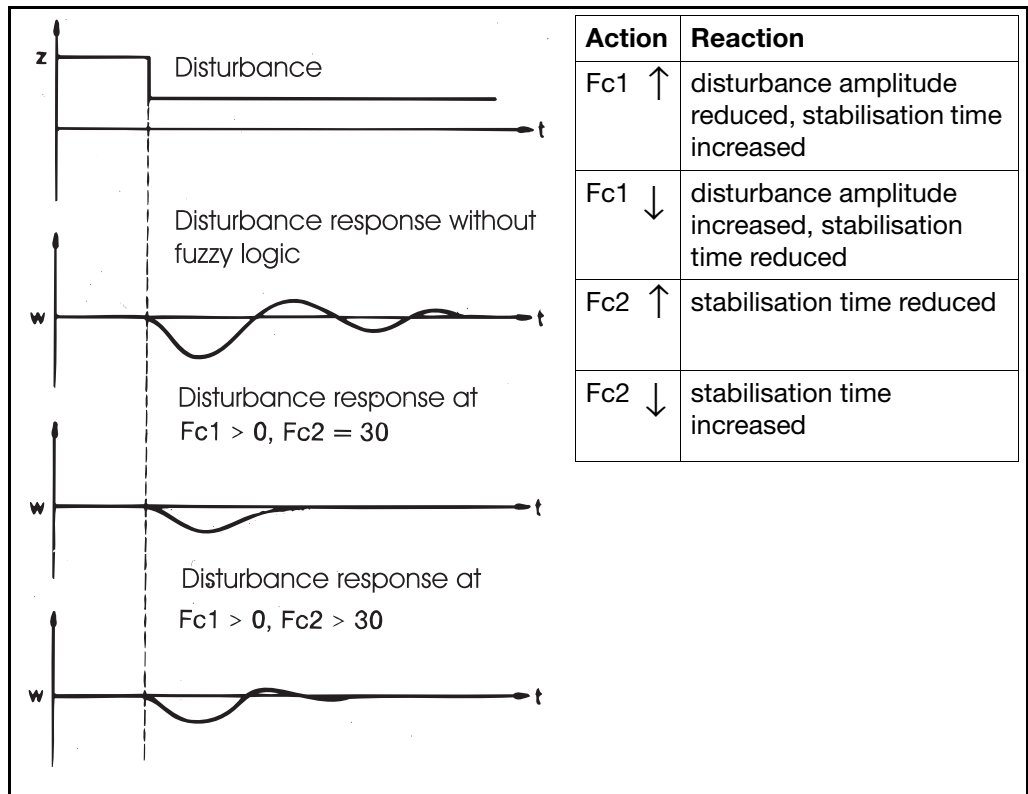

If the fuzzy module is not activated ($Fc1=0$), $Fc2$ is also ineffective.

The action and sensitivity of the fuzzy parameters depend largely on the process to be controlled.

The influence is greater on proportional controllers than on switching controllers.

12 Retrofitting of cards

The following steps are necessary for retrofitting cards:



Only qualified personnel are permitted to retrofit cards.



The cards can be damaged by electrostatic discharges. Avoid electrostatic charges during fitting and removal. Carry out the card change on a workbench which is earthed.

Identifying the card



* Identify the card by the sales no. or part no. that is glued to the packaging

The instrument is fitted from device software version 50.02.XX on with a new type of analog input card. If analog input cards are retrofitted, it must be noted that they cannot be operated together with the older type of card (i.e. do not mix card types). Please note also that an update of the setup program may be required in order to carry out the configuration through the setup program.

The Software-Version appears on the Display if the keys PGM + "arrow up" are pressed.

Cards	Code	Sales No.	Card No.
<u>Analogue input 3 and 4:</u>			
Universal input			
up to software version 50.01.XX	1/2	70/00366099	358457
from software version 50.02.XX on	1/2	70/00490339	483509
<u>Outputs/logic inputs:</u>			
Relay (changeover contact)	1	70/00366100	358444
Solid-state relay 230V 1A	2	70/00366101	358452
Logic 0/5V	3	70/00366102	358445
Logic 0/22V	4	70/00366103	358447
Analogue output	5	70/00366104	358449
Supply for 2-wire transmitter	6	70/00366105	358447
Two logic inputs	7	70/00366106	358450
RS422/485 interface	54	70/00366107	358443
PROFIBUS-DP	64	70/00375280	368705

12 Retrofitting of cards

Configuring the analogue input

The retrofitable analogue inputs 3 and 4 are supplied ex-factory as universal input. They can be reconfigured as voltage input for certain measuring ranges (-10/0/2 – 10V and -1V – 1V).

* Re-arrange push-on jumpers as in the diagram

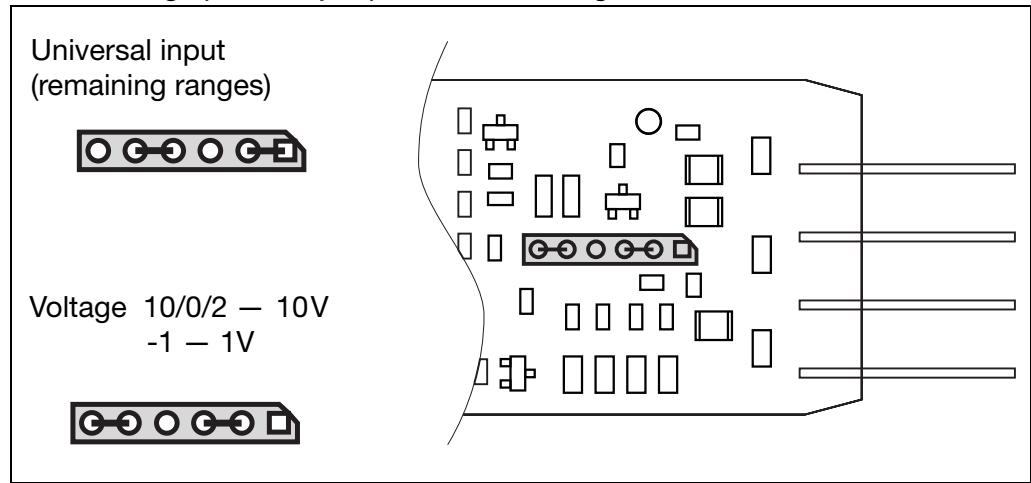

 The standard analogue inputs 1 and 2 are configured ex-factory as universal input or as voltage input for certain measuring ranges (see type designation or order details). They can also be reconfigured:

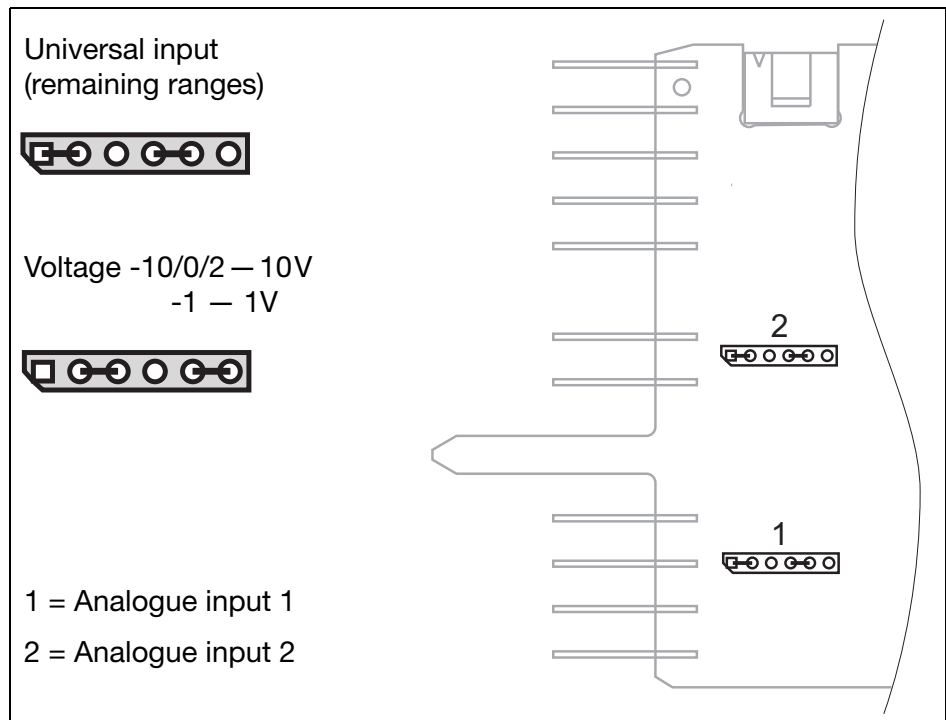

12 Retrofitting of cards

Removing the controller chassis

- * Pull off setup plug
- * Press together the ribbed surfaces on the panel top and bottom (or left and right with landscape format) and pull out the controller chassis.

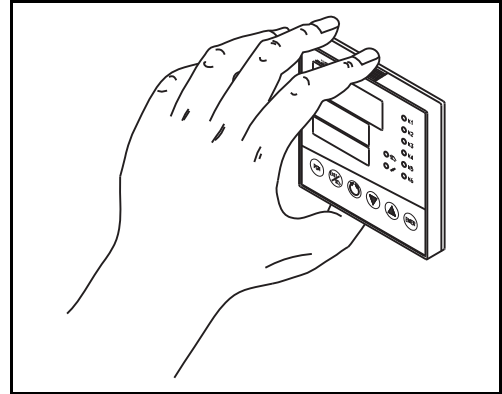

Assigning the slot

- * Determine the corresponding slot for the card

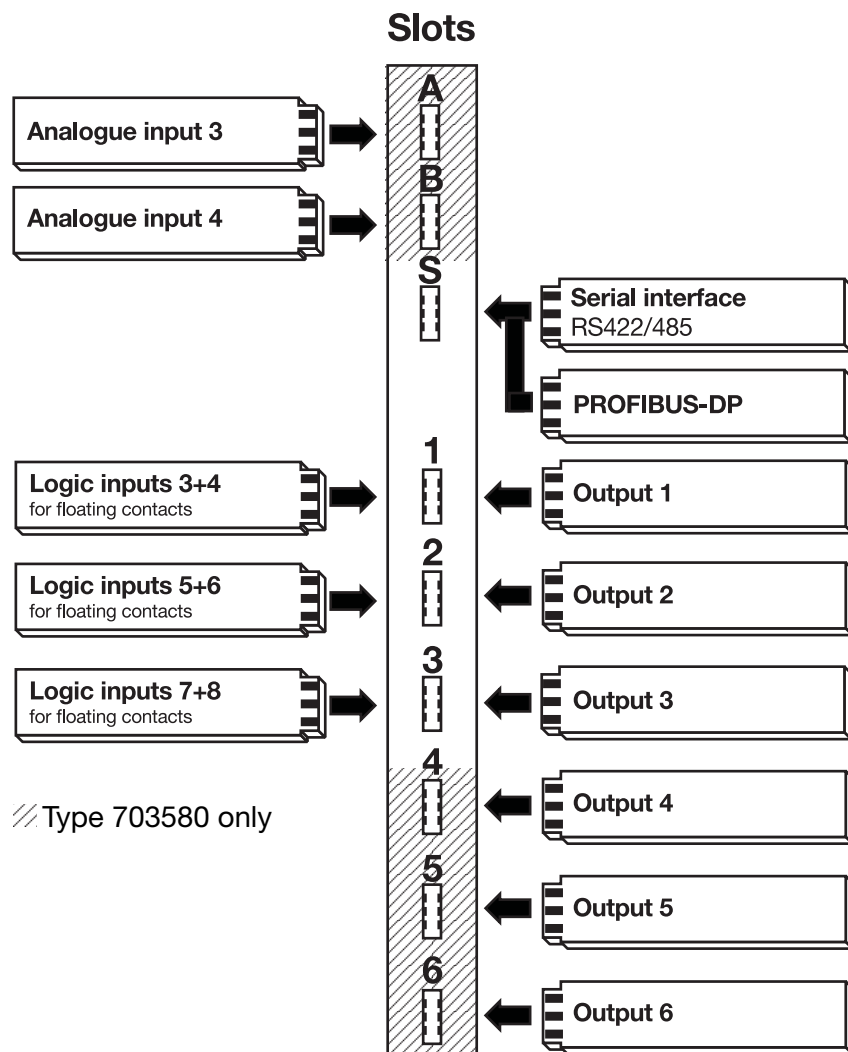

12 Retrofitting of cards

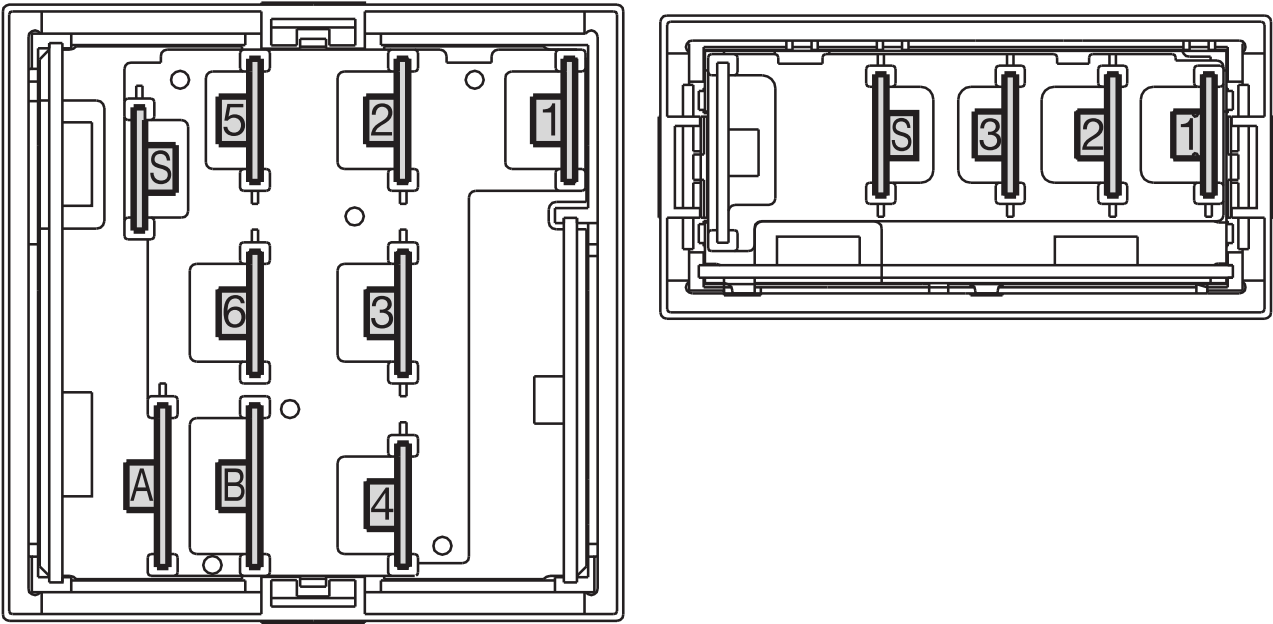

Inserting the card

- * Pull off the guide plate (1)
- * Insert card into the guide until the projections on the card snap into the notches provided (2)

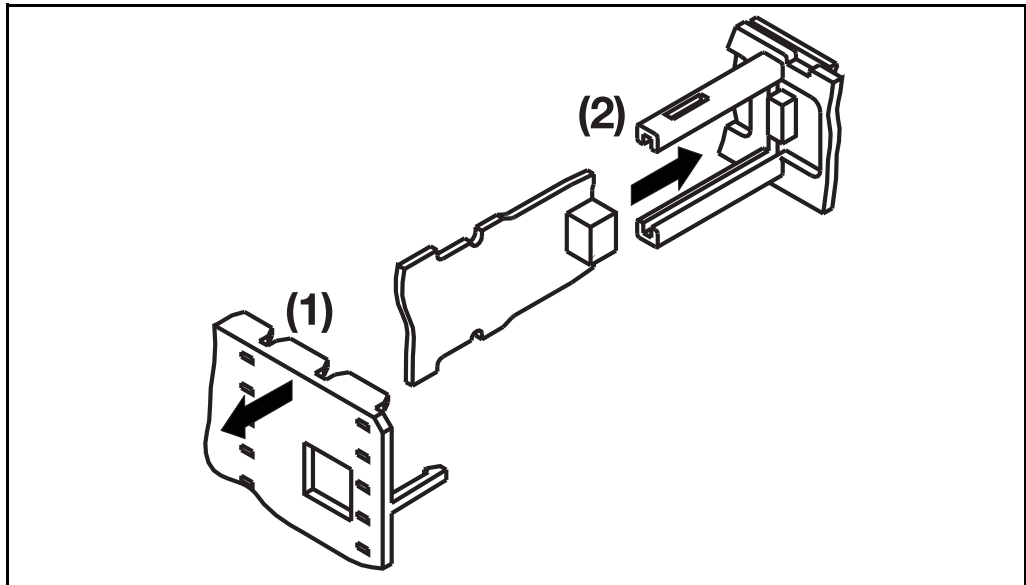

Inserting the controller chassis

- * Fit on the guide plate
- * Push the controller chassis into the case until the lugs (underneath the ribbed surfaces) snap into place.

13.1 RS422/485 interfaces

The controller can be integrated into a data network via the interface. Functions which can be implemented include:

- process visualisation
- system control
- recording/logging

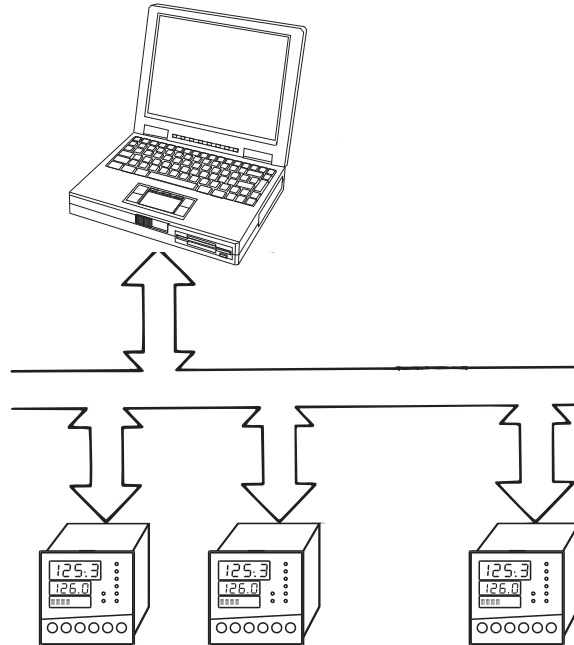

The bus system is based on the master-slave principle. A master computer can address up to 31 controllers and instruments (slaves). The interface is a serial interface to RS422 and RS485 standards.

The following data protocols are available:

- MOD/Jbus protocol



Interface description B 703570.2

13 Interfaces

13.2 PROFIBUS-DP

Fieldbus

The controller can be incorporated into a fieldbus system according to the PROFIBUS-DP standard, via the PROFIBUS-DP interface. This PROFIBUS variant has been especially designed for the communication between automation systems and distributed peripheral devices at the field level, and is optimised for speed.

Data transmission

Data transmission is performed serially, according to the RS485 standard.

GSD generator

With the aid of the project design tool included in the delivery (GSD generator; GSD = Device Base Data), a standardised GSD file is created, which serves to integrate the controller into the fieldbus system, through the selection of characteristic controller features.

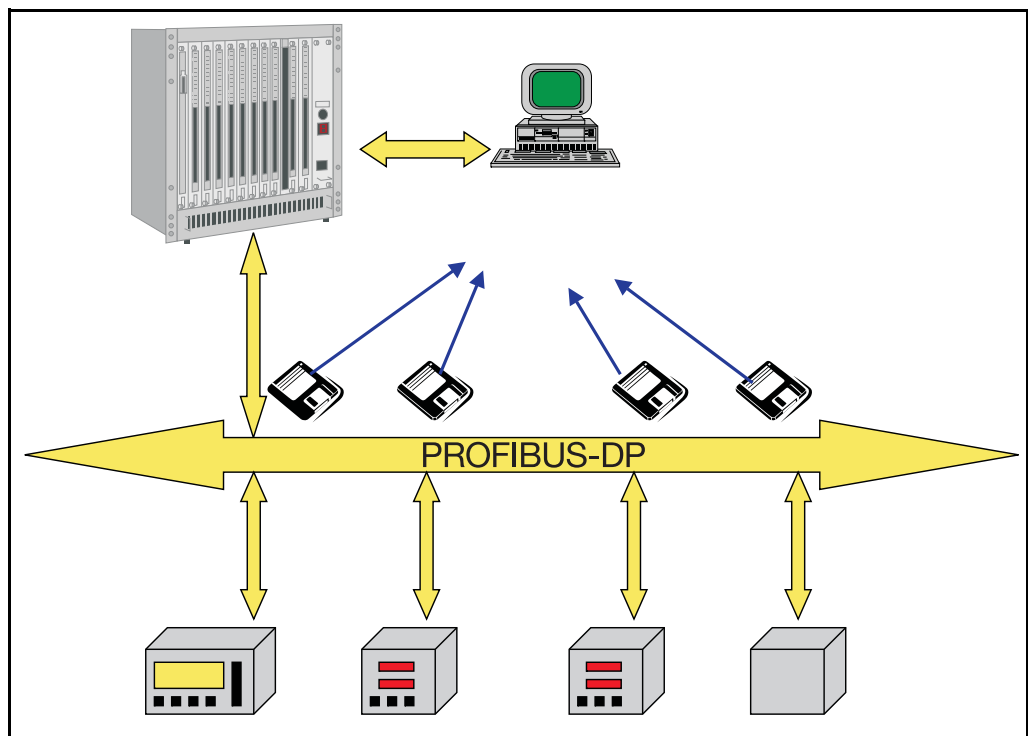

Interface description B 703560.2.3

14.1 External relay module/logic module ER8/EL8

By using the external relay module ER8 or logic module EL8, the controller can be expanded by eight relay outputs (changeover contacts) or logic outputs (0/12 V). Communication with the controller occurs via the RS422/485 interface. All controller signals for switching outputs can be output by the module. Configuration is only possible through the setup program.

⇒ Section 7.4 “Outputs”



If the module ER8/EL8 is connected to the interface, then no further communication is possible via the interface.

Connection

The electrical connection is carried out like the connection to an RS485 interface (the figure below shows ER8; see also Operating Manual ER8/EL8, B 703564).

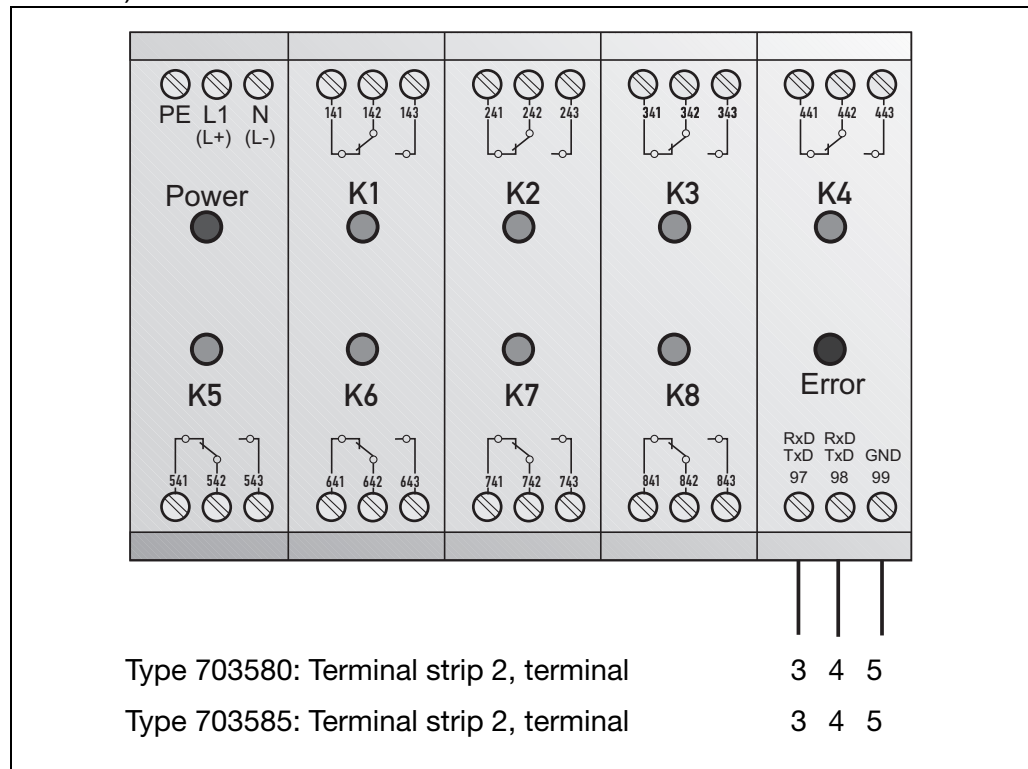

Configuring the module

- * Activate the relay module via the setup program
Edit → Settings only via setup → Expanded configuration

This activates the menu *Edit → External relay module*.

- * Configure the module
The functions are related to the relay module, but they also apply to the logic module (Off = 0 V; On = 12 V).



If the setup plug is connected to the profile controller, the module will not be operated and the outputs are in idle position (logic outputs: 0 V).

14 Accessories

14.2 Setup program with commissioning software

Setup program A setup program for Windows® NT4.0/2000/XP/Vista/7 (32/64 bit) is available for easy configuration of the profile controller.

Hardware requirements:

- 512 Mbyte RAM
- 50 Mbyte available on hard disk
- CD-ROM drive
- 1 free serial interface or USB interface

The program shows the current configuration as a list in the background. The corresponding entry template is called up by double-clicking on the list, or via the menus.

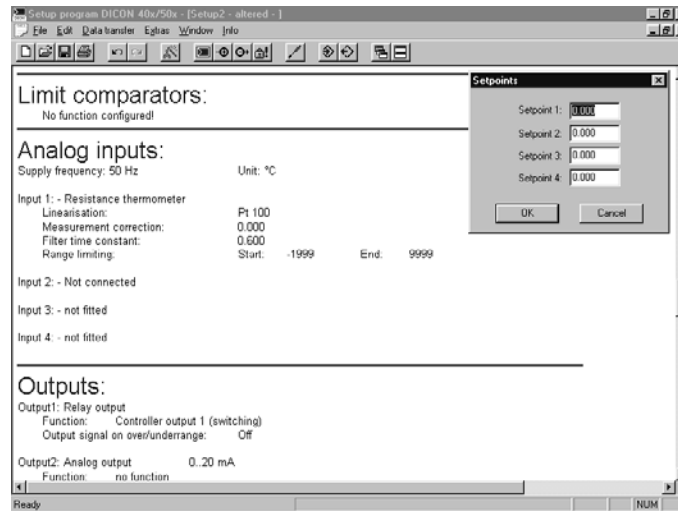

Some functions of the profile controller can only be configured via the setup program:

- Customized linearisation (input of a linearisation table)
- Display brightness of display 3
- Switching off code request (expanded configuration)
- Configuring relay module
- Modifying passwords
- Profile program selection only via one logic input
- Profile program table (any profile program with corresponding start times and conditions can be allocated to 10 program positions, and can then be run through in sequence).
- System states
- Controller active in basic status

Commissioning software The commissioning software is a part of the setup program and is available for adapting the controller to the control loop, optimally and conveniently.

Different process variables (e.g. setpoint, process value, control deviation, signals from the controller outputs) can be displayed graphically. The controller parameters can be altered and transferred to the profile controller via the setup/RS422/485 interfaces.

Data recording is limited to 48 hours.

15.1 Technical data

Thermocouple input

Designation	Range ¹	Meas. accuracy	Ambient temperature error
Fe-Con L	-200 — +900°C	≤0.25%	100 ppm per °C
Fe-Con J EN 60 584	-200 — +1200°C	≤0.25%	100 ppm per °C
Cu-Con U	-200 — +600°C	≤0.25%	100 ppm per °C
Cu-Con T EN 60 584	-200 — +400°C	≤0.25%	100 ppm per °C
NiCr-Ni K EN 60 584	-200 — +1372°C	≤0.25%	100 ppm per °C
NiCr-Con E	-200 — +910°C	≤0.25%	100 ppm per °C
NiCrSi-NiSi N EN 60 584	-100 — +1300°C	≤0.25%	100 ppm per °C
Pt10Rh-Pt S EN 60 584	-50 — +1768°C	≤0.25%	100 ppm per °C
Pt13Rh-Pt R EN 60 584	-50 — +1768°C	≤0.25%	100 ppm per °C
Pt30Rh-Pt6Rh B EN 60 584	0 — 1820°C	≤0.25% ²	100 ppm per °C
W5Re-W26Re	0 — 2320°C	≤0.25%	100 ppm per °C
W3Re-W25Re	0 — 2400°C	≤0.25%	100 ppm per °C
Cold junction	Pt100 internal , external or constant		

1. The specifications refer to an ambient temperature of 20°C.

2. within range 300 — 1820°C

Resistance thermometer input

Designation	Connection type	Range	Meas. accuracy	Ambient temperature error
Pt100 EN 60 751	2-wire/3-wire	-200 — +850°C	≤0.05%	50 ppm per °C
Pt 50,500, 1000 EN 60 751	2-wire/3-wire	-200 — +850°C	≤0.1%	50 ppm per °C
Cu50	2-wire/3-wire	-50 — +200°C	≤0.1%	50 ppm per °C
Ni100 DIN 43760	2-wire/3-wire	-60 — +250°C	≤0.05%	50 ppm per °C
KTY21-6	2-wire	-50 — +150°C	≤1.0%	50 ppm per °C
PtK9	2-wire	lithium-chloride sensor		
Sensor lead resistance	max. 30Ω per conductor in 2-wire/3-wire circuit			
Measuring current	250μA			
Lead compensation	not required for 3-wire circuit. For 2-wire circuit, lead compensation can be provided in the software by measurement correction.			

Standard signal input

Designation	Range	Meas. accuracy	Ambient temperature error
Voltage	0 — 10V, input resistance $R_E > 100k\Omega$	≤0.05%	100 ppm per °C
	-10 to +10V, input resistance $R_E > 100k\Omega$	≤0.05%	100 ppm per °C
	-1 to + 1V, input resistance $R_E > 100k\Omega$	≤0.05%	100 ppm per °C
	0 — 1V, input resistance $R_E > 100k\Omega$	≤0.05%	100 ppm per °C
	0 — 100mV, input resistance $R_E > 100k\Omega$	≤0.05%	100 ppm per °C
	-100 to +100mV, input resistance $R_E > 100k\Omega$	≤0.05%	100 ppm per °C
Current	4 — 20mA, voltage drop ≤ 1V	≤0.1%	100 ppm per °C
	0 — 20mA, voltage drop ≤ 1V	≤0.1%	100 ppm per °C
Potentiometer	min. 100Ω, max. 10kΩ		

Measurement circuit monitoring¹

Transducer	Over/underrange	Probe/lead short-circuit ¹	Probe/lead break
Thermocouple	•	-	•
Resistance thermometer	•	•	•
Voltage	2 — 10V	•	•
	0 — 10V	•	-
Current	4 — 20mA	•	•
	0 — 20mA	•	-

• = recognised - = not recognised

1. In the event of an error, the outputs move to defined states (configurable).

■ Standard version

15 Appendix

Outputs

Relay contact rating contact life contact protection circuit	changeover contact 3A at 250 VAC resistive load 150 000 operations at rated load 56Ω/15nF between common-n.o. make/common-n.c. break		
Logic current limiting	0/5V 20mA	or	0/22V 30mA
Solid-state relay contact rating	1A at 230V		
Voltage output signals load resistance	-10 to +10V / 0 – 10V / 2 – 10V R _{load} 500Ω min.		
Current output signals load resistance	-20 to +20mA / 0 – 20mA / 4 – 20mA R _{load} 450Ω max.		
Supply for 2-wire transmitter voltage current	22V 30mA		

Controller

Controller type	single-setpoint controller, double-setpoint controller, modulating controller, proportional controller, proportional controller with integral actuator driver
Controller structures	P/PD/PI/PID/I
A/D converter	resolution better than 15 bit
Sampling time	210msec

Electrical data

Supply (switched mode power supply)	110 – 240V AC +10/-15% 48 – 63Hz 20 – 30V AC/DC, 48 – 63Hz
Test voltages (type test)	to EN 61010, Part 1 overvoltage category II, pollution degree 2
Power consumption	24VA max. for Type 703580 14VA max. for Type 703585
Data backup	EEPROM
Electrical connection	at the rear via screw terminals, conductor cross-section up to 2.5mm ² and core-end sleeve (length: 10mm)
Electromagnetic compatibility Interference emission Immunity to interference	EN 61326-1 Class A - only for industrial use - Industrial requirements
Safety standards	to EN 60730-1 for Type 703580 to EN 61010-1 for Type 703585

Housing

Housing type	plastic housing for panel-mounting (indoor use) acc. to IEC 61554		
Type	703585/1...	703585/2...	703580/0...
Bezel in mm	48 x 96 (portrait)	96 x 48 (landscape)	96 x 96
Depth behind panel in mm	130	130	130
Panel cut-out in mm	45 ^{+0.6} x 92 ^{+0.8}	92 ^{+0.8} x 45 ^{+0.6}	92 ^{+0.8} x 92 ^{+0.8}
Ambient/storage temperature range	-5 to 55°C / -40 to +70°C		
Climatic conditions	rel. humidity not exceeding 95% annual mean, no condensation		
Site altitude	up to 2000 m above sea level		
Operating position	unrestricted		
Protection	acc. to EN 60529, front IP65, rear IP20		
Weight (fully fitted)	approx. 420g	approx. 420g	approx. 730g

■ Standard version

Approvals/marks of conformity

Mark of conformity	Testing laboratory	Certificates/certification numbers	Test basis	valid for
DIN	Deutsche Industrie Norm	Registernummer TR1117	DIN EN 14 597	DICON 501
GL - Hardware GL - Software	Germanischer Lloyd	Certificate No. 15 694-00 HH	GL-Baumusterprüfung Kategorie C, EMC1	DICON 501
c UL us	Underwriters Laboratories	E 201387	UL 61010-1 CAN/CSA-C22.2 No.61010-1	DICON 401/501

15 Appendix

15.2 Alarm messages and display priorities

Priority	Display		Possible error/ notes	Assignment	Error handling check/repair/replacement	
	Matrix	7-segment				
high	<pre> ████████████████ +LEDs </pre>	<pre> 8888. 8888. (blinks) </pre>	watchdog or power-on will trigger initialisation (reset)	controller	replace controller when initialisation is longer than 5sec	
	(no display)	(no display)	<ul style="list-style-type: none"> - logic function "All displays off" is configured and active - controller faulty - supply faulty 	<ul style="list-style-type: none"> - no error - controller - supply 	<ul style="list-style-type: none"> - open logic input - replace controller - check supply 	
	<pre> BREAK E1 ... BREAK E4 </pre>	<pre> 9999. (blinks) or (*) </pre>	<ul style="list-style-type: none"> - probe/lead break of resistance thermometer (connection 1.9, 1.11, 1.4, 1.8, 2.10, 2.12, 3.20, 3.12) or standard-signal input - probe/lead short-circuit at standard-signal input - overrange at standard-signal input - underrange at standard-signal input 	external signal generator	<ul style="list-style-type: none"> - check probe for break or short-circuit - check probe connection and terminals - check lead 	
	<pre> ORANGE 1 ... ORANGE 4 </pre>	<pre> 9999. (blinks) or (*) </pre>	<ul style="list-style-type: none"> - overrange of resistance thermometer and thermocouple input - probe/lead break of thermocouple input 	external signal generator	<ul style="list-style-type: none"> - is the medium to be measured within the measuring range (too hot - too cold?) - check probe for break or short-circuit - check probe connection and terminals - check lead 	
	<pre> URANGE 1 ... URANGE 4 </pre>	<pre> - 1999. (blinks) or (*) </pre>	<ul style="list-style-type: none"> - underrange of resistance thermometer and thermocouple input - probe/lead short-circuit of resistance thermometer - probe/lead break of resistance thermometer 1.10, 1.7, 2.11, 3.11 			
	<pre> ORANGEM1 ORANGEM2 URANGEM1 URANGEM2 </pre>	(*)	overrange (maths module) (calculation result > range end)			
	<pre> MATH1 ERR MATH2 ERR </pre>	(*)	mathematical error (violation of mathematical rules; impermissible values)	controller	check maths formulae	
	<pre> LOG1 ERR LOG2 ERR </pre>	(*)	logic error (violation of mathematical rules)	controller	check logic formulae	
	<pre> ERS ERR </pre>	(*)	error on relay module	-	-	
	<pre> BUSERROR </pre>	(*)	no communication	periphery	check periphery ¹	
	<pre> SETCLOCK </pre>	(*)	buffer battery empty	controller	set real-time clock ¹	
	<pre> SYS ERR </pre>	(*)	buffer battery empty	controller	restart program ¹	
	<pre> MEM FULL </pre>	(*)	program memory is full	controller	delete programs ¹	
	<pre> NO PGM </pre>	(*)	program is not available	controller	create program ¹	
	low	* display according to configuration 1. can be acknowledged (continued on next page)				

Priority	Display		Possible error/ notes	Assignment	Error handling check/repair/replacement
	Matrix	7-segment			
high 	(Text) ... (Text)	()*	text (logic input 1) ... text display (logic input 8)	-	-
	(Text) ... (Text)	()*	text display (limit comparator 1) ... text display (limit comparator 8)	-	-
	(Text)	()*	text display (logic 1)	-	-
	(Text)	()*	text display (logic 2)	-	-
	SOACTIVE	()*	self-optimisation has been activated	-	-
	---- ()*	measurement input not available or not configured	controller	- configure measurement input - retrofit input card
	low	(display according to configuration)		-	-
* display according to configuration					



Alarm messages with acknowledgement

On pressing the **ENTER** key, the message disappears.

15 Appendix

Table: Assignment of the measurement inputs/response of the outputs in the event of an error (to be filled in by the user)

No.	Measurement input			Response of the outputs in the event of error					
	Transducer	Measuring range	Measurement site	Output 1	Output 2	Output 3	Output 4	Output 5	Output 6
1									
2									
3									
4									
Example:									
1	Pt100	20—500 °C	Machinery room boiler temperature 1	Output 100%		Limit comparator off			

15.3 Character set for matrix display

The special characters for text entry in the setup program are shown here. They are entered from the keys using the key combination Alt + XXX.

0	32	64	@	96	`	128	Ç	160	á	192	224	α
1	33	65	A	97	a	129	ü	161	í	193	225	β
2	34	66	B	98	b	130	é	162	ó	194	226	Γ
3	35	67	C	99	c	131	â	163	ú	195	227	Π
4	36	68	D	100	d	132	ä	164	ñ	196	228	Σ
5	37	69	E	101	e	133	à	165	Ñ	197	229	σ
6	38	70	F	102	f	134	á	166		198	230	μ
7	39	71	G	103	g	135	ç	167		199	231	γ
8	40	72	H	104	h	136	ê	168	ı	200	232	φ
9	41	73	I	105	i	137	ë	169		201	233	θ
10	42	74	J	106	j	138	è	170		202	234	Ω
11	43	75	K	107	k	139	ï	171		203	235	δ
12	44	76	L	108	l	140	î	172		204	236	∞
13	45	77	M	109	m	141	ì	173		205	237	∅
14	46	78	N	110	n	142	Ä	174		206	238	€
15	47	79	O	111	o	143	Å	175		207	239	∩
16	48	80	P	112	p	144	É	176		208	240	
17	49	81	Q	113	q	145	æ	177		209	241	
18	50	82	R	114	r	146	Æ	178		210	242	
19	51	83	S	115	s	147	ô	179		211	243	
20	52	84	T	116	t	148	ö	180		212	244	
21	53	85	U	117	u	149	ò	181		213	245	
22	54	86	V	118	v	150	û	182		214	246	
23	55	87	W	119	w	151	ù	183		215	247	
24	56	88	X	120	x	152	ÿ	184		216	248	°
25	57	89	Y	121	y	153	Ö	185		217	249	·
26	58	90	Z	122	z	154	Ü	186		218	250	
27	59	91	[123	{	155	¢	187		219	251	
28	60	92	\	124		156	£	188		220	252	
29	61	93]	125	}	157	¥	189		221	253	
30	62	94	^	126	~	158		190		222	254	
31	63	95	_	127		159		191		223	255	

200 — 210 reserved for bar graph display

15 Appendix

15.4 Instrument features (configuration level 2)

The software version and the hardware features of the profile controller are shown here.

CONF 2

	Parameters	Value/selection	Description
Version	→VERSION	50.0X.0X	version number
VDN number	→VDN NO.	STANDARD XXX.XXXX	standard version VDN number (modification of standard version)
Analogue input 3	→IN3	NO	not available
Analogue input 4	→IN4	YES	available universal input
Analogue inp. 1 10V	→IN1 10V	NO	not available
Analogue inp. 2 10V	→IN2 10V	YES	available
Analogue inp. 3 10V	→IN3 10V		voltage input
Analogue inp. 4 10V	→IN4 10V		-10/0/2 – 10V
Slot 1	→OUTPUT1	NO	not available
Slot 2	→OUTPUT2	RELAY	relay
Slot 3	→OUTPUT3	SSRELAY	solid-state relay
Slot 4	→OUTPUT4	ANOUTPUT	analogue output
Slot 5	→OUTPUT5	LOGIC 5V	logic output 5V
Slot 6	→OUTPUT6	OUTP 22V LOGIN	logic output 22V or voltage output for 2-wire transmitter two logic inputs
Setup interface	SETUP	NO YES	not connected connected
Interface	INTERFCE	NO RS422/485 PROFIBUS	not available RS 422/485 PROFIBUS-DP
Data buffering	BUFFER	CHARGED EMPTY	charged discharged
Mathematics	MATHLOG	NO YES	not available available

15.5 Notes for instruments with Germanischer Lloyd (GL) approval

The information below is intended to supplement or replace the details that have already been given.

15.5.1 Technical data

Ambient conditions according to application category C for enclosed areas

Temperature	-5 to 55°C
Relative humidity	≤100% r. h.
Vibration	≤0.7g

Electromagnetic compatibility

The electromagnetic compatibility corresponds to the GL guidelines for type examinations (10.97).

15.5.2 Alarm messages

⇒ Section 15.2

15.5.3 Inhibits

All levels are inhibited by codes. Alterations, whether accidental or deliberate, cannot be made easily. The operating level is not inhibited by a code. In this case, it is possible to lock the entire keypad via a logic contact (e.g. key-switch).

⇒ Section 5.3

15.5.4 Manual mode

The user can pause the program by pressing the  key. The program continues when the key is pressed again.

The output (control) cannot be influenced directly.

In the event of an instrument failure, manual operation is no longer possible.

15.5.5 Additional notes



The instrument has to be sent back to the main factory for servicing.

In accordance with the regulations of the Germanischer Lloyd, certain applications require the availability of a reserve instrument.

15 Appendix



The instrument can only be used with restrictions on the bridge, since a continuous dimming of the display brightness is not possible!



it is recommended that a print-out of the setup program be kept on site, together with the technical documentation for the controller (can be requested, if necessary).

A

Accessories *10, 85*
Action *49*
Alarm messages *90*
Alteration, temporary *40*
Altering
 segment time of current segment *40*
 setpoint in current segment *40*
 setpoint in subsequent segment *40*
Analogue input *9, 94*
 configuring *80*
Approvals *9*

B

Basic status *24–25, 27*
Basic type extension *9*
Block structure *7*

C

Card
 identifying *79*
 retrofitting *79*
Character set *93*
Clock, setting of *42*
Code request *25*
Conditions
 climatic *11*
Configuration level *1 25, 45*
Connection diagrams *16*
Continue *60*
 at deviation *60*
Control direction *47*
Controller *47*
Controller chassis, removal of *14*
Controller type *47*

D

Data buffering *94*
Data format *73*
Dead band *48*
Decimal point
 shifting *26*
Delay time *33*
Description *7*
Dimensions *11*
Display *67*
Display and keys *23*
Display switching *32*
 automatic *67*

E

Edge-to-edge mounting *13*
Edit segment *36*

End value *58*
External relay module *85*
External setpoint with correction *30*

F

Filter time constant *54*
Fitting into position *13*
Formula input *64*
Front panel, cleaning of *13*
Function control *60*
Fuzzy control *48, 77*

H

Humidity control *63*

I

Installation *11*
Installation notes *15*
Instrument features *94*
Instrument version *9*
Interface *9, 31, 73, 83, 94*
Isolation *21*

K

Key combination *8*
Key designation *23*

L

Language for instrument texts *67*
Levels and menus *26*
Limit comparator *49, 70*
 absolute *51*
 relative *51*
Limit comparator functions *49*
Limit value *50*
Location *11*
Logic *70*
Logic formula *66*
Logic function *70*
 combined *71*
Logic input *70*

M

Manual output *48*
Mathematics formula *64*
Maths and logic module *9, 62, 94*
Measurement circuit monitoring *87*

N

Note signs *8*

16 Index

O

Operating contact 28, 70
Operating level 25, 28, 41
Operating mode 24, 30
 automatic 24, 29
 manual 24, 28, 48
Operation 23
Optimisation 76
Output 9, 57

P

Parameter level 25
Parameter set 28
Parameter set number 41
Presentation 8
Procedure 75
Process variables 41
PROFIBUS-DP 84
Profile
 shifting 30
Profile controller 59
Program
 aborting 60
 creating 36
 deleting 37
 starting 29, 33
Program delay time
 starting 33
Program editor 25, 35
Program end signal 70
Program number 33
Program start 25, 33, 59
Program stop 24
Program times 41
Protocol type 73
Pulse function 50

R

Range end 54, 62
Range start 62
Ratio control 63
Real-time clock 33, 41
Recalibration
 customized 55
Repeat cycles 39
Response time
 minimum 73
Restart
 after power failure 59

S

Segment
 copying 37–38
 deleting 37, 39

 editing 37
 free 41
 inserting 37–38
Segment change 29
Segment setpoint
 altering in current program 29
Segment time, residual 33
Selection 27
Self-optimisation 24, 48, 75
 starting 75
Setpoint input 59
Setpoint limits 48
Setpoint switching 31
Setpoints 41
 altering 30
Setup program 86
Slot 94
 assigning 81
Standstill 24, 60
Start day 33
Start segment 33
Start time 33
Supply 9
Switching action 71
Switching differential 50
Switch-on delay 50
System state 28, 41

T

Technical data 87
Time 62
Time input 27
Time/gradient programming 59
Time-out 25, 67
Tolerance band signal 70
Type designation 9
Typographical conventions 8

U

Unit address 73

V

Value input 26
Variable a 62
Variable b 62
Version 94

W

Warning signs 8

Z

Zero point 58



JUMO GmbH & Co. KG

Street address:
Moritz-Juchheim-Straße 1
36039 Fulda, Germany
Delivery address:
Mackenrodtstraße 14
36039 Fulda, Germany
Postal address:
36035 Fulda, Germany
Phone: +49 661 6003-0
Fax: +49 661 6003-607
E-mail: mail@jumo.net
Internet: www.jumo.net

JUMO Instrument Co. Ltd.

JUMO House
Temple Bank, Riverway
Harlow, Essex CM20 2DY, UK
Phone: +44 1279 635533
Fax: +44 1279 635262
E-mail: sales@jumo.co.uk
Internet: www.jumo.co.uk

JUMO Process Control, Inc.

6733 Myers Road
East Syracuse, NY 13057, USA
Phone: 315-437-5866
1-800-554-5866
Fax: 315-437-5860
E-mail: info.us@jumo.net
Internet: www.jumousa.com