

**JUMO**



## **JUMO** DICON 1001

Universal Profile Controller

B 70.3565  
Operating Manual

2.97 / 00331907

# 5.5 Overview of the key functions

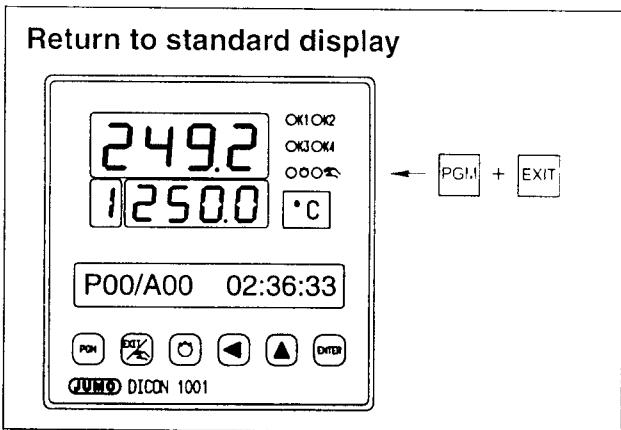
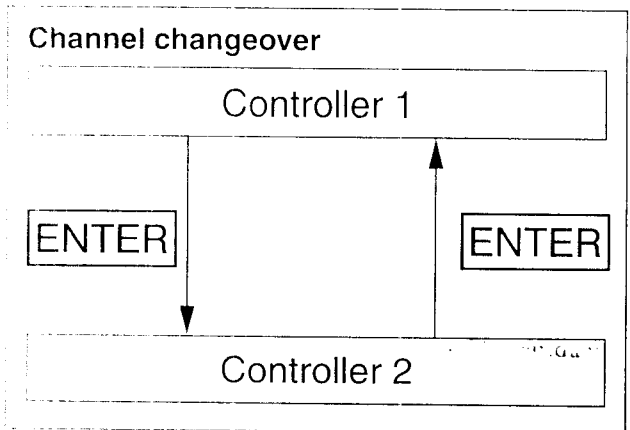
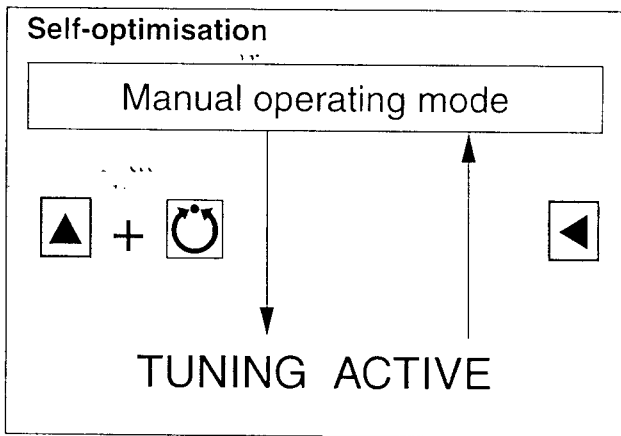
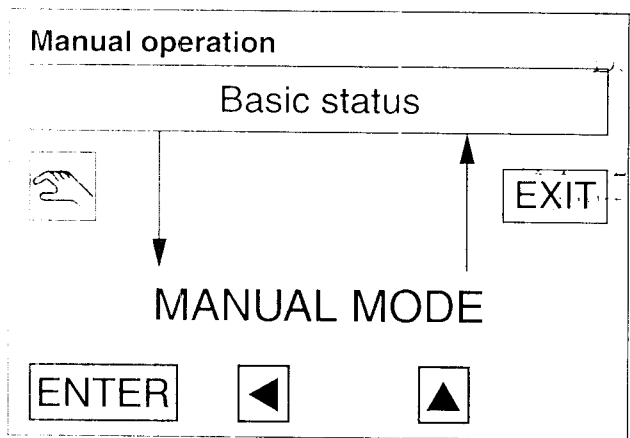
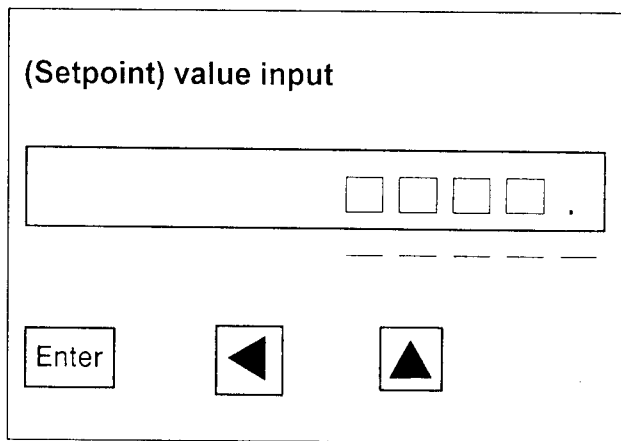
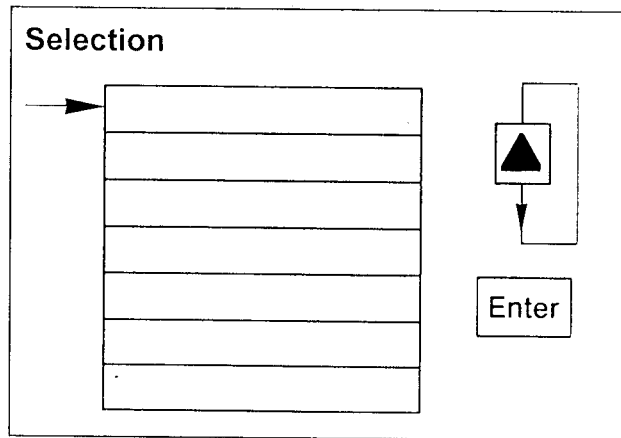
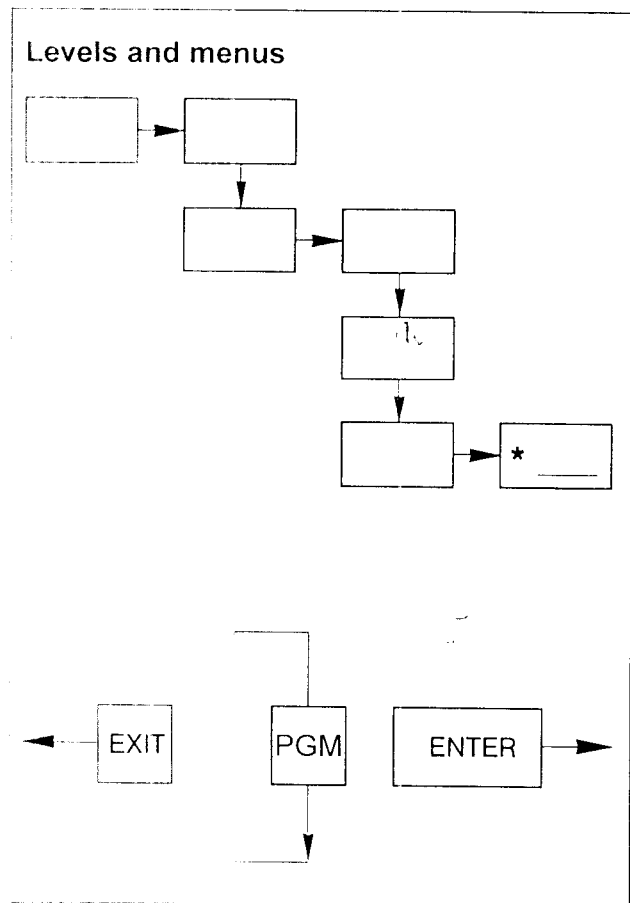

**FOLD-OUT**



Please read this Manual before starting up the instrument. Keep this Manual in a place which is at any time accessible to all users.

Please assist us to improve this Manual where necessary.

We are always grateful for your suggestions.

Phone:

Germany (0661) 6003-727  
abroad (int. +49) 661 6003-0

Fax:

Germany (0661) 6003-508  
abroad (int. +49) 661 6003-607



All necessary settings and, where appropriate, alterations inside the unit are described in this Operating Manual.

If any problems should arise during start-up do not carry out any manipulations on the unit which are not permitted.

This endangers your rights under the warranty!

Please contact the nearest JUMO office or the main factory.



When returning chassis, modules or components the rules of EN 100 015 "Protection of electrostatically endangered components" have to be observed.

Use only the appropriate ESD packaging material for transport.

Please note that we cannot be held liable for any damage caused by ESD (electrostatic discharges).

# Alterations to B 70.3560 and B 70.3565

---

## Real-time clock (only in DICON 1001)



The settings for the real-time clock can be found in the operating level.

## Parameter set number (only in DICON 1001)

B 70.3565: Pages 29, 37



The numbering of the parameter sets starts at 1.

## C-level control

B 70.3560: Pages 92, 93, 94

B 70.3565: Pages 108, 109, 110

## C-level calculation

$$E = 0.0992 \cdot T \cdot (-\lg(P_{\text{CO}}) + 1.995 + 0.15 \cdot C_p + \lg(C_p)) \cdot \text{mV}/^\circ\text{C} + 816.1 \text{ mV}$$

- E - e.m.f. of the zirconium dioxide sensor
- T - sensor temperature in °C
- P<sub>CO</sub> - partial pressure of CO in % by volume
- C<sub>p</sub> - carbon level

## Correction factor

The correction factor is a C-level value which is obtained by reference measurement.  
Value range: -1999 to +9999; factory setting: 1

## Flushing time

Value range: 0 to 600min; factory setting: 0min

## Recovery time

Value range: 0 to 600min; factory setting: 0min

---

# CONTENTS

---

	<b>Page</b>
<b>1 INTRODUCTION</b>	<b>7</b>
1.1 Description .....	7
1.2 Block structure .....	8
1.3 Profile controller structure .....	9
1.4 Arrangement of this Manual .....	10
1.5 Typographical conventions .....	12
1.5.1 Warning signs .....	12
1.5.2 Note signs .....	12
1.5.3 Presentation .....	13
<b>2 IDENTIFYING THE INSTRUMENT VERSION</b>	<b>14</b>
2.1. Type designation .....	14
2.2 Accessories .....	15
<b>3 INSTALLATION</b>	<b>16</b>
3.1 Location and climatic conditions .....	16
3.2 Fitting in position .....	16
3.3 Dimensions .....	16
3.4 Close-up mounting .....	17
3.5 Cleaning the front panel .....	17
3.6 Affixing the unit label .....	17
<b>4 ELECTRICAL CONNECTION</b>	<b>18</b>
4.1 Installation notes .....	18
4.2 Isolation .....	19
4.3 Connection diagram .....	20
4.4 Earth (ground) connection .....	22
<b>5 PREPARATION</b>	<b>23</b>
5.1 Displays and keys on the front panel .....	23
5.2 Operating modes and states .....	24
5.3 Principle of operation .....	25
5.4 Level inhibit and access code .....	28
<b>6 OPERATION</b>	<b>29</b>
6.1 Manual operation .....	29
6.2 Auto-manual operation .....	30
6.3 Profile start .....	30
6.4 Fast forward .....	30
6.5 Self-optimisation .....	31
6.6 Channel changeover .....	32
<b>7 PROFILE START</b>	<b>33</b>

# CONTENTS

---

	<b>Page</b>
<b>8 PROFILE PROGRAM EDITOR</b>	<b>35</b>
8.1 General notes .....	35
8.2 Overview .....	36
8.3 Creating profile programs .....	39
8.4 Editing segments .....	39
8.5 Inserting segments .....	40
8.6 Copying segments .....	40
8.7 Deleting segments .....	41
8.8 Programming repeat cycles .....	41
8.9 Temporary alterations .....	42
<b>9 OPERATING LEVEL</b>	<b>43</b>
9.1 Overview .....	43
9.2 Setpoints .....	44
9.3 Process variables .....	45
9.4 Profile times .....	46
9.5 Memory capacity .....	47
9.6 Self-optimisation .....	48
9.7 Automatic channel scrolling .....	49
9.8 Channel changeover .....	50
<b>10 PARAMETER LEVEL</b>	<b>51</b>
10.1 Overview .....	51
10.2 Parameter set .....	52
<b>11 CONFIGURATION LEVEL C1</b>	<b>53</b>
11.1 Overview .....	53
11.2 Controllers .....	54
11.3 Limit comparators .....	56
11.4 Inputs .....	58
11.5 Outputs .....	63
11.6 External relay module .....	66
11.7 Special functions .....	68
<b>12 CONFIGURATION LEVEL C2</b>	<b>74</b>
12.1 Overview .....	74
12.2 Display .....	75
12.3 Logic inputs .....	78
12.4 Cascade controller .....	80
12.5 Customized recalibration .....	81
12.6 Time-out .....	84
12.7 Unit .....	85
12.8 Supply frequency .....	86
12.9 Real time clock .....	87
12.10 Interface .....	88
<b>13 CONFIGURATION LEVEL C3</b>	<b>90</b>
13.1 Overview .....	90

---

# CONTENTS

	<b>Page</b>
<b>14 BINARY FUNCTIONS</b>	<b>92</b>
14.1 Combined binary functions .....	92
14.2 Other functions .....	94
<b>15 OPTIMISATION</b>	<b>95</b>
15.1 Optimisation method after Ziegler and Nichols .....	96
15.2 Self-optimisation .....	98
15.3 Fuzzy parameters .....	99
15.4 Checking the optimisation .....	100
<b>16 EXTRA CODES AND ACCESSORIES</b>	<b>101</b>
16.1 External relay module ER8 .....	101
16.2 RS422/RS485 interface .....	102
16.3 Maths and logics module .....	103
16.3.1 Math formula .....	103
16.3.2 Logic formula .....	106
16.4 Setup program .....	107
16.5 C-level control .....	108
16.5.1 C-level calculation .....	108
16.5.2 Control sequence .....	108
16.5.3 C-level menu .....	108
16.5.4 Notes .....	111
<b>17 CONFIGURATION EXAMPLES</b>	<b>112</b>
17.1 Controller with parameter set switching depending on setpoint .....	112
17.2 Cascade controller .....	113
17.3 Trim cascade controller .....	115
17.4 Difference controller .....	117
17.5 Ratio controller .....	119
17.6 Humidity controller .....	121
17.7 Proportional controller with integral driver for motorised actuators .....	123
17.8 Controller with additive disturbance compensation .....	125
17.9 Controller with multiplying disturbance compensation .....	127
17.10 Controller with limit comparator and text display .....	129
17.11 Controller with heater current monitoring .....	131
17.12 Controller with maths module .....	133
17.13 C-level controller .....	134
<b>18 RETROFITTING OF CARDS</b>	<b>137</b>
<b>19 APPENDIX</b>	<b>140</b>
19.1 Technical data .....	140
19.2 Limit comparator functions .....	143
19.3 Alarm messages and indication priorities in the standard display .....	145
19.4 Character set for matrix display .....	147
19.5 Restart after supply failure .....	148

# 1 INTRODUCTION

---

## 1.1 Description

JUMO DICON 1001 is a universal and freely programmable profile controller with one or two channels for different physical control parameters, with a bezel size 96 mm x 96 mm.

The controller has two 4-digit 7-segment displays, one single-digit 7-segment display, switching and status indications, as well as a 16-character matrix display.

Six keys are provided on the front for operation, parameter setting and configuration. The instrument can be used as single and double setpoint controller, as modulating and proportional controller, and also as proportional controller with integral actuator driver.

The two profile channels can each be programmed with 25 profiles of up to 100 segments. The profiles run in synchronism. In addition there are eight operating contacts.

A maths and logics module is available as an extra. The plug-in controller chassis simplifies retrofitting of additional modules. The controller can be integrated into a data network through its serial interface. A set-up program and a profile program editor are available for easy configuration via a PC. The number of outputs can be increased through an external relay module with eight switching outputs.

# 1 INTRODUCTION

## 1.2 Block structure

= extra Code

### Interfaces

- RS485/RS422
- setup interface

### 4 analogue inputs

Input 1 and 2  
Input 3 and 4  
for

- Pt 100
- thermocouples
- standard signals
- potentiometers

Functions:

- process variable
- input values for maths functions
- input values for limit comparators
- output retransmission
- heater current monitoring

### 4 outputs

Output 1,  
Output 3 and 4:

- relay
- solid-state relay
- analogue output

Output 2:

- relay

Functions:

- controller outputs
- limit comparator outputs
- operating contacts
- profile end signal
- tolerance signal
- maths and logics outputs
- value of the analogue inputs
- setpoints
- control deviations

### 5 logic inputs

for floating contacts

Functions:

- auto/manual changeover
- programming inhibit
- profile start/stop
- profile abort
- fast forward
- programme selection
- text display
- ...

### Temperature compensation

- internal CJ Pt 100
- external CJ Pt 100
- fixed

**JUMO DICON 1001**

**Profile controller 2**

**Maths and logics module**

### External relay module

8 relay outputs

Functions:

- controller outputs
- limit comparator outputs
- operating contacts
- logic outputs (logics module)
- tolerance signal
- profile end signal

# 1 INTRODUCTION

## 1.3 Profile controller structure

25 programs with one or two profiles can be created. The profile programs run in synchronism and can consist of up to 100 segments. A total of 500 segments can be programmed. In addition eight operating contacts can be programmed which are assigned to the profiles and also run in synchronism. A profile can be started manually by operating a key (on the instrument or externally) or by programming start conditions. In programming the start conditions the time can be set either by selecting a start delay or by programming a weekday and clock time.

Profiles consist of a series of segments with definable segment setpoints. The individual segment setpoints can be connected either by ramps or by step functions. At each segment the status of the eight operating contacts can be altered. In addition each segment has assigned to it one of four programmable parameter sets as well as an upper and a lower limit (tolerance band) for monitoring the process value.

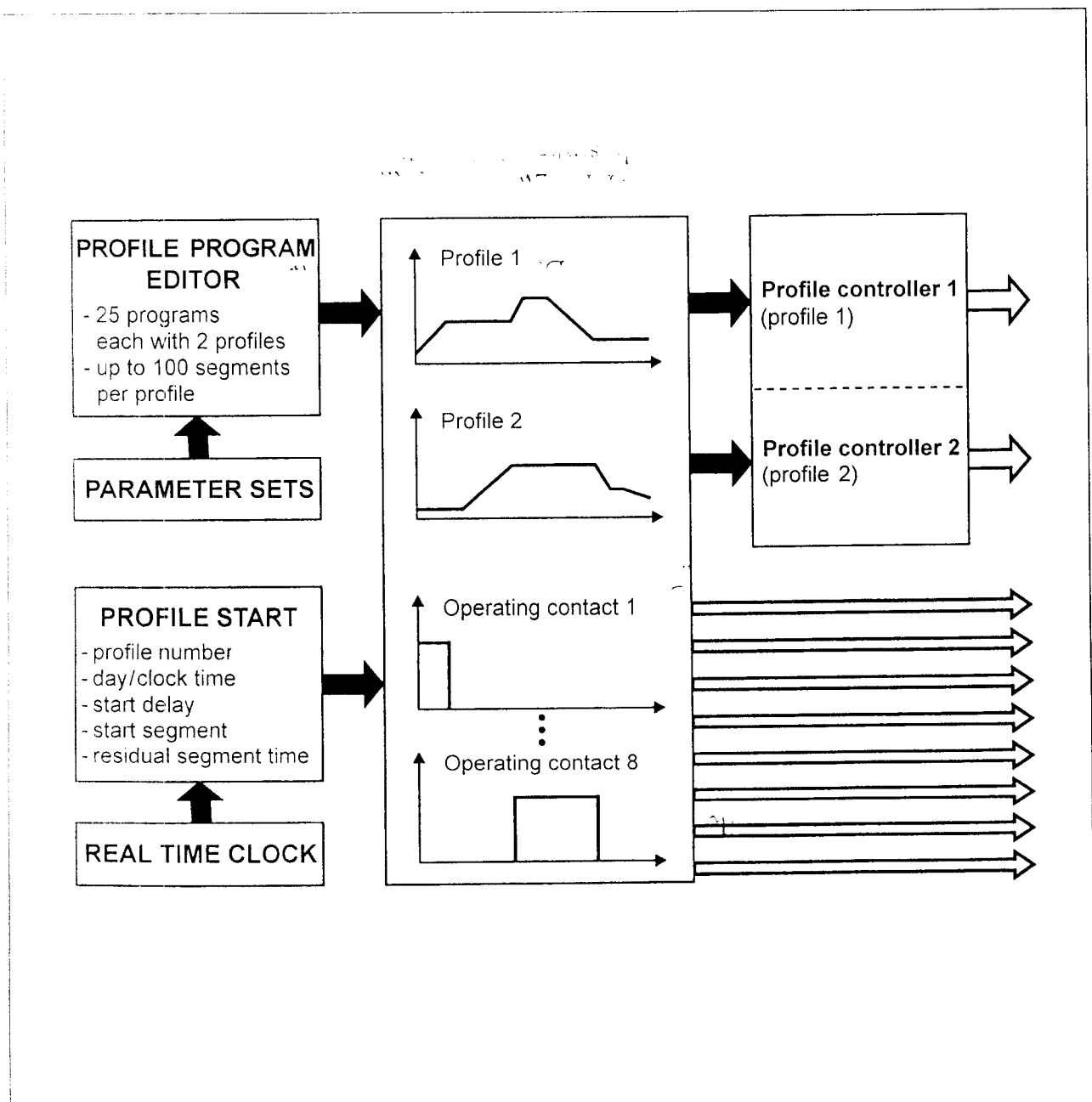

# 1 INTRODUCTION

## 1.4 Arrangement of this Manual

The Manual is divided into individual information blocks (chapters) which are so arranged that the user can follow the individual items step by step.

Step	Chapter	Purpose
1	1 INTRODUCTION	<input type="checkbox"/> To get to know the instrument and its functions! <input type="checkbox"/> To get to know the symbols and forms of presentation
2	2 IDENTIFYING THE INSTRUMENT VERSION	<input type="checkbox"/> To find out the instrument version from the details on the label!
3	3 INSTALLATION	<input type="checkbox"/> To install the instrument correctly in relation to the climatic conditions on site!
4	4 ELECTRICAL CONNECTION	<input type="checkbox"/> To make safe connections to the instrument with due regard to the "installation notes"!
5	5 PREPARATION	<input type="checkbox"/> To get to know the controls and indications on the front panel! <input type="checkbox"/> To understand the principle of operation! <input type="checkbox"/> To obtain an overview of the operating modes, states, levels and menus! <b>This is the most important precondition for the following chapters!</b>
6	6 OPERATION	<input type="checkbox"/> To achieve expertise in all settings and manipulations during operation! <input type="checkbox"/> To be able to activate different operating modes!
7	7 PROFILE START	<input type="checkbox"/> To set start conditions and start time
	8 PROFILE PROGRAM EDITOR	<input type="checkbox"/> To learn to create and edit profile programs!
8	9 OPERATING LEVEL	<input type="checkbox"/> To indicate and alter process parameters.

# 1 INTRODUCTION

Step	Chapter	Purpose
9	10 PARAMETER LEVEL	<input type="checkbox"/> To determine parameter sets for controllers 1 and 2!
10	11 CONFIGURATION LEVEL C1	<input type="checkbox"/> To set controller-specific features!
	12 CONFIGURATION LEVEL C2	<input type="checkbox"/> To set system-specific features!
	13 CONFIGURATION LEVEL C3	<input type="checkbox"/> To identify the extra Codes incorporated in hardware and software!
11	14 LOGIC INPUTS	<input type="checkbox"/> To get to know the functions of the logic inputs!
12	15 OPTIMISATION	<input type="checkbox"/> To adapt the controller to the process loop using self-optimisation!
		<input type="checkbox"/> To get to know the functions of the fuzzy parameters and their settings!
		<input type="checkbox"/> To check the results of optimisation!
13	16 EXTRA CODES AND ACCESSORIES	<input type="checkbox"/> To get to know extra Codes and accessories!
14	17 EXAMPLES OF CONFIGURATION	<input type="checkbox"/> To get to know different controller types and their configuration!
15	18 RETROFITTING MODULES	<input type="checkbox"/> To fit and remove modules safely!
16	19 APPENDIX	<input type="checkbox"/> Technical data
		<input type="checkbox"/> Limit comparator functions
		<input type="checkbox"/> Alarm messages, and indication priorities
		<input type="checkbox"/> Character set
		<input type="checkbox"/> Restart after supply failure

# 1 INTRODUCTION

---

## 1.5 Typographical conventions

### 1.5.1 Warning signs

The signs for **Danger** and **Warning** are used in this Manual under the following conditions:



**Danger** This symbol is used when there may be **danger to personnel** if the instructions are disregarded or not followed accurately.



**Warning** This symbol is used when there may be **damage to equipment or data** if the instructions are disregarded or not followed accurately.



**Warning** This symbol is used when precautions have to be observed in handling components liable to be damaged by electrostatic discharges.

### 1.5.2 Note signs



**Note** This symbol is used if your **special attention** is drawn to a remark.

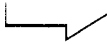

**Reference** This symbol refers to **additional information** in other handbooks, chapters or sections.

abcd<sup>1</sup>

**Footnote** Footnotes are **notes** which refer to certain points in the text. Footnotes consist of 2 parts: the text marking and the footnote text.

The text markings are arranged as continuous raised numbers.

The footnote text (in smaller typeface) is placed at the bottom of the page and starts with a number and a full stop.

\*

**Action** This sign refers to the description of an **action to be performed**.

The **individual steps** are indicated by this asterisk, e.g.

\* Press PGM key

\* Enter with ENTER

# 1 INTRODUCTION

---

## 1.5.3 Presentation



**Keys** Keys are shown in a frame. Both symbols and texts are possible. Where a key has multiple functions (function keys) the text shown corresponds to the function which is currently active.

SETPOINT 100.

**Matrix display** The grey area represents the matrix display showing parameter values, text, messages and notes for operator guidance.

SETPOINT 100.  
-----

**Position** The line marks the position where a value is being input.

1

**Item** This is followed by explanations for drawings and concepts.



**Return/** Key on the PC keyboard to enter an input.  
**ENTER** Press ENTER key on the instrument

# 2 IDENTIFYING THE INSTRUMENT VERSION

## 2.1 Type designation

The label is affixed to the housing. The type designation contains all factory settings such as controller function, inputs and extra Codes.

The Codes under ⑥ are listed in sequence and separated by a comma.

The supply must agree with the voltage indicated on the label.

### ① Controller type

#### Description

- single-setpoint controller with O (break) function (relay de-energised for process above setpoint), controller structure can be configured \_\_\_\_\_ 1 0
- single-setpoint controller with S (make) function (relay de-energised for process below setpoint), controller structure can be configured \_\_\_\_\_ 2 0
- double-setpoint controller, controller structure can be configured \_\_\_\_\_ 3 0
- modulating controller, controller structure can be configured \_\_\_\_\_ 4 0
- proportional controller, controller structure and output signal can be configured \_\_\_\_\_ 5 0
- proportional controller with integral driver for motorised actuators \_\_\_\_\_ 8 0

### ② Input 1 probe type

- resistance thermometer Pt 100 in 3-wire circuit \_\_\_\_\_ 0 0 1
- NiCr-Con E \_\_\_\_\_ 0 3 8
- Cu-Con T \_\_\_\_\_ 0 3 9
- Fe-Con J \_\_\_\_\_ 0 4 0
- Cu-Con U \_\_\_\_\_ 0 4 1
- Fe-Con L \_\_\_\_\_ 0 4 2
- NiCr-Ni K \_\_\_\_\_ 0 4 3
- Pt10Rh-Pt S \_\_\_\_\_ 0 4 4
- Pt13Rh-Pt R \_\_\_\_\_ 0 4 5
- Pt30Rh-Pt6Rh B \_\_\_\_\_ 0 4 6
- NiCrSi-NiSi N \_\_\_\_\_ 0 4 8
- linear input signals
- 0 --- 20 mA \_\_\_\_\_ 0 5 2
- 4 --- 20 mA \_\_\_\_\_ 0 5 3
- 0 --- 1 V \_\_\_\_\_ 0 6 2
- 0 --- 10 V \_\_\_\_\_ 0 6 3
- 0 --- 50 mV \_\_\_\_\_ 0 6 4
- 0 --- 2 V (for C-level controller) \_\_\_\_\_ 0 7 3

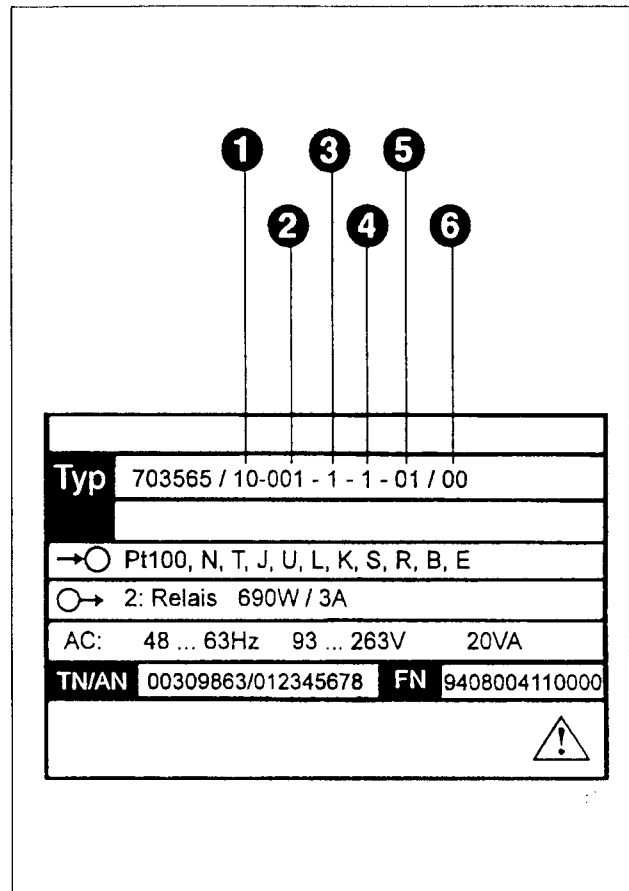

### ③ Output 1 output signal

- relay \_\_\_\_\_ 1
- solid state relay 1 A \_\_\_\_\_ 2
- logic 0/24 V \_\_\_\_\_ 3
- analogue output
- 0 --- 20 mA \_\_\_\_\_ 4
- 4 --- 20 mA \_\_\_\_\_ 5
- 20 / 0 / +20 mA \_\_\_\_\_ 6
- 0 --- 10 V \_\_\_\_\_ 7
- 2 --- 10 V \_\_\_\_\_ 8
- 10 / 0 / +10 V \_\_\_\_\_ 9

Relay output is the normal version for Output 2.

### ④ Operator guidance

- German \_\_\_\_\_ 1
- English \_\_\_\_\_ 2
- French \_\_\_\_\_ 3

## 2 IDENTIFYING THE INSTRUMENT VERSION

### 5 Supply

93 --- 263 V AC 48 — 63 Hz \_\_\_\_\_  
 20 --- 53 V DC/AC 0/48 — 63 Hz \_\_\_\_\_

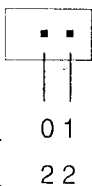

### 2.2 Accessories

External relay module ER8 with eight relays

Supply            93 — 263 V AC  
 Sales No.        70/00325805  
 Supply            20 — 53 V DC/AC  
 Sales No.        70/00325806

Section 16.1

### 6 Extra Codes, hardware

none \_\_\_\_\_ 00  
 analogue inputs 3 + 4 \_\_\_\_\_ 01  
 output 3 \_\_\_\_\_ 3  
 output 4 \_\_\_\_\_ 4  
 relay \_\_\_\_\_ .1  
 solid state relay 1 A \_\_\_\_\_ .2  
 logic 0/24 V \_\_\_\_\_ .3

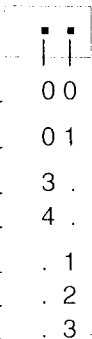

PC interface with TTL/RS232 converter  
 Sales No.        70/00301315

Section 16.4

analogue output  
 0 — 20 mA \_\_\_\_\_ .4  
 4 — 20 mA \_\_\_\_\_ .5  
 -20 / 0 / +20 mA \_\_\_\_\_ .6  
 0 — 10 V \_\_\_\_\_ .7  
 2 — 10 V \_\_\_\_\_ .8  
 -10 / 0 / +10 V \_\_\_\_\_ .9  
 interface RS422, isolated \_\_\_\_\_ 52  
 interface RS485, isolated \_\_\_\_\_ 53  
 Controller meets requirements of  
 Underwriter Laboratories Inc. \_\_\_\_\_ 61  
 Carbon level controller \_\_\_\_\_ 04

Section 16.4

PC profile program editor

### 6 Extra Codes, software

second profile controller \_\_\_\_\_ 02  
 maths and logics module  
 (incl. difference, ratio and  
 psychrometric humidity) \_\_\_\_\_ 03

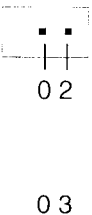

# 3 INSTALLATION

## 3.1 Location and climatic conditions

The instrument location should as far as possible be free from shock and vibration. Electro-magnetic fields, e.g. from motors, transformers etc., should be avoided. The ambient temperature at the instrument location should be between 0 and 50 °C at a relative humidity of not more than 75%.

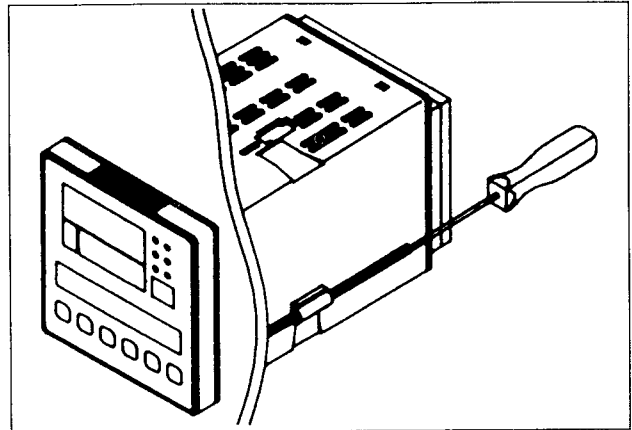

## 3.2 Fitting in position

- \* Attach the blank label supplied to the side of the controller.
- \* Insert the controller from the front into the panel cut-out.
- \* Insert the mounting brackets from behind the panel into the cut-outs at the sides of the housing. The flat sides of the brackets must be against the housing.
- \* Place the brackets against the rear of the panel and tighten them evenly using a screwdriver.

mm	inch	mm	inch
3.5	0.14	91.6	3.61
6	0.24	92.0 <sup>+0.8</sup>	3.62 <sup>+0.03</sup>
12.6	0.50	96	3.78
15	0.59	97.2	3.83
25	1.0	104.2	4.10
28.2	1.11	150	5.91
60	2.4	165	6.50
83.9	3.30		

## 3.3 Dimensions

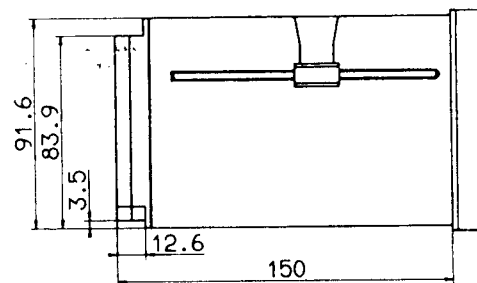
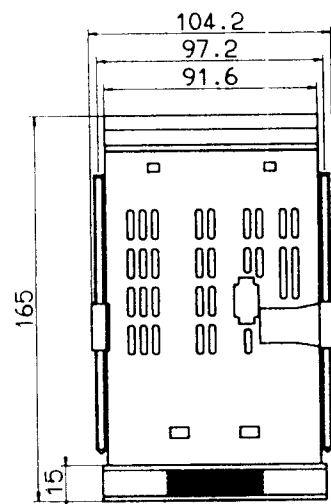
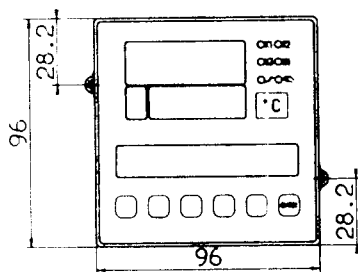

Panel cut-out to DIN 43 700

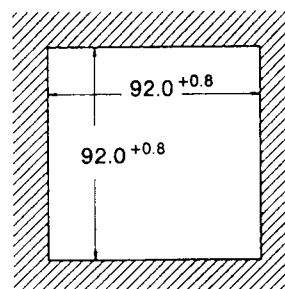

# 3 INSTALLATION

## 3.4 Close-up mounting

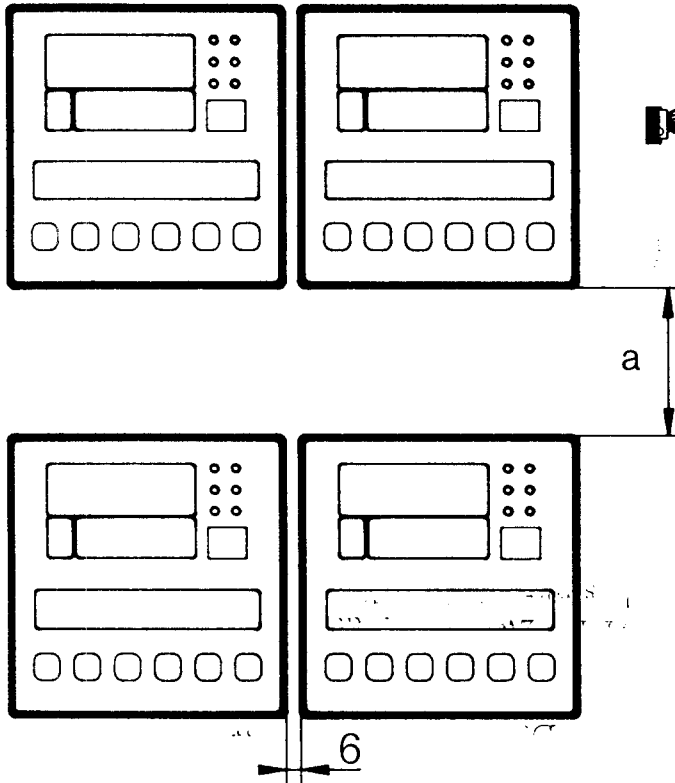

The setup interface is located at the top of the housing.  
 A minimum spacing "a" between two controllers is required to provide access for inserting the PC interface plug.

Minimum spacing	a
with PC interface	60 mm
without PC interface	25 mm

## 3.5 Cleaning the front panel

The front panel can be cleaned with commercially available rinsing and cleaning agents. It has limited resistance to organic solvents (e.g. alcohol, surgical spirit, P1, xylol etc.). Do not use a high-pressure cleaner!

## 3.6 Affixing the unit label

The controller is supplied as standard with a collection of labels with different physical units.

- \* Peel off the unit label from the backing foil and affix it over the printed °C sign.

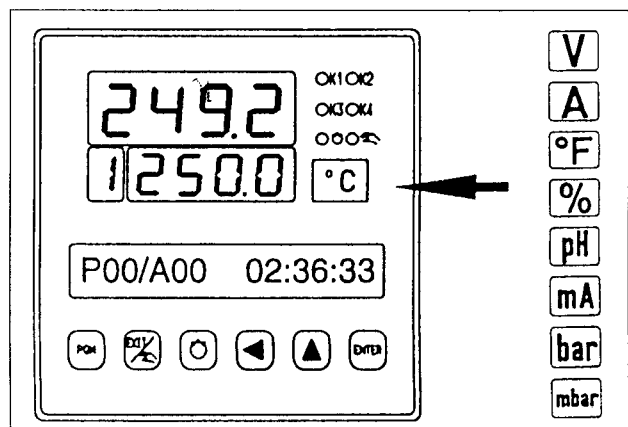

# 4 ELECTRICAL CONNECTION

---

## 4.1 Installation notes

- ┌ The choice of cable, the installation and the electrical connection of the instrument must meet the requirements of VDE 0100 "Regulations on the Installation of Power Circuits with nominal voltages below 1000 V" or the appropriate local regulations.
  - ┌ Work inside the instrument must only be carried out to the extent described and, like the electrical connection, only by suitably qualified personnel.
  - ┌ Isolate the unit on line and neutral from the supply if there may be contact with live parts during work.
  - ┌ A built-in current limiting resistor interrupts the supply circuit in case of a short-circuit. The external fuse of the supply should not be rated above 1 A (slow). The load circuit has to be fused for the maximum relay current in order to prevent welding of the output relay contacts in case of an external short-circuit.
  - ┌ Electromagnetic compatibility conforms to the Standards and Regulations specified under Technical Data.
  - ┌ Input, output and supply lines should be run separately and not parallel to each other.
  - ┌ Sensor and interface lines should be screened and twisted together. Do not run them close to live components or cables. Ground the screen only at one end at the instrument terminal TE.
  - ┌ Ground the instrument at terminal TE to the protective ground conductor. This line should have the same cross-section as the supply lines. Run the ground lines in a star configuration to a common ground point connected to the ground conductor of the supply. Do not loop the ground connections, i.e. do not run them from one instrument to another.
- ┐ Do not connect any further loads to the supply terminals of the instrument.
  - ┐ The instrument is not suitable for installation in hazardous areas.
  - ┐ Apart from unsatisfactory installation, incorrect settings on the controller (setpoint, data at parameter and configuration level, alterations inside the instrument) may interfere with the proper operation of the controlled process or result in damage.

Provision should therefore always be made for safety devices independent of the controller, e.g. overpressure valves or temperature limiters/monitors.

Setting up must be restricted to qualified personnel. Please observe the appropriate safety regulations in this connection. Adaptation (self-optimisation) cannot be expected to handle all possible control loops so that there is theoretically a possibility of setting unstable parameters. The final process value should therefore be checked for its stability.

- ┐ The maximum permitted voltage difference between the inputs of the controller and TE is 30 V AC or 50 V DC.

┐ Section 19.1

┐ Section 4.4

# 4 ELECTRICAL CONNECTION

## 4.2 Isolation

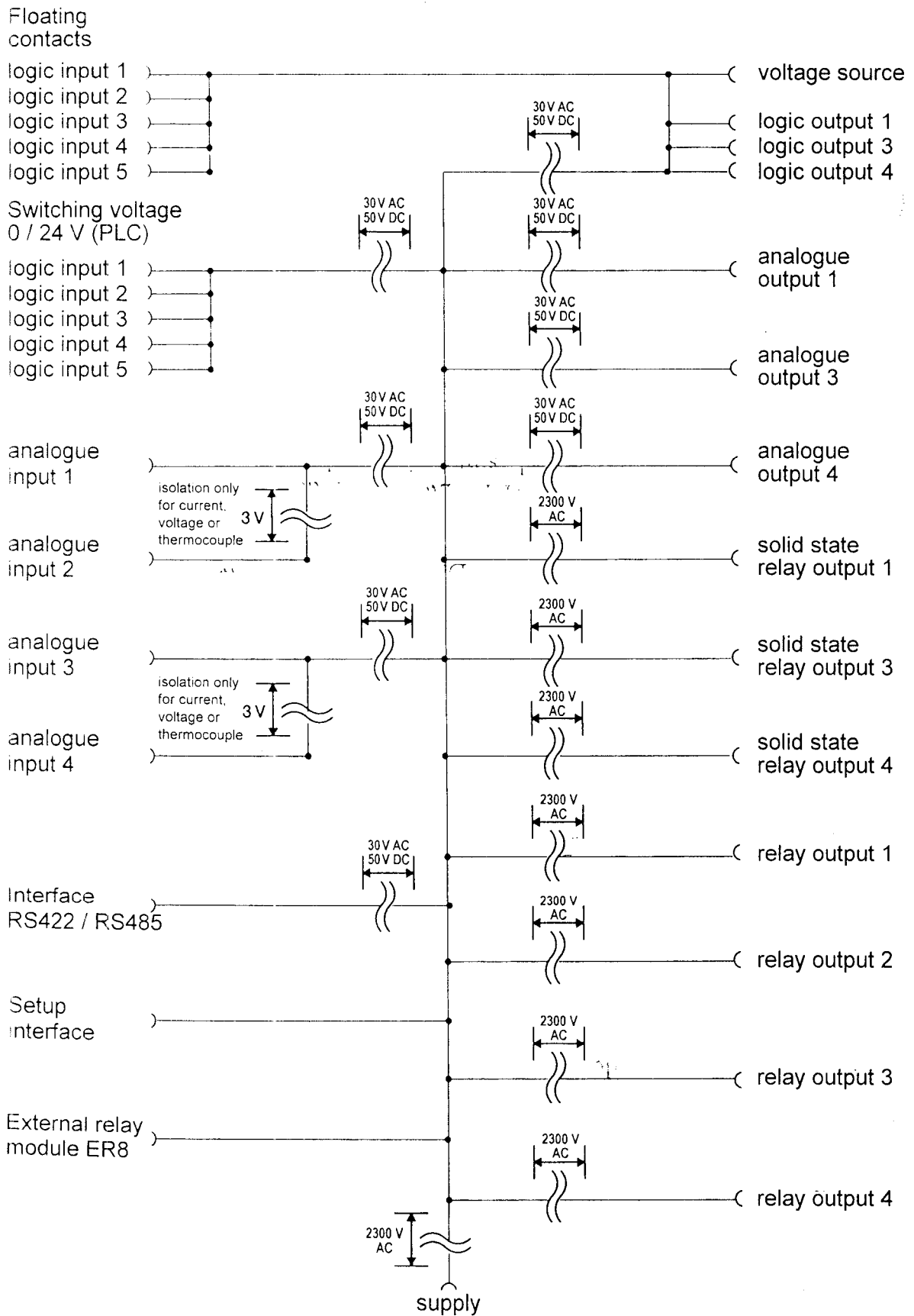

# 4 ELECTRICAL CONNECTION

## 4.3 Connection diagram

Rear view with screw terminals



The electrical connection must only be made by suitably qualified personnel.

Connect the controller connection TE to the system TE to discharge any interference potentials. If no TE connection is available, use the PE connection of the supply.

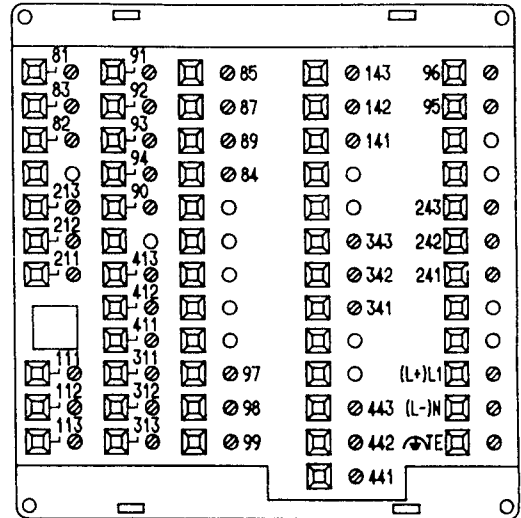

Outputs 1 to 4		Relay <sup>1</sup>	Solid state relay <sup>2</sup>	Logic outputs	Analogue outputs	Diagram
Relay, solid state relay or logic outputs analogue outputs	1	141 (O) n.c. (break) 142 (P) common 143 (S) n.o. (make)	142 143	142- 143+	142- 143+	
	2	241 (O) n.c. (break) 242 (P) common 243 (S) n.o. (make)				
	3	341 (O) n.c. (break) 342 (P) common 343 (S) n.o. (make)	342 343	342- 343+	342- 343+	
	4	441 (O) n.c. (break) 442 (P) common 443 (S) n.o. (make)	442 443	442- 443+	442- 443+	
External relay module ER8		97 RxD/TxD (+) 98 RxD/TxD (-) 99 GND	Communication with external relay module			
Interface RS 422	RxD	91 RxD (+) 92 RxD (-)	Receive data			
	TxD	93 TxD (+) 94 TxD (-)	Send data			
	GND	90 GND				
Interface RS 485	RxD/TxD	93 RxD/TxD (+) 94 RxD/TxD (-)	Receive/send data			
	GND	90 GND				

1. Contact protection circuit 22 nF / 56 Ω between common and make  
2. Varistor protection circuit 300 V

# 4 ELECTRICAL CONNECTION

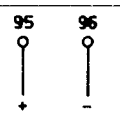
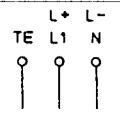
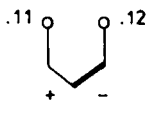
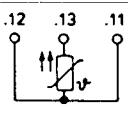
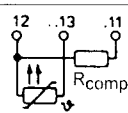
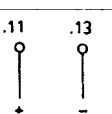
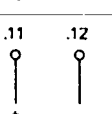
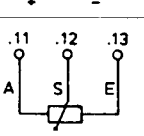
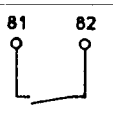
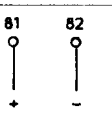
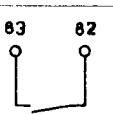
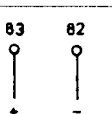
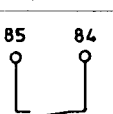
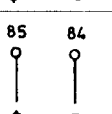
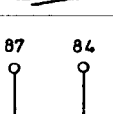
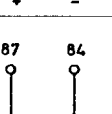
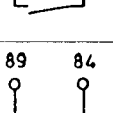
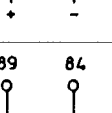
Output	Terminals	Supply	Diagram			
Supply for 2-wire transmitter	95 + 96 -	18 V 45 mA supply				
Supply as on label (UC = AC/DC)	TE L1 N	technical earth (ground) line neutral AC	L+ L- DC 			
Analogue inputs	Input 1	Input 2	Input 3	Input 4		
Thermocouple	111+ 112-	211+ 212-	311+ 312-	411+ 412-		
Resistance thermometer in 3-wire circuit	111 112 113	211 212 213	311 312 313	411 412 413		
Resistance thermometer in 2-wire circuit	111 112 113	211 212 213	311 312 313	411 412 413	$R_{comp} = R_{line}$	
Current input	111+ 113-	211+ 213-	311+ 313-	411+ 413-		
Voltage input	111+ 112-	211+ 212-	311+ 312-	411+ 412-		
Resistance transmitter	111 112 113	211 212 213	311 312 313	411 412 413	.11 start (A) .12 slider (S) .13 end (E)	
Logic inputs						
Logic input 1	81 82	Floating contacts or voltage 0 / 24 V (to special order)				
Logic input 2	83 82					
Logic input 3	85 84					
Logic input 4	87 84					
Logic input 5	89 84					

# 4 ELECTRICAL CONNECTION

## 4.4 Earth (ground) connection

Connect the controller connection TE with the system TE to discharge any interference potentials. If no TE connection is available, use the PE connection of the supply.

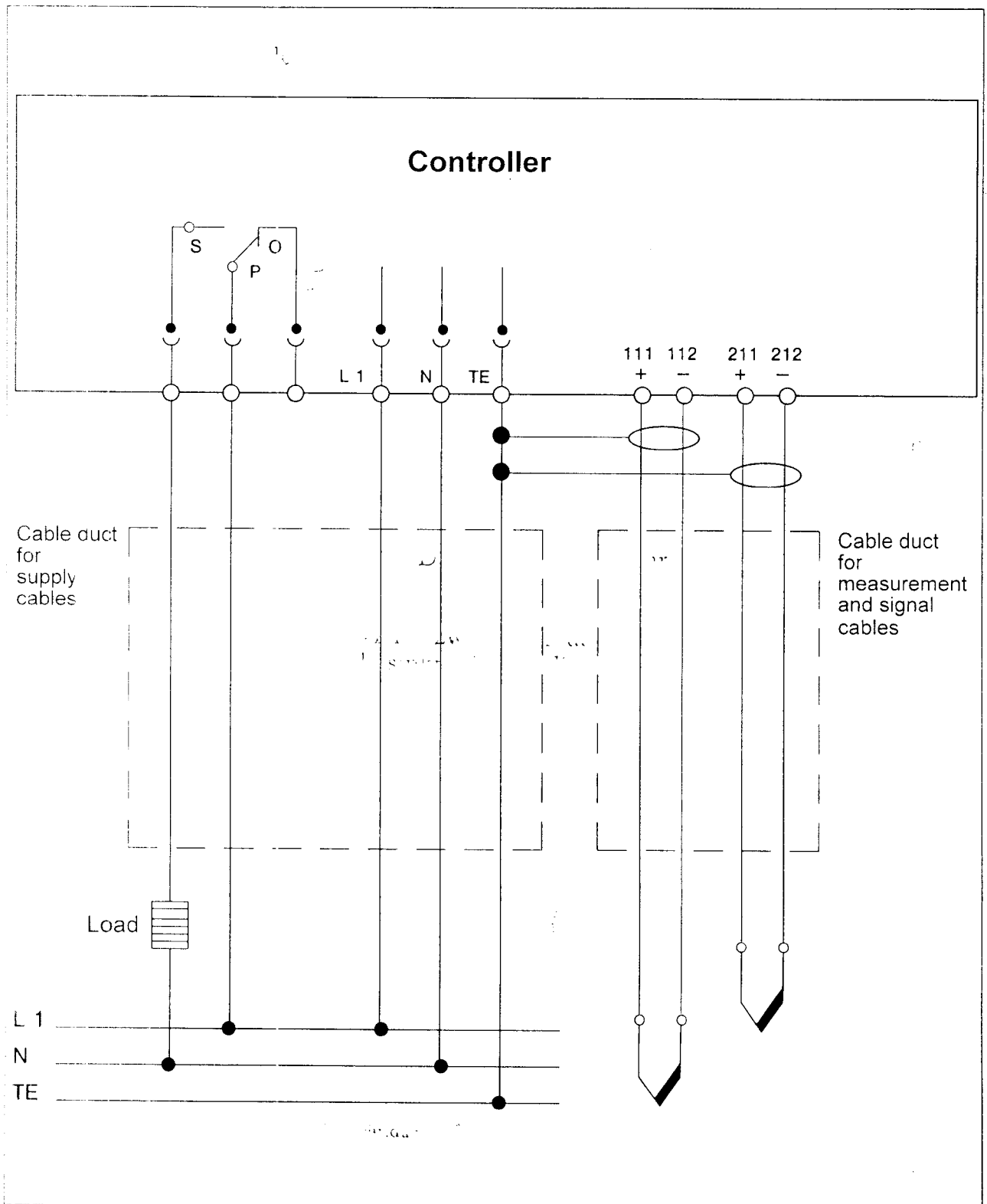

## 5 PREPARATION

### 5.1 Displays and keys on the front panel

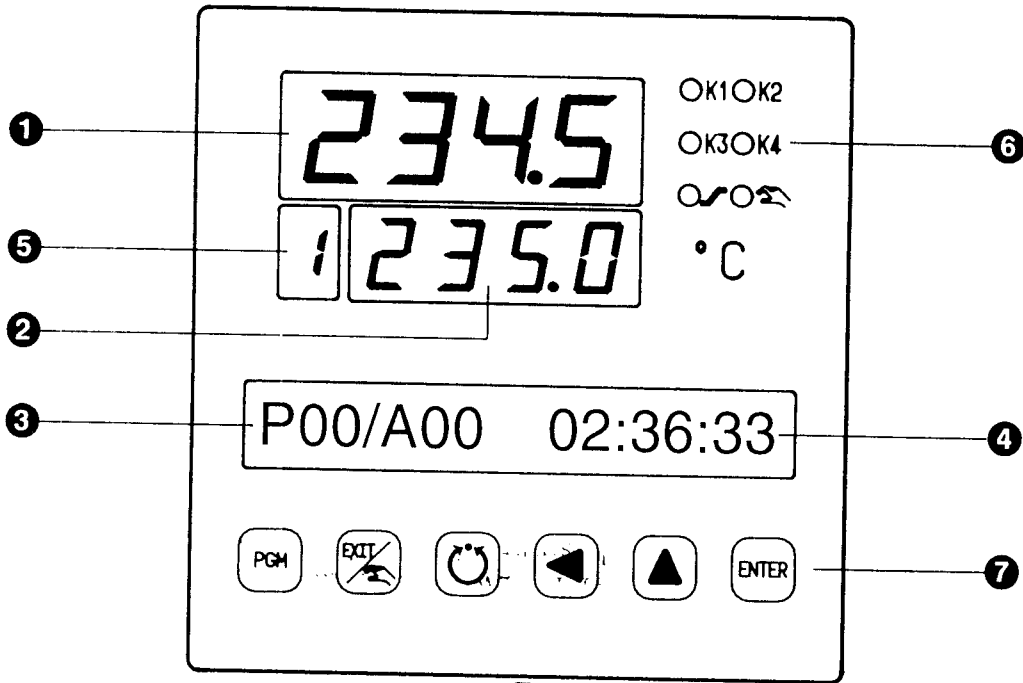

#### Displays

①		13 mm red display, can be configured (factory-set: process value)
②		10 mm green display, can be configured (factory-set: setpoint)
③, ④		green dot matrix display, can be configured (factory-set: profile status/residual profile time)
⑤		7 mm red channel display lights up when controller 2 is activated

#### Status indication













⑥	○K1 ... ○K4	lights up when switching outputs 1 to 4 are activated
	○ ○	lights up during automatic operation
	○	lights up during manual operation

#### Keys

⑦	PGM	programming		digit
	EXIT/ manual			increment
	ENTER			automatic operation

# 5 PREPARATION

## 5.2 Operating modes and states

Operating modes/states	Notes
Basic status	Initial status
Stopped	<p>Status after supply failure</p> <p>Message: <b>STOP</b></p> <p>The profile can be continued with  or aborted with <span style="border: 1px solid black; padding: 2px;">EXIT</span></p> <p> Section 19.5</p>
Operate, set parameters, configure	The user makes settings at levels and in menus
Auto operating mode	<p>A profile is running.</p> <p>Status display  lights up</p> <p> Section 7</p>
Manual operating mode	<p>The user operates process variables manually (activated from the basic status)</p> <p>Status display  lights up</p> <p> Section 6.1</p>
Auto-manual operating mode	<p>The user holds the current profile run.</p> <p>Status displays  and  light up</p> <p> Section 6.2</p>
Self-optimisation	<p>Message: <b>TUNE ACTIVE</b></p> <p> Sections 6.5, 9.4, 15.2</p>
Initialisation	<p>After connection to the supply all indications light up briefly.</p> <p>Display  is flashing.</p>
Automatic channel scrolling	 Section 9.5
Overrange / underrange / probe break	<p>Status signalled through the displays.</p> <p>The outputs move to defined states.</p> <p> Sections 11.5, 11.6, 19.3</p>

# 5 PREPARATION

## 5.3 Principle of operation

In order to obtain a clear picture of the many possible manipulations, the parameters and functions are arranged on seven different levels:

**Basic status**  
Initial condition

**Profile start**  
Here the profile program is selected and start time and start conditions are set.

**Profile program editor<sup>1</sup>**  
Here the profile programs are created (edited)

**Operating level**  
This level can be used to program setpoints, activate operating modes, and indicate various process parameters.

**Parameter level<sup>1</sup>**  
The parameters at this level are used to adjust the controller to the control loop. A total of four parameter sets each for controller 1 and controller 2 are provided.

**Configuration level C1<sup>1</sup>**  
This level serves to adapt the controller to the control task. It contains data specific to the controller (controller types, inputs and outputs, etc.)

**Configuration level C2<sup>1</sup>**  
This level also serves to adapt the controller to the control task. It contains data specific to the system (displays, interface etc.)

**Configuration level C3 (Codes)**  
The parameters at this level contain the extra Codes for hardware and software in accordance with the controller specification:

No data can be input at this level. It changes automatically on alterations and retrofitting of hardware or software.

**Service mode<sup>1</sup>**  
Only accessible to service personnel

<sup>1</sup>. protected by access code.

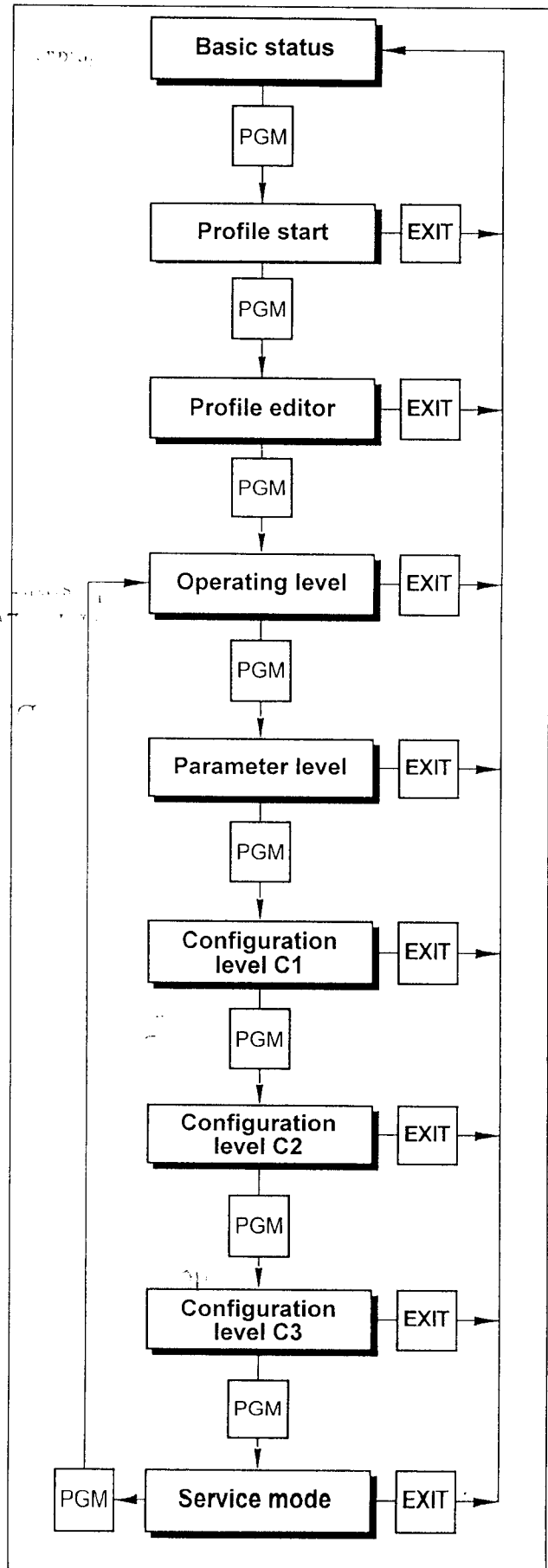

# 5 PREPARATION

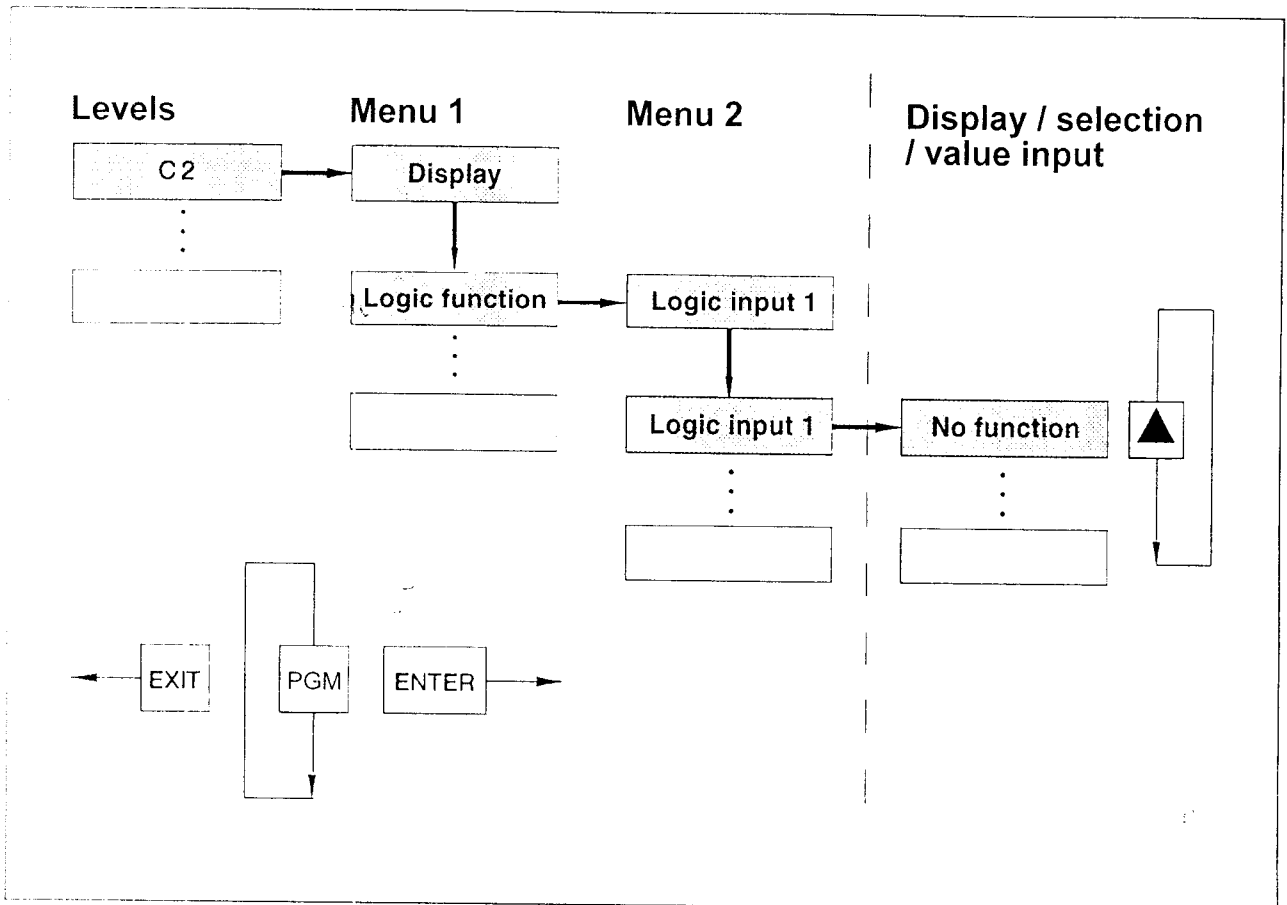

From the operating level onwards every level is divided into **menus** whose number varies. This results in a tree-like structure.

In order to alter a certain parameter the user runs through the levels and menus according to the menu items and finally reaches a **selection** (of functions) or a **value input**.

For operator guidance the controller is provided with a matrix display which permits displaying alphanumerical characters. In this way the operator is assisted by messages and notes in plain language.

During programming of the controller the menu items contained in the level and menu structure appear on the matrix display in plain language.

The selection from a list of functions and the value input are also presented through messages in plain language.

↪ The factory settings at the operating and parameter levels as well as at the configuration levels C1 and C2 are described in Sections 9, 10, 11 and 12.

↪ A simplified operating scheme entitled "**Overview of the key functions**" appears on the fold-out at the beginning of the Operating Manual. Exceptions in the key functions are specially mentioned.

## Time-out function

The time-out function is activated when the controller is in the operating, parameter or configuration mode (exception: profile program editor).

If no key is pressed for about 30 seconds the controller automatically returns to the standard display.

If this time is not sufficient it can be altered at configuration level C2.



➔ Section 12.6

# 5 PREPARATION

## Selection

Here a function is selected from a list. On scrolling the functions appear on the matrix display, e.g.

PROCESS VALUE

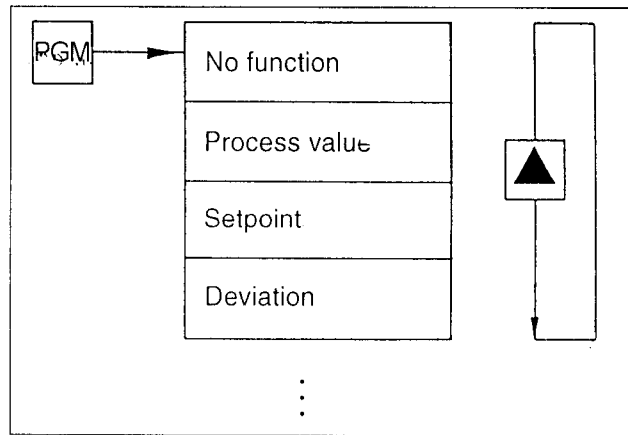

- \* Select function with  (matrix display is flashing!)
- \* Enter with 





## Value input

Here a value is assigned to a menu item in the matrix display.

SETPOINT 100.

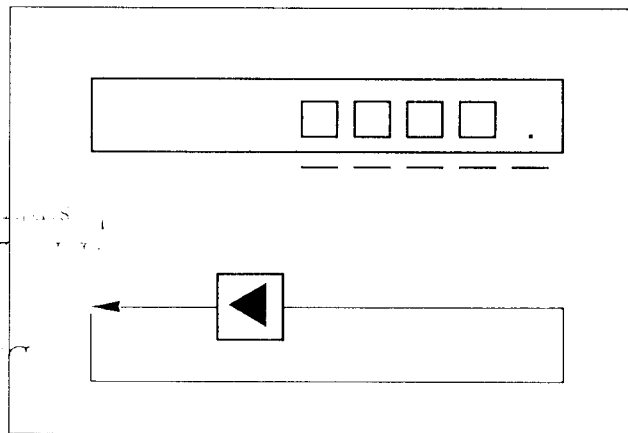
- \* Select digit with  (selected digit is flashing!)
- \* Alter value or shift decimal point with  The sign is altered in the fourth place from the right (- / -1).
- \* Enter with 



-  - If an illegal value is input the matrix display shows the minimum or maximum permitted value. The display is flashing.
  - \* Repeat the input
- If the value can not be represented using the selected decimal point, special characters appear instead of the numbers.

SETPOINT \* \* . \* \*

- \* Shift decimal point
- A value consists of a maximum of 4 places. (before + after the decimal point)

# 5 PREPARATION

## 5.4 Level inhibit and access code

The parameter level and the configuration levels C1 and C2 as well as the customized recalibration, the profile program editor and the menu "delete profile" are protected by a 4-digit numerical access code. If one of these levels or menu items is selected the controller requests the access code.

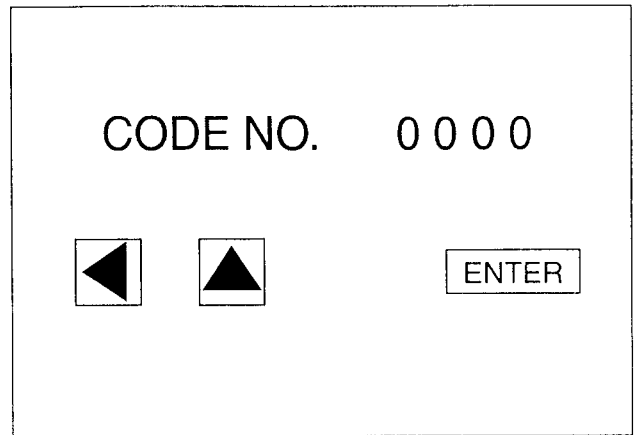

### Factory-set codes

Profile program editor	1000
Parameter level	0001
Configuration level C1	0002
Configuration level C2	0003
Customized recalibration	0004
Delete profile	1001



The access codes can only be changed through the setup program.

Parameter level and configuration levels C1 and C2 can be inhibited through a logic input. Access to these levels via the keys is then no longer possible.



Sections 12.3, 14.2

# 6 OPERATION

## 6.1 Manual operation

The manual operating mode is activated from the basic status. The current process value is taken as the setpoint.

\* Activate manual operation with 

\* Exit manual operation with **EXIT**  
(may have to be pressed several times)

The functions of manual operation are arranged in menus.

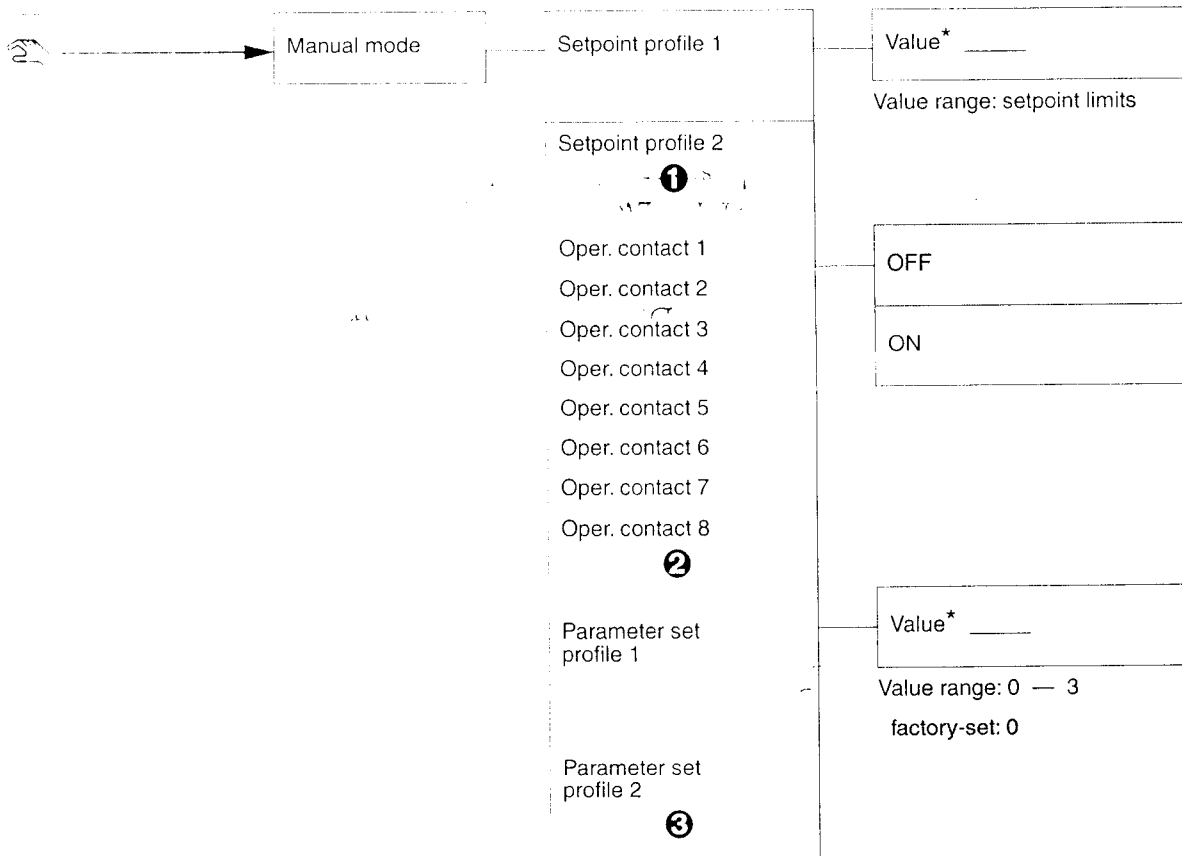



No.	Concept	Display	Notes
①	Setpoint profile program 1	SETP.ZP1	—
②	Operating contact 1	OPER.LINE1	—
③	Parameter set profile program 1	PARAM.ZP1	—

# 6 OPERATION

## 6.2 Auto-manual operation

This function is activated from automatic operation.

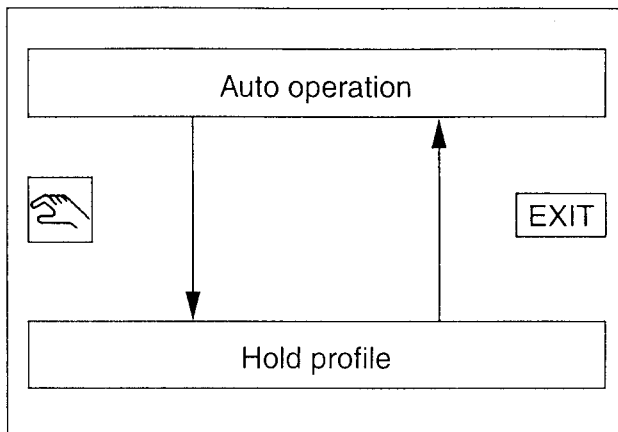

- \* Activate auto-manual operation with 
- \* Exit auto-manual operation with 

It serves to hold the profile run. The controller controls at the current setpoint. The operating contacts keep their current status.



## 6.3 Profile start

A profile is started from the basic status

- \* Activate auto operation with 
- \* Abort the profile with 

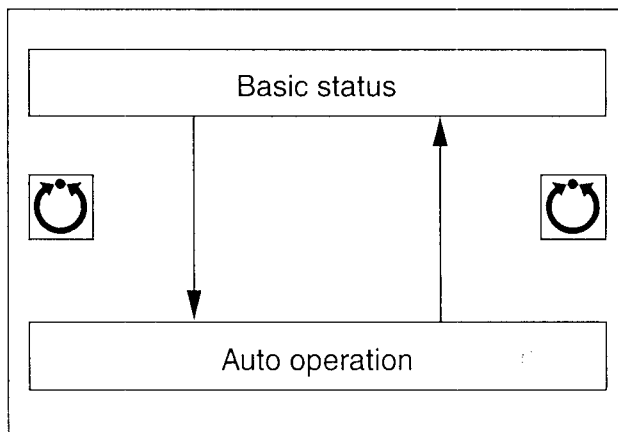

 The parameters defined at the "profile start" level are valid.



## 6.4 Fast forward

Fast forward causes the profile controller to continue profile program 1 with the beginning of the next segment.

Profile program 2 and the operating contacts are moved along in synchronism.

- \* Switch over to the next segment with  + 

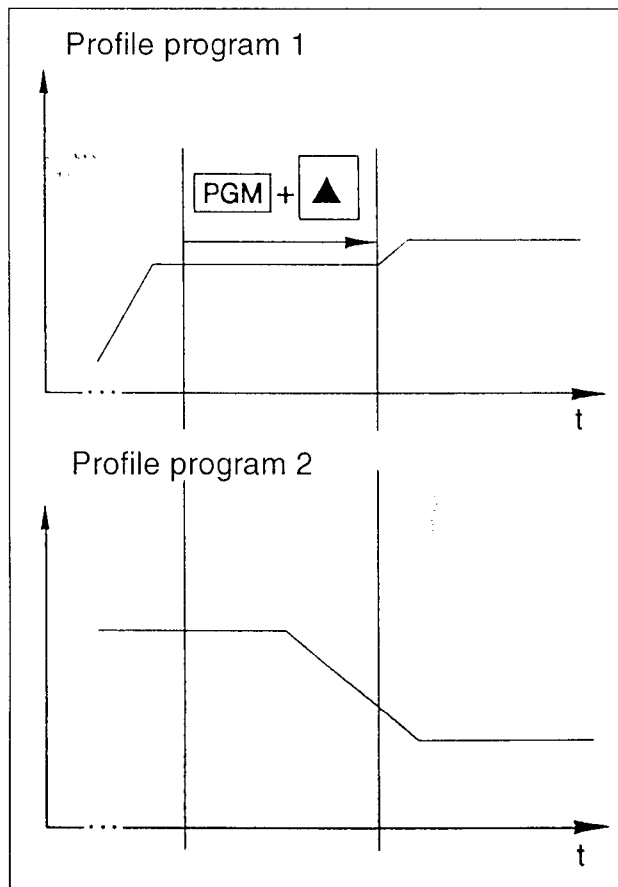

# 6 OPERATION



## 6.5 Self-optimisation

The self-optimisation function can be started to adjust the controller parameters to the control loop.



Self-optimisation can be started from manual operation.

### Operating with keys:

- \* Start with  and   
(press both keys simultaneously)
- \* Abort with 

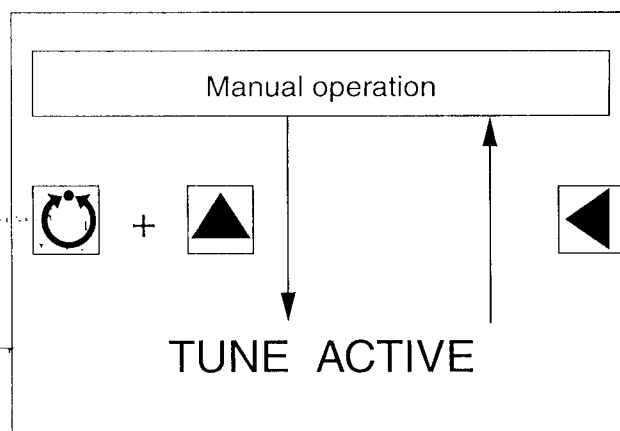

### Operating through menu item:

 OPERATING LEVEL: self-optimisation, Section 9.6

- \* Start self-optimisation by selecting:

**TUNE C1 ON**

- \* Abort self-optimisation by selecting:

**TUNE C1 OFF**

 Sections 9.6, 14.2, 15.2

# 6 OPERATION

## 6.6 Channel changeover

 Only when controller 2 is activated (channel indication is illuminated)

The process variables of the controllers are shown (depending on configuration) on the front displays. It is possible to switch over between the displays of the process variables of the two controllers.

### Operating with keys:

- \* Changeover controller 1 - controller 2 with **ENTER**

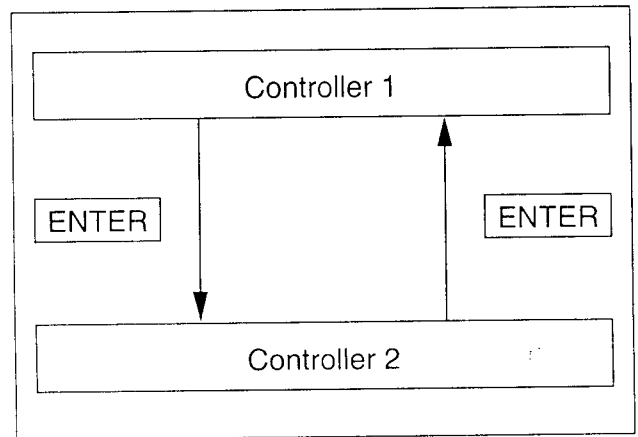

### Operating through menu item:

 OPERATING LEVEL: channel changeover, Section 9.8

 Operating through the keys (setpoint alteration, start of self-optimisation, manual operation) refers to the controller whose process variables are shown on the displays.

 During manual operation, channel changeover is possible only at the operating level.

# 7 PROFILE START

To start a profile run at a certain time it is necessary to program either the start time and the start day, or alternatively a start delay time. The form of programming depends on whether the real time clock is activated.



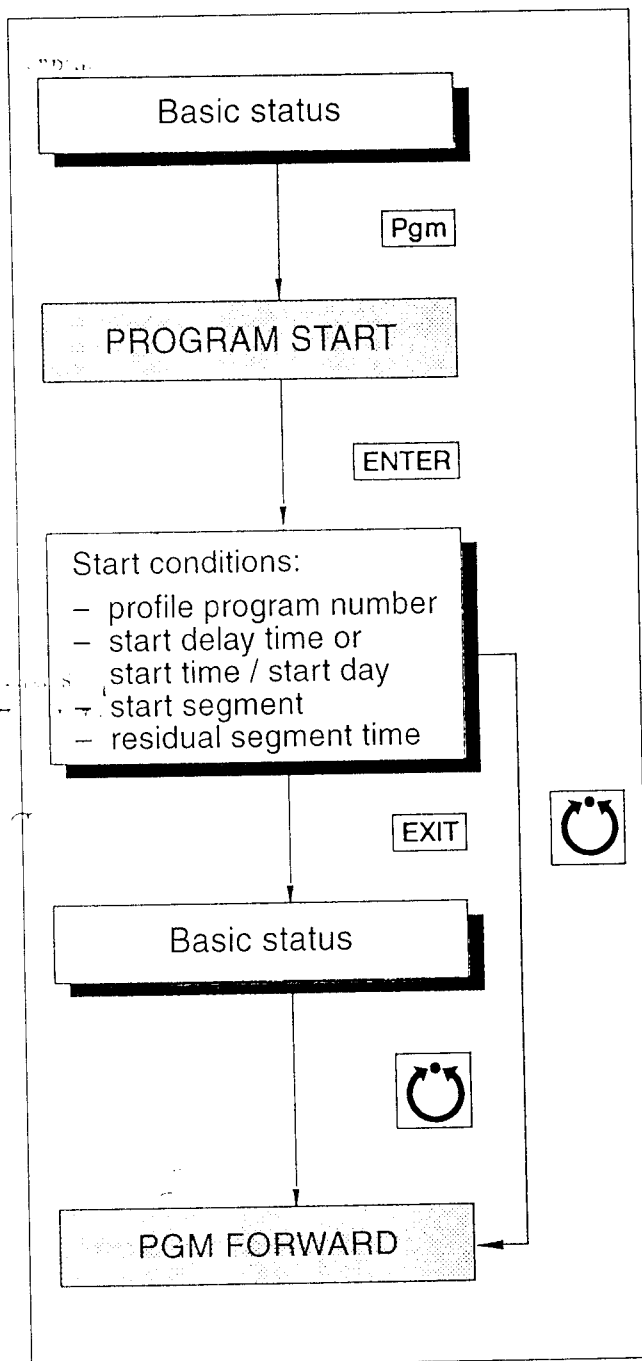

Section 12.10

- \* Change to "profile start" level with **PGM**
- \* Enter with **ENTER**
- \* Program the start conditions
- \* Return to basic status with **EXIT**
- \* Start the profile delay time with **⏪**

 After a profile run has been completed the start conditions are reset to their standard values.



# 7 PROFILE START

Item	Display	Notes
Profile program number	PROG.NO. 00.	Value range: 0 — 24 normally: last profile program executed
Start time	START 00:00:00	time of profile start Value range: 00:00:00 — 23:59:59 format: hh:mm:ss normally: current clock time   If the real time clock is activated the current clock time is shown as default setting. If the real time clock is not activated this parameter does not appear on the display.   Section 12.10
Start day	STARTDAY MO	weekday of profile start Value range: MO, TU, WE, TH, FR, SA, SU normally: current weekday   If the real time clock is activated the current weekday is shown as default setting. If the real time clock is not activated this parameter does not appear on the display.
Delay time	DELAY 00:00:00	time delay up to the start of the profile Value range: 00:00:00 — 99:59:59 format: hh:mm:ss normally: 00:00:00   This parameter is displayed only if the real time clock is inactivated.   Section 12.10
Start segment	STARTSEGM. 0	number of the segment with which the profile is to start. Value range: 0 — 99 normally: 0
Residual segment time	RESTSEG 00:00:00	residual running time of the start segment Value range: 00:00:00 — 99:59:59 format: hh:mm:ss normally: 00:00:00  00:00:00 = start at the beginning of the start segment. If the residual segment running time is larger than the segment time the profile still starts at the beginning of the start segment.

# 8 PROFILE PROGRAM EDITOR

## 8.1 General notes

Profile programs are created by programming for each segment the setpoint and the segment time or the gradient.

 The programming mode (setpoint/segment time or setpoint/gradient) can be configured and applies to the entire profile programming procedure.

 Section 11.7

In addition the states of the operating contacts 1 to 8 and the active parameter set can be defined for each segment.

 The output of the setpoint profiles can be either as ramps or as steps (this can be configured).

 Section 11.7

The output as ramps has been selected for the illustrations below.

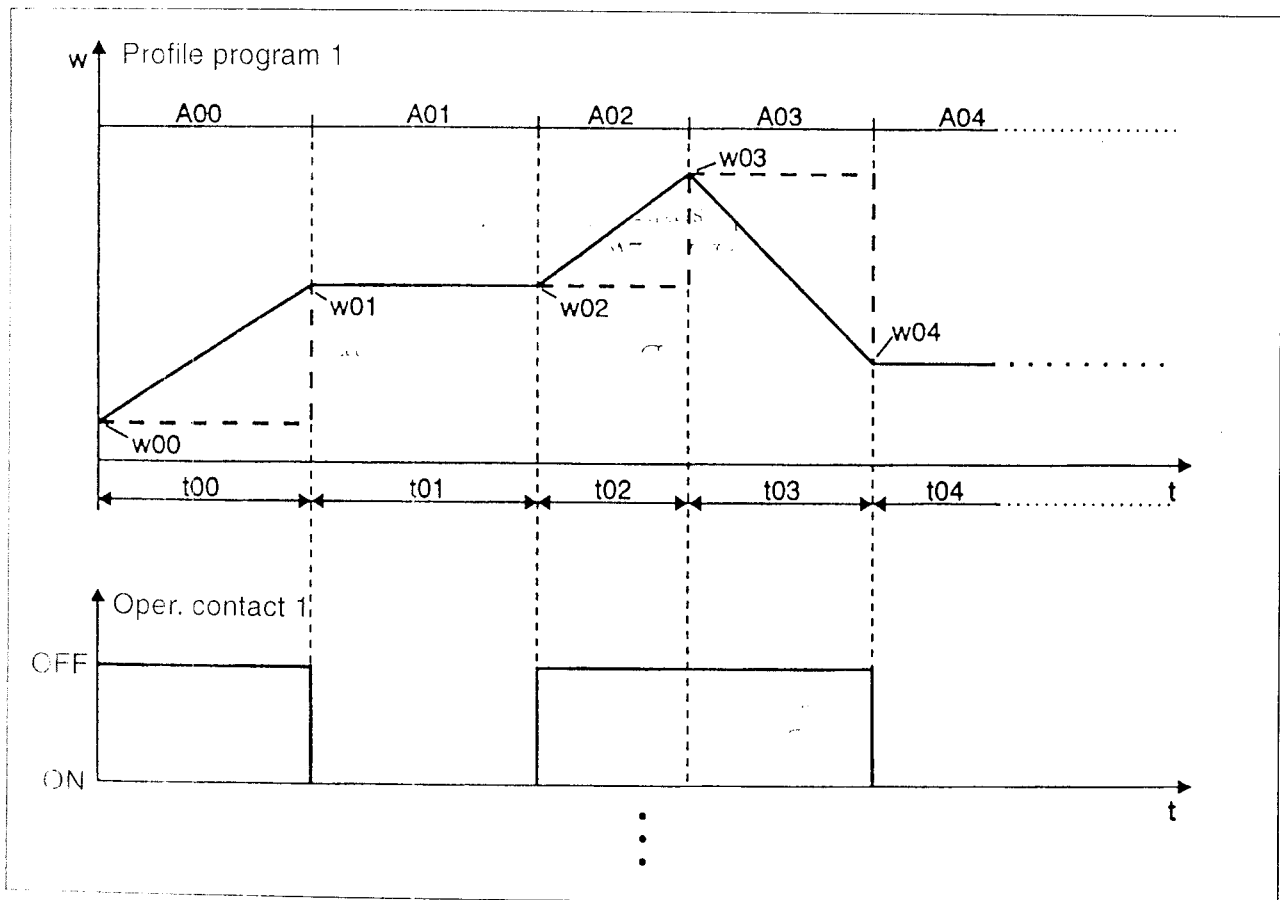

The states of the operating contacts are determined by OR linkages of the inputs for profiles 1 and 2.

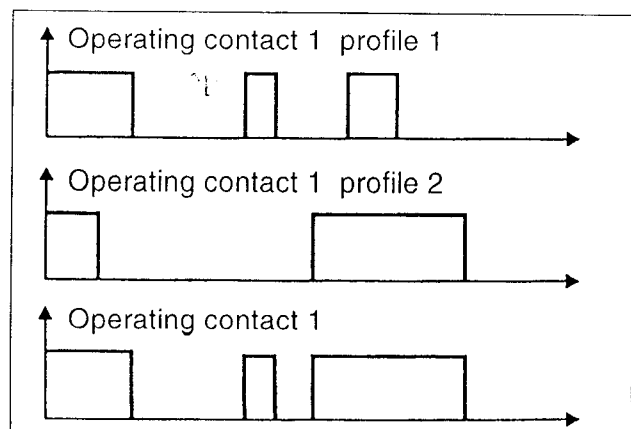

# 8 PROFILE PROGRAM EDITOR

## 8.2 Overview

Profile program number

Value\*  ①

Value range 0 — 24

Profile 1

Profile 2 ②

Edit segment

③

Insert segment

④

Segment No.

Value\*  ⑤

Value range: 0 — 99

Setpoint

Value\*  ⑥

Value range:  
setpoint limits

factory-set: 0

Segment time

Value\*  ⑦

Value range:  
00:00:00 — 99:59:59

factory-set: 00:00:00

Gradient

Value\*  ⑧

Value range:  
0 — 999 °C/min

factory-set: 0 °C/min

Repeat cycles

Value\*  ⑨

Value range: -1 to +99

factory-set: 0

Target segment

Value\*  ⑩

Value range: 0 — 99

factory-set: 0

Operating contact 1 ⑪

Operating contact 8

OFF

ON

Lower tolerance limit

Value\*  ⑫

Value range:  
-1999 to +9999

factory-set: -1999

Upper tolerance limit

Value\*  ⑬

Value range:  
-1999 to +9999

factory-set: +9999

Parameter set number

Value\*  ⑭

Value range: 0 — 3

factory-set: 0



### Explanation:

\* = input a value

= factory setting

# 8 PROFILE PROGRAM EDITOR

## Overview

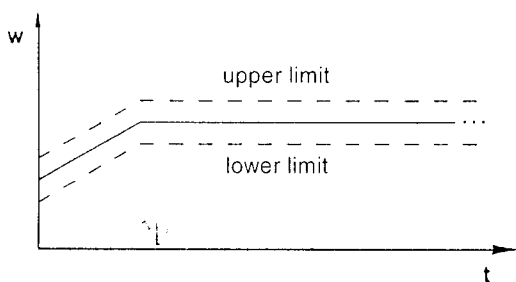
No.	Item	Display	Notes
❶	Profile prog. No.	PROG.NO. 0.	Value range: 0 — 24
❷	Profile 1	TIME PRG1	—
❸	Edit segment	EDIT SEGMENTS	—
❹	Insert segment	INSERT SEGM.	—
❺	Segment number	SEGM.NO. 0.	Value range: 0 — 99
❻	Setpoint	SETPOINT 0.	Value range: setpoint limits Section 11.7
❼	Segment time	STPTIME 00:00:00	Value range: 00:00:00 — 99:59:59 format: hh:mm:ss   Parameter is displayed only when time programming is activated Section 11.7
❽	Gradient	GRADIENT 0.	Value range: 0 — 999 °C/min   Parameter is displayed only when gradient programming is activated Section 11.7
❾	Repeat cycles	CYCLES 0.	Value range: -1 to +99 -1 = indefinite repeat
❿	Target segment	FIN.SEGM. 0.	Value range: 0 — 99
⓫	Oper.contact 1	OPER.LINE1 OFF	—
⓬	Lower tolerance limit	TOL.MIN. -1999.	Value range: -1999 to +9999 digit    If the actual value goes overlimit or underlimit an output can produce a signal if suitably configured, and operation can be switched to auto-manual. Section 11.7
⓭	Upper tolerance limit	TOL.MAX. 9999.	
⓮	Parameter set number	PARAM.SET. 0.	Value range: 0 — 3 0 = parameter set 1

# 8 PROFILE PROGRAM EDITOR

## Overview (continued)

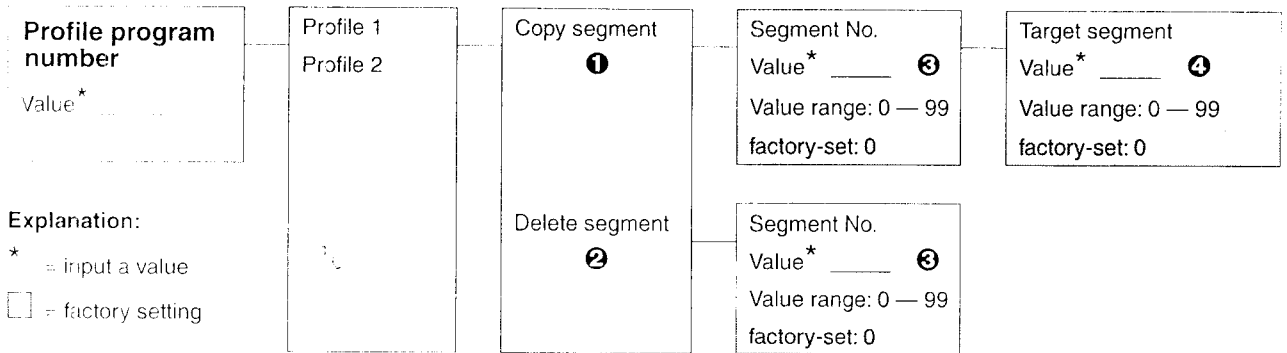

No.	Item	Display	Notes
❶	Copy segment	COPY SEGMENTS	—
❷	Delete segment	DELETE SEGM.	—
❸	Segment number	SEGM.NO. 0.	Value range: 0 — 99
❹	Target segment	FIN.SEGM. 0.	Value range: 0 — 99

# 8 PROFILE PROGRAM EDITOR

## 8.3 Creating profile programs

- \* Change to profile program editor with 2x **PGM**
- \* Enter with **ENTER**
- \* Input the access code
- \* Enter with **ENTER**
- \* Input the profile program number
- \* Select the profile
- \* Create the profile



The time-out function is not activated within the profile program editor.

## 8.4. Editing segments

An existing segment can be edited.

When creating a new profile the segments have to be edited in sequence.

The input is rejected if the segment number is input when the preceding segment has not yet been defined. The segment following the last defined segment is indicated (display flashing).

A segment is defined by the input of setpoint and segment time or gradient.



A segment is not accepted if the segment time is 0.

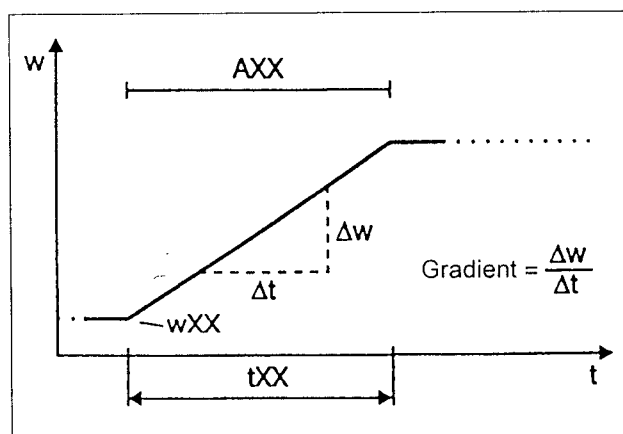

# 8 PROFILE PROGRAM EDITOR

## 8.5 Inserting segments

Segments can be inserted at any point of the profile. The subsequent segments are renumbered automatically. The parameters of the inserted segment (in this example A01) are set to standard default values.

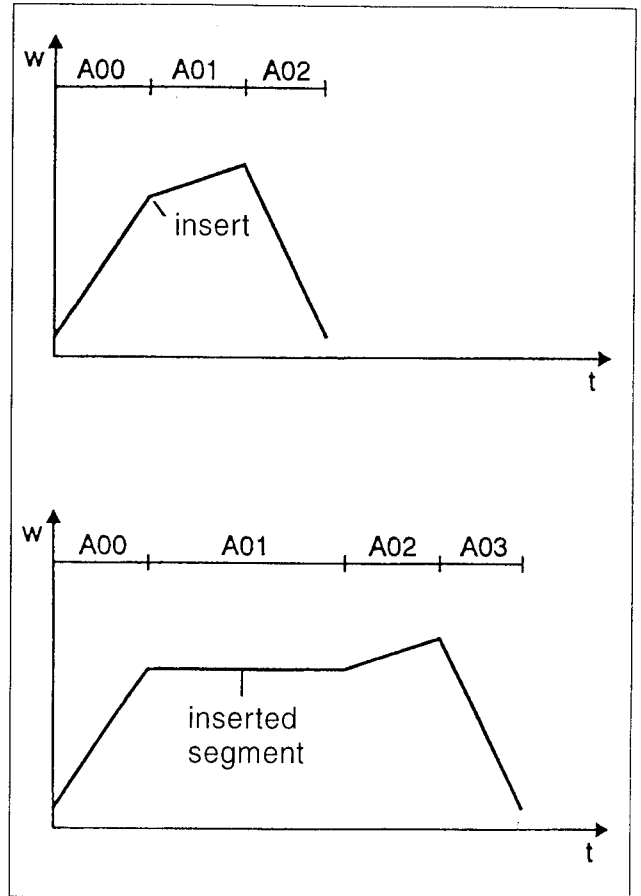

## 8.6 Copying segments

Segments which have already been defined can be copied into other segments or can be added to a series of defined segments.

# 8 PROFILE PROGRAM EDITOR

## 8.7 Deleting segments

If a segment is deleted, the subsequent segments close up and are renumbered automatically. The profile changes according to the programmed setpoints.

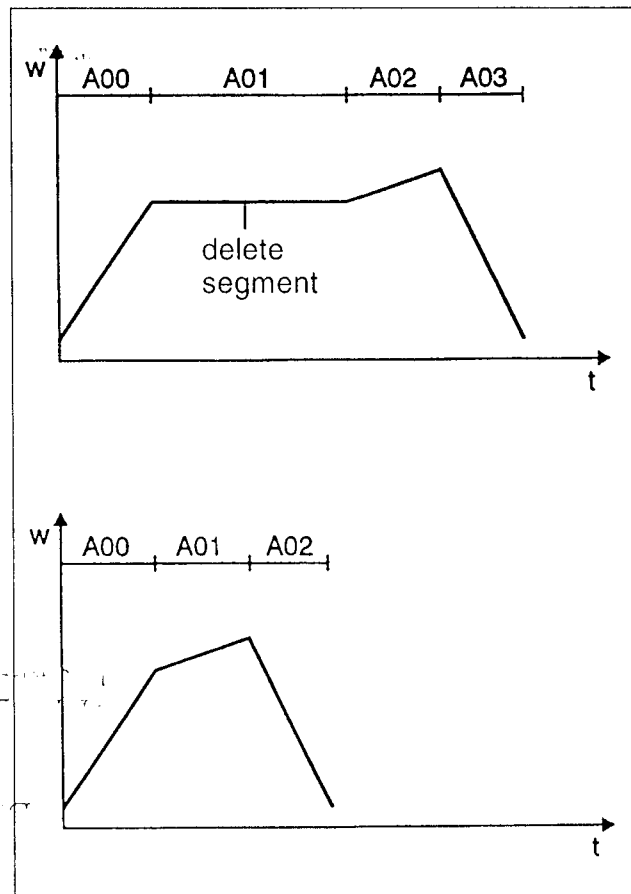

## 8.8 Programming repeat cycles

A group of consecutive segments can be repeated up to 99 times or indefinitely. Repeat cycles are programmed in the menu of the last segment of the group.

The first segment of the group is defined under "target segment".

Example: A01 - A03 has to be repeated once.

- \* Edit segment 3
- \* Set repeat cycles to "1"
- \* Set target segment to "1"

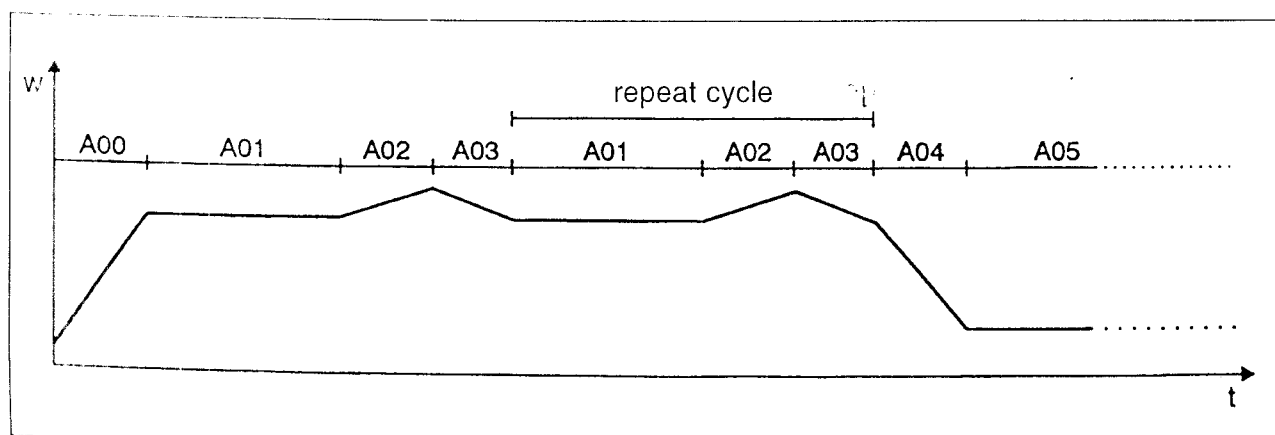

# 8 PROFILE PROGRAM EDITOR

## 8.9 Temporary alterations

Temporary alterations are alterations of the current profile in the profile program editor. They are not stored in the profile program store, i.e. these alterations are lost on re-start.

Profile a: setpoint profile following alterations in the current segment

Profile b: setpoint profile with subsequent segments and re-start after supply failure or in repeat cycles

### Altering the setpoint in the current segment

If the setpoint is altered at time  $t_0$  the setpoint profile continues with the newly input setpoint. During the residual running time of the segment the profile approaches the setpoint of the following segment (profile a)

Example:  
alteration in A02  
segment setpoint 10 → 60

### Altering the setpoint in the subsequent segment

If the change is made at time  $t_0$ , the setpoint which has been input is approached during the remaining segment time. The gradient of the ramp is altered (profile a).

Example:  
alteration in A03  
segment setpoint 50 → 60

### Altering the segment time of the current segment

If the segment time is altered, the subsequent setpoint is approached during the remaining segment time (profile a).

If the new segment time is shorter than the elapsed time of this segment, the setpoint profile is continued at the start of the next segment.

Example:  
alteration in A02  
segment time 4 h → 3 h

Example

Segment	Segment setpoint	Segment time
A00	7	1 h
A01	10	1 h
A02	50	4 h
A03	50	1 h

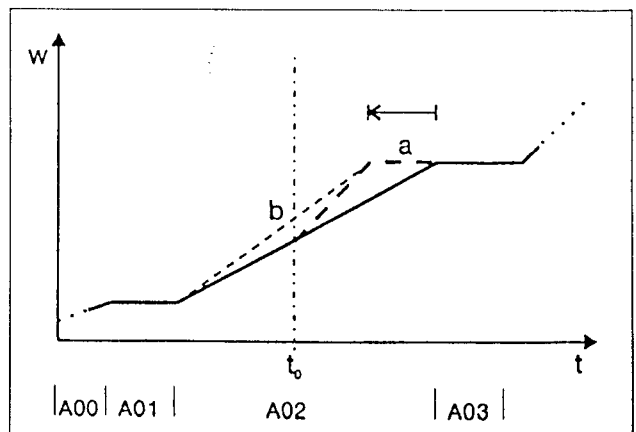
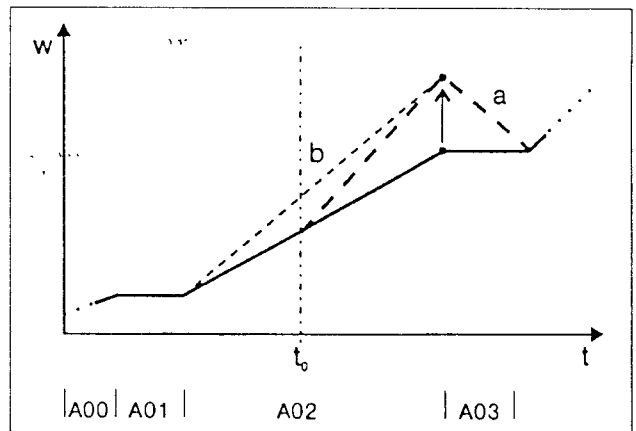
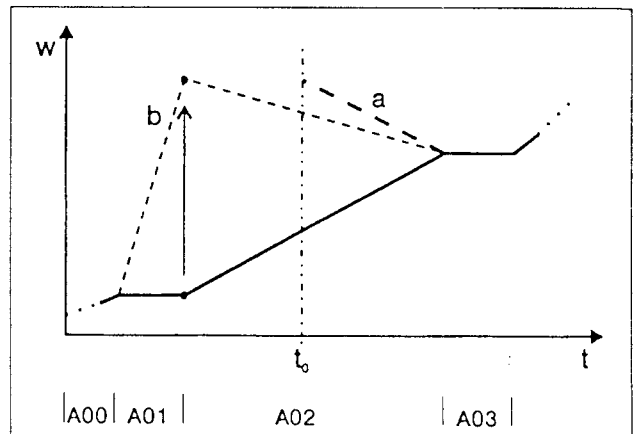

# 9 OPERATING LEVEL

---

## 9.1 Overview

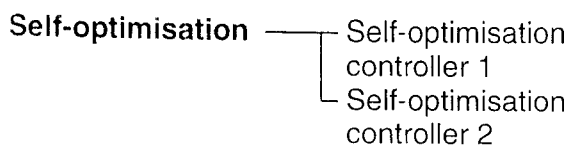
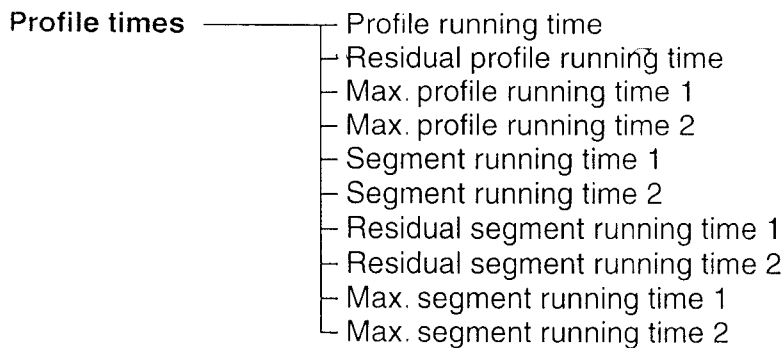
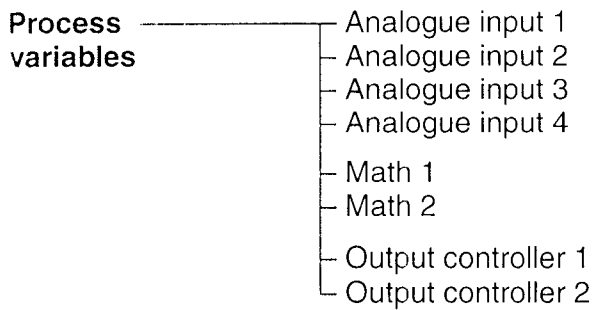
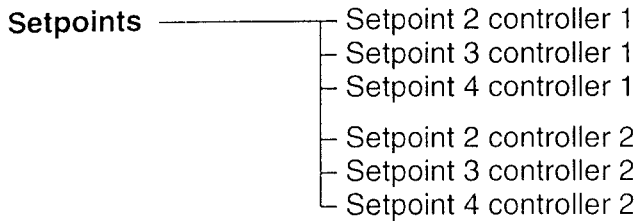

**Automatic channel scrolling**



# 9 OPERATING LEVEL

## 9.2 Setpoints

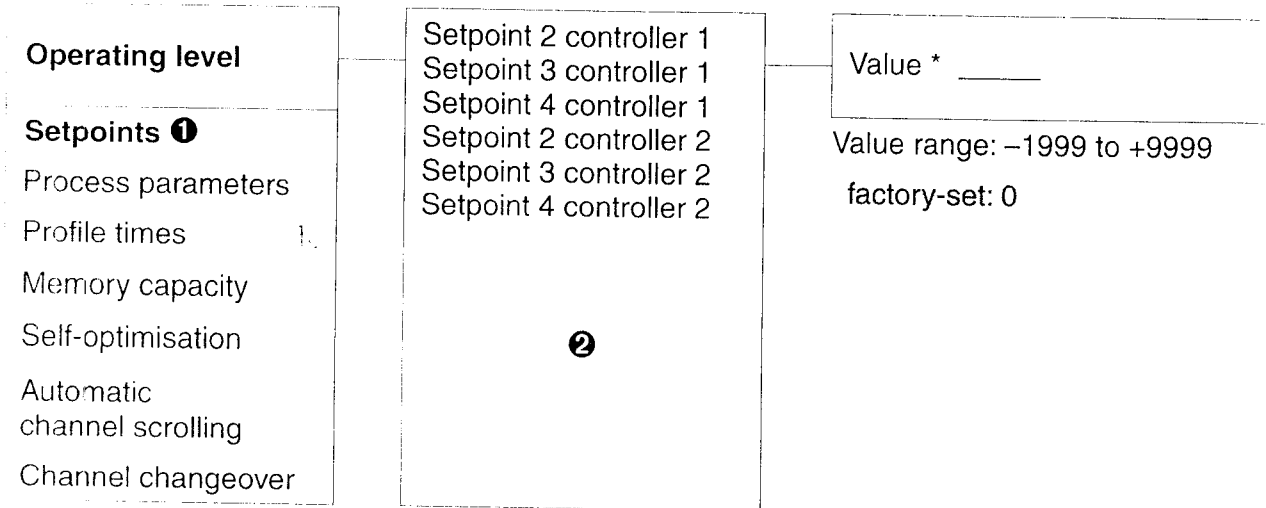

### Setpoints

No.	Item	Display	Notes
①	Setpoints	SETPOINTS	<p>Each of the two controllers can have four setpoints (keyed-in setpoint + 3 extra setpoints). The setpoints are switched over through logic inputs.</p> <p>↳ Configuration level C2:                      Logic functions → ... →                      setpoint changeover                      controller 1/2                      Section 12.3</p> <p>↳ Section 14.1</p>
②	Setpoint 1 controller 1	SETPOINT C1	—

# 9 OPERATING LEVEL

## 9.3 Process variables

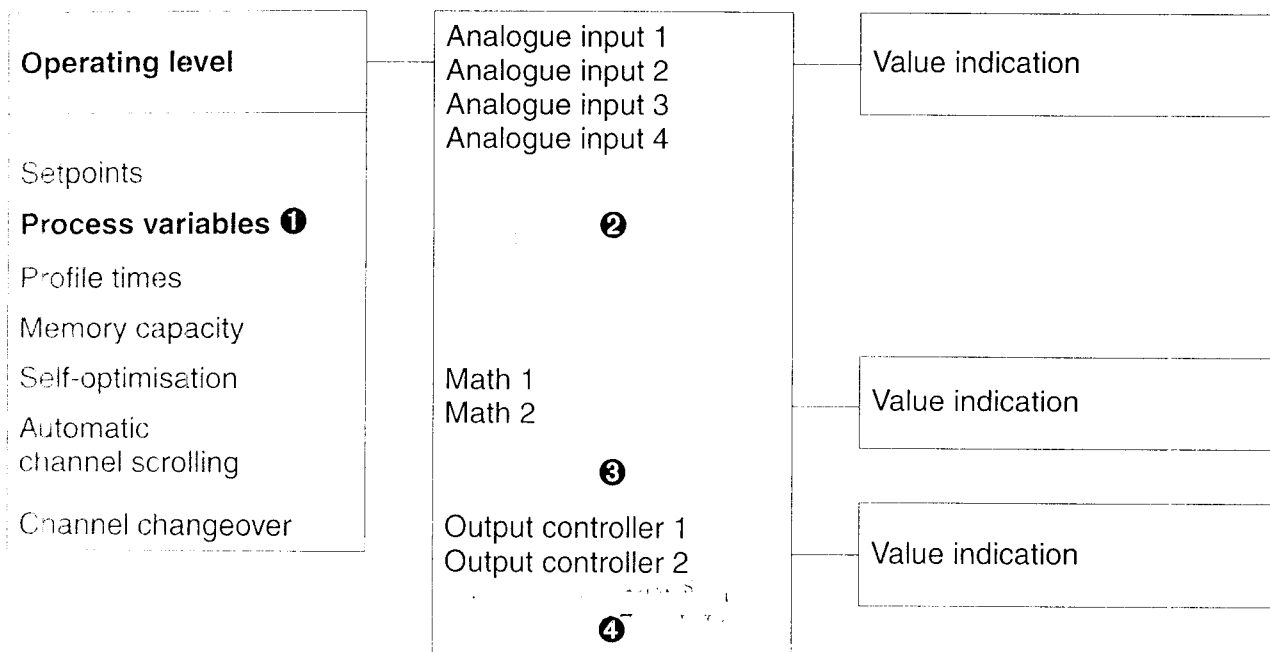

### Process variables

No.	Item	Display	Notes
①	Process variables	PROC. VARIABLES	Here the different process variables are shown on the matrix display.
②	Analogue input 1	ANALOG IN1	Value of the selected analogue input 1 — 4.
③	Math 1	MATH 1	Result of a mathematical operation. The formulae are entered in the setup program.   Configuration level C1 Sections 11.7, 16.3, 17.12
④	Output controller 1	OUTPUT C1	Output in %

# 9 OPERATING LEVEL

## 9.4 Profile times

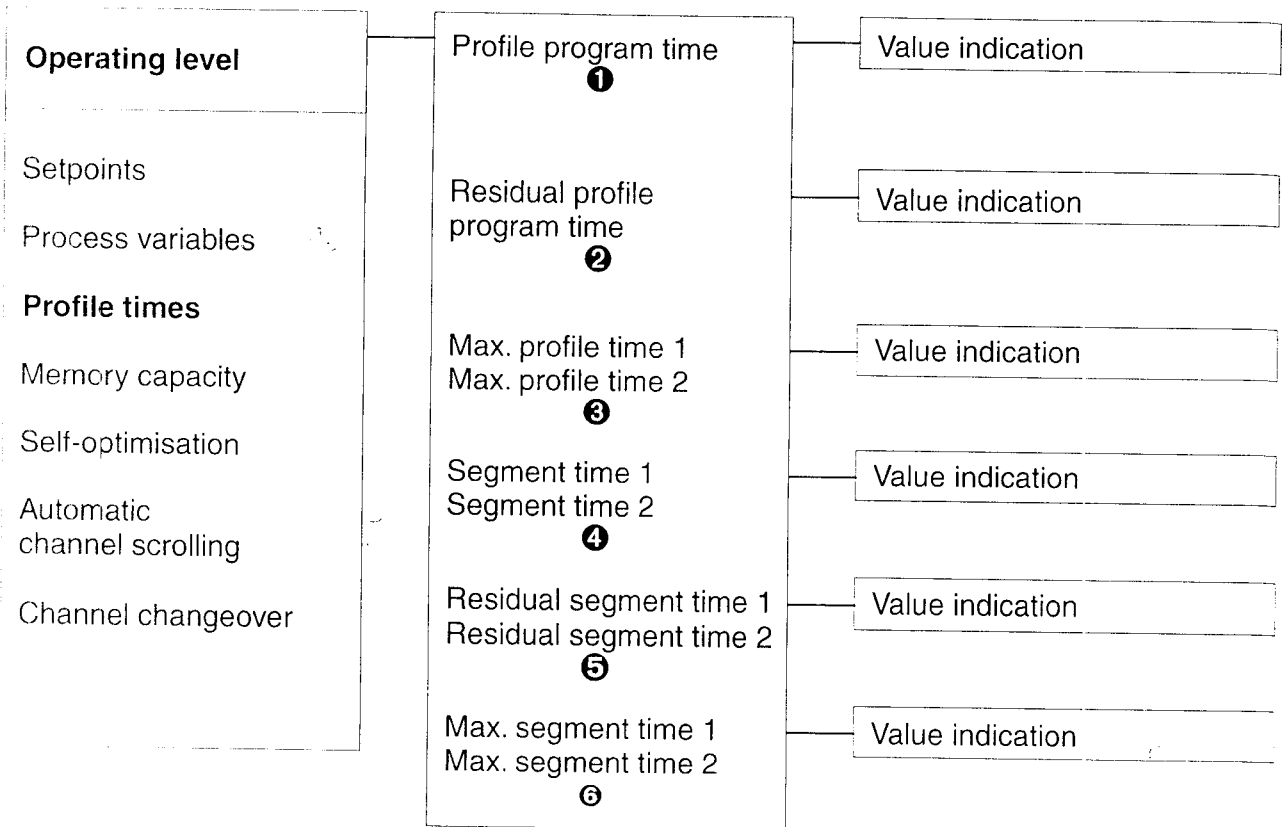

No.	Item	Display	Notes
<b>①</b>	Profile program time	P.TIME	
<b>②</b>	Residual profile program time	P.REST	
<b>③</b>	Max. profile time 1	P-MAXT1	
<b>④</b>	Segment time 1	S-TIME1	
<b>⑤</b>	Residual segment time 1	S-REST1	
<b>⑥</b>	Max. segment time 1	S-MAXT1	

# 9 OPERATING LEVEL

## 9.5 Memory capacity



No.	Item	Display	Notes
①	Free segments	FREE SEG.	Total number of the free (programmable) segments (500 max.)

# 9 OPERATING LEVEL

## 9.6 Self-optimisation

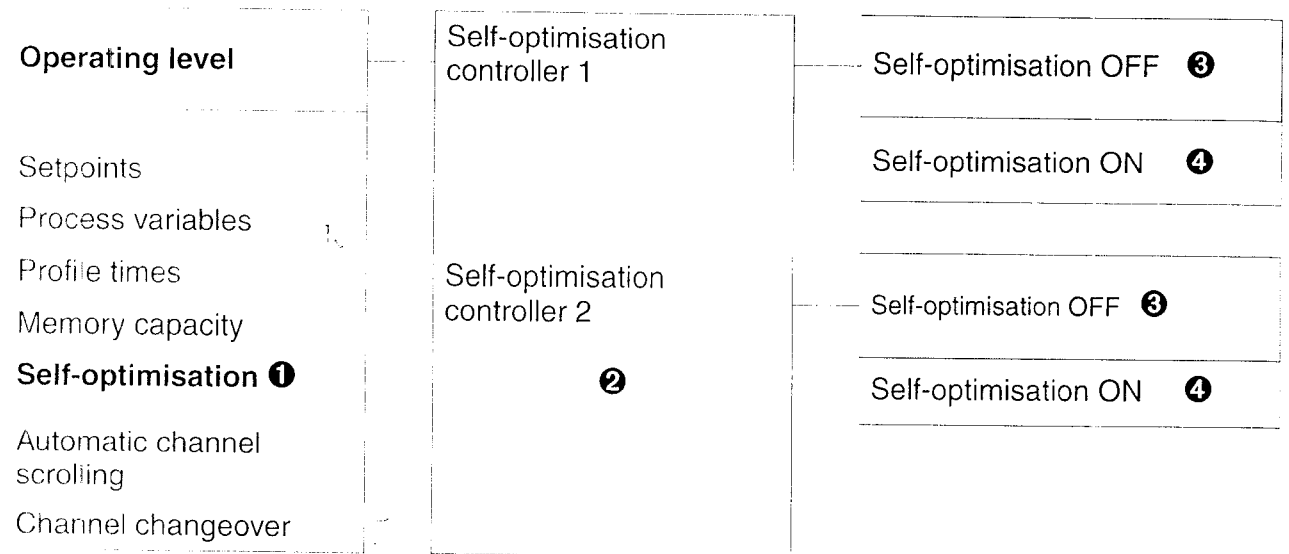

### Explanation:

\* = input a value

□ = factory setting

### Self-optimisation

No.	Item	Display	Notes
①	Self-optimisation	TUNE	↙ Section 15.2
②	Self-optimisation controller 1	TUNE C1	—
③	Self-optimisation OFF	TUNE C1 OFF	—
④	Self-optimisation ON	TUNE C1 ON	—

# 9 OPERATING LEVEL

## 9.7 Automatic channel scrolling

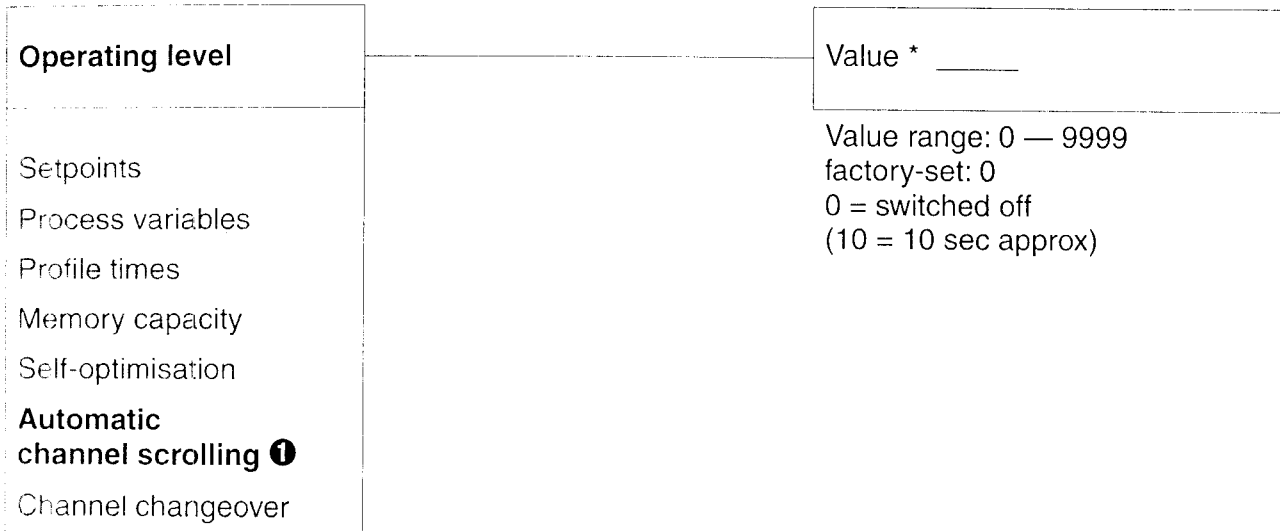

**Explanation:**

- \* = input a value
- = factory setting

**Automatic channel scrolling**

No.	Item	Display	Notes
①	Automatic channel scrolling	SCROLLMODE	Input of the time interval between the automatic display changeover from controller 1 to controller 2 and vice versa.

# 9 OPERATING LEVEL

## 9.8 Channel changeover

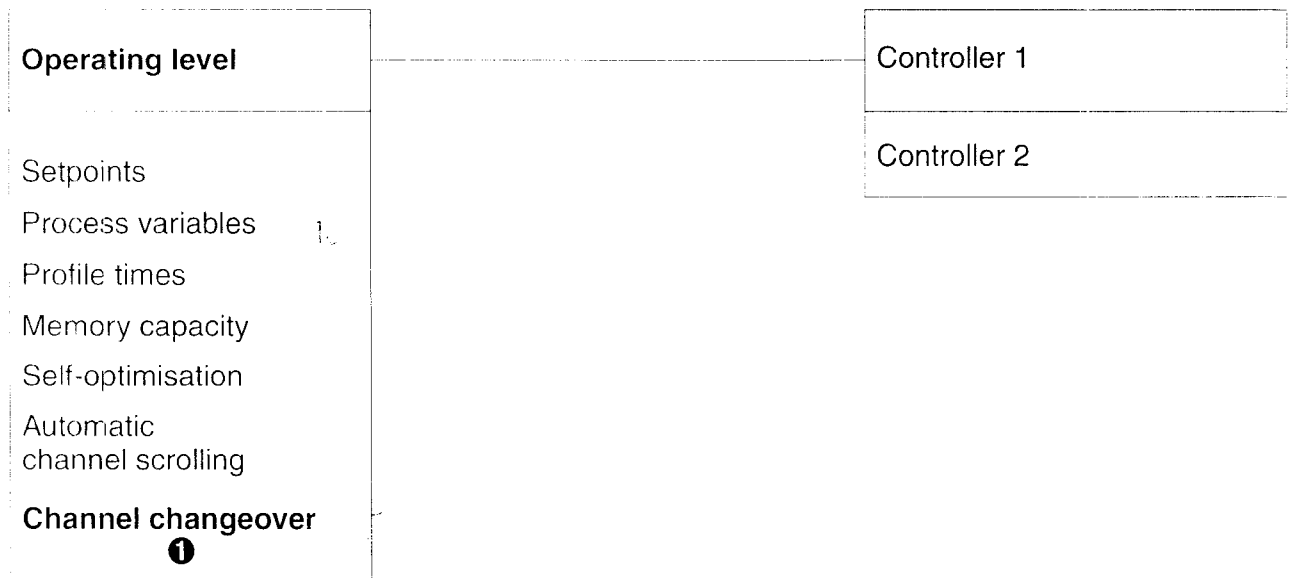

### Explanation:

- \* = input a value
- = factory setting

### Channel changeover

No.	Item	Display	Notes
①	Channel changeover	SWITCH CHANNEL	The process variables of the controllers (depending on configuration) are shown on the front displays. It is possible to switch over between displaying the process variables of the two controllers.

# 10 PARAMETER LEVEL

## 10.1 Overview

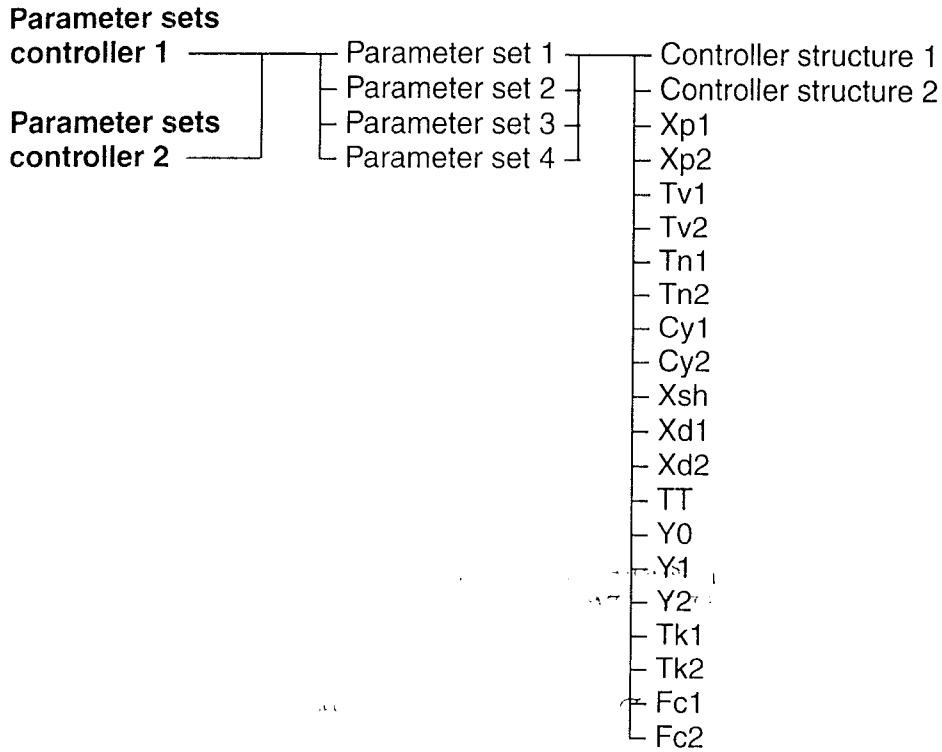

 Four parameter sets can be stored for each controller. The changeover is made through logic inputs.

 Configuration level C2:  
Logic inputs →  
Logic input 1 — 5  
Section 12.3

 Section 14.3

 Except for Y2, Fc2, all parameters with the index 2 (e.g. Xp2, Tv2) are relevant only for a double-setpoint controller (second output)

# 10 PARAMETER LEVEL

## 10.2 Parameter set

Parameter	Display	Value range	Factory setting	Explanation
Controller structure	STRUCTURE 1	P, I, PD, PI, PID	PID	The controller structure can be switched between P, I, PD, PI and PID structure. (Structure 2 refers to the second output on a double-setpoint controller)
	STRUCTURE 2	P, I, PD, PI, PID	PID	
Proportional band	PROPBD XP1	0 — 9999 digit	0 digit	Value of the proportional band. With Xp1, 2 = 0 the controller structure is ineffective!
	PROPBD XP2	0 — 9999 digit	0 digit	
Derivative time	DERIV TV1	0 — 9999 sec	80 sec	Influences the derivative component of the controller output signal.
	DERIV TV2	0 — 9999 sec	80 sec	
Reset time	RESET TN1	0 — 9999 sec	350 sec	Influences the integral component of the controller output signal.
	RESET TN2	0 — 9999 sec	350 sec	
Switching cycle time	CYCLE CY1	0 — 9999 sec	20 sec	In the case of a switching output the switching cycle time should be selected so that the energy supplied to the process is virtually continuous while the switching element is not stressed excessively.
	CYCLE CY2	0 — 9999 sec	20 sec	
Contact spacing	CT SEP XSH	0 — 999 digit	0 digit	Spacing between the two control contacts on double-setpoint controllers and modulating controllers.
Switching differential	DIFF XD1	0 — 999 digit	1 digit	Differential on switching controllers for Xp = 0.
	DIFF XD2	0 — 999 digit	1 digit	
Stroke time	STR TIM TT	5 — 3000 sec	60 sec	Actual stroke time range of the control valve on modulating controllers.
Working point	WORKPT Y0	-100 to +100 %	0 %	Output on P and PD controllers (y = Y0 at x = w).
Output limit	STR LIM Y1	0 — 100%	100 %	High output limit.
	STR LIM Y2	-100 to +100%	-100 %	Low output limit.
Minimum relay ON time	TIME REL1	0 — 60 sec	0 sec	Limit of switching frequency in the case of switching outputs.
	TIME REL2	0 — 60 sec	0 sec	
Fuzzy intensity	FZ INT FC1	0 — 100 %	0 %	Intensity of the fuzzy signal added to controller output to improve control quality.
Fuzzy parameter adjustment	FZ PAR FC2	0 — 100 %	30 %	Influence on the controller parameters through activated fuzzy module to improve control quality.

# 11 CONFIGURATION LEVEL C1

## 11.1 Overview

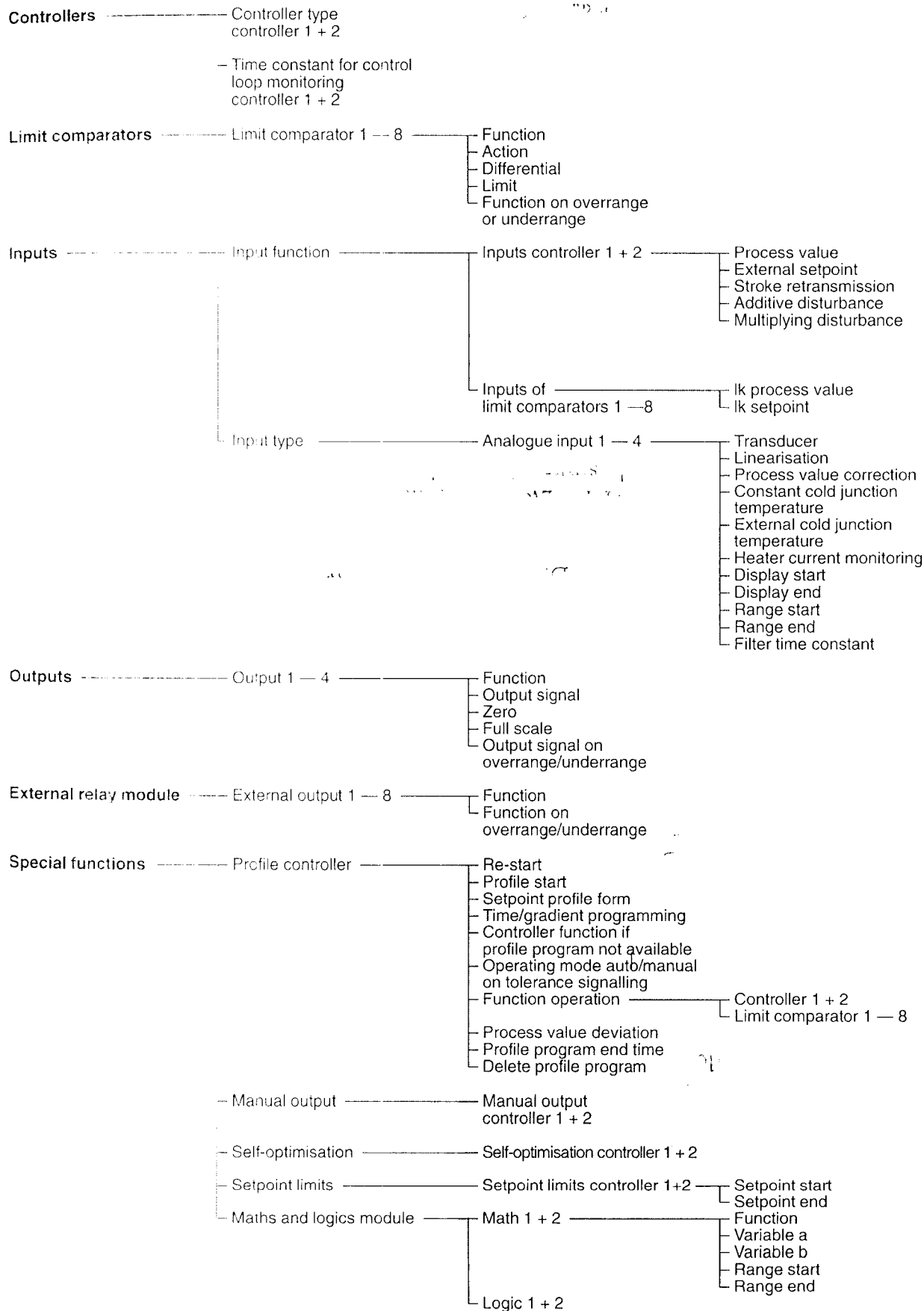

# 11 CONFIGURATION LEVEL C1

## 11.2 Controllers

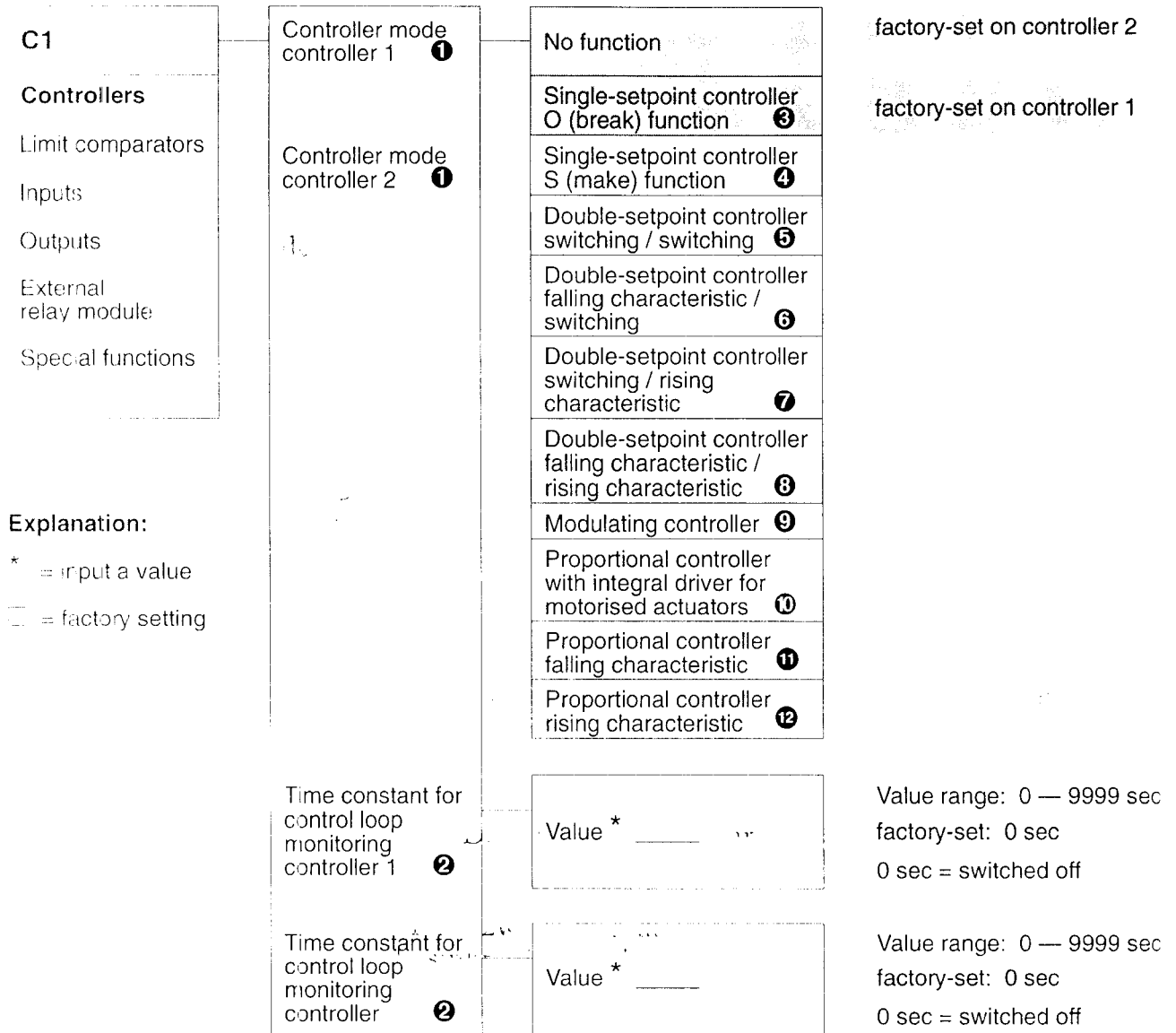

1 "No function" not possible for controller mode controller 1

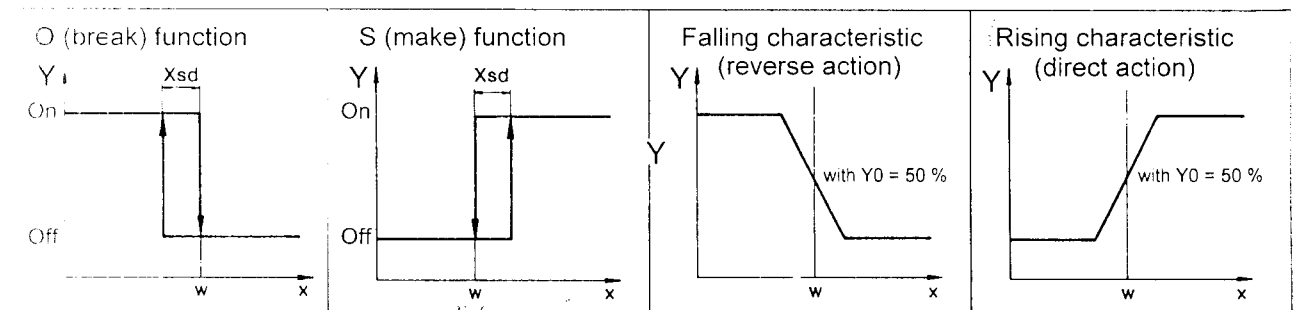

### Controller functions



Y = control output, w = setpoint, x = process value, X<sub>Sd</sub> = switching differential

# 11 CONFIGURATION LEVEL C1

## Controller

No.	Item	Display	Notes
①	Mode controller X	CONTROLR MODE CX	Function of controller(s)
②	Time constant for control loop monitoring controller X	MON TIM CX	Monitors the process value. An error is recognised if it does not follow the controller output signal within a programmed time period. The time constant must be selected to suit the control loop.
③	Single-setpoint controller O (break) function	1-SETPT FUNCT. O	Relay de-energised for process above setpoint
④	Single-setpoint controller S (make) function	1-SETPT FUNCT. S	Relay de-energised for process below setpoint
⑤	Double-setpoint controller switching / switching	2-SETPT SWITCHG	Two relay or logic outputs
⑥	Double-setpoint controller falling characteristic / switching	2-SETPT FALL/SWG	One analogue output and one relay or logic output
⑦	Double-setpoint controller switching / rising characteristic	2-SETPT SWG/RISG	One relay or logic output and one analogue output
⑧	Double-setpoint controller falling / rising characteristic	2-SETPT FALL/RISG	Two analogue outputs  ⑪ and ⑫
⑨	Modulating controller	MODULATING	—
⑩	Proportional controller with integral driver for motorised actuators	ACTUATOR DRIVER	 Configuration level C1: Inputs → Function → Inputs controller 1 + 2 → Stroke retransmission Section 11.4   Section 17.7
⑪	Proportional controller falling characteristic (reverse action)	PROP.CONTR.FALL	Output Y reduces as process value X increases
⑫	Proportional controller rising characteristic (direct action)	PROP.CONTR.RISG	Output Y increases as process value X increases

# 11 CONFIGURATION LEVEL C1

## 11.3 Limit comparators

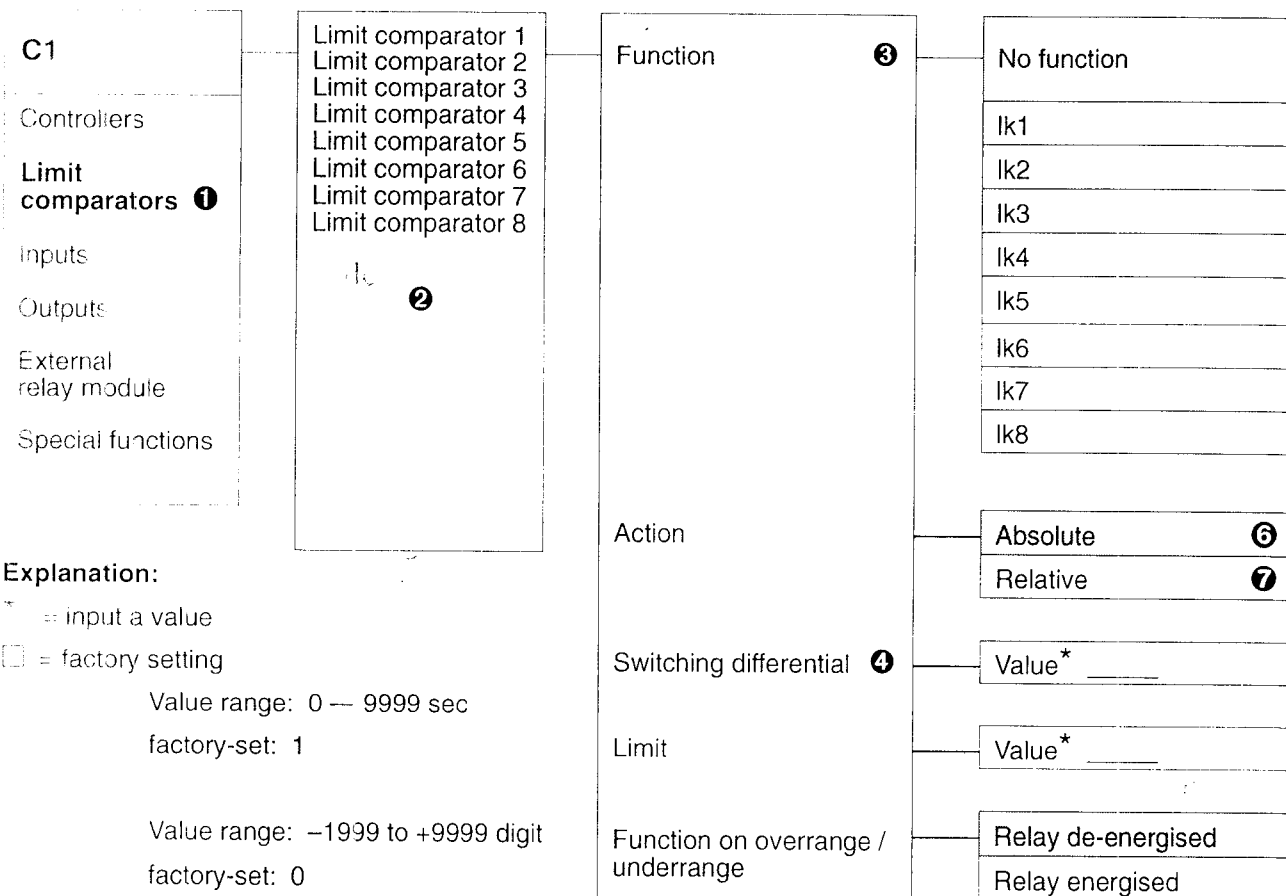

### Explanation:

\* = input a value

□ = factory setting

Value range: 0 — 9999 sec

factory-set: 1

Value range: -1999 to +9999 digit

factory-set: 0

### Limit comparator functions

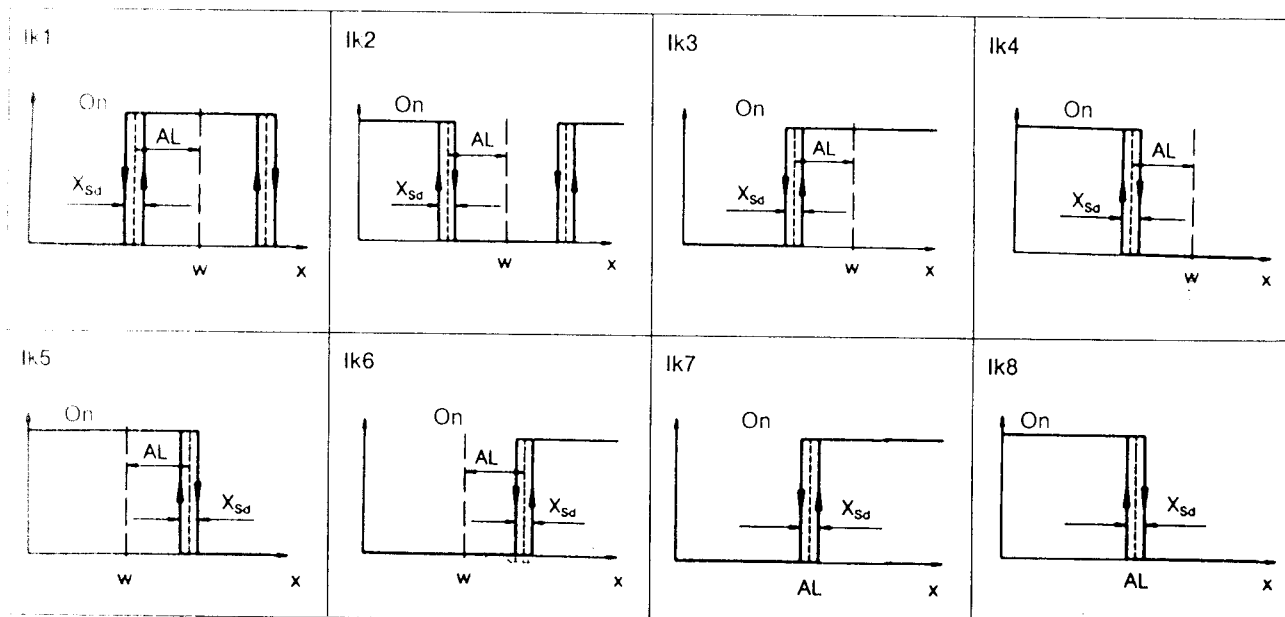

AL = limit,  $X_{sd}$  = switching differential, w = setpoint, x = process value

# 11 CONFIGURATION LEVEL C1

## Limit comparators

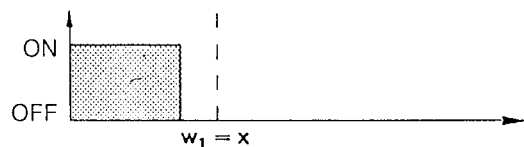
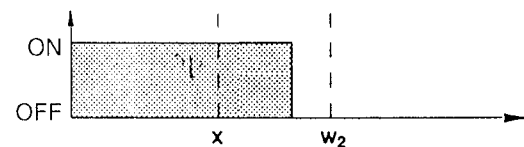
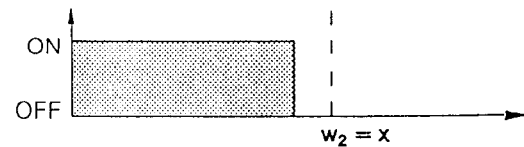
No.	Item	Display	Notes
①	Limit comparators	LIMIT COMPARATOR	 Section 19.2  The settings "absolute" and "relative" determine the action of the limit comparators for an alteration of the limit (AL) or in the (limit comparator) setpoint.  <b>Absolute:</b> At the time of the alteration the limit comparator acts according to its function.  <b>Relative:</b> The limit comparator is in the OFF status. If an alteration of the limit or of the (limit comparator) setpoint would cause the limit comparator to switch ON, this reaction is suppressed. This status is retained until the (limit comparator) actual value has <b>moved away</b> from the switch-on region (grey area).  Example: Monitoring the (controller) process value $x$ with Ik4. Setpoint alteration $w_1 \rightarrow w_2$  a) Initial status   b) Status at the time of the alteration. The limit comparator remains on OFF although the process value is within the switch-on region   c) Control stabilised. The limit comparator again operates according to its function 
②	Limit comparator 1	LIM.COMPARATOR 1	
③	Function	LIMCOMP FUNCTION	
④	Switching differential	DIFFERENTIAL	
⑤	Function on over-range / underrange	RANGE FUNC	
⑥	Absolute	ABSOLUTE	
⑦	Relative	RELATIVE	



When a limit comparator is switched to an output, the output setting "Function on overrange/underrange" has priority.



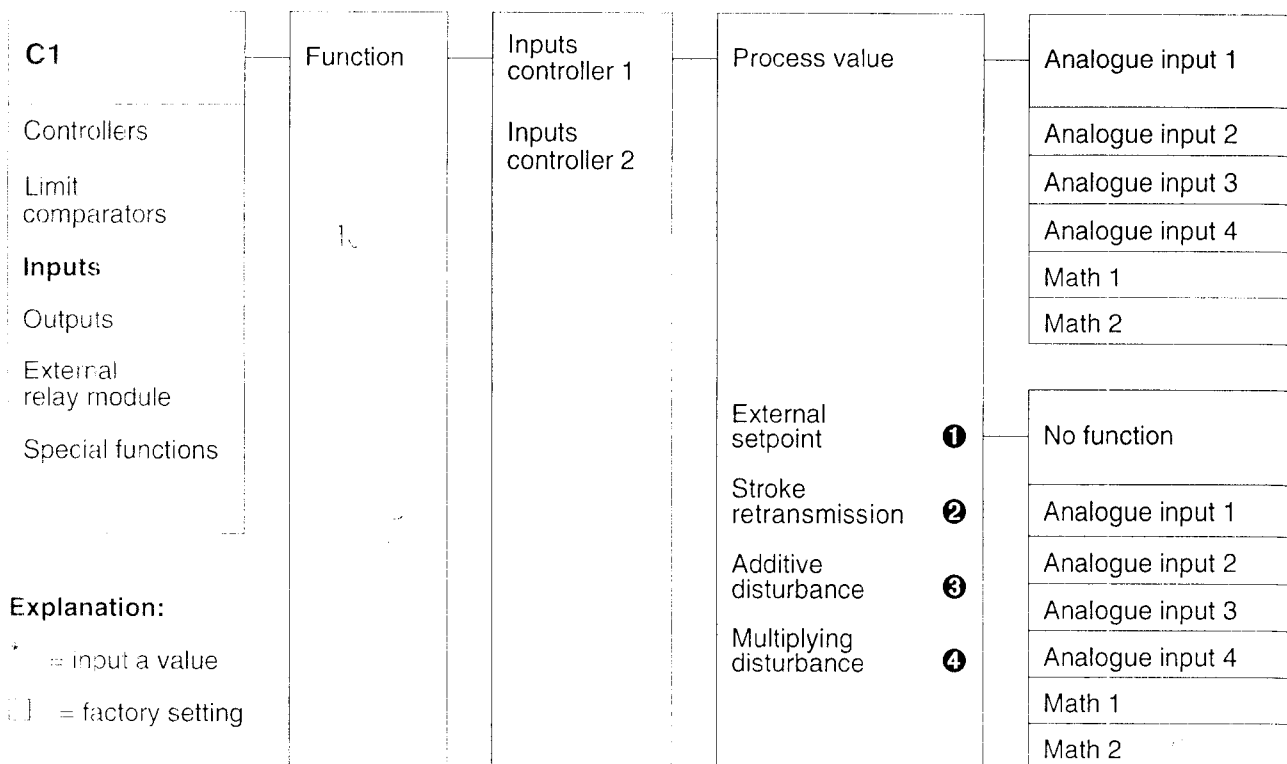

 Section 11.5, 11.6

# 11 CONFIGURATION LEVEL C1

## 11.4 Inputs



### Inputs

No.	Item	Display	Notes
①	External setpoint	EXT SETPOINT	An external setpoint is input via an analogue input or a maths function. The external setpoint corresponds to setpoint 1 at the operating level.
②	Stroke retransmission	STROKE RETRANSM.	 Configuration level C1: Controllers → Controller mode → Function → Controller with integral driver for motorised actuators Section 17.7
③	Additive disturbance	ADD. DISTURBANCE	 Section 17.8
④	Multiplying disturbance	MULT.DISTURBANCE	 Not available on modulating controller   Section 17.9

# 11 CONFIGURATION LEVEL C1

## Inputs

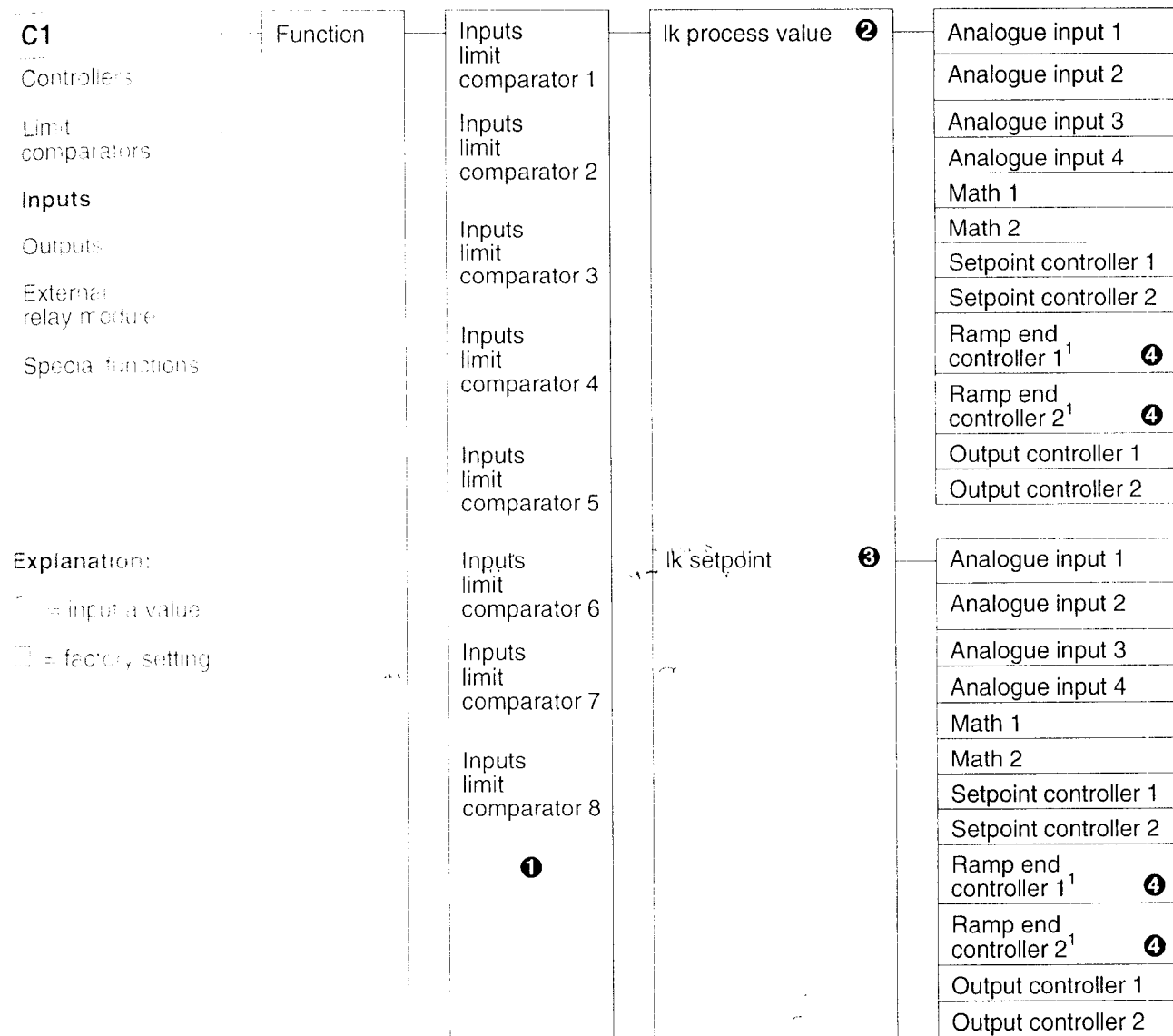

## Inputs

No.	Item	Display	Notes
<b>1</b>	Inputs limit comparator 1	INPUTS LC1	—
<b>2</b>	Process value	LC ACTUAL VALUE	—
<b>3</b>	Setpoint	LC SETTING	—
<b>4</b>	Ramp end controller 1	RAMP END C1	—



# 11 CONFIGURATION LEVEL C1

## Inputs

No.	Item	Display	Notes									
①	Process value correction	OFFSET	<p>Using the process value correction a measured value can be corrected upwards or downwards by a certain amount.</p> <p>Examples:</p> <table data-bbox="794 589 1238 730"> <tr> <td>measured value</td> <td>offset</td> <td>indicated value</td> </tr> <tr> <td>294.7</td> <td>+0.3</td> <td>295.0</td> </tr> <tr> <td>295.3</td> <td>-0.3</td> <td>295.0</td> </tr> </table> <p> The controller uses the corrected (= indicated) value for its calculation . This value does not correspond to the actually measured value. With inappropriate use it is possible to produce prohibited values of the controller output.</p>	measured value	offset	indicated value	294.7	+0.3	295.0	295.3	-0.3	295.0
measured value	offset	indicated value										
294.7	+0.3	295.0										
295.3	-0.3	295.0										
②	Constant cold junction temperature	CJ TEMP.	Temperature of the cold junction thermostat.									
③	External cold junction temperature	EXT.CJ TEMP.	Measurement of cold junction temperature with a temperature probe.									
④	Heater current monitoring	HEATER CURNT MON	<p>The heater current is evaluated using a current transformer with a standard output signal; it can be monitored by linking the analogue input to a limit comparator.</p> <p>The measurement is always made when the heating contact is closed.</p> <p>The measured value is retained until the next measurement.</p>									

# 11 CONFIGURATION LEVEL C1

## Inputs

No.	Item	Display	Notes
5	Display start	DISPLSTART	On transducers with standard signal and also on resistance transmitters an indicated value is assigned to the actual signal; example: 0 — 20 mA = 0 — 1500 °C. The actual signal can go 20% above or below its range without initiating an alarm.
6	Display end	DISPL.END	
7	Range start	RANGESTART	The measuring range of the transducers can be restricted for monitoring. Going above or below the limits (range start, range end) results in an alarm.  Example: Pt 100 (measuring range: -200 to +850 °C) An alarm message is required outside the range 15 to 200 °C. → range start: 15 range end: 200
8	Range end	RANGE END	
9	Filter time constant	FILTER TIM	To adjust the digital input filter to disturbances in the input signal.
10	Resistance thermometer	RESISTANCE	Pt 100 resistance thermometer in 2-wire or 3-wire circuit.
11	Thermocouple internal cold junction	TC INTERNAL CJ	Determining the cold junction temperature using an internal Pt 100. The cold junction is at the terminals on the back panel.
12	Thermocouple external cold junction	TC EXTERNAL CJ	Measurement of the cold junction temperature using a temperature probe.
13	Thermocouple constant cold junction	TC CONSTANT CJ	Maintaining a constant cold junction temperature using an external cold junction thermostat.
14	Resistance transmitter	RETRANSMITTER	Potentiometer with 3-wire connection (100 Ω min, 10 kΩ max.)
15	Customized linearisation 1	SPECIAL LIN.1	20 calibration points max. Only available with setup program.  Description see Online-Help

# 11 CONFIGURATION LEVEL C1

## 11.5 Outputs

C1	Output 1	Function	No function <sup>2</sup>
	Output 2 <sup>1</sup>		Output 1 controller 1 <sup>3</sup>
Controller:	Output 3	①	Output 2 controller 1
	Output 4		Output 1 controller 2
Limit comparators			Output 2 controller 2
			Output limit comparator 1
Inputs			Output limit comparator 2
			Output limit comparator 3
Outputs			Output limit comparator 4
			Output limit comparator 5
External relay module			Output limit comparator 6
			Output limit comparator 7
Special functions			Output limit comparator 8
			Operating contact 1
Explanation:			Operating contact 2
			Operating contact 3
* = input a value			Operating contact 4
□ = factory-set			Operating contact 5
			Operating contact 6
			Operating contact 7
			Operating contact 8
			Profile end signal ②
			Tolerance signal ③
			Logic 1
			Logic 2
			Math 1 <sup>4</sup>
			Math 2 <sup>4</sup>
			Analogue input 1 <sup>4</sup>
			Analogue input 2 <sup>4</sup>
			Analogue input 3 <sup>4</sup>
			Analogue input 4 <sup>4</sup>
			Setpoint controller 1 <sup>4</sup>
			Setpoint controller 2 <sup>4</sup>
			Deviation controller 1 <sup>4</sup>
			Deviation controller 2 <sup>4</sup>

1. Always switching output
2. Factory-set on output 2 – 4
3. Factory-set on output 1
4. Not on output 2

# 11 CONFIGURATION LEVEL C1

## Outputs



No.	Item	Display	Notes
①	Function	OUTPUT FUNCTION	—
②	Profile end signal	PROGRAM END SIG	Output signals the end of the profile program (profile 1 and 2). The signal duration can be programmed.  Section 11.7 (profile controller)
③	Tolerance signal	TOLERAN.BAND SIG	Output signals above or below tolerance limits. The tolerances can be defined separately for each segment of a profile program (profile program editor).

# 11 CONFIGURATION LEVEL C1

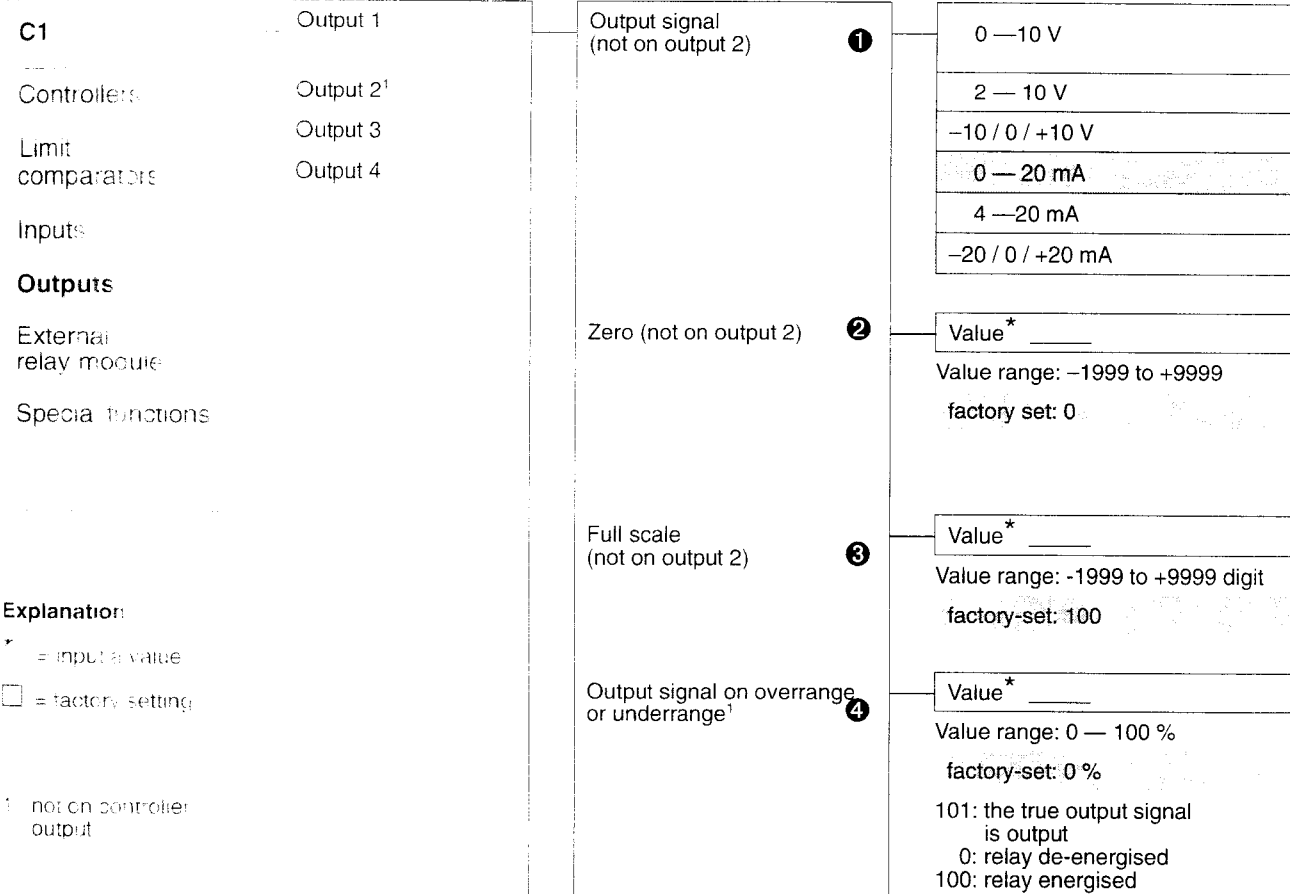
## Outputs





## Outputs

No.	Item	Display	Notes
❶	Signal	OUTPUT SIGNAL	—
❷	Zero		A range of values is assigned to a physical output signal; e.g. 0 — 20mA = 150 — 500 °C   Control output on proportional controllers with rising characteristic (direct action): zero = 0 full scale: -100
❸	Full scale		
❹	Output signal on overrange or underrange	RANGE FUNC	The output carries a defined signal.   If the output is a controller output, the controller switches over to manual operation and outputs a defined control output.



# 11 CONFIGURATION LEVEL C1

## External relay module

No.	Item	Display	Notes
①	External relay module	RELAY MODULE	External relay module ER8 with eight relays.  Section 16.1
②	External output 1	EXTERNAL OUT 1	—
③	Function	OUTPUT FUNCTION	—
④	Function on overrange or underrange	RANGE FUNC	 If the external output is a controller output the controller switches over to manual operation and outputs a defined control output (0 / 100 %)
⑤	Output 1 controller 1	OUTPUT 1 C1	—
⑥	Output limit comparator 1	OUTPUT LC 1	—
⑦	Profile end signal	PROGRAM END SIG	The output signals the end of the profile program (profile 1 and 2). The duration of the signal can be programmed.  Section 11.7 (profile program editor)
⑧	Tolerance signal	TOLERAN.BAND SIG	The output indicates signal above or below tolerance limits. The tolerances can be defined separately for each segment of a profile (profile program editor).

# 11 CONFIGURATION LEVEL C1

## 11.7 Special functions

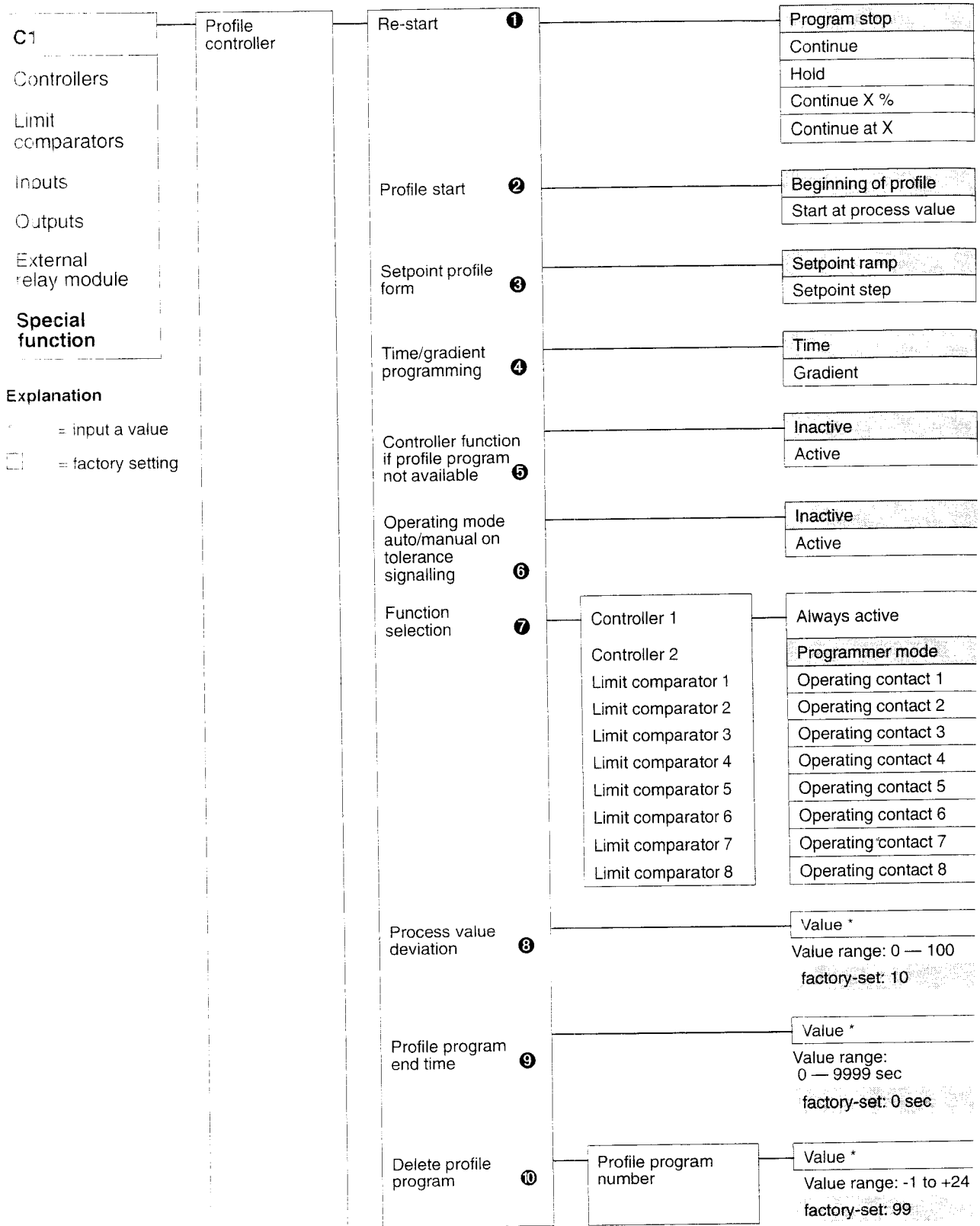



**Explanation**

- = input a value
- = factory setting

# 11 CONFIGURATION LEVEL C1

## Special functions

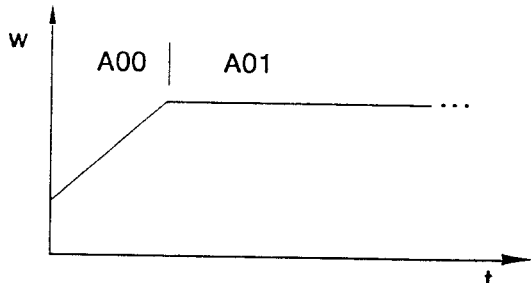
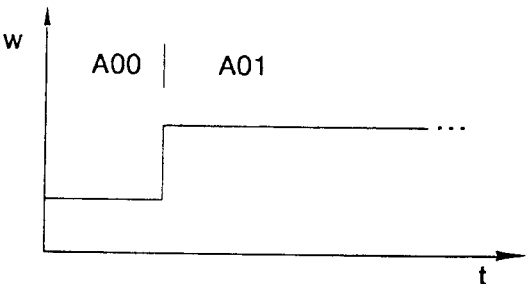
No. Item	Display	Notes
① Re-start	RESTART	Action of controller on supply failure  Section 19.5  Process value deviation (= X %)
② Profile start	PROGRAM START	Start conditions for the start of profile programs: – Beginning of profile Profile program starts with the programmed setpoint of segment A00  – Start at process value The current process value is taken as the first setpoint.
③ Setpoint profile form	SETP SELECTION	Setpoint ramp:   Setpoint step: 

# 11 CONFIGURATION LEVEL C1

## Special functions

No.	Item	Display	Notes
4	Time/gradient programming	TIME/GRAD-PROGR	This determines how segments are programmed when creating profile programs (profile program editor): – time setpoint/segment time  – gradient setpoint/gradient
5	Controller function if profile program not available	CTR FCT W/O PRG	inactive: controller switches off all outputs  active: controller controls to the setpoint of the basic status (can only be selected via setup program).
6	Operating mode auto/manual on tolerance signal	TOL. AUTOHAND	If the process value goes beyond the defined tolerance band, the profile controller changes to the auto-manual operating mode. When the process value returns to within the tolerances, the profile program continues.
7	Function selection	MON.FUNCTION	This defines when controllers and limit comparators are active.  Programmer mode: active only in operating mode auto  Operating contact: active only when operating contact is ON
8	Process value deviation	DEVIATION	Relevant for re-start (continue X %)
9	Profile program end time	ENDTIME	Duration of profile end signal at outputs.
10	Delete profile program	DELETE PROGRAM	0 — 24 = delete the corresponding profile program -1 = delete all profile programs

# 11 CONFIGURATION LEVEL C1

## Special functions

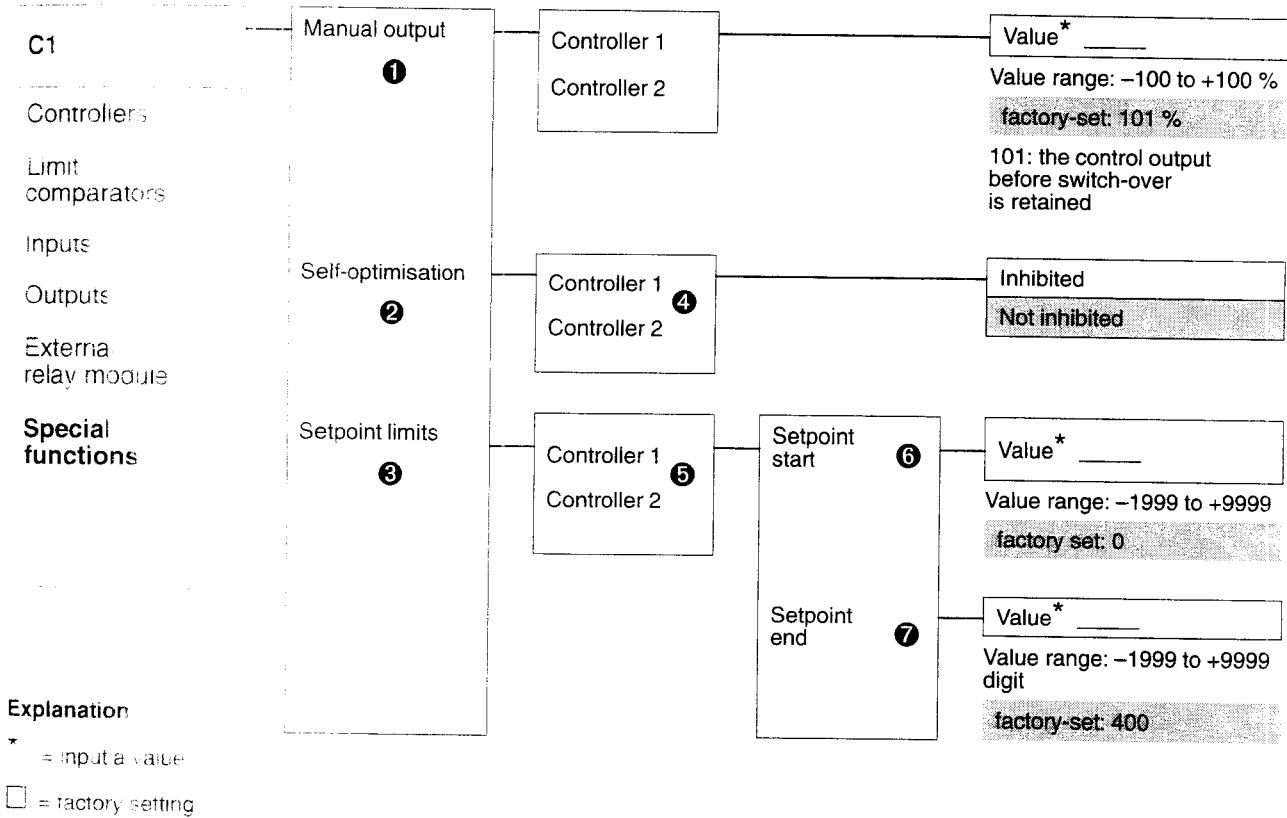





No.	Item	Display	Notes
<b>1</b>	Manual output	MANUAL OUTPUT	Value used as actual control output on changeover to manual operation.
<b>2</b>	Self-optimisation	INHIBIT TUNE	Self-optimisation can be inhibited.
<b>3</b>	Setpoint limits	SETPOINT LIMITS	The range of setpoint values can be restricted here.
<b>4</b>	Controller 1	TUNE C1	—
<b>5</b>	Controller 1	SETPOINT LIM. C1	—
<b>6</b>	Setpoint start	SETPT STRT	Limits within which setpoints have to be specified.
<b>7</b>	Setpoint end	SETPT END	



# 11 CONFIGURATION LEVEL C1

## Special functions

No.	Item	Display	Notes
11	Range start	RANGESTART	Setting a range of values for the result of a mathematical calculation. An alarm message is produced if the result is outside this range.
12	Range end	RANGE END	
13	Difference (a-b)	DIFFERENCE (A-B)	 Sections 16.3, 17.12
14	Ratio (a/b)	RATIO (A/B)	<p>The control is always referred to variable a. The maths module forms the ratio of the values of a and b (a/b) and provides the setpoint for the controller. The ratio of the measured values a and b can be called up and displayed using the function "Math 1" or "Math 2".</p> <p>The required ratio a/b is programmed as setpoint (ratio setpoint) in the setpoint setting.</p> <p> Math 1 provides the setpoint for controller 1 Math 2 provides the setpoint for controller 2</p> <p> Section 17.5</p>
15	Humidity (a:b)	HUMIDITY	<p>a – dry bulb temperature b – wet bulb temperature</p> <p> Section 17.6</p>
16	Math formula	MATH FORMULA	Can only be input using the setup program.   Sections 16.3, 16.4, 17.12
17	Logic formula	LOGIC FORMULA	

# 12 CONFIGURATION LEVEL C2

## 12.1 Overview

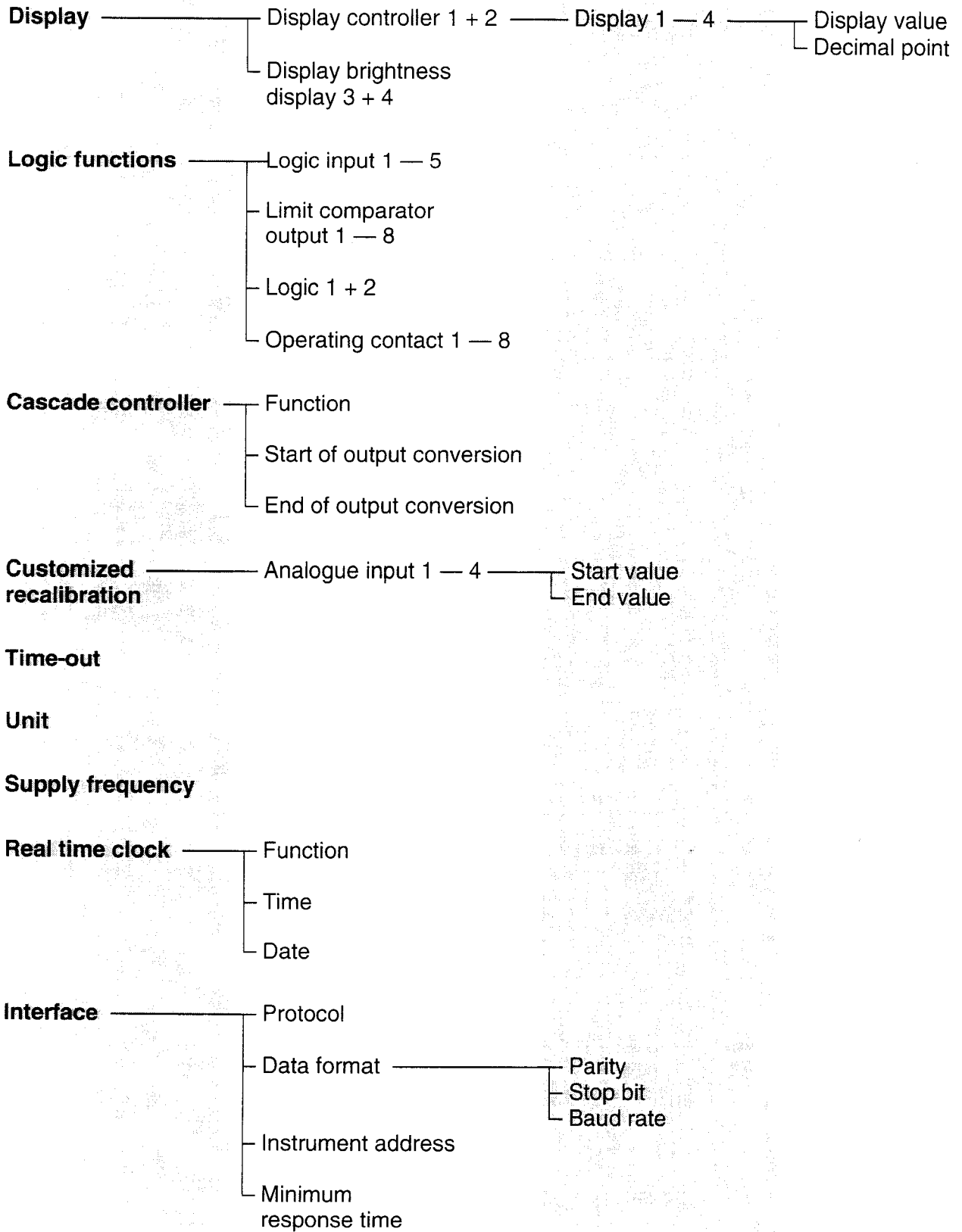

# 12 CONFIGURATION LEVEL C2

## 12.2 Display

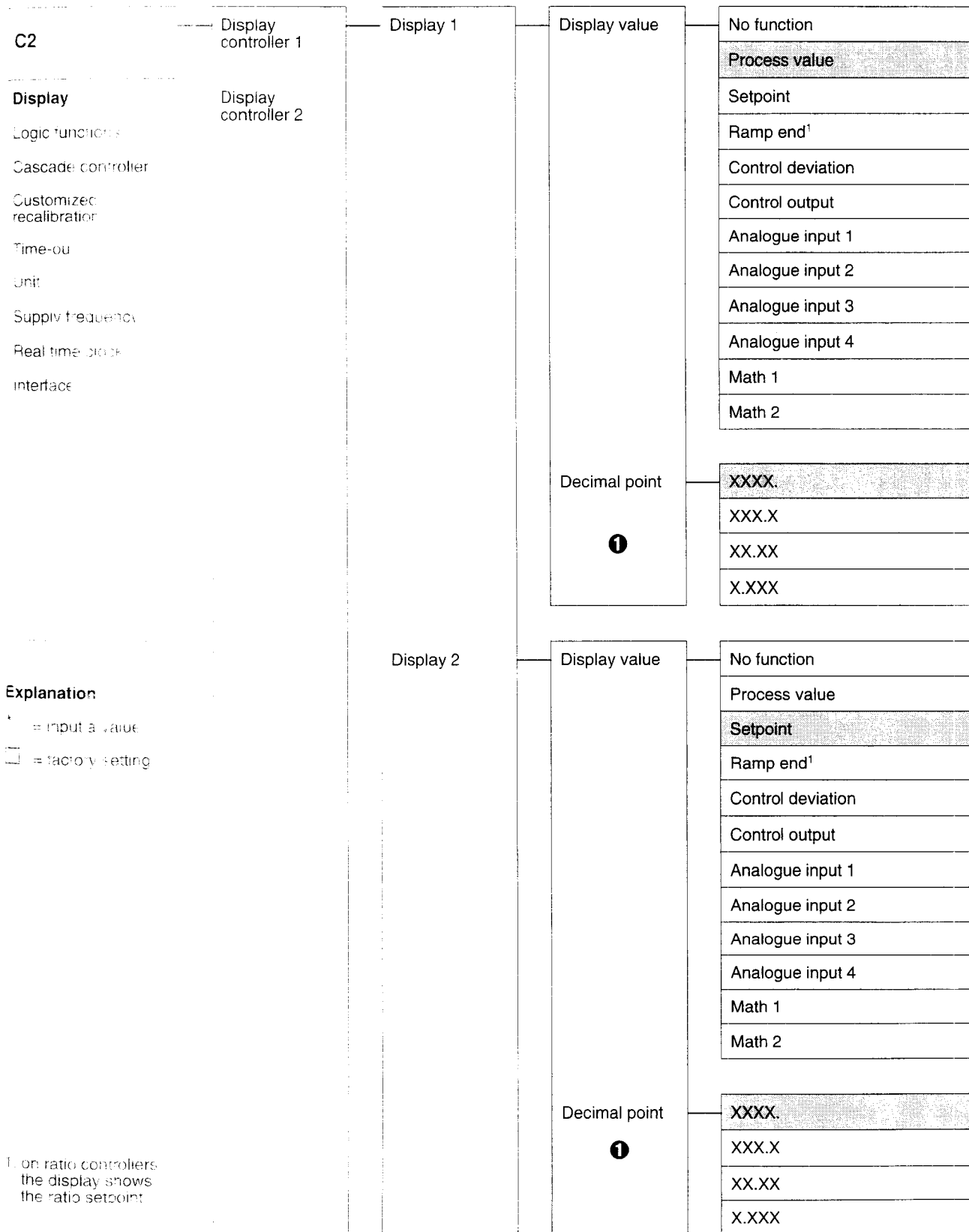

# 12 CONFIGURATION LEVEL C2

## Display

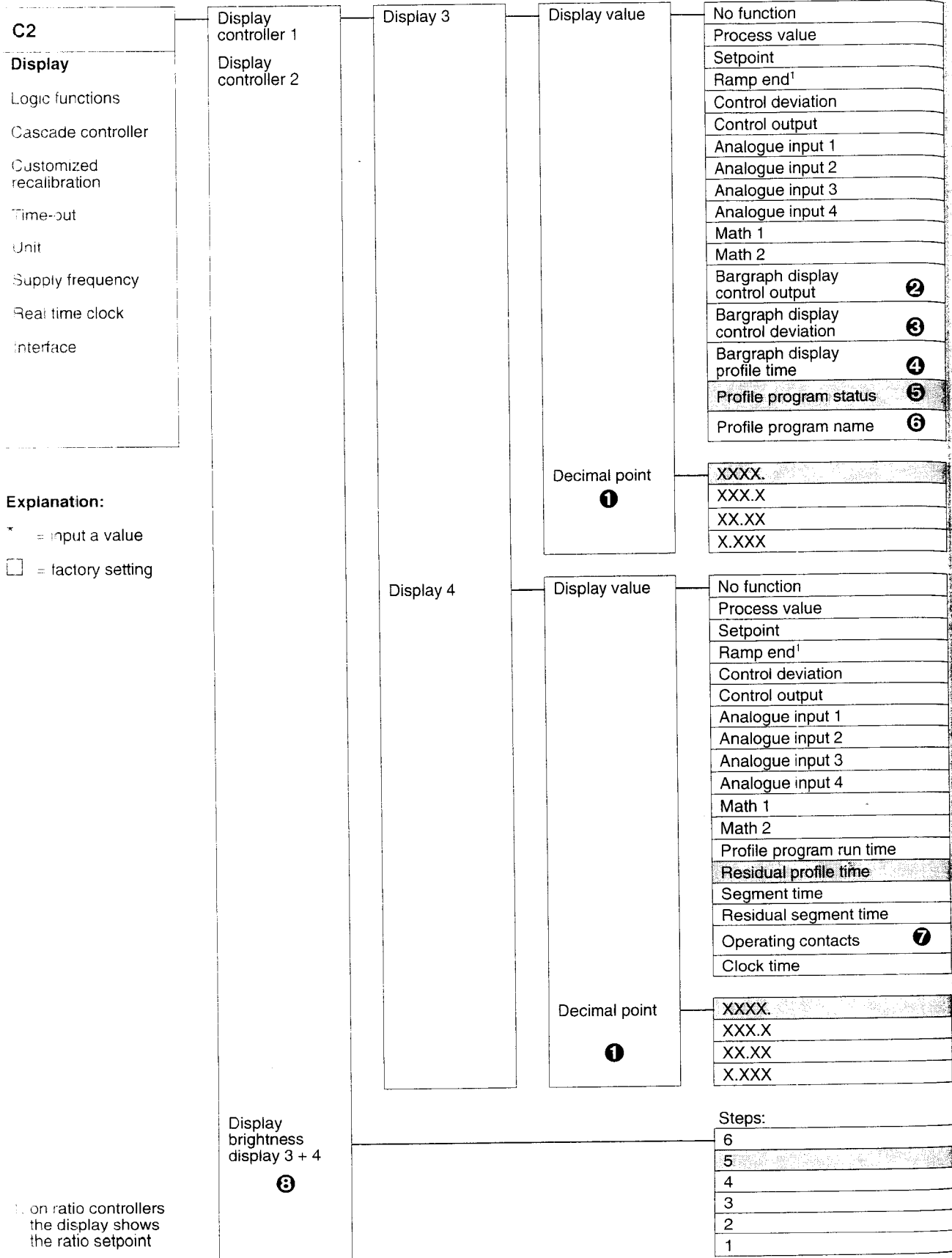

1. on ratio controllers the display shows the ratio setpoint

## 12 CONFIGURATION LEVEL C2

### Displays

No.	Item	Display	Notes
①	Decimal point	DECIMAL POINT	If the value to be displayed can no longer be shown with the programmed decimal places, the number of decimal places is automatically reduced. If the measured value later reduces again, the number of decimal places is increased up to the programmed number.
②	Bargraph display control output	BARGRAPH OUTPUT	Single-setpoint controller:  0 %                      100 % □ □ □ □ □ □ □ □ □ □  Resolution: 2 % / division  Double-setpoint controller:  -100 %   0            100 % □ □ □ □ □ □ □ □ □ □  Resolution: 4 % / division
③	Bargraph display control deviation	BARGR. DEVIATION	-50            0            +50 □ □ □ □ □ □ □ □ □ □  Resolution: 2 digit/division
④	Bargraph display profile time	BARGR: PGM TIME	□   _ _ _ _ _ _ _ _  The indication is in percent of the elapsed profile run time. Resolution: 2 % / division  Times can not be shown on display 4.
⑤	Profile program status	PROGRAM STATUS	Indication of profile program and segment number (PXX / AXX).
⑥	Profile program name	PROGRAM NAME	Names (16 characters max.) can be assigned to the profile program via the setup program (accessory). The name of the current profile program is indicated.
⑦	Operating contacts	OPER.CONTACTS	The status of the eight operating contacts is indicated.  Operating contact 1 2 3 4 5 6 7 8 1 0 0 0 0 0 0 0  1 = ON, 0 = OFF
⑧	Display brightness display 3 + 4	BRIGHTNESS	—

# 12 CONFIGURATION LEVEL C2

## 12.3 Logic inputs

<b>C2</b>  Display  <b>Logic functions</b>  Cascade controller  Customized recalibration  Time-out  Unit  Supply frequency  Real time clock  Interface	Logic input 1 Logic input 2 Logic input 3 Logic input 4 Logic input 5  <div style="text-align: center;"><b>1</b></div>	No function  Start of self-optimisation controller 1 <b>3</b> Start of self-optimisation controller 2 <b>3</b> Aborting self-optimisation controller 1 <b>4</b> Aborting self-optimisation controller 2 <b>4</b> Setpoint changeover controller 1 <b>5</b> Setpoint changeover controller 2 <b>5</b> Process value changeover controller 1 <b>6</b> Process value changeover controller 2 <b>6</b> Parameter set switch-over controller 1 <b>7</b> Parameter set switch-over controller 2 <b>7</b> Key inhibit <b>8</b> Parameter and configuration levels inhibit <b>9</b> Text display <b>10</b> All displays OFF <sup>1</sup> <b>11</b> Auto / manual changeover <b>12</b> Profile program editor inhibit <b>13</b> Profile program start <b>14</b> Profile program stop <b>15</b> Profile program abort <b>16</b> Fast forward <b>17</b> Text display <b>18</b>
	Limit comparator 1 output Limit comparator 2 output Limit comparator 3 output Limit comparator 4 output Limit comparator 5 output Limit comparator 6 output Limit comparator 7 output Limit comparator 8 output  <div style="text-align: center;"><b>2</b></div>	
	Logic 1 Logic 2 Operating contact 1 Operating contact 2 Operating contact 3 Operating contact 4 Operating contact 5 Operating contact 6 Operating contact 7 Operating contact 8	

**Explanation:**

- \* = input a value
- = factory setting

Incl. LEDs

## 12 CONFIGURATION LEVEL C2

### Logic inputs

No.	Item	Display	Notes
①	Logic input 1	LOGIC INPUT 1	—
②	Limit comparator 1 output	OUTPUT LC 1	—
③	Start of self-optimisation controller 1	START TUNE C1	 Section 14.1
④	Aborting self-optimisation controller 1	ABORT TUNE C1	
⑤	Setpoint changeover controller 1	SETPT SWITCH C1	
⑥	Process value changeover controller 1	PROCVAL.SWITCHC1	
⑦	Parameter set switch-over controller 1	PARSET SWITCH C1	
⑧	Key inhibit	KEYS INHIBIT	
⑨	Parameter and configuration levels inhibit	MENU INHIBIT	
⑩	Text display	TEXT DISPLAY	
⑪	All displays off	DISPLAYS OFF	
⑫	Auto / manual changeover	AUTO/MAN. SWITCH	
⑬	Profile program editor inhibit	PGM INHIBITION	
⑭	Profile program start	PROGRAM START	
⑮	Profile program stop	PROGRAM STOP	
⑯	Profile program abort	PROGRAM ABORT	
⑰	Fast forward	FAST FORWARD	
⑱	Profile program selection	PROGRAM SELECT.	

# 12 CONFIGURATION LEVEL C2

## 12.4 Cascade controller

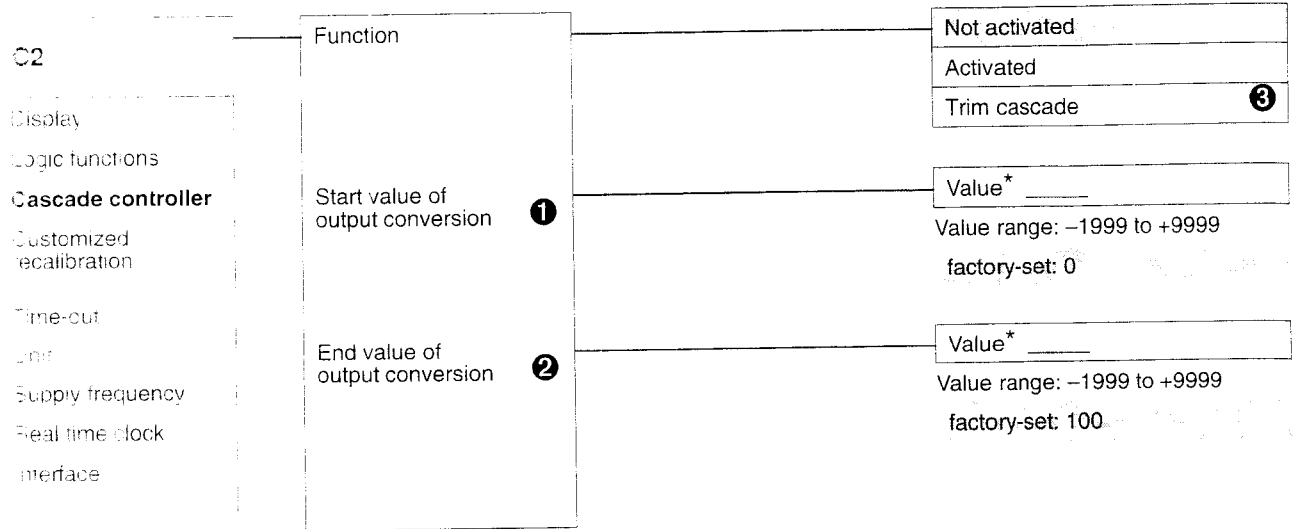

**Explanation:**

- ① = input a value
- ② = factory setting

Controller 1: master controller  
 Controller 2: slave controller

**Cascade controller**

No.	Item	Display	Notes
①	Start value of output conversion	OUTPUT ST.	➔ Section 17.2
②	End value of output conversion	OUTPUT END	
③	Trim cascade	TRIM CASCADE	➔ Section 17.3

# 12 CONFIGURATION LEVEL C2

## 12.5 Customized recalibration

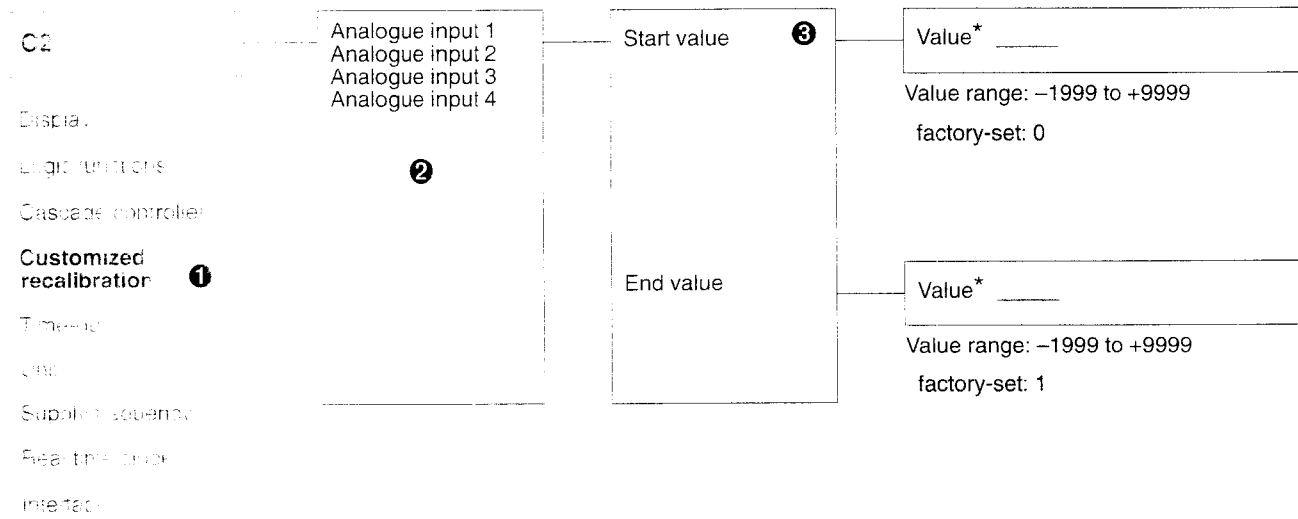

**Explanation:**

- \* = input value
- = factory setting

### Customized recalibration

No.	Item	Display	Notes
①	Customized recalibration	RECALIBRATION	Description on the next two pages.
②	Analogue input X	CORRECTION INP.1	—
③	Start value	STRT VALUE	—

# 12 CONFIGURATION LEVEL C2

## Customized recalibration

Through the analogue inputs of the controller a signal is processed electronically (conversion, linearisation ...) to produce a measured value. This measured value enters into the calculations of the controller and can be shown on the display (measured value = indicated value).

This fixed relationship can be modified if required. i.e. the position and the slope of the measured value characteristic can be altered.

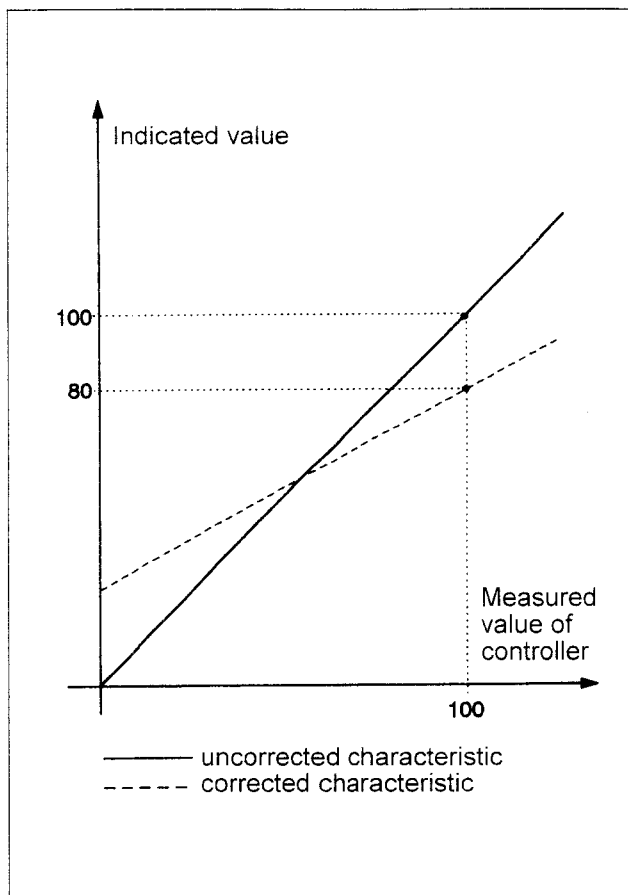

### Procedure:

Apply two measurement points ( ❶ , ❸ ) to the controller; they should be as far apart as possible.

At these measurements input the required indication value (start value, end value) to the controller. A reference measuring instrument is most convenient for determining the measured values M1 and M2.

Measurement conditions must remain stable during programming.

### Programming:

- \* Move to measurement point ❶
- \* Input start value S ❷

↙ Configuration level C2:  
Customized recalibration →  
analogue input 1 — 4 → start value

- \* Move to measurement point ❸
- \* input end value E ❹

↙ Configuration level C2:  
Customized recalibration →  
analogue input 1 — 4 → end value

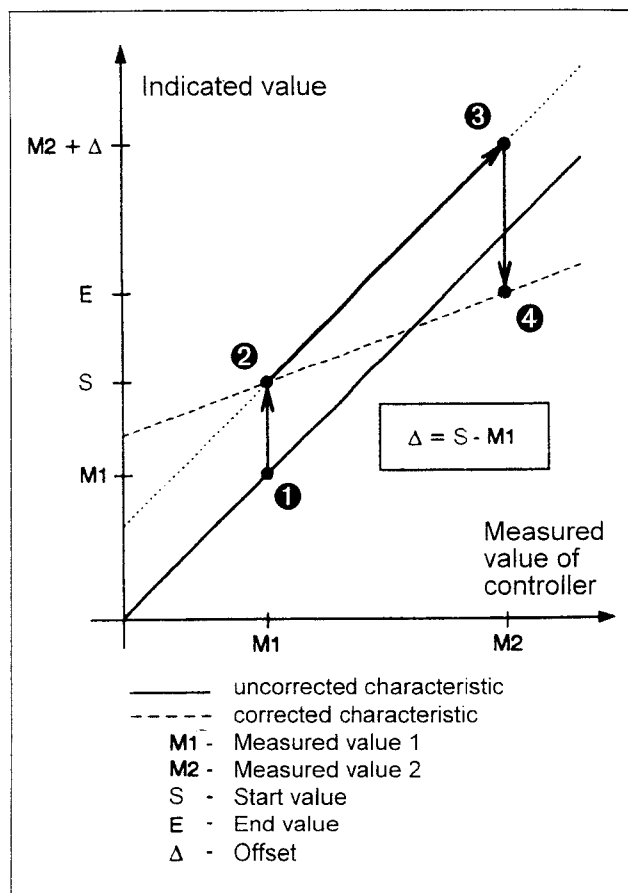

## 12 CONFIGURATION LEVEL C2

---



If recalibration is performed using the controller alone (without a measuring instrument) the offset  $\Delta$  must be taken into account when moving to measuring point ③.

Recalibration can be cancelled by programming the start value and end value to the same value. This sets the start value to 0 and the end value to 1.

Otherwise any subsequent recalibration is based on the corrected characteristic.

# 12 CONFIGURATION LEVEL C2

## 12.6 Time-out

C2

Display

Logic functions

Cascade controller

Customized  
recalibration

**Time-out**

Start

Supply frequency

Real time clock

Interface

Value\* \_\_\_\_\_

Value range: 0 — 9999

factory-set: 30 (approx. 30 sec)

### Explanation:

☐ = input a value

☐ = factory setting

# 12 CONFIGURATION LEVEL C2

---

## 12.7 Unit

C2

Display

Logic controller

Cascade controller

Customize  
recalibration

Time to

Unit

Supply voltage

Resolution

interface

Degree Celsius
Degree Fahrenheit

### Explanation

Input value

Input setting

# 12 CONFIGURATION LEVEL C2

## 12.8 Supply frequency

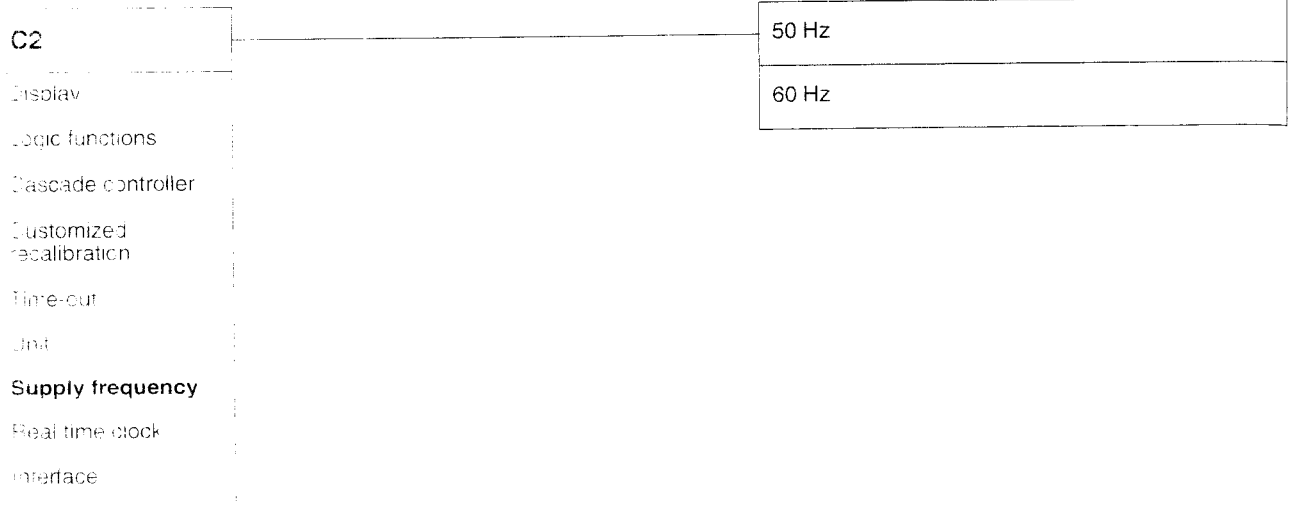

**Explanation:**

- Input a value
- Factory setting

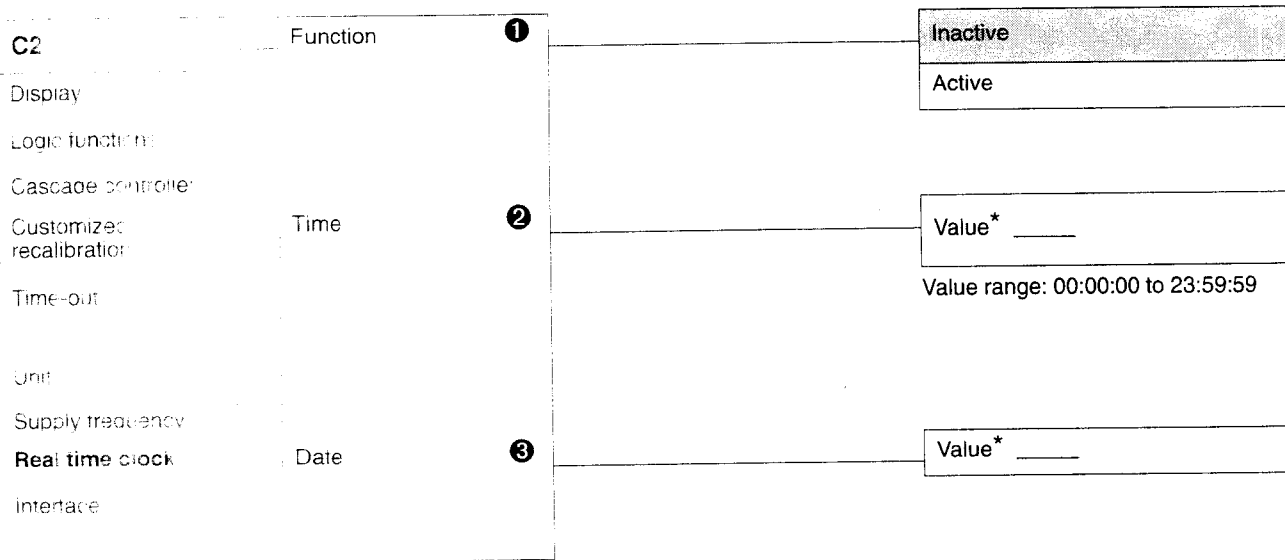

# 12 CONFIGURATION LEVEL C2

## 12.9 Real time clock



**Explanation:**

- \* = input value
- = factory setting

No.	Item	Display	Notes
①	Function	FUNCTION	 The function of the real time clock affects the indication of the parameters for profile program start (date/time or delay).
②	Time	TIME      00:00:00	Input the clock time in the format hh:mm:ss   The change to summer time must be made manually.
③	Date	DATE      24:12:96	Input the date in the format DD:MM:YY   Leap year is allowed for automatically.

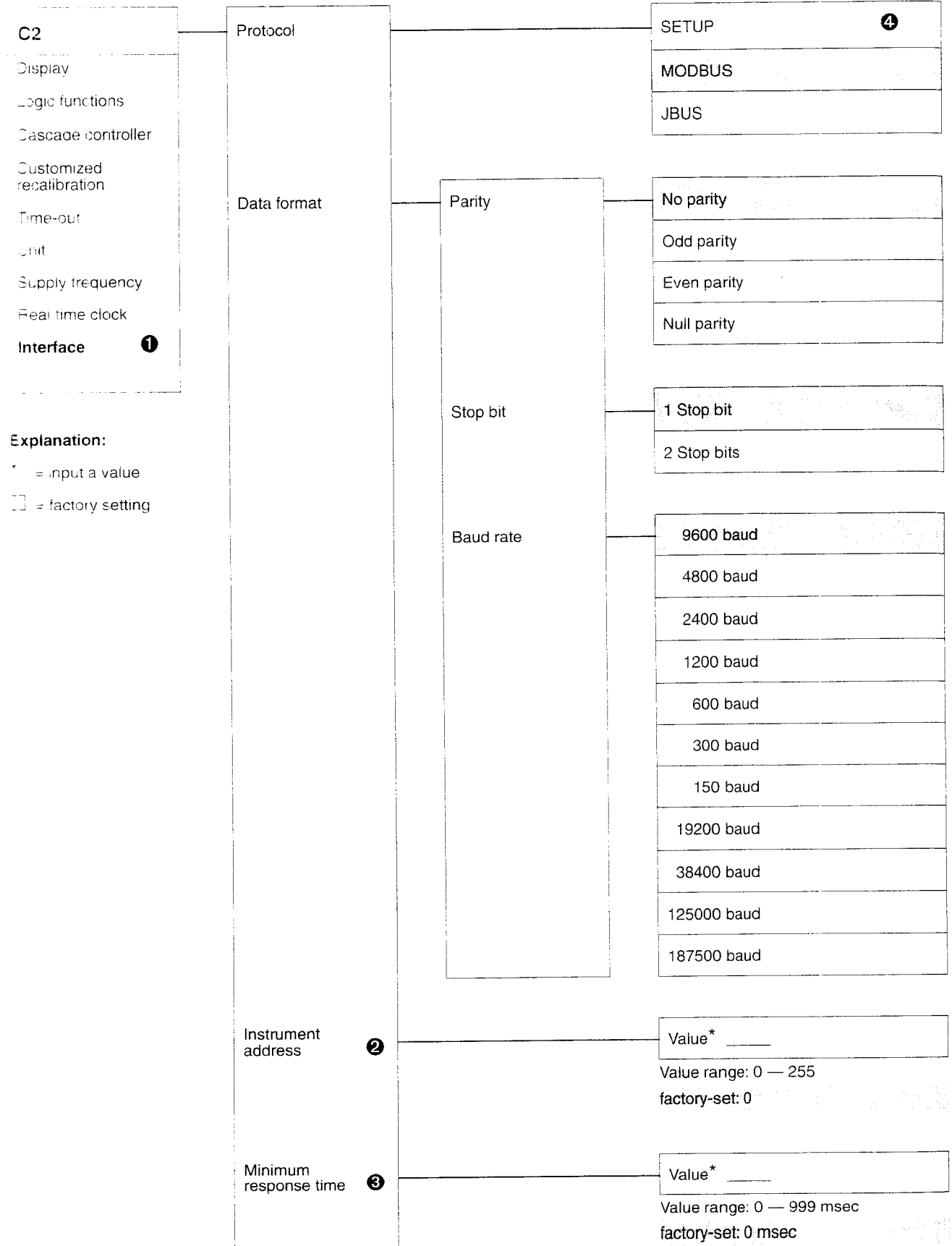

# 12 CONFIGURATION LEVEL C2

## Interface



## 12 CONFIGURATION LEVEL C2

---

No.	Item	Display	Notes
①	Interface	INTERFACE	 Section 16.2  B 70.3560.2 Interface description
②	Instrument address	INSTR.ADDR	—
③	Minimum response time	MIN.TIME	Minimum time interval from the interrogation of an instrument in a data network up to the controller response.
④	SETUP	SETUP	 The SETUP data format requires the setting “even parity”

# 13 CONFIGURATION LEVEL C3

---

## 13.1 Overview





Version	①
VDN Number	②
Inputs 3 + 4	③
Output 1	④
Output 2	④
Output 3	④
Output 4	④
Setup interface	⑤
Interface	⑥
External relay module	⑦
Data back-up	⑧
Number of controllers	⑨
Maths and logics module	⑩
Carbon level	⑪



No data can be input at this level.  
It alters automatically when hardware  
or software are changed or retrofitted.

# 13 CONFIGURATION LEVEL C3

## Overview

No.	Item	Display	Notes
①	Version	VERSION	Version number of software
②	VDN Number	VDN-NO	Number of special controller version
③	Inputs 3 + 4	ADC MODULE 2	<ul style="list-style-type: none"> <li>- Available</li> <li>- Not available</li> </ul>
④	Output 1	OUPUT 1	<ul style="list-style-type: none"> <li>- Not available</li> <li>- Relay</li> <li>- Solid-state relay</li> <li>- Analogue output</li> <li>- Logic output</li> </ul>
⑤	Setup interface	SETUP INTERFACE	<ul style="list-style-type: none"> <li>- Connected</li> <li>- Not connected</li> </ul> <p style="text-align: right;"> Section 16.4</p>
⑥	Interface	INTERFACE	<ul style="list-style-type: none"> <li>- Not available</li> <li>- RS 422 / RS 485 (see label)</li> </ul> <p style="text-align: right;"> Section 16.2</p>
⑦	External relay module	RELAY MODULE	<ul style="list-style-type: none"> <li>- Available</li> <li>- Not available</li> </ul> <p style="text-align: right;"> Section 16.1</p>
⑧	Data back-up	DATA BACK-UP	<ul style="list-style-type: none"> <li>- Loaded</li> <li>- Not loaded</li> </ul>
⑨	Number of controllers	CONTROLLERS	Single-channel controller 2-channel controller
⑩	Maths and logics module	MATHS-LOGICS	<ul style="list-style-type: none"> <li>- Available</li> <li>- Not available</li> </ul> <p style="text-align: right;"> Section 16.3</p>
⑪	Carbon level	C-LEVEL CONTR.	<ul style="list-style-type: none"> <li>- Available</li> <li>- Not available</li> </ul>

# 14 BINARY FUNCTIONS

The binary functions are activated through floating contacts (switches/relay contacts), limit comparators, operating contacts or logic outputs (logics module).

The functions are divided into two groups:

### Edge-triggered functions

The binary function responds to the leading (switch-on) edge.

The following functions are edge triggered:

- start self-optimisation
- abort self-optimisation
- start profile program
- stop profile program
- abort profile program

### Status-operated functions

The binary functions respond to switch-on or switch-off states.

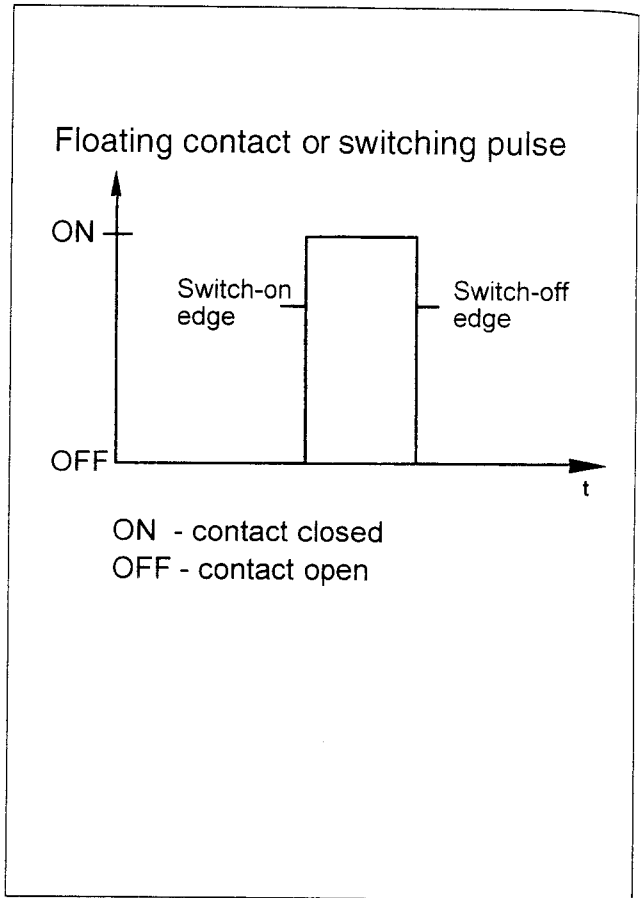

## 14.1 Combined binary functions

The functions setpoint changeover, process value changeover and parameter set switching are realised by the combination of two operating variables (logic inputs, limit comparators, logic outputs (logics module) and operating contacts).

The profile program selection function is realised through four operating variables.

The selection of operating variables is unrestricted. The assignment of the states Z1 – Z2(Z4) to the operating variables is made in descending order (see list).

Example:

The changeover of the process value is to operate through a logic input and the status of an operating contact.

Z1 – Logic input 1

Z2 – Operating contact 1

Assignment:	status - operating variable
Z1	Logic input 1 • •
Z2	Logic input 5 Limit comparator 1 • •
Z3	Limit comparator 8 Logic 1 Logic 2
Z4	Operating contact 1 • • • Operating contact 8

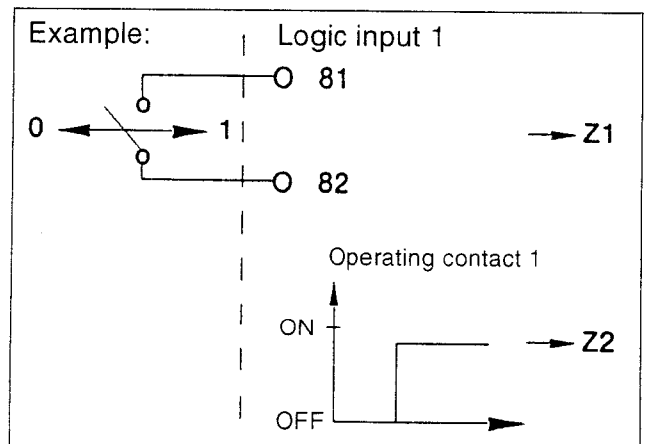

# 14 BINARY FUNCTIONS

## Truth tables

Setpoint	Process value	Parameter set	Z2	Z1
Setpoint of profile programmer	Analogue input 1	Parameter set 1	0	0
Setpoint 2	Analogue input 2	Parameter set 2	0	1
Setpoint 3	Analogue input 3	Parameter set 3	1	0
Setpoint 4	Analogue input 4	Parameter set 4	1	1

0 = contact open /OFF

1 = contact closed /ON



To switch between two setpoints (analogue inputs, parameter sets) only one binary function has to be configured and linked to switches.



If more than two binary functions are configured for setpoint changeover (process value changeover, parameter set switching), only the first two are significant (see list).

Program selection: the first 16 profile programs can be selected through four functions.

Program	Z4	Z3	Z2	Z1
Profile program 0	0	0	0	0
Profile program 1	0	0	0	1
Profile program 2	0	0	1	0
Profile program 3	0	0	1	1
Profile program 4	0	1	0	0
Profile program 5	0	1	0	1
Profile program 6	0	1	1	0
Profile program 7	0	1	1	1
Profile program 8	1	0	0	0
Profile program 9	1	0	0	1
Profile program 10	1	0	1	0
Profile program 11	1	0	1	1
Profile program 12	1	1	0	0
Profile program 13	1	1	0	1
Profile program 14	1	1	1	0
Profile program 15	1	1	1	1

# 14 BINARY FUNCTIONS

## 14.2 Other functions

Function	Contact closed /ON	Contact open /OFF
Start self-optimisation	Self-optimisation is started	—
Abort self-optimisation	Self-optimisation is aborted	—
Key inhibit	Keys are inhibited	Keys are <b>not</b> inhibited
Parameter and configuration levels inhibit	Levels are inhibited	Levels are <b>not</b> inhibited
Text display	Text is shown on the matrix display. Action according to priority list  Section 19.3	Displays according to status and configuration
All displays off	Displays are off Action according to priority list  Section 19.3	Displays according to status and configuration
Auto/manual changeover	Changeover to auto-manual or manual operating mode	—
Profile program editor inhibit	Profile program editor is inhibited	Profile program editor is <b>not</b> inhibited
Profile start	The selected profile program (profile start) is started immediately. The start day/start time and delay settings are ineffective.	—
Profile stop	Changeover to auto-manual operating mode	Changeover to auto-manual operating mode
Fast forward	Profile program continues at the start of the next segment (profile 1). Profile 2 and the operating contacts are carried along in synchronism.	—

# 15 OPTIMISATION

Control engineering distinguishes between two different optimisation criteria: "control" and "disturbance".

For good **control response** it is desirable to achieve rapid approach of the process value to the setpoint without overshoot.

Good **disturbance response** involves extensive suppression of process value fluctuations caused through external influences on the control loop.

Where a control loop can be accurately represented in mathematical terms it is possible to calculate the appropriate controller parameters. Such a mathematical description is only rarely found in practice.

Certain procedures for control loop analysis and for determining controller parameters, as described below, are therefore employed.

The controllability of the process can be expressed through the ratio  $T_g/T_u$ .

The diagram alongside shows schematically the behaviour of a control loop with saturation in response to a step change.

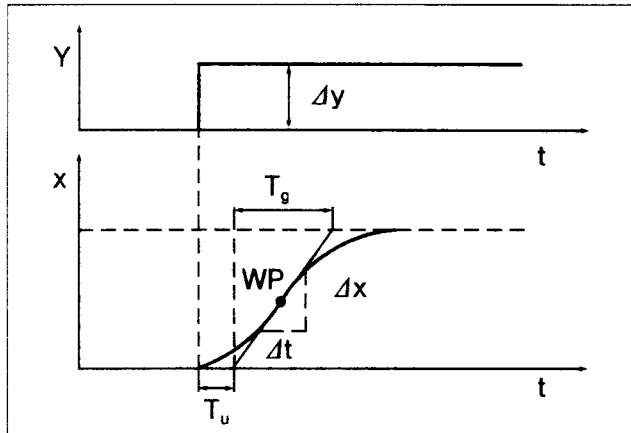

$T_g/T_u$  more than 10: satisfactory control

$T_g/T_u$  from 10 to 3: just controllable

$T_g/T_u$  less than 3 : difficult to control

The following facilities for optimisation are available:

## Classical optimisation methods

⇒ Section 15.1

## Self-optimisation

⇒ Section 15.2

## Improving the control and disturbance response through fuzzy parameters

⇒ Section 15.3

## List of symbols

Cy	switching cycle time
k	constant for output steps less than 100%
t	time
$T_g$	stabilisation time
$T_k$	oscillation period in case of oscillation
$T_n$	reset time
$T_u$	delay time
$T_v$	derivative time
$v_{max}$	max. rate of rise
w	setpoint
WP	inflection point
x	process value
$X_p$	proportional band
$X_{pk}$	setting of $X_p$ in case of oscillation
$X_{Sd}$	switching differential
$X_{Sh}$	contact spacing
Y	control output in %
Y1	upper output limit in %
Y2	lower output limit in %
$\Delta y$	output step in %
$\Delta t$	time difference
$\Delta x$	process value difference

# 15 OPTIMISATION

## 15.1 Optimisation method after Ziegler and Nichols

Many control loops (pressure, flow, level, humidity) can be represented mathematically by a combination of a dead time and a first-order time constant. Ziegler and Nichols have determined empirical setting criteria for the controller parameters on such control loops. These settings are particularly suitable for good disturbance response.

### Oscillation method

This method applies to control loops which can be rendered unstable for a brief period.

(a) For proportional controllers

The controller is first operated with the following settings:

- \* set controller to P action
- \* set  $X_{p1}$  (and  $X_{p2}$ ) to maximum
- \* set contact spacing  $X_{Sh}$  to 0
- \* slowly reduce  $X_{p1}$  (and  $X_{p2}$ ) to find the stability limit at which the process value performs oscillations of constant amplitude

$X_{pk}$  = setting of  $X_p$

$T_k$  = oscillation period

The controller parameters for the different controller structures can be calculated according to the table alongside.

(b) For switching controllers

It is possible to achieve roughly similar satisfactory results through the following procedure:

- \* Set  $X_{p1}$  (and  $X_{p2}$ ), the switching differential  $X_{Sd}$  and the contact spacing to 0.

Compared with proportional controllers there is roughly twice the oscillation amplitude. By dividing the value of the oscillation amplitude by two it is possible to use the above formulae to calculate the parameters for a PID structure.

$$X_{pk} = \frac{\text{oscillation amplitude}}{2}$$

The switching cycle time  $Cy$  should then be set according to the following equation:

$$Cy = T_k/12 \text{ approx.}$$

If after stabilisation there remain permanent process value oscillations in synchronism with the switching action it is recommended to reduce  $Cy$  further.

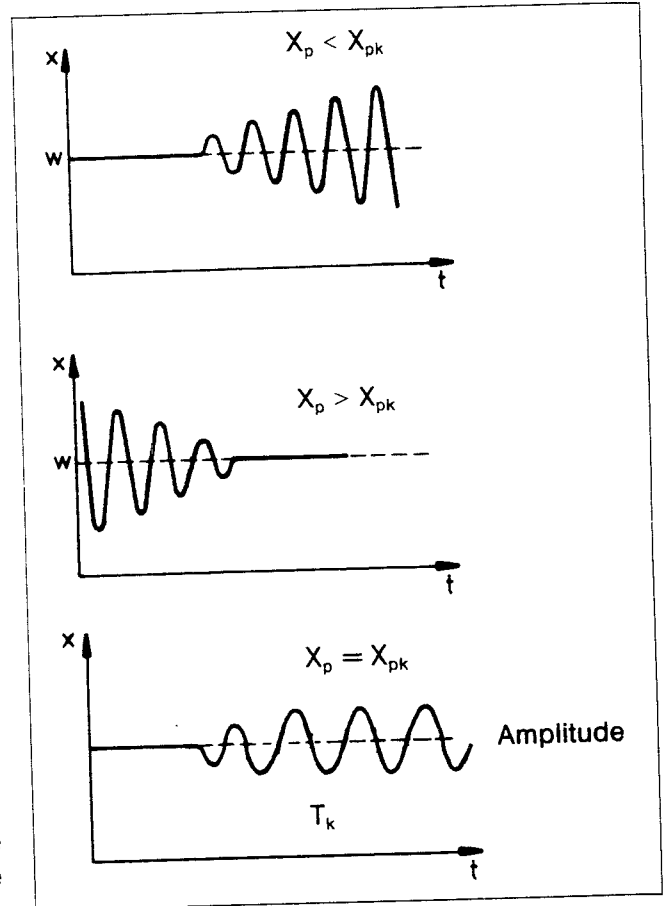

Controller structure	Setting
P	$X_p = \frac{X_{pk}}{0.5}$
PI	$X_p = \frac{X_{pk}}{0.45}$ $T_n = 0.85 \cdot T_k$
PID	$X_p = \frac{X_{pk}}{0.6}$ $T_n = 0.5 \cdot T_k$ $T_v = 0.12 \cdot T_k$

# 15 OPTIMISATION

## Recording the control loop step response

In this method the response of the control loop to a step change in control output is recorded. It is advisable to carry out this test in the neighbourhood of the intended working range; it can not be assumed that the control loop exhibits a similar behaviour in other regions.

- \* Record the process value using a pen recorder
- \* Produce an output step  $\Delta y$  (manual operation)
- \* Leave the recorder switched on at least long enough until the point of inflection is passed and the rate of rise of the process value decreases again.
- \* Draw the tangent through the point of inflection WP
- \* Calculate  $v_{max} = \Delta x / \Delta t$
- \* Read off  $T_u$
- \* Calculate the constant k:

$$k = \frac{(Y_1 - Y_0)}{\Delta y \cdot 100 \%}$$

(k is a correction factor for output steps within the output limits  $Y_1$  and  $Y_2$ )

- \* Insert the value obtained from the diagram into the formulae and calculate the controller parameters.

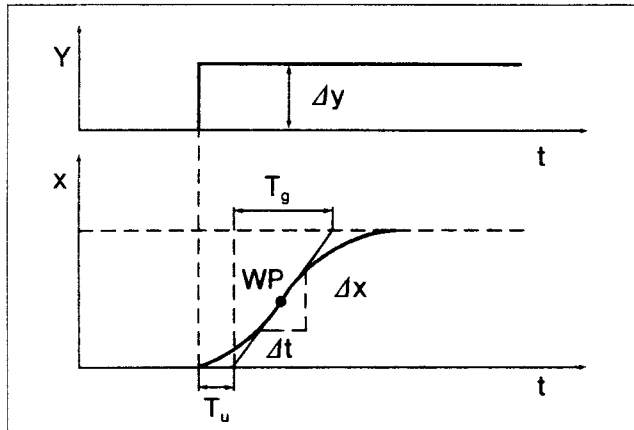

Controller structure	Setting
P	$X_p \approx v_{max} \cdot T_u \cdot k$
PI	$X_p \approx 1.2 \cdot v_{max} \cdot T_u \cdot k$ $T_n \approx 3.3 \cdot T_u$
PID	$X_p \approx 0.83 \cdot v_{max} \cdot T_u \cdot k$ $T_n \approx 2 \cdot T_u$ $T_v \approx 0.5 \cdot T_u$



During the optimisation procedure and in particular during alterations of the controller parameters it is possible to reach conditions which must not be allowed to appear during normal operation.

It is advisable to monitor the process continuously during optimisation in order to avoid consequential damage.

# 15 OPTIMISATION

## 15.2 Self-optimisation

The self-optimisation function (SO) is purely a software function and is incorporated in the controller.

SO employs a special procedure to analyse the response of the control loop to steps in control output. Using the control loop response (process value) an extensive computing algorithm determines the controller parameters for a PID controller and stores them. If a double-setpoint controller has to be optimised the algorithm determines two separate proportional bands ( $X_{p1}$  and  $X_{p2}$ ). In case of a switching double-setpoint controller the switching cycle time  $Cy2$  is also calculated. The SO procedure can be repeated as often as desired.



SO can be activated by keys, logic inputs or menu settings. In case of cascade control, the controller of the inner control loop must be optimised first.

SO operates according to two different procedures which are selected automatically depending on the dynamic state of the process value and its distance from the setpoint at the start of SO. SO can be performed starting from any dynamic course of the process value.

If process value and setpoint are far apart when SO is activated, a switching line is determined and the controlled value is made to perform a forced oscillation about this line during the self-optimisation procedure.

The switching line is selected so that the process value preferably does not go beyond the setpoint. If there is only a small control deviation between setpoint and process value, e.g. when the control loop has stabilised, an enforced oscillation is produced about the setpoint.

Using the recorded process loop data the calculation determines the controller parameters  $T_n$ ,  $T_v$ ,  $X_{p1}$ ,  $X_{p2}$ ,  $Cy1$ ,  $Cy2$  and also the optimum filter time constant for this control loop for filtering the process value. The fuzzy parameters  $Fc1$  and  $Fc2$  are set to their base values. SO is then successfully concluded.



If after stabilisation a switching controller exhibits permanent process value oscillations in synchronism with the switching action it is recommended to reduce  $Cy$  further.

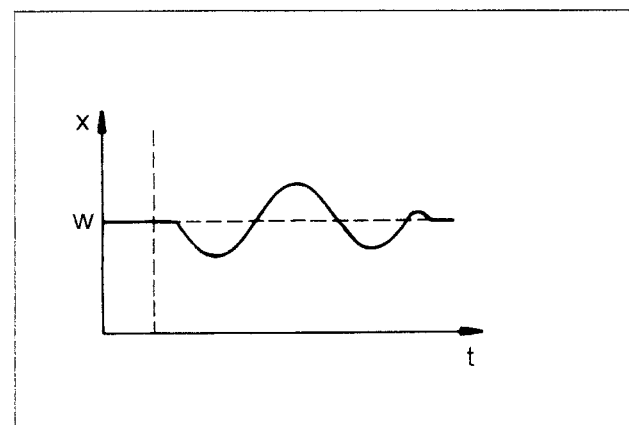
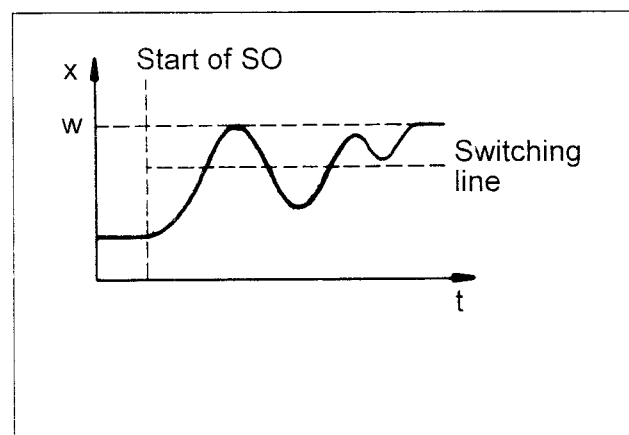
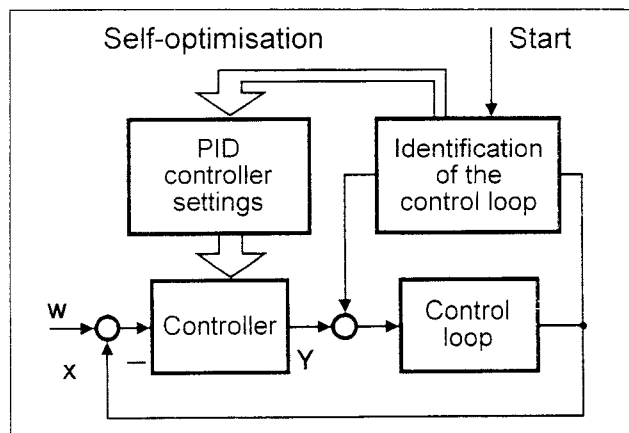

# 15 OPTIMISATION

## 15.3 Fuzzy parameters

In addition to the algorithms for the various controller structures the controller software also includes a fuzzy module. This can be used to improve both the control and the disturbance response of the controller.

When supplied, and also after self-optimisation, the fuzzy parameters are set to  $Fc1 = 0$  and  $Fc2 = 30$

The fuzzy module can be activated at any time by setting  $Fc1 > 0$

The setting  $Fc2 = 30$  is suitable for many applications. The optimum setting can be determined with the aid of the table at the bottom right.

When the fuzzy module is activated the control output  $y$  is made up of the controller output and the output signal of the fuzzy module. The parameter  $Fc1$  determines the intensity of the fuzzy signal!

- $Fc1 = 0$  fuzzy module not activated
- $0 < Fc1 < 100$  fuzzy module is activated

If the fuzzy module activated by  $Fc1$  makes corrections to the control output  $y$  the reset time  $T_n$  is influenced during the correction.

The parameter  $Fc2$  is used to adjust the degree of influencing the reset time  $T_n$ .

- $Fc2 = 0$  no influence on  $T_n$
- $0 < Fc2 < 100$  influence on  $T_n$



if the fuzzy module is inactivated ( $Fc1 = 0$ ) there is no influence through  $Fc2$ .

The action and sensitivity of the fuzzy parameters depend very largely on the process being controlled.

The influence is greater in the case of proportional controllers than with switching controllers.

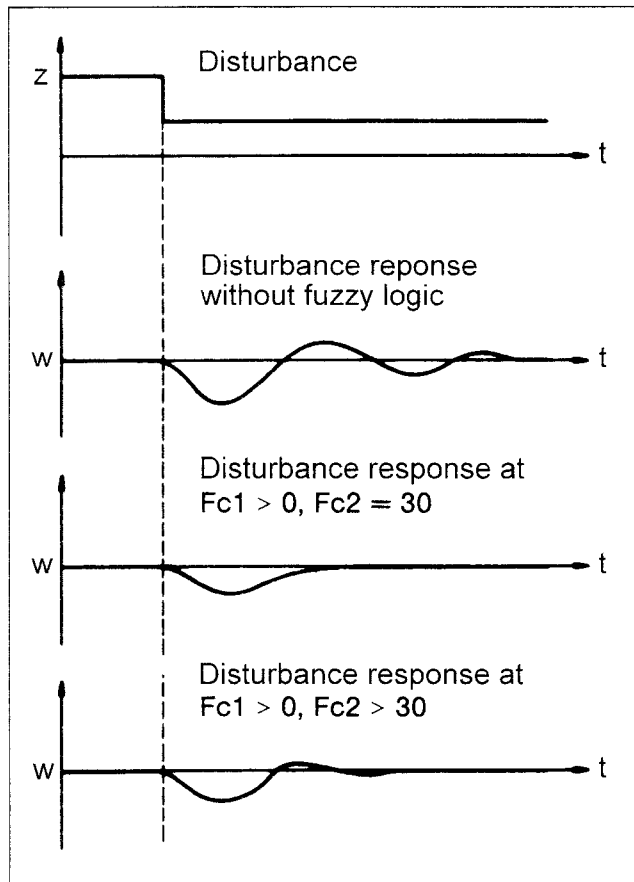
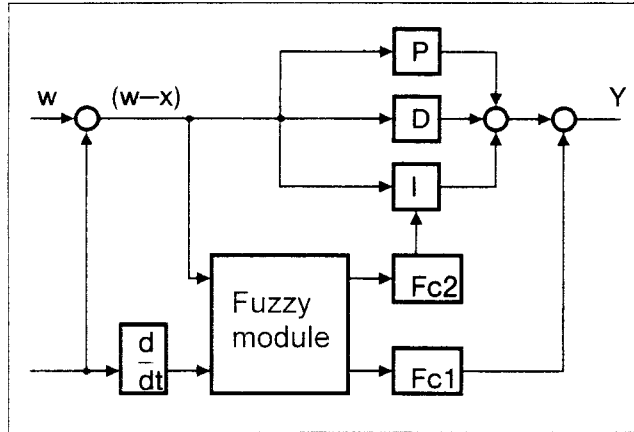

Action	Response
$Fc1 \uparrow$	disturbance amplitude reduced, stabilisation time increased
$Fc1 \downarrow$	disturbance amplitude increased, stabilisation time reduced
$Fc2 \uparrow$	stabilisation time reduced
$Fc2 \downarrow$	stabilisation time increased

# 15 OPTIMISATION

## 15.4 Checking the optimisation

The optimum adjustment of the controller to the process can be checked by recording a start-up with the control loop closed.

The diagrams below indicate possible incorrect adjustments and the corrections required. The control response of a third-order control loop for a PID controller is shown as example. The procedure for adjusting the controller parameters can, however, also be applied to other control loops.

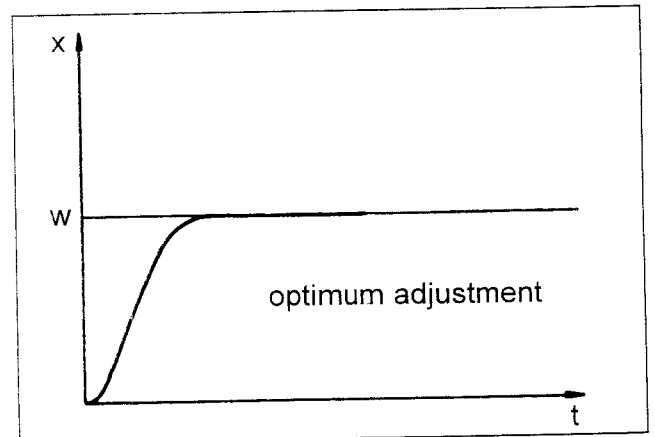
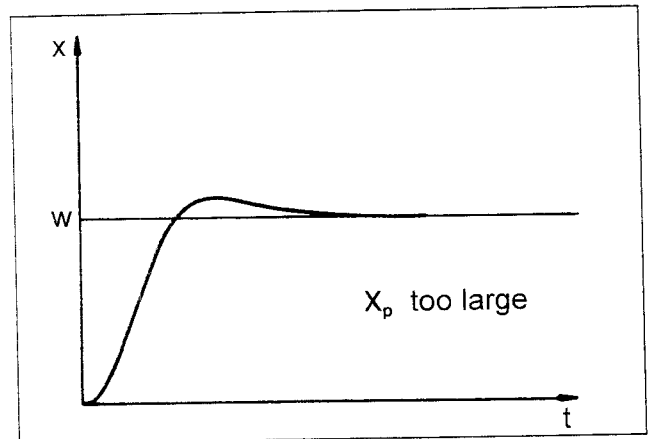
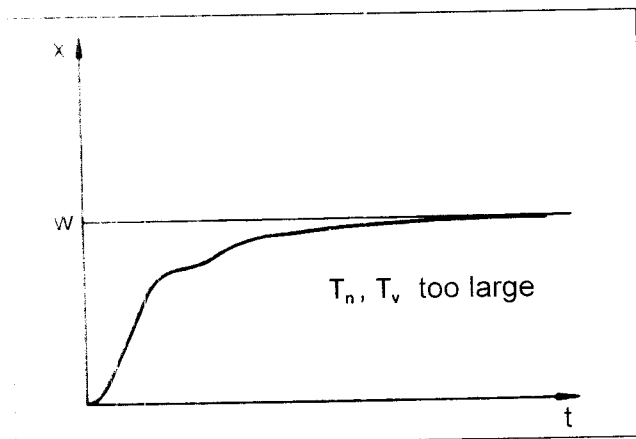
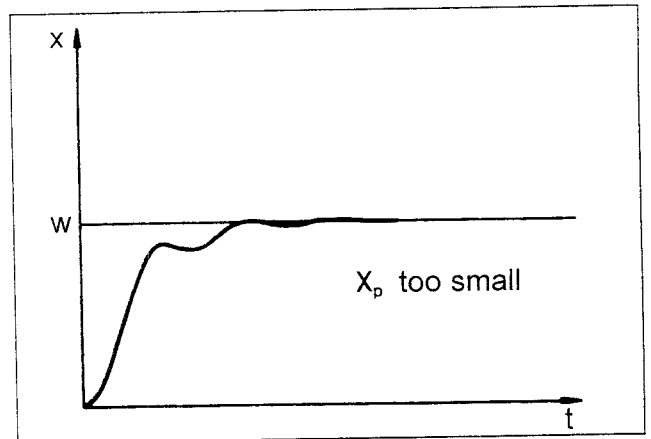
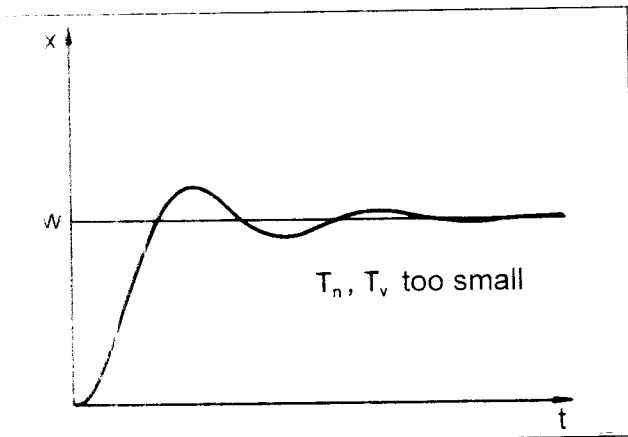

# 16 EXTRA CODES AND ACCESSORIES

## 16.1 External relay module ER8

Through the use of the external relay module ER8 a further eight switched outputs can be added to the controller.

The connection between controller and relay module is made through a serial interface.

The following functions can be assigned to the outputs:

The external relay outputs 1 — 8 correspond to the contacts K5 — K12.

- controller outputs
- limit comparators
- logic linkages

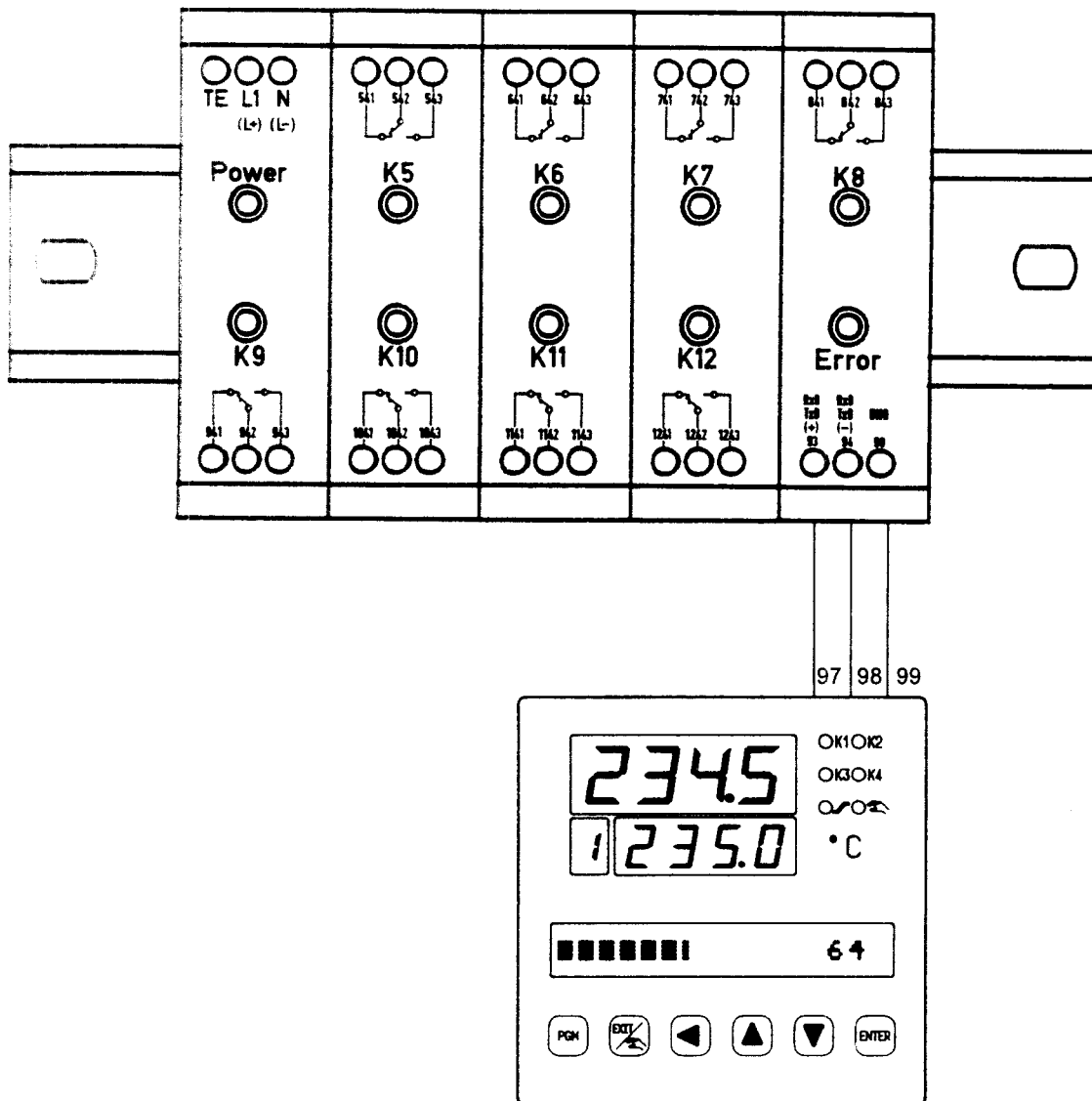

# 16 EXTRA CODES AND ACCESSORIES

## 16.2 RS422/RS485 interface

Using the interface the controller can be integrated into a data network. The following applications can be realised, for example:

- visualising the process
- system control
- generating reports

The bus system is designed on the master-slave principle. A master computer can address up to 31 controllers and instruments (slaves). The interface is a serial interface to the RS422 or RS485 standard.

The following data protocols are available:

- MODbus protocol
- Jbus protocol
- SETUP protocol



Interface description B 70.3560.2

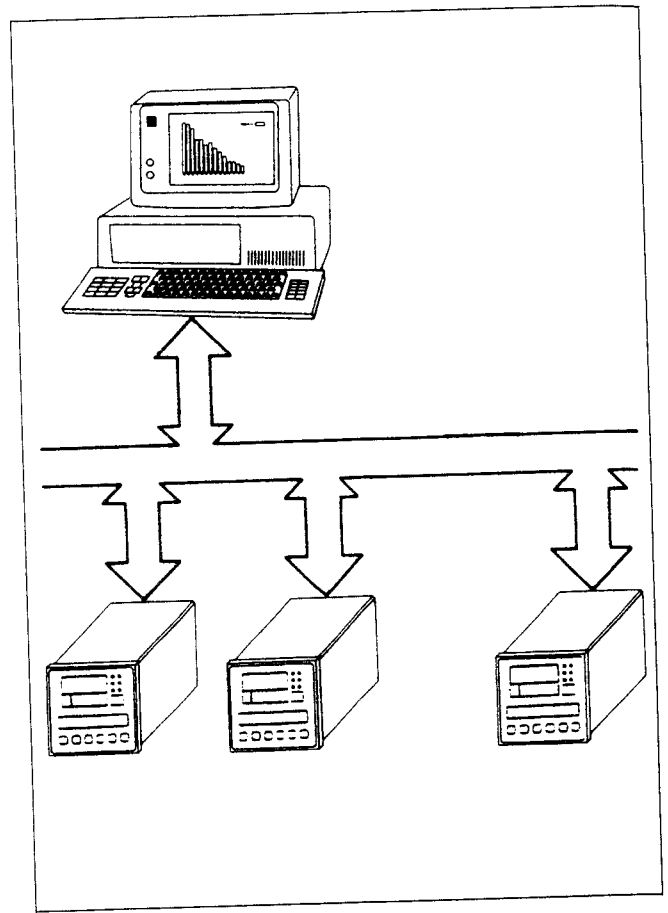

# 16 EXTRA CODES AND ACCESSORIES

## 16.3 Maths and logics module

The maths module processes real and Boolean values. The starting point is a real value.

The logics module processes Boolean values. The starting points are Boolean values.

The sampling time of the controller may be extended depending on the extent of the calculations.

The settings "difference", "ratio" and "humidity" represent the standard formulae for the corresponding controller types.

The parameters "variable a" and "variable b" provide the appropriate input values for these formulae.



Sections 17.4, 17.5, 17.6

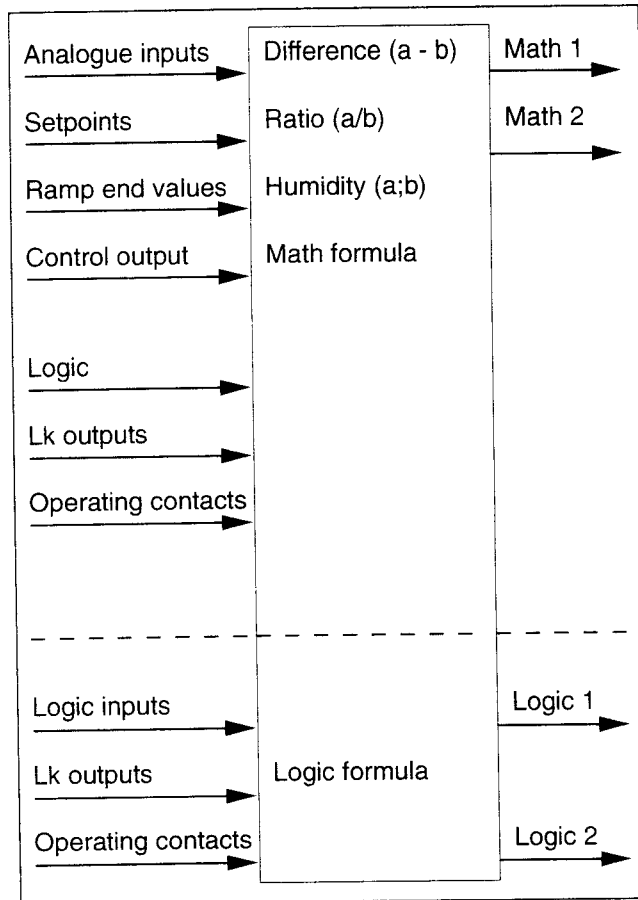

### 16.3.1 Math formula

The maths module permits linking various analogue and Boolean inputs through a mathematical formula.

A formula can be specified for each of the two output values (Math 1/2).

Formula input:

- The formula chain consists of ASCII characters and has a maximum length of 70 characters.
- The formula can be input only in the setup program.
- The formulae can be input freely according to the usual mathematical rules.
- Space characters can be inserted in the formula chain without restriction. There must be no space character within function designations, names of variables, and constants.

If the formula chain contains an error, an error message is output after entering the input, and the cursor is positioned on the error.

Example:

#### Math formula

Formula 1:

```
(AIN1+AIN2+AIN3)/3
```

Formula 2:

```
30*SQRT(AIN1)
```

# 16 EXTRA CODES AND ACCESSORIES

## Mathematical signs and functions

Priority	Mathematical sign/function	Note
high	()	Brackets
	SQRT, MIN, MAX, LOG, LN, SIN, COS, TAN, ABS, EXP	Functions
	**	Exponent ( $x^y$ )
	+, -	Sign
	*, /	Multiplication, division
low	+, -	Addition, subtraction

## Variables

Variable name	Note
AIN1 or E1	analogue input 1
AIN2 or E2	analogue input 2
AIN3 or E3	analogue input 3
AIN4 or E4	analogue input 4
WR1	Setpoint controller 1
WR2	Setpoint controller 2
WE1	Ramp end point controller 1
WE2	Ramp end point controller 2
Y1	Control output controller 1
Y2	Control output controller 2
W12	Setpoint 2 controller 1 (operating level)
W13	Setpoint 3 controller 1 (operating level)
W14	Setpoint 4 controller 1 (operating level)
W22	Setpoint 2 controller 2 (operating level)
W23	Setpoint 3 controller 2 (operating level)
W24	Setpoint 4 controller 2 (operating level)
LK1	Output limit comparator 1
...	:
LK8	Output limit comparator 8
SK1	Operating contact 1
...	:
SK8	Operating contact 8
L1	Logic 1
L2	Logic 2

## 16 EXTRA CODES AND ACCESSORIES

Syntax	Function
SQRT a	<p>Square root of a</p> <p>Examples:   SQRT(AIN2)               SQRT(13.5 + AIN3)</p>
MIN(a1, a2, ...)	<p>Returns the smallest value of a series of arguments</p> <p>Examples:   MIN(3.4, 7) (returns the value 3.4)               MIN(AIN1, AIN2, AIN3, 0.1)</p>
MAX(a1, a2, ...)	<p>Returns the largest value of a series of arguments</p> <p>Examples:   MAX(3.4, 7) (returns the value 7)               MAX(AIN1, AIN3, AIN3, 0.1+AIN4)</p>
LOGa	<p>Logarithm to base 10</p> <p>Examples:   LOG(1000) (returns the value 3)               LOG(AIN1/100)</p>
LNa	<p>Logarithm to base e</p> <p>Examples:   LN(2.71828128) (returns the value 1)               LN(AIN1/100)</p>
SINa	<p>Sine of a a in degrees (0 — 360°)</p> <p>Examples:   SIN(90) (returns the value 1)               SIN(AIN1*360/100)</p>
COSa	<p>Cosine of a a in degrees (0 — 360°)</p> <p>Examples:   COS(180) (returns the value -1)               COS(AIN1*360/100)</p>
TANa	<p>Tangent of a a in degrees (0 — 360°)</p> <p>Examples:   TAN(45) (returns the value 1)               TAN(AIN1*45/100)</p>
ABSa	<p>Absolute value of a</p> <p>Examples:   ABS(-12) (returns the value 12)               ABS(13.5+AIN3)</p>
EXPa	<p>Exponential function <math>e^a</math></p> <p>Examples:   EXP(1) (returns the value 2.718)               EXP(AIN1/100)</p>

# 16 EXTRA CODES AND ACCESSORIES

## 16.3.2 Logic formula

The logics module provides a facility for logically linking the logic inputs, the LK outputs and the operating contacts. A formula can be specified for each of the two Boolean output values (Logic 1/2).

Example:

### Logic formula

Formula 1:

**(BIN1 OR BIN2) AND LK1**

Formula 2:

**LK1 OR LK2 OR LK3**

## Logic operators

Priority	Operator	Note
high	( )	Brackets
	NOT	Negation
	AND, &	AND linkage
	XOR, ^	Exclusive OR linkage
low	OR,	OR linkage

## Variables

Variable name	Note
BIN1 or B1	Logic input 1
...	...
BIN5 or B5	Logic input 5
LK1	Output limit comparator 1
...	...
LK8	Output limit comparator 8
SK1	Operating contact 1
...	...
SK8	Operating contact 8

## Constants

Constant name	Note
TRUE	logic 1
FALSE	logic 0

# 16 EXTRA CODES AND ACCESSORIES

## 16.4 Setup program

A setup program is available to permit easy configuration of the controller.

The program runs under the JUMODESK user interface which is based on the widely-used SAA standard. This ensures simple operation.

The program can be operated from the keyboard or with the mouse

Hardware requirements:

IBM-AT or compatible computer to the following specification:

- 640 kB RAM (at least 480 kB free)
- 3 1/2" disk drive
- hard disk (at least 3 MB free)
- serial interface (RS232)

Software requirements:

- MS-DOS Version 3.3 or higher
- mouse support from driver version:
  - Microsoft Version 6.24
  - Logitech Version 4.10
  - Genius Version 9.02

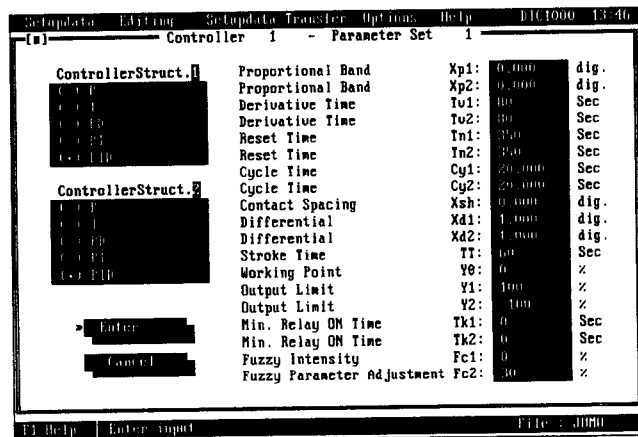
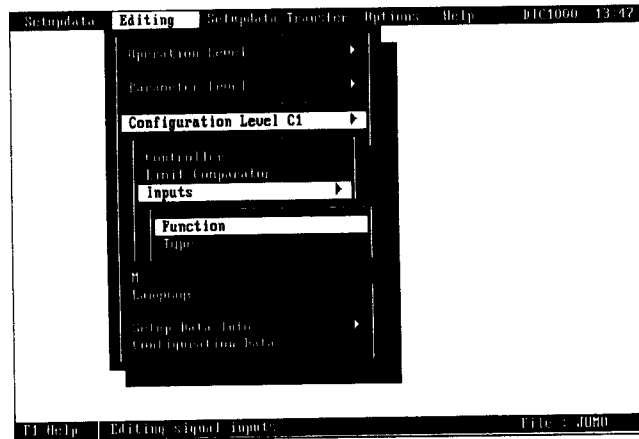
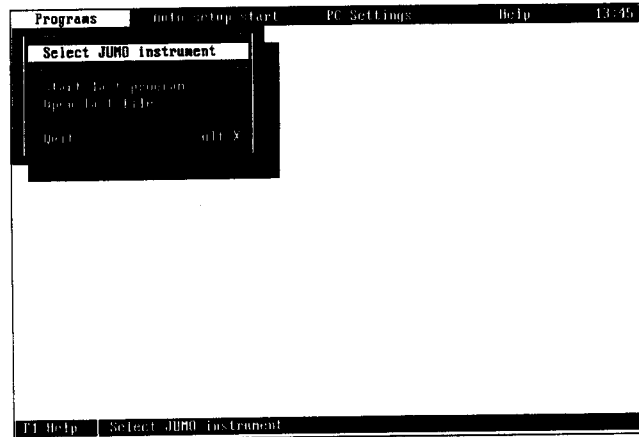

Installation:

- \* Place diskette into the drive
- \* Input:  
A:INSTALL or B:INSTALL
- \* After installation has been completed start the user interface with JUMODESK



If a setup program has already been installed on the computer, additional copying is limited to the missing data.



Be certain to make a back-up copy of your setup program.

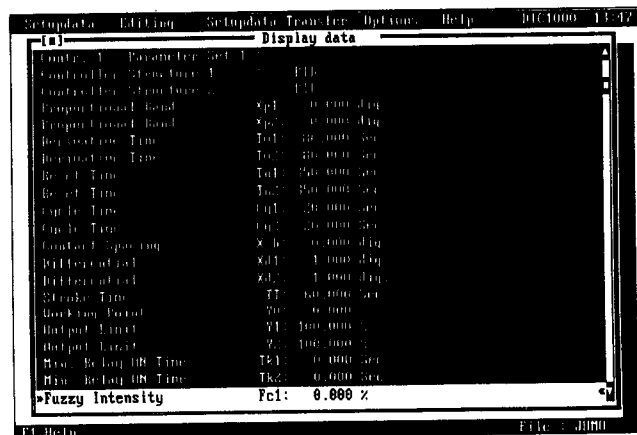

# 16 EXTRA CODES AND ACCESSORIES

## 16.5 C-level control

C-level control is used to regulate the carbon activity in the atmosphere of a gas carburisation furnace. The C-level is determined by measuring the oxygen level, with a zirconium dioxide sensor, and the sensor temperature.



Section 17.13

### 16.5.1 C-level calculation

The calculations are made by the controller according to the following formula:

$$E = 0.0992 \cdot T \cdot [-\log(P_{CO}) + K_0 + 0.15 \cdot C_p + \log(C_p)] \cdot \text{mV}/^\circ\text{C} + 816.1 \text{ mV}$$

- E = e.m.f. of the zirconium dioxide sensor
- T = sensor temperature in °K
- P<sub>CO</sub> = partial pressure of CO in % by volume
- K<sub>0</sub> = furnace correction
- C<sub>c</sub> = carbon level

### 16.5.2 Control sequence

The operation of a zirconium dioxide sensor has to follow a fixed time frame. The sensor must be flushed at regular intervals (cycle time) in order to ensure error-free measurement.

The controller is on manual operation during flushing and the following recovery time. The last measured value is stored. The output is the average of the latest controller outputs.

During flushing the logic 1 output is at "1". Linking with an output provides control of the flushing procedure.

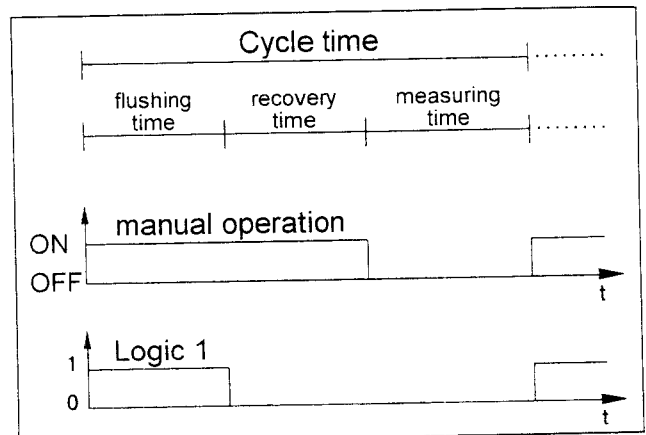

### 16.5.3 C-level menu

The C-level menu, on controllers with the Extra Code "C-level control", can be found between the operating and parameter levels.

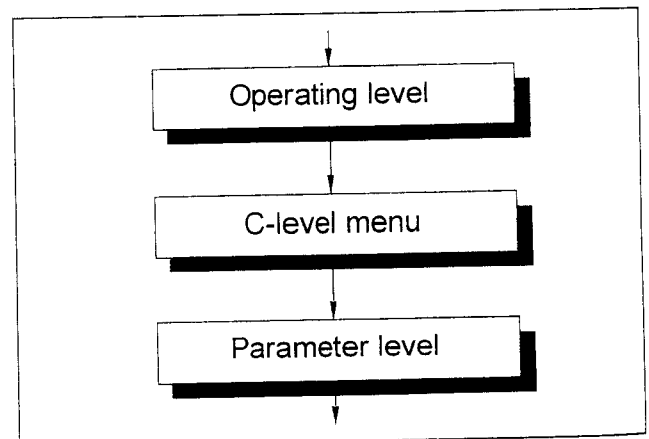

# 16 EXTRA CODES AND ACCESSORIES

## C-level measurement

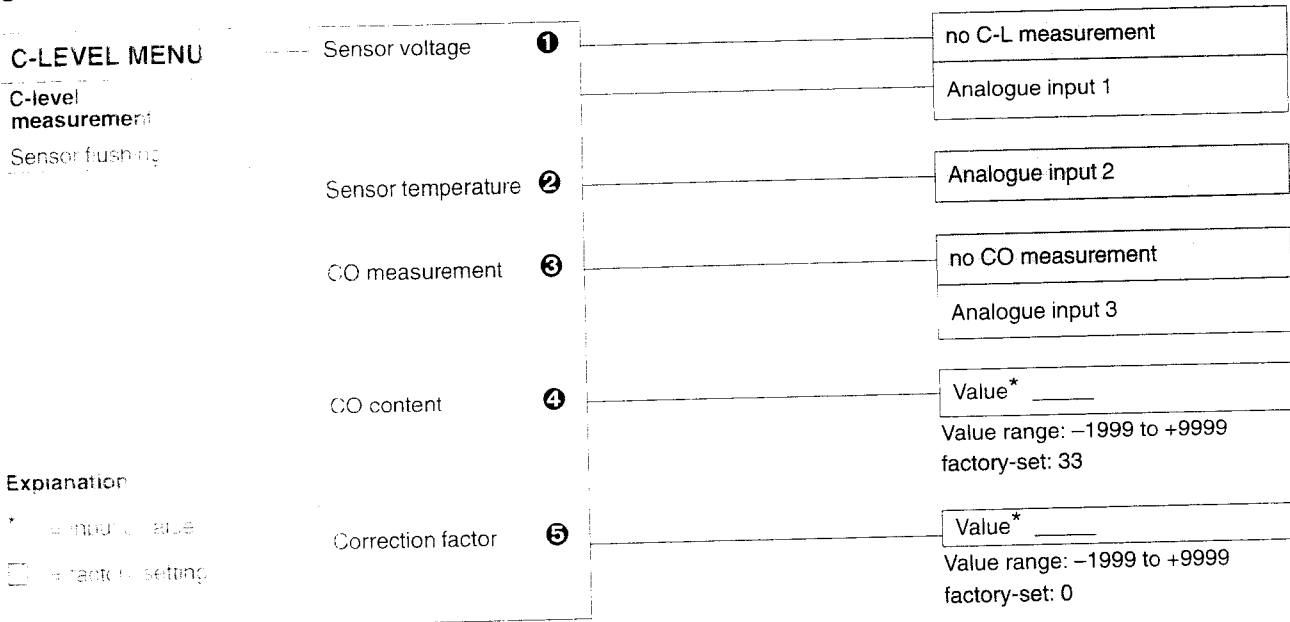

No.	Item	Display	Notes
①	Sensor voltage	SENSOR VOLTAGE	This activates the Extra Code "C-level control". If "no C-L measurement" is set, then the controller operates in the normal manner. The sensor voltage is measured at analogue input 1.  ➡ Section 16.5.4
②	Sensor temperature	SENSOR TEMP.	The sensor temperature is always measured at analogue input 2.
③	CO measurement	CO MEAS.	The CO content is always measured at analogue input 3.
④	CO content	CO CONTENT	If "no CO measurement" is set at ③, then the known value for the CO content must be entered here in % by volume.
⑤	Correction factor	COR. VALUE	The correction factor is a C-level determined by reference measurement. The entry of a correction factor permits the calculation of the furnace correction as follows: $K_{0,new} = K_{0,old} + \log (C_{p,old} / C_{p,new} + 0.15 \cdot (C_{p,old} - C_{p,new}))$ $K_{0,new} = \text{new furnace correction}$ $K_{0,old} = \text{old furnace correction}$ $C_{p,old} = \text{previously calculated C-level}$ $C_{p,new} = \text{correction factor}$ If 0 is entered, the furnace correction is reset to the default value of 1.995

# 16 EXTRA CODES AND ACCESSORIES

## Sensor flushing

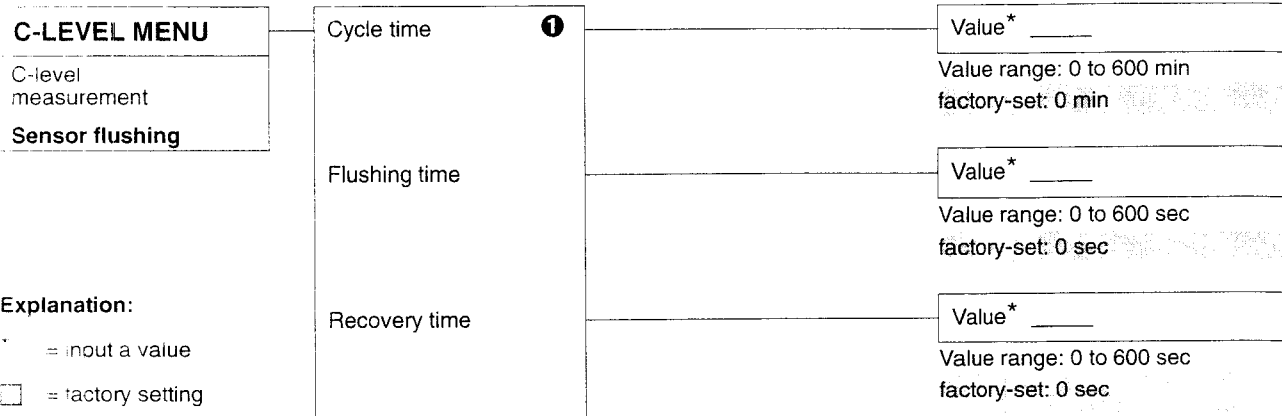

No.	Item	Display	Notes
①	Cycle time	P. TIME	—

# 16 EXTRA CODES AND ACCESSORIES

---

## 16.5.4 Notes



### Design changes

in units with the Extra Code "C-level control" the measurement ranges for analogue input 1 are changed as follows

0 — 10 V → 0 — 2 V

2 — 10 V → 0.4 — 2 V

There is no probe break monitoring.



### Maths module

The menu settings "Special function – Math 1" and "Special function – Logic 1" are ineffective when the C-level control is switched on.



### Oxygen measurement

The oxygen content can be calculated according to Nernst's equation, using the maths module.

$$P_{O_2} = P_{O_2,ref} \cdot \exp \left[ - (46.51 \cdot E) / (T_s + 273.2 \text{ °K}) \cdot \text{°K/mV} \right]$$

- $P_{O_2}$  = partial pressure of oxygen
- $P_{O_2,ref}$  = reference pressure (20.9%)
- $E$  = e.m.f. of the zirconium dioxide sensor
- $T_s$  = sensor temperature in °C

### Formula syntax (maths module)

$$0.209 \cdot \text{EXP} \left[ - (46.51 \cdot \text{AIN1}) / (\text{AIN2} + 273.2) \right]$$

# 17 CONFIGURATION EXAMPLES

## 17.1 Controller with parameter set switching depending on setpoint

The controller has to operate at two different setpoints (setpoint ranges) with different controller parameters.

By linking the setpoint to a limit comparator (lk7) it is possible to switch between two parameter sets.

Example:

- $w < 200\text{ °C} \rightarrow$  parameter set 1
- $w > 200\text{ °C} \rightarrow$  parameter set 2

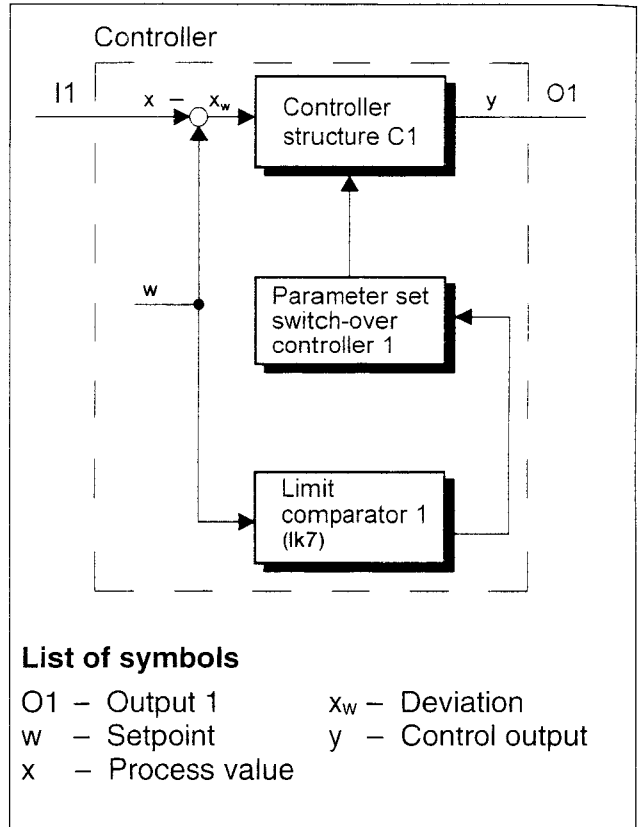
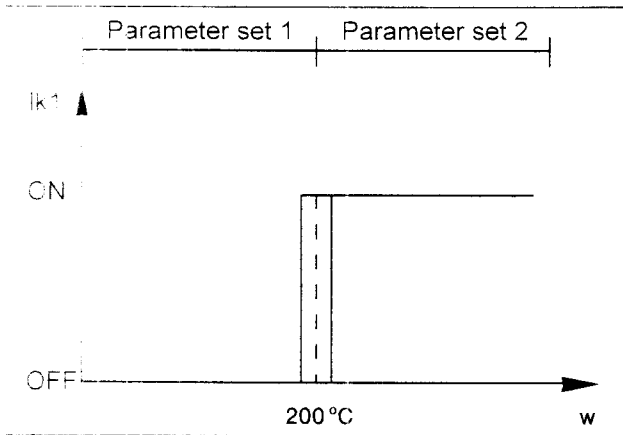

### Configuration level C1

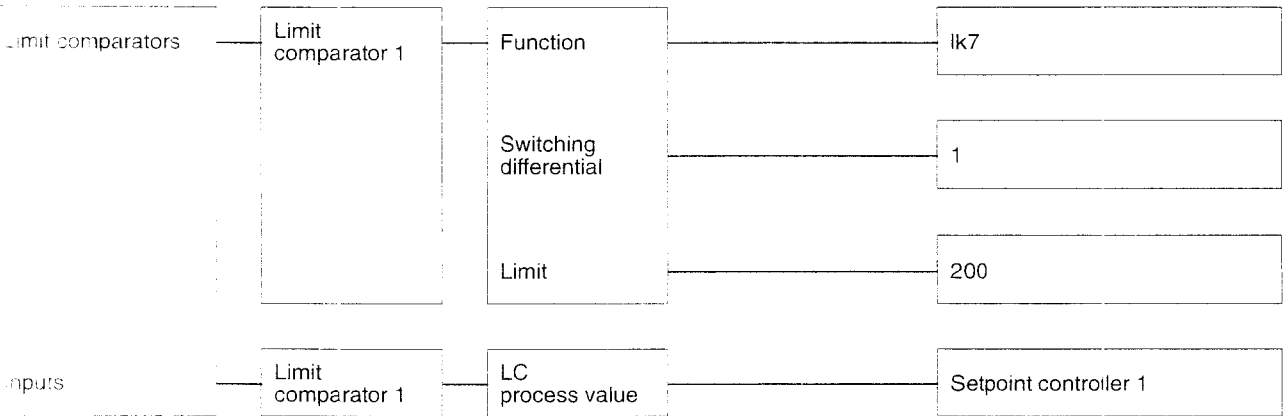

### Configuration level C2

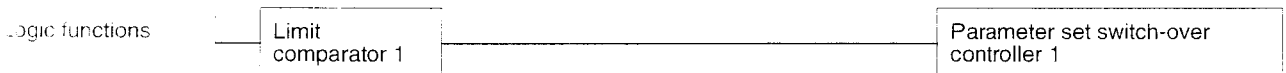

# 17 CONFIGURATION EXAMPLES

## 17.2 Cascade controller

Chocolate has to be heated to  $\vartheta_s = 40\text{ °C}$  for processing. The chocolate temperature must nowhere exceed  $50\text{ °C}$  (even close to the heater). It is therefore heated on a water bath.

Cascade control is used in order to achieve rapid stabilisation

Controller 1 is always the master controller, controller 2 always the slave controller.

The setpoint for the slave controller is produced by output conversion.

The control output  $y_1$  is converted to a setpoint using the unit of the process value  $x_2$  (here:  $0 - 100\% = 0 - 50\text{ °C}$ ).

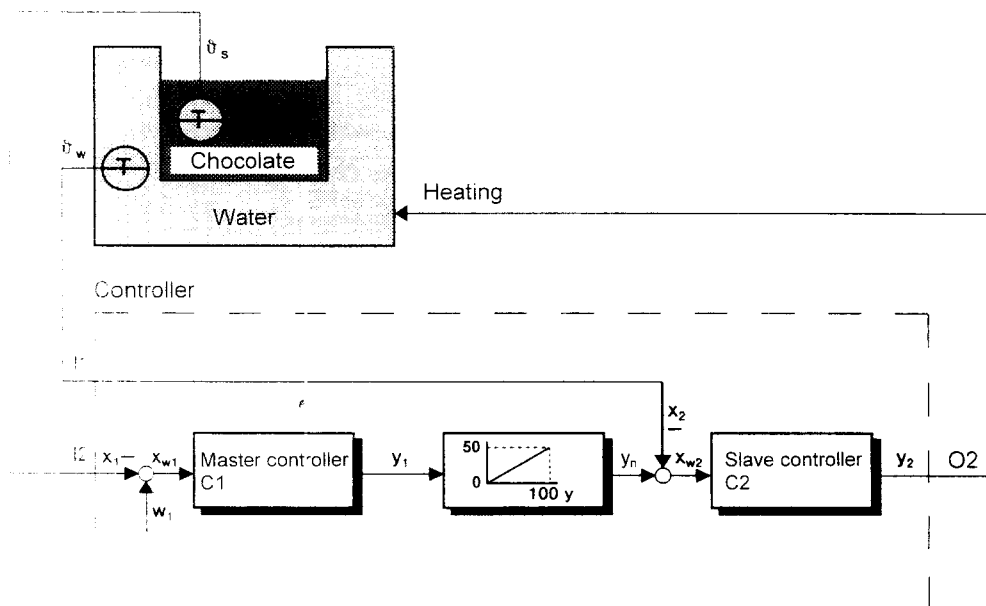

### List of symbols

- C1 - Controller 1
- C2 - Controller 2
- I1 - Analogue input 1
- I2 - Analogue input 2
- O2 - Output 2
- $w_1$  - Setpoint controller 1
- $x_1$  - Process value controller 1
- $x_2$  - Process value controller 2
- $x_{w1}$  - Deviation controller 1
- $x_{w2}$  - Deviation controller 2
- $y_1$  - Control output 1
- $y_2$  - Control output 2; output1 of controller 2
- $y_n$  - Converted control output 1
- $\vartheta_s$  - Chocolate temperature
- $\vartheta_w$  - Water bath temperature

# 17 CONFIGURATION EXAMPLES

## Cascade controller

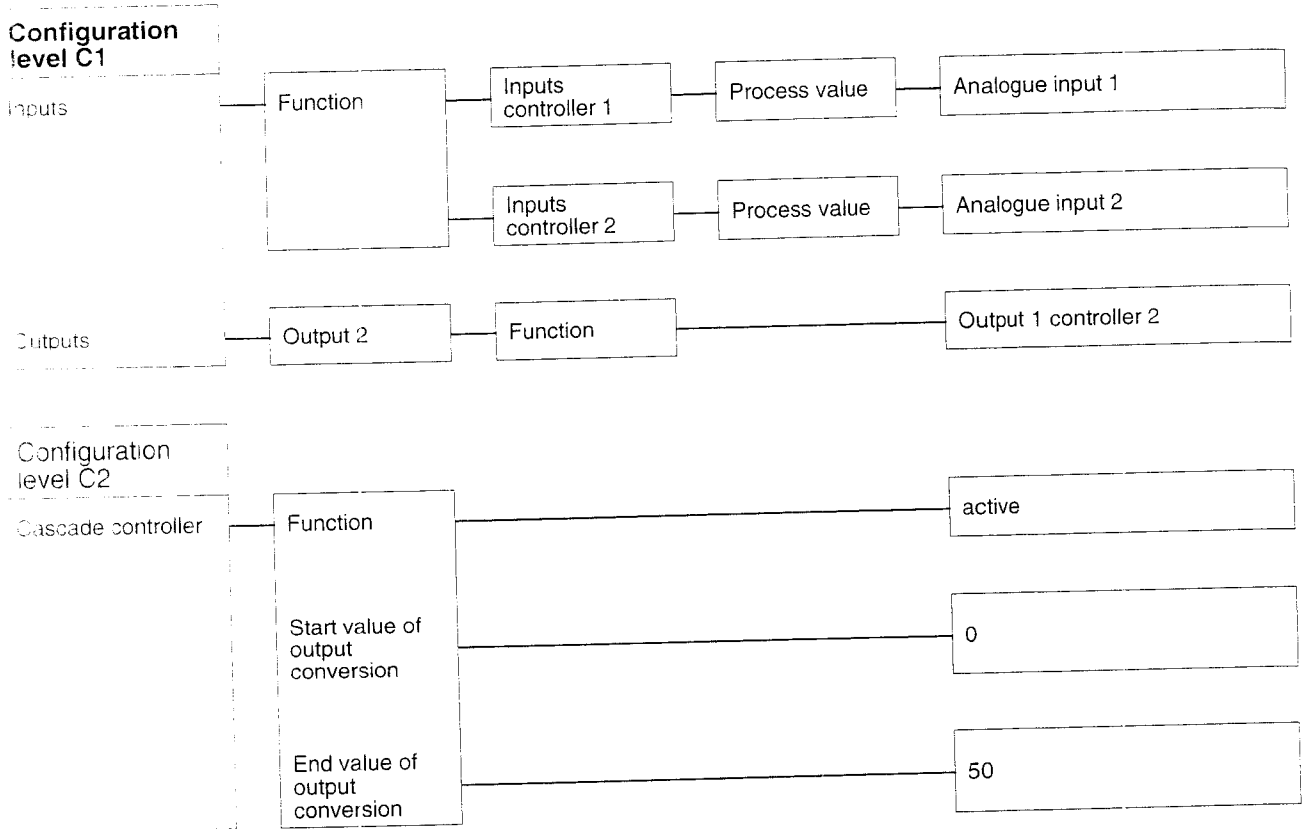

# 17 CONFIGURATION EXAMPLES

## 17.3 Trim cascade controller

Two patches of chocolate have to be heated to 40 °C and 50 °C. The chocolate temperature must nowhere (not even close to the heater) exceed the setpoint by more than 10 °C. It is therefore heated on a water bath.

Trim cascade control is used in order to achieve rapid stabilisation without overshoot, and without altering the controller configuration (output conversion) at a change in setpoint (batch change).

Controller 1 is always the master controller, controller 2 always the slave controller.

The setpoint for the slave controller is produced by output conversion and the addition of the master controller setpoint ( $w_1$ ).

In setpoint conversion, the control output  $y_1$  is converted to a value with the unit of the process value  $x_2$ . It corresponds to the maximum permitted temperature difference ( $\pm |x_1 - w_1|$ ; here: 0 — 100 % = -10 to +10 °C).



Using the maths module, the process value can be used to form the setpoint for the slave controller.

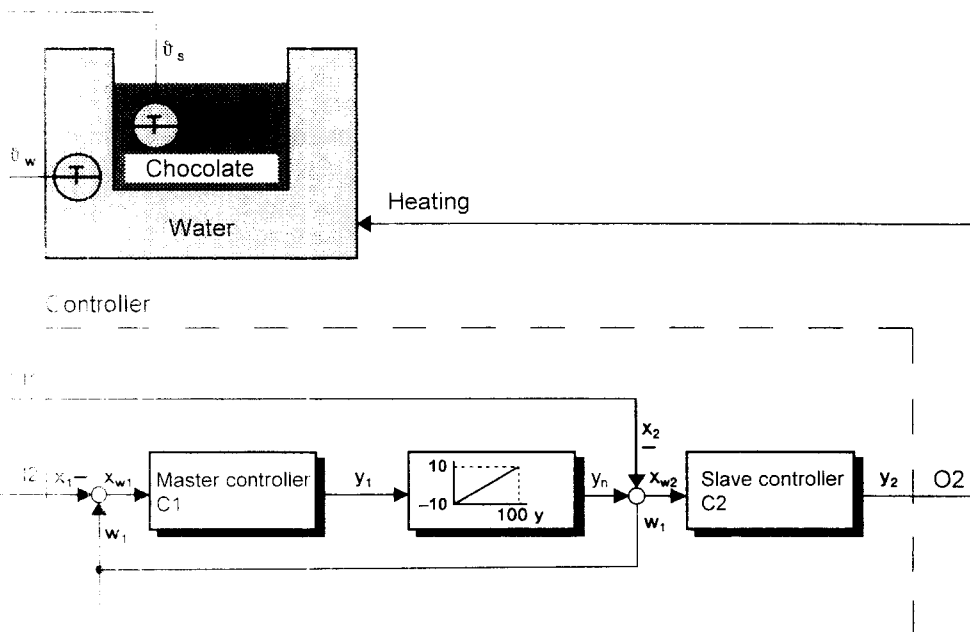

### List of symbols

- C1 → Controller 1
- C2 → Controller 2
- I1 → Analogue input 1
- I2 → Analogue input 2
- O2 → Output 2
- $w_1$  → Setpoint controller 1
- $x_1$  → Process value controller 1
- $x_2$  → Process value controller 2
- $x_{w1}$  → Deviation controller 1
- $x_{w2}$  → Deviation controller 2
- $y_1$  → Control output 1
- $y_2$  → Control output 2; output 1 of controller 2
- $y_n$  → Converted control output 1
- $\theta_s$  → Chocolate temperature
- $\theta_w$  → Water bath temperature

# 17 CONFIGURATION EXAMPLES

## Trim cascade controller

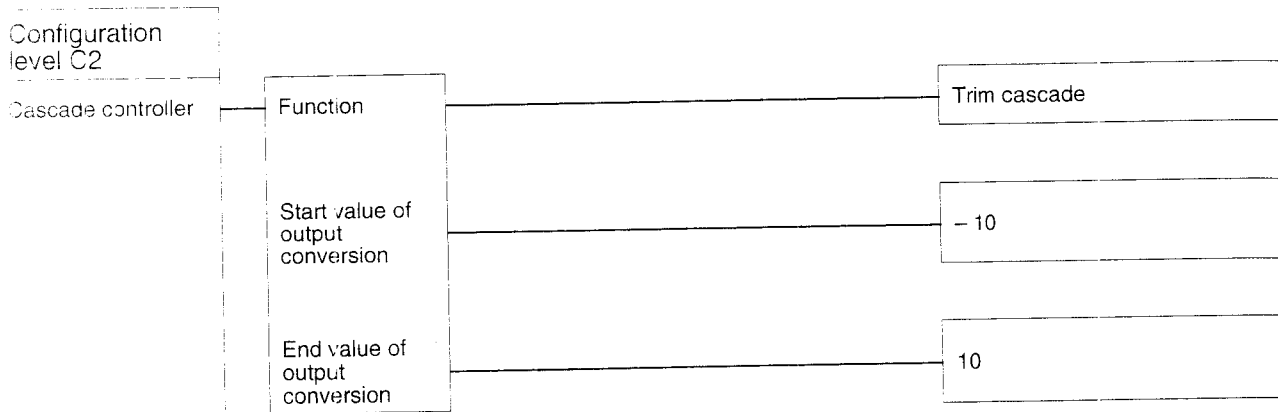
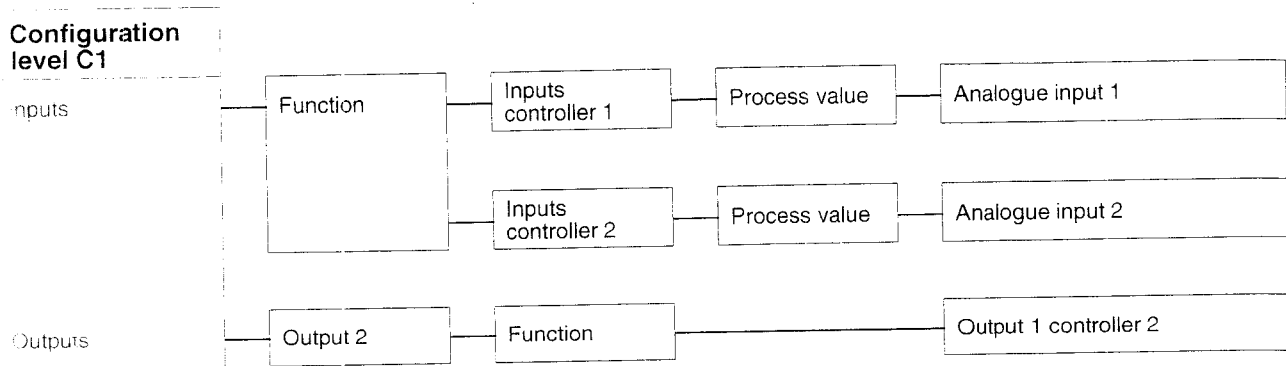

# 17 CONFIGURATION EXAMPLES

## 17.4 Difference controller

On precision machine tools (e.g. lathes) it is necessary to maintain tool, work and positioning device at the same temperature in order to ensure the required tolerances. This requirement can be met by thermostating the coolant using difference control

The coolant temperature and the temperature of the remaining equipment are fed to the maths module and the difference of the two values is applied to the controller structure as the controlled variable

System

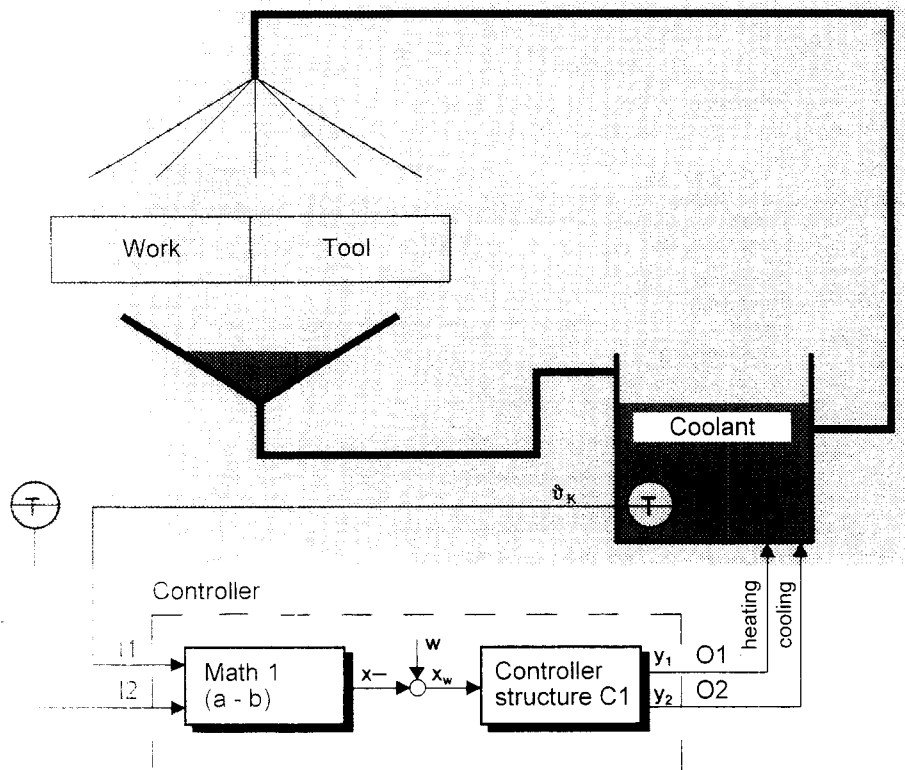

### List of symbols

- O1 - Controller 1
- I1 - Analogue input 1
- I2 - Analogue input 2
- O1 - Output 1
- O2 - Output 2
- w - Setpoint: required difference)
- x - Process value (controlled variable)
- x<sub>w</sub> - Deviation
- y<sub>1</sub> - Control output 1: Controller 1 output 1
- y<sub>2</sub> - Control output 2: Controller 1 output 2
- delta\_k - System temperature
- delta\_c - Coolant temperature

# 17 CONFIGURATION EXAMPLES

## Difference controller

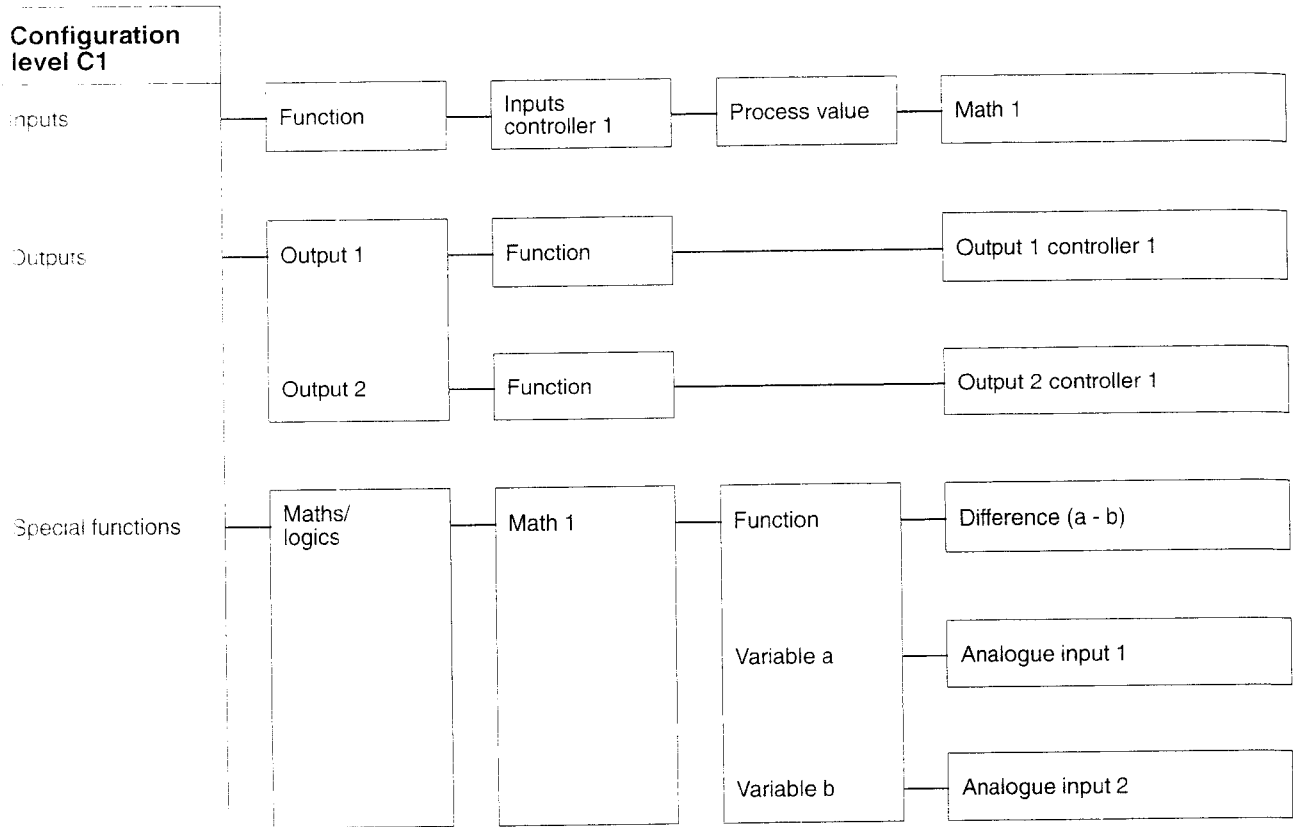

# 17 CONFIGURATION EXAMPLES

## 17.5 Ratio controller

Two substances a and b have to be mixed in a fixed ratio. The quantity b (setpoint  $w_2$ ) is controlled by the master controller C2. This controller also determines the total quantity ( $a + b$ ). Setpoint  $w_2$  is programmed as the setpoint input of controller 2.

The mixing ratio ( $a:b$ ) is determined by the ratio setpoint  $w_v$  which is programmed in the setpoint input of controller 1.



In the case of ratio control the maths module and the controller have a fixed internal linkage.

- Maths module 1 alters the setpoint of controller 1
- Maths module 2 alters the setpoint of controller 2

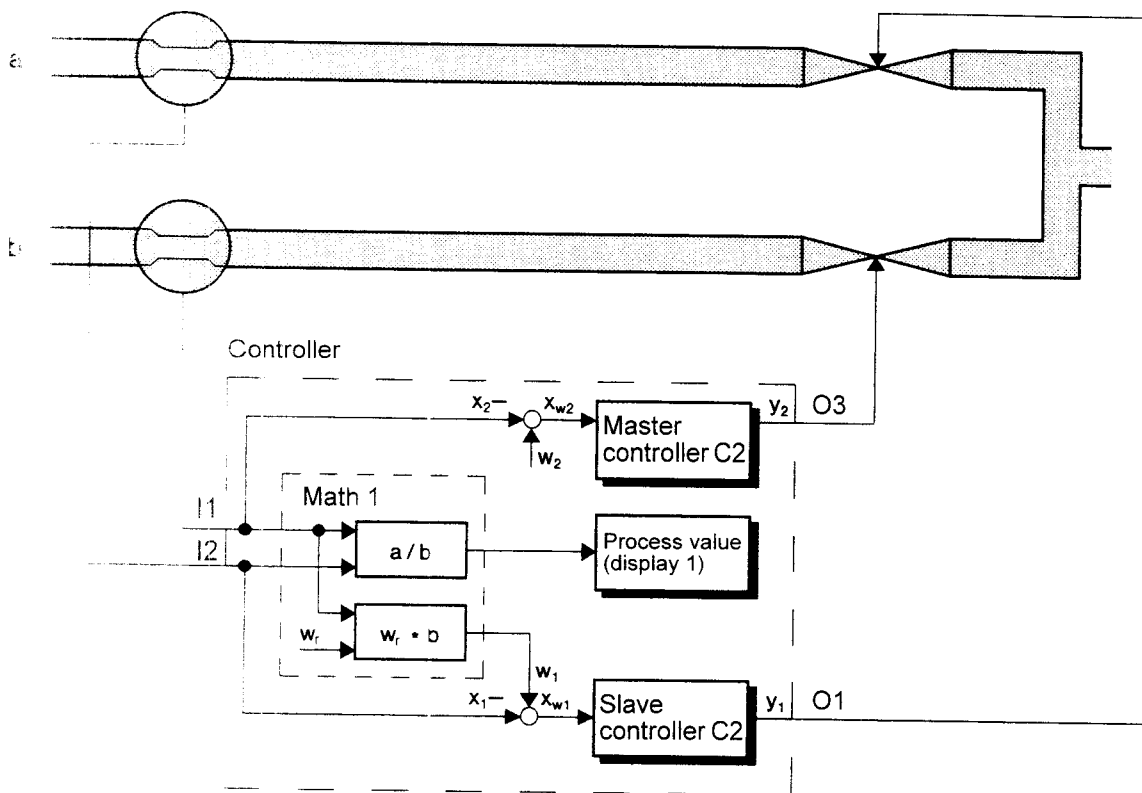

### List of symbols

- |       |                         |          |   |
|-------|-------------------------|----------|---|
| a     | - Quantity material a   | $w_2$    | - Setpoint controller 2                 |
| b     | - Quantity material b   | $w_v$    | - Ratio setpoint                        |
| O1    | - Controller 1          | $x_1$    | - Process value controller 1            |
| O2    | - Controller 2          | $x_2$    | - Process value controller 2            |
| I1    | - Analogue input 1      | $x_{w1}$ | - Deviation controller 1                |
| I2    | - Analogue input 2      | $x_{w2}$ | - Deviation controller 2                |
| O1    | - Output 1              | $y_1$    | - Control output 1: output controller 1 |
| O3    | - Output 3              | $y_2$    | - Control output 2: output controller 2 |
| $w_1$ | - Setpoint controller 1 |          |   |

# 17 CONFIGURATION EXAMPLES

## Ratio controller

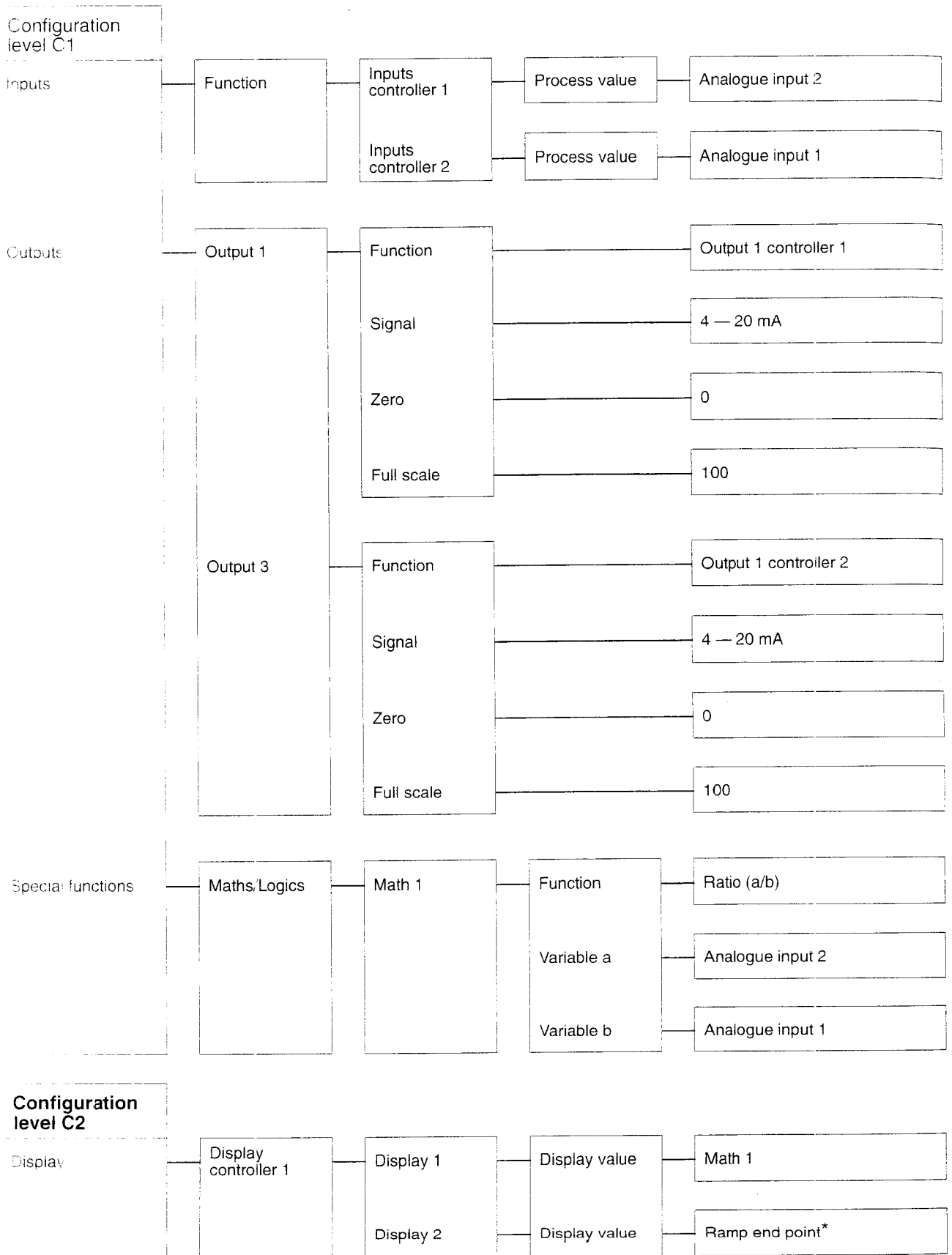

\* for ratio setpoint

# 17 CONFIGURATION EXAMPLES

## 17.6 Humidity controller

Humidity and the temperature have to be controlled in a climatic chamber. The humidity controller receives the process value with the aid of a psychrometric humidity sensor, using the mathematical linkage of wet and dry bulb temperature. The calculated process value can take values between 0 and 100 (% rH). The sensor also provides the process value (dry bulb temperature) for temperature control.

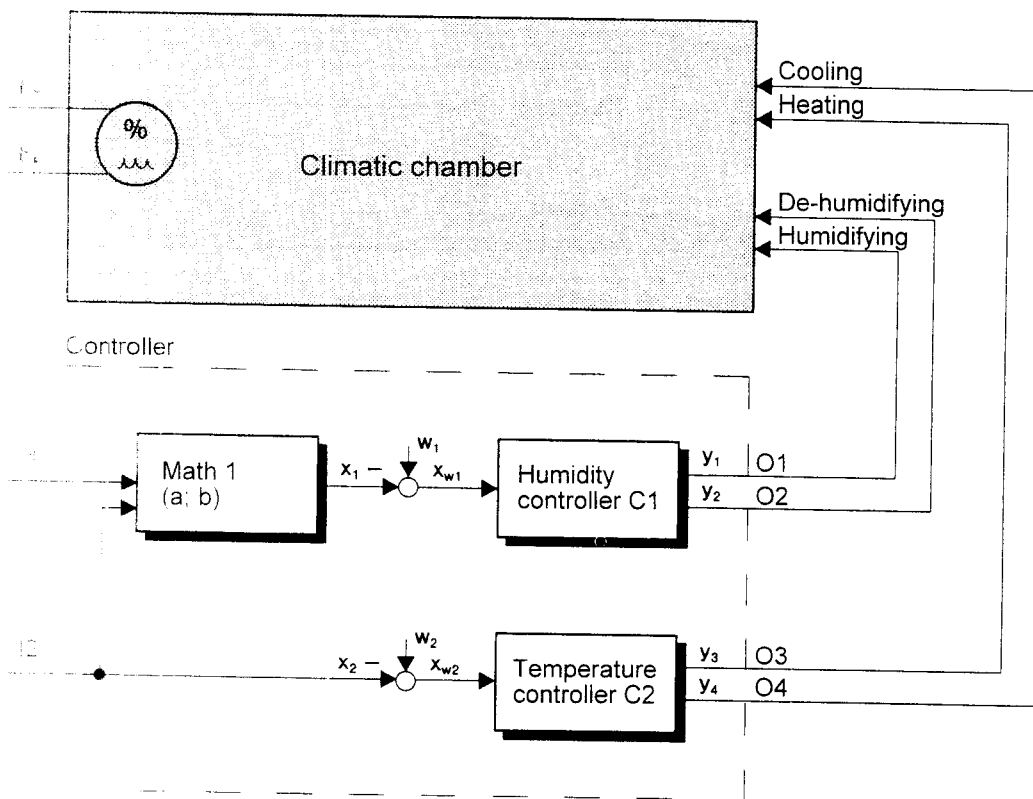

### List of symbols

- |                |                                       |                 |   |
|----------------|---------------------------------------|-----------------|---|
| C1             | – Controller 1                        | x1              | – Process value controller 1            |
| C2             | – Controller 2                        | x2              | – Process value controller 2            |
| I1             | – Analogue input 1                    | x <sub>w1</sub> | – Deviation controller 1                |
| I2             | – Analogue input 2                    | x <sub>w2</sub> | – Deviation controller 2                |
| O1             | – Output 1                            | y1              | – Control output 1: output controller 1 |
| O2             | – Output 2                            | y2              | – Control output 2: output controller 1 |
| O3             | – Output 3                            | y3              | – Control output 3: output controller 2 |
| O4             | – Output 4                            | y4              | – Control output 4: output controller 2 |
| w <sub>1</sub> | – Setpoint controller 1 (humidity)    | ϑ <sub>F</sub>  | – Wet bulb temperature                  |
| w <sub>2</sub> | – Setpoint controller 2 (temperature) | ϑ <sub>T</sub>  | – Dry bulb temperature                  |

# 17 CONFIGURATION EXAMPLES

## Humidity controller

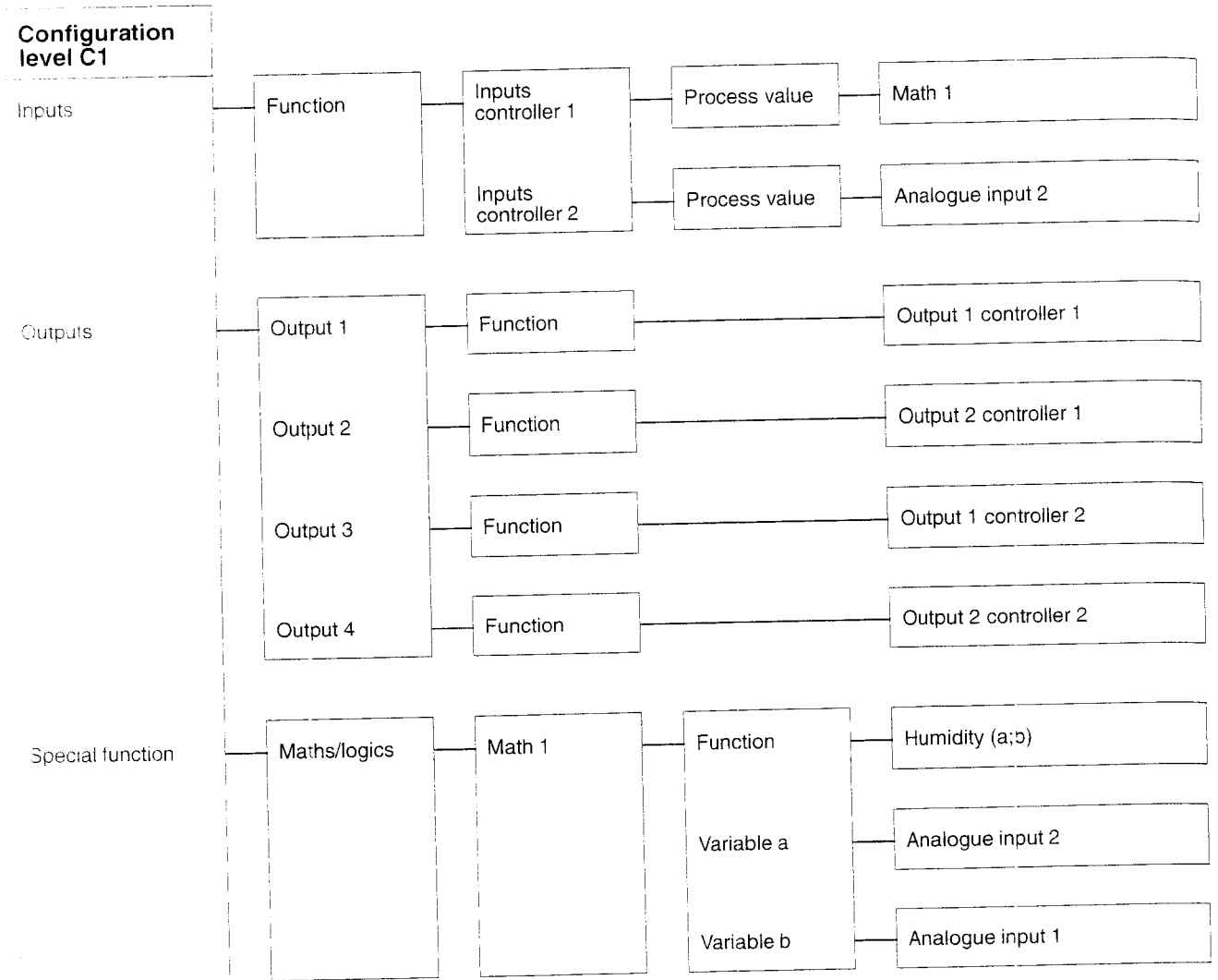

a = dry bulb temperature  
b = wet bulb temperature

# 17 CONFIGURATION EXAMPLES

## 17.7 Proportional controller with integral driver for motorised actuators

The supply temperature in a district heating scheme has to be controlled. A mixing valve is provided whose chambers W and C for warm and cold water are connected through pipes to the return water flow.

The outflow temperature is measured with a Pt 100 resistance thermometer and should be 55 °C. The temperature is varied by moving the slider S through an actuating motor whose position is retransmitted using a standard 0 — 20 mA signal

The input to the actuating motor consists of switching pulses from the actuator driver for opening or closing the valve ports. The proportional controller with integral driver for motorised actuators represents a cascade control system. The characteristic parameter of the actuating motor is its stroke time from one end stop of the slider to the other (stroke time  $TT = 90$  sec).

The subordinate circuit (driver controller) is optimised after the input of the stroke time into the controller.

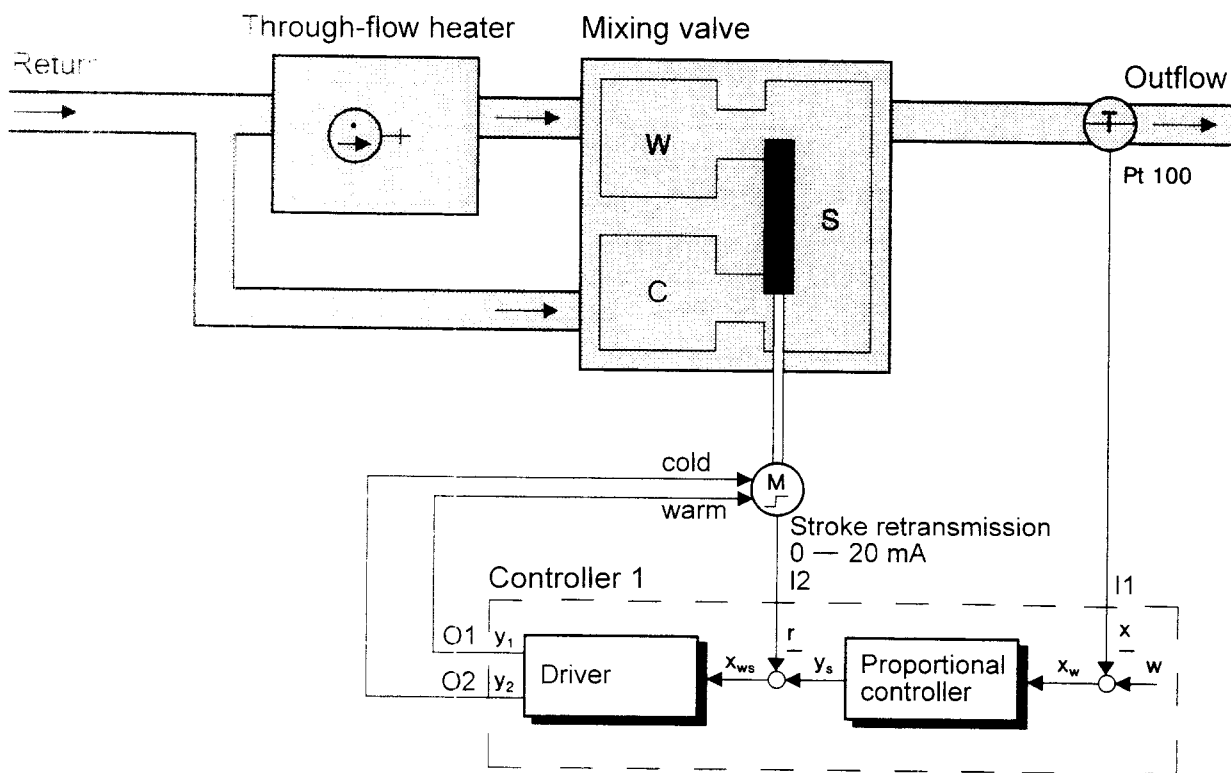

### List of symbols

- I1 — Analogue input 1
- I2 — Analogue input 2
- O1 — Output 1
- O2 — Output 2
- r — Stroke retransmission
- w — Setpoint
- x — Process value
- x<sub>v</sub> — Deviator
- x<sub>ws</sub> — Deviator (actuator driver)
- y<sub>s</sub> — Control output of proportional controller
- y<sub>1</sub> — Control output 1: output controller 1
- y<sub>2</sub> — Control output 2: output controller 1

# 17 CONFIGURATION EXAMPLES

## Proportional controller with integral driver for motorised actuators

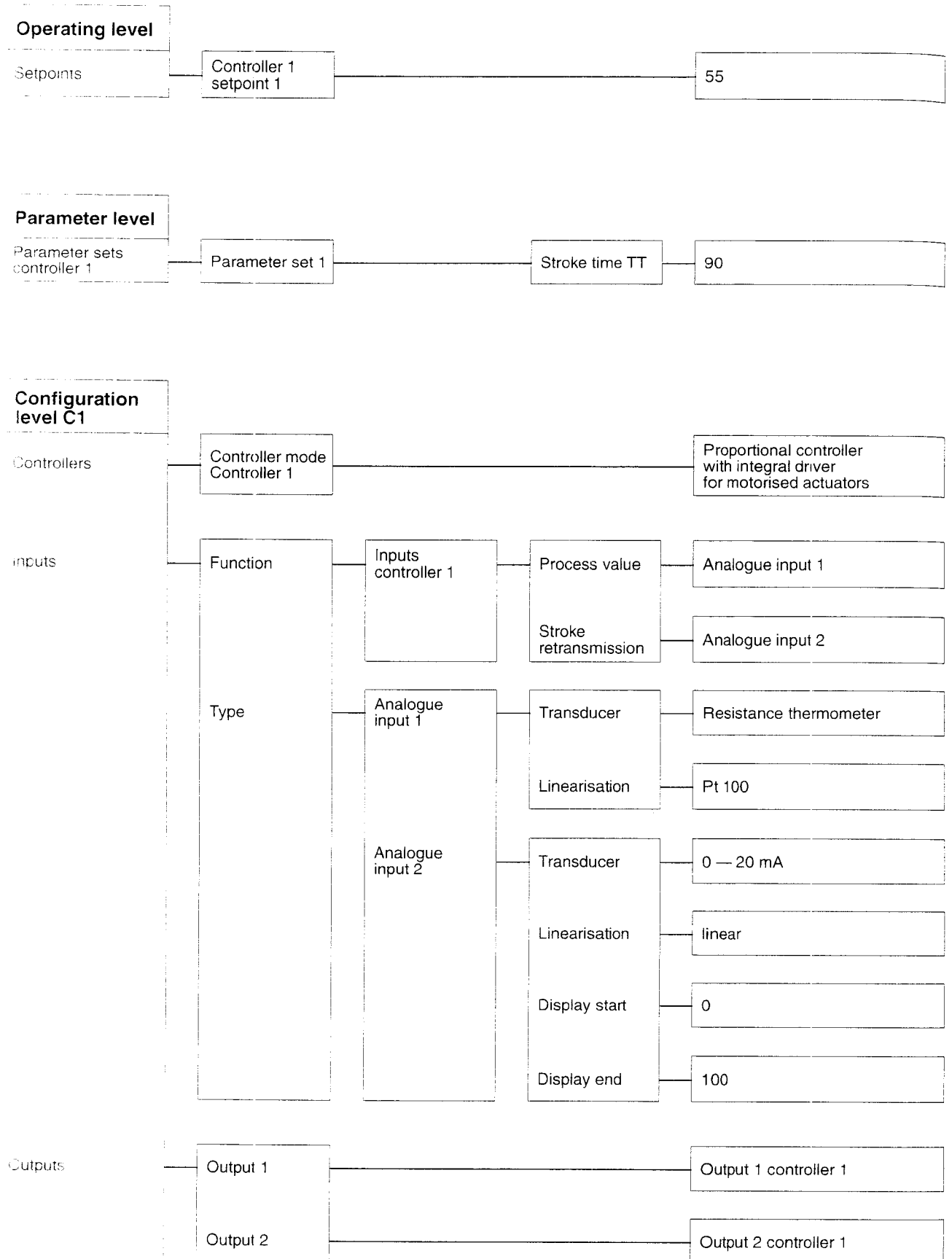

# 17 CONFIGURATION EXAMPLES

## 17.8 Controller with additive disturbance compensation

The liquid level in a tank with a rectangular base area  $A_B$  has to be held at 70 cm. The liquid level is disturbed by an outflow  $q_{out}$ . In order to achieve improved control action this outflow is being measured by a flowmeter whose signal is fed into the controller as an additive disturbance. As a result the controller alters its control output so that a change in the outflow is immediately compensated by a change in the inflow  $q_{in}$ . The inflow at maximum controller output is  $10 \times 10^{-3} \text{ m}^3/\text{sec}$ .

The tank has a height of 1.20 m. Since the supply pressure  $P_{in}$  is constant there is a proportional relationship between the controller output and the inflow rate.

The size of the additive disturbance is determined by a mean outflow of  $2 \times 10^{-3} \text{ m}^3/\text{sec}$ , corresponding to a current signal of 8 mA.

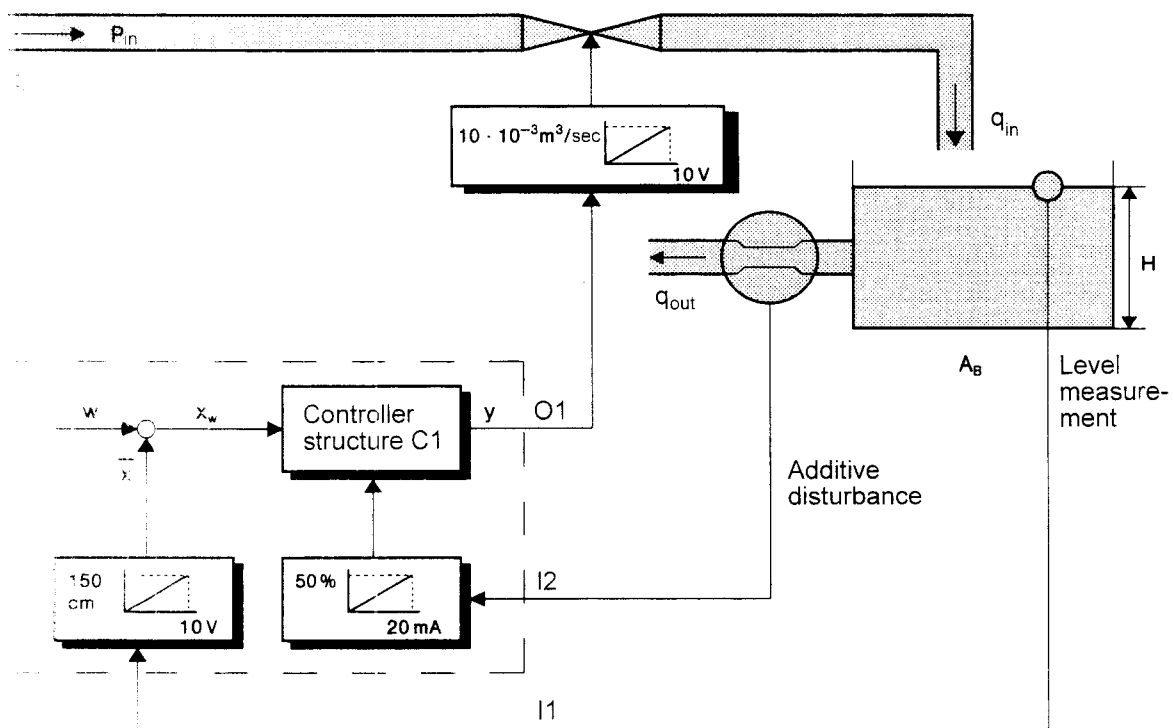

### List of symbols

- $A_B$  – Base area of the tank
- $C1$  – Controller 1
- $H$  – Height of tank
- $I1$  – Analogue input 1 (0 — 10 V)
- $I2$  – Analogue input 2 (0 — 20 mA)
- $O1$  – Output 1 (0 — 10 V)
- $P_{in}$  – Supply pressure
- $q_{in}$  – Inflow quantity
- $q_{out}$  – Outflow quantity
- $w$  – Setpoint
- $x$  – Process value
- $x_w$  – Deviation
- $y$  – Control output

# 17 CONFIGURATION EXAMPLES

## Controller with additive disturbance compensation

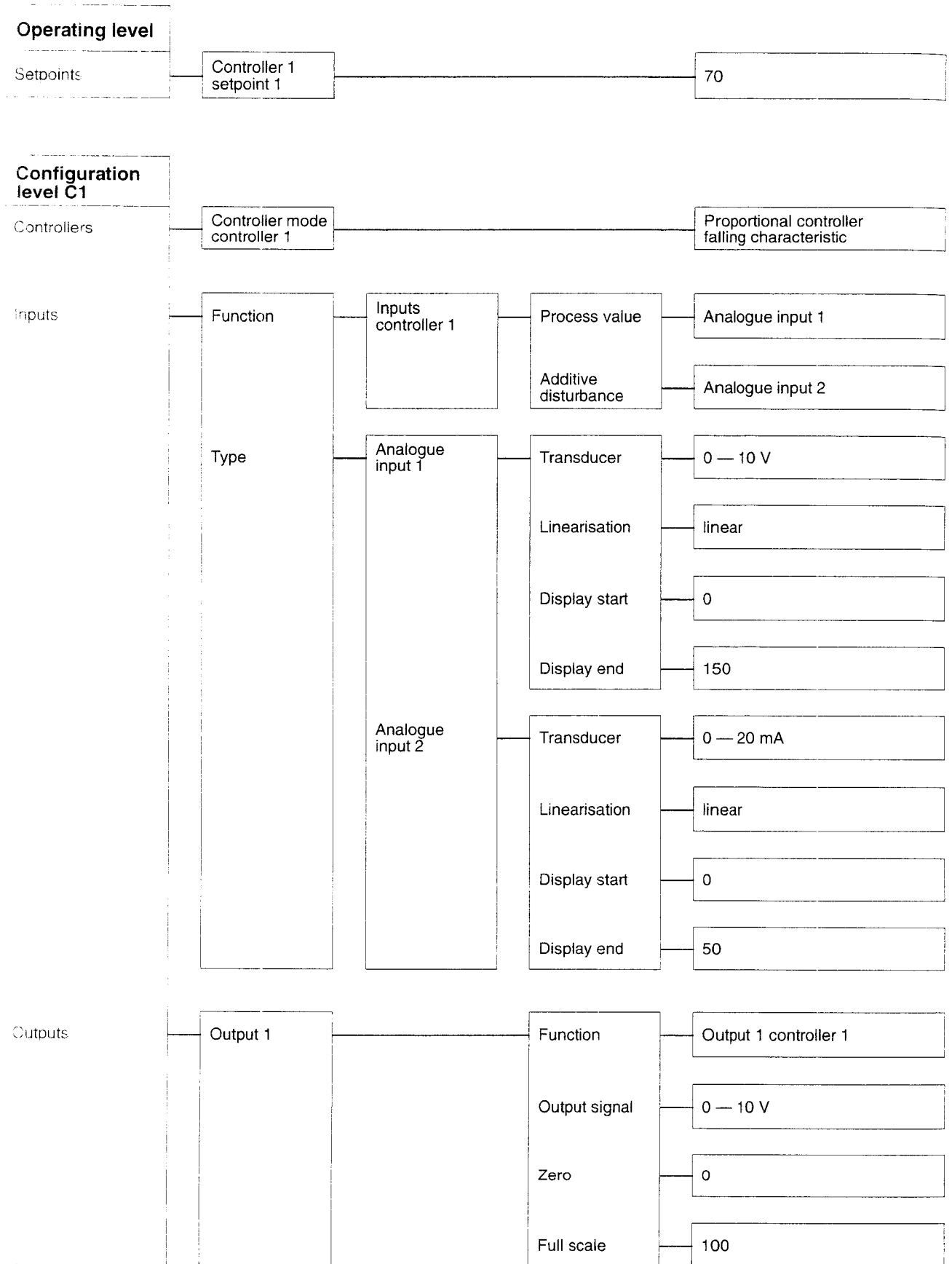

# 17 CONFIGURATION EXAMPLES

## 17.9 Controller with multiplying disturbance compensation

A liquid is passing through a pipe at a flow rate which can vary between 0 and 0.1 m<sup>3</sup>/sec. The liquid has to be heated to 200 °C by a heater.

The effect on the control of fluctuations in the volumetric flow rate are compensated by a multiplying disturbance correction. The controller is configured so that the disturbance  $z$  has a value of 100 % at the mid-point of operation (average volumetric flow rate 0.05 m<sup>3</sup>/sec).

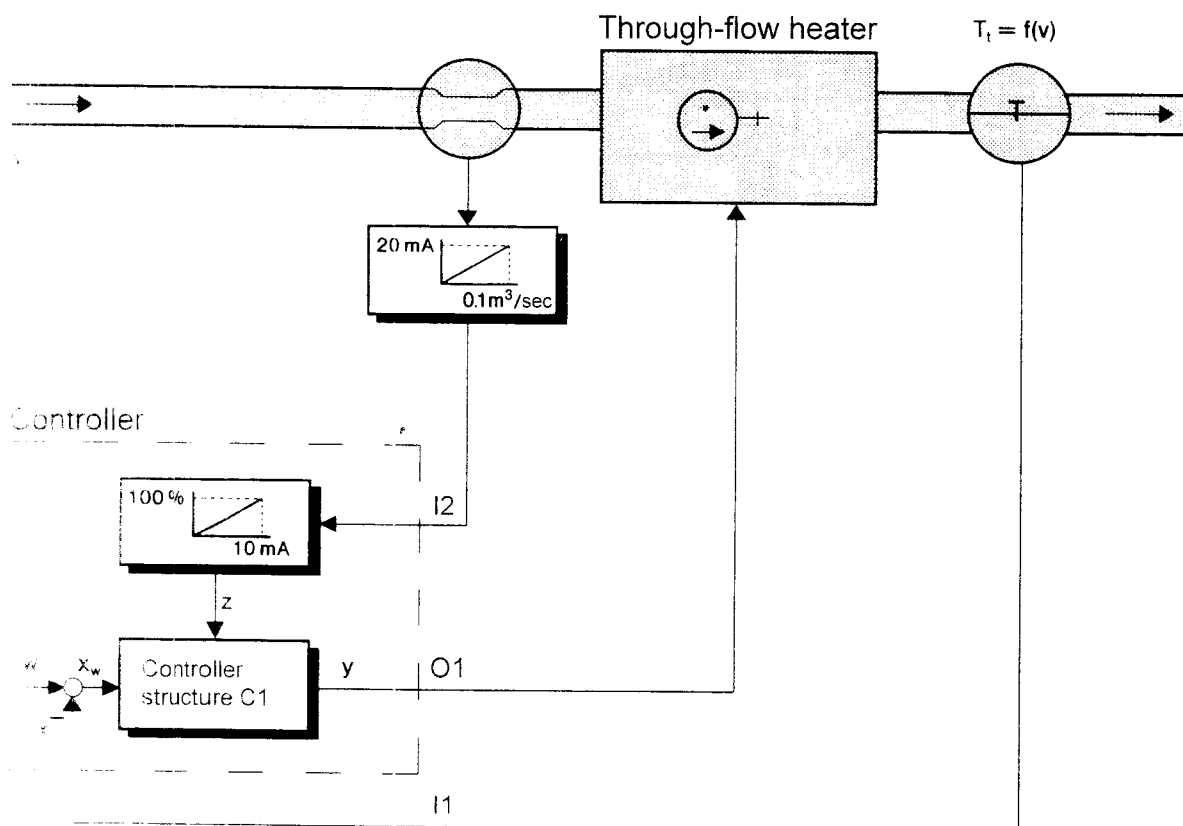

### List of symbols

- C1 - Controller 1
- I1 - Analogue input 1 (Pt 100)
- I2 - Analogue input 2 (0 — 20 mA)
- O1 - Output 1 (0 — 10 V)
- $v$  - Volumetric flow rate
- $w$  - Setpoint
- $x$  - Process value
- $x_w$  - Deviation
- $y$  - Control output
- $z$  - Disturbance

# 17 CONFIGURATION EXAMPLES

## Controller with multiplying disturbance compensation

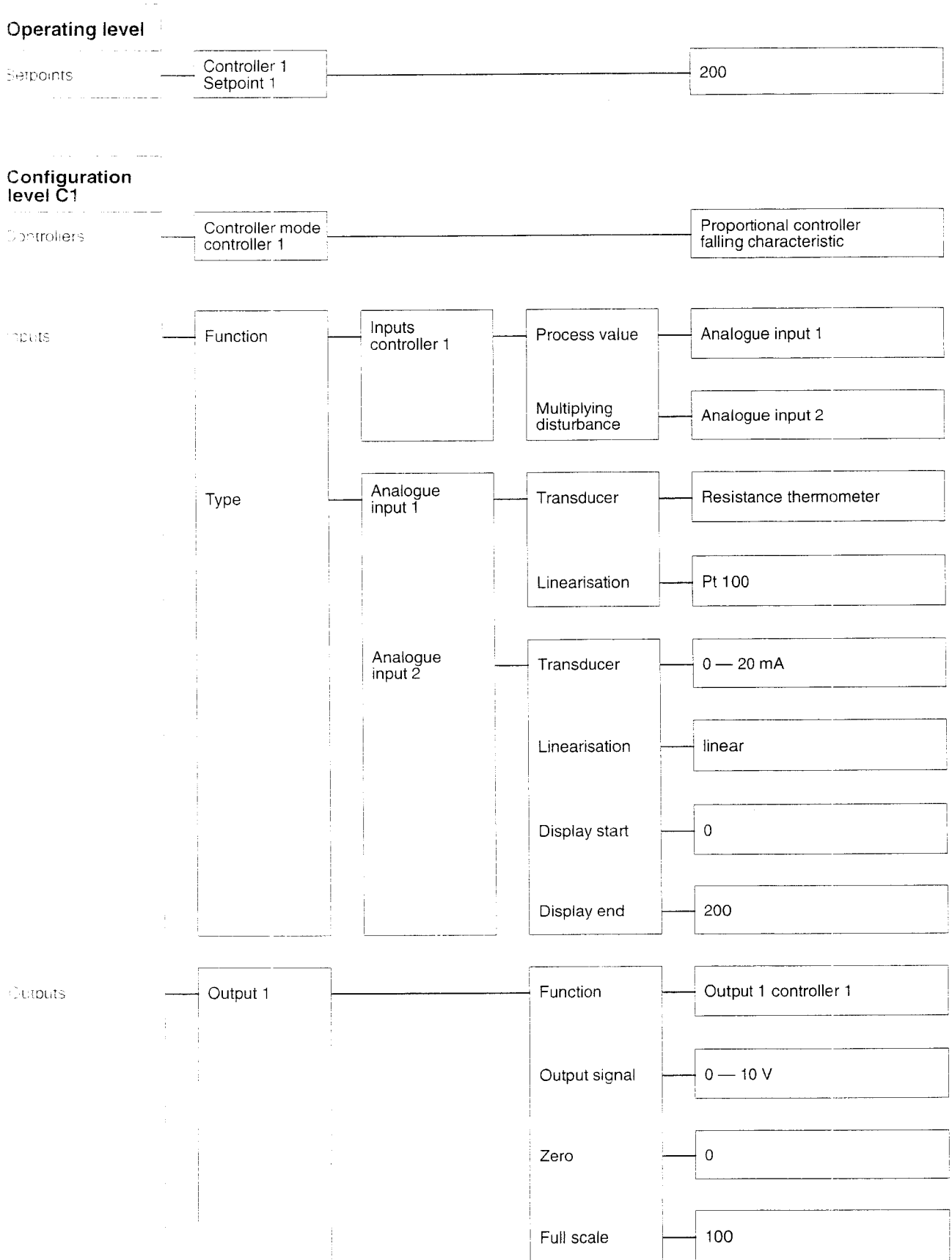

# 17 CONFIGURATION EXAMPLES

## 17.10 Controller with limit comparator and text display

A furnace is controlled by a temperature controller. The actual temperature  $x$  must not fall below the setpoint  $w = 1000\text{ }^{\circ}\text{C}$  by more than  $20\text{ }^{\circ}\text{C}$ .



The text display can only be programmed using the setup program (accessory).

If the difference between setpoint and actual temperature is larger, an alarm (hooter) has to be produced (the relay of output O2 has to pull in) and the matrix display has to show the text "TEMPERATURE LOW".

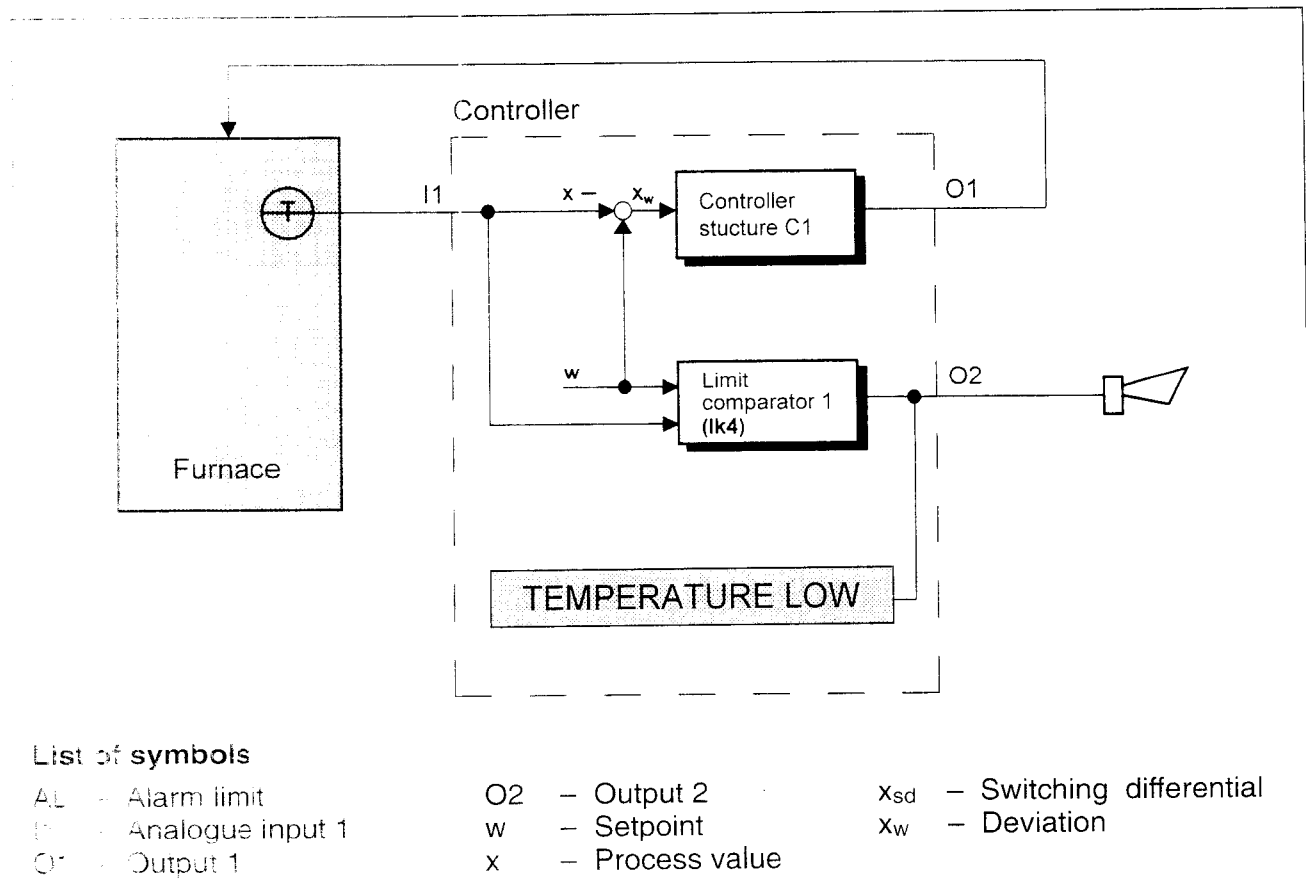
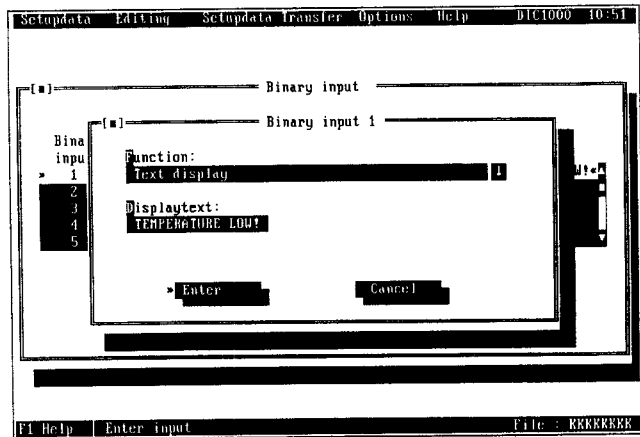
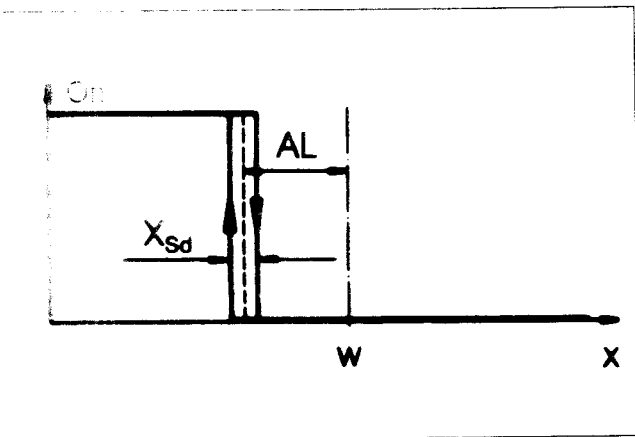

### List of symbols

AL – Alarm limit  
 $I1$  – Analogue input 1  
 $O1$  – Output 1

$O2$  – Output 2  
 $w$  – Setpoint  
 $x$  – Process value

$x_{sd}$  – Switching differential  
 $x_w$  – Deviation

# 17 CONFIGURATION EXAMPLES

## Controller with limit comparator and text display

### Configuration level C1

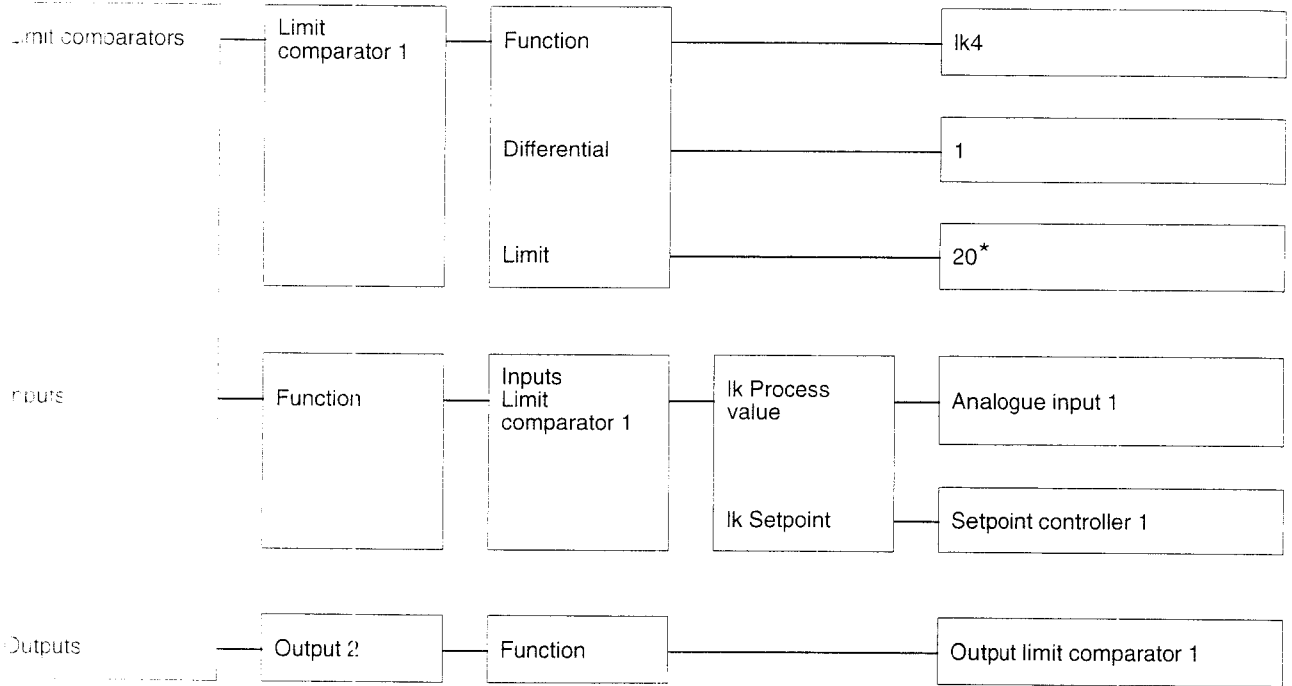

### Configuration level C2

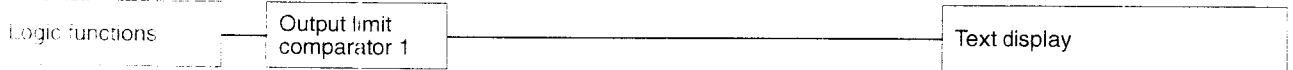

\* Switching differential  $X_{sd}$  neglected

# 17 CONFIGURATION EXAMPLES

## 17.11 Controller with heater current monitoring

In electrically heated ovens and furnaces it may be useful in the case of several heater circuits to monitor the heating current in order to determine whether one circuit has failed.

In the example the normal heating current is 100 A. If one of the heater circuit fails, the heating current is reduced to approx. 67 A.

The heating current is evaluated by a current transformer with a standard output signal (0 — 100 A AC → 0 — 20 mA AC).

The measurement is made when the heating contact is closed. A limit comparator (Ik8) can be used to signal when the current falls below a certain limit (AL = 70).

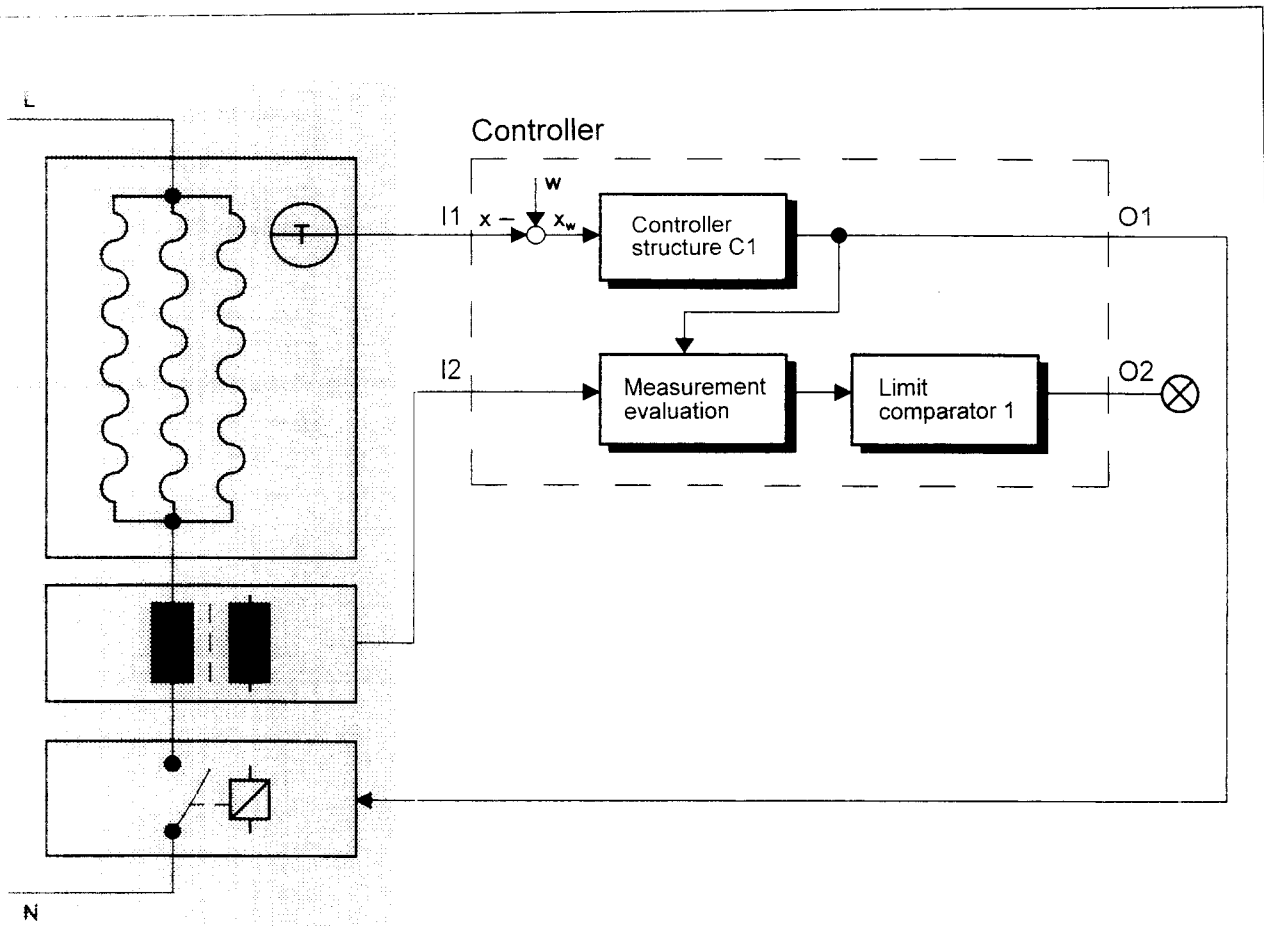

### List of symbols

- I1 - Analogue input 1
- I2 - Analogue input 2
- O1 - Output 1
- O2 - Output 2
- w - Setpoint
- x - Process value
- x<sub>w</sub> - Deviation

# 17 CONFIGURATION EXAMPLES

## Controller with heater current monitoring

Configuration level C1

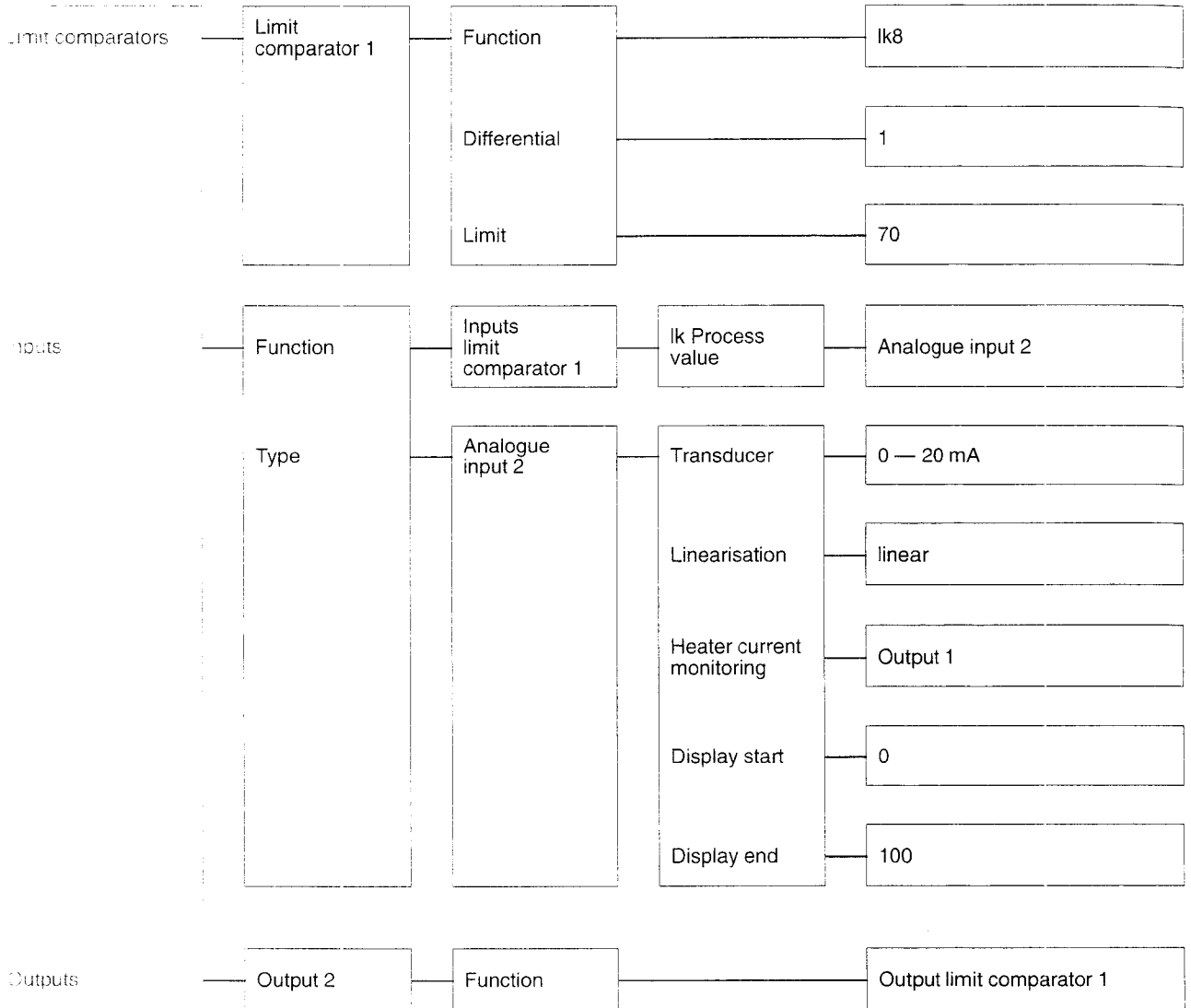

# 17 CONFIGURATION EXAMPLES

## 17.12 Controller with maths module

The scheme represents a flow control. A flow-meter provides a differential pressure  $\Delta p$  as the measured value. The flow  $q$  can be calculated from the following formula:

$$q = k * \sqrt{\Delta p}$$



The formula can only be input in the setup program.

### Math formula

Formula 1:

**1.5 \* SQRT (AIN1)**

Formula 2:

[Redacted]

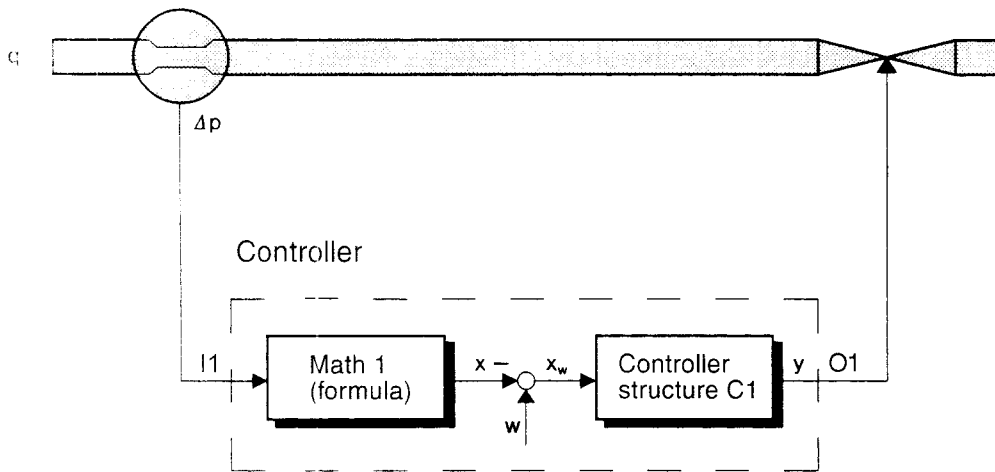

### List of symbols

- |    |                                  |            |   |
|----|----------------------------------|------------|---|
| I1 | - Analogue input 1               | x          | - Process value                         |
| k  | - Constant (depending on system) | $x_w$      | - Deviation                             |
| O1 | - Output 1                       | y          | - Control output: output 1 controller 1 |
| w  | - Setpoint                       | $\Delta p$ | - Pressure difference                   |

### Configuration level C1

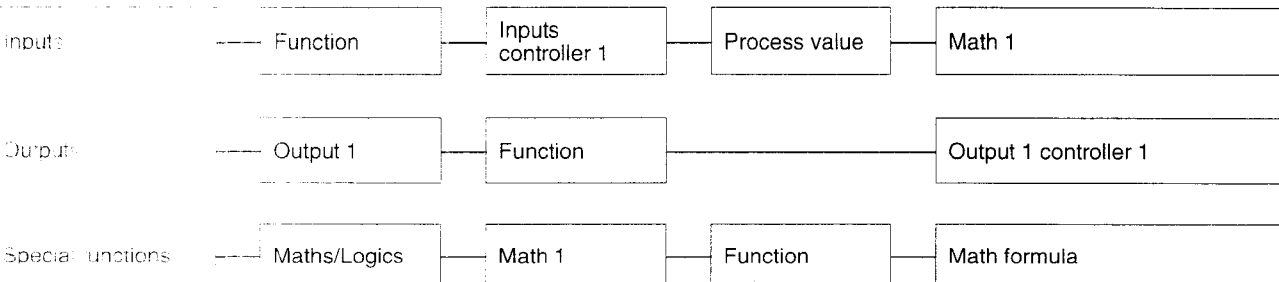

# 17 CONFIGURATION EXAMPLES

## 17.13 C-level controller

The task is to control the carbon level in the atmosphere of a carburisation furnace and the furnace temperature. The values which are required for the C-level control are measured by a zirconium dioxide sensor and a CO analyser.

The furnace temperature is measured by a thermocouple.

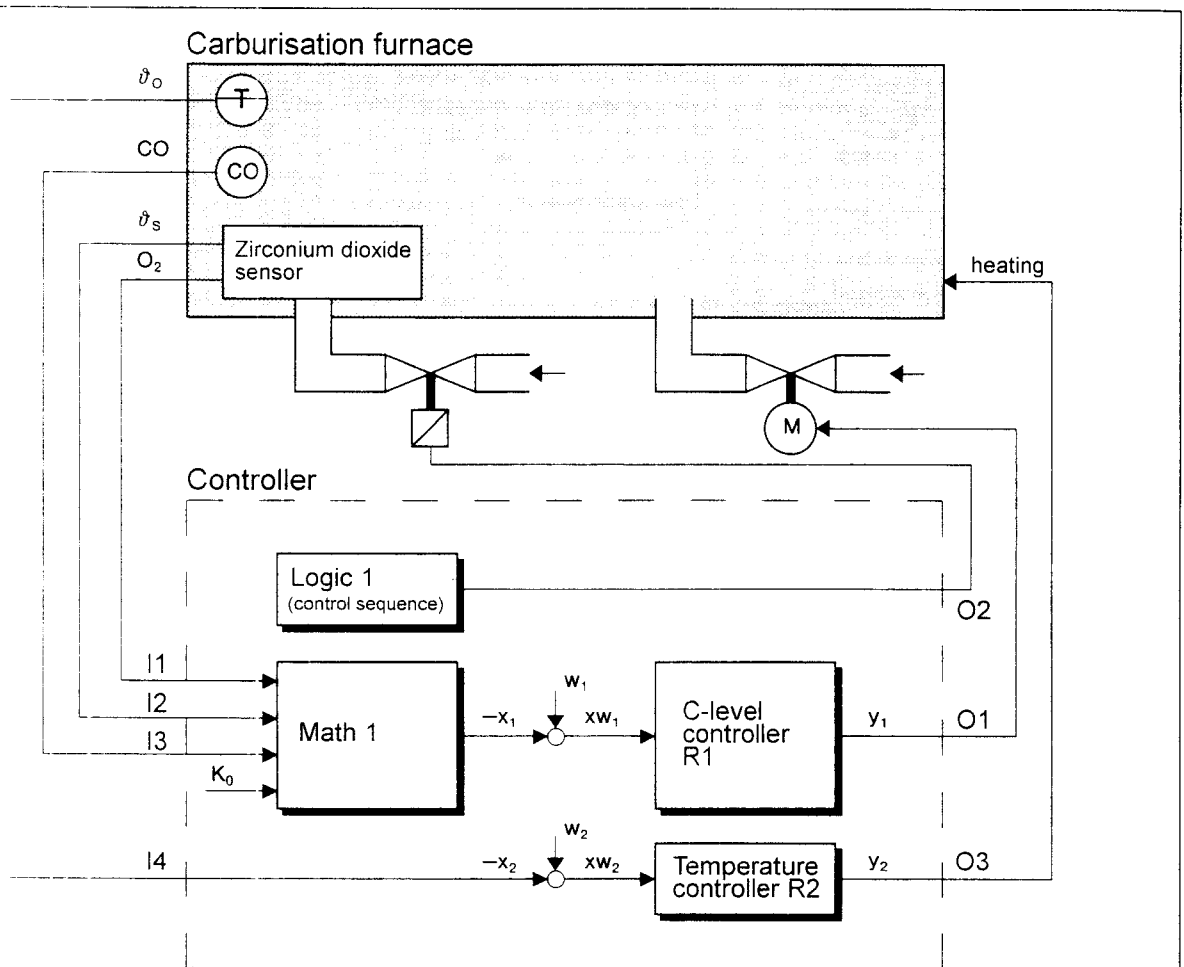

### List of symbols

CO	- Carbon monoxide concentration	O1	- Output 1	$x_2$	- Process value, contr. 2
I1	- Analogue input 1	O2	- Output 2	$x_{w1}$	- Deviation, contr. 1
I2	- Analogue input 2	O3	- Output 3	$x_{w2}$	- Deviation, contr. 2
I3	- Analogue input 3	$O_2$	- Oxygen level	$y_1$	- Control output, contr. 1
I4	- Analogue input 4	$w_1$	- Setpoint controller 1	$y_2$	- Control output, contr. 2
$K_0$	- Furnace correction	$w_2$	- Setpoint controller 2	$\vartheta_o$	- Furnace temperature
		$x_1$	- Process value, contr. 1	$\vartheta_s$	- Sensor temperature

# 17 CONFIGURATION EXAMPLES

## C-level controller

### C-level menu

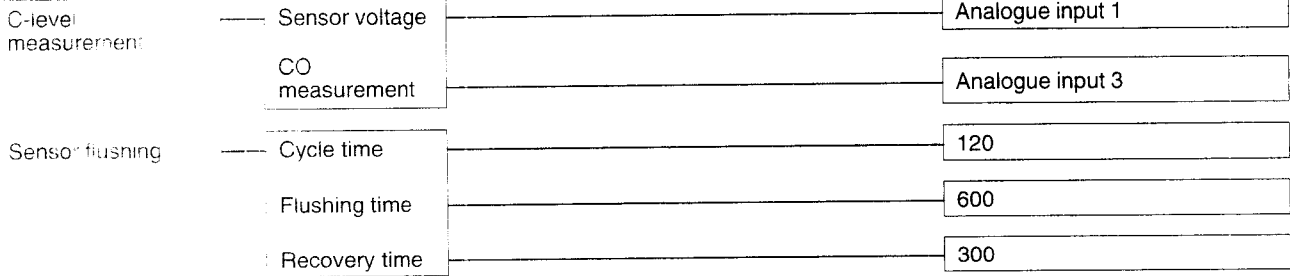

### Configuration level C1

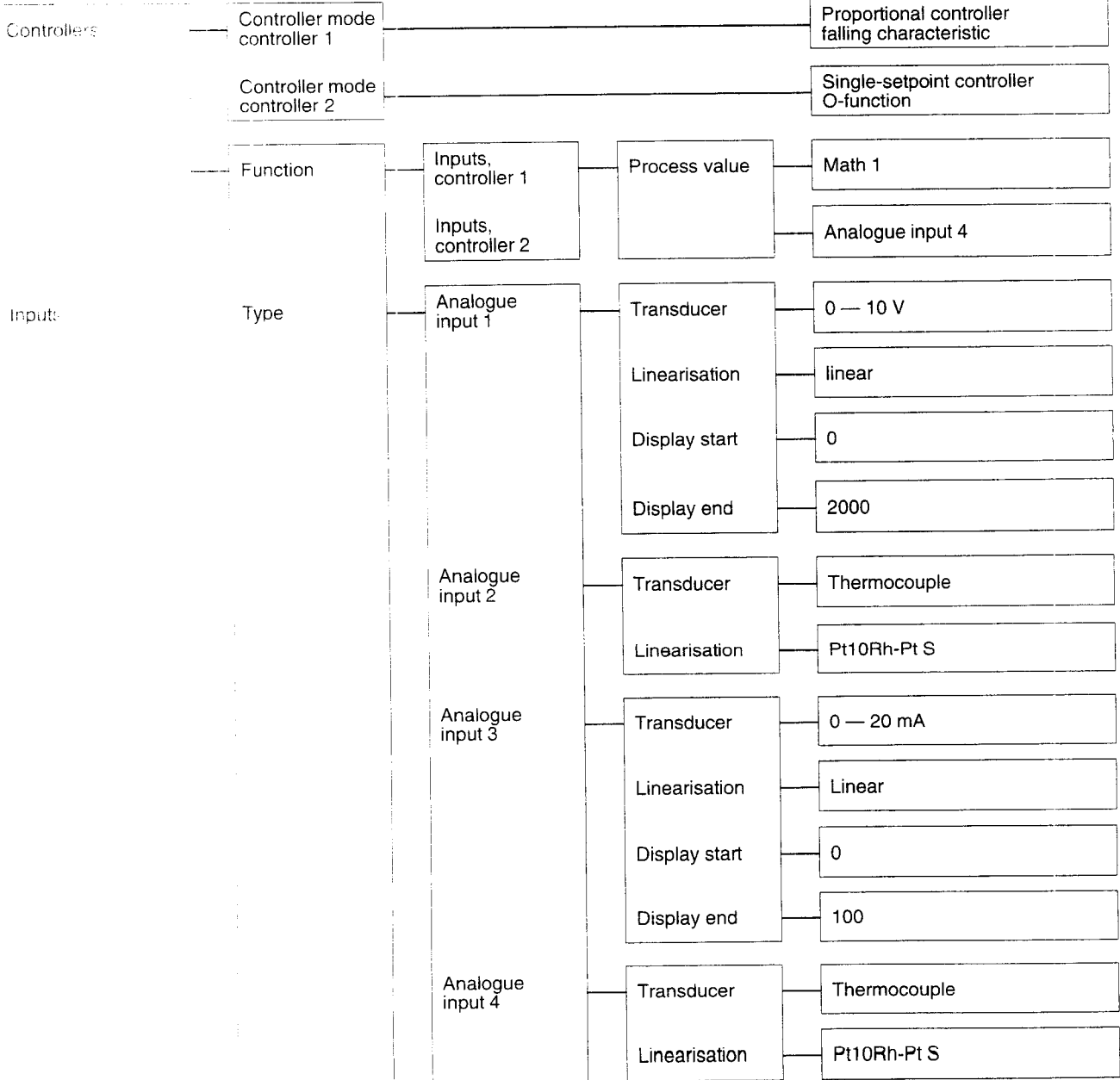

# 17 CONFIGURATION EXAMPLES

## C-level controller

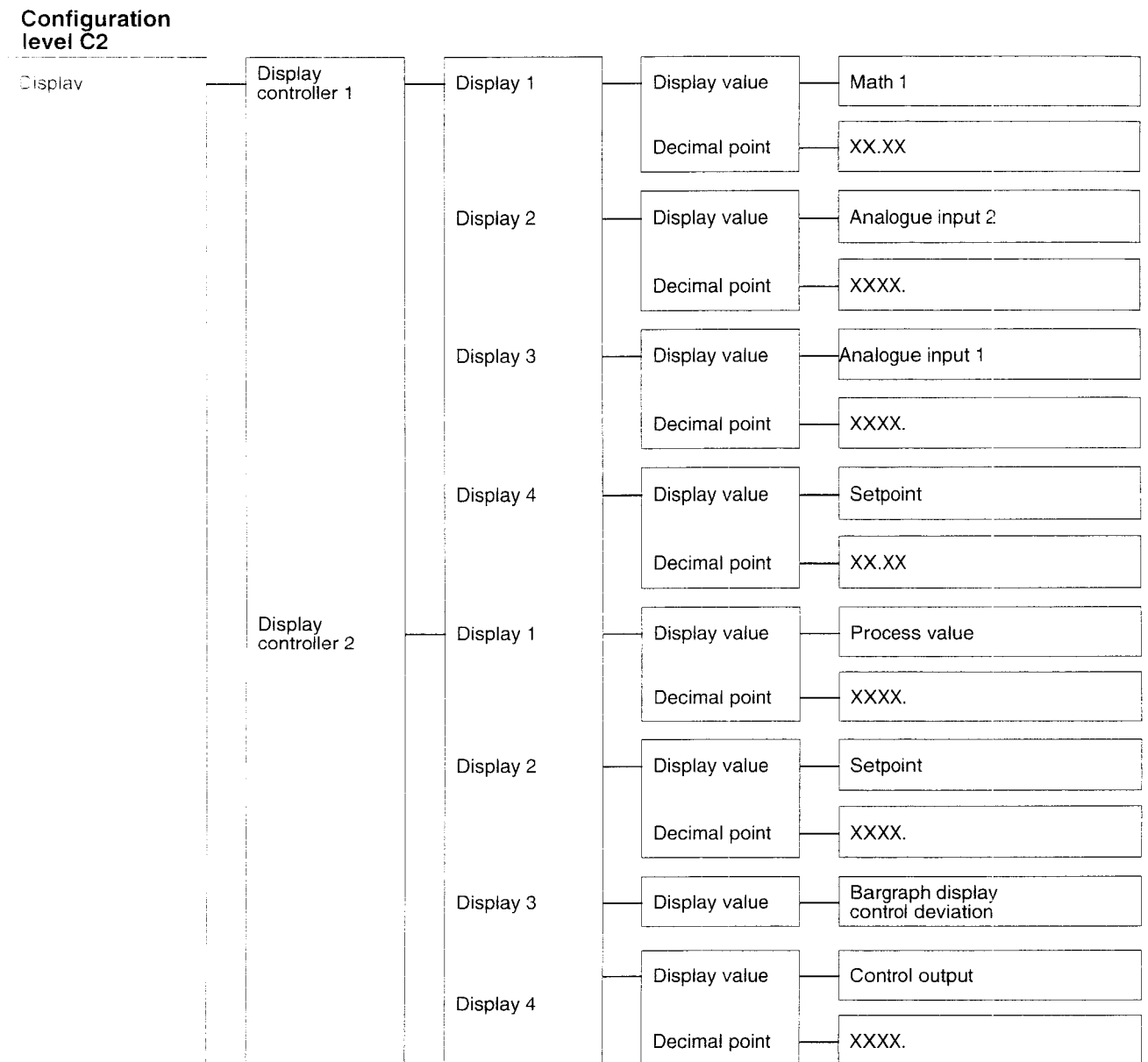
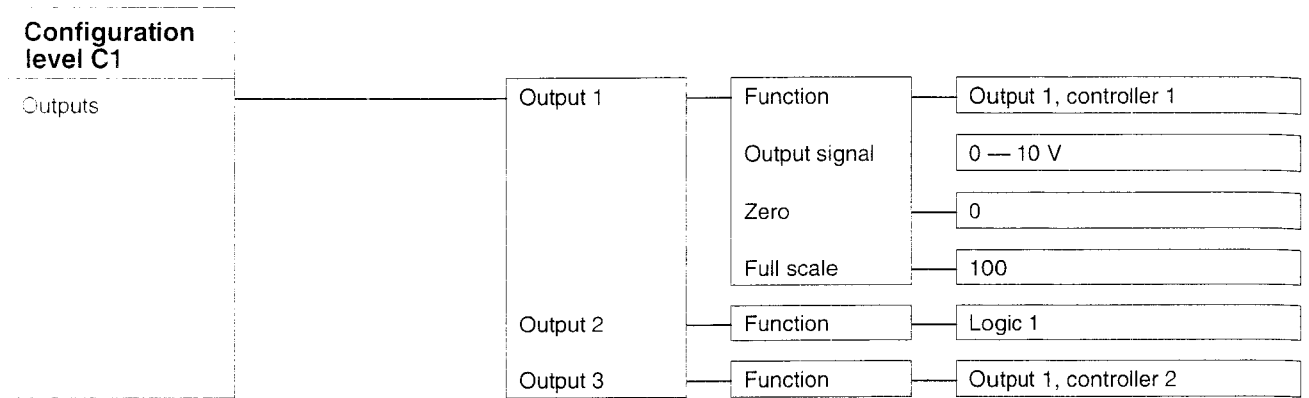

# 18 RETROFITTING OF CARDS

In case a controller has to be extended or modified, a variety of retrofit cards (assemblies) are available. They are summarised at the end of the chapter and can be ordered individually.

The operations to change the cards are described below.



The cards can be damaged by electrostatic discharges. Avoid electrostatic charges during fitting and removal. Carry out the card change on a workbench which is grounded.



Cards must be retrofitted only by suitably qualified personnel.

## Pulling off the PC interface plug



The plug is located at the top of the controller when it is linked to a PC.

- \* Pull off the plug upwards.

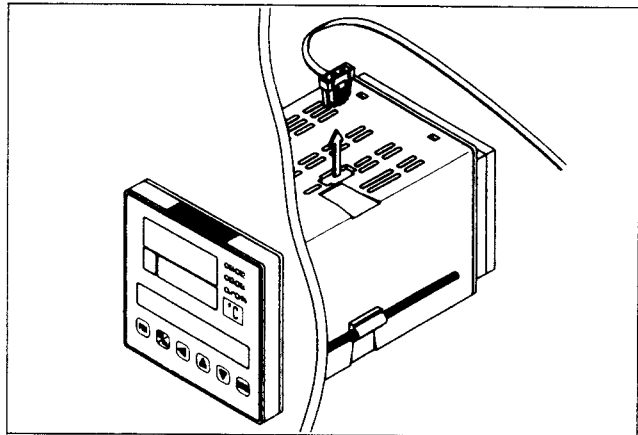

## Pulling out the controller chassis

- \* Grasp the front panel by the corrugated areas (top and bottom), press them together and pull out the controller chassis.

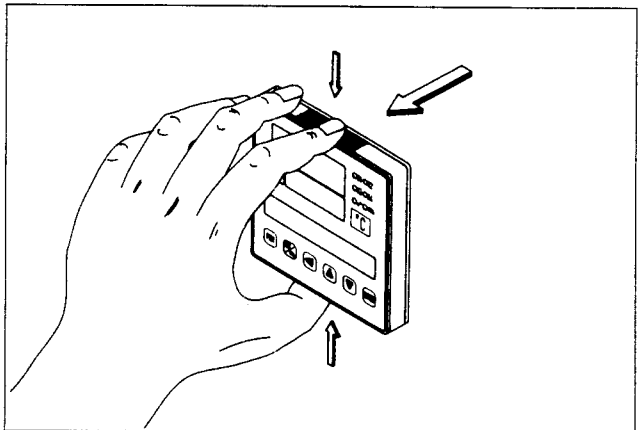

## Removing the insulating and guide plates

- \* Take off the insulating plate
- \* Release the four retaining clips engaging with the outer cards and pull off the guide plate.

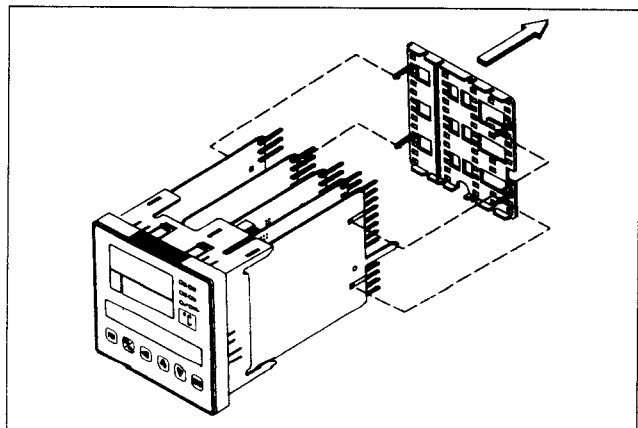

# 18 RETROFITTING OF CARDS

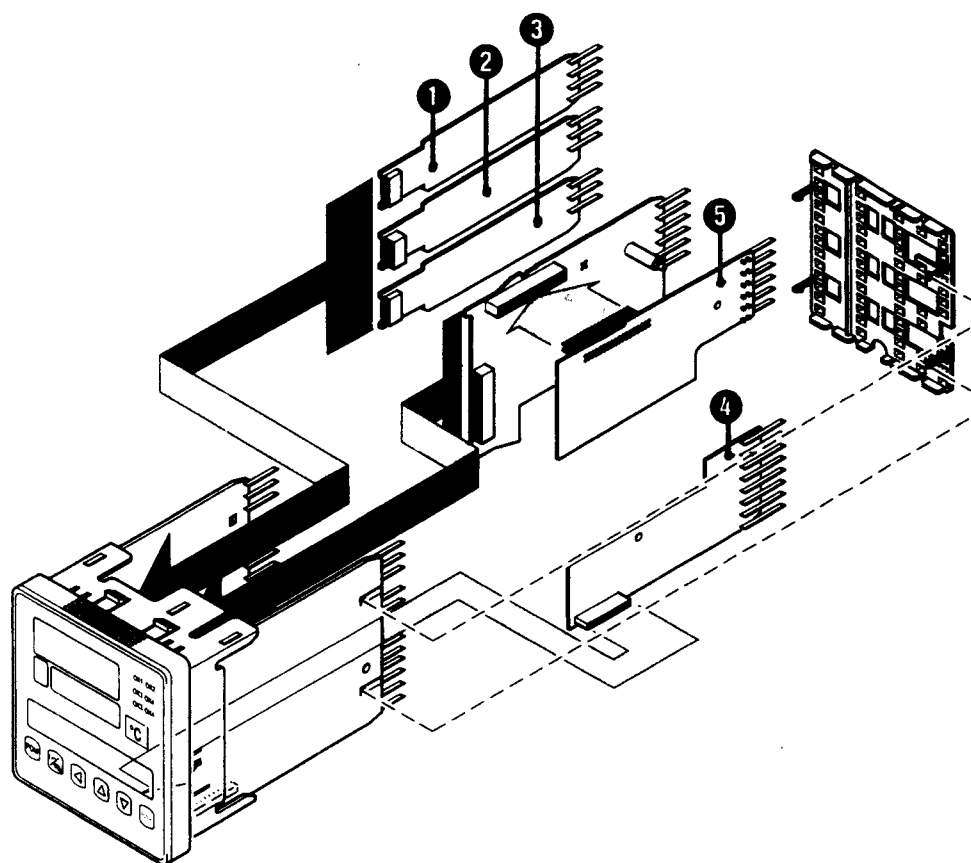

## List of cards

Item	Description	Code	Sales No.
❶	Output 1: relay	1	70/00308449
	solid state relay 1 A	2	70/00310737
	logic 0/24 V	3	70/00308450
	analogue output		
	0 — 20 mA	4	70/00308453
	4 — 20 mA	5	70/00308453
	-20 / 0 / +20 mA	6	70/00308453
	0 — 10 V	7	70/00308453
	2 — 10 V	8	70/00308453
-10 / 0 / +10 V	9	70/00308453	
❷	Output 3: relay	31	70/00308449
	solid state relay 1 A	32	70/00310737
	logic 0/24 V	33	70/00308450
	analogue output		
	0 — 20 mA	34	70/00308453
	4 — 20 mA	35	70/00308453
	-20 / 0 / +20 mA	36	70/00308453
	0 — 10 V	37	70/00308453
	2 — 10 V	38	70/00308453
	-10 / 0 / +10 V	39	70/00308453

## 18 RETROFITTING OF CARDS

Item	Description	Code	Sales No.
③	Output 4: relay	41	70/00308449
	solid state relay 1 A	42	70/00310737
	logic 0/24 V	43	70/00308450
	analogue output		
	0 — 20 mA	44	70/00308453
	4 — 20 mA	45	70/00308453
	-20 / 0 / +20 mA	46	70/00308453
	0 — 10 V	47	70/00308453
	2 — 10 V	48	70/00308453
-10 / 0 / +10 V	49	70/00308453	
④	Analogue inputs 3 + 4 (A/D converter II)	01	70/00308448
⑤	Interface RS422, isolated	52	70/00306273
	Interface RS485, isolated	53	70/00331016

# 19 APPENDIX

## 19.1 Technical data

### Profile controller

- 25 profile programs, each with two synchronised profiles
- up to 100 segments per profile
- up to 500 segments altogether
- 8 operating contacts

### Analogue inputs

#### Resistance thermometer in 3-wire circuit

Type	Range
Pt 100	-200 + 850 °C

Lead resistance:  
40 Ω max.  
Measurement current:  
150 µA

### Thermocouples

Type	Range
NiCrSi-NiSi N	-100 +1300 °C
Cu-Con T	-200 + 400 °C
Fe-Con J	-200 +1200 °C
Cu-Con U	-200 + 600 °C
Fe-Con L	-200 + 900 °C
NiCr-Ni K	-200 +1372 °C
Pt10Rh-Pt S	0 +1768 °C
Pt13Rh-Pt R	0 +1768 °C
Pt30Rh-Pt6Rh B	- 55 +1820 °C
NiCr-Con E	-200 + 915 °C

Lead resistance:  
300 Ω max.

### Standard signals

Signal	Internal resistance Ri Voltage drop ΔUe
0 — 50 mV	Ri = 1 MΩ min.
0 — 1 V	Ri = 100 kΩ min.
0 — 10 V	Ri = 100 kΩ min.
0 — 20 mA	ΔUe = 1 V max.
10 — 50 mV	Ri = 1 MΩ min.
0.2 — 1 V	Ri = 100 kΩ min.
2 — 10 V	Ri = 100 kΩ min.
4 — 20 mA	ΔUe = 1 V max.

Max. permitted input voltage: 12 V

### Resistance transmitter

100 Ω min., 10 kΩ max.  
Measurement current  
2 mA max.

### Current input for heater current indication

0 — 20 mA AC 50/60 Hz ±1 %  
for connection to a current transformer

### Logic inputs

Functions are normally activated by a floating contact (switching voltage 0/24 V to special order):

- start/abort self-optimisation
- auto/manual changeover
- setpoint changeover
- process value changeover
- parameter set switching
- inhibit parameter/configuration level
- text display
- all displays OFF
- inhibit profile program editor
- profile program start/stop
- profile program abort
- fast forward
- profile program selection

### Outputs

Four outputs are available. Output 2 is always a switching output, the others can be either switching or analogue outputs.

The following **output modules** are available:

#### Relay output

- changeover contact, 3 A at 230 V AC resistive load
- 10<sup>6</sup> operations at rated current
- contact protection circuit between common and n.o. (make) contact

#### Logic output

- 0/24 V, Ri = 1.2 kΩ

#### Solid state relay (triac)

- 1 A, 230 V

#### Analogue output

Signal	Load
0 — 10 V	500 Ω min.
2 — 10 V	
-10 / 0 / +10 V	500 Ω max.
0 — 20 mA	
4 — 20 mA	
-20 / 0 / +20 mA	

#### Supply for 2-wire transmitter

- 18 V 45 mA, isolated

# 19 APPENDIX

## Controller modes

### Single-setpoint controller

- O (break) function (heating)  
(relay de-energised above setpoint)
- S (make) function (cooling)  
(relay de-energised below setpoint)

### Double-setpoint controller

- switching (heating),  
switching (cooling)
- falling characteristic (heating),  
switching (cooling)
- switching (heating),  
rising characteristic (cooling)
- falling characteristic (heating),  
rising characteristic (cooling)

### Modulating controller

#### Proportional controller

- falling characteristic (indirect action) (heating)
- rising characteristic (direct action) (cooling)

#### Proportional controller with integral driver for motorised actuators

## Controller structures

### Single-setpoint, double-setpoint and proportional controllers

- P
- I
- PD
- PI
- PID

### Modulating controller

- PI
- PID

#### Proportional controller with integral driver for motorised actuators

- P
- I
- PD
- PI
- PID

## Interfaces

### RS422 or RS485 interface

Transfer rate: 187.5 kbaud max.  
Transfer protocol: Jbus / MODbus

### Setup interface

Connection via PC interface with TTL/RS232 converter; connector at top of housing (extra hardware Code)

## General data

### Displays:

one red 13 mm 4-digit 7-segment display  
one green 10 mm 4-digit 7-segment display  
one red 7 mm 1-digit 7-segment display  
one green 5 mm 16-digit 5x5 dot matrix display

Measurement accuracy	Ambient temperature error
when used with resistance thermometers	
0.05 % or better	0.025 % max. per 10 °C
when used with thermocouples within the working range	
0.25 % or better	0.05 % max. per 10 °C
when used with transducers with standard signal	
0.05 % or better	0.1 % max. per 10 °C
when used with resistance transmitters (after compensating the lead resistance)	
0.15 % or better	0.025 % max. per 10 °C

These values include linearisation tolerances.

## Signal circuit monitoring

Input	Probe break	Short-circuit
Thermocouples:	X	—
Resistance thermometers and transmitters:	X	X
0 — 50 mV	X	—
10 — 50 mV	X	X
0.2 — 1 V	X	X
2 — 10 V	X	X
4 — 20 mA	X	X

X = is recognized    — = is not recognized

The outputs move to a defined status.

### Resolution A/D converter

15 bit

### Resolution D/A converter

13 bit

### Sampling time

single-channel controller: 70 msec at 50 Hz  
75 msec at 60 Hz  
dual-channel controller: 110 msec at 50 Hz  
125 msec at 60 Hz

When a maths formula is being calculated the sampling time is increased in line with the complexity of the formula.

# 19 APPENDIX

## Data back-up

EEPROM

## Supply

93 — 263 V AC 48 — 63 Hz

20 — 53 V DC/AC 0/48 — 63 Hz

Operation with zener barriers is not permitted on 93 — 263 V AC.

## Power rating

20 VA max.

## Electrical connection

screw terminals up to 2.5 mm<sup>2</sup> cross-section and core termination sleeve

## Permitted ambient temperature range

0 to 50 °C

## Permitted storage temperature range

–40 to +70 °C

## Climatic conditions

relative humidity 75 % max. annual mean, no condensation

## Housing

flush panel mounting to DIN 43 700, conductive plastics, base material ABS, with plug-in controller chassis  
bezel 96 x 96 mm  
depth behind panel 150 mm

## Protection

to EN 60 529

front IP 65

rear IP 20

## Electrical safety

to EN 61 010

– overvoltage category II

– protection Class I (rear)

– protection Class II (front through panel mounting)

## Electromagnetic compatibility

to NAMUR recommendation NE 21,

EN 50 081-1, EN 50 082-2

## Operating position

unrestricted

## Weight

850 g

## Limit comparators

The controller incorporates eight limit comparators which can be linked up internally and switched to the controller outputs.

## Switching differential

X<sub>Sd</sub> adjustable within the range 0 — 9999 digit

## Limit setting

AL adjustable within the range –1999 to +9999 digit

## Maths and logics module

### Maths module:

Linking the analogue inputs and logical signals by a mathematical formula.

### Logics module:

Linking the logic inputs, limit comparator outputs and operating contacts.

Difference, ratio and humidity controllers are set up through standard formulae implemented in the maths and logics module.

## Isolation of inputs

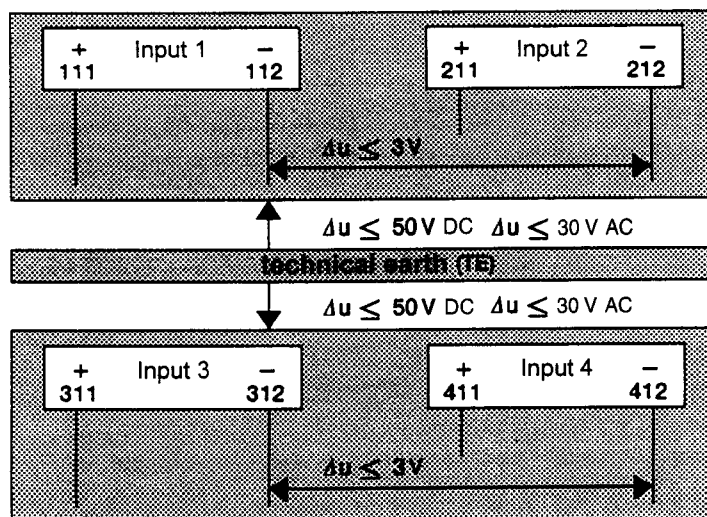

# 19 APPENDIX

## 19.2 Limit comparator functions

### Function Ik1

Window function: the relay is energised when the process value is within a window about the setpoint ( $w$ ).

Example:  $w = 200\text{ }^{\circ}\text{C}$ ,  $AL = 20$ ,  $X_{Sd} = 10$

Process value rising:  
relay switches on at  $185\text{ }^{\circ}\text{C}$  and off at  $225\text{ }^{\circ}\text{C}$ .

Process value falling:  
relay switches on at  $215\text{ }^{\circ}\text{C}$  and off at  $175\text{ }^{\circ}\text{C}$ .

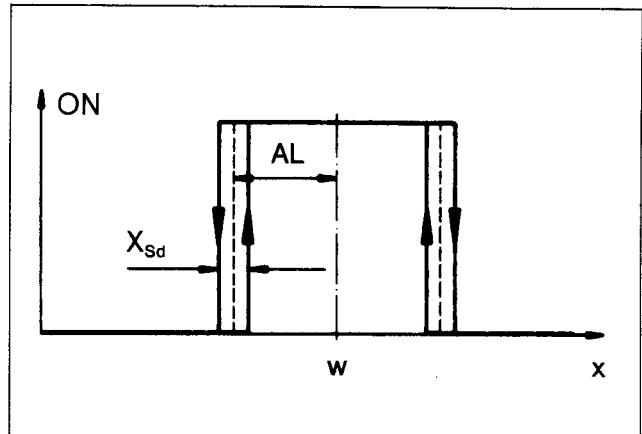

### Function Ik2

as Ik1 but relay action reversed

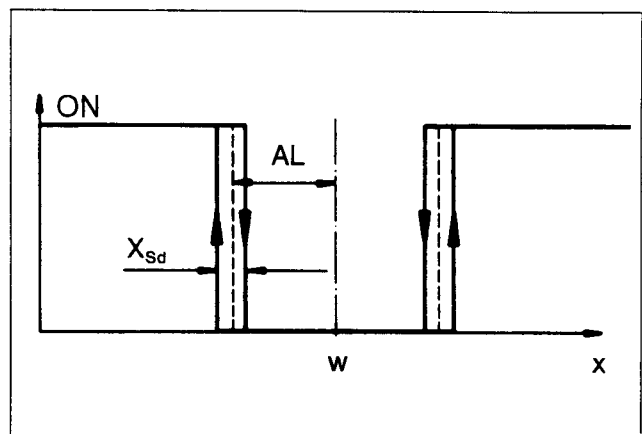

### Function Ik3

low alarm

Function: the relay is de-energised when the process value falls below (setpoint - limit value).

Example:  $w = 200\text{ }^{\circ}\text{C}$ ,  $AL = 20$ ,  $X_{Sd} = 10$

Process value rising:  
relay switches on at  $185\text{ }^{\circ}\text{C}$ .

Process value falling:  
relay switches off at  $175\text{ }^{\circ}\text{C}$ .

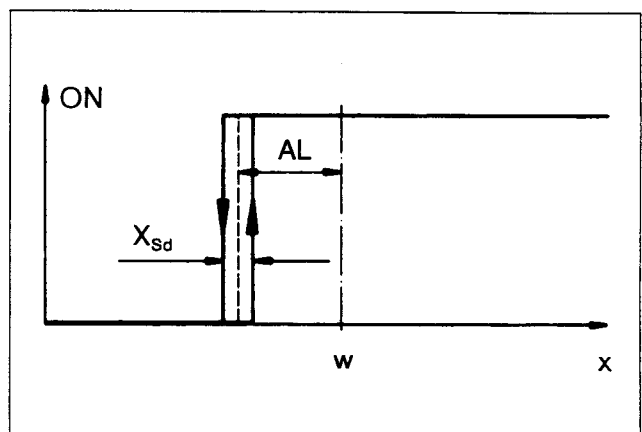

### Function Ik4

as Ik3 but relay action reversed

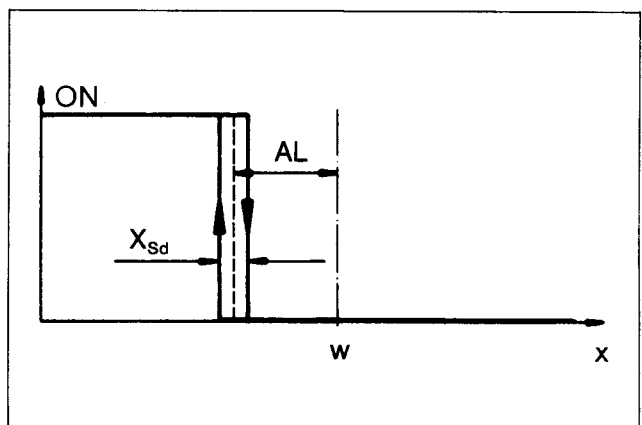

$w$  = setpoint  
 $x$  = process value  
 $X_{Sd}$  = differential  
 $AL$  = limit

# 19 APPENDIX

## Function Ik5

high alarm

Function: the relay is de-energised when the process value rises above (setpoint + limit value).

Example:  $w = 200\text{ }^{\circ}\text{C}$ ,  $AL = 20$ ,  $X_{Sd} = 10$

Process value rising:  
relay switches off at  $225\text{ }^{\circ}\text{C}$ .

Process value falling:  
relay switches on at  $215\text{ }^{\circ}\text{C}$ .

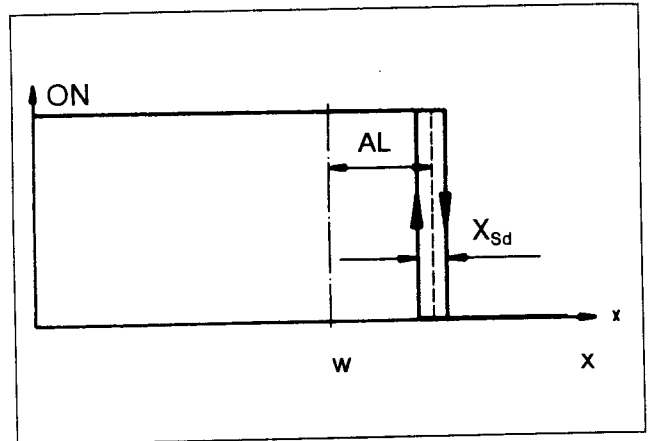

## Function Ik6

as Ik5 but relay action reversed

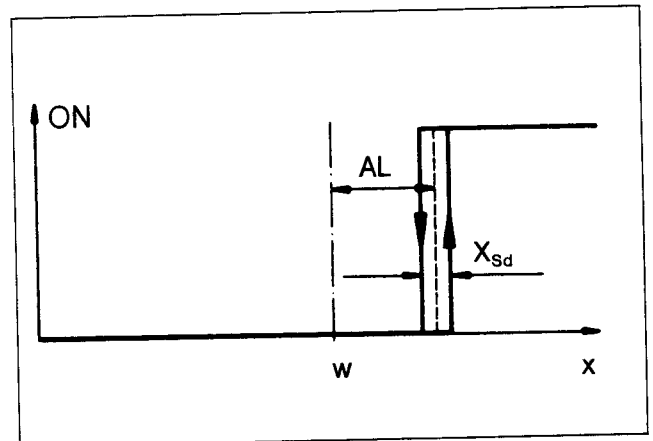

## Function Ik7

Switching point is independent of the controller setpoint and is determined only by AL.

Function: the relay is energised when the process value is above the limit AL.

Example:  $AL = 150$ ,  $X_{Sd} = 10$

Process value rising:  
relay switches on at  $155\text{ }^{\circ}\text{C}$ .

Process value falling:  
relay switches off at  $145\text{ }^{\circ}\text{C}$ .

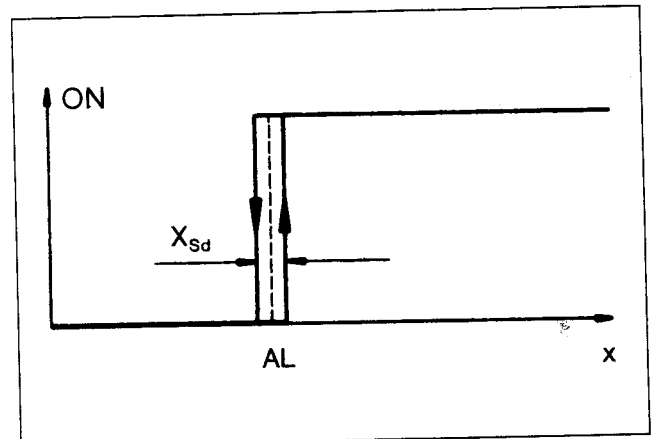

## Function Ik8

as Ik7 but relay action reversed

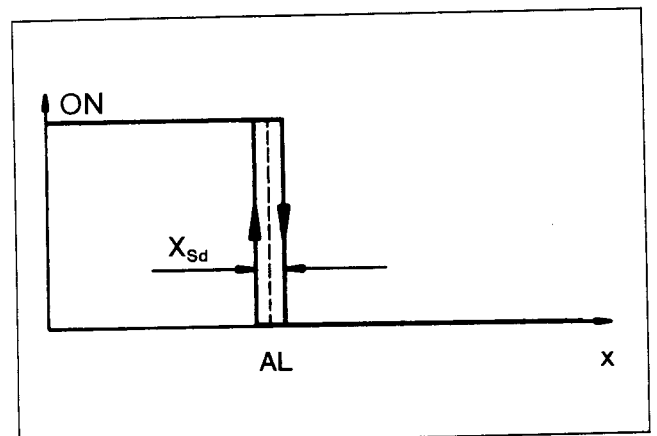

# 19 APPENDIX

## 19.3 Alarm messages and indication priorities in the standard display

### Alarm messages in plain language (matrix display)

Priority	Display	Notes
high	(No display)	Logic input "all displays off" is configured and active
	PROBE BREAK IN1	Probe break or short-circuit
	PROBE BREAK IN2	
	PROBE BREAK IN3	
	PROBE BREAK IN4	
	OVERRANGE IN1	Overrange
	OVERRANGE IN2	
	OVERRANGE IN3	
	OVERRANGE IN4	
	UNDERRANGE IN1	Underrange
	UNDERRANGE IN2	
	UNDERRANGE IN3	
	UNDERRANGE IN4	
	OVERRANGE MATH1	Overrange maths module (calculation result > range end)
	OVERRANGE MATH2	
	UNDERRANGE MATH1	Underrange maths module (calculation result < range start)
	UNDERRANGE MATH2	
	MATH 1 ERROR	Maths error (violation of mathematical rules, illegal values)
	MATH 2 ERROR	
	LOGIC 1 ERROR	Logics error (violation of mathematical rules)
	LOGIC 2 ERROR	
	LOOP ERROR C1	Load short-circuit or interruption has been recognised
	LOOP ERROR C2	
	ADC ERROR	Error A/D converter
	RELAY MODULE ERR	Error relay module
	SET CLOCK	Real time clock must be set (acknowledgement) Data back-up should be checked
	RESTART ERROR	Restart data are corrupted (acknowledgement)
	STORE FULL	Program store is full (acknowledgement)
	PGM NOT AVAIL.	Program is not available (acknowledgement)
	(TEXT)	Text display (logic input 1)
	(TEXT)	Text display (logic input 2)
	(TEXT)	Text display (logic input 3)
	(TEXT)	Text display (logic input 4)
	(TEXT)	Text display (logic input 5)
(TEXT)	Text display (limit comparator 1)	
(TEXT)	Text display (limit comparator 2)	
(TEXT)	Text display (limit comparator 3)	
(TEXT)	Text display (limit comparator 4)	

# 19 APPENDIX

Priority	Display	Notes
	(TEXT)	Text display (limit comparator 5)
	(TEXT)	Text display (limit comparator 6)
	(TEXT)	Text display (limit comparator 7)
	(TEXT)	Text display (limit comparator 8)
	(TEXT)	Text display (logic input 1)
	(TEXT)	Text display (logic input 2)
	(TEXT)	Text display (operating contact 1)
	(TEXT)	Text display (operating contact 2)
	(TEXT)	Text display (operating contact 3)
	(TEXT)	Text display (operating contact 4)
	(TEXT)	Text display (operating contact 5)
	(TEXT)	Text display (operating contact 6)
	(TEXT)	Text display (operating contact 7)
	(TEXT)	Text display (operating contact 8)
	TUNE ACTIVE	Self-optimisation has been activated
LOW	(Indication as configured)	—

AIN = analogue input; M = maths







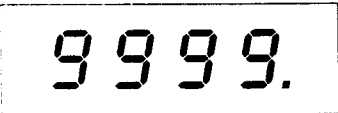

## Alarm messages with acknowledgement

Alarm messages with acknowledgement are identified by the symbol  on the matrix display.

On pressing  the message disappears.

## Alarm messages in numerical display

Display	Note
 	<ul style="list-style-type: none"> <li>– Overrange</li> <li>– Probe break (segment display is flashing)</li> </ul>
 	Underrange (segment display is flashing)
 	No measurement

# 19 APPENDIX

## 19.4 Character set for matrix display

0	32	64	@	96	128	Ç	160	á	192	224	α		
1	33	!	65	A	97	a	129	ü	161	í	193	β	
2	34	“	66	B	98	b	130	é	162	ó	194	Γ	
3	35	#	67	C	99	c	131	â	163	ú	195	227	Π
4	36	\$	68	D	100	d	132	ä	164	ñ	196	228	Σ
5	37	%	69	E	101	e	133	à	165	Ñ	197	229	σ
6	38	&	70	F	102	f	134	å	166		198	230	μ
7	39	‘	71	G	103	g	135	ç	167		199	231	γ
8	40	(	72	H	104	h	136	ê	168	¿	200	232	φ
9	41	)	73	I	105	i	137	ë	169		201	233	θ
10	42	*	74	J	106	j	138	è	170		202	234	Ω
11	43	+	75	K	107	k	139	ï	171		203	235	δ
12	44	.	76	L	108	l	140	î	172		204	236	∞
13	45	-	77	M	109	m	141	ì	173		205	237	∅
14	46	.	78	N	110	n	142	Ä	174		206	238	ε
15	47	/	79	O	111	o	143	Å	175		207	239	∩
16	48	0	80	P	112	p	144	É	176		208	240	
17	49	1	81	Q	113	q	145	æ	177		209	241	
18	50	2	82	R	114	r	146	Æ	178		210	242	
19	51	3	83	S	115	s	147	ô	179		211	243	
20	52	4	84	T	116	t	148	ö	180		212	244	
21	53	5	85	U	117	u	149	ò	181		213	245	
22	54	6	86	V	118	v	150	û	182		214	246	
23	55	7	87	W	119	w	151	ù	183		215	247	
24	56	8	88	X	120	x	152	ÿ	184		216	248	°
25	57	9	89	Y	121	y	153	Ö	185		217	249	·
26	58	:	90	Z	122	z	154	Ü	186		218	250	
27	59	:	91	[	123	{	155	ø	187		219	251	
28	60	<	92	\	124		156	£	188		220	252	
29	61	=	93	]	125	}	157	¥	189		221	253	
30	62	>	94	^	126	~	158		190		222	254	
31	63	?	95	--	127		159		191		223	255	

200 — 210 reserved for bargraph display

# 19 APPENDIX

## 19.5 Restart after supply failure

### Status after supply is restored

Status before supply failure	(1)	(2)	(3)	(4)	(5)	(6)	(7)	(8)
<b>Profile stop</b>	(1)	(2)	(1)	(1)	(1)	(1)	(1)	(1)
<b>Continue</b>								
Process value within range	(1)	(2)	(3)	(4)	(5)	(6)	(7)	(8)
Process value overrange / underrange	(1)	(2)	(7)	(4)	(5)	(6)	(7)	(8)
<b>Stopped</b>	(1)	(2)	(7)	(7)	(7)	(6)	(7)	(8)
<b>Continue X %</b>								
$[\text{ABS}(X_{\text{old}} - X_{\text{new}}) / X_{\text{old}}] \cdot 100 \leq X \%$	(1)	(2)	(3)	(4)	(5)	(6)	(7)	(8)
$[\text{ABS}(X_{\text{old}} - X_{\text{new}}) / X_{\text{old}}] \cdot 100 > X \%$	(1)	(2)	(7)	(7)	(7)	(6)	(7)	(8)
Process value overrange / underrange	(1)	(2)	(7)	(7)	(7)	(6)	(7)	(8)
<b>Continue at process value</b>								
Process value within range	(1)	(2)	(3)	(3)	(3)	(6)	(7)	(8)
Process value overrange / underrange	(1)	(2)	(7)	(7)	(7)	(6)	(7)	(8)

- $X_{\text{po}}$  = process value deviation  
 $X_{\text{old}}$  = process value before supply failure  
 $X_{\text{new}}$  = process value after supply is restored

- |                               |                                |
|-------------------------------|--------------------------------|
| (1) Basic status              | (5) Auto-manual operating mode |
| (2) Delay period              | (6) Profile end                |
| (3) Continue at process value | (7) Stop                       |
| (4) Auto operating mode       | (8) Manual operating mode      |

#### Profile stop

The profile program run is held.

#### Continue

The profile program continues at the point where it was aborted at the instant of supply failure.

#### Stopped

The profile program can be continued by pressing 

#### Continue X %

The profile program continues at the point where it was aborted at the instant of supply failure, provided the deviation between the process value before supply failure ( $X_{\text{old}}$ ) and the process value after supply restoration ( $X_{\text{new}}$ ) does not exceed a programmable percentage (process value deviation).

# 19 APPENDIX

## Continue at process value

On a supply failure the sign of the gradient (falling or rising slope) at the instant of supply failure is stored. After the supply has been restored the profile program is tested from the beginning for agreement between process value and setpoint. The program continues from the point where there is agreement between process value and setpoint and the sign of the gradient corresponds to the stored sign.

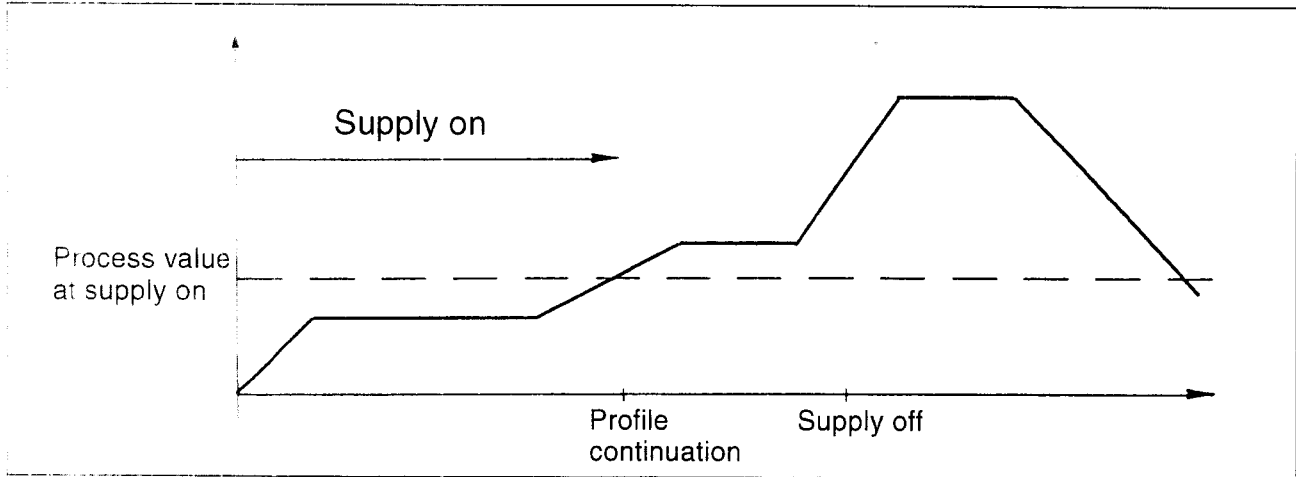

## Sales Offices and Service Stations – Germany

### M.K. JUCHHEIM GmbH & Co

36035 Fulda, Germany  
Phone (06 61) 60 03-0  
Fax (06 61) 60 03-5 00  
email JUMO\_de@e-mail.com

### Berlin

Kai-Lwe Krauspenhaar  
Bauteil 2, Zimmer 323  
Arkonastraße 45-49  
13189 Berlin  
Phone (0 30) 47 30 47 38  
Fax (0 30) 47 30 47 48

### Cologne

M.K. Juchheim GmbH & Co  
Niederlassung Köln  
Am Vogelsang 17a  
50374 Ertstadt-Liblar, Germany  
Phone (0 22 35) 9 23 23-0  
Fax (0 22 35) 9 23 23-23

### Darmstadt

M.K. Juchheim GmbH & Co  
Niederlassung Darmstadt  
Weiterstädter Straße 135  
64291 Darmstadt-Arheilgen, Germany  
Phone (0 61 51) 35 08-0  
Fax (0 61 51) 35 08-81

### Erfurt

M.K. Juchheim GmbH & Co  
Außenbüro Erfurt  
Friedrich-Engels-Straße 12  
99334 Ichtershausen, Germany  
Phone (0 36 28) 7 57 63  
Fax (0 36 28) 7 57 31

### Essen

M.K. Juchheim GmbH & Co  
Niederlassung Essen  
Alte Bottroper Straße 45  
45356 Essen, Germany  
Phone (02 01) 8 66 27-0  
Fax (02 01) 8 66 27-50

### Giessen

M.K. Juchheim GmbH & Co  
Niederlassung Gießen  
An der Amtmannsmühle 1  
Postfach 11 08  
35444 Biebertal, Germany  
Phone (0 64 09) 81 00-0  
Fax (0 64 09) 81 00-49

### Hamburg

M.K. Juchheim GmbH & Co  
Außenbüro Hamburg  
Horstweg 20  
22391 Hamburg, Germany  
Phone (0 40) 60 04 63-0  
Fax (0 40) 60 04 63-20

### Hannover

M.K. Juchheim GmbH & Co  
Niederlassung Hannover  
Gehrenbreite 2  
31542 Bad Nenndorf, Germany  
Phone (0 57 23) 94 32-0  
Fax (0 57 23) 94 32-50

### Leipzig

M.K. Juchheim GmbH & Co  
Außenbüro Leipzig  
Demmeringstraße 63  
04177 Leipzig, Germany  
Phone (03 41) 4 90 08-10  
Fax (03 41) 4 90 08-32

### Magdeburg

M.K. Juchheim GmbH & Co  
Außenbüro Magdeburg  
Parzellenweg 1a  
39130 Magdeburg, Germany  
Phone (03 91) 7 22 06 19  
Fax (03 91) 7 22 16 19

### Munich

M.K. Juchheim GmbH & Co  
Außenbüro München  
Himmelreichweg 23  
85221 Dachau, Germany  
Phone (0 81 31) 3 76 61-6  
Fax (0 81 31) 3 76 61-75

### Nuremberg

M.K. Juchheim GmbH & Co  
Außenbüro Nürnberg  
Schäferweg 3  
91233 Neunkirchen am Sand, Germany  
Phone (0 91 23) 96 94-5  
Fax (0 91 23) 96 94-60

### Stuttgart

M.K. Juchheim GmbH & Co  
Niederlassung Stuttgart  
Einsteinstraße 42  
73230 Kirchheim unter Teck, Germany  
Phone (0 70 21) 9 50 91-0  
Fax (0 70 21) 9 50 91-50

## Europe and USA

### Austria

JUMO Meß- und Regelgeräte Ges.m.b.H  
Pfarrgasse 48  
A-1232 Wien  
Phone (02 22) 6 10 61-0  
Fax (02 22) 6 10 61-59  
Telex 13-30 76

### Belgium and Luxembourg

JUMO AUTOMATION  
S.P.R.L. / P.G.M.B.H. / B.V.B.A  
Industriestraße 18  
B-4700 Eupen  
Phone (0 87) 59 53 00  
Fax (0 87) 74 02 03

### Denmark

JUMO Måle- og Reguleringssteknik A/S  
Fabriksvænget 16,  
Postboks 80  
DK-4130 Viby Sj  
Phone (0) 46 19 46 66  
Fax (0) 46 19 43 63

### France

JUMO Regulation S.A.  
Actipôle Borny  
7, Rue des Drapiers  
B.P. 45200  
F-57075 Metz - Cedex 3  
Phone 03 87 37 53 00  
Fax 03 87 74 20 92  
Telex 930 464

### Italy

JUMO Italia s.r.l.  
Piazza Esquilino 5  
I-20148 Milano  
Phone (02) 40 09 21 41  
Fax (02) 4 07 81 05

### Netherlands

JUMO Meet- en Regeltechniek B.V.  
Postbus 115  
NL-1380 AC Weesp  
Phone (02 94) 49 14 91  
Fax (02 94) 41 95 77

### Poland

Przedstawicielstwo Firmy  
M.K. Juchheim GmbH & Co w Polsce  
Pl. Powstańców Śląskich 5 pok. 43 A  
PL-53-329 Wrocław  
Phone (0 71) 3 39 84 60  
Fax (0 71) 3 38 12 82

### Poland

DYNAMIKA II sp.t.o.o.  
ul. Chorzowska 44b  
PL-44-100 Gliwice  
Phone (0 32) 31 82 93  
Fax (0 32) 31 33 50

### Russia

JUMO GmbH  
P.O. Box 205  
RF-121 019 Moskau  
Phone (0 95)-2 35 86 65  
Fax (0 95)-2 35 86 65

### Sweden

JUMO Mät- och Reglerteknik AB  
Karbingatan 32  
Box 22073  
S-25022 Helsingborg  
Phone (0 42) 12 36 60  
Fax (0 42) 20 16 15  
Telex 72 058 jutex S

### Switzerland

JUMO Mess- & Regeltechnik AG  
Seestrasse 67  
CH-8712 Stäfa  
Phone (01) 928 21 41  
Fax (01) 926 67 65

### Spain

JUMO Sercon S.A.  
Taiguigra Garriga, 44  
E-08014 Barcelona  
Phone (93) 410 9492  
Fax (93) 419 6431

### United Kingdom

JUMO Instrument Co. Ltd.  
Temple Bank, Riverway  
GB-Harlow, Essex CM 20 2TT  
Phone (0 12 79) 63 55 33  
Fax (0 12 79) 63 52 62

### USA

JUMO PROCESS CONTROL INC.  
735 Fox Chase, Coatesville PA 19320  
Phone 610-380-8002, 800-554-JUMO  
Fax 610-380-8009

### Representatives in:

Argentina, Baltic States, Bangladesh, Brazil, Bulgaria, Canada, Chile, P.R. of China, Croatia, Czech Republic, Egypt, Finland, Greece, Guatemala, Hungary, India, Indonesia, Iran, Irish Republic, Israel, Korea, Kuwait, Malaysia, Mexico, Norway, Pakistan, Philippines, Poland, Portugal, Romania, Singapore, Slovak Republic, Slovenia, Taiwan, Turkey, Ukraine, Venezuela



MEASUREMENT AND CONTROL

**M. K. JUCHHEIM GmbH & Co**

36035 Fulda

Germany

Telephone (int. +49) 661 6003 – 0

Fax (int. +49) 661 6003 – 607

Telex 49701 juf d

email [JUMO\\_de@e-mail.com](mailto:JUMO_de@e-mail.com)