

JUMO dTRON 04.1

JUMO dTRON 08.1

Compact microprocessor
controller

B 70.3030
Operating Manual

11.99/00329816



Please read this Manual carefully before starting up the instrument. Keep the Manual in a place which is at all times accessible to all users. Please assist us to improve this Manual where necessary. Your suggestions will be most welcome.

Phone:

Germany (0661) 6003-727

abroad (int. +49) 661 6003-0

Fax:

Germany (0661) 6003-508

abroad (int. +49) 661 6003-607



All necessary settings and, where appropriate, alterations inside the instrument are described in this Operating Manual. If any difficulties should arise during start-up, you are asked not to carry out any manipulations on the unit which are not permitted. You could endanger your rights under the instrument warranty! Please contact the nearest office or the main factory.



When returning chassis, assemblies or components, the rules of EN 100 015 "Protection of electrostatically endangered components" have to be observed. Use only the appropriate **ESD** packaging material for transport.

Please note that we can not be held liable for any damage caused by ESD (electrostatic discharges)

Contents

1	Introduction	5
1.1	Description	5
1.2	Block diagram	6
1.3	Typographical conventions	7
1.3.3	Presentation	8
2	Identifying the instrument version	9
3	Installation	11
3.1	Location and climatic conditions	11
3.2	Dimensions	11
3.2.1	Type 703030	11
3.2.2	Type 703031	12
3.2.3	Edge-to-edge mounting	12
3.3	Fitting in position	13
3.4	Cleaning the front panel	13
3.5	Removing the controller chassis	13
4	Electrical connection	14
4.1	Notes on installation	14
4.2	Connection diagram	15
5	Preparation	17
5.1	Display and keys	17
5.2	Operating mode and states	17
5.3	Principle of operation	18
5.3.1	Levels	18
5.3.2	Value input	19
5.3.3	Programming the controller	19
6	Operation	20
6.1	Alter setpoints (SP1, SP2)	20
6.2	Display controller output (y)	20
6.3	Display measured value on analogue input 2 (InP.2)	20
6.4	Activate manual operation	21
6.5	Start self-optimisation	21
6.6	Indicate software version and unit	21
7	Parameters	22

Contents

8	Configuration	24
8.1	C111 - Inputs	24
8.2	C112 - Logic inputs, ramp function, overrange, unit/supply	25
8.3	C113 - Interface	26
8.4	C211 - Limit comparators	27
8.5	C212 - Controller type, manual operation inhibit, fuzzy function, output 3 ¹	28
8.6	C213- Functions of the outputs1	29
8.7	SCL - Standard signal scaling	30
8.8	SCH - Standard signal scaling	30
8.9	SPL - Setpoint limit	30
8.10	SPH - Setpoint limit	30
8.11	OFFS - Process value correction	30
9	Optimisation	31
9.1	Optimisation	31
9.1.1	Self-optimisation	31
9.1.2	Fuzzy logic	31
9.2	Checking the optimisation	32
10	Logic inputs	33
11	Ramp functions	34
11.1	Ramp function	34
11.2	Start-up ramp for hot-channel method	35
12	Heater current indication/monitoring	37
12.1	Heater current indication	37
12.2	Heater current monitoring	37
13	Interface	38
14	Limit comparator functions	39
15	Alarm messages	41
16	Setpoint priorities	42
17	Technical data	43

Fold-out: Programming the controller

1 Introduction

1.1 Description

The compact microprocessor controllers Type 703030 and Type 703031, with the bezel sizes 96mm x 96mm and 48mm x 96mm resp. and with a plug-in controller chassis, are particularly suitable for temperature-controlled apparatus, laboratory equipment, plastics machinery, mechanical equipment etc. The controllers incorporate two 4-digit 7-segment displays for process value (red) and setpoint (green). During programming the displays serve for comments on the inputs.

The controllers can be programmed as a single or double setpoint controller, modulating or proportional controller with the usual controller structures. The five outputs can be freely configured. They also have two limit comparators which can be assigned to the input signals. There is a choice of eight different limit comparator functions. A ramp function with adjustable gradient, a start-up ramp for the hot-channel method, as well as self-optimisation are available as standard. An interface (RS422/RS485), available as an option, serves for integration into a data network. All connections are made through faston tags 4.8mm x 0.8mm to DIN 46 244/A.

1 Introduction

1.2 Block diagram

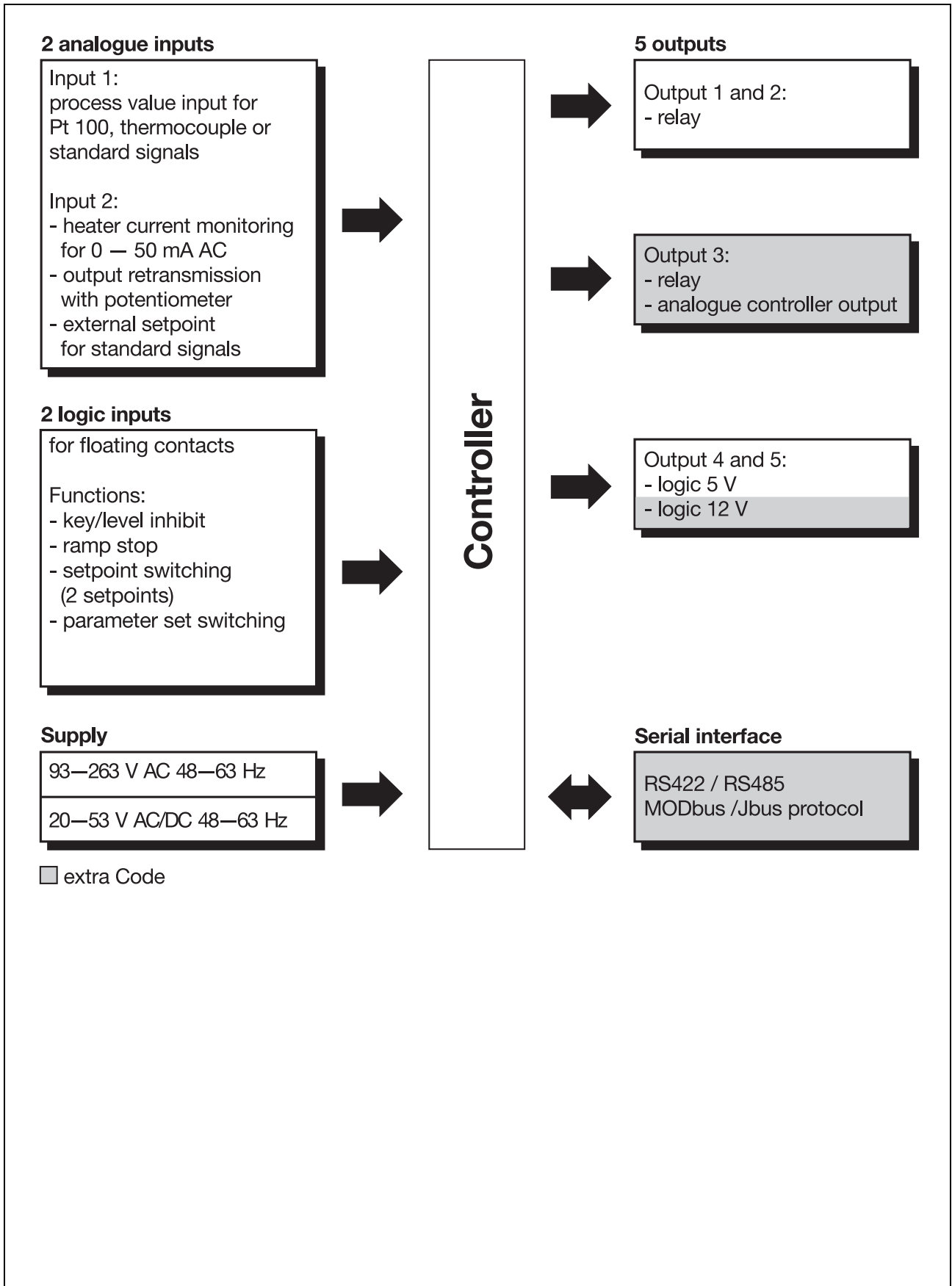

1 Introduction

1.3 Typographical conventions

1.3.1 Warnings

The signs for **Danger** and **Warning** are used in this Manual under the following conditions:



Danger

This symbol is used when there may be **danger to personnel** if the instruction is disregarded or not followed accurately.



Warning

This symbol is used when there may be **damage to equipment or data** if the instruction is disregarded or not followed accurately.



Warning

This symbol is used when precautions have to be observed in handling components liable to be damaged by electrostatic discharges.

1.3.2 Note signs



Note

This symbol is used if your **special attention** is drawn to a remark.



Reference

This symbol refers to **additional information** in other handbooks, chapters or sections.

abc¹

Footnote

Footnotes are **notes** which refer to certain points in the text.

Footnotes consist of 2 parts:

Markings in the text and in the footnote text.

The markings in the text are arranged as continuous raised numbers.

The footnote text (in smaller typeface) is placed at the bottom of the page and starts with a number and a full stop.

*** Action**

This symbol indicates that an **action is being described**.

The individual steps are indicated by this asterisk, e.g.

* Press  key

* Press  key

1 Introduction

1.3.3 Presentation

 PGM

Keys Keys are shown in a frame. Both symbols and text are possible. Where a key has a multiple function, the text shown corresponds to the function which is currently active.

 + 

Key combinations Keys shown together with a plus sign indicate that first  has to be pressed and held down and then a further key.



Item This is followed by explanations of diagrams and concepts.

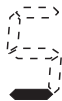

Digit Flashing digit on a 7-segment display.

2 Identifying the instrument version

The label is affixed to the instrument. The type designation contains all the factory settings, such as controller function, signal inputs and extra Codes.

The Codes ⑦ are shown in sequence and separated by a comma.

The supply must agree with the voltage shown on the label.

Type designation I

① ② ③ ④ ⑤ ⑥ ⑦
703030/ [..] - [...] - [...] - [..] - [...] - [..] / [...]
703031/ [..] - [...] - [...] - [..] - [...] - [..] / [...]

Delivery package:

- controller
- 2 mounting brackets
- seal
- Operating Manual B 70.3030

① Controller function	Code
Single-setpoint controller, O function (relay de-energised above setpoint)	10
Single-setpoint controller, S function (relay de-energised below setpoint)	11
Double-setpoint controller (heating/cooling)	3 .
switching/switching	. 0
analogue/switching	. 1
switching/analogue	. 2
Modulating controller	40
Proportional controller	5 .
falling characteristic (reverse acting)	. 0
rising characteristic (direct acting)	. 1

② Input 1	Code
Pt 100	001
Fe-Con J	040
Cu-Con U	041
Fe-Con L	042
NiCr-Ni K	043
Pt10Rh-Pt S	044
Pt13Rh-Pt R	045
Pt30Rh-Pt6Rh B	046
NiCrSi-NiSi N	048
Linearised transducers	
0–20 mA	052
4–20 mA	053
0–10 V	063
2–10 V	070

2 Identifying the instrument version

③ Input 2	Code
no function	000
Heater current indication 0—50 mA AC	090
Stroke retransmission potentiometer	101
External setpoint	11 .
0—20 mA	.. 1
4—20 mA	.. 2
0—10 V	.. 7
2—10 V	.. 8

④ Functions of logic inputs		
Logic input 1	Logic input 2	Code
no function	no function	00
Key inhibit	Parameter set switching	01
Level inhibit	Parameter set switching	02
Ramp stop	Parameter set switching	03
Setpoint selection	Parameter set switching	04
Key inhibit	Setpoint selection	05
Level inhibit	Setpoint selection	06
Ramp stop	Setpoint selection	07
Key inhibit	Ramp stop	08
Level inhibit	Ramp stop	09

⑤ Output 3	Code
not used	000
Relay	101
Analogue output	
0—20 mA	001
4—20 mA	005
0—10 V	065
2—10 V	070

⑦ Extra Codes (can be combined)	Code
no extra Code	000
Interface RS422/RS485	054
Logic outputs 4 and 5 with 0/12 V output signal	015
UL approval	061

⑥ Supply	Code
93—263 V AC 48—63 Hz	01
20—53 V DC/AC 48—63 Hz	22

Accessory
Current transformer (ratio 1:1000) size: 38 mm x 20 mm x 38 mm cable entry: 13 mm dia. Sales No. 70/00055040

3 Installation

3.1 Location and climatic conditions

The instrument location should as far as possible be free from shock and vibration. Stray electromagnetic fields, e.g. from motors, transformers etc., should be avoided. The ambient temperature at the location may be between 0 and +50 °C at a relative humidity not exceeding 75 %.

mm	inch
0.8	0.031
4.8	0.19
10.5	0.41
15.5	0.61
30.5	1.20
33.2	1.30
33.3	1.31
39.5	1.56
43.5	1.71
44 ^{+0.5}	1.73 ^{+0.02}
48	1.89
73	2.87
79.3	3.12
82	3.23
86.4	3.40
90.3	3.56
91.5	3.60
91.6	3.61
92 ^{+0.5}	3.62 ^{+0.02}
96	3.78
105.8	4.17

3.2 Dimensions

3.2.1 Type 703030

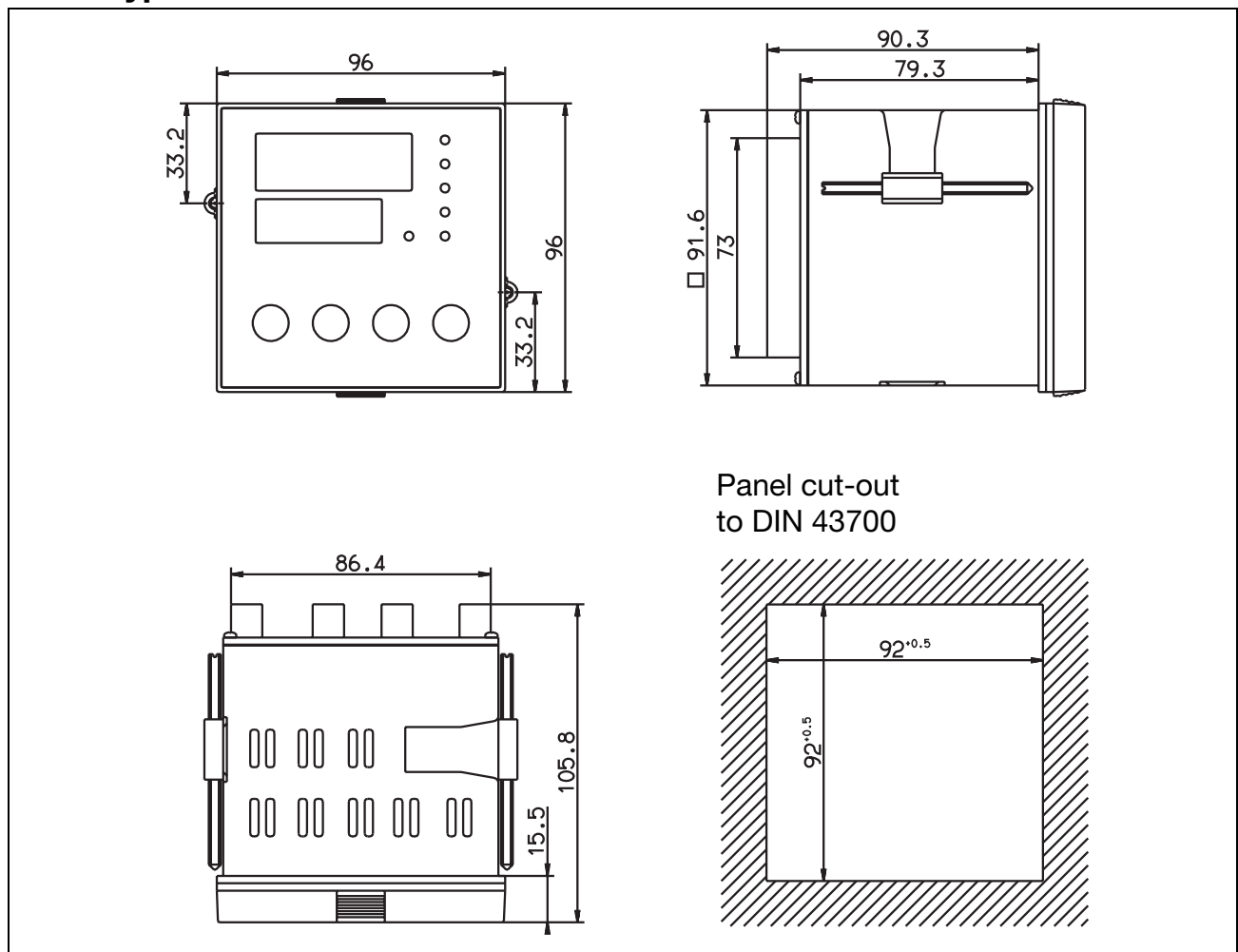

3 Installation

3.2.2 Type 703031

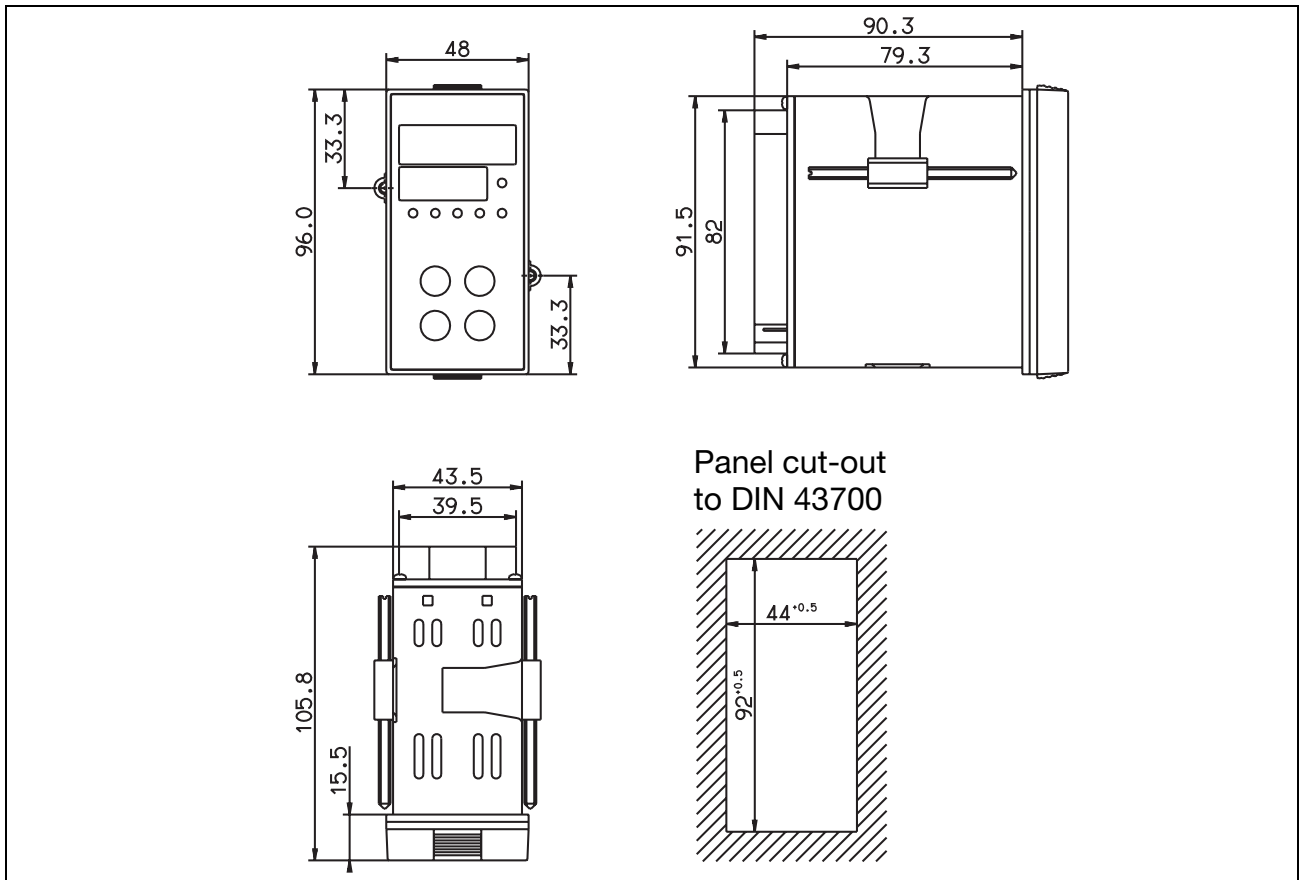

3.2.3 Edge-to-edge mounting

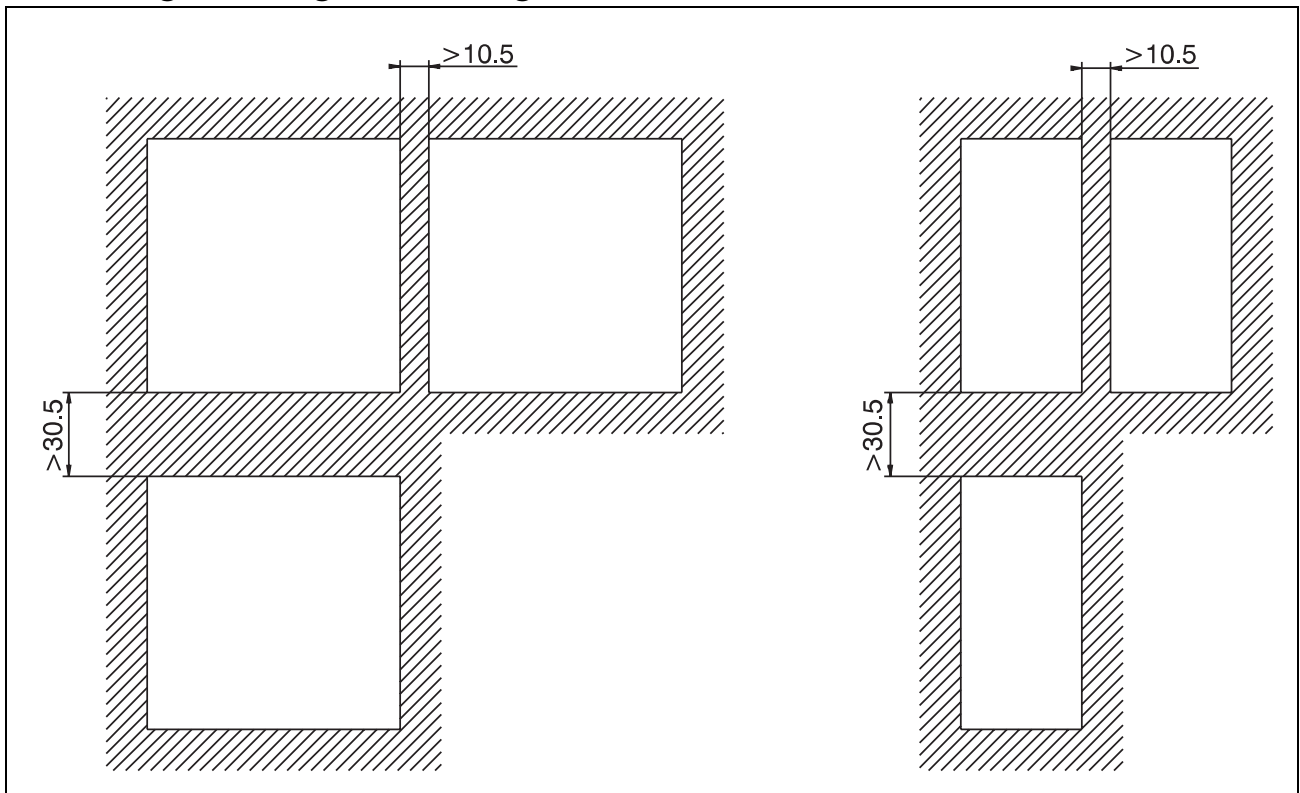

3 Installation

3.3 Fitting in position

- * Place the seal supplied onto the housing of the instrument.
- * Insert the controller from the front into the panel cut-out.
- * From the back of the panel slide the mounting brackets into the guides at the sides. The flat bracket faces must lie against the housing.
- * Place the brackets against the rear of the housing and tighten them evenly with a screwdriver.

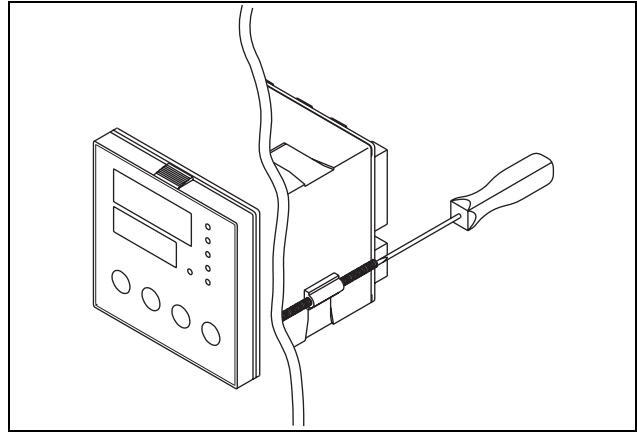

3.4 Cleaning the front panel

The front panel can be cleaned with the usual wash and rinse agents and detergents. It has a limited degree of resistance to organic solvents (e.g. petrol, benzene, P1, xylene and similar). Do not use any high-pressure cleaners.

3.5 Removing the controller chassis

The controller chassis can be removed from the housing for servicing.

- * Press together the knurled areas top and bottom on the front panel and pull out the controller chassis.

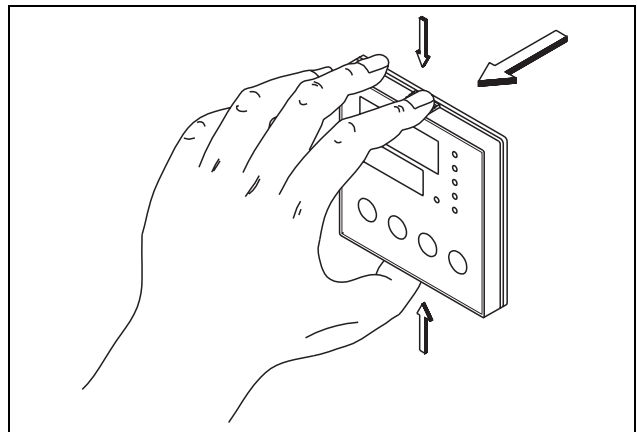

4 Electrical connection

4.1 Notes on installation

- The choice of cable, the installation and the electrical connection must conform to the requirements of VDE 0100 “Regulations on the installation of Power Circuits with nominal voltages below 1000V” or the appropriate local regulations.
 - The electrical connection must only be carried out by properly qualified personnel.
 - If contact with live parts is possible when working on the instrument, it has to be isolated on both poles from the supply.
 - A current limiting resistor interrupts the supply circuit in case of a short-circuit. An additional external fuse of the supply should not be rated above 1 A (slow). The load circuit must be fused for the maximum relay current in order to prevent welding of the output relay contacts in case of an external short-circuit.
 - Electromagnetic compatibility conforms to the standards and regulations listed under Technical Data.
-  Chapter 17
- Run input, output and supply lines separately and not parallel to each other.
 - Sensor and interface lines should be arranged as twisted and screened cables. Do not run them close to current-carrying components or cables. Earth the screen at one end at the instrument on terminal TE.
 - Earth the instrument at terminal TE to the earth conductor. This line must have at least the same cross-section as the supply lines. Earth lines should be run in a star layout to a common earth point which is connected to the earth conductor of the supply. Do not loop the earth connections, i.e. do not run them from one instrument to another.
 - Do not connect additional loads to the supply terminals of the instrument.
 - The instrument is not suitable for installation in hazardous areas.
 - Apart from faulty installation, there is a possibility of interference or damage to controlled processes due to incorrect settings on the controller (setpoint, data of parameter and configuration levels, internal adjustments). Safety devices independent of the controller, such as overpressure valves or temperature limiters/monitors, should always be provided and should be capable of adjustment only by specialist personnel. Please refer to the appropriate safety regulations in this connection. Since auto-tuning (self-optimisation) can not be expected to handle all possible control loops, there is a theoretical possibility of unstable parameter settings. The resulting process value should therefore be monitored for its stability.
 - The signal inputs of the controller must not exceed a maximum potential of 30 V AC or 50 V DC against TE.

4 Electrical connection

4.2 Connection diagram



The electrical connection must only be made by properly qualified personnel.

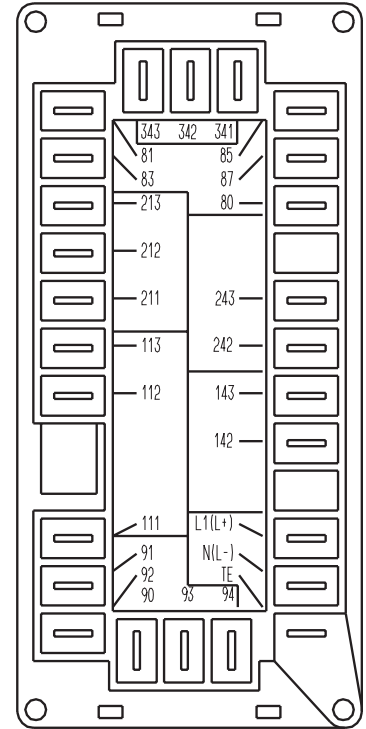
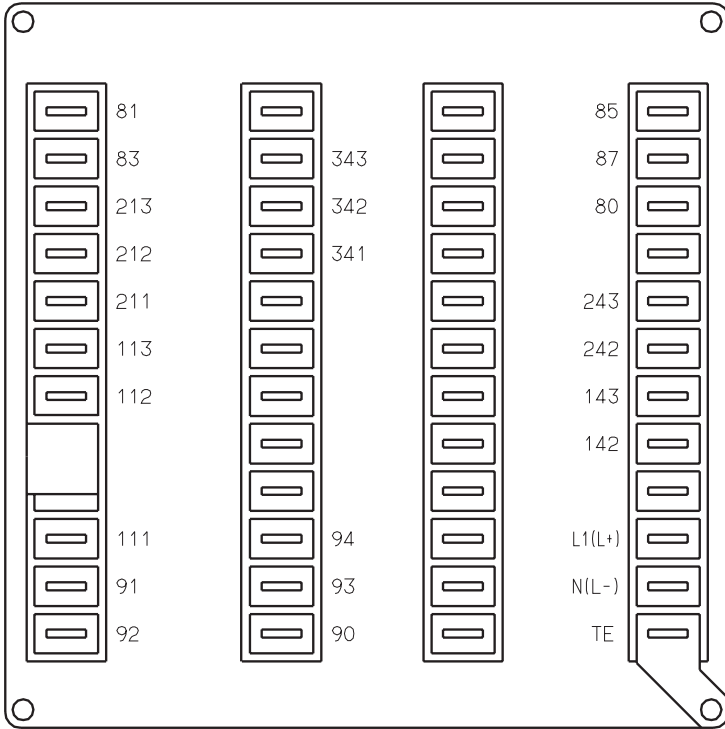

Outputs		Terminals	Symbol
Relay 1 ¹	K1	142 common 143 n.o. (make)	
Relay 2 ¹	K2	242 common 243 n.o. (make)	
Relay 3 ¹	K3	341 n.c. (break) 342 common 343 n.o. (make)	
or analogue output		342 - 343 +	
Logic output 1	K4	80 - 85 +	
Logic output 2	K5	80 - 87 +	

1. Varistor protection circuit S14K300

4 Electrical connection

Signal inputs		Input 1	Input 2	Symbol
Thermocouple		111 + 112 -	-	
Resistance thermometer in 3-wire circuit		111 112 113	-	
Resistance thermometer in 2-wire circuit Lead compensation through process value correction (OFFS)		111 112 113	-	
Potentiometer			211 S slider 212 E end 213 A start	
Current input		111 + 112 -	211 + 212 -	
Voltage input		111 + 112 -	211 + 212 -	
Heater current input 0—50 mA AC		-	211 212	
Serial interface RS422	RxD	91 RxD + 92 RxD -	Receive Data	
	TxD	93 TxD + 94 TxD -	Send Data	
	GND	90 GND		
Serial interface RS485	RxD/ TxD	93 RxD/TxD+ 94 RxD/TxD	Receive/Send Data	
	GND	90 GND		
Logic input 1		81 80		
Logic input 2		83 80		
Supply as on label	AC/ DC	AC: L1 line N neutral TE technical earth	DC: L+ L-	

5 Preparation

5.1 Display and keys

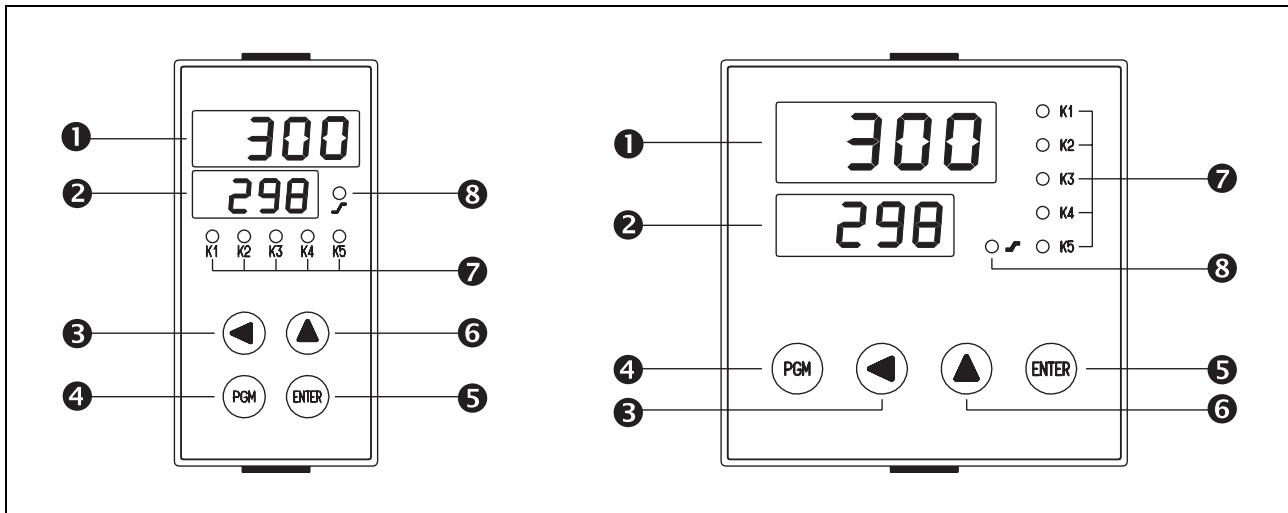

❶	process value display	7-segment display, red
❷	setpoint/heater current display	7-segment display, green
❸	digit key	to select the digit for inputs
❹	PGM key	to move on in the level scheme
❺	ENTER key	to enter the inputs
❻	increment key	to increase a digit value
❼	contact status indication ¹	to show the status of the five outputs
❽	LED for ramp function	lights up when a ramp function is activated

1. no function on analogue output K3

5.2 Operating mode and states

Standard display	the process value display shows the process value, the setpoint display shows the setpoint or the heater current
Initialising	all displays light up, the setpoint display is flashing
Manual operation	the process value display alternates between the process value and the word "Hand"; the setpoint display shows the controller output.
Ramp function/ start-up	the LED for ramp function lights up
Self-optimisation	the word "tune" is flashing
Operating, parameters, configuration	the setpoint display shows the parameters of the different levels, the process value display shows the corresponding codes and values.
Alarm	⇒ Chapter 15

5 Preparation

5.3 Principle of operation

5.3.1 Levels

Standard display

The displays show the setpoint and the process value.

From this status manual operation and self-optimisation can be activated.

 If heater current monitoring is activated, the heater current is shown on the setpoint display (value preceded by "H")

Operating level

Here the setpoints are input, the current controller output and the measurement of analogue input 2 are indicated.

Parameter level

The controller parameters and other settings are programmed here.

 It is possible to switch between two parameter sets.

 The display of the individual parameters depends on the controller type.

Configuration level

The basic functions of the controller are set here.

 Changes can only be made after calling up the configuration level via the parameter y.0 of the parameter level.

Within the levels the **PGM** key is used to switch over to the next parameter.

Time-out

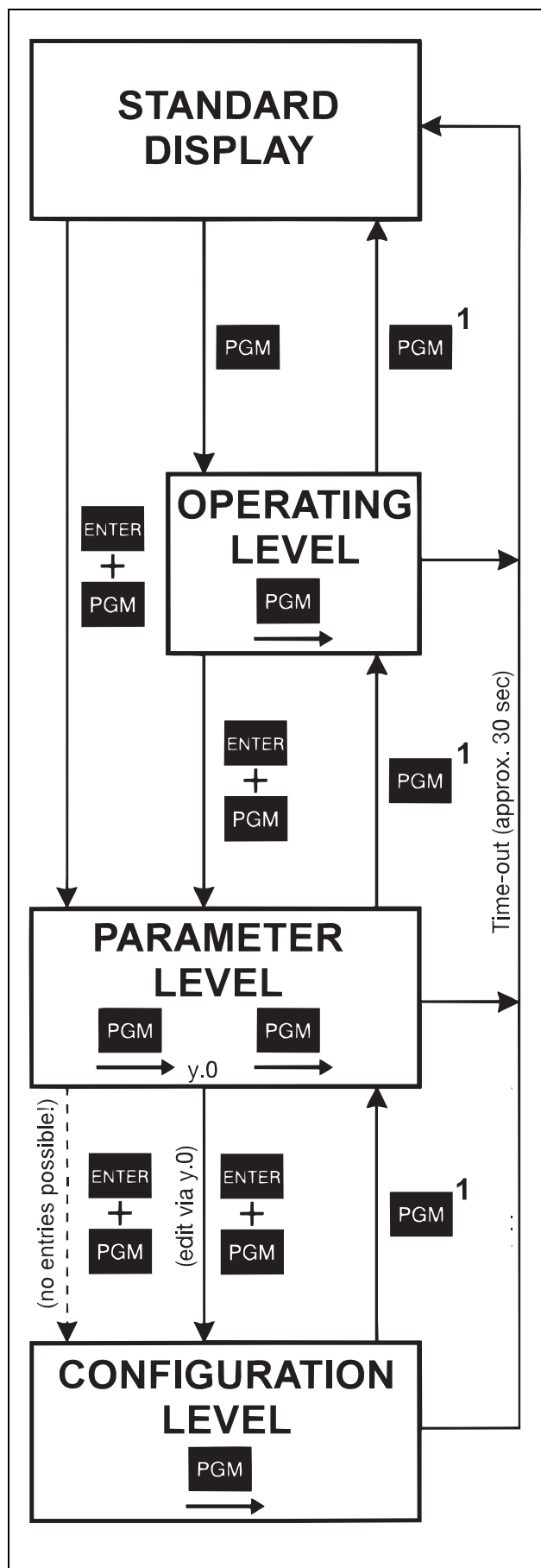

 If not operated, the controller returns automatically to standard display after approx. 30 sec.

1. A change of level occurs only after all parameters of the individual levels have been run through.



5 Preparation

5.3.2 Value input

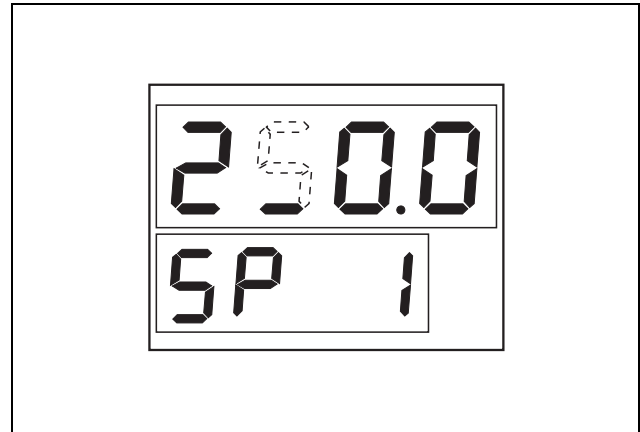

- * Select the digit with  (digit is flashing)
- * Alter the value with 
- * Repeat the operation for the other digits
- * Enter with 

 When inputting an illegal value, the maximum or minimum permitted value is flashing on the display. The input value is not entered.



Sign

The sign is altered on the first place on the left.

- * Position the cursor on the first digit with 
- * Alter the sign with  (hold down the key until "-1" or "-" appears)

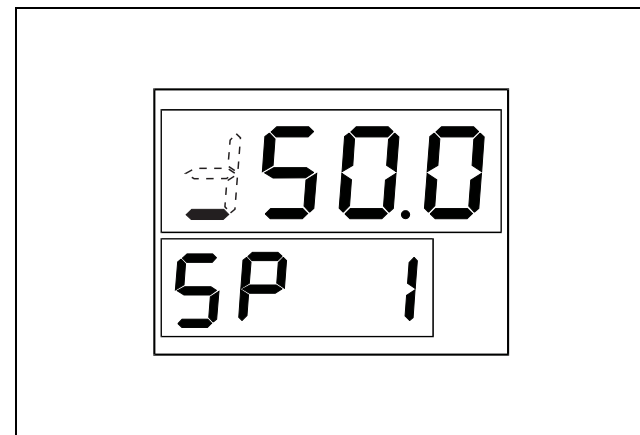

5.3.3 Programming the controller

The following procedure is recommended:

- * Fold out the sheet at the end of this Operating Manual
- * Transfer all parameter values and codes into the table provided for this purpose.
- * Program the controller according to the scheme indicated.

 The controller parameters appear in accordance with the controller type as configured.

 When altering the controller type (C212) it is essential to check the controller parameters.

6 Operation

6.1 Alter setpoints (SP1, SP2)

- * Change to setpoint SP1 with **PGM**
- * Alter the setpoint with **▲** and **◀**
- * Enter with **ENTER**
- * Change to setpoint SP2 with **PGM**
- * Alter the setpoint with **▲** and **◀**
- * Enter with **ENTER**
- * Return to standard display with 3x **PGM** or Time-out

6.2 Display controller output (y)

- * Change to output display with 3x **PGM**
- * Return to standard display with 2x **PGM** or Time-out

6.3 Display measured value on analogue input 2 (InP.2)

- * Change to measured value display with 4x **PGM**
- * Return to standard display with **PGM** or Time-out

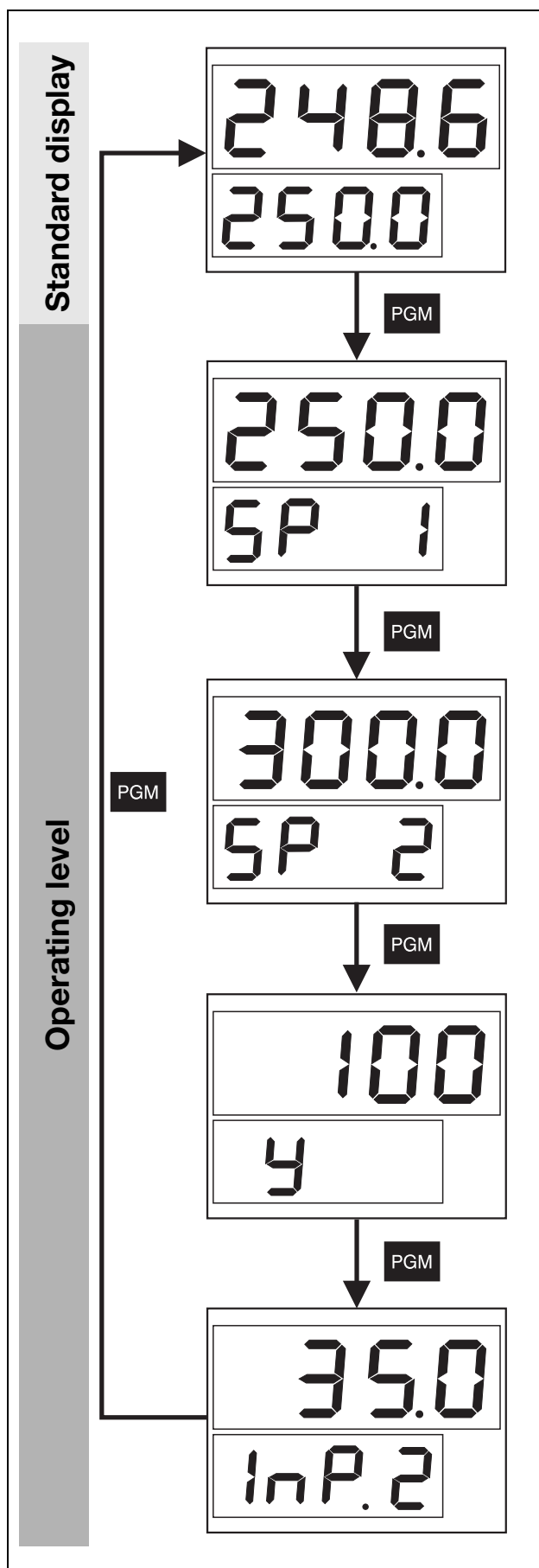

6 Operation

6.4 Activate manual operation

- * Change to manual operation with **ENTER** + **▲**
(The process value display alternates between the word "Hand" and the process value)
- * Alter the output with **▲** and **◀**
- * Enter with **ENTER**
- * Return to automatic operation with **ENTER** + **▲**

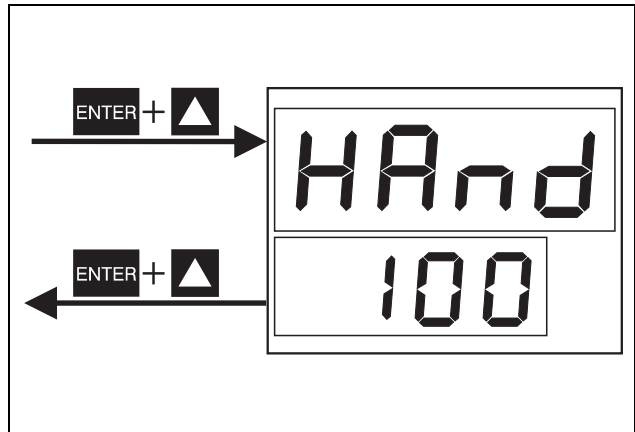

☞ Output limitation is activated during manual operation. Manual operation is locked as factory setting.

☞ **Modulating controller**

▲ - open valve

◀ - close valve

It is not necessary to enter with **ENTER**.

6.5 Start self-optimisation

- * Start self-optimisation with **ENTER** + **◀**

Self-optimisation is completed when the display is no longer flashing "tune".

- * Enter self-optimisation with **ENTER**
(hold down key for at least 2 sec!)
- * Abort with **ENTER**
(while self-optimisation is running).

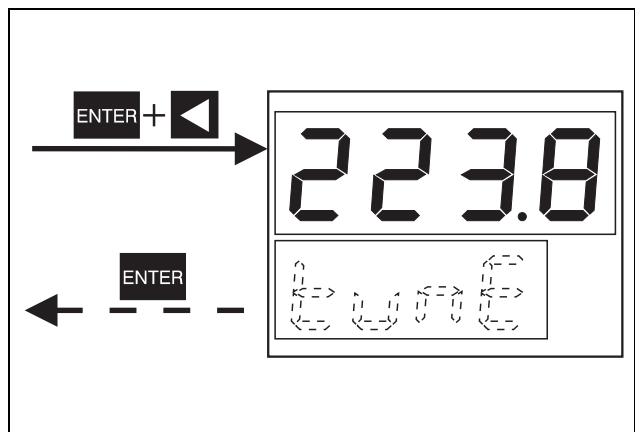

☞ Starting self-optimisation is not possible with activated level inhibit.

⇒ Section 9.1.1

6.6 Indicate software version and unit

- * Indicate the software version and the unit of the process value with **PGM** + **▲**
(Hold down keys!)

Possible units are:

°C, °F and % (for standard signals)

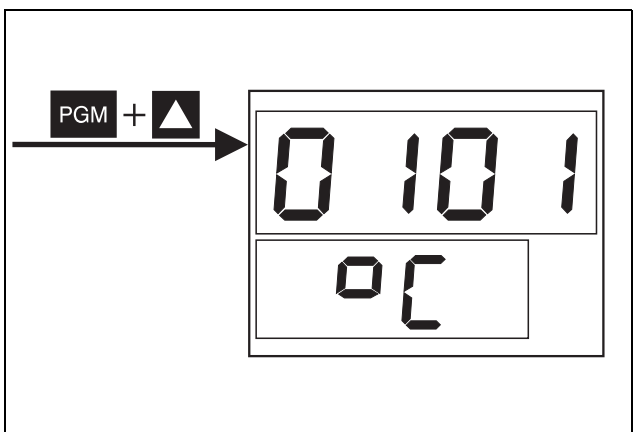

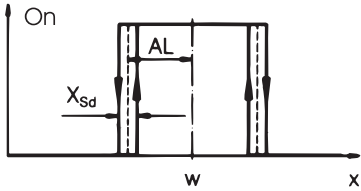
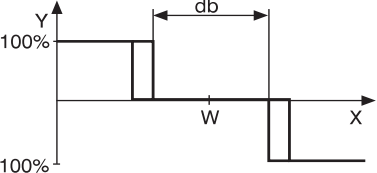

7 Parameters

Parameter	Display	Value range	Fact.set.	Notes
Setting limit comparator 1	AL 1	-1999 to 9999 digit (-199.9 to 999.9 digit) ¹	0 (0.0) ¹	 <p>⇒ Section 8.4, 14.2</p>
Setting limit comparator 2	AL 2	-1999 to 9999 digit (-199.9 to 999.9 digit) ¹	0 (0.0) ¹	
Proportional band 1	Pb. 1	0 to 9999 digit (0.0 to 999.9 digit) ¹	0 (0.0) ¹	Influences the P action of the controller. If Pb _{1,2} =0 the control structure is ineffective.
Proportional band 2	Pb. 2	0 to 9999 digit (0.0 to 999.9 digit) ¹	0 (0.0) ¹	
Derivative time	dt	0 – 9999 sec	80 sec	Influences the D action of the controller If dt=0 the controller has no D action. On modulating controllers dt=rt/4 or 0 has to be entered.
Reset time	rt	0 – 9999 sec	350 sec	Influences the I action of the controller. If rt=0 the controller has no I action.
Stroke time	tt	15 – 3000 sec	60 sec	On modulating controllers; utilised stroke time range of valve.
Cycle time 1	Cy 1	0.5 – 999.9 sec	20.0sec	Duration of switching cycle on switching outputs. The cycle time should be selected so that the energy supply to the process is virtually continuous while not subjecting the switching elements to excessive wear.
Cycle time 2	Cy 2	0.5 – 999.9 sec	20.0sec	
Contact spacing	db	0.0 – 100.0 digit	0.0	For switching double-setpoint controllers and modulating controllers. 

1. for setting Pt100 or standard signal with one decimal place.
 ⇒ Section 8.1

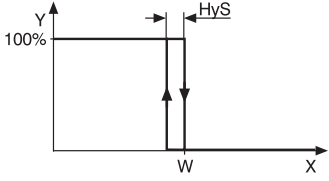
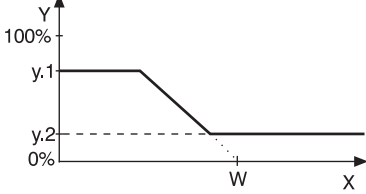
7 Parameters

Parameter	Display	Value range	Fact.set.	Notes
Differential 1	HyS. 1	0.1 – 999.9 digit	1.0	For controllers with Pb=0 
Differential 2	HyS. 2	0.1 – 999.9 digit	1.0	
Working point	y.0	-100 to +100 %	0 %	Output at x=w
Maximum output	y.1	0 – 100 %	100 %	Example: analogue controller with falling characteristic.  <p>  On controllers without controller structure (Pb=0) y.1 must be 100% and y.2 = 0% (y.2 = -100% on double-setpoint controllers) </p> <p>  On double-setpoint controllers without output limit y.2 = -100% must be set. </p>
Minimum output	y.2	0 – 100 % ¹ -100 to 0 % ²	0 % ¹ -100 % ²	
Filter time constant	dF	0.0 – 100.0 sec	0.6 sec	For adjusting the digital input filter
Ramp slope	rASd	0.0 – 999.9 digit/h or digit/min	0.0	⇒ Section 11.1, 11.2
Hold phase	tS	0 – 9999 min	0	ts is entered in parameter set 2 ⇒ Section 11.2

1. on single-setpoint controllers
2. on double-setpoint controllers

8 Configuration

8.1 C111 - Inputs

Analogue input 1- sensor type¹

Pt 100 without decimal place	0
Pt 100 with decimal place	1
Fe-Con L	2
NiCr-Ni K	3
Pt10Rh-Pt S	4
Pt13Rh-Pt R	5
Pt30Rh-Pt6Rh B	6
Cu-Con U	7
NiCrSi-NiSi N	8
Fe-Con J	9
Standard signal without decimal place	A
Standard signal with decimal place	b

Analogue input 1 - Standard signal²

0–20 mA / 0–10 V	0
4–20 mA / 2–10 V	1

Analogue input 2 - Function⁵

no function	0
Heater current display ³ (input: 0–50mA AC)	1
Output retransmission (input: potentiometer)	2
External setpoint ⁴ (input: 0–20mA/4–20mA)	3

Analogue input 2 - Standard signal²

0–20 mA / 0–10 V	0
4–20 mA / 2–10 V	1

0 0 0 0

1. On the basic controller, it is possible to reconfigure freely between the sensor types Pt100, all thermocouples and the standard signal 0–20mA/4–20mA (see second place from the left).
2. For the standard signal 0–10V/2–10V the hardware has to be reconfigured in the factory.
3. The measurement of the heater current is shown on the setpoint display and identified by the prefix H. The measurement range 0–50 mA AC is scaled to an indication range 0–50.0 A. The heater current monitoring of the measurement is implemented by configuring the limit comparators.
⇒ Section 8.4, 12.2
4. The input signal is scaled with the parameters SP.L and SP.H.
⇒ Section 8.9, 8.10
5. On the basic controller, it is possible to reconfigure freely between the functions “heater current display” and “external setpoint” (0–20mA/4–20mA). The functions “output retransmission” (potentiometer) or “external setpoint” (0–10V/2–10V) require a hardware reconfiguration in the factory.



The factory-set Codes are shown in the item boxes.
An "X" identifies a setting which depends on the instrument version (see footnote.)

8 Configuration

8.2 C112 - Logic inputs, ramp function, overrange, unit/supply

0	0	0	0
---	---	---	---

Function of the logic inputs

Logic input 1	Logic input 2	
no function	no function	0
Key inhibit	Parameter set switching ¹	1
Level inhibit	Parameter set switching ¹	2
Ramp stop	Parameter set switching ¹	3
Setpoint switching	Parameter set switching ¹	4
Key inhibit	Setpoint switching	5
Level inhibit	Setpoint switching	6
Ramp stop	Setpoint switching	7
Key inhibit	Ramp stop	8
Level inhibit	Ramp stop	9

Ramp functions

Ramp function and start ramp OFF	0
Ramp function ON, slope °C/min	1
Ramp function ON, slope °C/h	2
Start ramp ON, slope °C/min	3
Start ramp ON, slope °C/h	4

Signal on overrange

Output 0 %	Limit comparator OFF	0
Output 100 %	Limit comparator OFF	1
Output 50 % ^{2,3}	Limit comparator OFF	2
Output unchanged ⁴	Limit comparator OFF	3
Output 0 %	Limit comparator ON	4
Output 100 %	Limit comparator ON	5
Output 50% ^{2,3}	Limit comparator ON	6
Output unchanged ⁴	Limit comparator ON	7

Unit/Supply⁵

Degree Celsius	50 Hz	0
Degree Fahrenheit	50 Hz	1
Degree Celsius	60 Hz	2
Degree Fahrenheit	60 Hz	3

1. When programming the second parameter set, the floating contact of the logic input 2 has to be closed.
2. -100 % on double-setpoint controller.
3. On modulating controller the position of the actuator is retained.
4. The average value of the last eight outputs is retained.
5. The supply frequency must agree with the setting.

8 Configuration

8.3 C113 - Interface

		0	1	0	3
Instrument address					
Address 0 ¹		0	0		
Address 1		0	1		
Address 2		0	2		
Address 31		3	1		
Parity					
no parity	MODbus protocol			0	
odd parity	MODbus protocol			1	
even parity	MODbus protocol			2	
no parity	Jbus protocol			3	
odd parity	Jbus protocol			4	
even parity	Jbus protocol			5	
Baud rate					
1200 baud					0
2400 baud					1
4800 baud					2
9600 baud					3

1. Address 0 is a "broadcast instruction"; see Interface Description B 70.3030.2

8 Configuration

8.4 C211 - Limit comparators

0	0	0	2
---	---	---	---

Limit comparator 1

no function	0
lk 1 ¹	1
lk 2 ¹	2
lk 3	3
lk 4	4
lk 5	5
lk 6	6
lk 7	7
lk 8	8

Limit comparator 2

lk OFF	0
lk 1 ¹	1
lk 2 ¹	2
lk 3	3
lk 4	4
lk 5	5
lk 6	6
lk 7	7
lk 8	8

Input monitored

Limit comparator 1	Limit comparator 2	
Input 1	Input 1	0
Input 1	Input 2	1
Input 2	Input 1	2
Input 2	Input 2	3

Switching differential of limit comparators (X_{Sd})

0 digit	0
1 digit	1
2 digit	2
4 digit	3
6 digit	4
8 digit	5
10 digit	6
16 digit	7
20 digit	8

1. The condition $X_{Sd}/2 < AL$ must be met.



In the ramp function the limit comparators lk1 to lk6 refer to the ramp setpoint (=current setpoint). The limit values AL.1 and AL.2 are set at the parameter level.

8 Configuration

8.5 C212 - Controller type, manual operation inhibit, fuzzy function, output 3¹

X
0
0
X

Controller type²

Controller type	Controller output 1	Controller output 2	
Single-setpoint controller (heating)	O function	–	0
Single-setpoint controller (cooling)	S function	–	1
Double-setpoint controller (heating/cooling)	switching	switching	2
Double-setpoint controller (heating/cooling)	falling characteristic ³	switching	3
Double-setpoint controller (heating/cooling)	switching	rising characteristic ³	4
Modulating controller	open	close	5
Proportional controller (heating)	falling characteristic ³	–	6
Proportional controller (cooling)	rising characteristic ³	–	7

Manual operation inhibit/fuzzy function

Manual operation inhibited	Fuzzy OFF	0
Manual operation enabled	Fuzzy OFF	1
Manual operation inhibited	Fuzzy ON	2
Manual operation enabled	Fuzzy ON	3

Output 3 - Standard signal³

0–20 mA	0
4–20 mA	1
0–10 V	2
2–10 V	3

Output 3 - Function³

no function	0
Controller output 1	1
Controller output 2	2
Limit comparator 1	3
Limit comparator 2	4

1. Factory setting C212: 0000 on controllers without analogue output (K3); 6001 on controllers with analogue output (K3)
2. When the controller type is changed, the controller parameters have to be checked (for double-setpoint controllers, set y.2 = -100%).
3. An analogue output (output 3) must be available.

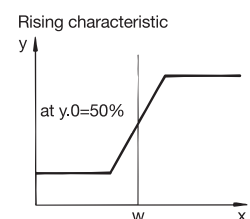
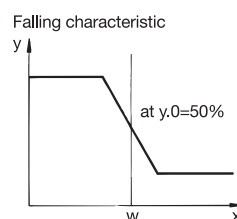
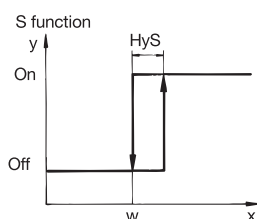
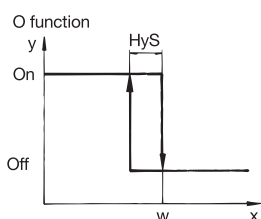

8 Configuration

8.6 C213- Functions of the outputs¹

	X	0	3	4
Output 1 - function (relay)				
no function	0			
Controller output 1	1			
Controller output 2	2			
Limit comparator 1	3			
Limit comparator 2	4			
Output 2 - function (relay)				
no function		0		
Controller output 1		1		
Controller output 2		2		
Limit comparator 1		3		
Limit comparator 2		4		
Output 4 - function (logic output)				
no function			0	
Controller output 1			1	
Controller output 2			2	
Limit comparator 1			3	
Limit comparator 2			4	
Output 5 - function (logic output)				
no function				0
Controller output 1				1
Controller output 2				2
Limit comparator 1				3
Limit comparator 2				4

1. Factory setting C213: 1034 on controllers without analogue output (K3);
0034 on controllers with analogue output (K3)

8 Configuration

8.7 SCL - Standard signal scaling

Start of value range for standard signals.

Example: 0—20 mA = 20— 200°C: SCL = 20

Value range: -1999 to 9999 digit/-199.9 to 999.9 digit¹

Factory setting: 0 digit

8.8 SCH - Standard signal scaling

End of value range for standard signals.

Example: 0—20 mA = 20—200°C: SCH = 200

Value range: -1999 to 9999 digit/-199.9 to 999.9 digit¹

Factory setting: 100 digit

8.9 SPL - Setpoint limit

Low setpoint limit/start of display with external setpoint

Inputs of setpoints below this limit are not accepted.

The value of SPL flashes on the display.

Value range: -1999 to 9999 digit/-199.9 to 999.9 digit¹

Factory setting: -200 digit

8.10 SPH - Setpoint limit

High setpoint limit/end of display with external setpoint

Inputs of setpoints above this limit are not accepted.

The value of SPH flashes on the display.

Value range: -1999 to 9999 digit /-199.9 to 999.9 digit¹

factory setting: 850 digit

8.11 OFFS - Process value correction

The offset can be used to correct the measured value by a certain amount up or down.

It also serves to provide lead compensation when connecting resistance thermometers in 2-wire circuit.

Value range: -1999 to 9999 digit /-199.9 to 999.9 digit¹

Factory setting: 0 digit

Examples:

measured value	offset	displayed value
294.7	+ 0.3	295.0
295.3	- 0.3	295.0

1. On Pt100 and standard signals with decimal place (C111).

9 Optimisation

9.1 Optimisation

9.1.1 Self-optimisation

The self-optimisation function (SO) is purely a software function and is incorporated in the controller. SO investigates the reaction of the process to steps in controller output using a special procedure. Through an extensive computing algorithm the process response (process value) is used to calculate the controller parameters for a PID or PI controller (set $dt = 0!$) and to store them. The SO procedure can be repeated as many times as required.

The SO operates by two different methods which are selected automatically depending on the dynamic condition of the process value and its separation from the setpoint at the start of optimisation. SO can be started from any dynamic process value condition.

If there is a large separation between process value and setpoint when SO is activated, a switching level is selected about which the process value performs a forced oscillation during the SO procedure. The switching level is chosen so that the process value does not exceed the setpoint, if possible.

With a small deviation between process value and setpoint, e.g. when the control loop has stabilised, a forced oscillation is produced about the setpoint.

The process data of the forced oscillation are recorded and used to calculate the controller parameters r_t , dt , $Pb.1$, $Pb.2$, $Cy1$, $Cy2$, as well as a filter time constant optimal for this process in order to filter the process value.

 Self-optimisation switches off the fuzzy logic.

9.1.2 Fuzzy logic

Activation of the fuzzy module can improve the setpoint response and the disturbance response of the controller.

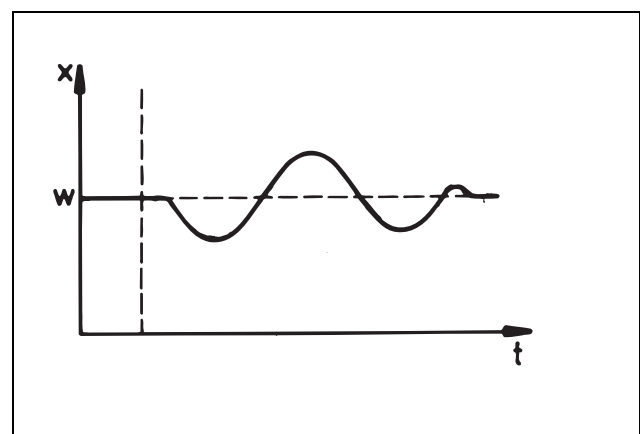
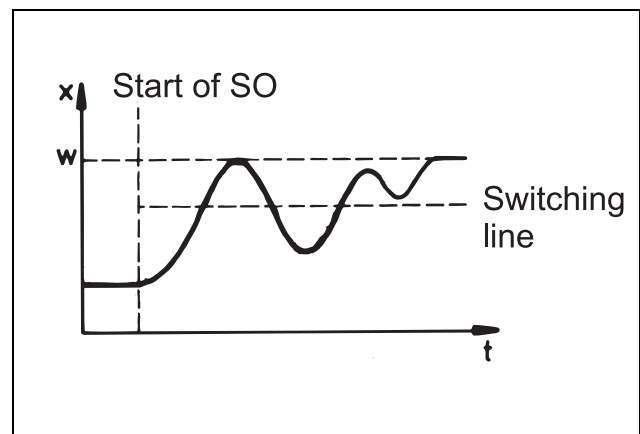
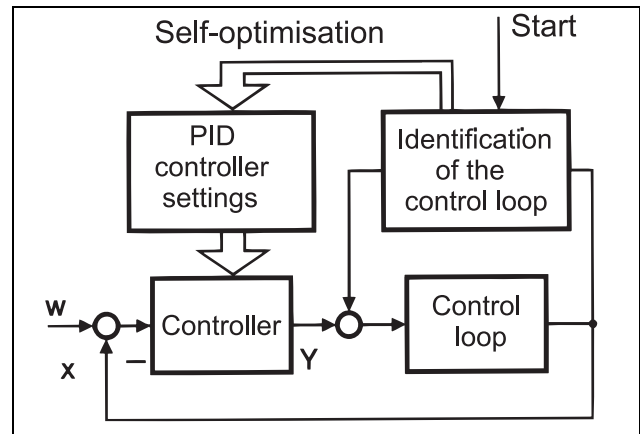

 Section 8.5

9 Optimisation

9.2 Checking the optimisation



The optimum adjustment of the controller to the process can be checked by recording a start-up with the control loop closed. The diagrams below indicate possible incorrect adjustments and their correction.

They are based on the control response of a third-order process for a PID controller. The procedure for adjusting the controller parameters can also be applied to other processes.

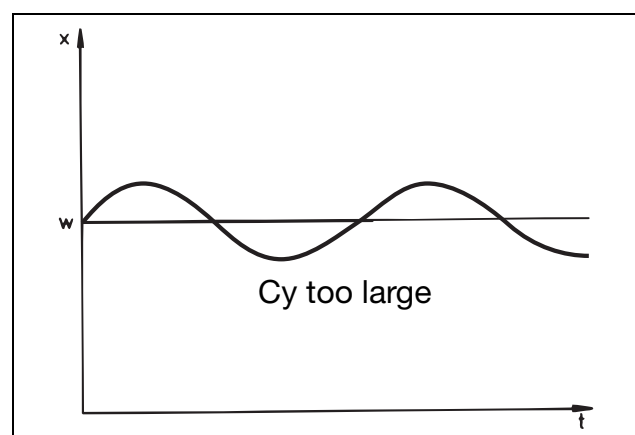
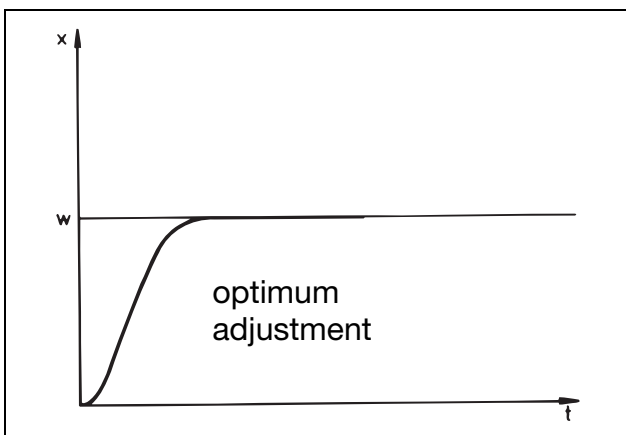
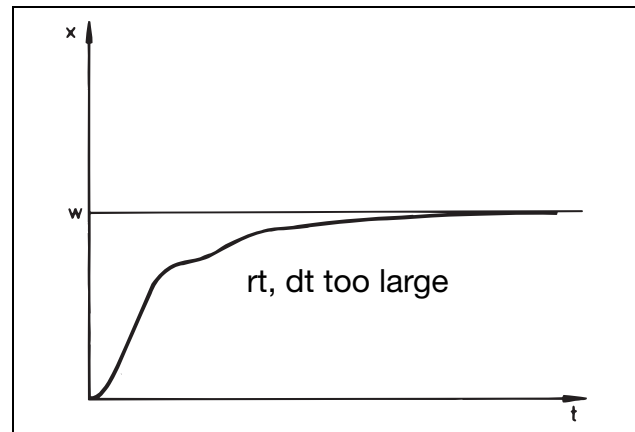
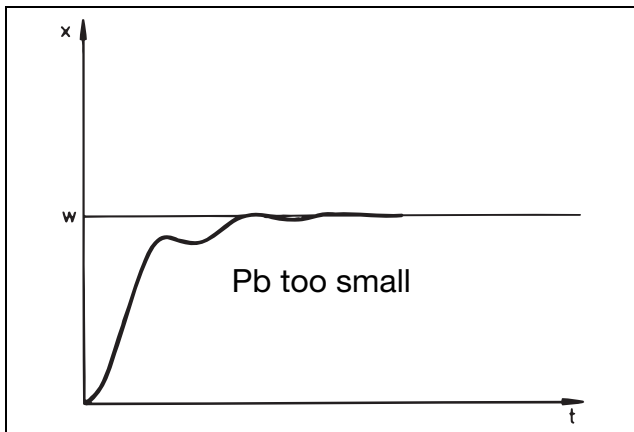
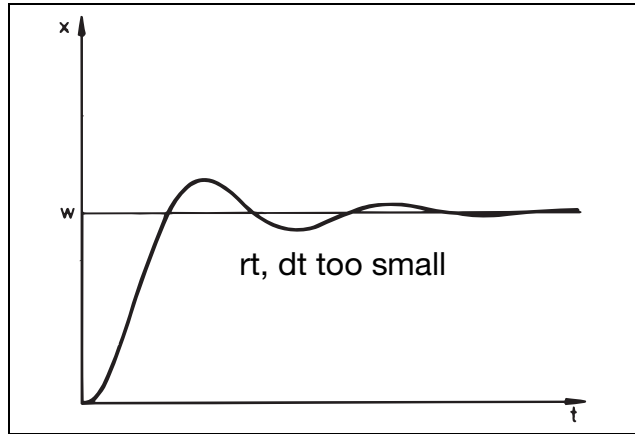
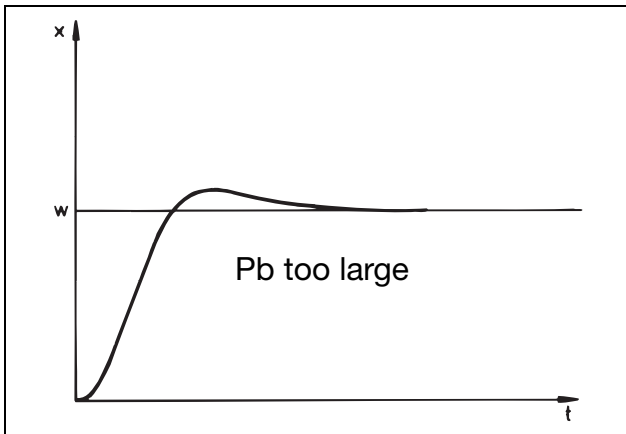
A favourable value for dt is $rt/4$.

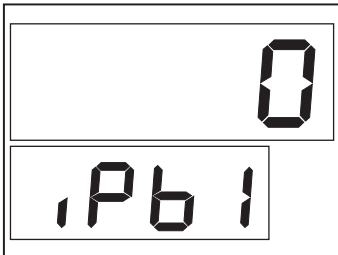
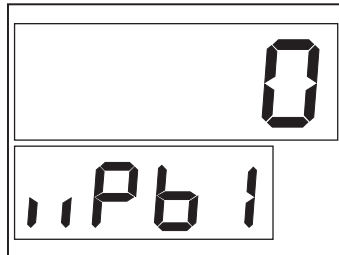

10 Logic inputs

		
Key inhibit	Operation is possible by keys.	No operation by keys.
Level inhibit	Access possible to parameter and configuration level. Starting of self-optimisation is possible.	No access to parameter and configuration level. No starting of self-optimisation.
Ramp stop	Ramp running. (If ramp function is activated!)	Ramp stopped. ⇒ Section 11.1
Setpoint switching	Setpoint 1 (SP1) is activated. The corresponding value is shown on the display.	Setpoint 2 (SP2) is activated. The corresponding value is shown on the display.
Parameter set switching¹	Parameter set 1 is activated. This status can be requested through parameter Pb1 at the parameter level.	Parameter set 2 is activated. This status can be requested through parameter Pb1 at the parameter level.
		

1. The following parameters are switched: Pb.1, Pb.2, dt, rt, tt, Cy1, Cy2, db, HyS.1, HyS.2, y.0, y.1, y.2, dF, rASd
⇒ Configuration via C 112

11 Ramp functions

11.1 Ramp function

Both a rising and a falling ramp function can be implemented. As soon as power is switched on, the current process value is set equal to the ramp setpoint and the setpoint runs according to the selected slope until the ramp end point SP is reached. The ramp end point is entered at the setpoint input. The ramp end point is now the current setpoint. When the ramp end point is reached, then $WR = SP$.

WR = ramp setpoint

SP = ramp end point

t_x = instant of alteration

Action on sensor break

On sensor break the ramp function is interrupted. The outputs act as for overrange or underrange (can be configured). When the fault has been rectified, the controller accepts the current process value as ramp setpoint and continues the ramp function.

Action on supply failure

When the supply is restored, the controller accepts the current process value as ramp setpoint and continues the ramp function with the set parameters.

Action during manual operation

During manual operation the ramp function is interrupted. After changing to automatic operation the current process value is accepted as the ramp setpoint and the ramp function continues with the set parameters.

Ramp stop

Activating the ramp stop via a logic input holds up the ramp function. The setpoint display is flashing. After the ramp stop has been de-activated, the ramp function continues with the ramp setpoint at the time of the ramp stop.

Ramp restart

The ramp can be restarted with the key combination **ENTER** + **▲**.

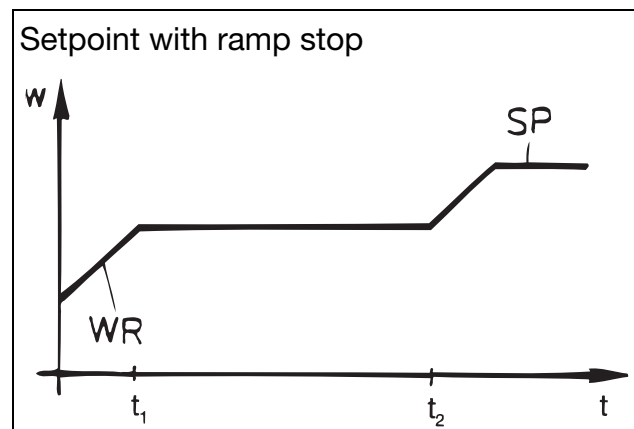
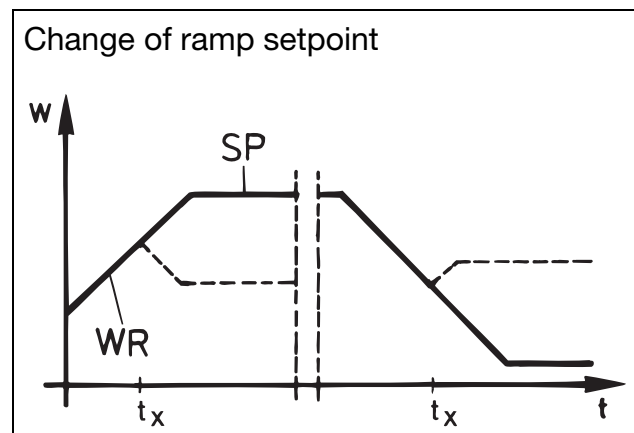
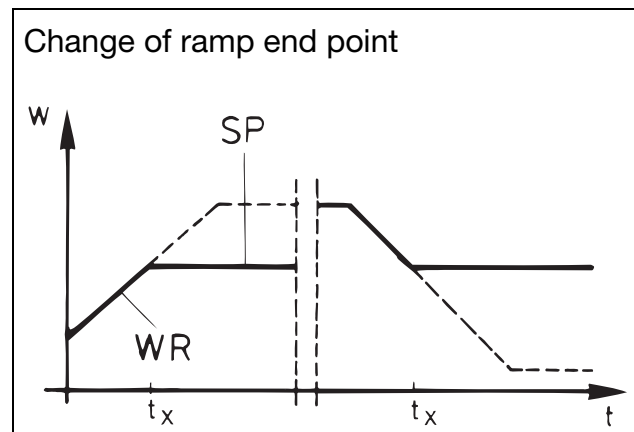
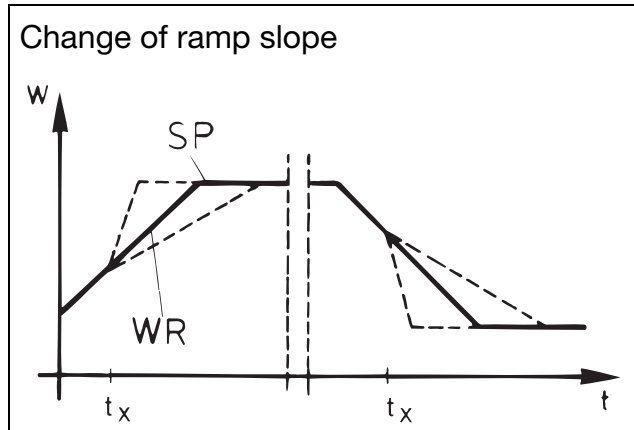

11 Ramp functions

11.2 Start-up ramp for hot-channel method

The start-up ramp for hot-channel method is used, for instance, for the safe operation of ceramic heating cartridges. During the start-up phase ($t_0 - t_2$) any moisture is allowed to escape slowly from the hygroscopic heating cartridges, thus preventing damage.

The start-up ramp begins at time t_0 and is also re-started after the following events (if start-up ramp C112 is activated):

- switching on the supply
- switching over from manual
- cancellation of overrange of the process value or sensor break
- Key combination **ENTER** + **▲**
- Altering the configuration (C 112)

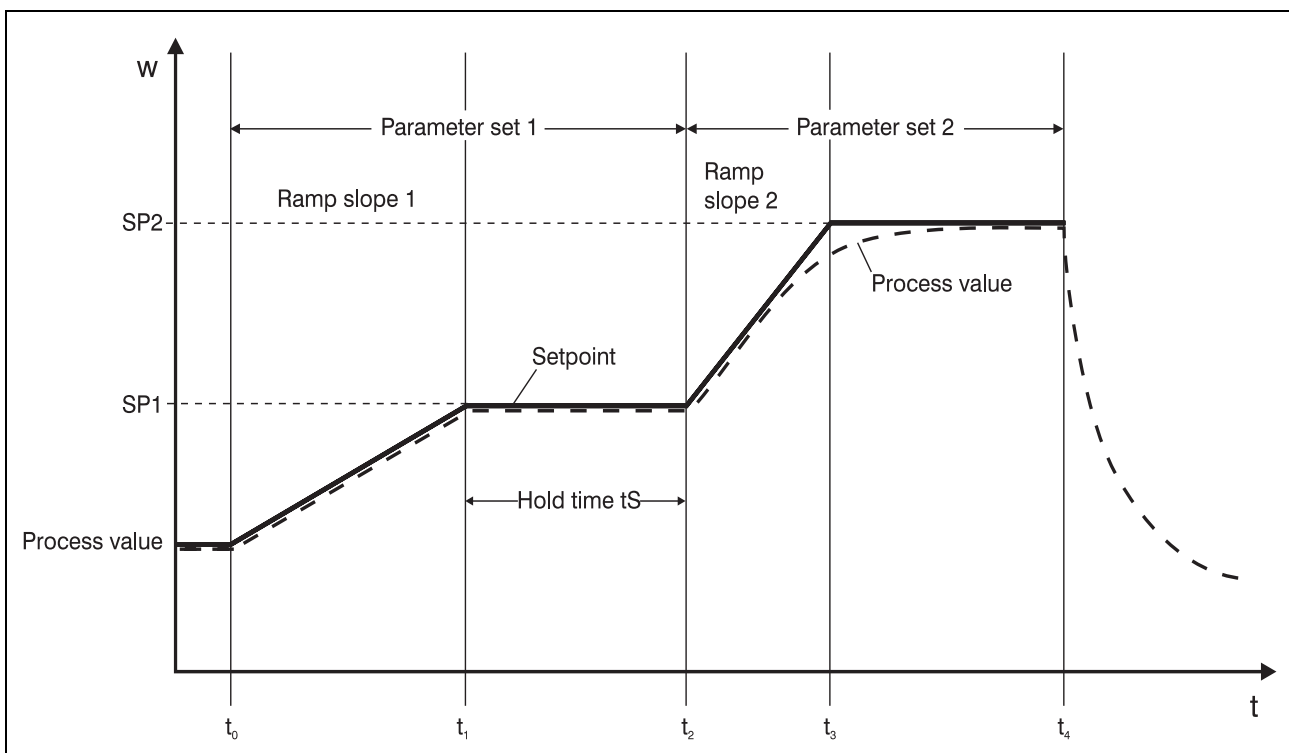

Two setpoints SP1 and SP2 are programmed. At time t_0 the process value is accepted as the ramp setpoint (=current setpoint as calculated and set by the controller). During the period $t_0 - t_1$ the setpoint SP1 is approached at the programmed ramp slope $rASd$. During this period there is a linear increase in the ramp setpoint. This is followed by a programmable hold phase tS ($t_1 - t_2$), and then the setpoint SP2 is approached at the second ramp slope $rASd$ (parameter set 2).

Different controller parameters can be set for the first phase and for the subsequent period.



If SP1 is above SP2, the process value is accepted as the ramp setpoint, and SP1 is approached with parameter set 1.

If SP1 is below SP2 and x is above SP1, then SP2 is approached with parameter set 2.

11 Ramp functions

Programming:



When the start-up ramp is configured, the time-out function is de-activated.

Initial status:

The start-up ramp is switched off (C112)

- * Set setpoint SP1 to 0
- * The condition $SP1 < SP2$ and $SP1 < x$ must be fulfilled.
- * Set start-up ramp via configuration code C 112
- * Program parameter set 1 until the operating level has been reached. (The display shows "SP1")
- * Change to parameter level with **ENTER** + **PGM**
- * Program parameter set 2 including hold time tS
- * Program the setpoints SP1 and SP2

Start the start-up ramp with 2x **ENTER** + **▲**
(in the standard display)

Altering the controller parameters while the start-up ramp is activated:



The current parameter set can be altered directly.

Altering parameter set 2 while parameter set 1 is activated:

- * Set setpoint SP1
Condition: $SP1 < \text{process value}$ and $SP1 < SP2$
- * Press the keys **ENTER** + **▲** (twice)
(in the standard display)
- * Alter the parameters
- * Set the required setpoint SP1
- * Start the ramp with 2x **ENTER** + **▲**
(in the standard display)

Altering parameter set 1 while parameter set 2 is activated:

- * Set setpoint SP1
Condition: $SP1 > \text{process value}$
- * Press the keys **ENTER** + **▲** (twice)
(in the standard display)
- * Alter the parameter
- * Set the required setpoint SP1
- * Start the ramp with 2x **ENTER** + **▲**
(in the standard display)

12 Heater current indication/monitoring

12.1 Heater current indication

Using a current transformer (ratio 1:1000) it is possible to measure and indicate the heater current via input 2.

The input signal range is 0–50mA AC. The input signal is scaled for an indication range of 0–50.0 A.

With appropriate configuration (configuration code C111=XX10), the measured value is shown on the bottom display preceded by the letter "H".

The measurement of the heater current takes place while the heating contact is closed. When the heating contact is opened, the leakage current is measured and indicated with a delay of 5 sec.

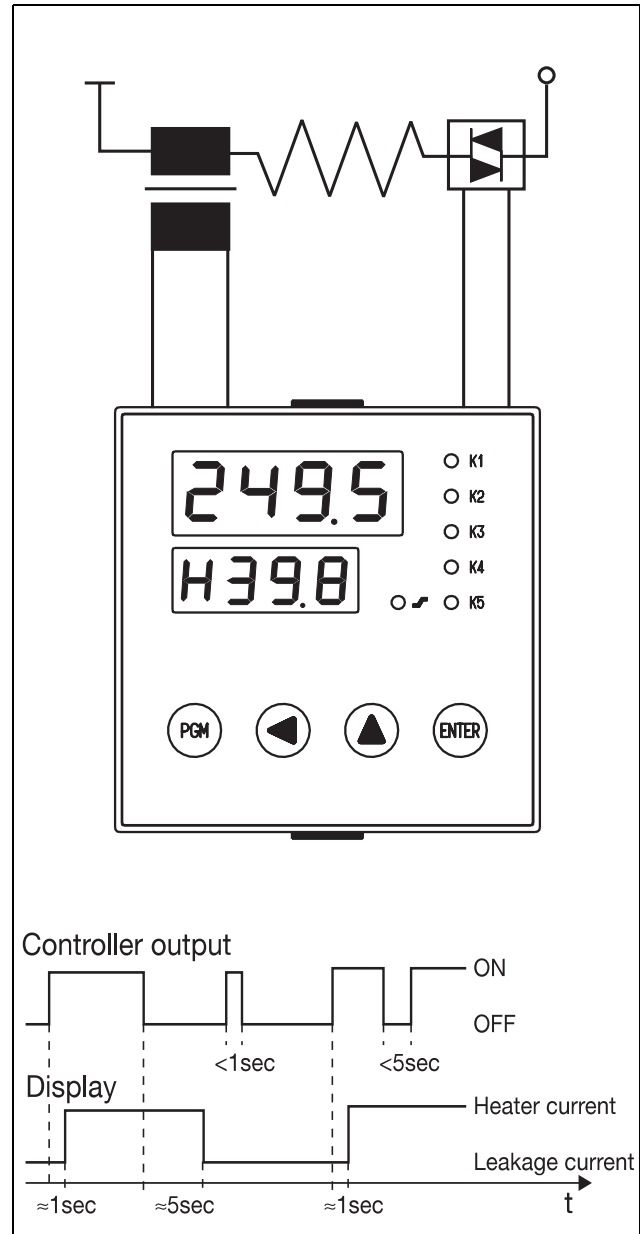

12.2 Heater current monitoring

The heater current can be monitored for overlimit (function Ik7) and/or underlimit (function Ik8) using two limit comparators.

Configuring heater current monitoring also provides leakage current monitoring. This is done internally using a limit comparator with function Ik7, a differential of 0 and a limit corresponding to 1 percent of that configured for heater current monitoring.

13 Interface

The controller can be integrated into a data network through the interface. The following applications can be realised, e.g.:

- process visualisation
- system control
- report

The bus system is designed according to the master-slave principle. A master computer can control up to 31 controllers and instruments (slaves). The interface is a serial interface with the standards RS422 or RS485.

The following data protocols are possible:

- MODbus protocol
- Jbus protocol



Interface description
B 70.3030.2



Retrofitting can only be performed in
the factory.

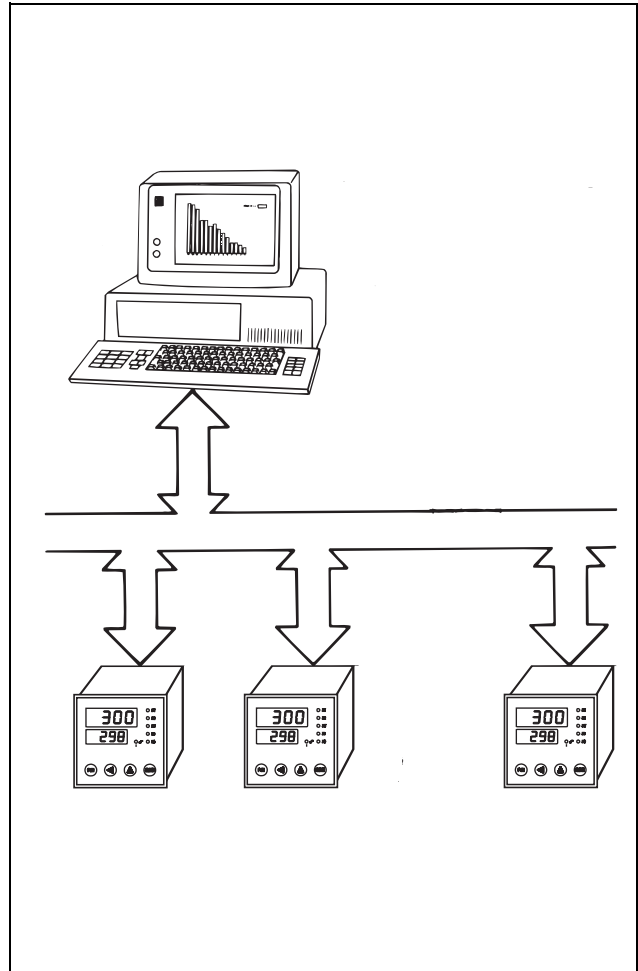

14 Limit comparator functions

Function Ik1

Window function: the output is ON when the measurement is within a certain range about the setpoint (w).

Example: $w = 200^{\circ}\text{C}$, $AL = 20$, $X_{Sd} = 10$

Measurement increasing: relay is energised at 185°C and de-energised at 225°C .

Measurement decreasing: relay is energised at 215°C and de-energised at 175°C .

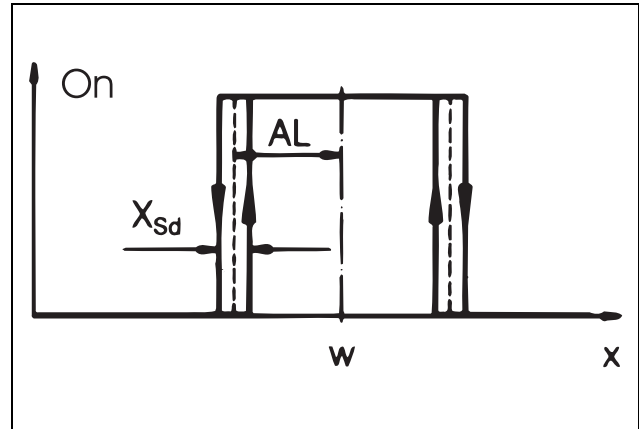

Function Ik2

as Ik1, but relay function reversed

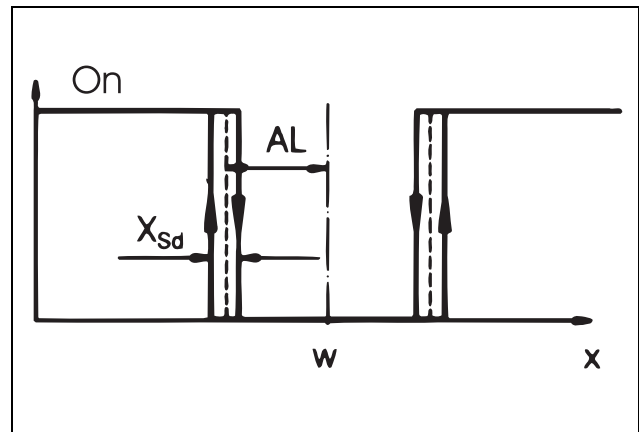

Function Ik3

low alarm

Function: output is OFF when measurement is below (setpoint-limit value)

Example: $w = 200^{\circ}\text{C}$, $AL = 20$, $X_{Sd} = 10$

Measurement increasing: relay is energised at 185°C .

Measurement decreasing: relay is de-energised at 175°C .

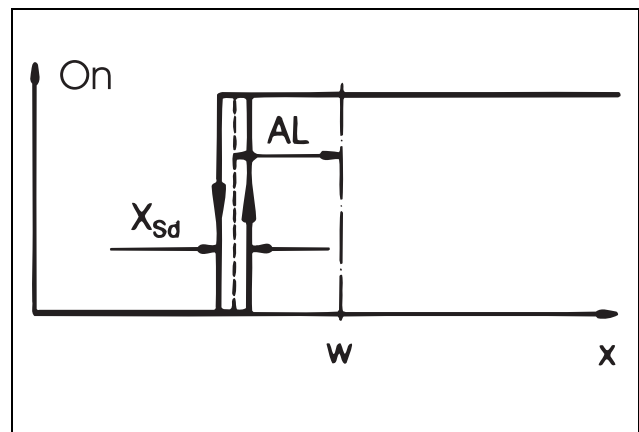

Function Ik4

as Ik3, but relay function reversed

w = setpoint
 x = measurement
 X_{Sd} = differential
 AL = limit value

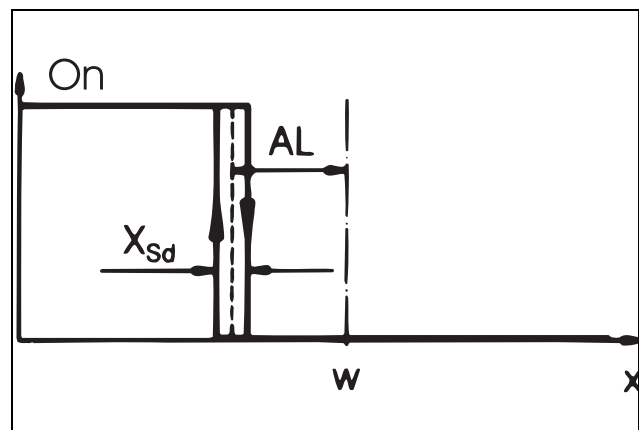

14 Limit comparator functions

Function Ik5

high alarm

Function: output is OFF when the measurement is above (setpoint+limit value).

Example: $w = 200^{\circ}\text{C}$, $AL = 20$, $X_{Sd} = 10$

Measurement increasing:

relay is de-energised at 225°C .

Measurement decreasing:

relay is energised at 215°C .

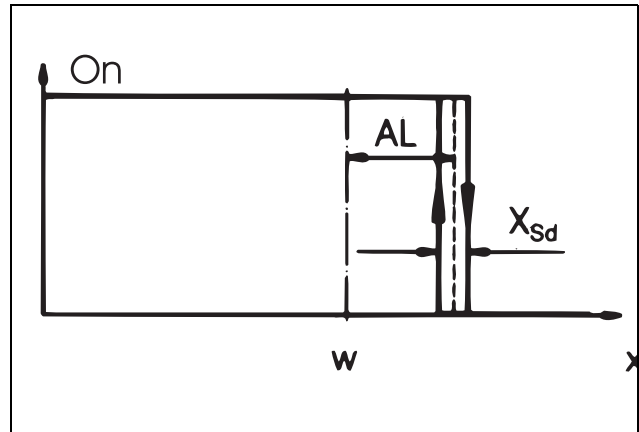

Function Ik6

as Ik5, but relay function reversed

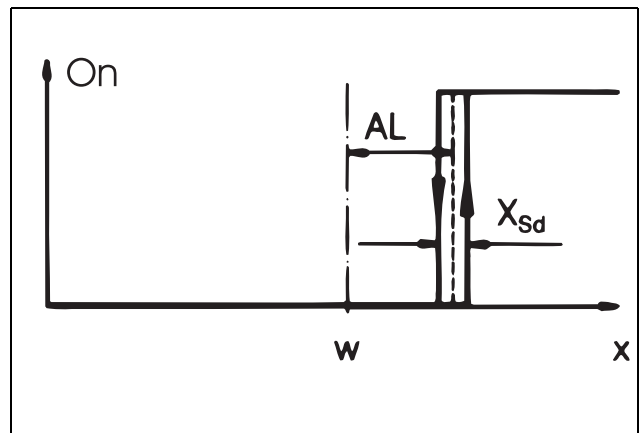

Function Ik7

Switching point is independent of controller setpoint and depends only on AL.

Function: output is ON when measurement is above limit value.

Example: $AL = 150$, $X_{Sd} = 10$

Measurement increasing:

relay is energised at 155°C .

Measurement decreasing:

relay is de-energised at 145°C .

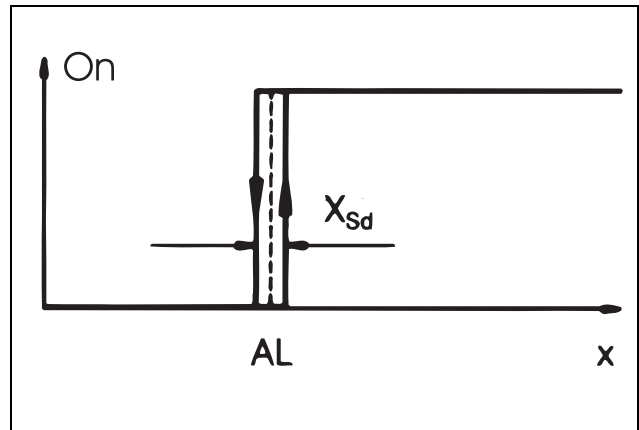

Function Ik8

as Ik7, but relay function reversed

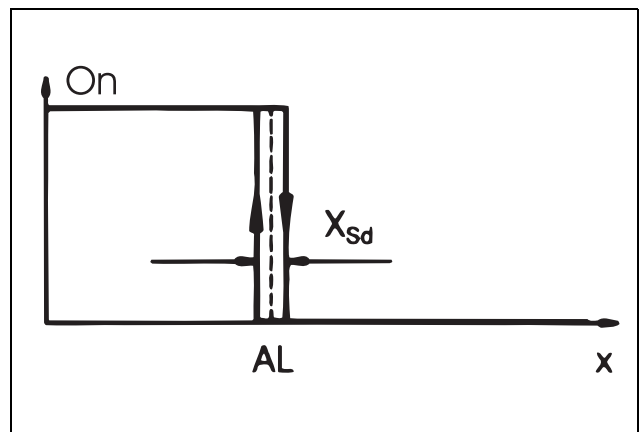

w = setpoint

x = measurement

X_{Sd} = differential

AL = limit value

15 Alarm messages

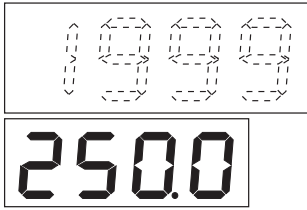
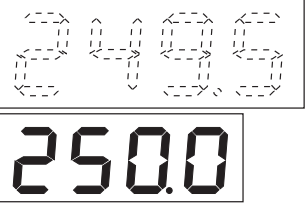
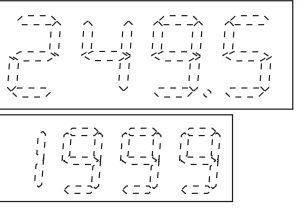
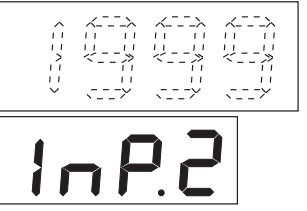
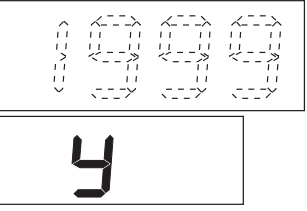
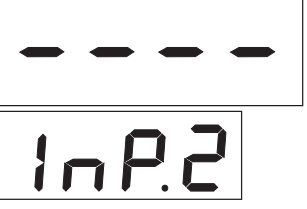
Display	Description	Cause/Action
	<p>Process value display flashes "1999". Setpoint display shows setpoint or heater current.</p>	<p>Overrange or underrange of measurement on input 1. Controller and limit comparators related to input 1 behave as configured (C112).</p>
	<p>Process value display flashes the process value. Setpoint display shows the setpoint when output retransmission has been configured.</p>	<p>Overrange or underrange of measurement on input 2. Modulating controller with output retransmission behaves as configured (C112); the same applies if external setpoint is programmed. Limit comparators related to input 2 behave as configured (C112).</p>
	<p>Process value display flashes the process value. Setpoint display flashes "1999" if heater current indication or external setpoint has been configured.</p>	
	<p>Operating level: If input 2 has a function, the process value display flashes "1999" when parameter "InP.2" is called up.</p>	
	<p>Operating level: If input 2 is configured for output retransmission, the process value display flashes "1999" when parameter "y" is called up.</p>	
	<p>Operating level: Process value display shows "----" when parameter "InP.2" is called up</p>	<p>Input 2 has no function</p>

-  Overrange and underrange is a combination of the following events:
- sensor break/short circuit
 - measurement is outside the value range of the connected sensor
 - indication overflow

16 Setpoint priorities

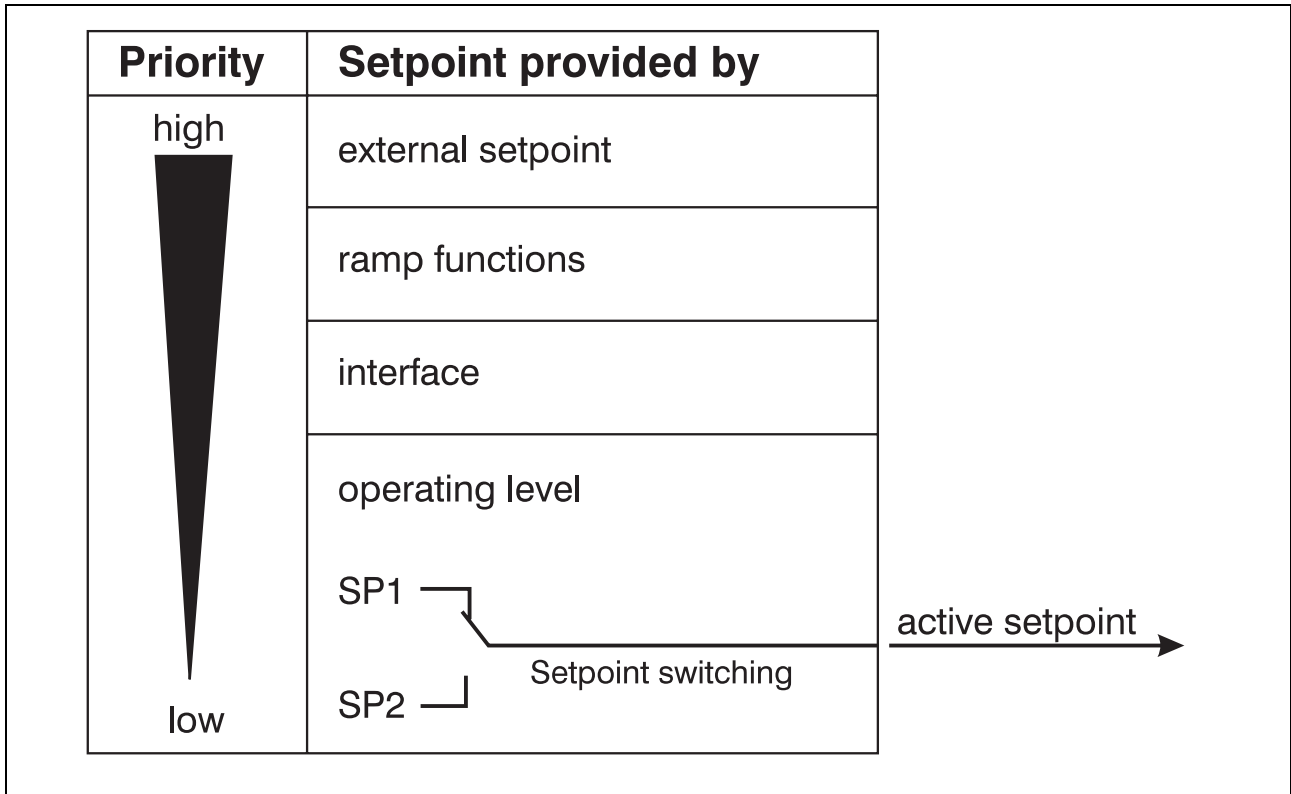

With activated ramp functions, no external setpoint provision is possible.

17 Technical data

Input 1

The change between Pt100, thermocouples, 0 – 20mA and 4 – 20mA can be configured in the software.

Voltage inputs 0(2) – 10 V require a hardware alteration in the factory.

Controller for use with resistance thermometers

Input

Pt100 in 2-wire or 3-wire circuit

Control range

–199.9 to +850.0°C

–200 to +850°C

Lead resistance: 30 Ω max.

Lead compensation

not required with 3-wire circuit.

When used with a resistance thermometer in 2-wire circuit, lead compensation can be provided by an external compensation resistor ($R_{comp} = R_{line}$). In addition, the lead resistance can be compensated in the software through process value correction.

Controller for use with thermocouples

Type	Range
Fe-Con L	–200 to + 900°C
Fe-Con J	–200 to +1200°C
NiCr-Ni K	–200 to +1372°C
Cu-Con U	–200 to + 600°C
NiCrSi-NiSi N	–100 to +1300°C
Pt10Rh-Pt S	0 to +1768°C
Pt13Rh-Pt R	0 to +1768°C
Pt30Rh-Pt6Rh B	0 to +1820°C

Temperature compensation: internal

Controller for use with linearised transducers with standard signal

Signals	Internal resistance R_i voltage drop ΔU_e
0(2) – 10 V	$R_i = 500 \text{ k}\Omega$
0(4) – 20 mA	$\Delta U_e = 1 \text{ V}$

Display with or without decimal place

Input 2

Change between 0(4) – 20mA (external set-point) and 0 – 50mA AC (heater current monitoring) can be configured in the software.

Voltage inputs 0(2) – 10 V and potentiometer input require a hardware alteration in the factory.

Controller for use with linearised transducers with standard signal

Signals	Internal resistance R_i voltage drop ΔU_e
0(2) – 10 V	$R_i = 500 \text{ k}\Omega$
0(4) – 20 mA	$\Delta U_e = 1 \text{ V}$

Display with or without decimal place

Controller for use with potentiometer

$R = 100 \text{ }\Omega$ to $10 \text{ k}\Omega$

Controller for use with current transformer (heater current monitoring)

Connection through current transformer (transformer ratio 1:1000)

0 – 50 mA AC sinusoidal

Scaling: 0 – 50.0 A

Outputs

2 relay outputs and 2 logic outputs are available as standard, 1 relay or analogue output as option.

1. Relay outputs K1/K2

n.o. (make) contact

Rating :

3 A 250 V AC on resistive load

Contact life:

more than 5×10^5 operations at rated load.

2. Relay output K3

changeover contact

Rating:

3 A 250 V AC on resistive load

Contact life:

more than 5×10^5 operations at rated load.

3. Logic outputs K4/K5

0/5 V

R_{load} more than 250 Ω

0/12 V

R_{load} more than 650 Ω

17 Technical data

4. Analogue output K3
 0(2) — 10 V R_{load} more than 500 Ω
 0(4) — 20 mA R_{load} less than 500 Ω
 isolation to the inputs:
 ΔU less than 30 V AC
 ΔU less than 50 V DC

General controller data

Controller type

Can be configured as single or double set-point controller, modulating or proportional controller

A/D converter: resolution better than 15 bit

Sampling time: 210 msec

Measurement accuracy	Ambient temperature error
when used with resistance thermometers 0.05% or better	25 ppm max. per °C
when used with thermocouples within the working range 0.25% or better*	100 ppm max. °C
when used with linearised transducers with standard signal 0.1% or better	100 ppm max. °C

These values include the linearisation tolerances.

* on Pt30Rh-Pt6Rh B within the range 300 — 1820°C

Measurement circuit monitoring

Transducer	Sensor break	Short-circuit
resistance thermometer	X	X
thermocouples	X	—
0 — 10V	—	—
2 — 10V	X	X
0 — 20mA	—	—
4 — 20mA	X	X

X = recognised — = not recognised

The outputs move to a defined status.

Data protection: EEPROM

Supply

93 — 263 V AC 48 — 63 Hz or
 20 — 53 V DC/AC 48 — 63 Hz

Power rating: 8 VA approx.

Electrical connection

through faston tags to DIN 46 244/A,
 4.8 mm x 0.8 mm

Permitted ambient temperature range

0 to +50°C

Permitted storage temperature range

–40 to +70°C

Climatic conditions

relative humidity not to exceed 75%,
 no condensation

Protection

to EN 60 529
 front IP 65
 back IP 20

Electrical safety

to EN 61 010
 Class 2
 clearance and creepage distances for
 - overvoltage category 2
 - pollution degree 2

Electromagnetic compatibility

to NAMUR recommendation NE 21
 EN 50 081 Part 1, EN 50 082 Part 2

Housing

for flush panel mounting to DIN 43 700,
 in conductive plastic, base material ABS,
 with plug-in controller chassis

Operating position

unrestricted

Weight

Type 703030: 430 g approx.
 Type 703031: 320 g approx.

Interface RS 422/RS485

isolated

Baud rate: 1200 — 9600 baud

Protocol: MODbus /Jbus

Instrument address: 1 — 31

Programming the controller

Start programming from the standard display.

- * Change to parameter level with **ENTER** + **PGM**
- * Continue switching with **PGM** until parameter y.0 appears on the display
- * Change to configuration level with **ENTER** + **PGM**

(The parameters appear in the sequence shown alongside. Certain parameters are omitted depending on the settings at the configuration level.)

- * Input the Code
- * Enter with **ENTER**
- * Continue switching with **PGM** to the subsequent parameters and input appropriate Codes and values until setpoint display SP1 appears.
- * Input the setpoint SP1
- * Continue switching with **PGM**
- * Input the setpoint SP2
- * Continue switching with **PGM**
- * Return to standard display with 2x **PGM**

Input of the second parameter set:

Start programming from the standard display.

- * Close the floating contact (parameter set switch-over)
- * Change to parameter level with **ENTER** + **PGM**
- * Input the values as above

Code				
C111				
C112				
C113				
C211				
C212				
C213				
SCL				
SCH				
SPL				
SPH				
OFFS				
Parameter	Parameter set 1	Parameter set 2		
AL1		-		
AL2		-		
Pb.1				
Pb.2				
dt				
rt				
tt				
Cy1				
Cy2				
db				
HyS1				
HyS2				
y.0				
y.1				
y.2				
dF				
rASd				
tS		-		

Fold-out



M. K. JUCHHEIM GmbH & Co

Hausadresse:

Moltkestraße 13 - 31, 36039 Fulda,
Germany

Lieferadresse:

Mackenrodtstraße 14, 36039 Fulda,
Germany

Postadresse:

36035 Fulda, Germany

Telefon: (06 61) 60 03-7 27

Telefax: (06 61) 60 03-5 08

E-Mail: mail@jumo.net

Internet: www.jumo.de

United Kingdom

JUMO Instrument Co. Ltd.

Temple Bank, Riverway

GB-Harlow,

Essex CM20 2TT

Phone (0 12 79) 63 55 33

Fax (0 12 79) 63 52 62

USA

JUMO PROCESS CONTROL INC.

7,5 Fox Chase,

Coatesville, PA 19320

Phone 610-380-8002, 800-554 JUMO

Fax 610-380-8009