

LOGOSCREEN AQUA 500

Multiparameter
Acquisition System for
Analytical Measurement

B 20.2595.0
Operating Manual

Visualization

ENTER Representation of measurement data

Event list

ENTER Display of events

Service and calibration

- ▲ ENTER Analog input 1
- Analog input 2
- ▼ Analog input 3
- Analog input 4
- Analog input 5
- Analog input 6

Disk manager

- ▲ ENTER Update diskette
- Disk. update incl. counter
- ▼ Compl. meas. data → diskette
- Config. data → diskette
- Diskette → config. data

Parameterization

- ▲ ENTER Contrast
- Speed indication
- ▼ Display off
- Diagram view
- Reset counter / int.

Instrument info

- ENTER Version number
- VdN number
- Input card 1
- Input card 2
- Digital I/O option
- Math option
- Counter/int. option
- Flash
- Error
- Power OFF
- Power ON
- Max. sample time

Configuration

- ENTER Instrument data
- Analog inputs
- Event traces
- ▲ Counter / integrator
- ▼ Measurement storage
- Outputs
- Control functions
- Texts
- Interface

1	General	6
1.1	Preface	6
1.2	Arrangement of the documentation	7
1.2.1	Structure of this operating manual	7
1.3	Typographical conventions	8
1.3.1	Warning signs	8
1.3.2	Note signs	8
1.4	Instrument description	9
2	Instrument identification	11
2.1	Type designation	12
2.2	Standard accessories	13
2.3	Optional accessories	13
3	Technical data	14
3.1	Analog inputs	14
4	Installation	20
4.1	Installation site	20
4.2	Mounting in position	20
4.3	Care of the front panel	21
5	Electrical connection	22
5.1	Installation notes	22
5.2	Connection diagram	23
5.3	Connecting a pH/ or redox measurement system using an impedance converter (>210 mV voltage source)	25
5.4	Connecting a pH/ or redox measurement system using a 2-wire transmitter (>210 mV voltage source)	25
5.5	Connecting a Pt100 temperature sensor	26
5.6	Connecting a conductivity transmitter (0(4) – 20 mA current source)	26
5.7	Connecting a transmitter for free chlorine (0(4) – 20 mA current source)	27
5.8	Connecting other transmitters (0(4) – 20 mA current source)	27

6	Description	28
6.1	Displays and controls	28
6.2	Operating principle and graphic elements	29
6.3	Analog inputs	31
6.3.1	Representation of the analog signals	31
6.3.2	Use of the analog signals	31
6.4	Digital inputs (extra code)	32
6.4.1	Representation of the digital signals	32
6.4.2	Use of the digital signals	32
6.5	Representation	33
6.5.1	Channel line (channel representation)	33
6.5.2	Event traces	34
6.6	Counters / integrators / oper. time counters (extra code)	35
6.6.1	Counters	35
6.6.2	Integrators	36
6.6.3	Operating time counter	36
6.6.4	Reporting periods of the counts	36
6.6.5	Resetting the counters / integrators / operating time counters	37
6.6.6	Response to instrument reconfiguration	38
6.7	Math / logic module	38
6.8	Operating modes	41
6.9	Data storage	42
7	Operation	44
7.1	Basic menu	44
7.2	Visualization	45
7.2.1	Diagram representation with digital display (small measurement)	46
7.2.2	Diagram representation with scaling	47
7.2.3	Diagram representation with bar graph	47
7.2.4	Large digital display (large measurement)	48
7.2.5	Curve representation (header switched off)	48
7.2.6	Evaluation of the stored measurement data	49
7.2.7	Counters / integrators / operating time	52
7.3	Service & calibration	53
7.4	Parameterization	54
7.5	Configuration	56
7.6	Event list	57

7.7	Disk manager	59
7.8	Instrument info	64
7.9	Text entry	66
7.10	Code number (password query)	67
8	Configuration parameters	69
8.1	Operating example	69
8.2	Before configuring	70
8.3	Configuration	71
8.4	Measurement-specific examples	71
8.5	Table of configuration parameters	71
8.5.1	Parameterization	71
8.5.2	Configuration - Instrument data	73
8.5.3	Configuration - Analog inputs	74
8.5.4	Configuration - Event traces	80
8.5.5	Configuration - Counter/integrator (extra code)	81
8.5.6	Configuration - Measurement storage	85
8.5.7	Configuration - Outputs (extra code)	86
8.5.8	Configuration - Control functions	87
8.5.9	Configuration - Texts	87
8.5.10	Configuration - Interface	88
8.5.11	Configuration - Fine calibration	88
9	Configuration examples	90
9.1	pH measurement	90
9.2	Redox measurement	94
9.3	Conductivity measurement	96
9.4	Measurement of free chlorine	100
9.5	Measurement of chlorine dioxide / ozone	106
9.6	Concentration measurement of sulfuric acid (H ₂ SO ₄)	108

10	Service & calibration	112
10.1	Entry of code number for the Service & calibration menu	112
10.2	General	113
10.3	Response to calibration	114
10.4	Logbook	117
10.5	Calibration parameters	119
10.6	Calibration	122
10.7	Table of service and calibration parameters	124
11	Calibration	129
11.1	Start	129
11.2	Calibrating pH electrodes	130
11.2.1	Basics	130
11.2.2	Calibrating a pH combination electrode (2-point calibration)	132
11.2.3	Logbook for the pH electrode	135
11.3	Calibrating with conductivity transmitters	136
11.3.1	Basics	136
11.3.2	Calibrating the cell constant of conductivity cells	137
11.3.3	Logbook of conductivity cell	139
11.4	Calibrating the temperature coefficient of a solution (for conductivity measurements)	140
11.4.1	Basics	140
11.4.2	Calibrating the temperature coefficient	140
11.4.3	Logbook for the temperature coefficient	143
11.5	Calibrating measuring cells for free chlorine	144
11.5.1	Basics	144
11.5.2	Calibrating a measuring cell for free chlorine	145
11.5.3	Logbook for the chlorine measuring cell	147
11.6	Calibrating measuring cells for chlorine dioxide or ozone	148
11.6.1	Basics	148
11.6.2	Calibrating measuring cells for chlorine dioxide or ozone	148
11.6.3	Logbook for the chlorine dioxide or ozone cell	151

12	Setup program	152
12.1	Hardware and software requirements	152
12.2	Installing the setup program	153
12.3	Data exchange between LOGOSCREEN AQUA 500 and PC	154
12.3.1	Data transfer via diskette	154
12.3.2	Data transfer via the setup interface	155
12.4	Customized linearization	157
12.5	Math and logic module	159
12.6	Character set (characters can be represented in setup program)	163
12.7	Character set (characters cannot be represented in setup program)	164
13	PC evaluation program	165
13.1	Program description	165
14	TÜV Report on Data Manipulation Security	167
15	Index	171

1 General

1.1 Preface

Please read this Operating Manual before commissioning the instrument. Keep the manual in a place that is accessible to all users at all times.

Please assist us to improve these operating instructions, where necessary.

Your suggestions will be appreciated.

Phone +49 661 6003-0

Fax +49 661 6003-607



All necessary settings are described in this manual. However, if any difficulties should still arise during start-up, please do not carry out any unauthorized manipulation on the unit. You could endanger your rights under the instrument warranty!

Please contact the nearest subsidiary or the head office in such a case.



When returning modules, assemblies or components, the regulations of EN 100 015 “Protection of electrostatically sensitive components” must be observed. Use only the appropriate **ESD** packaging for transport.

Please note that we cannot accept any liability for damage caused by ESD (electrostatic discharge).

1.2 Arrangement of the documentation

The documentation for this instrument consists of the following parts:

**Operating
Manual
B 20.2595**

This operating manual is included in the delivery. It is addressed to the equipment manufacturer and the user with appropriate technical expertise.

In addition to installation and electrical connection, it contains information on commissioning, operation and parameter setting on the instrument, as well as on the optional PC setup program and the optional evaluation program (PCA).

**Interface
Description
B 20.2595.2**

It provides information on the serial interface (RS232 and RS485), which can be supplied as an extra. The interface description can be used to develop specific programs that can, for instance, read out current measurement data.

1.2.1 Structure of this operating manual

This manual is arranged in a way which permits the user to enter directly into operation and configuration of the instrument. Consequently, chapters dealing with items that normally arise only once are placed at the end of the manual. These include instrument description, type designation, installation and electrical connection.

1 General

1.3 Typographical conventions

1.3.1 Warning signs



Danger

This symbol is used when there may be **danger to personnel** if the instructions are ignored or not followed correctly!



Caution

This symbol is used when there may be **damage to equipment or data** if the instructions are ignored or not followed correctly!

1.3.2 Note signs



Note

This symbol is used when your **special attention** is drawn to a remark.



Reference

This symbol refers to **further information** in other chapters or sections.

abc¹

Footnote

Footnotes are remarks that **refer to specific points** in the text. Footnotes consist of two parts:

A marker in the text, and the footnote text.

The markers in the text are arranged as continuous superscript numbers.

*

Action

This symbol indicates that an **action to be performed** is described.

The individual steps are marked by this asterisk.

Example:

* Clean electrode

* Press the  key.

1.4 Instrument description

Brief description

The LOGOSCREEN AQUA 500 is a universal acquisition system for a very diverse range of sensor signals.

In addition to current, voltage and temperature sensor signals, special measurement variables such as pH, redox potential, free chlorine, chlorine dioxide, ozone or conductivity and concentration measurement can also be acquired as input variables. The instrument can be equipped with three or six electrically isolated measurement inputs and offers many different recording functions.

Calibration procedures and temperature compensation, for instance for pH measurement, are integrated in the instrument. This eliminates the need for a separate, fully fitted pH transmitter.

The instrument can be programmed from eight keys or a PC (via diskette or serial interface).

The bezel size is 144mm x 144mm, depth behind panel 214mm.

Block diagram

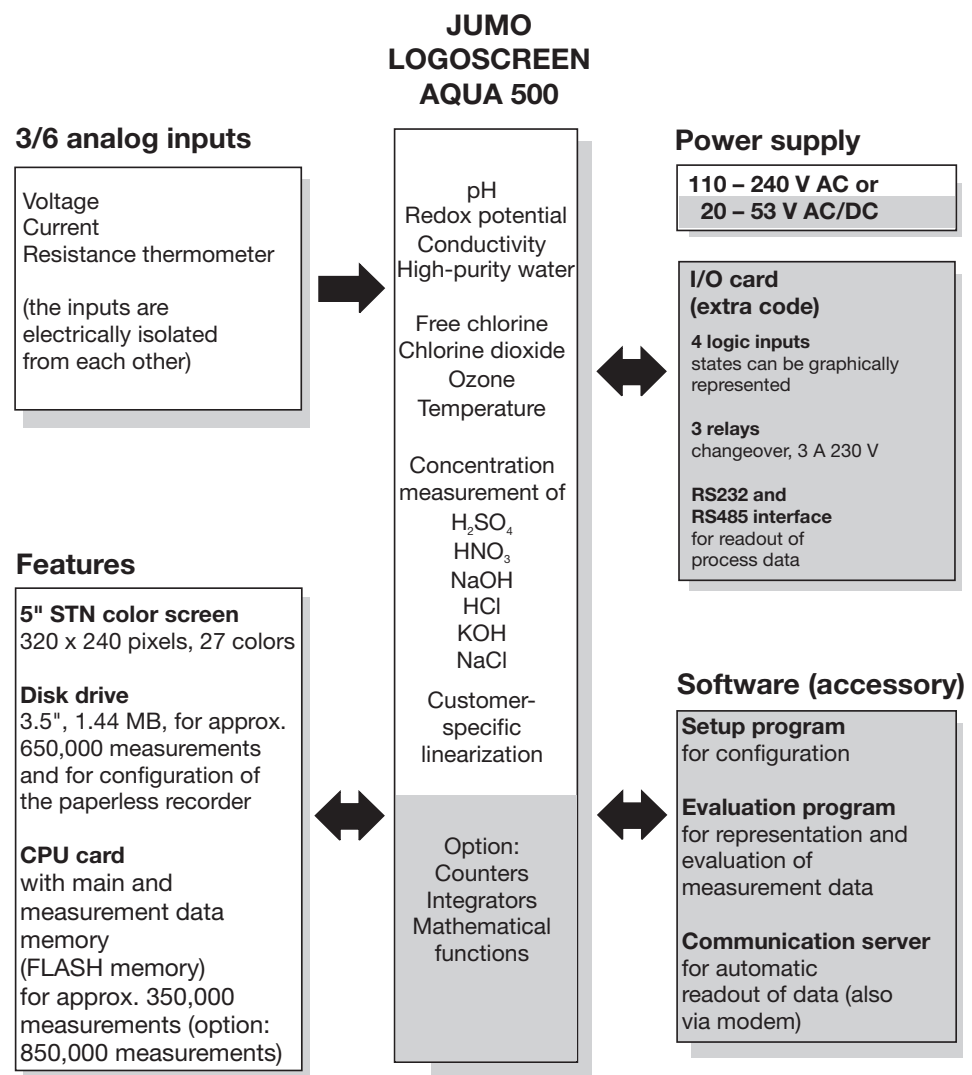

options

1 General

Features

Instrument-specific

- Recording functions: diagrams, event tracks, event list
- Evaluation of archived data via PC evaluation program
- Measurement data are retained, even after a power interruption
- Freely programmable inputs
- Counters and integrators
- Instrument configuration from the keys or through the setup program (diskette or serial interface)

pH measurement

- Connection of conventional pH electrodes via 2-wire transmitter or impedance converter
- Menu-led sensor calibration
- 1-, 2-, or 3-point calibration
- Automatic temperature compensation

Redox measurement

- Connection of conventional redox electrodes via 2-wire transmitter or impedance converter
- Zero-point calibration of sensor

Conductivity measurement

- Connection of conductive and inductive measuring cells via standard signal
- Calibration of cell constant and temperature coefficient
- Automatic temperature compensation
- Non-linear concentration curves are integrated (H₂SO₄, HNO₃, NaOH, etc.)
- High-purity water compensation to ASTM and USP

Measurement of free chlorine, chlorine dioxide and ozone

- Connection of the measuring cells via voltage or current signal
- Calibration of sensitivity
- pH and temperature-compensated chlorine measurement

For all measurement inputs

- Evaluation of the electrode condition in plain text
- Logbook on calibration procedures and sensor ageing

2 Instrument identification

Nameplate

The nameplate is affixed to the housing.

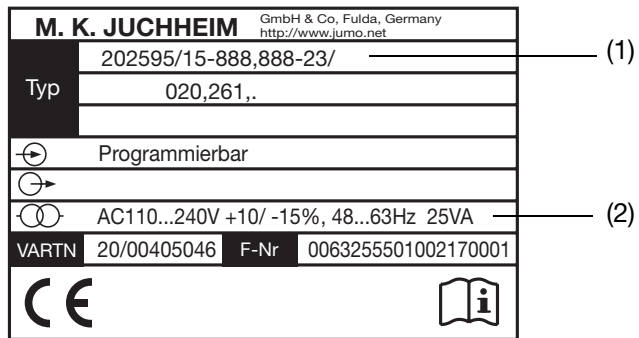

For an explanation of the type designation (1)
see Chapter 2.1 “Type designation”, Page 12.



The supply voltage must correspond to the voltage given on the nameplate (2).

2 Instrument identification

2.1 Type designation

(1) Basic version

				202595/14	with three analog inputs
				202595/24	with three analog inputs including setup and PCA evaluation programs
				202595/15	with six analog inputs
				202595/25	with six analog inputs including setup and PCA evaluation programs
x	x	x	x	888	(2) Inputs 1 – 3 (programmable) factory-set
x	x			000	(3) Inputs 4 – 6 (programmable) not used
		x	x	888	factory-set
x	x	x	x	22	(4) Supply 20 – 53V AC/DC, 48 – 63Hz
x	x	x	x	23	110 – 240V AC +10/-15%, 48 – 63Hz
x	x	x	x	020	(5) Extra codes lithium battery for memory buffering (ex-factory)
x	x	x	x	021	storage capacitor for memory buffering (on request)
x	x	x	x	260	integrators and counters / math and logic module ¹
x	x	x	x	261	four logic inputs, three relay outputs, serial interface RS232/RS485 (MODbus, Jbus)
x	x	x	x	264	memory expansion to 2MB ²
x	x	x	x	265	door with lock (IP54)
x	x	x	x	266	IP65 seal, wide mounting brackets
x	x	x	x	350	universal carrying case TG-35

Order code		(1)	(2)	(3)	(4)	(5)	,...			
		<input type="text"/>	<input type="text"/>	<input type="text"/>	<input type="text"/>	<input type="text"/>				
Order example		202595/14	-	888	-	000	-	23	/	020 ³

- ¹ The math and logic module can only be used in conjunction with the setup program.
- ² Memory expansion is only possible for new orders (not for retrofitting).
- ³ List extra codes in sequence, separated by commas.

2 Instrument identification

2.2 Standard accessories

- 1 Operating Manual B 20.2595.0
- 2 mounting brackets
- Cable tie with foot (can be released), for strain relief of the connecting cables to the sensor

2.3 Optional accessories

- Setup program on CD-ROM, multilingual
 - PC interface cable with TTL/RS232 converter and adapter
 - PC evaluation program (PCA) on CD-ROM, multilingual
 - PCA communication server on CD-ROM, multilingual
-

3 Technical data

3.1 Analog inputs

pH sensors via impedance converter

Indication range	Basic range	Compensation ¹	Accuracy
-1 to 14 pH	-600 to 600 mV	-50 to 250°C	±0.1% or 0.02 pH

Redox sensors via impedance converter

Indication range	Basic range	Compensation	Accuracy
-2000 to 2000 mV	-2000 to 2000 mV	not required	±0.1% or 4 mV

Conductivity measurement via conductivity transmitter

Indication range	Basic range	Compensation	Accuracy
0 to 2000 mS/cm	0 to 2000 mS/cm	linear 0 to 5.5%/°C; -50 to 250°C	see footnote ²

High-purity measurement via conductivity transmitter

Indication range	Basic range	Compensation	Accuracy
µS/cm	0 to 10 µS/cm	0 to 100°C, pollution by - salts - acidic media - alkaline media	see footnote ²
MΩcm	0 to 20 MΩcm		
ppm	0 to 10 ppm		

Measurement of free chlorine HOCl, e.g. via sensors as per Data Sheet 20.2630

Indication range	Basic range	Compensation	Accuracy
0 to 20 mg/liter	0 to 20 mg/liter	6.5 to 8.5 pH +5 to 45°C	see footnote ²

Measurement of chlorine dioxide ClO₂, e.g. via sensors as per Data Sheet 20.2630

Indication range	Basic range	Compensation	Accuracy
0 to 20 mg/liter	0 to 20 mg/liter	not required	see footnote ²

Measurement of ozone O₃, e.g. via sensors as per Data Sheet 20.2630

Indication range	Basic range	Compensation	Accuracy
0 to 20 mg/liter	0 to 20 mg/liter	not required	see footnote ²

Measurement of sulfuric acid H₂SO₄ via conductivity transmitter

Indication range	Basic range	Compensation	Accuracy
0 to 28 % weight (range I)	0 to 2000 mS/cm	0 to 100°C	see footnote ²
36 to 85 % weight (range II)	0 to 2000 mS/cm	0 to 115°C	
92 to 99 % weight (range III)	0 to 1000 mS/cm	0 to 115°C	

3 Technical data

Measurement of nitric acid HNO₃ via conductivity transmitter

Indication range	Basic range	Compensation	Accuracy
0 to 25 % weight (range I)	0 to 2000 mS/cm	0 to 80°C	see footnote ²
36 to 82 % weight (range II)	0 to 2000 mS/cm	-20 to 80°C	

Measurement of sodium hydroxide (caustic soda) NaOH via conductivity transmitter

Indication range	Basic range	Compensation	Accuracy
0 to 15 % weight (range I)	0 to 2000 mS/cm	0 to 90°C	see footnote ²
36 to 82 % weight (range II)	0 to 2000 mS/cm	0 to 90°C	

Measurement of hydrochloric acid HCl via conductivity transmitter

Indication range	Basic range	Compensation	Accuracy
0 to 18 % weight (range I)	0 to 2000 mS/cm	0 to 65°C	see footnote ²
22 to 44 % weight (range II)	0 to 2000 mS/cm	-20 to 65°C	

Measurement of potassium hydroxide (caustic potash) KOH via conductivity transmitter

Indication range	Basic range	Compensation	Accuracy
0 to 25 % weight (range I)	0 to 2000 mS/cm	0 to 60°C	see footnote ²
30 to 45 % weight (range II)	0 to 2000 mS/cm	-20 to 60°C	

Measurement of sodium chloride (common salt) NaCl solution via conductivity transmitter

Indication range	Basic range	Compensation within range	Accuracy
0 to 25 % weight (range I)	0 to 500 mS/cm	0 to 55°C	see footnote ²

¹ through manual entry or any channel

² dependent on the upstream transmitter and the input values of the LOGOSCREEN AQUA 500

Customized signal linearization within the permissible limits

50 freely definable value pairs, linear approximation, monotony

Additional variables in analytical measurement can be connected via current or voltage signals.

3 Technical data

Input DC voltage, DC current

Basic range	Accuracy ³	Input resistance
-20 to +70mV	±80µV	R _{IN} ≥ 1 MΩ
-3 to +105mV	±100µV	R _{IN} ≥ 1 MΩ
-10 to +210mV	±240µV	R _{IN} ≥ 1 MΩ
-0.5 to +12V	±6mV	R _{IN} ≥ 470 kΩ
-0.05 to +1.2V	±1mV	R _{IN} ≥ 470 kΩ
-1.2 to +1.2V	±2mV	R _{IN} ≥ 470 kΩ
-10 to +12V	±12mV	R _{IN} ≥ 470 kΩ
Shortest span	5mV	
Range start/end	freely programmable within the limits in 0.01 mV steps	
-2 to +22mA	±20µA	burden voltage ≤ 1V
-22 to +22mA	±44µA	burden voltage ≤ 1V
Shortest span	0.5mA	
Range start/end	freely programmable within the limits in 0.01 mA steps	
Overrange/underrange	according to NAMUR NE 43	
Sampling cycle	250 to 750msec, depending on variable to be measured and extent of calculation	
Input filter	2nd order digital filter; filter constant adjustable from 0 to 10.0sec	
Test voltage of electrical isolation	350V (via optocoupler)	
Resolution	> 14 bit	
Ambient temperature error	0.03 % / °C	

³ The accuracy refers to the maximum measurement range.
The accuracy is reduced with short spans.

Resistance thermometer

Designation	Standard	Connection circuit	Measuring range	Accuracy ³	Measuring current
Pt100	EN 60 751	2/3-wire	-200 to +100°C	±0.5°C	500µA
		2/3-wire	-200 to +850°C	±0.8°C	250µA
		4-wire	-200 to +100°C	±0.5°C	500µA
		4-wire	-200 to +850°C	±0.5°C	250µA
Pt500	EN 60 751	2/3-wire	-200 to +100°C	±0,5°C	250µA
		2/3-wire	-200 to +850°C	±0.8°C	250µA
		4-wire	-200 to +100°C	±0.5°C	250µA
		4-wire	-200 to +850°C	±0.5°C	250µA
Pt1000	EN 60 751	2/3-wire	-200 to +100°C	±0.5°C	500µA
		2/3-wire	-200 to +850°C	±0.8°C	250µA
		4-wire	-200 to +100°C	±0.5°C	500µA
		4-wire	-200 to +850°C	±0.5°C	250µA

3 Technical data

Designation	Standard	Connection circuit	Measuring range	Accuracy ³	Measuring current
Connection circuit		2-, 3-, or 4-wire circuit			
Shortest span		15°C			
Sensor lead resistance		max. 30 Ω per core with 3-/4-wire circuit max. 10Ω per core with 2-wire circuit			
Range start/end		freely programmable within the limits in 0.1°C steps			
Sampling cycle		3 or 6 channels 250msec			
Input filter		2nd order digital filter; filter constant adjustable from 0 to 10sec			
Test voltage of electrical isolation		350V (via optocoupler)			
Resolution		> 14bit			
Ambient temperature error		0.03%/°C			

³ The accuracy refers to the maximum measurement range.
The accuracy is reduced with short spans.

Transducer short circuit/break

	Short circuit ¹	Break ¹
Voltage (basic range) ≤ 210mV	not recognized	recognized
Voltage (basic range) > 210mV	not recognized	not recognized
pH / redox potential when using an impedance converter	not recognized	not recognized
Current	not recognized	not recognized
Resistance thermometer	recognized	recognized

¹ programmable response of instrument, e.g. alarm generation

Logic inputs (extra code)

Number	4, to DIN 19 240; 1 Hz max., 32V max.
Level	Logic "0": -3 to +5V, logic "1": 12 – 30V
Sampling cycle (logic inputs without counter function)	1 sec
Count frequency (logic inputs with counter function)	30Hz max.
Auxiliary voltage (output)	30mA, 24V (short-circuit-proof)

3 Technical data

Outputs (extra code)

3 relays	changeover (3A, 230V)
----------	-----------------------

Serial interface (extra code)

RS232/RS485	to read out measurement and instrument data (MODbus protocol)
-------------	---

Screen

Resolution	320 x 240 pixels
Size	5"
Number of colors	27 colors
Refresh rate	≥150Hz
Contrast	adjustable on instrument
Screen saving (switch-off)	through waiting time or control signal

Electrical data

Supply voltage (switch-mode PSU)	110 – 240V AC +10/-15%, 48 – 63Hz or 20 – 53V AC/DC, 48 – 63Hz
Supply voltage error	< 0.1% of range span
Power consumption	approx. 25VA
Data backup	memory backup: approx. 10 years with buffer battery or 2 weeks with capacitor
Electrical connection	at the back via plug-in screw terminals, conductor cross-section ≤ 2.5mm ² or 2x 1.5mm ² with ferrules
EMC - interference emission - immunity to interference	EN 61 326 Class B to industrial requirements
Safety regulation	to EN 61 010
Test voltages (type test)	to EN 61 010, Part 1 of March 1994 overvoltage category II, pollution degree 2
supply circuit to measuring circuit	with AC supply: 2.3kV/50Hz, 1 min, with AC/DC supply: 510V/50Hz, 1 min
supply circuit to housing (protective earth)	with AC supply: 2.3kV/50Hz, 1 min, with AC/DC supply: 510V/50Hz, 1 min
measuring circuits to measuring circuit and housing, electrical isolation between the analog inputs	350V/50Hz, 1 min up to 30V AC and 50V DC

3 Technical data

Housing

Housing type	housing for flush panel mounting to DIN 43 700, galvanized steel sheet
Bezel size	144 mm x 144 mm
Depth behind panel	214 mm including connectors
Panel cut-out	138 ^{+1.0} mm x 138 ^{+1.0} mm
Panel thickness	2 – 40 mm
Housing mounting	in panel to DIN 43 834
Operating position	unrestricted, taking account of the viewing angle of the screen, horizontal $\pm 50^\circ$, vertical $\pm 30^\circ$
Ambient temperature range	0 to +45°C
Storage temperature range	-20 to +60°C
Enclosure protection	to EN 60 529 category 2, front IP54, back IP20
Climatic conditions	$\leq 75\%$ relative humidity, no condensation
Weight	approx. 3.5 kg

4 Installation

4.1 Installation site

Conditions

The installation site should be free from vibration. Stray electromagnetic fields, e.g. from motors, transformers etc. should be avoided.

The ambient temperature at the location can be 0 to +45°C, at a relative humidity of $\leq 75\%$, no condensation.

4.2 Mounting in position

Outline drawing

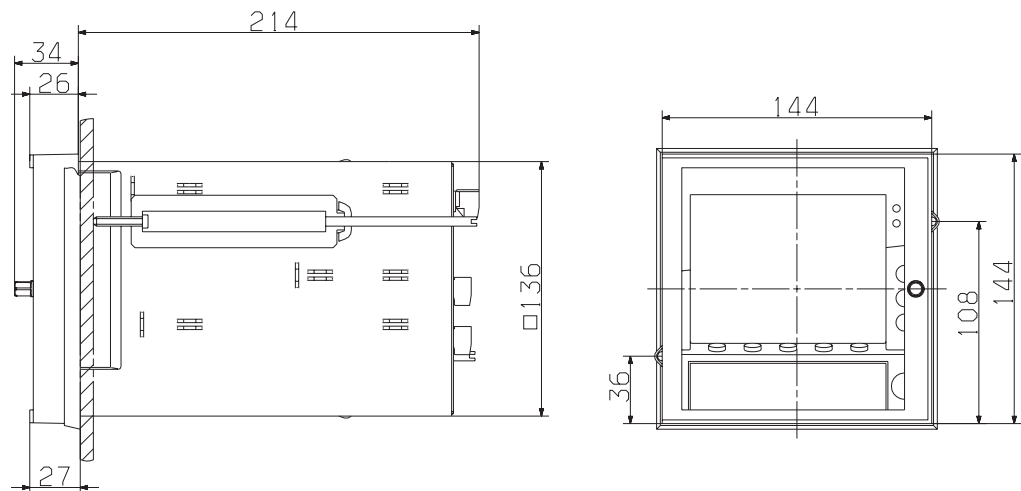

Size 26 increases to 27 when using the IP65 seal.

Panel cutout

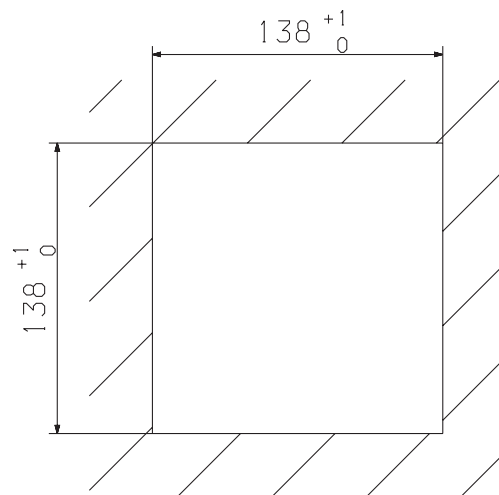

4.3 Care of the front panel

The front panel can be cleaned with normal commercial washing, rinsing and cleaning agents.

It has a limited resistance to organic solvents (e.g. methylated spirits, white spirit, P1, xylol etc.).



Do not use high-pressure cleaning equipment!

5 Electrical connection

5.1 Installation notes



The electrical connection must only be carried out by qualified personnel!

- The choice of cable, the installation and the electrical connection must conform to the requirements of VDE 0100 “Regulations on the Installation of Power Circuits with Nominal Voltages below 1000 V” or the appropriate local regulations.
 - The electrical connection must only be carried out by qualified personnel.
 - Work inside the instrument must only be carried out to the extent described and, like the electrical connection, only by qualified personnel.
 - The instrument must be completely disconnected from the electrical supply if contact with live parts is possible.
 - The load circuit must be fused for the maximum relay current, in order to prevent the output relay contacts becoming welded in the event of a short circuit.
 - Inductive loads close to the instrument, such as contactors or solenoid valves, should have RC modules fitted for interference suppression.
 - The electromagnetic compatibility conforms to EN 61 326.
 - Run input, output and supply cables separately and not parallel to one another.
 - All input and output cables without connection to the mains supply must be arranged as twisted and screened cables. Earth the screen on the instrument side to the earth potential.
 - Earth the instrument at the PE terminal to the protective conductor. This cable should have at least the same cross-section as used for the supply cables. Earthing cables must be wired in a star configuration to a common earth point that is connected to the protective conductor of the electrical supply. Do not loop earthing cables, i.e. do not run them from one instrument to another.
 - Do not connect any additional loads to the supply terminals of the instrument.
 - Sensor leads should be implemented as uninterrupted cables (**not** routed via terminal blocks etc.).
 - The instrument is not suitable for use in areas with an explosion hazard (Ex areas).
-

5 Electrical connection

5.2 Connection diagram



The electrical connection must only be carried out by qualified personnel!

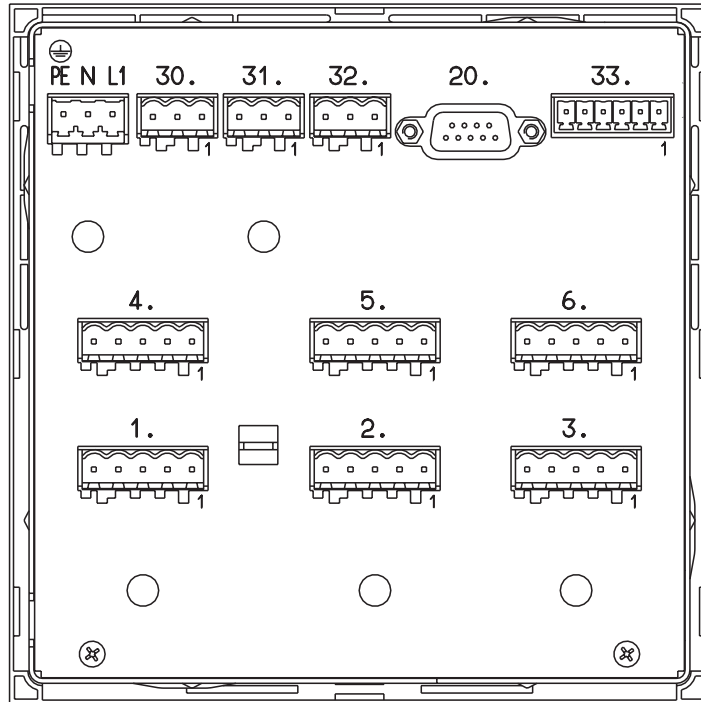

Terminal assignment (for pluggable screw terminals)		Diagram
Analog inputs	Connector	
Voltage input $\leq 210\text{mV}$	1 to 6	
Voltage input $> 210\text{mV}$ or pH or redox potential via impedance converter	1 to 6	
Current input	1 to 6	
Resistance thermometer in 2-wire circuit	1 to 6	
Resistance thermometer in 3-wire circuit	1 to 6	

5 Electrical connection

Resistance thermometer in 4-wire circuit	1 to 6	
---	--------	--

Supply		
Supply voltage	PE ⊕ N (L-) L1 (L+)	
Interfaces (extra code)		
RS232C 9-pole SUB-D socket	20	2 RxD receive data 3 TxD transmit data 5 GND ground
RS485 9-pole SUB-D socket	20	3 TxD+/RxD+ transmit/receive data + 5 GND ground 8 TxD-/RxD- transmit/receive data -
Relay outputs (extra code)		
Relay K1, K2, K3 (changeover)	30, 31, 32	
Logic inputs (extra code)		
Supply voltage 24V/50mA	33 6 +24V 5 GND	
Logic inputs voltage-operated	4 logic input 1 3 logic input 2 2 logic input 3 1 logic input 4	Example: logic input 4, operated from the internal supply voltage
Setup interface		
The setup interface can be found on the left side of the housing (seen from the front)		

5 Electrical connection

5.3 Connecting a pH/ or redox measurement system using an impedance converter (>210 mV voltage source)

Example

Connection to channel 1

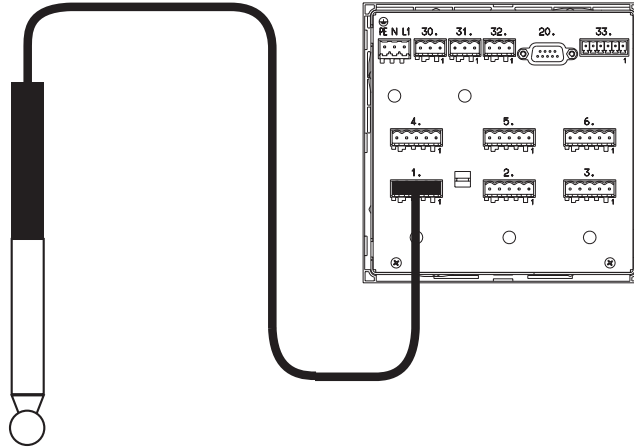

Terminal assignment, see Chapter 5.2 "Connection diagram", Page 23.

5.4 Connecting a pH/ or redox measurement system using a 2-wire transmitter (>210 mV voltage source)

Example

Connection of the 2-wire transmitter to channel 1.

Only operate a 2-wire transmitter from the internal power supply (terminal 33)!

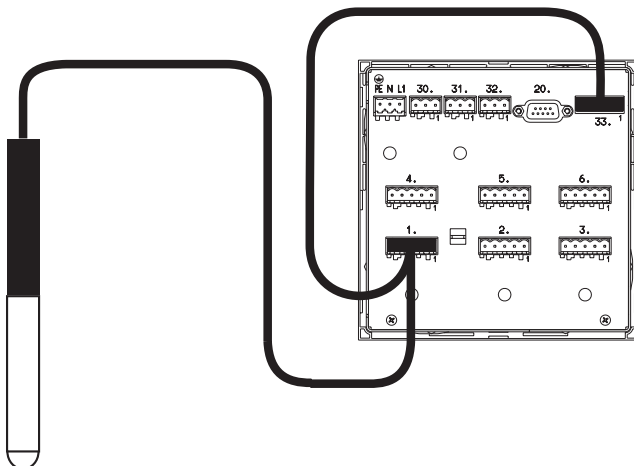

Terminal assignment, see Chapter 5.2 "Connection diagram", Page 23.

5 Electrical connection

5.5 Connecting a Pt100 temperature sensor

Example

Connection of a temperature sensor (Pt100 or Pt1000) in 2-wire circuit to channel 2

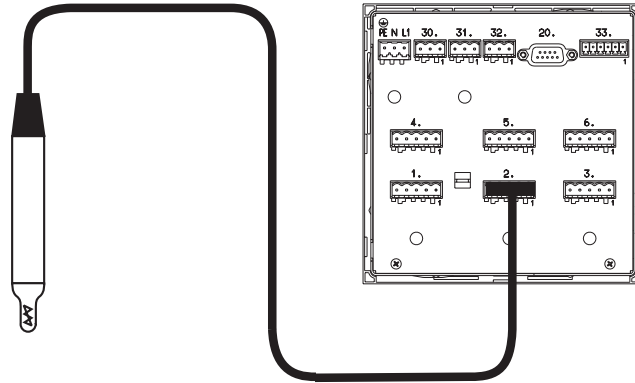

Terminal assignment, see Chapter 5.2 “Connection diagram”, Page 23.

5.6 Connecting a conductivity transmitter (0(4) – 20 mA current source)

Example

Connection of the conductivity transmitter to channel 1.

Connection of the signal for temperature compensation to channel 2

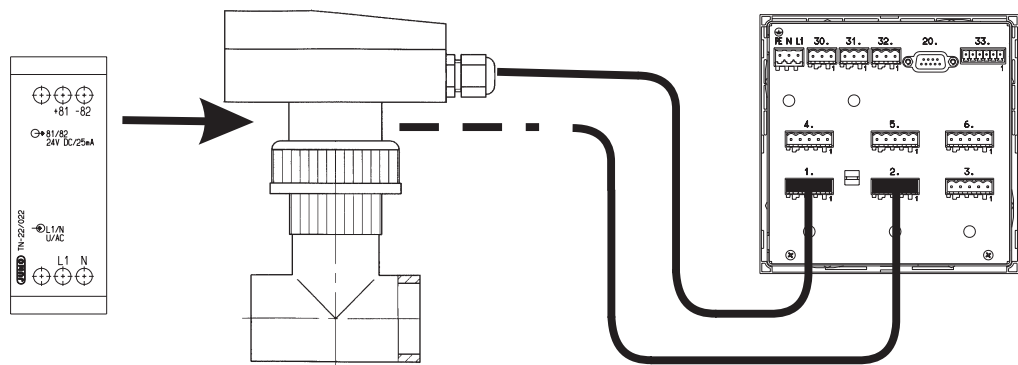

Terminal assignment, see Chapter 5.2 “Connection diagram”, Page 23.

5 Electrical connection

5.7 Connecting a transmitter for free chlorine (0(4) – 20 mA current source)

Example

Connection of a chlorine measuring cell (2-wire transmitter) to channel 1.
(Only operate a 2-wire transmitter from the internal power supply (terminal 33)!)
Connection of the signal for pH compensation to channel 2
Connection of the signal for temperature compensation to channel 3

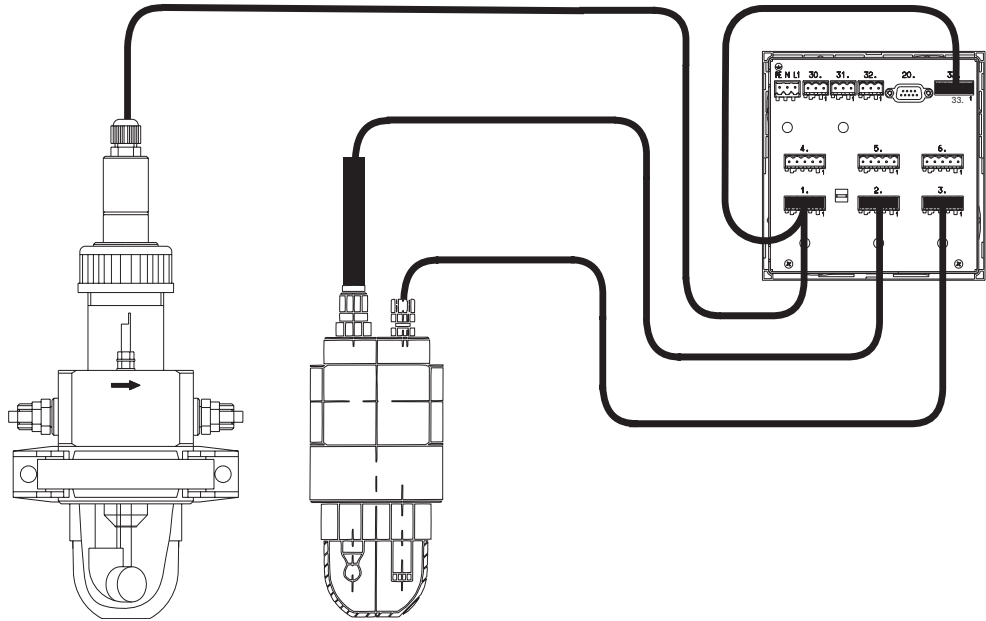

Terminal assignment, see Chapter 5.2 “Connection diagram”, Page 23.

5.8 Connecting other transmitters (0(4) – 20 mA current source)

Example: oxygen transmitter

Connection of the transmitter to channel 3.
Only operate a 2-wire transmitter from the internal power supply (terminal 33).

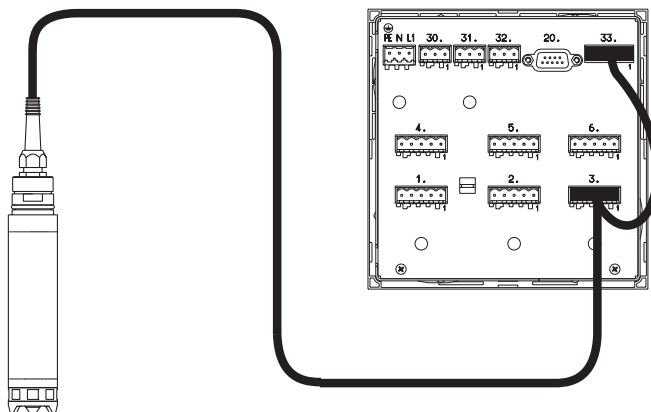

Terminal assignment, see Chapter 5.2 “Connection diagram”, Page 23.

6 Description

6.1 Displays and controls

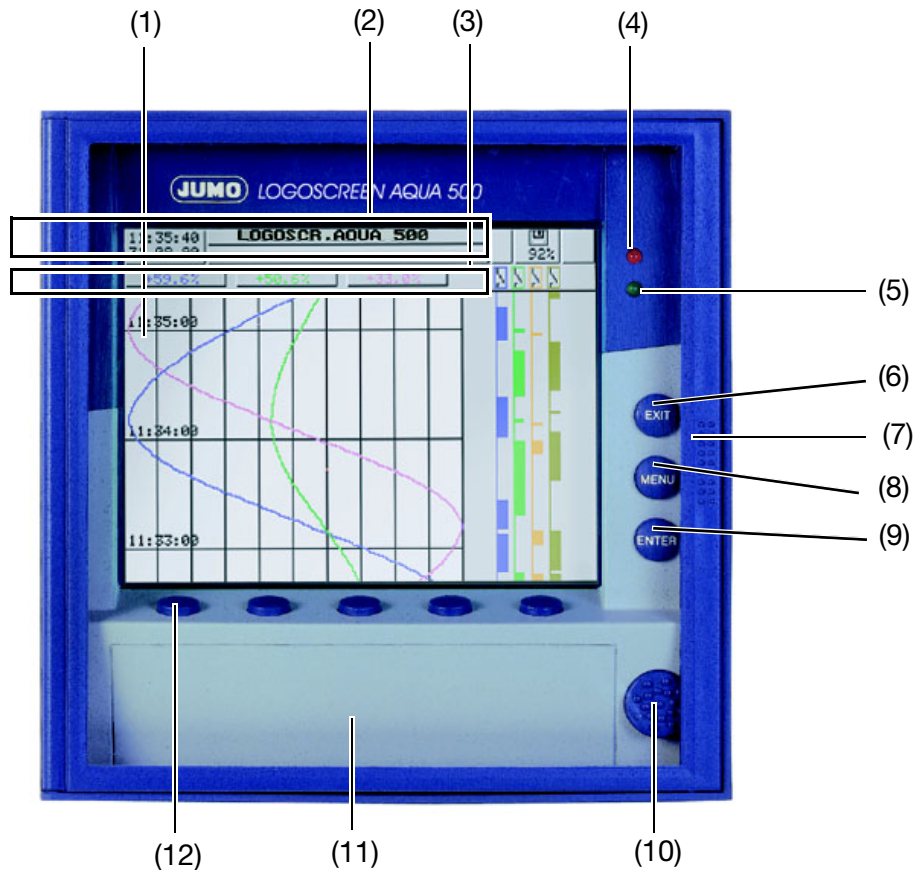

(1)	Color display 320 x 240 pixels, 27 colors	(7)	Rotary knob for opening the housing door
(2)	Header	(8)	Menu back to the basic menu ¹
(3)	Status line	(9)	Enter - select menu item - enter input
(4)	Status LED (red) is on continuously while an alarm is present	(10)	Release button for the disk drive cover
(5)	Power LED (green) is on continuously as soon as power is applied. Flashes when screen saving is active.	(11)	Cover for the disk drive
(6)	Exit previous window cancel current action	(12)	Menu-dependent function keys (softkeys) screen-dependent functions, represented by text or symbols

¹ Not from the configuration level if a parameter has already been modified there.



The life of the background lighting can be prolonged by using the screen saver.

see Chapter 8.5.1 “Parameterization”, Page 71.

6.2 Operating principle and graphic elements

Keys

The LOGOSCREEN AQUA 500 is operated from eight keys. Three of these have fixed functions (EXIT , MENU , ENTER). The other five keys (softkeys) below the screen have menu-dependent functions.

see Chapter 6.1 “Displays and controls”, Page 28.

Softkeys

The functions of the softkeys (1) appear in the bottom line of the display, as symbols or in plain text.

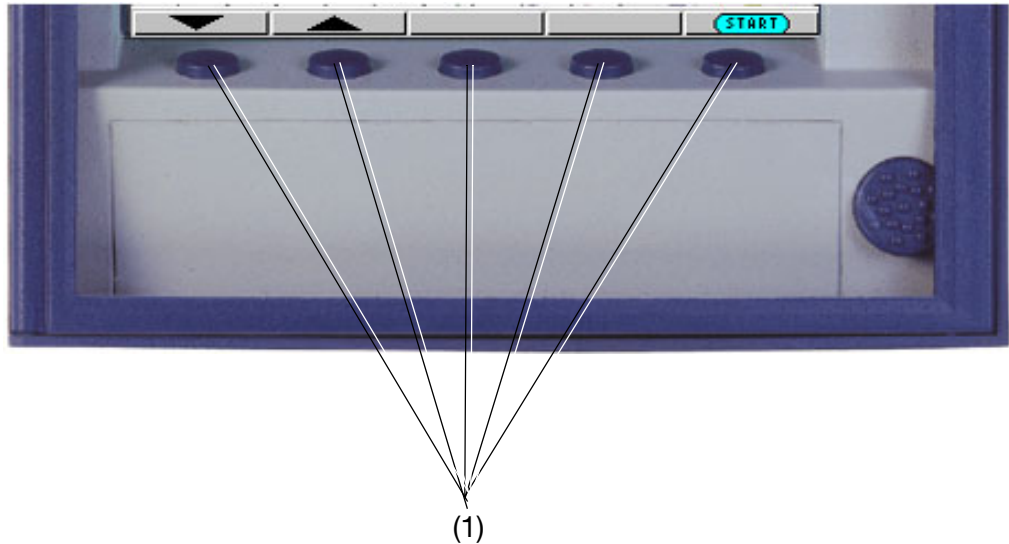





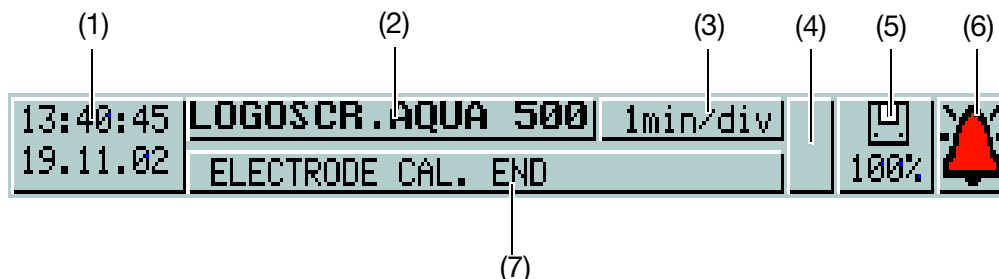

6 Description

Status line

The status line is shown in the top section of the display. It provides information on important actions and states.

The status line is always visible, irrespective of the level (operation, parameters, configuration).



(1)		Time & Date shows the current time and date
(2)		Instrument name (16 characters max.).
(3)		Speed display in “mm/h”, “time / division” or “storage rate”. (normal operation: gray, timed operation: turquoise, event operation: orange)
(4)		The egg timer appears whenever the instrument is busy and can therefore not be operated.
		The “H” informs you that the indicated measurements are derived from the past (history) The data saved in the FLASH memory are shown.
		In the event of an error, an “i” flashes here. The cause of the error can be read out from the instrument info window (see Chapter 7.8 “Instrument info”, Page 64)
		If the keys are inhibited, a key flashes in this position.
(5)		Diskette/internal memory Display of the available storage capacity. If there is a diskette error, the diskette symbol flashes. The error message can be checked in the disk manager. In the event of a “memory alarm”, the field is shown with a yellow background. see Chapter 7.7 “Disk manager”, Page 59
		available memory on diskette in percent
		available internal memory in percent
(6)		Alarm If an alarm occurs (e.g. out-of-limit), the (alarm) bell flashes in this field.
(7)		shows last entry in event list

6.3 Analog inputs

The LOGOSCREEN AQUA 500 can be equipped with 3 or 6 analog inputs. When configuring the analog inputs (see Chapter 8.5.3 “Configuration - Analog inputs”, Page 75), these are designated **Analog input 1 to 3 (1 to 6)** or channel 1 to 3 (1 to 6).



If the LOGOSCREEN AQUA 500 has been fitted with extra code 260 “Integrators and counters / math and logic module”, the result of the mathematical operation can be recorded on one analog input channel.

Then this specific analog input is **not** available for measurement tasks!

6.3.1 Representation of the analog signals

- Channel line (channel representation),
see Chapter 6.5.1 “Channel line (channel representation)”, Page 33.
 - Measurement display,
see Chapter 7.2.4 “Large digital display (large measurement)”, Page 48.
 - Diagram view,
see Chapter 7.2.1 “Diagram representation with digital display (small measurement)”, Page 46.
-

6.3.2 Use of the analog signals

- Integrators,
see Chapter 6.6.2 “Integrators”, Page 36.
 - Math module,
see Chapter 6.7 “Math / logic module”, Page 38.
-

6 Description

6.4 Digital inputs (extra code)

If the LOGOSCREEN AQUA 500 has been fitted with extra code 261, 4 logic inputs are available.

6.4.1 Representation of the digital signals

- Event traces,
see Chapter 7.2.1 “Diagram representation with digital display (small measurement)”, Page 46.
 - Event list (alarms, external texts, etc.),
see Chapter 7.6 “Event list”, Page 57.
 - Diagram view,
see Chapter 7.2.1 “Diagram representation with digital display (small measurement)”, Page 46.
-

6.4.2 Use of the digital signals

- Relay outputs
 - Event operation,
see Chapter 6.8 “Operating modes”, Page 41.
 - Event list (alarms, external texts, etc.),
see Chapter 7.6 “Event list”, Page 57.
 - Counters, operating time counters,
see Chapter 6.6 “Counters / integrators / oper. time counters (extra code)”,
Page 35.
 - Logic module,
see Chapter 6.7 “Math / logic module”, Page 38.
-

6.5 Representation

6.5.1 Channel line (channel representation)

The channel line shows the measurements of the active channels and their unit as

- measurement
- scaling or
- bar graph.

Alternatively, the header can be switched off altogether.

In addition, alarms and out-of-limit conditions are made directly visible, depending on the display mode.

The selection and visual presentation of the channel line can be controlled using the parameter “Channel representation”.

see Chapter 8.5.1 “Parameterization”, Page 71.

**Example:
Measurement
(small meas.)**

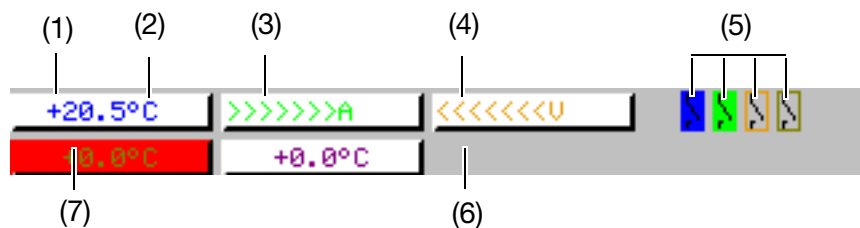

(1)	Numerical display The measurements are shown in numerical form.
(2)	Unit of measurement
(3)	Ovrange
(4)	Underrange
(5)	State of event traces
(6)	OFF If a channel has been switched off, then there will be no indication at all
(7)	Alarm If an alarm is present (e.g. out-of-limit), the measurement of the channel is shown on a red background

6 Description

6.5.2 Event traces

Signal types

In addition to the four logic inputs (extra code), digital signals generated by the instrument itself can also be displayed in the six event traces:

Signal	Description
Logic input 1 – 4	Four logic inputs present in hardware (extra code)
Logic channel 1 – 6	Channels which are created by using the math and logic module (extra code 260 required)
Low alarm 1 – 6	Underlimit of channels
Low combination alarm	OR linkage of all low alarms
High alarm 1 – 6	Overlimit of channels
High combination alarm	OR linkage of all high alarms
Counter/integrator alarm 1 – 6	Limit infringements of the counter and integrator channels (extra code 260 required)
Counter/integrator combination alarm	OR linkage of all counter/integrator alarms (extra code 260 required)
Combination alarm	OR linkage of all low and high alarms
Electrode calibration 1 – 6	Calibration of electrodes or measuring cells of channels
Electrode calibration	Within the “Service & Calibration” menu: indicates that an electrode or measuring cell calibration is taking or has taken place, or calibration values have been altered.
Memory alarm	Alarm is generated when the residual capacity of the diskette, or the available internal storage space falls below a certain value. see Chapter 7.7 “Disk manager”, Page 59.
Error	Alarm when the battery is empty, or the time has to be set. see Chapter 7.8 “Instrument info”, Page 64.
Modbus flag	Control flag which can be activated through the serial interface.

Representation

Representation on the screen is as follows:

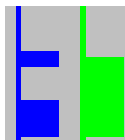
Representation	
as symbol	On/off represented as switch: 
as diagram	Representation as a record of time: 

Outputs	The digital signals can be used to operate three relays (extra code). The action can be configured as break (n.c.) or make (n.o.) contact, see Chapter 8.5.7 “Configuration - Outputs (extra code)”, Page 86.
External texts	“External texts” can be called up via four logic inputs (control signals). Either a standard text or one of the 18 definable texts can be used. The instrument automatically supplements the texts in order to distinguish between the appearance and disappearance of the signal. External texts are configured on the instrument. see Chapter 8.5.8 “Configuration - Control functions”, Page 87. see Chapter 7.6 “Event list”, Page 57.
Event operation	The digital signals can be used to activate event operation. In event operation, the measurements are stored at a storage rate which is different from normal operation.

6.6 Counters / integrators / oper. time counters (extra code)

Counters, integrators and operating time counters for up to six channels are available as an option.



They are **not** electrical measurement inputs (hardware), but channels which are calculated by the LOGOSCREEN AQUA 500 (software).

The results of the calculations are saved to the generated counter/ integrator channels.

6.6.1 Counters

Counter inputs	<ul style="list-style-type: none">- logic inputs- logic channels- electrode calibration signals- alarms- errors- Modbus flag (signal via serial interface)
-----------------------	---

6 Description

Counter frequency	30Hz max.
Weighting	The count pulses can be evaluated (weighted). A down counter can be implemented by entering a negative weighting (e.g. weighting factor -1). Each count change can be documented with an entry in the event list. The new count is attached to the message.

6.6.2 Integrators

Integrator inputs	Analog inputs 1 – 3 or 1 – 6
Integrator time base	sec, min, hr and day
Weighting	You can also enter a weighting for the integrators (see “Weighting” above).
Weighting example	<ul style="list-style-type: none">- measurement of flow volume- input signal 0 – 20mA (corresponds to 0 – 1000 liters/sec)- time base 1 sec- weighting 0.001- display of the integration value (volume) in m³
Minimum size of the input signal	Entering a threshold value (amount of the threshold value) has the effect that integration takes place only when the value has been exceeded. No integration will occur on falling below this value. The advantage of integration with a threshold value larger than 0 is that possible noise from a transducer can be suppressed in this way.

6.6.3 Operating time counter

The operating time counter will count how long a selected logic input or one of the digital signals is closed (set). The time can be displayed in sec, min, hr or days.

6.6.4 Reporting periods of the counts

After an adjustable time (reporting period), the counts are stored for all counters/integrators/operating time counters. The counts of the most recently concluded reporting period can be graphically displayed. The following counter/integrator types are possible:

- periodic
The time period (between 1 min and 12 hrs) must additionally be selected under the parameter "Period".
 - external
The counter/integrator is updated here only when the selected control signal is active (e.g. logic input is closed). When the control signal is deactivated (e.g. logic input is opened), the counter/integrator value is saved and reset to 0.
 - daily
 - weekly
 - monthly
 - yearly
 - total
 - daily from-to
The period also has to be selected, by means of the parameters "Daily start time" and "Daily end time". The counter/integrator will then be updated from the start time only. When the end time has been reached, the counter/integrator value is saved and reset to 0.
-

6.6.5 Resetting the counters / integrators / operating time counters

Periodic reset	<p>There is a reporting period for each counter/integrator/operating time counter. At the end of this period, the current data (value and time) are saved and the value reset to 0. Subsequently, the next period can be recorded.</p> <p>An exception is the totalizer/integrator. It is saved whenever any count/integration has been completed, but it is not reset to 0. It enables the totalizer to be evaluated also in the evaluation software PCA.</p>
External reset	<p>You can configure one control signal for all 6 counters/integrators together, with the result that the counters/integrators are reset to 0 without saving the previous values. The period for the counter/integrator summation will be restarted at this point. This means that after the test run of an installation, for instance, the recording can be freshly started; the test run values that are not required are eliminated.</p> <p>see Chapter 8.5.5 "Configuration - Counter/integrator (extra code)", Page 81.</p>
Reset from the keys	<p>Another option for resetting the counter/integrator values is provided at the parameter level. After entering the password, you can define a value for each of the 6 channels. The counter/integrator will then be set to this value. When, after editing, the value is entered, a message with the new and the old count is entered in the event list.</p> <p>The time period of the counter/integrator summation will not be freshly started. The previous counter/integrator values will also not be saved.</p>

6 Description



If you wish to save the previous counter/integrator values, you have to execute the function “Disk. update incl. counters ...” in the *Disk manager* menu before resetting.

In this way, you can also restart the recording of individual counters/integrators, for example after the test run of an installation; the values of the test run which are not required can thus be eliminated.

You can select a password other than that for accessing the configuration. The password can be set under:

see Chapter 8.5.2 “Configuration - Instrument data”, Page 73.

Reset via the *Disk manager* menu

If the function *Disk. update incl. counters* is executed in the “Disk manager” menu, the counts will also be saved and reset.

see Chapter 7.7 “Disk manager”, Page 59.

6.6.6 Response to instrument reconfiguration

When the instrument is reconfigured, the current counter/integrator reporting periods remain unaffected. The counter/integrator values will not be reset to 0 and the reporting period will not be restarted.



The values can be deliberately reset, via the *Parameterization* menu.

6.7 Math / logic module



In order to use the math/logic module, you will need the setup program (option) for entering formulae.

The instrument must be fitted with extra code 260 (integrator and counters...).

The math and logic module is optional (extra code).

see Chapter 2.1 “Type designation”, Page 12.

The math and logic module consists of 2 parts:

- the math module for calculating analog values and
 - the logic module for calculating Boolean values (0 or 1).
-

Math module

There are no separate math channels for the calculated channels, the existing analog channels 1 – 3 are 1 – 6 are used instead. In configuration, you have to select the “Math” option under the parameter “Sensor” for the required channel.

see Chapter 8.5.3 “Configuration - Analog inputs”, Page 75.

Each of the three or six channels can either be used for recording the corresponding measurement input or as a math channel.

Example:	AE:	Value
	AE1:	Pt 100, 0 – 150°C
	AE2:	Pt 100, 0 – 50°C
	AE3:	Math AE1 + AE2
	AE4:	Math AE1 - Ae2
	AE5:	Math SQRT(AE1 +AE2)
	AE6:	not used

When the measurement inputs AE1 and AE2 are mathematically linked, the measurement inputs AE3 to AE5 in the example above are not available as sensor inputs.

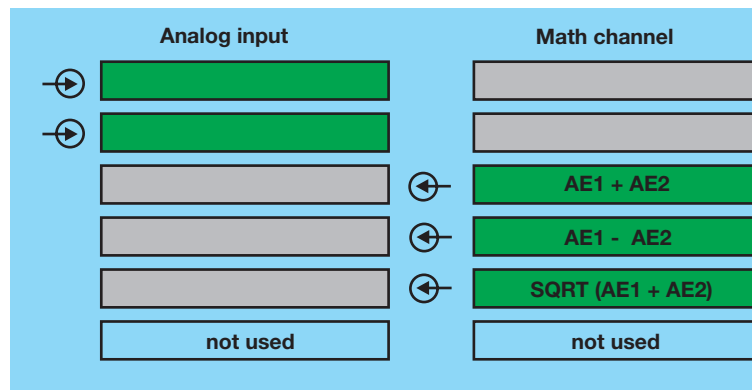

The channel number of a math channel indicates which analog input is being used by the math channel.

Variables

The following variables are used for the formulae:

- analog inputs (AE1 – AE6)
- counter/integrator channels (ZI1 – ZI6)
- logic inputs (BE1 – BE4)
- alarms
- errors
- Modbus flag (signal via serial interface)
- instrument-specific data (only after consultation with the manufacturer)

If counter/integrator values are used for calculation in the math module, their accuracy is reduced, since, in this case, two different data formats have to be used for calculation. The counters/integrators are calculated in the double-float format, whereas the math module employs a single-float format according to the IEEE 754 standard. However, in spite of the different formats, the math module can work with these values.

6 Description

The following fixed functions are available:

- difference
- ratio
- relative humidity
- moving average

For the moving average, the reference channel has to be entered (in most cases, the analog input no.) and the time (in minutes) which is to be used to calculate the moving average.

The following operators and functions are available for the formulae:

+, -, *, /, (,), SQRT(), MIN(), MAX(), SIN(), COS(), TAN(), **, EXP(), ABS(), INT(), FRC(), LOG(), LN().

On going above or falling below the scalable values, the math channel is treated as for “out-of-range”.

The formulae are entered in the PC, in the setup program. The mathematical formulae cannot be edited on the instrument by using the keys.



Additional information:
see Chapter 12.5 “Math and logic module”, Page 159.

Logic module

A maximum of six logic channels are available.

As is the case with all the other digital signals, the calculated digital (Boolean) values can be used for different functions:

- recording in the event traces,
- as a control signal for display switch-off,
- clock time synchronization,
- operating time counter,
- externally controlled counters / integrators
- counter/integr. reset
- event operation and key inhibit,
- for output to a relay and
- as count input for a counter.

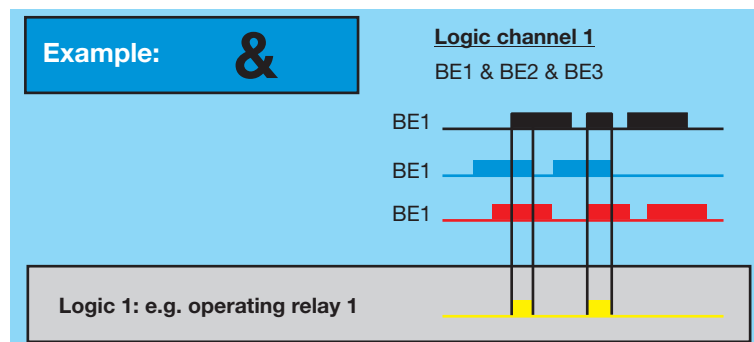

The following variables are used for the formulae:

- logic inputs
- logic channels
- alarms
- electrode calibration signals
- errors
- Modbus flag (signal via serial interface)
- TRUE
- FALSE
- instrument-specific data (only after consultation with the manufacturer)

These functions can be used for the formulae:

- !(NOT)
- &(AND)
- |(OR)
- ^(XOR)
- /(rising edge)
- \ (falling edge)
- ((open bracket)
-) (close bracket)



Additional information:
see Chapter 12.5 “Math and logic module”, Page 159

6.8 Operating modes

Three operating modes

- normal operation
- timed operation
- event operation

The following settings can, among others, be made for each of the three operating modes:

- stored value
- storage rate

Stored value

The stored value determines whether the average/minimum/maximum or instantaneous value of the time interval between two storage cycles or the peak values (envelope) are stored. When “peak value” is set, then the minimum and maximum values of the last storage cycle are stored.

Storage rate

The storage rate determines the interval between two stored values. The diagram speed corresponds to the storage rate, which means that with a storage rate of 5sec, the stored value is entered in the diagram every 5sec.

6 Description

Normal operation

Normal operation is active whenever event or timed operation is not active.

Timed operation

For timed operation, a period of time can be defined (up to 24 hrs) within which a specific stored value and a specific storage rate are active.

Event operation

Event operation is active as long as its control signal is active (see Chapter 8.5.6 “Configuration - Measurement storage”, Page 85). Event operation can be used, for example, to shorten the storage cycle when an alarm is present.

Priority

The respective priorities of the operating modes are allocated as follows:

Operating mode	Priority
Normal operation	low
Timed operation	average
Event operation	high

Active operating mode

The active operating mode is shown in the diagram by the background color for the diagram speed:

Operating mode	Color
Normal operation	gray
Timed operation	turquoise
Event operation	orange



Additional information:
see Chapter 6.2 “Operating principle and graphic elements”, Page 29.

6.9 Data storage

Recording capacity

- internal memory: approx. 350,000 measurements
(with option “Memory expansion to 2MB“: approx. 850,000 measurements)
- diskette: approx. 650,000 measurements

The recording capacity is reduced when many event messages are also stored.

Storage rate

Different storage rates, ranging from 1 sec to 32767sec can be configured for normal, event and timed operation under “configuration”.

The storage rate determines the time intervals at which the measurements are stored.

6 Description

Stored value Under this parameter, the value to be stored (average, instantaneous, maximum or peak value) is configured separately for normal, event and timed operation.

Recording format Data are recorded encoded in a proprietary format.

Recording duration The recording duration depends on various factors:

- number of analog channels and event traces being recorded
- storage rate
- number of events in the event list



The setup program calculates the recording duration for the current configuration.

Optimization of recording duration The recording duration can be optimized by process-oriented selection of the storage rate.

In normal operation (no error, no alarm, ...) a storage interval that is as long as possible (e.g. 60sec, 180sec, ...) should be selected, depending on the particular application.

In the event of an alarm or error, the storage rate can be shortened via event operation, with the effect that the measurement data are recorded with a high time resolution.

Start logo After starting up the LOGOSCREEN AQUA 500 by switching on the supply (power ON), the start logo (company logo) appears.



During screen build-up, the instrument is initialized with the data of the last configuration.



After the initialization phase, the measurement diagram (visualization level) is displayed.

7 Operation

7.1 Basic menu

The basic menu is the central point from which the various instrument levels branch out.

The following levels are available:

- Visualization
- Service & calibration
- Parameterization
- Configuration
- Event list
- Disk manager
- Instrument info

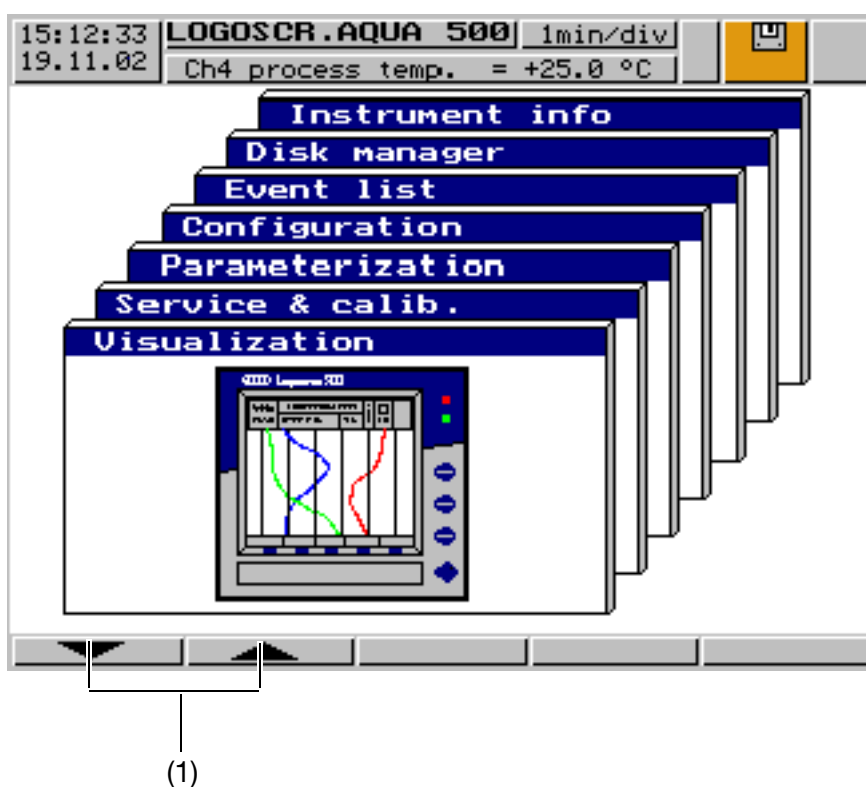

(1)	Scroll in menu (forwards / backwards)
-----	---------------------------------------

- * Select the required level
- * Confirm selection with , see Menu structure



The basic menu is displayed after pressing the ¹ key.

¹ Not from the configuration level if a parameter has already been modified there.

7.2 Visualization

The function keys (softkeys) at the bottom of the screen change their function according to the menu and are shown as symbols or in plain text.

see Chapter 6.2 “Operating principle and graphic elements”, Page 29.

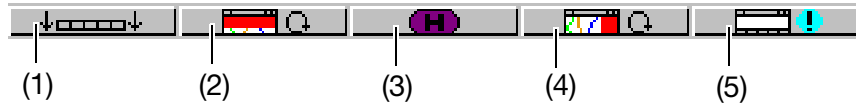

(1)	Hide function keys (softkeys) ¹
(2)	Alter channel representation (header) <ul style="list-style-type: none"> - diagram representation with digital display (small measurement) - diagram representation with scaling - diagram representation with bar graph - large digital display (large measurement) - curve representation (header switched off)
(3)	Evaluation of stored measurement data (history)
(4)	Alter signal type (show or hide representation / event traces) <ul style="list-style-type: none"> - analog input without event traces - analog input and event traces
(5)	Show event list

¹ The symbols for the function are shown again by pressing any softkey.

The LOGOSCREEN AQUA 500 can optionally be equipped with “Counters/ integrators“ as an extra. In this case, the symbol for indicating the counts will appear below the softkey on the right, the symbol for showing the event list is shifted to the counter display.



(1)	Show counters / integrators / operating time counters
-----	---



7 Operation

7.2.1 Diagram representation with digital display (small measurement)

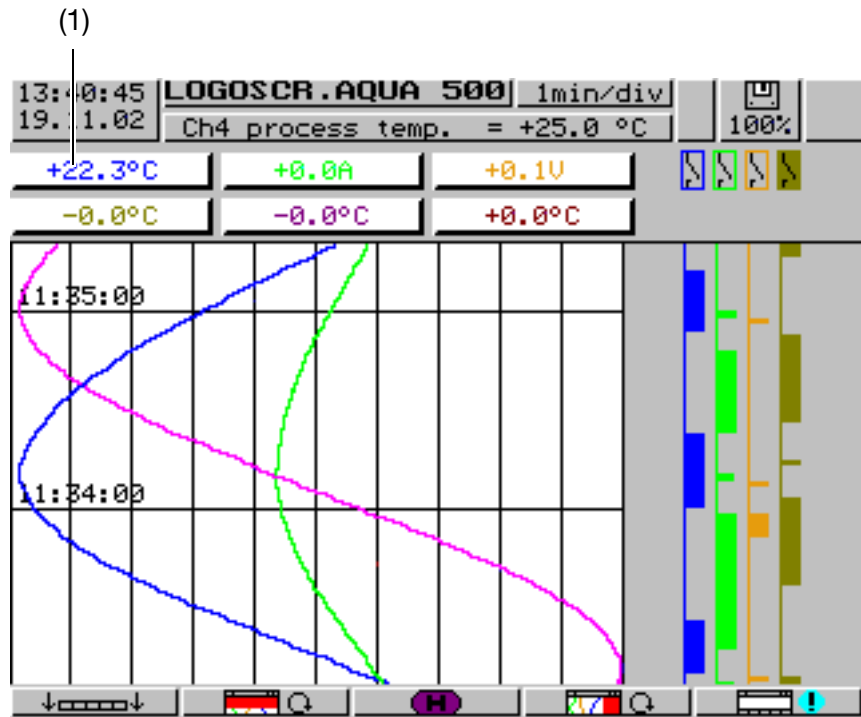
Diagram representation can be reached from the basic menu, by calling up the *Visualization* menu, or by pressing the **EXIT** key.



- | | |
|-----|---|
| (1) | <ul style="list-style-type: none">- current measurements of the analog inputs including dim. unit- measurement on a red background ⇒ overlimit |
|-----|---|

By using the parameter *Parameterization* → *Diagram view* → *Signal type* (or the  button), it is possible to select whether, in addition to the analog channels, also the event traces are to be displayed. The contents of the header is determined by means of the parameter *Parameterization* → *Diagram view* → *Channel representation* (or the  button).

7.2.2 Diagram representation with scaling

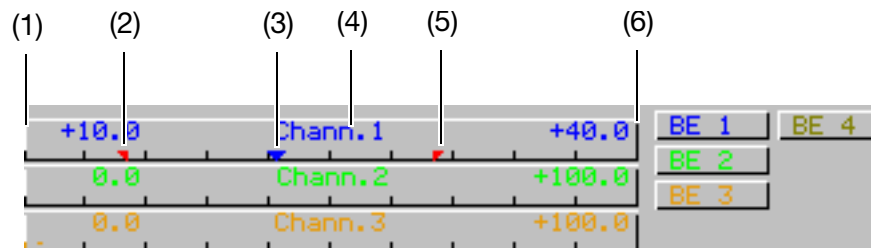

(1)	Scaling start of the selected channel
(2)	Lower limit marker of selected channel (no display when alarm is off)
(3)	Current measurement
(4)	Channel designation
(5)	Upper limit marker (no display when alarm is off)
(6)	Scaling end of the selected channel

Which scaling (on which channel) is to be displayed can be selected through the parameter *Parameterization* → *Diagram view* → *Channel indication*.

7.2.3 Diagram representation with bar graph

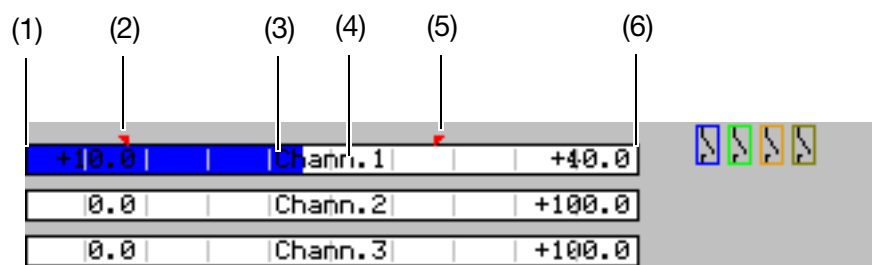

(1)	Scaling start of the selected channel
(2)	Lower limit marker of selected channel (no display when alarm is off)
(3)	Current measurement
(4)	Channel name
(5)	Upper limit marker (no display when alarm is off)
(6)	Scaling end of the selected channel

Which bar graph (on which channel) is to be displayed can be selected through the parameter *Parameterization* → *Diagram view* → *Channel indication*.

7 Operation

7.2.4 Large digital display (large measurement)

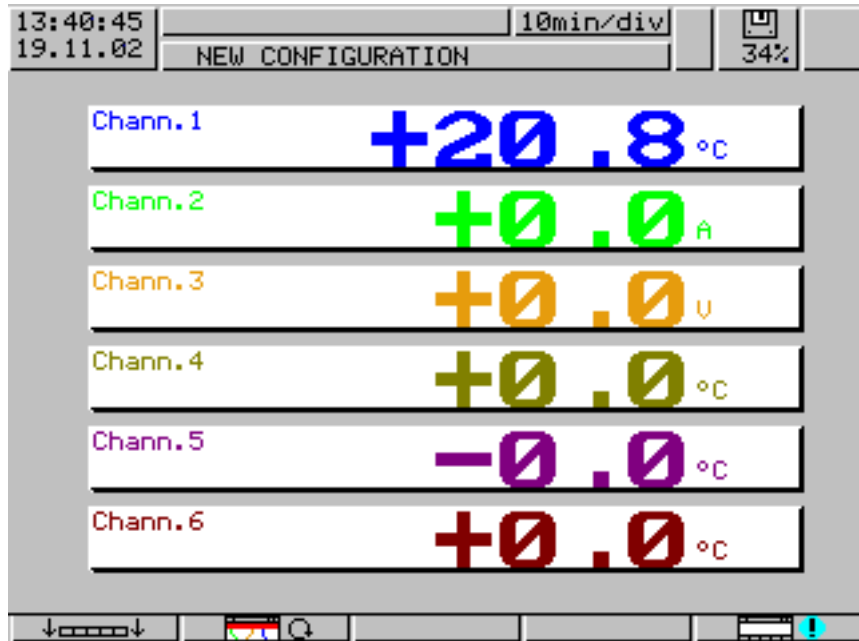

This display type is limited to the digital display of the measurements.

7.2.5 Curve representation (header switched off)

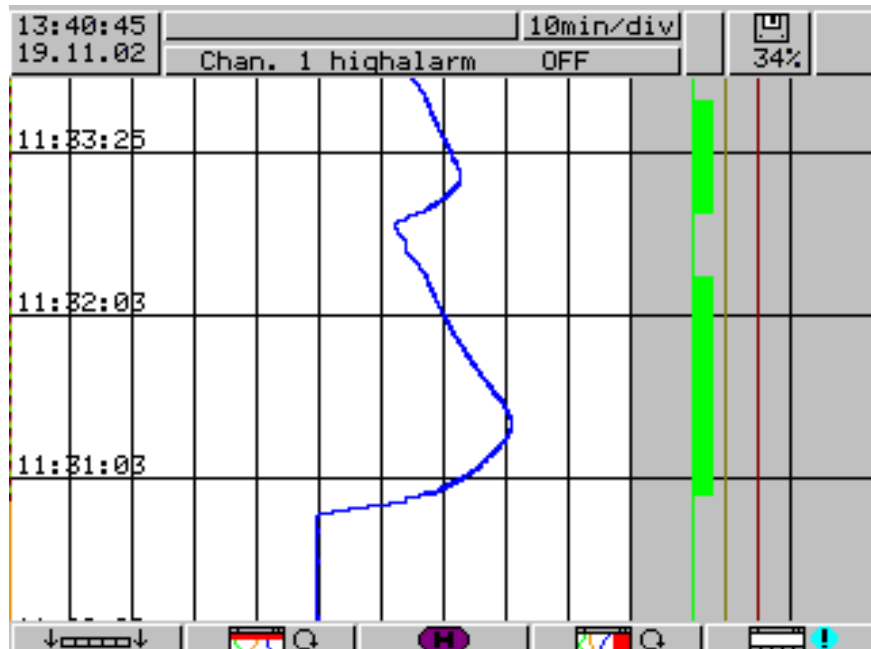

This display type is limited to the representation of measurements and, if required, event traces as curves

7.2.6 Evaluation of the stored measurement data

History

The softkey function changes during evaluation and, in addition, the current zoom factor and cursor position (date and time)

Scroll operation

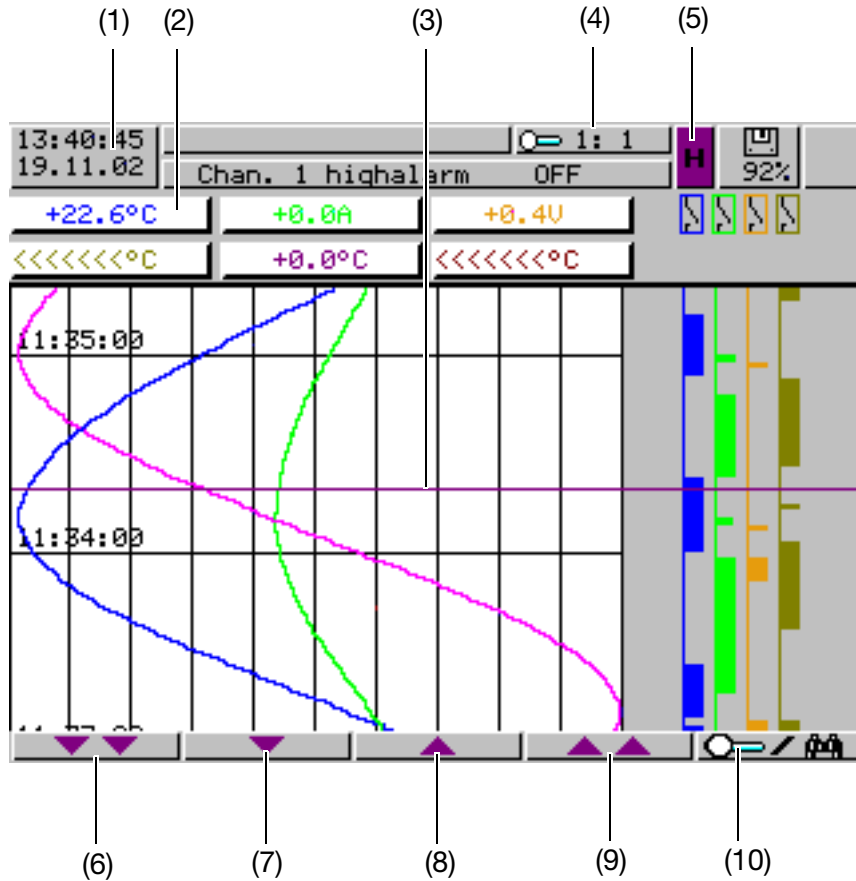

(1)	Date and time of measurements at the cursor position	(6)	Scroll backwards fast (one screen)
(2)	Measurement at the cursor position	(7)	Scroll backwards slowly (one pixel line)
(3)	Cursor (violet)	(8)	Scroll forwards slowly (one pixel line)
(4)	Current zoom (magnification)	(9)	Scroll forwards fast (one screen)
(5)	History activated	(10)	Switch to softkey functions Zoom/Search

Using these softkeys, the measurement data display can be scrolled (shifted) on the screen within the measurement data stored in the internal memory.



Measurement acquisition remains active during history representation.

7 Operation

Zoom

If the zoom factor has to be adjusted, or specific times have to be searched, then it is necessary to switch the softkey functions.

* Press the  softkey

The degree of compression of the measurement data on the screen is given as a ratio in steps (1:1, 1:2, 1:5, 1:10, 1:20, 1:50 and 1:100).

For instance, 1:100 means that 1 screen pixel corresponds to 100 measurements, which means that only every hundredth stored measurement is displayed.

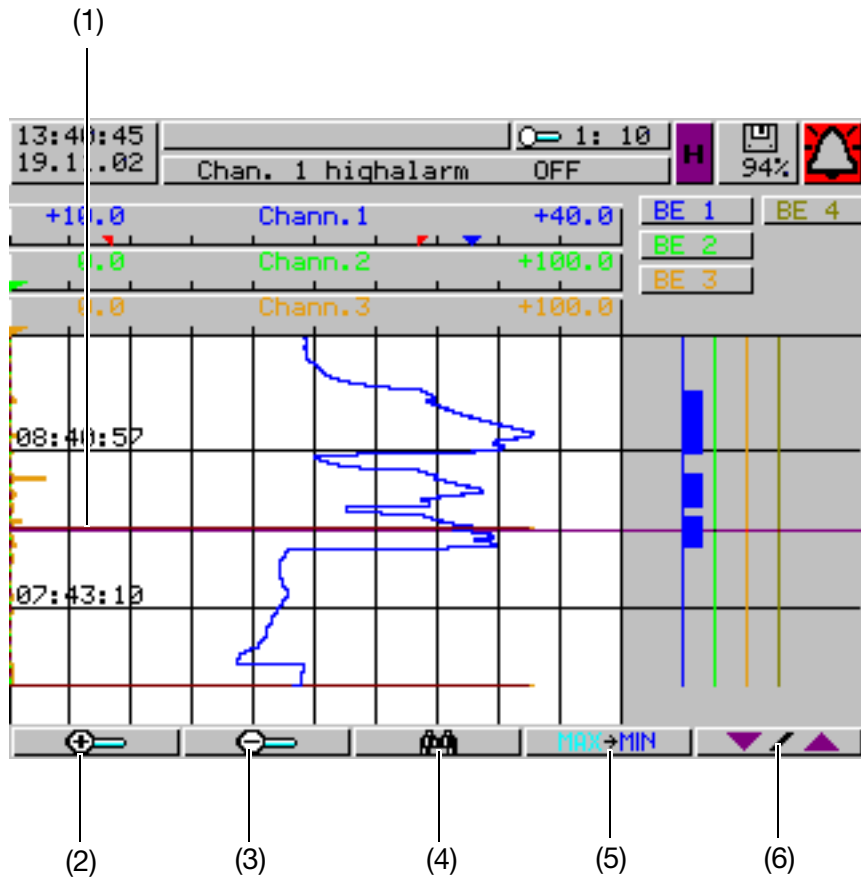

(1)	Cursor (violet)	(4)	Position cursor on time (selectable)
(2)	Zoom +	(5)	Only for peak value acquisition: switch channel line between min. and max display
(3)	Zoom -	(6)	Switch to softkey function "Scroll"

Positioning the cursor



- * Press this key for positioning the cursor on a specific time.

The following dialog appears:

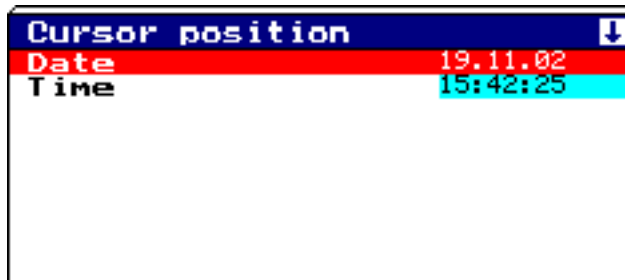

- * Enter date and time, then press .





The cursor is positioned on the selected time.

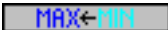

If no measurement data have been stored for the selected time, then the cursor is positioned on the next possible time.

Peak value acquisition

If the data have been recorded in the “peak value” mode, then two different measurements (one minimum and one maximum value) may be displayed graphically for one instant of time (storage cycle). Using the  key, it is possible to switch between minimum and maximum value display within the “measurement” display mode.

	Function key	Channel line
Minimum		
Maximum		

Peak value acquisition is programmed (activated) by the parameters:

- Configuration → Measurement storage → Normal display → Stored value
- Configuration → Measurement storage → Event operation → Stored value
- Configuration → Measurement storage → Timed operation → Stored value

Further information about the “measurement” display mode:

see Chapter 7.2.1 “Diagram representation with digital display (small measurement)”, Page 46.

and

see Chapter 7.2.4 “Large digital display (large measurement)”, Page 48.

7 Operation

7.2.7 Counters / integrators / operating time



Count display is optional (extra code).

* Press softkey

The display below (example) shows the current counts in numerical form.

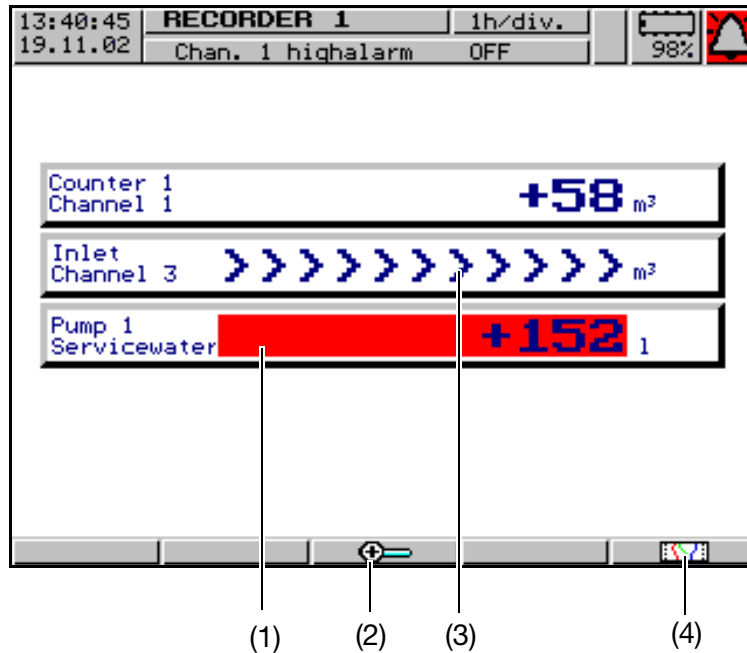

(1)	Programmed alarm limit exceeded
(2)	Expanded representation
(3)	Overrange
(4)	Show curves

Expanded representation



* Press softkey

You will see the following display (example):

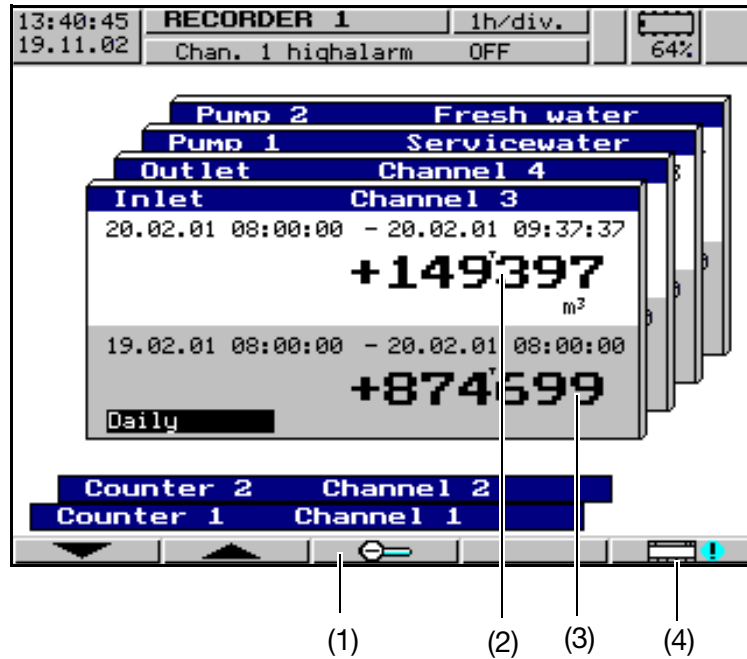

(1)	Normal representation
(2)	Current count
(3)	Concluded reporting period
(4)	Event list see Chapter 7.6 “Event list”, Page 57.

7.3 Service & calibration

see Chapter 10 “Service & calibration”, Page 112.

7 Operation



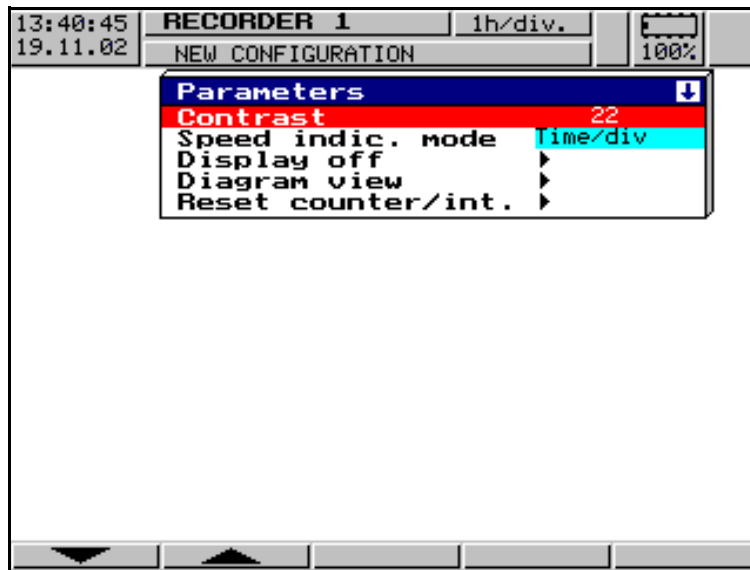

7.4 Parameterization



The “Parameterization” level is available to set

- contrast,
- speed indication
- display off
- diagram view and
- counter/integrator reset



All parameters are selected using the  and  or  and  keys.

Contrast

The contrast of the screen can be set here. This ensures that the screen is always highly legible, even under difficult light conditions.

Speed indication

“mm/h”, “time/div” or “storage rate” is selected here for the speed display in the diagram.

Example: a diagram speed of 1 h/div correspond to approx. 22mm/h.

Display off

Switch-off event = waiting time

For screen saving, a time between 0 and 32767min can be set under the parameter “Waiting time”. If no key on the LOGOSCREEN AQUA 500 is operated during this time, then the screen goes dark. The power LED blinks during screen saving.

If 0 min is set, then screen saving is deactivated.

Switch-off event = control signal

In this case, screen saving is performed using one logic input (extra code). The logic input is selected via the parameter “Control signal”.

Screen saving is deactivated when "Off" is selected.

Diagram view

Diagram view → Signal type

The representation mode of the measurements and event traces are determined here:

- analog inputs
- analog inputs and event traces

Diagram view → Channel representation

The contents of the channel bar is selected here:

- small measurement
- scaling
- bar graph
- large measurement
- off

Diagram view → Channel indication

The channels which are displayed in the channel line, in the representation mode "Scaling" and "Bar graph", are selected here.

Diagram view → Paper perforations

Can only be selected if the analog channels only and **no** event traces are displayed. When yes is set, paper perforations appear in the diagram, thus giving the picture the appearance of a conventional chart recorder.

Counter/ integrator reset

After the password has been successfully entered, the counts for each of the 6 channels can be set to 0 or a defined value in this menu.

When a value has been entered (confirm with ) , a message with the new and the old count is entered in the event list. The time period for the counter/integrator summation will not be restarted. The recent counter/integrator values will not be stored.

If you wish to do so, you have to execute the *Update diskette incl. counters* function in the *Disk manager* menu before resetting. In this way, the recording of the counters/integrators can be restarted, for example after the test run of an installation; the test run values, which are not required, can thus be eliminated.

You can select a password that is different from that for accessing the configuration. The default value is also 9200.

The password can be set in the menu *Configuration → Instrument data → Code No. (Password) → Reset counter/int.*

7 Operation

7.5 Configuration

When you call up the configuration level, the password is requested (factory setting 9200). This also serves to prevent any unauthorized alteration of the configuration.

see Chapter 7.10 "Code number (password query)", Page 67.



The data saved to diskette and the FLASH memory are deleted when the configuration is altered. Save data, if necessary!
see Chapter 7.7 "Disk manager", Page 59.

Window technology

As for the other levels, the principle of configuration is also based on menu-led window technology. Individual menu items can be selected in the windows. The window title describes the contents of the window.

If a menu item is selected, a further window is opened with new menu items, until the required parameter is finally reached. If several windows are open, the window title assists in orientation.

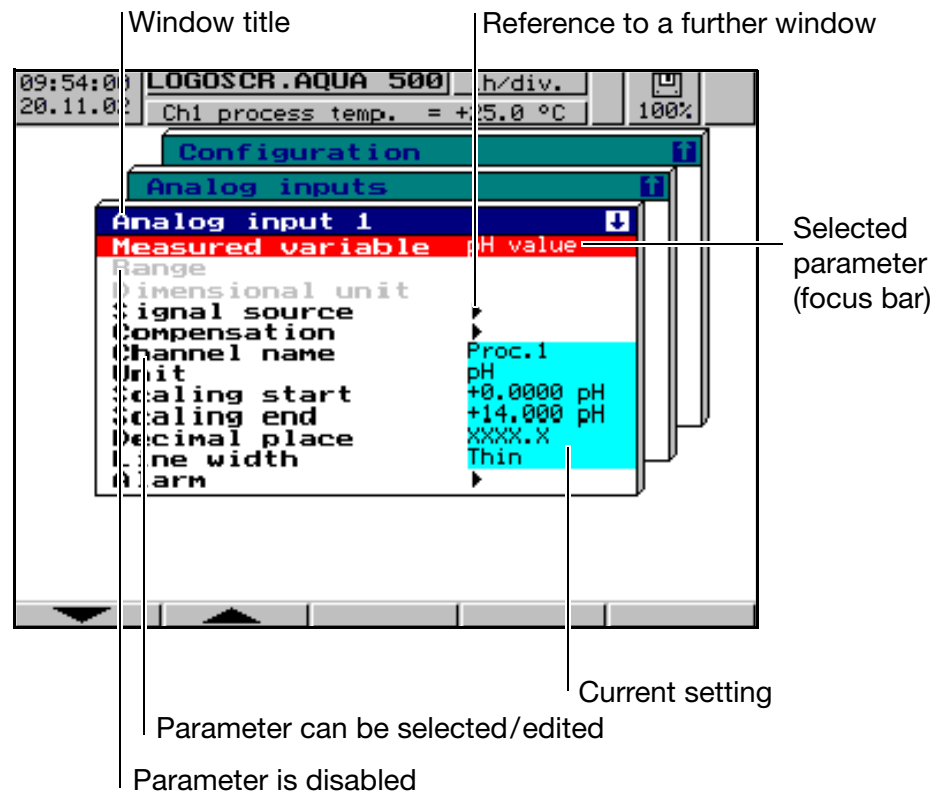

The configuration of the LOGOSCREEN AQUA 500 is sub-divided into the following levels:

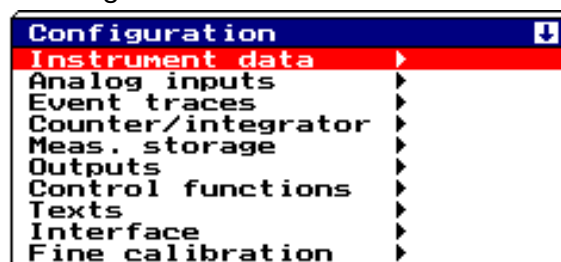

7.6 Event list

Basic menu →
Event list

The event list is called up via the basic menu:

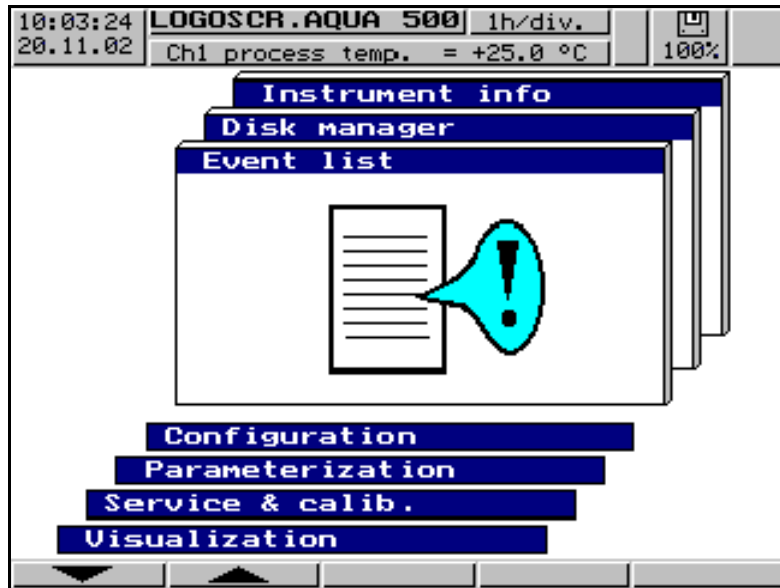

- * Select *Event list* level
- * Confirm selection with ENTER

Event list

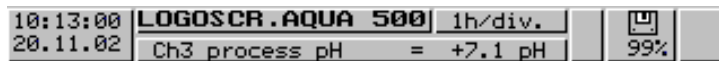

Event list			
06.08.02	07:26:36	Ch3 process pH	= +7.1 pH
06.08.02	07:25:07	Chan. 1 low alarm	OFF
06.08.02	07:23:37	Alarm counter/int1	OFF
06.08.02	07:23:36	COUNTER/IN.1 FR.	+4
		RESET TO	+0
06.08.02	07:23:06	ELECTRODE CAL. END	
06.08.02	07:22:23	Alarm counter/int1	ON
06.08.02	07:22:22	Calibr.Chlorine cell	+4
06.08.02	07:22:22	Ch3 electrode calib.	ON
06.08.02	07:21:44	Ch3 process pH	= +6.9 pH
06.08.02	07:21:08	Chan. 1 low alarm	ON
06.08.02	07:20:33	ELECTRODE CAL. END	
06.08.02	07:19:34	Ch1 electrode calib.	ON
06.08.02	07:18:29	Calibr.Chlorine cell	+3
06.08.02	07:18:29	Ch3 electrode calib.	ON
06.08.02	07:17:58	Ch1 process temp.	= +26.0 °C

jump back directly into diagram presentation

7 Operation

Events

Various events can initiate texts which are incorporated in the event list and saved to the internal memory or diskette. Events may include:

- alarms triggered by out-of-limit conditions on individual channels,
- external texts triggered through logic inputs,
- system messages (e.g. power ON/OFF, summer/winter time changeover),

Standard texts

The instrument offers standard texts as listed in the following table:

Standard text	Comments
Chan. <i>a</i> low alarm ON Chan. <i>a</i> low alarm OFF Chan. <i>a</i> high alarm ON Chan. <i>a</i> high alarm OFF Alarm counter/int <i>b</i> ON Alarm counter/int <i>b</i> OFF Logic input <i>c</i> ON Logic input <i>c</i> OFF Logic channel <i>d</i> ON Logic channel <i>d</i> OFF	<i>a</i> = channel number <i>b</i> = counter/int. channel number <i>c</i> = input number <i>d</i> = logic channel number <i>e</i> = counter value (9 digits) <i>f</i> = old counter/int. value (9 digits) <i>g</i> = new counter/int. value (9 digits) <i>h</i> = new process temperature <i>i</i> = new process pH value
Counter <i>b</i> : <i>e</i>	
Power ON Power OFF Data lost Summer time start Summer time end New configuration Counter/in. <i>b</i> fr. <i>f</i> reset to <i>g</i> Cha process temp. = <i>h</i> Cha process pH = <i>i</i> Cha electrode calib. ON ELECTRODE CAL. END	
"Text 1 – 18"	18 freely definable texts with 20 characters each

Supplementary text



The instrument automatically supplements the texts by "ON" or "OFF" in order to distinguish between the appearance and disappearance of the signal.

Example:

Standard text	Supplementary text	Entry in event list
Logic input 2	ON	Logic input 2 ON
Logic input 2	OFF	Logic input 2 OFF

Event definition	For all events, except for system messages, it is possible to configure whether: <ul style="list-style-type: none">- the message text is to be included in the event list,- the instrument-internal standard text- or one of the texts (see below) is used.
Text assignment	The texts (standard texts or 18 freely definable texts) are assigned to events at the operation level see Chapter 8.5.8 "Configuration - Control functions", Page 87.
Freely definable texts	18 texts can be freely defined, up to a length of 20 characters.

7.7 Disk manager

Automatic storage of measurement data	<p>The data stored in the measurement data memory (FLASH) of the LOGOSCREEN AQUA 500 are saved at regular intervals to the diskette in the instrument.</p> <p>The PC evaluation program (PCA), see Chapter 13 "PC evaluation program", Page 165, reads the data from the diskette and provides functions for evaluation.</p> <p> The data saved to diskette and the FLASH memory are deleted when the configuration is changed.</p>
Loading and saving the configuration data	<p>The configuration data can be downloaded from and saved to diskette. A configuration can thus be copied from one instrument to another, or it can be transferred from and to the PC setup program.</p> <p> Caution: When the instrument is reconfigured:</p> <ul style="list-style-type: none">- all data will be deleted!- the calibration parameters and calibration values will be reset to the default values!- the logbooks are deleted and initialized with the default values (preset)! <p>The data can be backed up on diskette beforehand, by using the disk manager</p> <p>.</p>

7 Operation



Tip:

The calibration values and logbooks can be retained, if minor changes **that do not relate to the analog inputs** and their electrodes or measuring cells are made in the configuration **from the instrument keys**.

Minor changes are, for example: setting the time, alteration of code numbers, changes to the text.

**Basic menu →
Disk manager**

The disk manager is called up via the basic menu:

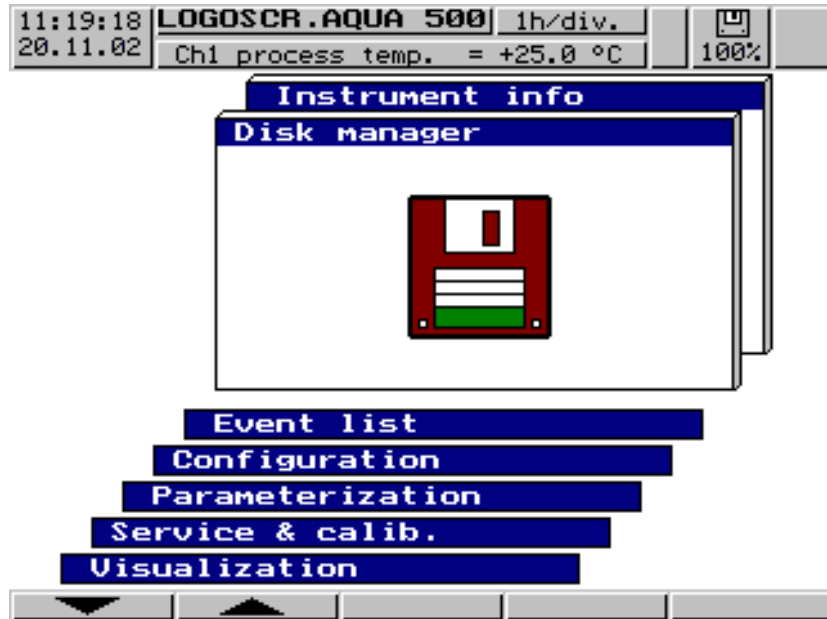

- * Select operating level *Disk manager*
- * Confirm selection with ENTER

The functions

- *Disk. update incl. counter ...*,
- *Compl. meas. data → disk.*,
- *Config. data → diskette* and
- *Diskette → Config. data*

are protected against unauthorized access by a password query (factory setting: 9200).

Disk manager

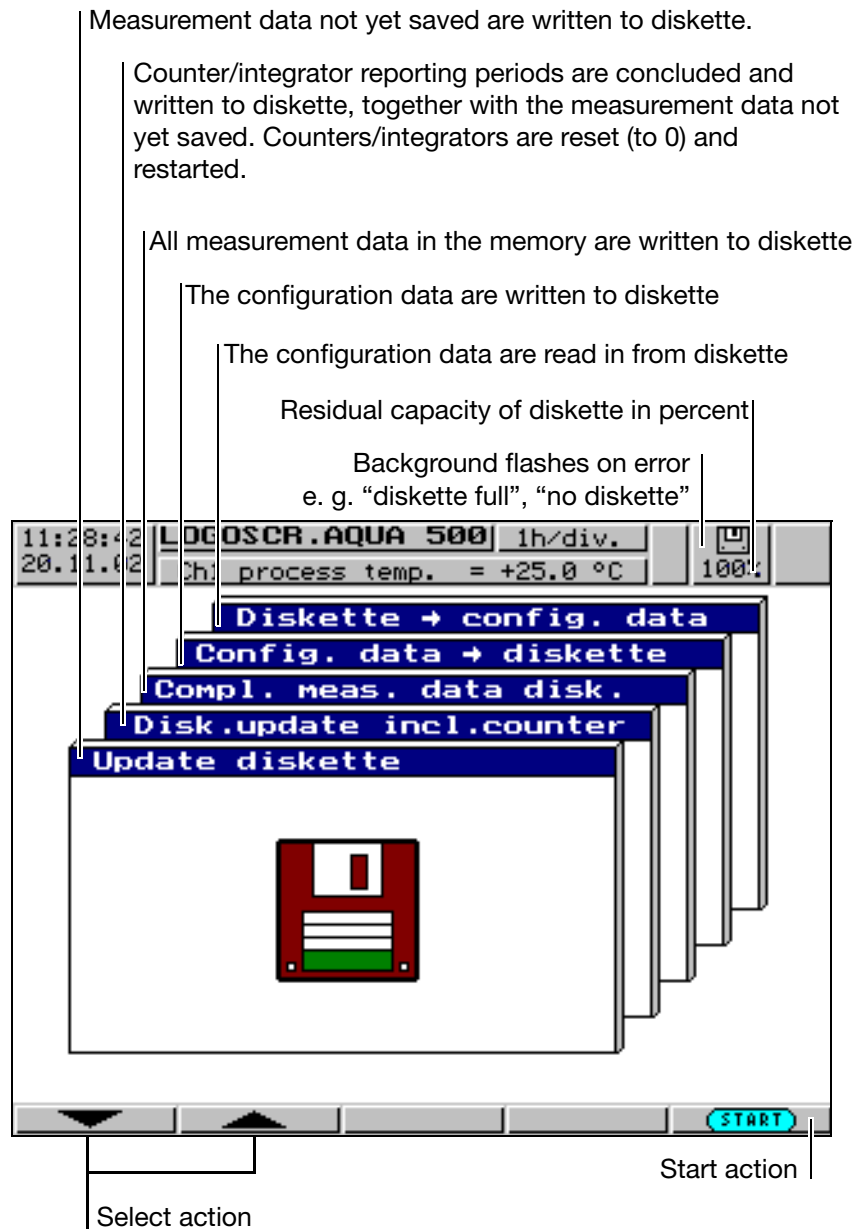

The function "Compl. meas. data → disk." serves to salvage data when the original diskette is no longer available.

Memory alarm

At the configuration level, a percentage (residual capacity of diskette) can be specified under *Instrument data* → *Memory alarm*. When the residual capacity of the inserted diskette reaches this percentage, the "Memory alarm" signal is activated. It can, for instance, be used to operate a relay or switch over to event operation.

see Chapter 6.9 "Data storage", Page 42.

see Chapter 6.5.2 "Event traces", Page 34.

see Chapter 8 "Configuration parameters", Page 69

7 Operation

Status messages

Status messages of the disk manager are shown in the corresponding action window. The following status messages are possible:

Status message	Description
DISKETTE UPDATED	Directly before removing the diskette from the instrument, it is necessary to call up <i>Update diskette</i> so that all measurement data up to the time of removal are contained on the diskette. The data not yet saved since the last automatic save are written to diskette.
DISKETTE NOT UPDATED	An error has occurred during updating. This message may have several causes. Remedy: repeat procedure
INITIALIZING DISKETTE	The instrument detects the insertion of a new or foreign diskette.  New or foreign diskettes are overwritten without a security query.
NO DISKETTE	If there is no diskette in the instrument, the diskette symbol flashes in the status line.
DISKETTE WRITEPROTECTED	The inserted diskette cannot be written to because it is write protected. Remedy: Remove write protection.
DISKETTE FAULTY	An error has occurred while writing to diskette. The diskette is faulty. Remedy: Insert new (DOS-formatted) diskette.
DISKETTE FULL	When the diskette is full, the diskette symbol flashes in the status line. No more data are written to diskette. Remedy: Insert a blank diskette before the measurement data memory of the LOGOSCREEN AQUA 500 is also full. If this is not done, measurement data will be lost.
PROGRAM DISKETTE	The message appears when a program diskette is inserted in the disk drive and measurement data have to be written. Remedy: Insert the correct diskette, or a blank one.

7 Operation

Status message	Description
CONFIG-DISKETTE	This message appears when a configuration diskette is inserted in the disk drive and measurement data have to be written. Remedy: Insert the correct diskette, or a blank one.
GOLDCAP WAS EMPTY	This message appears when a capacitor is built into the LOGOSCREEN AQUA 500 for memory buffering and the instrument has remained switched off for such a long time that the capacitor has become discharged. Caution: This will falsify the measurement data.
WRONG VERSION NUMBER !	An attempt was made to read in a configuration from diskette but the version numbers of the instrument software and configuration are different. Remedy: Convert configuration diskette via the PC setup program and create a new one.

7 Operation

7.8 Instrument info



The instrument info window displays general information about the instrument. It also includes the errors “Battery empty” and “Data lost”. If one of the instrument errors occur, the info symbol flashes in the status line.

**Basic menu →
Instrument info**

The instrument info is called up from the basic menu:

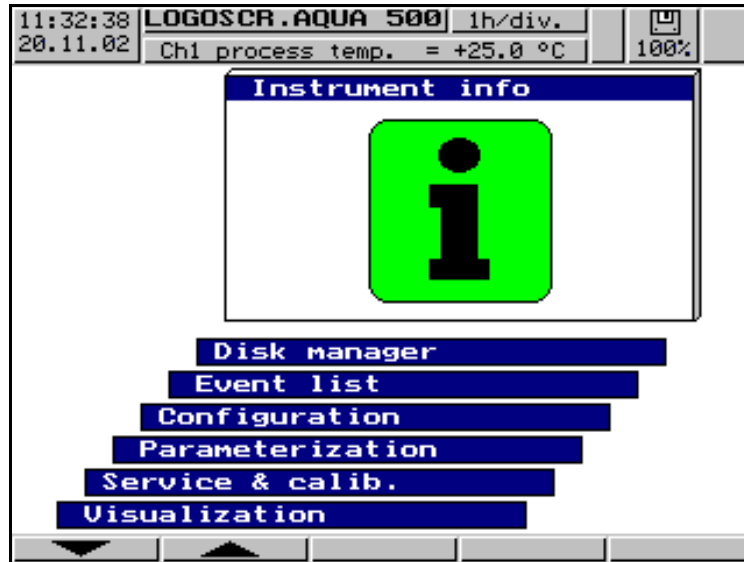

- * Select *Instrument info* level
- * Confirm selection with

Instrument info

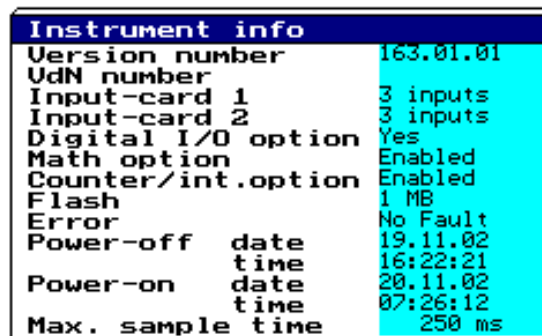
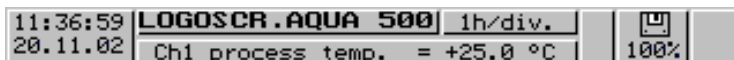

- This menu also includes the version number (e.g. 163.01.01). This is the version number of the instrument software. It is important because some functions are only available from a certain

version number onwards.

- If the “Digital I/O option” is available (Yes), then an RS232/RS485 serial interface is also fitted in the LOGOSCREEN AQUA 500.

Error

The following errors may occur:

Error	Description
none	Instrument OK
Data lost	<p>A discharge of the battery or storage capacitor occurred during the last lengthy power interruption.</p> <p>The clock was set to 01.01.97 00:00:00.</p> <p>Remedy:</p> <ul style="list-style-type: none"> - Reset the time see Chapter 8.5.2 “Configuration - Instrument data”, Page 73. - Update current process values (process temperature and process pH value). - Check settings in the “Service & Calibration” menu.
Battery empty	<p>This message appears on instruments with a lithium battery when the time was reset after a loss of data.</p> <p>Please return the instrument to the supplier for a change of battery.</p>



Data may be lost after separating the instrument from the supply: after more than 10 years on instruments with a lithium battery, and after approx. 2 weeks (at 15 to 25°C ambient temperature) with storage capacitor.

Maximum sampling time

For most applications, the maximum sampling time is 250 msec for six channels.

If concentration or high-purity water measurements are carried out on several channels, then the sampling time may increase for these channels.

The maximum sampling time is determined relative to the run time and is shown in the instrument info.

7 Operation

7.9 Text entry

Entry options

The configurable texts can be entered either through the setup program or on the instrument itself. This section describes the entry on the instrument.

Character selection

The display below is shown when a text (e. g. *Configuration* → *Texts*) has been selected at the configuration level for editing using the ENTER key.



Select the character to be altered using the softkeys

Switch to character set matrix

After the character to be altered has been selected and the switch made to character set matrix, the cursor is positioned on the current character in the character set matrix.

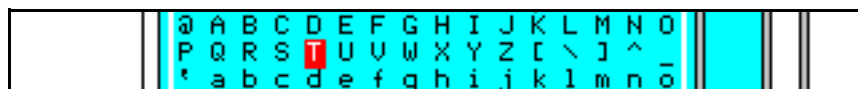

Character entry

The softkeys change their function, as can be seen from the picture below:

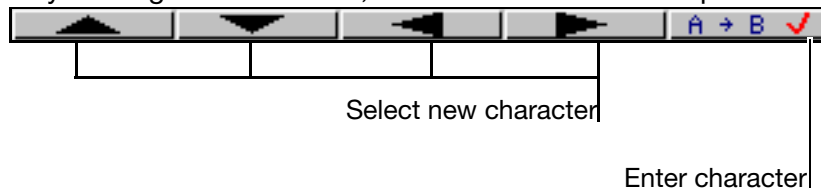

After the entire text has been entered, it can either be accepted or all alterations canceled.

- * Accept text with the ENTER key
or
- * cancel text entry with the EXIT key (quit)

7.10 Code number (password query)

The following functions are protected ex-factory against unauthorized access by a password query:

- the *Configuration* menu
- parts of the *Disk manager* menu
- the *Parameterization* → *Reset counter/int* menu
- the *Service & Calibration* menu

The **factory default setting** for the passwords is **9200**.

You can also secure access to the LOGOSCREEN AQUA 500 via the serial interface by using a password. However, the factory default setting here is 0 (no password query). If you enter a value unequal to 0, please take into account that this number must also be sent to the LOGOSCREEN AQUA 500 by an attached communication program.



Further information about the password query for the serial interface can be found in the Interface Description B 20.2595.2.

All passwords can be programmed differently see Chapter 8.5.2 “Configuration - Instrument data”, Page 73.

Password query



Increase (+1) or decrease (-1) selected digit

Select the digit to be altered

* When the entry has been completed (**+09200**), press the ENTER key.

Cancel: Press EXIT; the password query is stopped and the menu left.

7 Operation

Password query in the Configuration menu

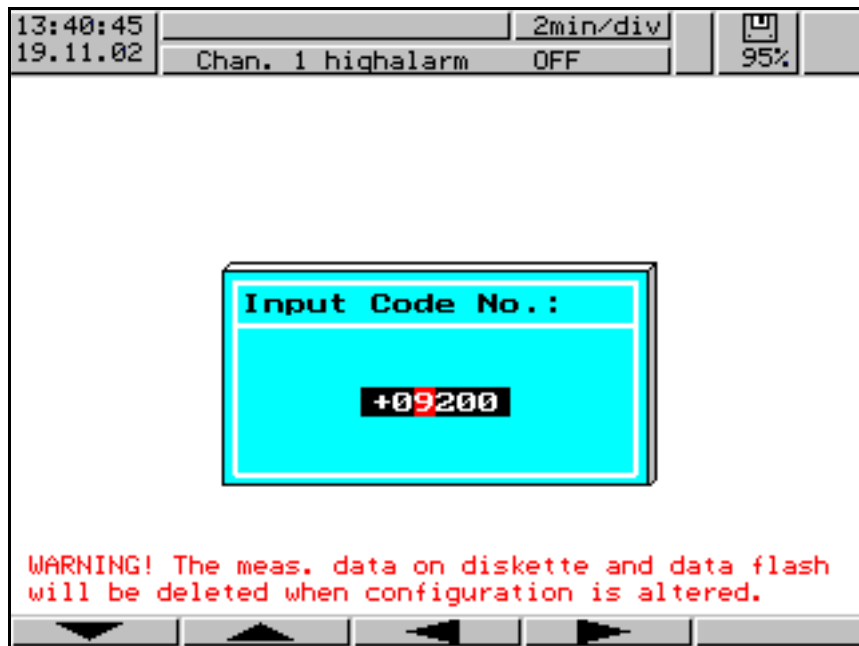

After the password has been entered in the *Configuration* menu, an additional security query will appear. You will only be able to gain access to the parameters when you have confirmed the query with the ENTER key.

8 Configuration parameters

8.1 Operating example

Setting the date

- * Select the *Configuration* menu.
- * Enter code number and press .

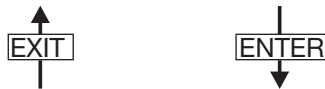
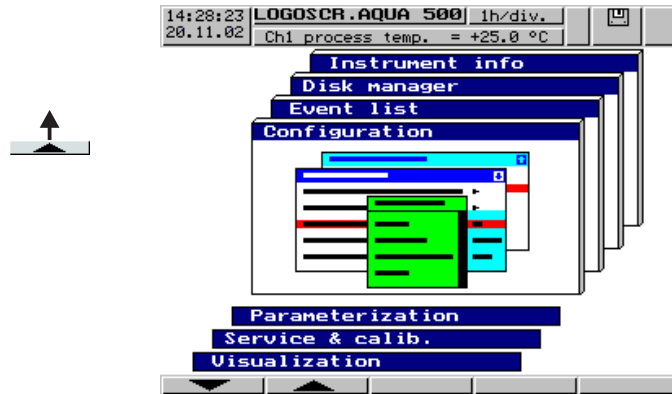

- * Confirm with ENTER or cancel with EXIT. If you use EXIT, the old settings will be retained.

- * Select the *Instrument data* menu



- * Select the *Date and time* menu

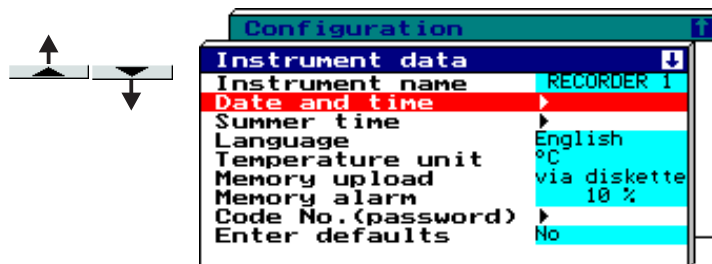

8 Configuration parameters

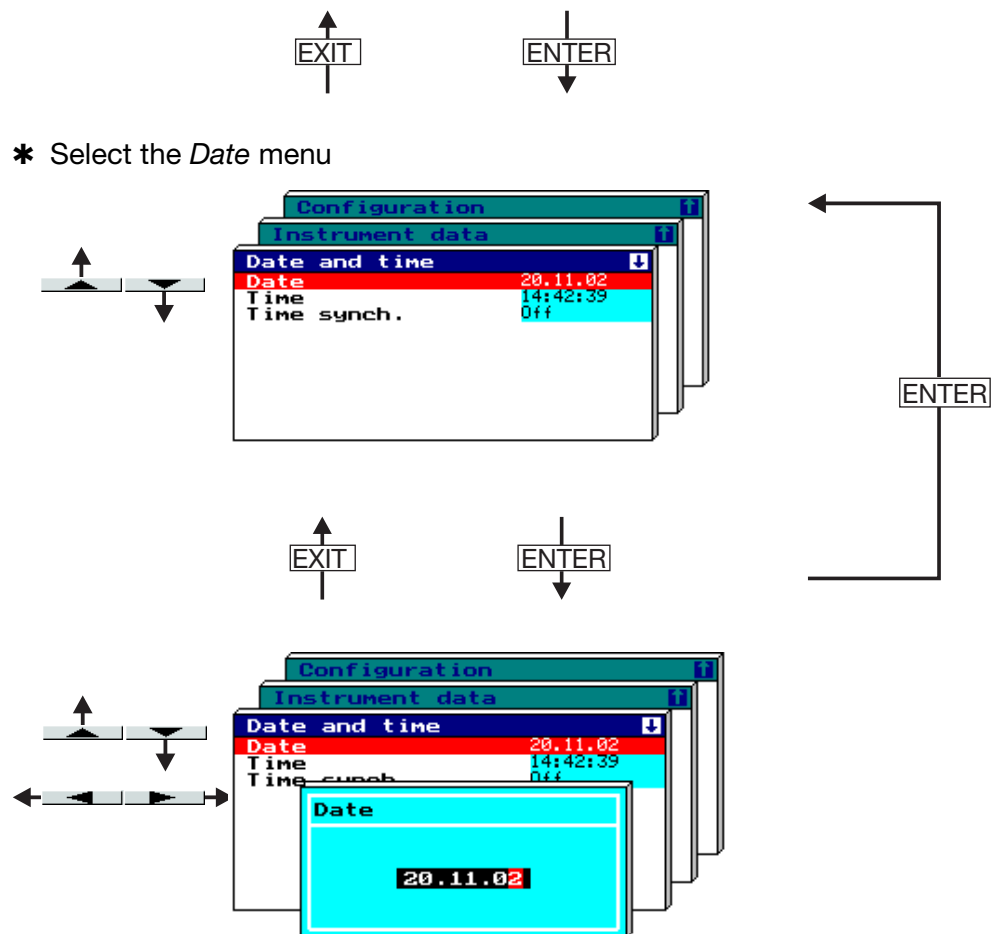

8.2 Before configuring



Caution:

When the instrument is reconfigured:

- **all data will be deleted!**
- **the calibration parameters and calibration values will be reset to the default values!**
- **the logbooks will be deleted and initialized with the default values (preset)!**

You can back up the data on diskette **beforehand**, by using the disk manager.



Tip:

The calibration values and logbooks can be retained, if minor changes **that do not affect the analog inputs** and their electrodes or measuring cells are made in the configuration, **using the instrument keys**.

Minor changes include, for example: setting the time, alteration of code numbers, changes to the text.

8 Configuration parameters

8.3 Configuration



- Free channel selection
- Keep to the given order of the parameters (top to bottom)!
- First configure the channels which are used for temperature and/or pH compensation (free channel selection).
- Parameters which are not relevant at the moment are grayed out and cannot be edited.

8.4 Measurement-specific examples

see Chapter 9 “Configuration examples”, Page 90.

8.5 Table of configuration parameters

The table below lists all the instrument parameters. The order in which the parameters are explained corresponds to the order in which they appear on the instrument (in the menu structure).

The first column describes the path via the menus and windows to the particular parameter.

The second column lists the possible settings for the parameters or the possible selections. The factory default setting in this column is shown **bold**.

The third column contains a description of the parameter, or the possible selections, if the parameter and its function or selection is not self-evident.

8.5.1 Parameterization

	Parameter	Value/selection	Description
Contrast	Parameterization → Contrast	0 – 16 – 31	Contrast of display
Speed indication	Parameterization → Speed indic. mode	in mm/h, Time/div , Storage rate	The selected display mode is shown in the diagram representation
Switch-off event	Parameterization → Display off → Switch-off event	Waiting time , Control signal	The type of display switch-off is selected here
Waiting time	Parameterization → Display off → Waiting time	0 – 32767 min	Time after which the display is switched off. Any key stroke will re-activated the display. The parameter can only be entered if the parameter <i>Switch-off event</i> is set to “Waiting time”. 0 = display not off

8 Configuration parameters

Control signal	Parameterization → Display off → Control signal	Off , Logic inp. 1 – 4	If one of the 4 logic inputs (extra code) is set to “off” and operated, then the display is switched off. The parameter can only be entered if the parameter <i>Switch-off event</i> is set to “Control signal”.
Signal type	Parameterization → Diagram view → Signal type	Analog inp., Analog&Event	Determines which measurements are graphically displayed
Channel representation	Parameterization → Diagram view → Chan. represent.	Meas. small , Scaling, Bar graph, Meas. large, Off	Determines the contents of the channel line (header)
Channel indication	Parameterization → Diagram view → Channel indication → Analog input 1 – 6	Yes , No	“Yes” means that the selected channels are shown in the header
Paper perforations	Parameterization → Diagram view → Paper perforations	No , Yes	“Yes” means that paper perforations are shown within the graphic display, on the left and right margins of the screen. Paper perforations can only be activated and shown if no event traces have been selected (signal type = analog input)
Counter/int. reset	Parameterization → Reset counter/int. → Channel 1 – 6	-999999999 – 0 – +999999999	The start value for the counter or integrator can be entered here. The current value is not saved. Count changes are documented in the event list, see Chapter 7.6 “Event list”, Page 57. If password query is active (password “Reset counter/int.” > 0), the start values can only be set if the password has been entered correctly.

8 Configuration parameters

8.5.2 Configuration - Instrument data

	Parameter	Value/selection	Description
Instrument name	Configuration → Instrument data → Instrument name	16 characters	see Chapter 7.9 "Text entry", Page 66.
Date	Configuration → Instrument data → Date and time → Date	any date	Input of current date
Time	Configuration → Instrument data → Date and time → Time	any time	Input of current time
Time synchronization	Configuration → Instrument data → Date and time → Time synch.	Off , Logic inp. 1 – 4	Using this parameter (function), the system clocks of several LOGOSCREEN can be simultaneously synchronized. When a logic input has been selected and is operated (transition from "Low" to "High"), then the time can be synchronized. The seconds are decisive in the time change. They are used for rounding the time up or down. Example: 12:55:29 -> 12:55:00 12:55:30 -> 12:56:00
Summer time (switch)	Configuration → Instrument data → Summer time → Switch	Off, User timed, Automatic	Automatic: 2:00 hrs or 3:00 hrs on the last Sunday in March or October
Summer time (start date)	Configuration → Instrument data → Summer time → Start date	any date	only adjustable if the changeover (switch) is set to "User timed"
Summer time (start time)	Configuration → Instrument data → Summer time → Start time	any time	only adjustable if the changeover (switch) is set to "User timed"
Summer time (end date)	Configuration → Instrument data → Summer time → End date	any date	only adjustable if the changeover (switch) is set to "User timed"
Summer time (end time)	Configuration → Instrument data → Summer time → End time	any time	only adjustable if the changeover (switch) is set to "User timed"

8 Configuration parameters

Language	Configuration → Instrument data → Language	German, English, French	
Temperature unit	Configuration → Instrument data → Temperature unit	°C, °F	
Memory upload	Configuration → Instrument data → Memory upload	with diskette, via RSxxx	You can determine how data are mainly to be uploaded. The details about the available capacity (shown in the status line) vary according to the selection.
Memory alarm (diskette reserve)	Configuration → Instrument data → Memory alarm	1 – 10 – 100%	The signal is activated when the residual capacity of the diskette, or of the internal memory has fallen to this value. The parameter <i>Memory upload</i> determines whether the alarm was caused by the diskette or the memory, see Chapter 6.5.2 “Event traces”, Page 34
Code number of configuration	Configuration → Instrument data → Code No. (password) → Configuration	0000 – 9200 – 9999	Code number for configuration level; 0000 = off The data saved on diskette and in the FLASH memory are deleted when the configuration is changed.
Code number of disk manager (Disk code no.)	Configuration → Instrument data → Code No. (password) → Disk manager	0000 – 9200 – 9999	Code number for functions in the <i>File manager</i> menu; 0000 = off
Code number Counter/int.reset	Configuration → Instrument data → Code No. (password) → Reset counter/int.	0000 – 9200 – 9999	Code number to delete individual counts; 0000 = off
Code number RS232/RS485	Configuration → Instrument data → Code No. (password) → RS232/RS485	0000 – 9999	Code number to prevent unauthorized access to the data via the serial interface; 0000 = off
Code number Service / Calibration	Configuration → Instrument data → Code No. (password) → Service/calib.	0000 – 9999	Code number to prevent unauthorized access to the calibration; 0000 = off
Enter factory default setting	Configuration → Instrument data → Enter defaults	No, Yes	Yes = enter factory default setting (when entered, the parameter automatically returns to No)

8 Configuration parameters

8.5.3 Configuration - Analog inputs

	Parameter	Value/selection	Description
Measured variable	Configuration → Analog inputs → Analog input 1 – 6 → Measured variable	None, Temperature, pH value, Redox, Conductivity, HPW neutral, HPW acid, HPW alkaline, Chlorine, ClO ₂ , Ozone, Sulf. acid, Nitric acid, HCl acid, NaCl, NaOH, KOH non-linear, linear, Math	Select which variable is to be measured, see Chapter 9 “Configuration examples”, Page 90. With the “non-linear” setting, linearization is performed through a customized linearization table.
Range	Configuration → Analog inputs → Analog input 1 – 6 → Range	Range I Range II Range III	Sulfuric acid to potassium hydroxide: Select in which concentration range you want to measure, see Chapter 3.1 “Analog inputs”, Page 14.
Dimensional unit	Configuration → Analog inputs → Analog input 1 – 6 → Dimensional unit	μS/cm mS/cm MΩ*cm ppm	Dimensional unit for outputting the conductivity or high-purity water measurement
Signal source	Configuration → Analog inputs → Analog input 1 – 6 → Signal source	none, RTD Imp. conv. (impedance converter), Tran.+lin. (transmitter with linearization), Tran.no-lin. (transmitter without linearization), Tran.+comp. (transmitter with compensation) Tran.no-comp (transmitter without compensation), Tran.+corr. (transmitter with correction), Tran.no-corr (transmitter without correction), Transmitter	Selection of instrument that provides the input signal or transmits the measurement, or whether or not the signal source has already carried out measurement linearization, compensation or correction.
Input signal	Configuration → Analog inputs → Analog input 1 – 6 → Signal source → Input signal	Off, RTD, Current, Voltage	Signal (from RTD, impedance converter or transmitter) which is present at the analog input terminal.

8 Configuration parameters

	Parameter	Value/selection	Description
Linearization	Configuration → Analog inputs → Analog input 1 – 6 → Signal source → Linearization	Pt100 Pt500 Pt1000 Customized 1 Customized 2 Customized 3	The required tables are available in the instrument for temperature measurement. Customer-specific linearization tables for non-linear variables can be entered via the setup program, see Chapter 12.4 “Customized linearization”, Page 157.
Connection circuit	Configuration → Analog inputs → Analog input 1 – 6 → Signal source → Connection circuit	2-wire 3-wire 4-wire	Selection of connection type for RTD
Range start	Configuration → Analog inputs → Analog input 1 – 6 → Signal source → Range start	any value 0.0000	Start value of input signal at the analog input terminal provided by the signal source.
Range end	Configuration → Analog inputs → Analog input 1 – 6 → Signal source → Range end	any value 20.000 mA	End value of input signal at the analog input terminal provided by the signal source.
Start temperature	Configuration → Analog inputs → Analog input 1 – 6 → Signal source → Start temperature		For temperature measurement: the start temperature of the range that can be measured by the signal source.
End temperature	Configuration → Analog inputs → Analog input 1 – 6 → Signal source → End temperature		For temperature measurement: the end temperature of the range that can be measured by the signal source.
Start of transmission range	Configuration → Analog inputs → Analog input 1 – 6 → Signal source → Trans. range start	0 – 100% 0.000%	Start value of measurement range that is transmitted by the impedance converter or transmitter via the current or voltage signal.
End of transmission range	Configuration → Analog inputs → Analog input 1 – 6 → Signal source → Trans. range end	0 – 100% 100.00%	End value of measurement range that is transmitted by the impedance converter or transmitter via the current or voltage signal.

8 Configuration parameters

	Parameter	Value/selection	Description
Filter constant	Configuration → Analog inputs → Analog input 1 – 6 → Signal source → Filter constant	0 – 10 s +0.1000 s	- digital - second order
Temperature compensation	Configuration → Analog inputs → Analog input 1 – 6 → Compensation → Temperature compensation	manual, Analog inp. x	Temperature measurement for temperature compensation can take place either manually or automatically, via a different channel. However, this channel has to be configured as a temperature channel!
Process temperature	Configuration → Analog inputs → Analog input 1 – 6 → Compensation → Process temperature	-50 to 25 to 250°C	Entry of the process temperature for temperature compensation, with manual temperature measurement. If the temperature varies during recording, then the process temperature can also be entered in the <i>Service & Calibration</i> menu, see Chapter 10.7 “Table of service and calibration parameters”, Page 124.
Reference temperature	Configuration → Analog inputs → Analog input 1 – 6 → Compensation → Reference temperature	-50 to 25 to 250°C	Reference temperature for temperature compensation, with conductivity measurement (mostly 25°C).
pH value compensation	Configuration → Analog inputs → Analog input 1 – 6 → Compensation → pH value comp.	manual, Analog inp. x	Only for measurement of free chlorine: The pH value measurement for pH value compensation can take place automatically, via a different channel. However, this channel has to be configured as a pH channel!

8 Configuration parameters

	Parameter	Value/selection	Description
Process pH	Configuration → Analog inputs → Analog input 1 – 6 → Compensation → Process pH	Temperature comp. ¹ Process temp. ² Ref. temp. ³ pH value comp. ⁴ Process pH ⁵	Entry of the process pH value for pH value compensation, with manual pH measurement. If the pH value varies during recording, then the process pH value can also be entered in the <i>Service & Calibration</i> menu, see Chapter 10.7 “Table of service and calibration parameters”, Page 124.
Channel name	Configuration → Analog inputs → Analog input 1 – 6 → Channel name	7 characters Inp. 1	Short designation. It is shown in the channel line (header) with bar graph and scaling, see Chapter 7.9 “Text entry”, Page 66.
Unit	Configuration → Analog inputs → Analog input 1 – 6 → Unit	5 characters %	Measurement unit, see Chapter 7.9 “Text entry”, Page 66.
Scaling start	Configuration → Analog inputs → Analog input 1 – 6 → Scaling start	-99999 to 0 to +99999 (value range depends on configured variable to be measured.)	Start and end value of the range within which the measurement can be determined and displayed. At the same time, it is the start value for the scale and bar graph marking in visualization. Often it is identical with the transmission range values (not selectable in this case). Exception: In the case of redox, conversion to a different unit (e.g. %) is possible via a linear equation.
Scaling end	Configuration → Analog inputs → Analog input 1 – 6 → Scaling end	-99999 to 0 to +99999 (value range depends on configured variable to be measured.)	
Decimal place	Configuration → Analog inputs → Analog input 1 – 6 → Decimal place	Automatic, X.XXXX, XX.XXX, XXX.XX, XXXX.X , XXXXX.	Automatic: representation with maximum resolution
Line width	Configuration → Analog inputs → Analog input 1 – 6 → Line width	Thin , Thick	Line width of the measurement curve within the graphical display
Alarm	Configuration → Analog inputs → Analog input 1 – 6 → Alarm	Off , Activated	Switch limit monitoring for measurement on or off.

8 Configuration parameters

	Parameter	Value/selection	Description
Low limit	Configuration → Analog inputs → Analog input 1 – 6 → Alarm → Low limit	-99999 to 0 to +99999	
High limit	Configuration → Analog inputs → Analog input 1 – 6 → Alarm → High limit	-99999 to 0 to +99999	
Differential	Configuration → Analog inputs → Analog input 1 – 6 → Alarm → Differential	-99999 to 0 to +99999	
	(1) = Low limit (2) = High limit (3) = Differential		
Text low alarm	Configuration → Analog inputs → Analog input 1 – 6 → Alarm → Text low alarm	Standard text, Text 1 – 18, No text	see Chapter 7.6 “Event list”, Page 57. see Chapter 8.5.9 “Configuration - Texts”, Page 87.
Text high alarm	Configuration → Analog inputs → Analog input 1 – 6 → Alarm → Text high alarm	Standard text, Text 1 – 18, No text	
Alarm delay	Configuration → Analog inputs → Analog input 1 – 6 → Alarm → Alarm delay	0 – 32767 s	Alarm delay is activated at a value of > 0. When activated, an alarm will only be generated when it has been present for at least as long as it takes for the set time to elapse.

8 Configuration parameters

8.5.4 Configuration - Event traces

	Parameter	Value/selection	Description
Input signal	Configuration → Event traces → Event traces 1 – 6 → Input signal	Off, Logic inp. 1 – 4, Logic channel 1 – 6, Low alarm 1 – 6, Low comb.al., High alarm 1 – 6, High comb.al., Cnt./in.al. 1 – 6, C/i.comb.al., Comb. alarm, El.calib. 1 – 6, El.calib., Memory alarm, Error, Modbus flag	The event (digital signal) which is to be recorded is assigned to an event trace. Presetting: Event traces 1 – 4: Logic inp. 1 – 4, Event traces 5 – 6: Off
Trace designation	Configuration → Event traces → Event traces 1 – 6 → Trace design.	7 characters BE 1 – 4	Presetting: Event traces 1 – 4: Logic input (BE) 1 – 4 Event traces 5 – 6: xxxx see Chapter 7.9 “Text entry”, Page 66.

8 Configuration parameters

8.5.5 Configuration - Counter/integrator (extra code)

	Parameter	Value/selection	Description
Channel	Configuration → Counter/integrator → Counter/int.chans.	1 – 6	Select channel for which the subsequent parameters are to be configured.
Function	Configuration → Counter/integrator → Counter/int.chans. → Channel 1 – 6 → Function	Off , Counter, Integrator, Oper. time	Select the desired function here, see Chapter 6.6 “Counters / integrators / oper. time counters (extra code)”, Page 35.
Type	Configuration → Counter/integrator → Counter/int.chans. → Channel 1 – 6 → Type	Periodic, External, Daily , Weekly, Monthly, Yearly, Total, Daily from-to	Reporting period. Select here when the count is to be stored and reset.
Input signal	Configuration → Counter/integrator → Counter/int.chans. → Channel 1 – 6 → Input signal	Off, Logic inp. 1 – 4, Logic channel 1 – 6, Low alarm 1 – 6, Low comb.al., High alarm 1 – 6, High comb.al., Cnt./in.al. 1 – 6, C/i.comb.al., Comb. alarm, El.calib. 1 – 6, El.calib., Memory alarm , Error, Modbus flag	The parameter can only be programmed if “Counter” or “Operating time” has been selected under <i>Function</i> . Please select which event is to be counted.
Input signal	Configuration → Counter/integrator → Counter/int.chans. → Channel 1 – 6 → Input signal	Analog inp. 1 – 3 or Analog inp. 1 – 6	The parameter can only be programmed if “Integrator” has been selected under <i>Function</i> . Please select which input is to be integrated.
Weighting	Configuration → Counter/integrator → Counter/int.chans. → Channel 1 – 6 → Weighting	-99999 to +1 to +99999	Select the weighting factor here. If, for instance, 0.001 is entered, then a conversion from liter/sec to m ³ can be achieved. If a negative weighting factor is entered (e.g. -1), the counter will count down.

8 Configuration parameters

Time base	<p>Configuration</p> <ul style="list-style-type: none"> → Counter/integrator <ul style="list-style-type: none"> → Counter/int.chans. <ul style="list-style-type: none"> → Channel 1 – 6 <ul style="list-style-type: none"> → Time base 	<p>Second, Minute, Hour, Day</p>	<p>The parameter can only be programmed if “Integrator” or “Operating time” has been selected under <i>Function</i>.</p> <p>Integrator: Select the time base for integrating the selected channel (seconds, for example, when your sensor generates a signal in liters/second).</p> <p>Operating time: Select the unit used for counting the time.</p>
Threshold value	<p>Configuration</p> <ul style="list-style-type: none"> → Counter/integrator <ul style="list-style-type: none"> → Counter/int.chans. <ul style="list-style-type: none"> → Channel 1 – 6 <ul style="list-style-type: none"> → Threshold value 	<p>0 – 99999</p>	<p>The parameter can only be programmed if “Integrator” has been selected under <i>Function</i>.</p> <p>Enter the threshold value that has to be exceeded for integration.</p>
Channel name (line 1)	<p>Configuration</p> <ul style="list-style-type: none"> → Counter/integrator <ul style="list-style-type: none"> → Counter/int.chans. <ul style="list-style-type: none"> → Channel 1 – 6 <ul style="list-style-type: none"> → Channel name 	<p>7 characters</p> <p>Counter/</p>	<p>The text that has been entered appears together with line 2 and the current count on the recorder screen (visualization and event list), see Chapter 6.6 “Counters / integrators / oper. time counters (extra code)”, Page 35.</p>
Channel name (line 2)	<p>Configuration</p> <ul style="list-style-type: none"> → Counter/integrator <ul style="list-style-type: none"> → Counter/int.chans. <ul style="list-style-type: none"> → Channel 1 – 6 <ul style="list-style-type: none"> → Channel name 	<p>7 characters</p> <p>Integrx</p>	<p>The text that has been entered appears together with line 1 and the current count on the recorder screen (visualization and event list).</p>
Unit	<p>Configuration</p> <ul style="list-style-type: none"> → Counter/integrator <ul style="list-style-type: none"> → Counter/int.chans. <ul style="list-style-type: none"> → Channel 1 – 6 <ul style="list-style-type: none"> → Unit 	<p>5 characters</p>	<p>Enter the unit which is displayed on the recorder screen, together with the entered text and the current count.</p>
Decimal place	<p>Configuration</p> <ul style="list-style-type: none"> → Counter/integrator <ul style="list-style-type: none"> → Counter/int.chans. <ul style="list-style-type: none"> → Channel 1 – 6 <ul style="list-style-type: none"> → Decimal place 	<p>Automatic, X.XXXX, XX.XXX, XXX.XX, XXXX.X, XXXXX.</p>	<p>Specify the decimal place for displaying the count on the recorder screen.</p>
Counter text	<p>Configuration</p> <ul style="list-style-type: none"> → Counter/integrator <ul style="list-style-type: none"> → Counter/int.chans. <ul style="list-style-type: none"> → Channel 1 – 6 <ul style="list-style-type: none"> → Counter text 	<p>Standard text, Text 1 – 18, No text</p>	<p>If the counter is incremented (decremented), the text selected here will appear in the status line and the event list.</p>

8 Configuration parameters

Alarm	Configuration → Counter/integrator → Counter/int.chans. → Channel 1 – 6 → Alarm → Alarm	Off, Activated	
Limit value	Configuration → Counter/integrator → Counter/int.chans. → Channel 1 – 6 → Alarm → Limit value	-99999 to 100 to +99999	An alarm is triggered when the limit is infringed. Using the parameter <i>Weighting</i> , it is possible to differentiate between going above or below the limit (positive weighting factor = alarm on going above the limit)
Alarm text	Configuration → Counter/integrator → Counter/int.chans. → Channel 1 – 6 → Alarm → Alarm text	Standard text, Text 1 – 18, No text	On going above/below the limit, the text selected here will appear in the status line and the event list.
Synchronizing time	Configuration → Counter/integrator → Synchronizing time	any time (00:00:00)	Please enter the time at which the daily, weekly, monthly or yearly counter/integrator value is to be saved.
Period	Configuration → Counter/integrator → Period	1 min, 2min , 3min, 4min, 5min, 10min, 15min, 30min, 1h, 2h, 3h, 4h, 6h, 8h, 12h	Only programmable, if the parameter <i>Type</i> is set to “periodic” on at least one counter/integrator. The counter/integrator values are saved at the selected interval.
Ext. control signal	Configuration → Counter/integrator → Ext. control signal	Logic inp. 1 – 4, Logic channel 1 – 6, Low alarm 1 – 6, Low comb.al., High alarm 1 – 6, High comb.al., Cnt./in.al. 1 – 6, C/i.comb.al., Comb. alarm, El.calib. 1 – 6, El.calib., Memory alarm, Error, Modbus flag	Only programmable, if the parameter <i>Type</i> is set to “external” on at least one counter/integrator. Summation of the counter/integrator values will only take place if the selected digital signal is set to “1”. When changing to “0”, the values are saved and reset.
Weekday	Configuration → Counter/integrator → Weekday	Monday, Tuesday, Wednesday, Thursday, Friday, Saturday, Sunday	Only programmable, if the parameter <i>Type</i> is set to “Weekly” on at least one counter/integrator. The counter/integrator values are saved on the selected day on reaching the synchronizing time.

8 Configuration parameters

Daily start time	Configuration → Counter/integrator → Daily start time	any time (06:00:00)	Only programmable, if the parameter <i>Type</i> is set to “Daily from-to” on at least one counter/integrator.
Daily end time	Configuration → Counter/integrator → Daily end time	any time (18:00:00)	Only programmable, if the parameter <i>Type</i> is set to “Daily from-to” on at least one counter/integrator.
Generate reset	Configuration → Counter/integrator → Generate reset	Off, Logic inp. 1 – 4, Logic channel 1 – 6, Low alarm 1 – 6, Low comb.al., High alarm 1 – 6, High comb.al., Cnt./in.al. 1 – 6, C/i.comb.al., Comb. alarm, El.calib. 1 – 6, El.calib., Memory alarm, Error, Modbus flag	Here you can determine the event which will reset all counter and integrator counts (without storing), see Chapter 6.6.5 “Resetting the counters / integrators / operating time counters”, Page 37.

8 Configuration parameters

8.5.6 Configuration - Measurement storage

	Parameter	Value/selection	Description
Store status Normal operation	Configuration → Meas. storage → Normal operation → Store status	Off, On	
Stored value Normal operation	Configuration → Meas. storage → Normal operation → Stored value	Average val., Instant. val., Minimum val., Maximum val., Peak value	see Chapter 6.8 "Operating modes", Page 41, see Chapter 6.9 "Data storage", Page 42.
Storage rate Normal operation	Configuration → Meas. storage → Normal operation → Storage rate	1 – 60 – 32767s	see Chapter 6.8 "Operating modes", Page 41, see Chapter 6.9 "Data storage", Page 42.
Control signal Event operation	Configuration → Meas. storage → Event operation → Control signal	Off , Logic inp. 1 – 4, Logic channel 1 – 6, Low alarm 1 – 6, Low comb.al., High alarm 1 – 6, High comb.al., Cnt./in.al. 1 – 6, C/i.comb.al., Comb. alarm, El.calib. 1 – 6, El.calib., Memory alarm, Error, Modbus flag	When the configured signals is active, the instrument switches to event operation.
Stored value Event operation	Configuration → Meas. storage → Event operation → Stored value	Average val., Instant. val., Minimum val., Maximum val., Peak value	see Chapter 6.8 "Operating modes", Page 41, see Chapter 6.9 "Data storage", Page 42.
Storage rate Event operation	Configuration → Meas. storage → Event operation → Storage rate	1 – 5 – 32767s	see Chapter 6.8 "Operating modes", Page 41, see Chapter 6.9 "Data storage", Page 42.
Start time Timed operation	Configuration → Meas. storage → Timed operation → Start time	any time	Off when start time = end time
End time Timed operation	Configuration → Meas. storage → Timed operation → End time	any time	

8 Configuration parameters

Stored value Timed operation	Configuration → Meas. storage → Timed operation → Stored value	Average val., Instant. val., Minimum val., Maximum val., Peak value	see Chapter 6.8 “Operating modes”, Page 41, see Chapter 6.9 “Data storage”, Page 42.
Storage rate Timed operation	Configuration → Meas. storage → Timed operation → Storage rate	1 – 5 – 32767s	see Chapter 6.8 “Operating modes”, Page 41, see Chapter 6.9 “Data storage”, Page 42.

8.5.7 Configuration - Outputs (extra code)



A relay is assigned to a software signal (value/selection) here.

	Parameter	Value/selection	Description
Action Outputs	Configuration → Outputs → Relay K1 – K3 → Action	Off, n.o. (make), n.c. (break)	Presetting: Relay K1: n.c. (break) Relay K2 – K3: Off
Control signal Outputs	Configuration → Outputs → Relay K1 – K3 → Control signal	Off, Logic inp. 1 – 4, Logic channel 1 – 6, Low alarm 1 – 6, Low comb.al., High alarm 1 – 6, High comb.al., Cnt./in.al. 1 – 6, C/i.comb.al., Comb. alarm, El.calib. 1 – 6, El.calib., Memory alarm, Error, Modbus flag	The configured signal is output to a relay. Presetting: Relay K1: Error Relay K2 – K3: Off

8 Configuration parameters

8.5.8 Configuration - Control functions

	Parameter	Value/selection	Description
External texts Logic input 1 – 4	Configuration → Control functions → External texts → Logic input 1 – 4	Standard text, Text 1 – 18, No text	see Chapter 7.6 “Event list”, Page 57, see Chapter 8.5.9 “Configuration - Texts”, Page 87.
External texts Logic channel 1 – 6	Configuration → Control functions → External texts → Logic channel 1 – 6	Standard text, Text 1 – 18, No text	Can only be used if the “Math/logic module” option is available, see Chapter 7.6 “Event list”, Page 57, see Chapter 8.5.9 “Configuration - Texts”, Page 87.
Key inhibit	Configuration → Control functions → Key inhibit	Off , Logic inp. 1 – 4, Logic channel 1 – 6, Low alarm 1 – 6, Low comb.al., High alarm 1 – 6, High comb.al., Cnt./in.al. 1 – 6, C/i.comb.al., Comb. alarm, El.calib. 1 – 6*, El.calib.*, Memory alarm, Error, Modbus flag	As soon as the selected signal is activated, the keys are inhibited. * El.calib. 1 – 6 and El.calib. cannot be selected.

8.5.9 Configuration - Texts

	Parameter	Value/selection	Description
Texts	Configuration → Texts → Text 1 – 18	20 characters Text 1 – 18	see Chapter 7.9 “Text entry”, Page 66.

8 Configuration parameters

8.5.10 Configuration - Interface

	Parameter	Value/selection	Description
Interface type	Configuration → Interface → Interface type	RS232, RS485	Selection of the serial interface (extra code)
Protocol	Configuration → Interface → Protocol	MODBUS , JBUS	
Baud rate	Configuration → Interface → Baud rate	9600 Baud, 19200 Baud, 38400 Baud	
Data format	Configuration → Interface → Data format	8-1-none , 8-1-odd, 8-1-even, 8-2-none	
Instrument address	Configuration → Interface → Instrument address	1 – 255	
Min. response time	Configuration → Interface → Min. response time	0 – 500ms	

8.5.11 Configuration - Fine calibration

	Parameter	Value/selection	Description
Calibration status	Configuration → Fine calibration → Analog input 1 – 6 → Calibration status	Off , On	A calibration (adjustment) of the analog measurements can be activated here. The adjustment is carried out using a linear equation.
Actual start value	Configuration → Fine calibration → Analog input 1 – 6 → Actual start value	-99999 to 0 to +99999	Start value of the actual line. Only active when calibration status = On.
Set start value	Configuration → Fine calibration → Analog input 1 – 6 → Set start value	-99999 to 0 to +99999	Start value of the set line. Only active when calibration status = On.
Actual end value	Configuration → Fine calibration → Analog input 1 – 6 → Actual end value	-99999 to 1000 to +99999	End value of the actual line. Only active when calibration status = On.
Set end value	Configuration → Fine calibration → Analog input 1 – 6 → Set end value	-99999 to 1000 to +99999	End value of the set line. Only active when calibration status = On.

8 Configuration parameters



Systematic errors, such as those caused by an unsuitable probe mounting, for example, can be compensated through fine calibration.

Example:

A probe covers a temperature range from 200 to 300°C. It has been installed in a tunnel oven so unfavorably as to always indicate 10°C less than the temperature of the charge. The incorrect measurement can be corrected through fine calibration.

Actual start value: 200°C

Set start value : 210°C

Actual end value : 300°C

Set end value : 310°C

9 Configuration examples

9.1 pH measurement

Setting up a measurement system

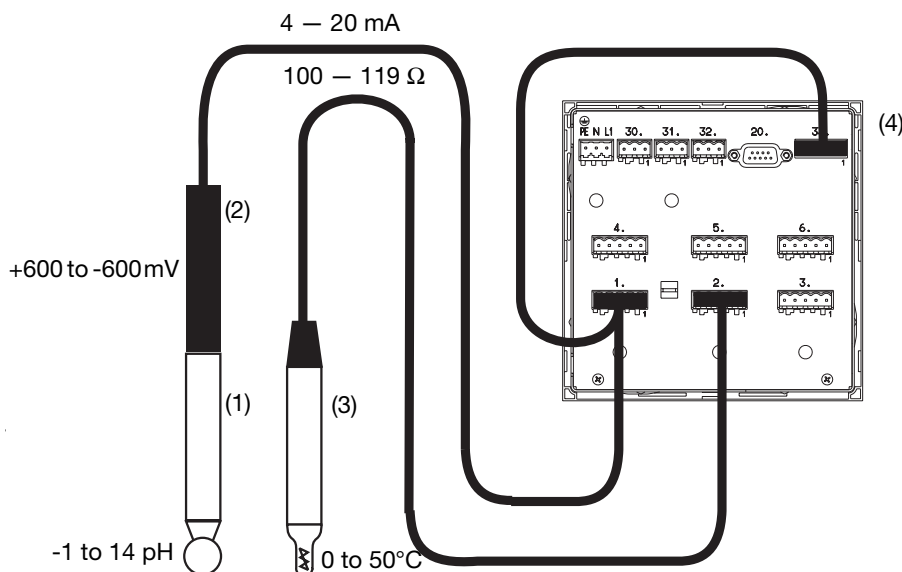

Note:

Only operate a 2-wire transmitter from the internal power supply (terminal 33)!

No.	Designation	JUMO Data Sheet
(1)	pH combination electrode	20.2900
(2)	JUMO 2-wire transmitter for pH, Type 202701	20.2701
(3)	Pt100 temperature probe	20.2900
(4)	LOGOSCREEN AQUA 500	20.2595

The pH combination electrode (1) generates a voltage of +600 to -600 mV, depending on the pH of the solution.

This voltage is measured by the downstream 2-wire transmitter for pH (2), which has a high-resistance input, and converted into a standard 4 – 20 mA signal.

This standard signal arrives at the analog input of the LOGOSCREEN AQUA 500 (4) and is processed there.

The pH value is dependent on temperature. For temperature compensation of the pH value, a temperature probe (Pt100 resistance thermometer), which has a resistance signal that can be directly processed, is connected to the LOGOSCREEN AQUA 500.

Settings



The example is based on the assumption that the 2-wire transmitter for pH is connected to input channel 1 of the LOGOSCREEN AQUA 500.

A temperature probe (Pt100 resistance thermometer) is connected to the input channel 2 of the LOGOSCREEN AQUA 500.

If you intend to use the temperature probe for temperature compensation of the pH value, then this probe has to be configured first!

9 Configuration examples

Configuration of the temperature probe

Parameter	Configuration	Value / selection	Description
Temperature measurement on channel 2	→ Analog inputs → Analog input 2 → Measured variable	Temperature	see Chapter 8.5.3 “Configuration - Analog inputs”, Page 75
Signal source	→ Analog inputs → Analog input 2 → Signal source	RTD	
Linearization	→ Analog inputs → Analog input 2 → Signal source → Linearization	Pt100	
Connection circuit	→ Analog inputs → Analog input 2 → Signal source → Connection circuit	2-wire or 3-wire or 4-wire	
Start temperature	→ Analog inputs → Analog input 2 → Signal source → Start temperature	0.0000°C (for example)	
End temperature	→ Analog inputs → Analog input 2 → Signal source → End temperature	50.000°C (for example)	
Channel name	→ Analog inputs → Analog input 2 → Channel name	Inp. 2 (variable text)	
Unit	→ Analog inputs → Analog input 2 → Unit	°C (variable text)	
Decimal place	→ Analog inputs → Analog input 2 → Decimal place	Automatic x.xxxx xx.xxx xxx.xx xxxx.x xxxxx.	
Line width	→ Analog inputs → Analog input 2 → Line width	Thin Thick	
Alarm	→ Analog inputs → Analog input 2 → Alarm	Off Activated	see Chapter 8.5.3 “Configuration - Analog inputs”, Page 75

9 Configuration examples

Configuration of the pH input

Parameter	Configuration	Value / selection	Description
Measured variable	→ Analog inputs → Analog input 1 → Measured variable	pH value	
Signal source	→ Analog inputs → Analog input 1 → Signal source	Tran.no-comp. (transmitter without compensation)	
Input signal	→ Analog inputs → Analog input 1 → Input signal	Current	
Range start	→ Analog inputs → Analog input 1 → Range start	4.0000 mA	
Range end	→ Analog inputs → Analog input 1 → Range end	20.000 mA	
Start of transmission range	→ Analog inputs → Analog input 1 → Transmission range start	+600.00 mV (transmitter data)	
End of transmission range	→ Analog inputs → Analog input 1 → Transmission range end	-600.00 mV (transmitter data)	
Temperature compensation	→ Analog inputs → Analog input 1 → Compensation → Temperature comp.	Analog inp.2 Analog input 2 can only be selected if it has already been configured as a temperature channel. Note: If "manual" has been selected in place of an analog input, the process temperature can be entered.	
Channel name	→ Analog inputs → Analog input 1 → Channel name	Inp.1 (variable text)	
Unit	→ Analog inputs → Analog input 1 → Unit	pH (variable text)	
Scaling start	→ Analog inputs → Analog input 1 → Scaling start	-1.0000 (scaling of the diagram representation)	Start value of the range within which the pH value is determined and displayed.

9 Configuration examples

Parameter	Configuration	Value / selection	Description
Scaling end	→ Analog inputs → Analog input 1 → Scaling end	14.000 (scaling of the diagram representation)	End value of the range within which the pH value is determined and displayed.
Decimal place	→ Analog inputs → Analog input 1 → Decimal place	Automatic x.xxxx xx.xxx xxx.xx xxxx.x xxxxx.	
Line width	→ Analog inputs → Analog input 1 → Line width	Thin Thick	
Alarm	→ Analog inputs → Analog input 1 → Alarm	Off Activated	see Chapter 8.5.3 “Configuration - Analog inputs”, Page 75.

9 Configuration examples

9.2 Redox measurement

Setting up a measurement system

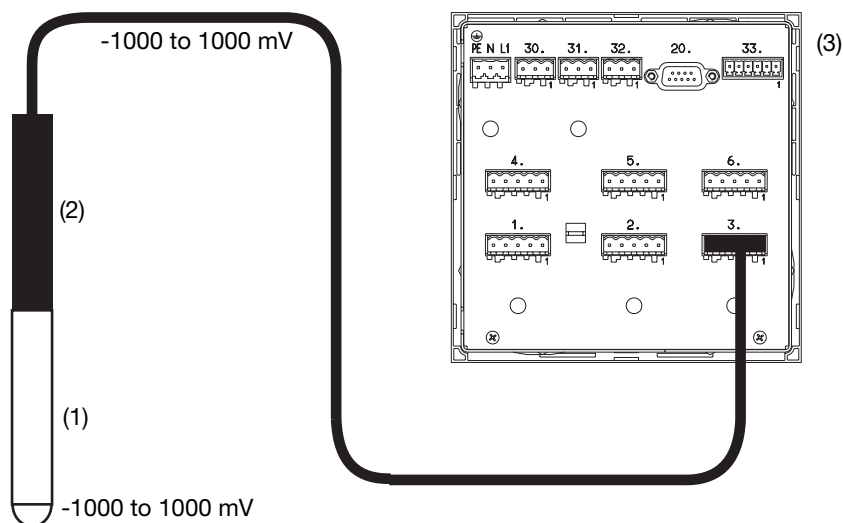

No.	Description	JUMO Data Sheet
(1)	Metal combination electrode	20.2900
(2)	JUMO impedance converter	20.2995
(3)	LOGOSCREEN AQUA 500	20.2595

The redox potential of a solution is measured by a combination electrode (1). The impedance converter (2) transmits this high-impedance voltage signal as a low-impedance signal to the LOGOSCREEN AQUA 500 (3). Temperature drifts are usually not taken into account with redox measurement.

Settings



The example is based on the assumption that the impedance converter is connected to input channel 3 of the LOGOSCREEN AQUA 500.

Configuration of the redox input

Parameter	Configuration	Value / selection	Description
Measured variable	→ Analog inputs → Analog input 3 → Measured variable	Redox	
Signal source	→ Analog inputs → Analog input 3 → Signal source	Imp. conv. (impedance converter)	
Input signal	→ Analog inputs → Analog input 3 → Input signal	Voltage	

9 Configuration examples

Parameter	Configuration	Value / selection	Description
Range start	→ Analog inputs → Analog input 3 → Range start	-1000.0 mV	
Range end	→ Analog inputs → Analog input 3 → Range end	+1000.0 mV	
Channel name	→ Analog inputs → Analog input 3 → Channel name	Inp. 3 (variable text)	
Unit	→ Analog inputs → Analog input 3 → Unit	mV (variable text)	
Scaling start	→ Analog inputs → Analog input 3 → Scaling start	-1000.0 mV	The value should correspond to the range start. Exception: If the value needs to be recalculated to a different unit (e.g. %) via a linear equation.
Scaling end	→ Analog inputs → Analog input 3 → Scaling end	+1000.0 mV	The value should correspond to the range end. Exception: If the value needs to be recalculated to a different unit (e.g. %) via a linear equation.
Decimal place	→ Analog inputs → Analog input 3 → Decimal place	Automatic x.xxxx xx.xxx xxx.xx xxxx.x xxxxx.	
Line width	→ Analog inputs → Analog input 3 → Line width	Thin Thick	
Alarm	→ Analog inputs → Analog input 3 → Alarm	Off Activated	see Chapter 8.5.3 “Configuration - Analog inputs”, Page 75.

9 Configuration examples

9.3 Conductivity measurement

Setting up a measurement system

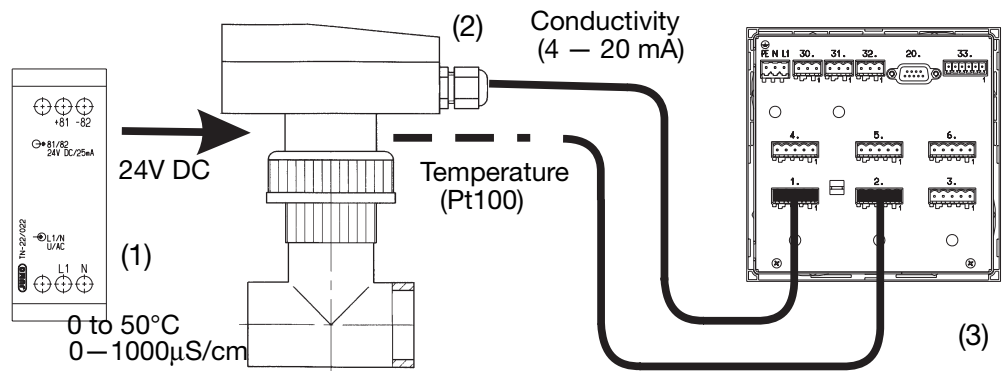

No.	Description	JUMO Data Sheet
(1)	PSU (e.g. PS5R-A-24)	
(2)	Conductivity transmitter with integrated temperature probe (e.g. JUMO CTI-Junior with extra code /263)	20.2754
(3)	LOGOSCREEN AQUA 500	20.2595

The conductivity measurement is dependent on temperature. Consequently, in this example, a conductivity transmitter (2) is used, which also measures the temperature by means of an integrated Pt100 sensor, in addition to the conductivity. The uncompensated conductivity is transmitted to the LOGOSCREEN AQUA 500 (3) via the standard 4 – 20 mA current signal. Temperature compensation takes place there.

The conductivity transmitter requires an auxiliary supply which is provided by the PSU (1). It is not possible to feed the conductivity transmitter from the auxiliary supply output of the LOGOSCREEN AQUA 500.

Settings



The example is based on the assumption that the conductivity transmitter is connected to input channel 5 of the LOGOSCREEN AQUA 500.

The temperature probe (Pt100 resistance thermometer) is connected to the input channel 4 of the LOGOSCREEN AQUA 500.

If you intend to use the temperature probe for temperature compensation of the conductivity, then this probe has to be configured first!

9 Configuration examples

Configuration of the temperature probe

Parameter	Configuration	Value / selection	Description
Temperature measurement on channel 4	→ Analog inputs → Analog input 4 → Measured variable	Temperature	see Chapter 8.5.3 “Configuration - Analog inputs”, Page 75.
Signal source	→ Analog inputs → Analog input 4 → Signal source	RTD	
Linearization	→ Analog inputs → Analog input 4 → Signal source → Linearization	Pt100	
Connection circuit	→ Analog inputs → Analog input 4 → Signal source → Connection circuit	2-wire or 3-wire or 4-wire	
Start temperature	→ Analog inputs → Analog input 4 → Signal source → Start temperature	0.0000°C (for example)	
End temperature	→ Analog inputs → Analog input 4 → Signal source → End temperature	50.000°C (for example)	
Channel name	→ Analog inputs → Analog input 4 → Channel name	Inp. 4 (variable text)	
Unit	→ Analog inputs → Analog input 4 → Unit	°C (variable text)	
Decimal place	→ Analog inputs → Analog input 4 → Decimal place	Automatic x.xxxx xx.xxx xxx.xx xxxx.x xxxxx.	
Line width	→ Analog inputs → Analog input 4 → Line width	Thin Thick	
Alarm	→ Analog inputs → Analog input 4 → Alarm	Off Activated	see Chapter 8.5.3 “Configuration - Analog inputs”, Page 75.

9 Configuration examples

Configuration of the conductivity input

Parameter	Configuration	Value / selection	Description
Measured variable	→ Analog inputs → Analog input 5 → Measured variable	Conductivity	
Dimensional unit	→ Analog inputs → Analog input 5 → Dimensional unit	μS/cm (or mS/cm) (transmitter data)	
Signal source	→ Analog inputs → Analog input 5 → Signal source	Tran.no-comp. (transmitter without compensation)	
Input signal	→ Analog inputs → Analog input 5 → Input signal	Current	
Range start	→ Analog inputs → Analog input 5 → Range start	4.0000 mA	
Range end	→ Analog inputs → Analog input 5 → Range end	20.000 mA	
Start of transmission range	→ Analog inputs → Analog input 5 → Transmission range start	0.0000 μS/cm (transmitter data)	
End of transmission range	→ Analog inputs → Analog input 5 → Transmission range end	1000.0 μS/cm (transmitter data)	
Compensation	→ Analog inputs → Analog input 5 → Compensation	Analog inp. 4 (or manual) Note: If “manual” has been selected in place of an analog input, the process temperature can be entered.	
Reference temperature	→ Analog inputs → Analog input 5 → Compensation → Reference temperature	25.000°C (usually: 18°C, 20°C or 25°C)	
Channel name	→ Analog inputs → Analog input 5 → Channel name	Inp. 5 (variable text)	
Unit	→ Analog inputs → Analog input 5 → Unit	μS/cm (variable text)	

9 Configuration examples

Parameter	Configuration	Value / selection	Description
Decimal place	→ Analog inputs → Analog input 5 → Decimal place	Automatic x.xxxx xx.xxx xxx.xx xxxx.x xxxxx.	
Line width	→ Analog inputs → Analog input 5 → Line width	Thin Thick	
Alarm	→ Analog inputs → Analog input 5 → Alarm	Off Activated	see Chapter 8.5.3 “Configuration - Analog inputs”, Page 75.

9 Configuration examples

9.4 Measurement of free chlorine

General

The measurement of free chlorine is dependent on pH and temperature.

⇒ JUMO Technical Publication “FAS 619, Information on the amperometric measurement of free chlorine, chlorine dioxide and ozone in water”.

The LOGOSCREEN AQUA 500 compensates for these effects.

The cell has to be calibrated at the working point. If the working point lies in the acid or neutral range, then the highest level of accuracy will be achieved.

Permissible ranges pH value: 6.5 to 8.5 pH

Temperature: 5 to 45°C

Calibration pH value	Process pH value	Accuracy	Measurement
7.0 – 7.2	-> 6.5 -> 8.0	very accurate	very accurate
8.0 – 8.5	-> 6.5	imprecise	not permissible
6.5	-> 7.8	very accurate	very accurate
6.5	-> 8.0 – 8.5	imprecise	just permissible

Setting up a measurement system

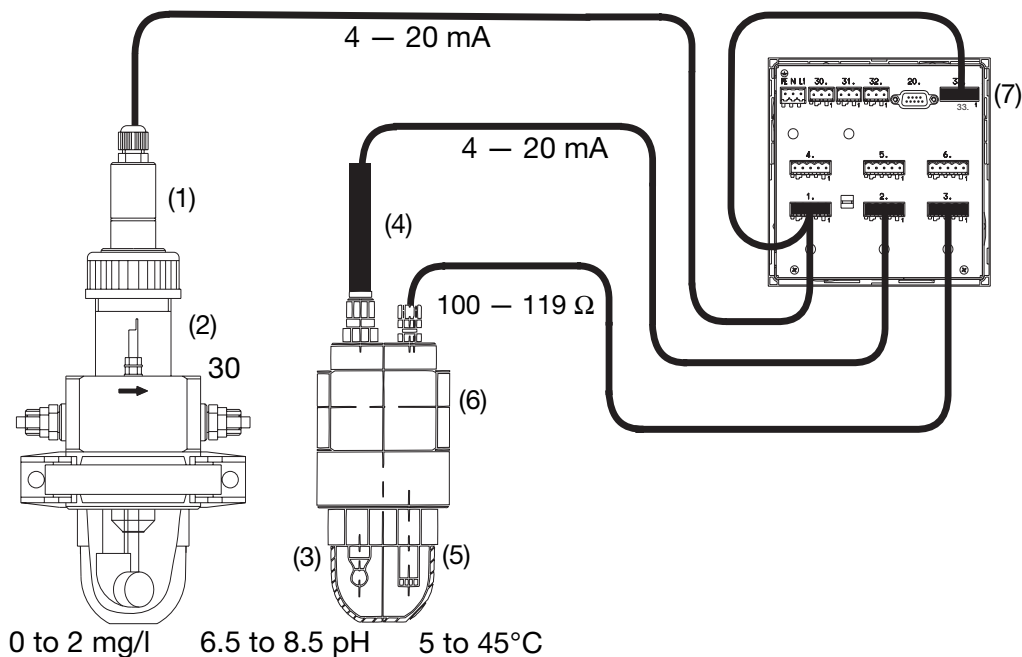

No.	Description	JUMO Data Sheet
(1)	Measuring cell for free chlorine, Type 202630/40	20.2630
(2)	Flow-through fitting, Type 202810/01-102-86-080/055	20.2630
(3)	pH combination electrode	20.2900
(4)	Impedance converter, Type 2AMZ-20	20.2995
(5)	Compensation thermometer, Type 2K-2	20.2900
(6)	Flow-through fitting, Type 202810/03-104-87-080/000	20.2810
(7)	LOGOSCREEN AQUA 500	20.2595

9 Configuration examples

The measuring cell for free chlorine (1) provides an **uncalibrated and uncompensated** signal (4 – 20 mA). It needs an auxiliary voltage for operation, which is supplied by the auxiliary voltage output of the LOGOSCREEN AQUA 500.

The flow-through fitting (2) enables the optimum flow of the sample liquid past the cell (1). The necessary minimum flow (≥ 30 liters/hr or 15 cm/sec) is ensured by the flow monitoring assembly (see Data Sheet 20.2630).

The pH combination electrode (3) with connected impedance converter (4) provides the pH signal that is necessary for the pH value compensation of the chlorine signal. The compensation thermometer (5) is needed for the temperature compensation of the chlorine signal.



The NTC built into the chlorine measuring cell only takes into account the temperature effects specific to the cell (e.g. permeability of the membrane for the substance being analyzed).

The LOGOSCREEN AQUA 500 (7) processes the signals of all the sensors connected.

Settings



If the temperature and the pH value for temperature/pH value compensation have to be measured via other channels, you have to configure the temperature channel first and then the pH value channel.



The example is based on the assumption that the measuring cell for free chlorine is connected to input channel 1 of the LOGOSCREEN AQUA 500. The pH value is measured on input channel 2. The temperature which is used for compensating the pH value and the chlorine concentration is measured via channel 3.

9 Configuration examples

Configuration of the temperature probe

Parameter	Configuration	Value / selection	Description
Temperature measurement on channel 3	→ Analog inputs → Analog input 3 → Measured variable	Temperature	see Chapter 8.5.3 “Configuration - Analog inputs”, Page 75.
Signal source	→ Analog inputs → Analog input 3 → Signal source	RTD	
Linearization	→ Analog inputs → Analog input 3 → Signal source → Linearization	Pt100	
Connection circuit	→ Analog inputs → Analog input 3 → Signal source → Connection circuit	2-wire or 3-wire or 4-wire	
Start temperature	→ Analog inputs → Analog input 3 → Signal source → Start temperature	0.0000°C (for example)	
End temperature	→ Analog inputs → Analog input 3 → Signal source → End temperature	50.000°C (for example)	
Channel name	→ Analog inputs → Analog input 3 → Channel name	Inp. 3 (variable text)	
Unit	→ Analog inputs → Analog input 3 → Unit	°C (variable text)	
Decimal place	→ Analog inputs → Analog input 3 → Decimal place	Automatic x.xxxx xx.xxx xxx.xx xxxx.x xxxxx.	
Line width	→ Analog inputs → Analog input 3 → Line width	Thin Thick	
Alarm	→ Analog inputs → Analog input 3 → Alarm	Off Activated	see Chapter 8.5.3 “Configuration - Analog inputs”, Page 75.

9 Configuration examples

Configuration of the pH input

Parameter	Configuration	Value / selection	Description
Measured variable	→ Analog inputs → Analog input 2 → Measured variable	pH value	
Signal source	→ Analog inputs → Analog input 2 → Signal source	Impedance converter	
Input signal	→ Analog inputs → Analog input 2 → Input signal	Voltage	
Range start	→ Analog inputs → Analog input 2 → Range start	-600.00 mV	
Range end	→ Analog inputs → Analog input 2 → Range end	+600.00 mV	
Temperature compensation	→ Analog inputs → Analog input 2 → Compensation → Temperature comp.	Analog inp.3 Analog input 3 can only be selected if it has already been configured as a temperature channel. Note: If "manual" has been selected in place of an analog input, the process temperature can be entered.	
Channel name	→ Analog inputs → Analog input 2 → Channel name	Inp. 2 (variable text)	
Unit	→ Analog inputs → Analog input 2 → Unit	pH (variable text)	
Scaling start	→ Analog inputs → Analog input 2 → Scaling start	6.5000 (scaling of the diagram representation)	Start value of the range within which the pH value is determined and displayed.
Scaling end	→ Analog inputs → Analog input 2 → Scaling end	9.0000 (scaling of the diagram representation)	End value of the range within which the pH value is determined and displayed.
Decimal place	→ Analog inputs → Analog input 2 → Decimal place	Automatic x.xxxx xx.xxx xxx.xx xxxx.x xxxxx.	

9 Configuration examples

Parameter	Configuration	Value / selection	Description
Line width	→ Analog inputs → Analog input 2 → Line width	Thin Thick	
Alarm	→ Analog inputs → Analog input 2 → Alarm	Off Activated	see Chapter 8.5.3 “Configuration - Analog inputs”, Page 75.

Configuration of the chlorine input

Parameter	Configuration	Value / selection	Description
Measured variable	→ Analog inputs → Analog input 1 → Measured variable	Chlorine	
Signal source	→ Analog inputs → Analog input 1 → Signal source	Tran.no-comp (transmitter without compensation)	
Input signal	→ Analog inputs → Analog input 1 → Input signal	Current	
Range start	→ Analog inputs → Analog input 1 → Range start	4.0000 mA	
Range end	→ Analog inputs → Analog input 1 → Range end	20.000 mA	
Start of transmission range	→ Analog inputs → Analog input 1 → Transmission range start	0.0000 mg/l (transmitter data)	
End of transmission range	→ Analog inputs → Analog input 1 → Transmission range end	2.0000 mg/l (transmitter data)	
Temperature compensation (temperature error)	→ Analog inputs → Analog input 1 → Compensation → Temperature comp.	Analog input 3 or manual (within range 5 to 45°C) Note: If “manual” has been selected instead of an analog input, the process temperature can be entered.	

9 Configuration examples

Parameter	Configuration	Value / selection	Description
pH value compensation (pH value error)	→ Analog inputs → Analog input 1 → Compensation → pH value comp.	Analog input 2 or manual (within range 6.5 to 8.5 pH; standard: 7.2 pH) Note: If “manual” has been selected instead of an analog input, the pH value can be entered.	
Channel name	→ Analog inputs → Analog input 1 → Channel name	Inp.1 (variable text)	
Unit	→ Analog inputs → Analog input 1 → Unit	mg/l (variable text)	
Decimal place	→ Analog inputs → Analog input 1 → Decimal place	Automatic x.xxxx xx.xxx xxx.xx xxxx.x xxxxx.	
Line width	→ Analog inputs → Analog input 1 → Line width	Thin Thick	
Alarm	→ Analog inputs → Analog input 1 → Alarm	Off Activated	see Chapter 8.5.3 “Configuration - Analog inputs”, Page 75.

9 Configuration examples

9.5 Measurement of chlorine dioxide / ozone

Setting up a measurement system

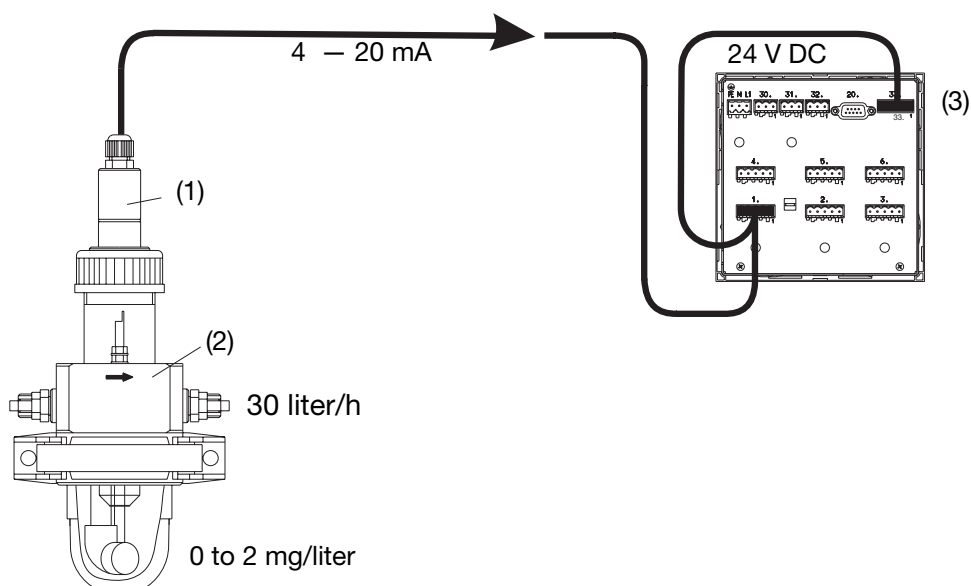

No.	Designation	JUMO Data Sheet
(1)	Measuring cell for chlorine dioxide, Type 202630/45 or measuring cell for ozone, Type 202630/50	20.2630
(2)	Flow-through fitting, Type 202810/01-102-86-080/055	20.2810
(3)	LOGOSCREEN AQUA 500	20.2595

In this example, a chlorine dioxide/ozone measuring cell (1) is connected directly to the LOGOSCREEN AQUA 500 (3) for measuring the chlorine dioxide/ozone concentration. It provides the standard 4 – 20 mA signal for processing.

The auxiliary voltage for the chlorine dioxide/ozone measuring cell is provided by the LOGOSCREEN AQUA 500.

The flow-through fitting (2) enables an optimum flow of the sample liquid past the cell (1). The necessary minimum flow (≥ 30 liters/h or 15 cm/sec) is ensured by the flow monitoring assembly (see Data Sheet 20.2630).

Settings



The example is based on the assumption that the measuring cell for chlorine dioxide/ozone is connected to input channel 1 of the LOGOSCREEN AQUA 500.

Temperature and/or pH compensation is not necessary when measuring chlorine dioxide/ozone!

9 Configuration examples

Configuration of the chlorine dioxide/ozone input

Parameter	Configuration	Value / selection	Description
Measured variable	→ Analog inputs → Analog input 1 → Measured variable	ClO ₂ (chlorine dioxide) or ozone	
Signal source	→ Analog inputs → Analog input 1 → Signal source	Tran. (transmitter)	
Input signal	→ Analog inputs → Analog input 1 → Input signal	Current	
Range start	→ Analog inputs → Analog input 1 → Range start	4.0000 mA	
Range end	→ Analog inputs → Analog input 1 → Range end	20.000 mA	
Start of transmission range	→ Analog inputs → Analog input 1 → Transmission range start	0.0000 mg/l	
End of transmission range	→ Analog inputs → Analog input 1 → Transmission range end	2.0000 mg/l	
Channel name	→ Analog inputs → Analog input 1 → Channel name	Inp.1 (variable text)	
Unit	→ Analog inputs → Analog input 1 → Unit	mg/l (variable text)	
Decimal place	→ Analog inputs → Analog input 1 → Decimal place	Automatic x.xxxx xx.xxx xxx.xx xxxx.x xxxxx.	
Line width	→ Analog inputs → Analog input 1 → Line width	Thin Thick	
Alarm	→ Analog inputs → Analog input 1 → Alarm	Off Activated	see Chapter 8.5.3 "Configuration - Analog inputs", Page 75.

9 Configuration examples

9.6 Concentration measurement of sulfuric acid (H₂SO₄)

Setting up a measurement system

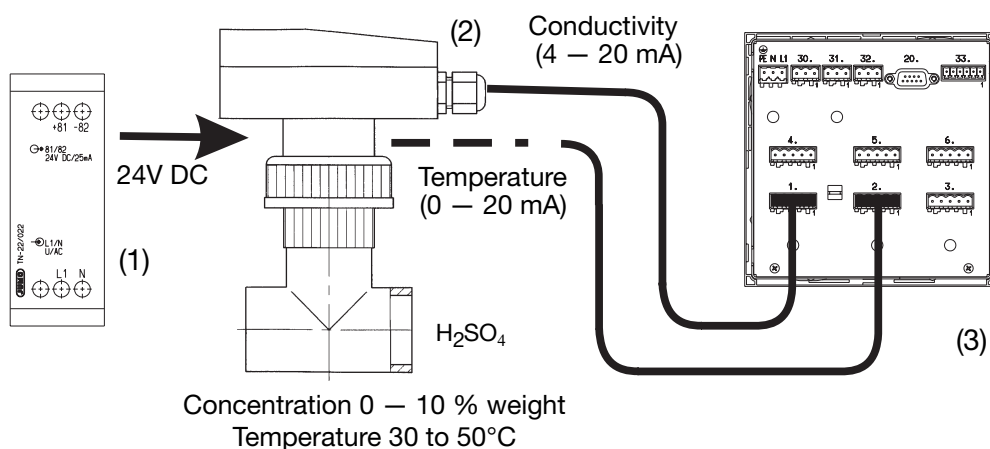

No.	Designation	JUMO Data Sheet
(1)	PSU (e.g. PS5R-A-24)	
(2)	Conductivity transmitter (e.g. JUMO CTI-920 without temperature compensation)	20.2752
(3)	LOGOSCREEN AQUA 500	20.2595

The LOGOSCREEN AQUA 500 (3) can determine the sulfuric acid concentration if the uncompensated conductivity and the temperature of the medium is known. In the example, a conductivity transmitter (2) is connected to the LOGOSCREEN AQUA 500 (3). It can measure the conductivity and the temperature of the medium and transmits both values to the LOGOSCREEN AQUA 500 via standard signals. Temperature compensation takes place in the LOGOSCREEN AQUA 500.

The conductivity transmitter (2) is fed by a PSU (1).

Task (example):

In the example, the concentration of sulfuric acid (H₂SO₄) has to be measured within the range of 0 – 10 % weight, at a temperature of approx. 30 to 50°C.

Settings



The example is based on the assumption that the conductivity transmitter is connected to input channel 5 of the LOGOSCREEN AQUA 500.

The temperature output of the conductivity transmitter is connected to input channel 4 of the LOGOSCREEN AQUA 500.

Since the temperature probe is intended to be used for temperature compensation of the concentration, this probe has to be configured first!

If the conductivity transmitter is equipped with a temperature compensation facility, the latter must be switched off (set to 0%/°C).

9 Configuration examples

Configuration of the temperature probe

Parameter	Configuration	Value / selection	Description
Temperature measurement on channel 4	→ Analog inputs → Analog input 4 → Measured variable	Temperature	see Chapter 8.5.3 “Configuration - Analog inputs”, Page 75.
Signal source	→ Analog inputs → Analog input 4 → Signal source	Tran.+lin. (transmitter with linearization)	
Linearization	→ Analog inputs → Analog input 4 → Signal source → Input signal	Current	
Range start	→ Analog inputs → Analog input 4 → Signal source → Range start	4.0000 mA (data for the temperature output of the CTI-920)	
Range end	→ Analog inputs → Analog input 4 → Signal source → Range end	20.000 mA (data for the temperature output of the CTI-920)	
Start of transmission range	→ Analog inputs → Analog input 4 → Transmission range start	0.0000°C (data for the temperature probe of the CTI-920)	
End of transmission range	→ Analog inputs → Analog input 4 → Transmission range end	150.00°C (data for the temperature probe of the CTI-920)	
Filter constant	→ Analog inputs → Analog input 4 → Filter constant	0.1000 s	
Channel name	→ Analog inputs → Analog input 4 → Channel name	Inp. 4 (variable text)	
Unit	→ Analog inputs → Analog input 4 → Unit	°C (variable text)	
Decimal place	→ Analog inputs → Analog input 4 → Decimal place	Automatic x.xxxx xx.xxx xxx.xx xxxx.x xxxxx.	
Line width	→ Analog inputs → Analog input 4 → Line width	Thin Thick	

9 Configuration examples

Parameter	Configuration	Value / selection	Description
Alarm	→ Analog inputs → Analog input 4 → Alarm	Off Activated	see Chapter 8.5.3 “Configuration - Analog inputs”, Page 75.

Configuration of the concentration input

Parameter	Configuration	Value / selection	Description
Measured variable	→ Analog inputs → Analog input 5 → Measured variable	Sulf. acid (sulfuric acid)	
Range	→ Analog inputs → Analog input 5 → Range	Range I (0 – 28%)	see Chapter 3.1 “Analog inputs”, Page 14.
Signal source	→ Analog inputs → Analog input 5 → Signal source	Tran.no-comp. (transmitter without compensation)	
Input signal	→ Analog inputs → Analog input 5 → Input signal	Current	
Range start	→ Analog inputs → Analog input 5 → Range start	4.0000 mA (data for the transmitter output)	
Range end	→ Analog inputs → Analog input 5 → Range end	20.000 mA (data for the transmitter output)	
Start of transmission range	→ Analog inputs → Analog input 5 → Transmission range start	0.0000 mS/cm (transmitter data)	
End of transmission range	→ Analog inputs → Analog input 5 → Transmission range end	2000.0 mS/cm (transmitter data)	
Filter constant	→ Analog inputs → Analog input 5 → Filter constant	0.1000 s	
Temperature compensation	→ Analog inputs → Analog input 5 → Compensation → Temperature comp.	Analog inp.4 Note: the temperature output of the CTI- 920 is at analog input 4).	
Channel name	→ Analog inputs → Analog input 5 → Channel name	Inp. 5 (variable text)	

9 Configuration examples

Parameter	Configuration	Value / selection	Description
Unit	→ Analog inputs → Analog input 5 → Unit	% weight (variable text)	
Scaling start	→ Analog inputs → Analog input 5 → Scaling start	0.0000 % weight (scaling of the diagram representation)	Value range depends on the configured range (I, II or III)
Scaling end	→ Analog inputs → Analog input 5 → Scaling end	10.000 % weight (scaling of the diagram representation)	see Chapter 3.1 “Analog inputs”, Page 14.
Decimal place	→ Analog inputs → Analog input 5 → Decimal place	Automatic x.xxxx xx.xxx xxx.xx xxxx.x xxxxx.	
Line width	→ Analog inputs → Analog input 5 → Line width	Thin Thick	
Alarm	→ Analog inputs → Analog input 5 → Alarm	Off Activated	see Chapter 8.5.3 “Configuration - Analog inputs”, Page 75.

10 Service & calibration

Service & calibration menu

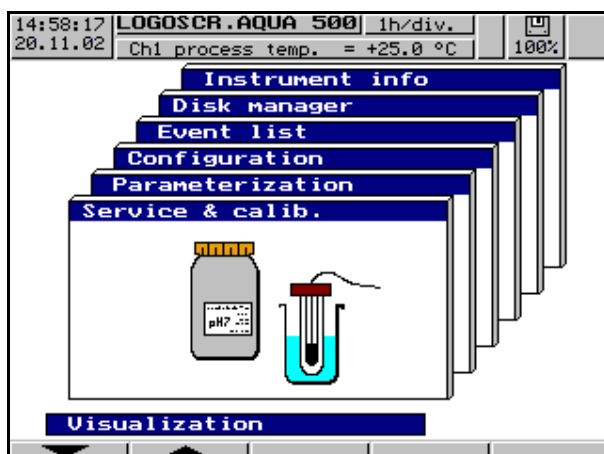

You can calibrate the connected sensors (electrodes and measuring cells) from this menu.

10.1 Entry of code number for the Service & calibration menu

This menu is protected

The Service and calibration menu can be protected by a code number. If an incorrect code number is entered, then only the logbook can be viewed.

Unlocking

- * Call up the Service & calibration menu
- * Press ENTER
- * Enter code number (in basic status: 09200)
- * Press ENTER

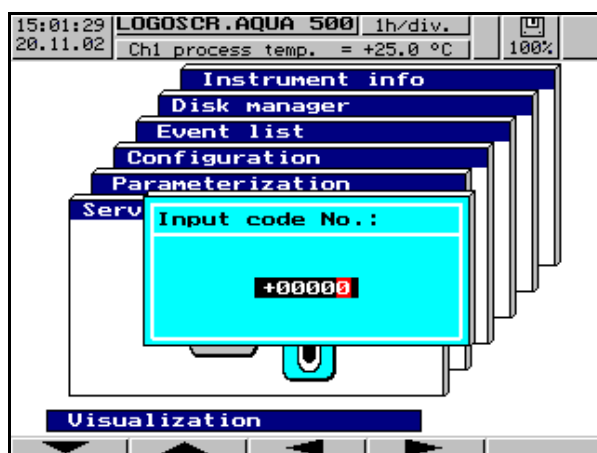

10.2 General

The submenu shown below is available for each analog input:

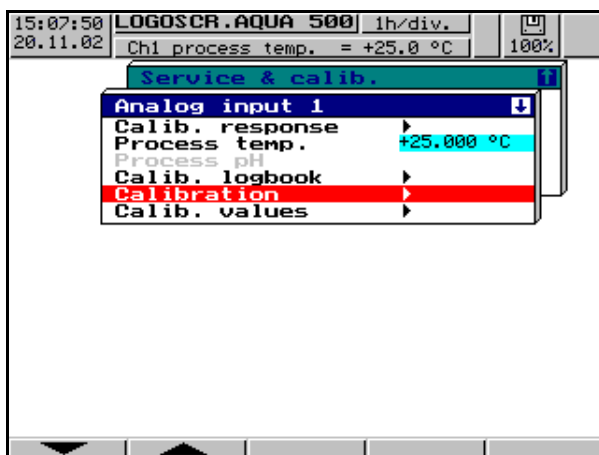

- There is the option of modifying the process temperature and process pH value outside the configuration for all channels with manual compensation, thus adapting them to the actual requirements of the process. The modified process values are entered in the event list, see Chapter 7.6 “Event list”, Page 57.
- The calibration parameters for the electrode and measuring cell calibration are set once, ready to be reused at the next calibration.
- The calibration results are entered in the logbook.
- If you do not wish to log the measurements and alarms **during** calibration, all channels, in particular the calibration channel and, if required, also the channels used for temperature and pH compensation, can be frozen. The measurements and alarms are held at the last value acquired before calibration.
The freezing of measurements and alarms can be stopped after calibration by modifying the parameter “Calibration response”, or automatically terminated on exiting from the Service & calibration menu.
- Entries and modifications which are performed in the Service & calibration menu, do **not** result in loss of data. All data acquired up to this point are retained and can be uploaded. The data can be retraced on the instrument using the *History* function and evaluated and archived by means of the optional PC evaluation software.
- On leaving the Service & calibration menu, the data acquired (zero point, slope etc.) are saved to the FLASH memory. No current data are processed by the analog inputs during this brief action and the relays (if available) move to the neutral position (as in the de-energized state).

10 Service & calibration



- Entries or modifications performed in the *Service & calibration* menu do **not** lead to reconfiguration and **not** to the loss of recently acquired data.
 - After calibration has been performed and calibration values have been modified, the LOGOSCREEN AQUA 500 is restarted after leaving the *Service & calibration* menu.
 - Depending on the process variable selected in the *Configuration* menu, not all of the parameters described below are available.
-

10.3 Response to calibration

Defining the measurement response during calibration

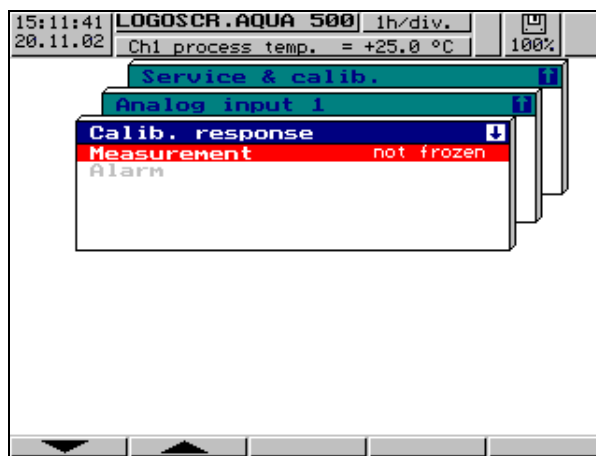

- * Determine whether measurements are to be “frozen” or “not frozen” during calibration (HOLD function).
 - ⇒ “→ Measurement”, Page 124.

Freeze measurement:

The measurement before “freezing” is held and continues to be recorded. Measurement variations that occur during the “frozen” state are not recorded.

Do not freeze measurement:

All measurement variations are recorded and can be called up later on.

Start of function:

- Start calibration of one channel
- Reprogram one calibration value

End of function:

- Exit from the *Service & calibration* menu
- Reprogram parameter from “Freeze measurement” to “Do not freeze measurement”



The measurement data will deviate from the process data during calibration (because of sensor cleaning, buffer solutions, temperature changes etc.).

Please note during calibration that, apart from the channel to be calibrated, also other input channels (e.g. channel for temperature compensation) may be affected by these deviations.

It may make sense to “freeze” the channel to be calibrated as well as all the affected channels.

Defining the alarm response during calibration

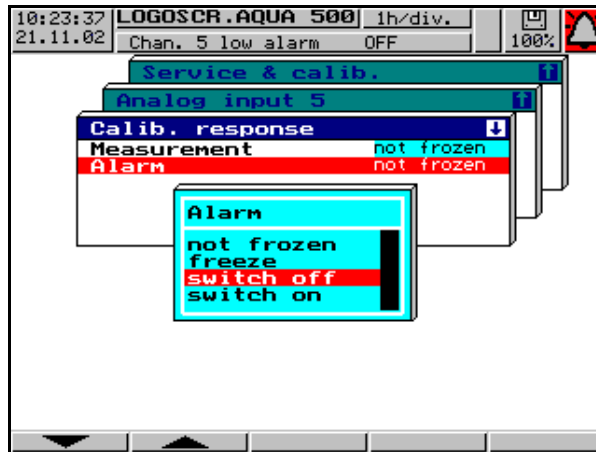

Determine whether alarms (with configured limit monitoring) are to be “frozen”, “not frozen” or are defined as being “switched on” or “switched off” (HOLD function).

Freeze alarm:

The alarm state before “freezing” is held and continues to be recorded.

Do not freeze alarm: Limit infringements trigger alarms if limit monitoring has been programmed.

Start of function:

- Start calibration of one channel
- Reprogram one calibration value

End of function:

- Exit from the *Service & calibration* menu
- Reprogram parameter from “Freeze alarm”, “Switch alarm on” or “Switch alarm off” to “Do not freeze alarm”



The measurement data will deviate from the process data during calibration (because of sensor cleaning, buffer solutions, temperature changes etc.).

Please note during calibration that, apart from the channel to be calibrated, also other input channels (e.g. channel for temperature compensation) may be affected by these deviations.

It may make sense to define the alarm response for the channel to be calibrated **as well as** for all the affected channels.

10 Service & calibration

Marking the calibration procedure in the recorded data

The electrode calibration can be read from the data for measurement interpretation:

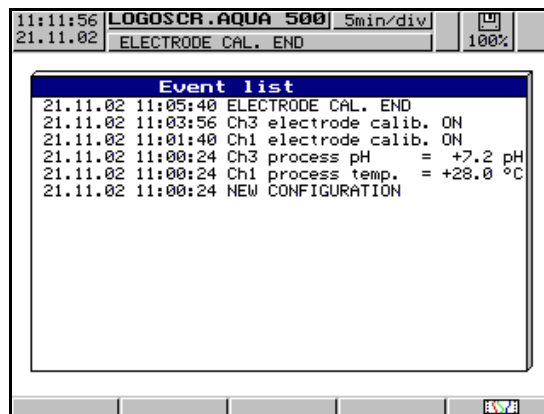

The start of the first calibration is entered in the event list for each channel. The end of the calibration is recorded on leaving the *Service & calibration* menu, see Chapter 7.6 “Event list”, Page 57.

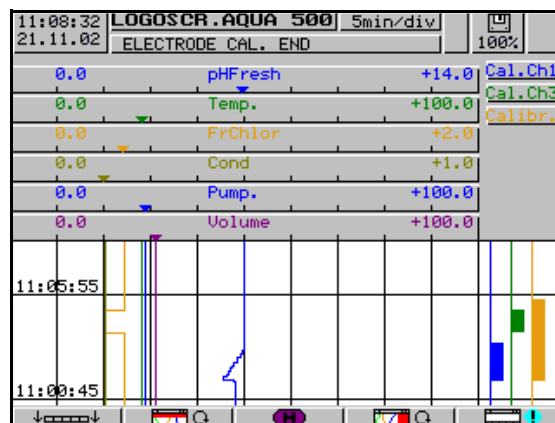

With the appropriate configuration, it is possible to record on the event traces:

- Active calibration of one channel (signal: “Electrode calibration channel x”)
- Calibration status for instrument (from the time of entering into the calibration or the modification of a calibration value of a channel to exiting from the *Service & calibration* menu)

You can see in the logbook from which instant of time the new calibration values were used.

10.4 Logbook

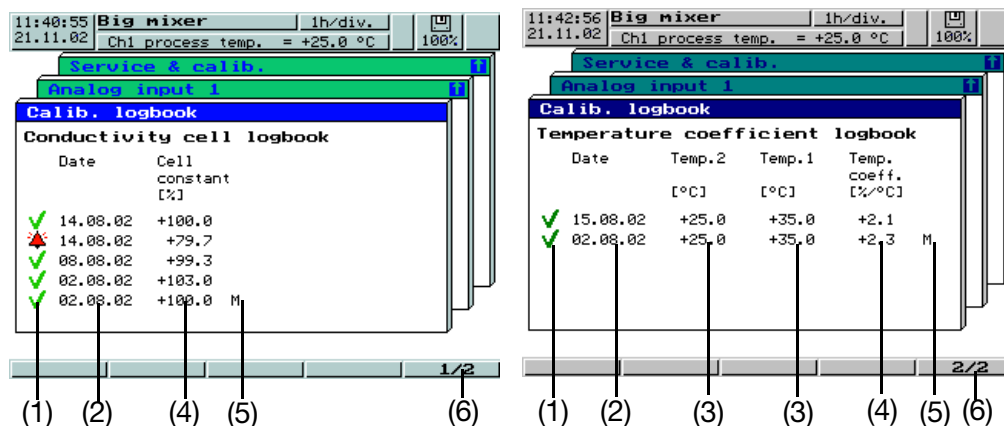

A logbook is kept for each channel which has an electrode or measuring cell that can be calibrated.



	Explanation
(1)	Evaluation of the calibration value
(2)	Date of calibration/manual input
(3)	Ambient conditions during calibration
(4)	Calibration values
(5)	The following manual adjustments are marked by "M": <ul style="list-style-type: none"> - Preselection of the calibration values after reconfiguration - Manual input of a calibration value - Switching the calibration procedure from 3-point to 2-point or 1-point calibration (for pH) - Reconstruction of the last logbook entry after a loss of data, see Chapter 7.8 "Instrument info", Page 64.
(6)	Softkey "Change between cell constant and temperature coefficient logbook" (only for conductivity measurement)





10 Service & calibration

Evaluation of the calibration values

Symbol	Evaluation
 ¹	Electrode/measuring cell/calibration result is OK
 ¹	Pre-alarm (e.g. DIN limit values have been exceeded) clean or replace electrode/measuring cell, if necessary.
 ²	Calibration unsuccessful. Possible causes: <ul style="list-style-type: none"> - Limits have been exceeded, clean or replace electrode/measuring cell, if necessary - Faulty input signal (e.g. electrode not connected, probe break) - Calibration temperature outside the permissible range - Calibration pH value outside the permissible range (only for calibration of a chlorine cell)
¹	No evaluation

¹ Calibration values can be accepted

² Calibration values cannot be accepted

Calibration value						Dimension
pH zero	< 5	5 –	6.5 – 7.5	– 9	> 9	pH
pH slope	< 75	75 –	89.6 – 100.6	– 110	> 110	%
Redox zero	< -2000	-2000 to < -200	no evaluation	> 200 – 2000	> 2000	mV
Cell constant	< 20	20 –	80 – 120	– 300	> 300	%
Temperature coefficient	< 0	--	0 – 5.5	--	> 5.5	%/°C
Sensitivity	no evaluation					%



Caution:

After reconfiguration:

- the calibration parameters and calibration values will be reset to the default values!
- the logbooks are deleted and initialized with the default values (preset)!

The data can be backed up on diskette **beforehand**, by using the disk manager.



Tip:

The calibration values and logbooks can be retained, if minor changes **that do not affect the analog inputs** and their electrodes or measuring cells are made in the configuration **from the instrument keys**.

Minor changes include, for example: setting the time, alteration of code numbers, changes to the text.

10.5 Calibration parameters

Depending on the electrode/measuring cell and the selected calibration procedure, the parameters for the subsequent calibration are specified here (e.g. the buffer used).

The settings are stored in the instrument and can be reused at the next calibration.

Calibration procedure

The calibration procedure is selected according to the electrode or measuring cell to be calibrated.

With **pH electrode calibration**, the number of calibration points and thus of the buffer solutions required is determined.

Calibration procedure	Reference values	Calibration values
1-point calibration	1 buffer solution	zero point
2-point calibration	2 buffer solutions	zero point, slope
3-point calibration	3 buffer solutions	zero point, slope, acidic, slope, alkaline



If the calibration procedure is reprogrammed from 3-point to 2-point or 1-point calibration, the alkaline slope is set to the value for the acidic slope.

With **conductivity measurement**, the following calibration procedures can be selected:

- Cell constant of the conductivity cell
- Temperature coefficient of the measurement solution

Calibration mode

Manual:

- possible for all calibration procedures
- The operator monitors the measurements during the calibration step and switches on to the next calibration step when the measurements are stable by using the ENTER key.

Semi-automatic:

- only possible for calibration of pH electrodes
- The operator prepares the calibration measurement and starts it by using the ENTER key.

10 Service & calibration

The instrument monitors the measurements and automatically switches on to the next calibration step when the measurements are stable.

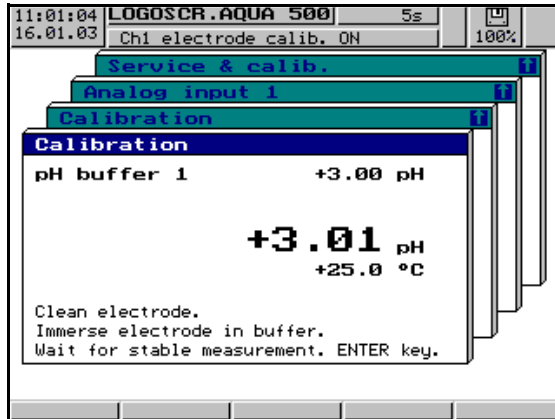

Calibration measurement is being prepared

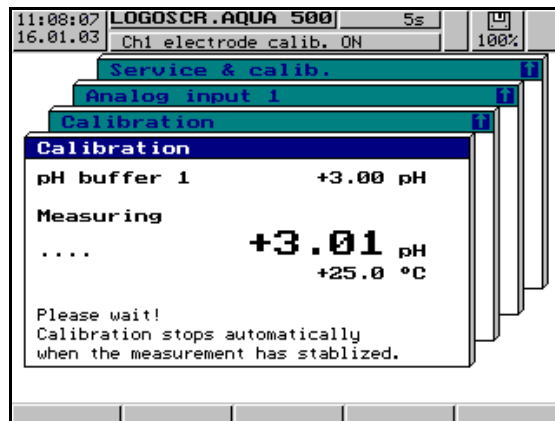

Calibration measurement was started.
Instrument is checking the measurement stability.

Calibration temperature

Acquisition of the process temperature	Acquisition of the calibration temperature
manual	manual ¹
Analog input x	manual ¹ or analog input x

¹ In this case, it is necessary to enter the calibration temperature before calibrating.

10 Service & calibration

Calibration pH value

Only for measurement of free chlorine:

Acquisition of the process pH value	Acquisition of the calibration pH value
manual	manual ¹
Analog input x	manual ¹ or analog input x

¹ In this case, it is necessary to enter the calibration pH value before calibrating.

Reference values

Depending on the calibration procedure, the corresponding reference values have to be entered before calibration:

- pH buffer 1
 - pH buffer 2
 - pH buffer 3
 - Redox buffer
 - DPD reference concentration
 - Reference conductivity
 - Temperature 1 (close to reference temperature)
 - Temperature 2 (close to operating temperature)
-

10 Service & calibration

10.6 Calibration

Calibration window

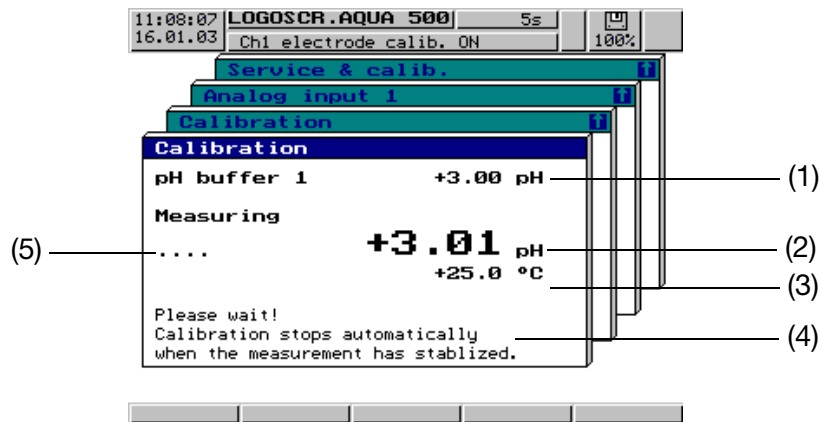

(1)	Display of reference value (buffer, reference conductivity, reference concentration, target temperature)
(2)	Display of uncompensated measurement (large)
(3)	Display of ambient conditions (calibration temperature, calibration pH value) - Large: for measurement of ambient conditions via a different channel. - Small: for manual input of the ambient conditions before calibration.
(4)	Help text with notes on the next calibration steps.
(5)	Display: "Calibration is running" (for pH electrode calibration in semi-automatic calibration mode).

Calibration report

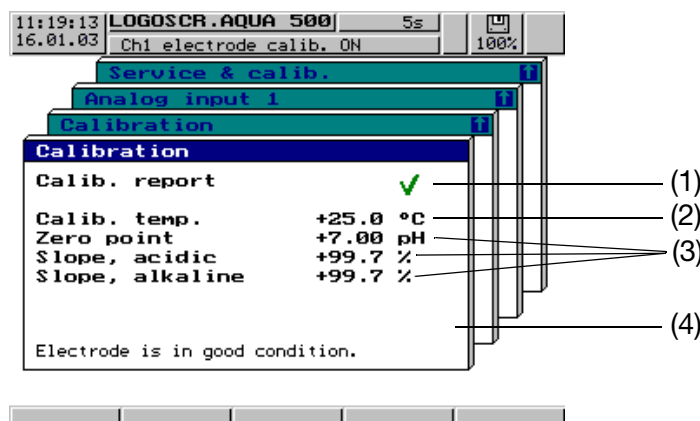

(1)	Symbol for evaluation see Chapter 10.4 "Logbook", Page 117.
(2)	Ambient conditions
(3)	Calibration values
(4)	Help text for evaluating the calibration result

Accepting the calibration values

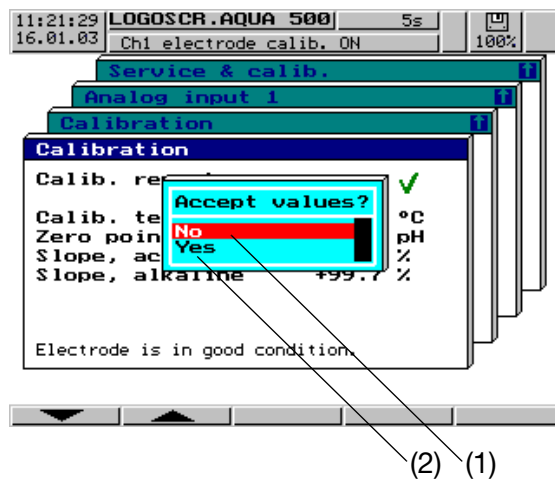

(1)	No:	Do not accept the new calibration values. The instrument continues operation with the old calibration values.
(2)	Yes:	Accept the new calibration values. After pressing the ENTER key, the instrument continues operation with the new calibration values.

10 Service & calibration

10.7 Table of service and calibration parameters

Parameter	Configuration	Value / selection	Description
Measurement	→ Analog inputs 1 – 6 → Calib. response → Measurement	not frozen (do not freeze)	The current measurements, as measured during calibration, are recorded.
		freeze	The value that was most recent when calibration was started keeps on being recorded continuously until the parameter is reprogrammed to “not frozen” or the <i>Service & calibration</i> menu is left.
Alarm	→ Analog inputs 1 – 6 → Calib. response → Alarm	not frozen	The measurements are monitored for the observance of limits, also during calibration.
		freeze	The alarms that were determined before calibration are kept frozen until the parameter is reprogrammed or the <i>Service & calibration</i> menu is left.
		switch off	The alarms are defined and set during calibration until the parameter is reprogrammed or the <i>Service & calibration</i> menu is left.
		switch on	
Process temperature	→ Analog input 1 – 6 → Process temperature	-50 to 250°C (depending on measurement variable)	only for measurements with manual temperature compensation
Process pH	→ Analog input 1 – 6 → Process pH	6.5 to 8.5 pH	only for measurements of free chlorine with manual pH value compensation
Calibration logbook	→ Analog input 1 – 6 → Calib. logbook		Calling up the calibration logbook for the electrode or measuring cell connected to the appropriate channel.
Calibration	→ Analog input 1 – 6 → Calibration → Calibration		Performing calibration proper, see Chapter 10.6 “Calibration”, Page 122.

10 Service & calibration

Parameter	Configuration	Value / selection	Description
Calibration procedure	→ Analog input 1 – 6 → Calibration → Calib.procedure	Settings that can be selected according to the measurement variable	
		1-point cal.	for pH: calibration of the electrode zero. The electrode slope remains constant.
		2-point cal.	for pH: calibration of electrode zero and slope.
		3-point cal.	for pH: calibration of electrode zero, electrode slope in the acidic and electrode slope in the alkaline range. Caution: When the calibration procedure is reprogrammed from 3-point to 2-point or 1-point calibration, the alkaline slope is set to the value of the acidic slope.
		Redox zero	for redox: calibration of the electrode zero.
		Cell const.	calibration of the cell constant of the conductivity cell for: measurement of conductivity, high-purity water, concentration
		Temp. coeff.	Calibration of the temperature coefficient of the solution for: conductivity
		Sensitivity	calibration of the sensitivity of the measuring cell for: free chlorine, chlorine dioxide, ozone
Calibration temperature	→ Analog input 1 – 6 → Calibration → Calib.temperature	manual	
		Analog inp. x	Via the same channel x which is used for measuring the process temperature.
Manual calibration temperature	→ Analog input 1 – 6 → Calibration → Man. calib. temp.	-50 to 250°C (depending on measurement variable)	If “manual” has been selected under “Calibration temperature”, you can enter the temperature value here. Not for conductivity measurement!

10 Service & calibration

Parameter	Configuration	Value / selection	Description
Temp. 1 close to the reference temperature	→ Analog input 1 – 6 → Calibration → Temp.1→Ref. temp.	-50 to 250°C	For conductivity and calibration procedure “Temperature coefficient”. The value for “Temp.1 → Ref. temp.” should be as close as possible to the reference temperature, see Chapter 8.5.3 “Configuration - Analog inputs”, Page 75.
Temp. 2 close to the operating temperature	→ Analog input 1 – 6 → Calibration → Temp. 2→Op. temp.	-50 to 250°C	For conductivity and calibration procedure “Temperature coefficient”. The value for “Temp.2 → op. temp.” should be as close as possible to the later operating temperature.
Calibration step 1	→ Analog input 1 – 6 → Calibration → Calib. step 1	Temp. 1 Temp. 2	For conductivity and calibration procedure “Temperature coefficient”. Determine here which temperature is to be reached first.
Calibration pH	→ Analog input 1 – 6 → Calibration → Calib. pH	for “free chlorine”:	
		manual	
		Analog input x	Via the same channel x which is used for measuring the process pH.
Manual calib. pH	→ Analog input 1 – 6 → Calibration → Man.calib. pH	6.5 to 8.5 pH	Can only be selected if “Chlorine” has been selected under “Measured variable”. Input option, if “Manual” has been selected in the previous setting.
Calibration mode	→ Analog input 1 – 6 → Calibration → Calib. mode	for “pH value”:	
		manual	The user decides here when a stable reading was achieved.
		semi-automatic	In this mode, the instrument decides when a stable measurement was achieved.
pH buffer 1	→ Analog input 1 – 6 → Calibration → pH buffer 1	-1 to 14 pH	for “pH value”: pH value of the first buffer to be used with calibration temperature.



10 Service & calibration

Parameter	Configuration	Value / selection	Description
pH buffer 2	→ Analog input 1 – 6 → Calibration → pH buffer 2	-1 to 14 pH	For “pH value” and “2-point cal.” and “3-point cal.” calibration procedures: pH of the second buffer to be used with calibration temperature, which differs from the first buffer solution by at least 2 pH.
pH buffer 3	→ Analog input 1 – 6 → Calibration → pH buffer 3	-1 to 14 pH	For “pH value” and “3-point cal.” calibration procedures: pH value of the third buffer to be used with calibration temperature. One of the three buffers should have a pH close to pH 7. The buffers should differ by at least 2 pH in each case.
Redox buffer	→ Analog input 1 – 6 → Calibration → Redox buffer	-2000 to 2000 mV	for “Redox”
DPD reference concentration	→ Analog input 1 – 6 → Calibration → DPD ref. concent.	0 to 20 mg/liter	For “Free chlorine”, “Chlorine dioxide” and “Ozone”: Here you enter the concentration which was determined from a sample of the medium using the DPD method or another suitable reference method.
Reference conductivity	→ Analog input 1 – 6 → Calibration → Ref. conductivity	Conductivity: 0 – 99999 μ S/cm or 0 – 2000 mS/cm High-purity water: 0 – 10 μ S/cm Concentration measurement: 0 – 2000 mS/cm	For conductivity, high-purity water and concentration and “Cell const.” calibration procedure: Here you have to enter the value of the reference solution or the conductivity of the uncompensated comparison measurement.







10 Service & calibration

Parameter	Configuration	Value / selection	Description
Calibration values			
Here you can enter the calibration values for the electrodes and measuring cells, for example when they have been measured in the laboratory and are already known. The modification of calibration values outside the calibration is marked by "M" in the calibration logbook.			
Zero point	→ Analog input 1 – 6 → Calib. values → Zero point	5... 6.5...7.5 ...9	for pH
Slope, acidic	→ Analog input 1 – 6 → Calib. values → Slope acidic	75... 89.6...100.6 ...110	for pH
Slope, alkaline	→ Analog input 1 – 6 → Calib. values → Slope alkaline	75... 89.6...100.6 ...110	for pH, only with 3-point calib.
Redox zero	→ Analog input 1 – 6 → Calib. values → Redox zero	-2000... -200...200 ...2000	for redox:
Relative cell constant	→ Analog input 1 – 6 → Calib. values → Rel. cell const.	20... -80...120 ...300	for conductivity, high-purity water or concentration and "Cell const." calibration procedure
Temperature coefficient	→ Analog input 1 – 6 → Calib. values → Temp. coefficient	0...5.5	for conductivity and "Temp. coeff." calibration procedure.
Sensitivity	→ Analog input 1 – 6 → Calib. values → Sensitivity	-99999...99999	with chlorine dioxide or ozone The measuring cell has to be calibrated when measuring free chlorine.







11.1 Start

- * Press the MENU key
- * Use the softkeys  or  to select the "Service & calibration" menu and confirm with ENTER.

Response to calibration

- * Use the softkeys  or  to select the analog input that has been affected by the calibration and confirm with ENTER.
- * Use the ENTER key to select "Calib. response" and confirm with ENTER.
- * Use the softkeys  or  to select "Measurement" or "Alarm", then press ENTER.
- * Use the softkeys  or  to select the response "not frozen" or "freeze" (with "Alarm": additionally "switch off" or "switch on", if required) and confirm with the ENTER key.
Change over to the "Analog input x" menu by pressing the EXIT key.
- * Possibly define "Response to calibration" for other analog inputs.

Calibration

- * Use the softkeys  or  to select the analog input which needs to be calibrated and confirm with ENTER.
- * Use the softkeys  or  to select the menu item "Calibration" and confirm with ENTER.
- * If required, set the calibration parameters, e.g. "Calib.procedure", "Calib.temp.", pH buffer 1 to 3, etc. (operation in the same way as for the previous steps).
- * Use the softkeys  or  to select the menu item "Calibration" and confirm with ENTER.
- * Carry out operational steps according to the instructions on the display. A report is displayed for both successful and unsuccessful operation.
- * Confirm report with the ENTER key.
- * Decide with "Accept values" -> "No" or "Yes" if the calibration data are entered into the calibration logbook.
 - No: The values are discarded. The instrument continues to operate with the last values that were valid.
 - Yes: The values that were freshly determined are entered into the logbook. The instrument operates with the new values.
- * Confirm with the ENTER key.
- * Repeat calibration of this analog input or calibrate a different analog input or cancel/ quit using the EXIT key.

Response to calibration

If required, reset "Calibration response" for measurements and alarms for the analog inputs concerned to "not frozen" (see above).

11 Calibration



Entries or modifications performed in the *Service & calibration* menu do **not** lead to reconfiguration and **not** to the loss of recently acquired data.

On leaving the *Service & calibration* menu, the data acquired (zero point, slope etc.) can be saved to the FLASH memory. No current data are processed by the analog inputs during this brief action and the relays (if available) move to the neutral position (as in the de-energized state).

11.2 Calibrating pH electrodes

11.2.1 Basics

Calibration options

The electrode parameters of a pH combination electrode are subject to manufacturing tolerances and variations depending on usage. To compensate for these changing electrode parameters, the LOGOSCREEN AQUA 500 offers three calibration procedures:

1-point calibration

In 1-point calibration, **only the electrode zero** is freshly determined, by using a buffer solution (solution with a known pH, diverging at least 1 pH step from pH 7).

Problems arising from a faulty electrode slope will not be noticed by the user! This method should only be adopted in cases where the electrode is not subject to significant chemical and mechanical influences.

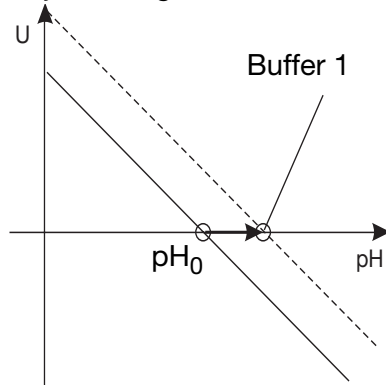

1-point calibration

11 Calibration

2-point calibration

2-point calibration makes a fresh determination of the **electrode zero and slope** using two buffer solutions. The values for “Slope, alkaline” and “Slope, acidic” are identical.

This method should be given preference!

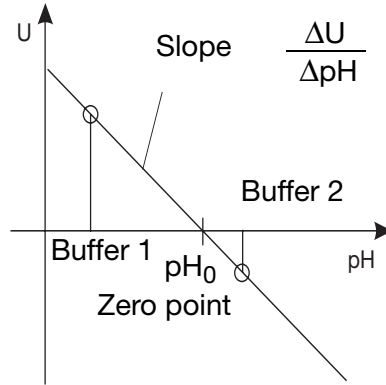

The order in which the buffers are used can be freely selected

2-point calibration

3-point calibration

In 3-point calibration, **the electrode zero and slopes** (acidic and alkaline) are freshly determined using three buffer solutions.

One of the buffer solutions must have a pH value close to pH 7.



On changing from 3-point calibration to 2-point or 1-point calibration, the calibration value “Slope, alkaline” is set to the value for “Slope, acidic.”

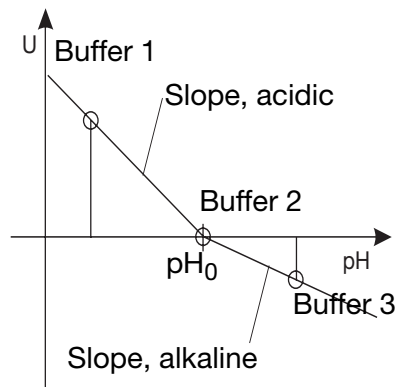

The order in which the buffers are used can be freely selected

3-point calibration

Manual entry of the calibration values

In addition to the calibration procedures described above, the LOGOSCREEN AQUA 500 offers the facility of manually entering “Zero point”, “Slope, acidic” and “Slope, alkaline” (as determined by a laboratory, for example).

Calibration value				Dimension
pH zero	5 —	6.5 — 7.5	— 9	pH
pH slope	75 —	89.6 — 100.6	— 110	%

11 Calibration

Temperature The measurement of the pH value depends on temperature; the temperature of the buffer solution must therefore be known when calibrating. The buffer solutions must be at the same temperature. The temperature can be measured either automatically via the same channel as used for measuring the process temperature, (e.g. with a Pt100 temperature probe), or it has to be set manually by the user.

Buffer The temperature dependence of the pH value must be taken into account by the operator when specifying the buffer to be used (observe the manufacturer's details on the bottles of the buffer solutions).

Example:

pH value of buffer solutions, dependent on the calibration temperature:

	Calibration temperature = 20°C	Calibration temperature = 25°C
pH value buffer 1	3.07 pH	3.06 pH
pH value buffer 2	6.80 pH	6.79 pH
pH value buffer 3	9.27 pH	9.23 pH

Cancel By pressing the EXIT key (repeatedly, if necessary) you can change back to the measurement mode at any time.

11.2.2 Calibrating a pH combination electrode (2-point calibration)

You will need

- two buffer solutions with pH values which roughly correspond to the medium to be measured later and which are at the same temperature.
- a thermometer, since temperature compensation is performed manually in this example.

Selecting the "Service & calibration" menu

- * Select the "Service & calib." menu and unlock, if necessary (code word 09200), see Chapter 10.1 "Entry of code number for the Service & calibration menu", Page 112.

Defining the response of the measurements and alarms during calibration

- * Select the analog input which is affected by the calibration.
- * Determine whether measurements (and alarms, if limit monitoring has been configured) are to be "frozen" or "not frozen" during calibration (HOLD function), see Chapter 10.3 "Response to calibration", Page 114.



Since calibration may also affect the measurements on other channels (e.g. the measurements of the channel used for temperature compensation of the pH value), a decision also has to be made for the affected channels as to how the measurements and alarms of these channels should respond during calibration.

Setting the calibration parameters

- * Select the analog input to which the pH measurement system is connected.
- * Select the "Calibration" menu.



- * Select the calibration procedure, calibration temperature and calibration mode.
- * Check the settings for the pH buffers 1 and 2 and adjust, if necessary
- * Select "Calibration"

Calibration steps

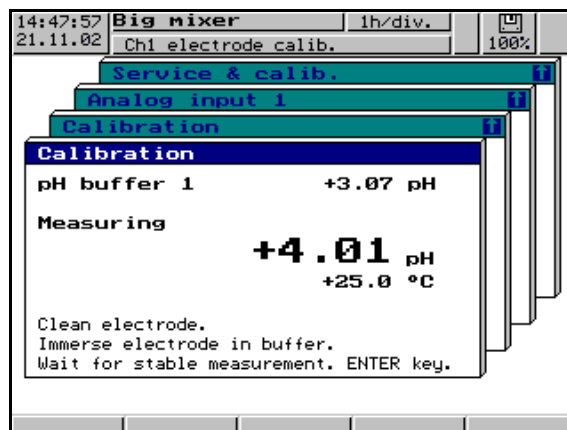

- * Measure the pH value of buffer 1.
Follow the steps according to the instructions (Help texts).

11 Calibration

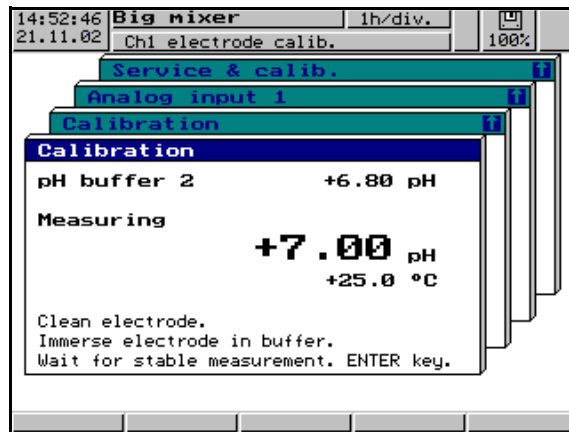

- * Measure the pH value of buffer 2.
Follow the steps according to the instructions (Help texts).

Calibration report

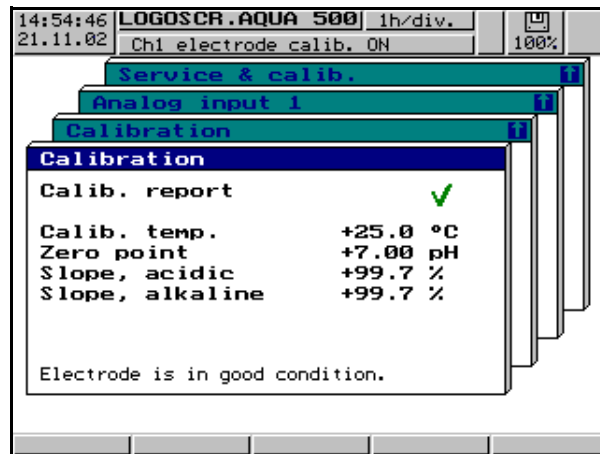

- * Evaluate calibration report using the calibration values determined.
The calibration measurements are now concluded.

Accepting the calibration values

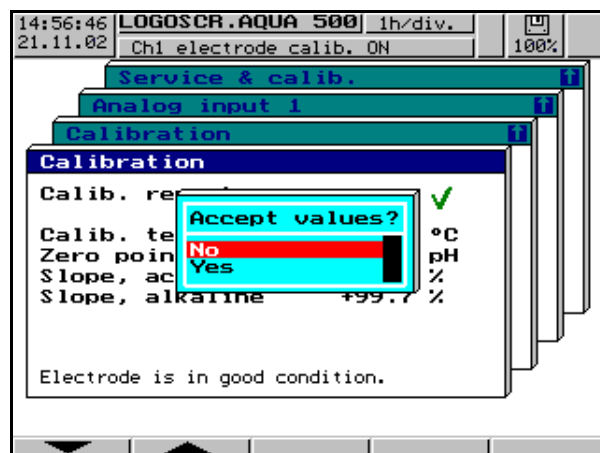

Calibration was successful: the new calibration values can be accepted by the instrument and will then appear in the calibration logbook.

11.2.3 Logbook for the pH electrode

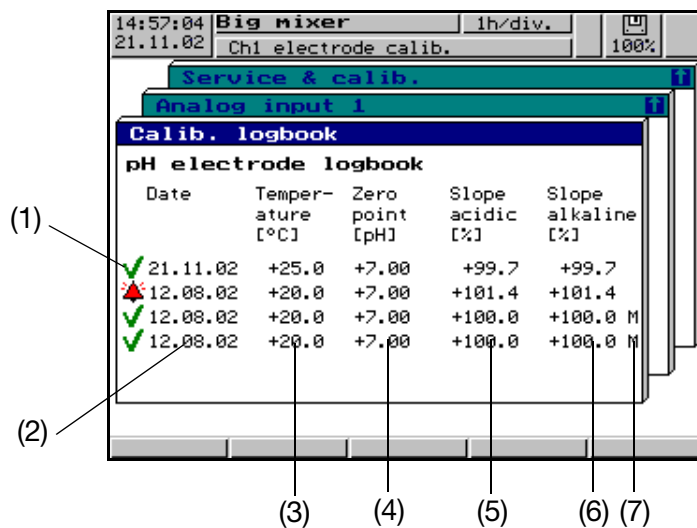

(1)	Evaluation of the electrode, see Chapter 10.4 “Logbook”, Page 117.	(4)	Zero point
(2)	Modification date of calibration values	(5)	Slope in the acidic range
(3)	Calibration temperature	(6)	Slope in the alkaline range
		(7)	Manual adjustments are marked by “M”

11 Calibration

11.3 Calibrating with conductivity transmitters

11.3.1 Basics

Calibration options

The cell constants of conductivity cells vary somewhat from one example to another, and also drift with use (because of deposits and wear). This results in a change of the output signal from the cell. It is therefore necessary for the user to be able to compensate deviations of the cell constant from the nominal value, either by manual input or by an automatic calibration of the relative cell constant.

The time intervals between calibrations depend on the conditions under which the cell is used.

The LOGOSCREEN AQUA 500 provides the option of determining the relative cell constant.

For pure conductivity measurements, the temperature coefficient of the solution to be measured must also be determined.

see Chapter 11.4 “Calibrating the temperature coefficient of a solution (for conductivity measurements)”, Page 140.

Relative cell constant



The relative cell constant K_{rel} can be used to compensate for the deviation of the real cell constant from the nominal cell constant.

The relative cell constant can be freshly determined by:

- using a reference solution with a known conductivity or
- an **uncompensated** comparison measurement.

Input of the calibration value

In addition to the calibration procedure described above, the LOGOSCREEN AQUA 500 offers the facility of manually entering the relative cell constant (as determined by a laboratory, for example),

Calibration value				Dimension
Cell constant	20 —	80 — 120	— 300	%

Cancel

By pressing the EXIT key (repeatedly, if necessary) you can change back to the measurement mode at any time.

11.3.2 Calibrating the cell constant of conductivity cells

You will need

- a conductivity test solution or a reference instrument on which the temperature compensation is **switched off**. The reference instrument serves to determine the conductivity of the calibration medium that is used during calibration.

Selecting the "Service & calibration" menu

- * Select the "Service & calib." menu and unlock, if necessary (code word 09200), see Chapter 10.1 "Entry of code number for the Service & calibration menu", Page 112.

Defining the response of the measurements and alarms during calibration

- * Select the analog input which is affected by the calibration.
- * Determine whether measurements (and alarms, if limit monitoring has been configured) are to be "frozen" or "not frozen" during calibration (HOLD function), see Chapter 10.3 "Response to calibration", Page 114.



Since calibration may also affect the measurements on other channels, a decision also has to be made for the affected channels as to how the measurements and alarms should respond during calibration.

Setting the calibration parameters

- * Select the analog input to which the conductivity cell is to be connected
- * Select the "Calibration" menu.

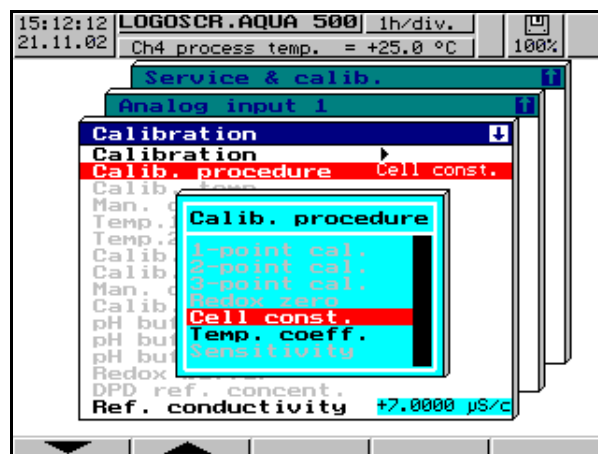

- * Select the "Cell constant" calibration procedure.

11 Calibration

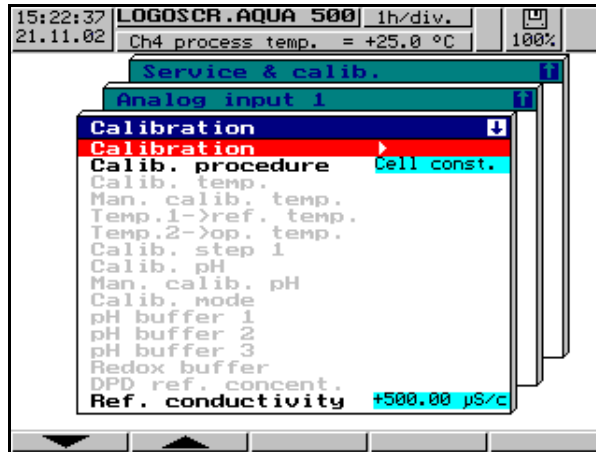

- * Enter the conductivity of the reference solution or the conductivity of the **uncompensated** comparison measurement.
- * Select "Calibration"

Calibration step

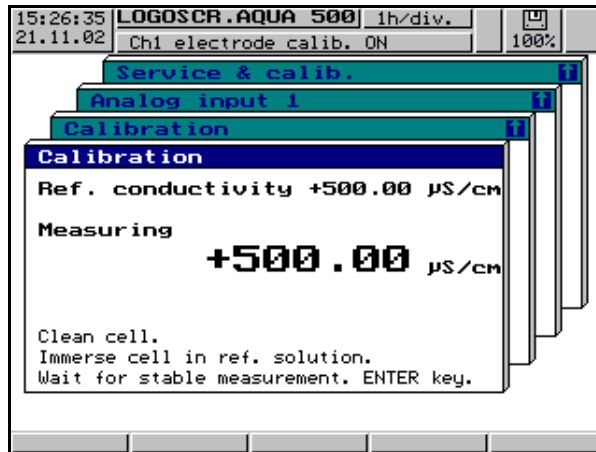

- * Measure the uncompensated conductivity value. Follow the steps according to the instructions (Help texts).

Calibration report

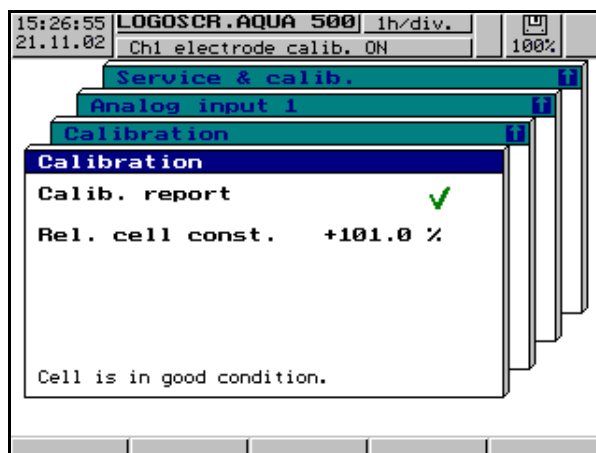

- * Evaluate calibration report using the cell constant determined.
- * Calibration measurement is now concluded.

Accepting the calibration values

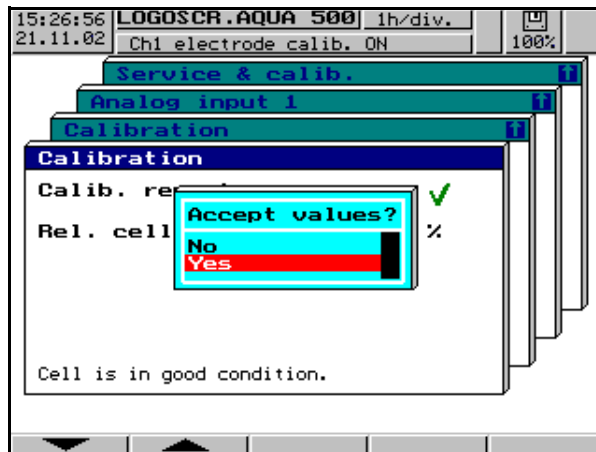

Calibration was successful: the new cell constant can be accepted by the instrument and will appear in the calibration logbook.

11.3.3 Logbook of conductivity cell

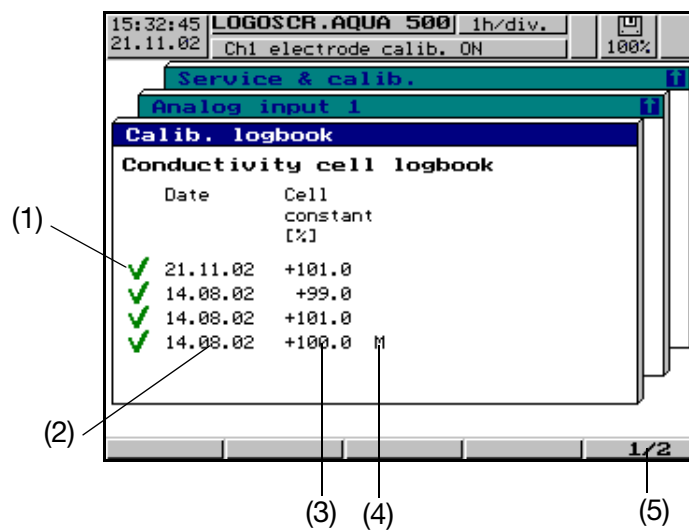

(1)	Evaluation of the measuring cell, see Chapter 10.4 “Logbook”, Page 117.	(4)	Manual adjustments are marked by “M”
(2)	Modification date of calibration values	(5)	Change to logbook “Temperature coefficient” only for conductivity measurement
(3)	Calibration temperature		

11 Calibration

11.4 Calibrating the temperature coefficient of a solution (for conductivity measurements)

11.4.1 Basics

Calibration option The conductivity of a solution depends strongly on temperature. To ensure correct measurement, it is therefore necessary to know both the temperature and the temperature coefficient of the measuring solution. The LOGOSCREEN AQUA 500 offers the option of determining the temperature coefficient.

Temperature coefficient The temperature coefficient is determined as follows during calibration: The instrument uses the non-temperature compensated measurements (TK = 0) at two different temperatures (a temperature close to the reference temperature and a second temperature, usually corresponding to the later measurement temperature) to determine the temperature coefficient of the solution being measured.

Input of the calibration value In addition to the calibration procedure described above, the LOGOSCREEN AQUA 500 offers the facility of manually entering the temperature coefficient (as determined by a laboratory, for example),

Calibration value		Dimension
Temperature coefficient	0 – 5.5	%/°C

11.4.2 Calibrating the temperature coefficient

You will need

- a sample of the medium to be measured
- a thermometer, if you want to use manual temperature compensation.
- a temperature probe, if you want to use automatic temperature compensation.
- a tempering setup to either heat up or cool down the solution being measured to two different temperatures.

Selecting the “Service & calibration” menu

- * Select the “Service & calib.” menu and unlock, if necessary (code word 09200)
see Chapter 10.1 “Entry of code number for the Service & calibration menu”, Page 112.

Defining the response of the measurements and alarms during calibration

- * Select the analog input which is affected by the calibration.
- * Determine whether measurements (and alarms, if limit monitoring has been configured) are to be “frozen” or “not frozen” during calibration (HOLD function),
see Chapter 10.3 “Response to calibration”, Page 114.

11 Calibration



Since calibration may also affect the measurements on other channels (e.g. the measurements of the channel used for temperature compensation), a decision also has to be made for the affected channels as to how the measurements and alarms of these channels should respond during calibration.

Setting the calibration parameters

- * Select the analog input to which the conductivity cell is connected.
- * Select the “Calibration” menu.

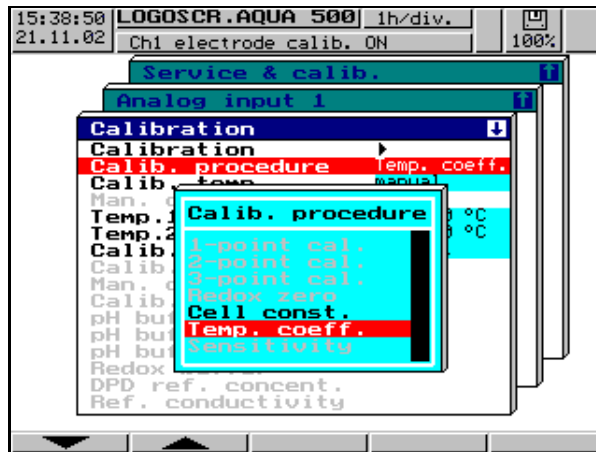

- * Select the “Temperature coefficient” calibration procedure.



- * Enter the temperatures that are reached during calibration.
- * Select the temperature at which calibration is started.
- * Select “Calibration”.

11 Calibration

Calibration steps

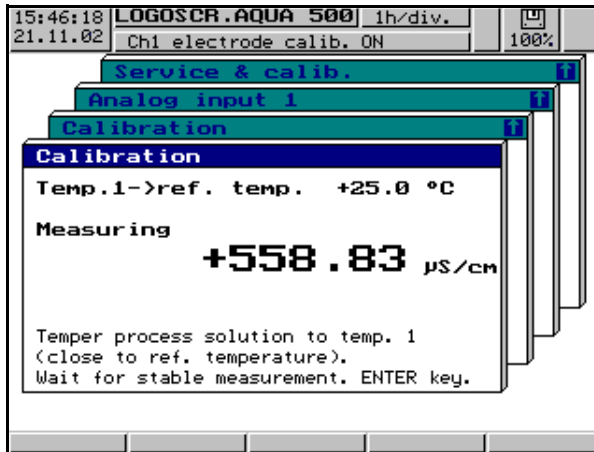

- * Measure the uncompensated conductivity close to the reference temperature. Follow the steps according to the instructions (Help texts).

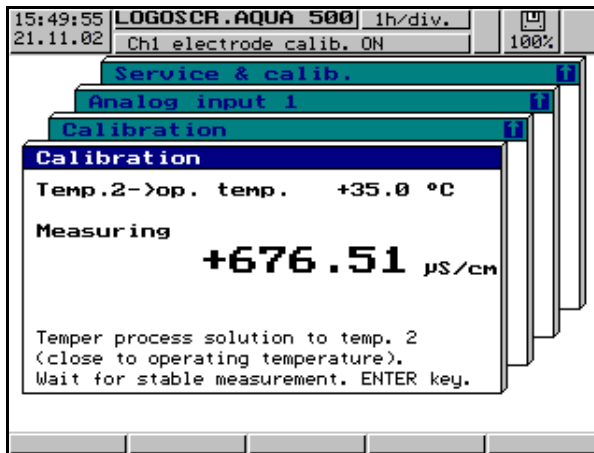

- * Measure the uncompensated conductivity close to the operating temperature. Follow the steps according to the instructions (Help texts).

Calibration report

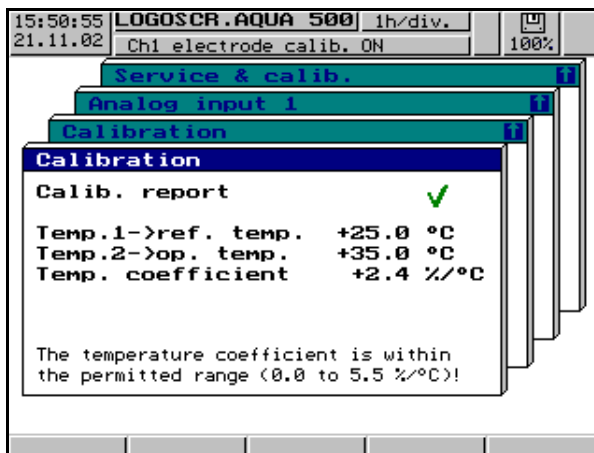

- * Evaluate the calibration report using the temperature coefficient that was determined. The calibration measurements are now concluded.

Accepting the calibration values

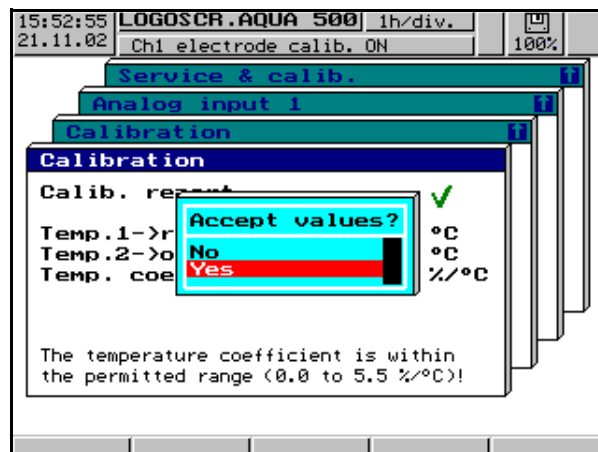

Calibration was successful:
the new temperature coefficient can be accepted by the instrument and will then appear in the calibration logbook.

11.4.3 Logbook for the temperature coefficient

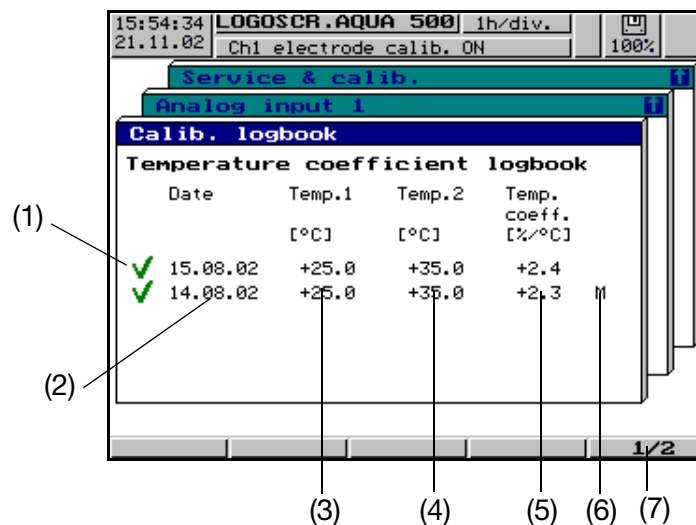

(1)	Evaluation of the measuring cell, see Chapter 10.4 "Logbook", Page 117.	(5)	Temperature coefficient
(2)	Modification date of calibration values	(6)	Manual adjustments are marked by "M"
(3)	Calibration temperature 1 (close to reference temp.)	(7)	Change to logbook "Cell constant" only for conductivity measurement
(4)	Calibration temperature 2 (close to operating temp.)		

11 Calibration

11.5 Calibrating measuring cells for free chlorine

11.5.1 Basics

Calibration options	<p>The chlorine cell is subject to a certain amount of ageing (e.g. dirt on the membrane), which is compensated by calibrating the sensitivity of the cell. JUMO measuring cells for free chlorine are membrane-covered sensors that do not require any zero-point correction. Only the sensitivity of the measuring cell at the working point has to be calibrated.</p>
Manual entry of the calibration values	<p>The sensitivity is allocated to a certain pH value and a certain temperature (calibration pH value and calibration temperature). Because of this dependence, each cell has to be calibrated individually. The sensitivity cannot be entered manually.</p> <p>Because of the interdependence of pH value, temperature and sensitivity, evaluation of the sensitivity has been deliberately dispensed with.</p>
Reference values	<p>With pH value/temperature compensation of free chlorine, reference is always made to the calibration pH value and the calibration temperature when determining the measurements after calibration. The aim here is to keep the indicated concentration constant when the process pH value and the process temperature change.</p>
DPD reference concentration	<p>A DPD test set is necessary for determining the DPD reference concentration. The DPD method is described in the EN ISO 7393-2 standard.</p> <p> Please observe the instructions for use of the DPD test set!</p> <p>Because of the volatility of the medium and the instability of free chlorine, it is advisable to perform the DPD determination and the subsequent calibration without delay.</p>

11.5.2 Calibrating a measuring cell for free chlorine

You will need

- a sample of the measurement medium taken in the immediate surrounding of the cell.
- a DPD test set to determine the reference concentration of free chlorine.

Selecting the "Service & calibration" menu

- * Select the "Service & calib." menu and unlock, if necessary (code word 09200), see Chapter 10.1 "Entry of code number for the Service & calibration menu", Page 112.

Defining the response of the measurements and alarms during calibration

- * Select the analog input which is affected by the calibration.
- * Determine whether measurements (and alarms, if limit monitoring has been configured) are to be "frozen" or "not frozen" during calibration (HOLD function), see Chapter 10.3 "Response to calibration", Page 114.



Since calibration may also affect the measurements on other channels (e.g. the measurements of the channels used for temperature and pH compensation), a decision also has to be made for the affected channels as to how the measurements and alarms of these channels should respond during calibration.

Setting the calibration parameters

- * Select the analog input to which the chlorine cell is connected.
- * Select the "Calibration" menu.

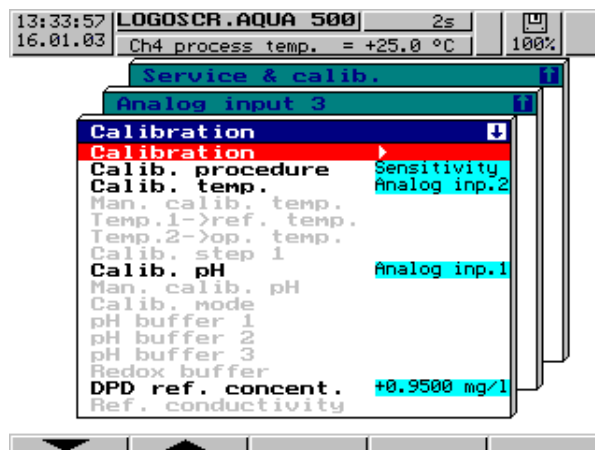

- * Enter the analog input that is used for temperature measurement
- * Enter the analog input that is used for pH measurement
- * Enter the DPD reference concentration
- * Select "Calibration".

11 Calibration

Calibration step

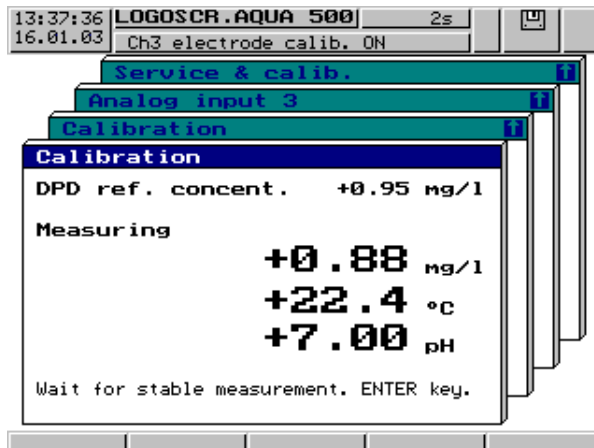

- * Measure the uncompensated chlorine concentration. Follow the steps according to the instructions (Help texts).

Calibration report

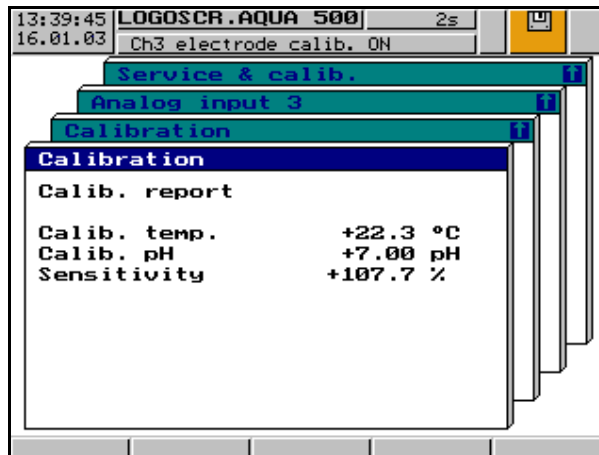

- * Evaluate the calibration report using the sensitivity that was determined. The calibration measurement is now concluded.

Accepting the calibration values

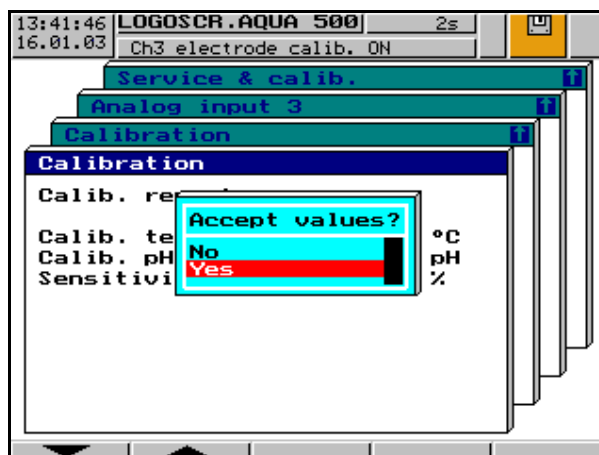

- * Calibration was successful: the calibration values can be accepted by the instrument.

11.5.3 Logbook for the chlorine measuring cell

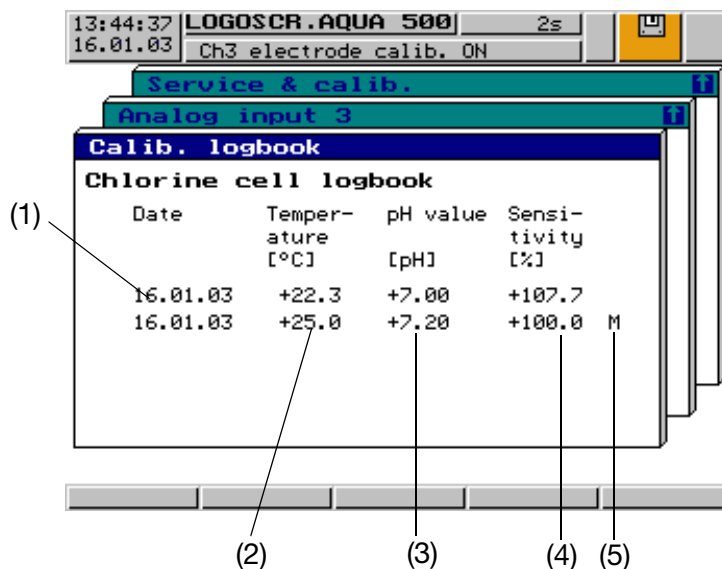

(1)	Modification date of calibration values	(4)	Sensitivity
(2)	Calibration temperature	(5)	Manual adjustments are marked by "M"
(3)	Calibration pH value		

11 Calibration

11.6 Calibrating measuring cells for chlorine dioxide or ozone

11.6.1 Basics

Calibration options	Measuring cells for chlorine and ozone are subject to a certain amount of ageing (e.g. dirt on the membrane), which is compensated by calibrating the sensitivity of the cell. JUMO measuring cells for free chlorine dioxide and ozone are membrane-covered sensors that do not require any zero-point correction. Only the sensitivity of the measuring cell has to be calibrated.
Manual entry of the calibration values	The sensitivity can be entered manually. The LOGOSCREEN AQUA 500 does not evaluate the sensitivity.
DPD reference concentration	A DPD test set is necessary for determining the DPD reference concentration. The DPD method is described in the DIN 38408 G5 (chlorine dioxide) and DIN 38408 G3 (ozone) standards.  Please observe the instructions for use of the DPD test set! Because of the volatility of the medium and its instability, it is advisable to perform the DPD determination and the subsequent calibration without delay.

11.6.2 Calibrating measuring cells for chlorine dioxide or ozone

You will need	<ul style="list-style-type: none">- a sample of the medium to be measured taken in the immediate surrounding of the cell.- a DPD test set to determine the reference concentration of chlorine dioxide or ozone.
Selecting the "Service & calibration" menu	<ul style="list-style-type: none">* Select the "Service & calib." menu and unlock, if necessary (code word 09200), see Chapter 10.1 "Entry of code number for the Service & calibration menu", Page 112.
Defining the response of the measurements and alarms during calibration	<ul style="list-style-type: none">* Select the analog input which is affected by the calibration.* Determine whether measurements (and alarms, if limit monitoring has been configured) are to be "frozen" or "not frozen" during calibration (HOLD function). see Chapter 10.3 "Response to calibration", Page 114.  Since calibration may also affect the measurements on other channels, a decision also has to be made for the affected channels as to how the measurements and alarms should respond during calibration.

Setting the calibration parameters

- * Select the analog input to which the chlorine dioxide or ozone cell is connected.
- * Select the "Calibration" menu.

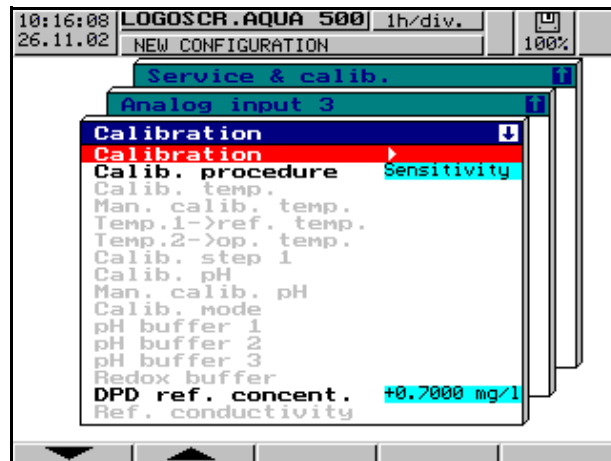

- * Enter the DPD reference concentration
- * Select "Calibration"

Calibration step

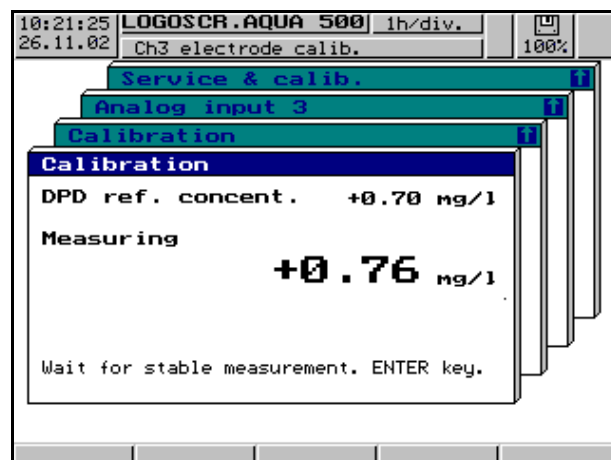

- * Measure the uncompensated concentration.
Follow the steps according to the instructions.

11 Calibration

Calibration report

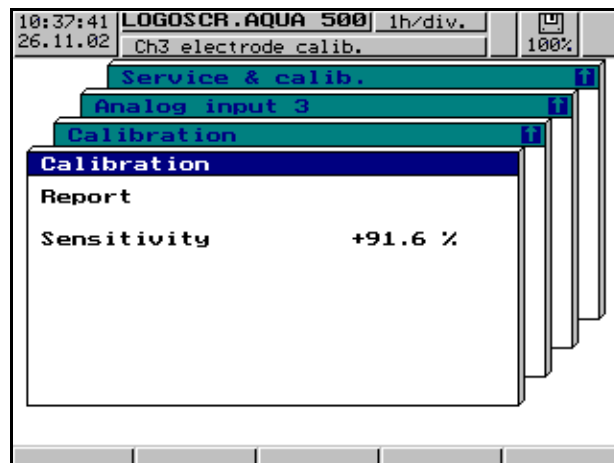

- * Evaluate the calibration report using the sensitivity that was determined. The calibration measurement is now concluded.

Accepting the calibration values

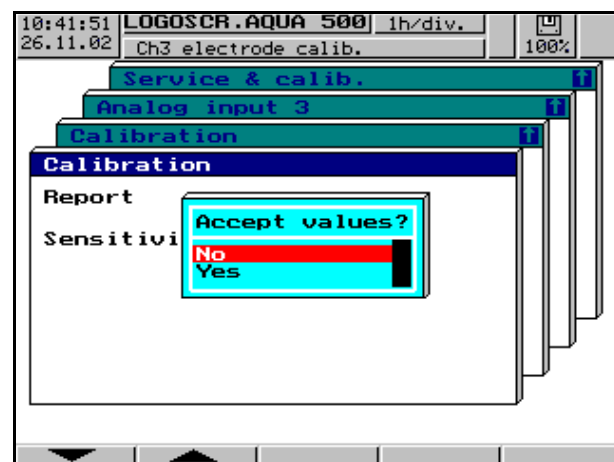

- * Calibration was successful: the sensitivity can be accepted by the instrument.

11.6.3 Logbook for the chlorine dioxide or ozone cell

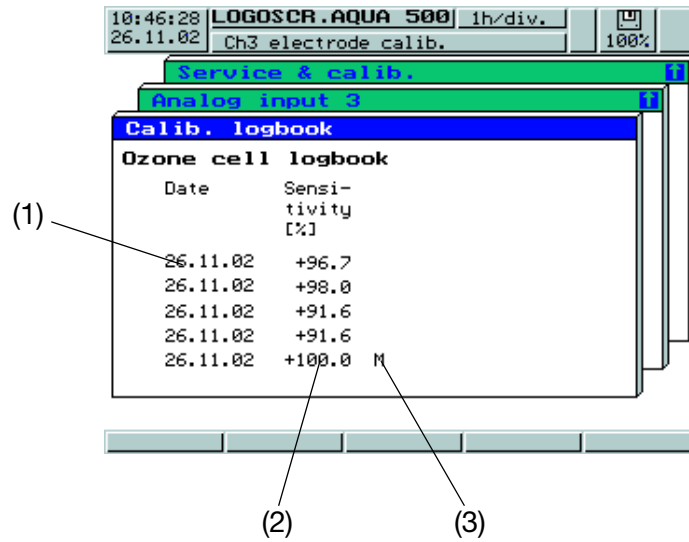

(1)	Modification date of calibration values	(3)	Manual adjustments are marked by "M"
(2)	Sensitivity		

12.1 Hardware and software requirements

A setup program for Windows® (from Version 95 or from NT4.0) is available as an accessory for the easy configuration of the LOGOSCREEN AQUA 500.

Hardware requirements

- PC-486DX-2-100
- 16 Mbyte RAM
- 15 Mbyte available on HD
- CD-ROM
- 3.5" disk drive

The program shows the current configuration as a list in the background. The corresponding input template is called up by a double click on the list, or via the menus.

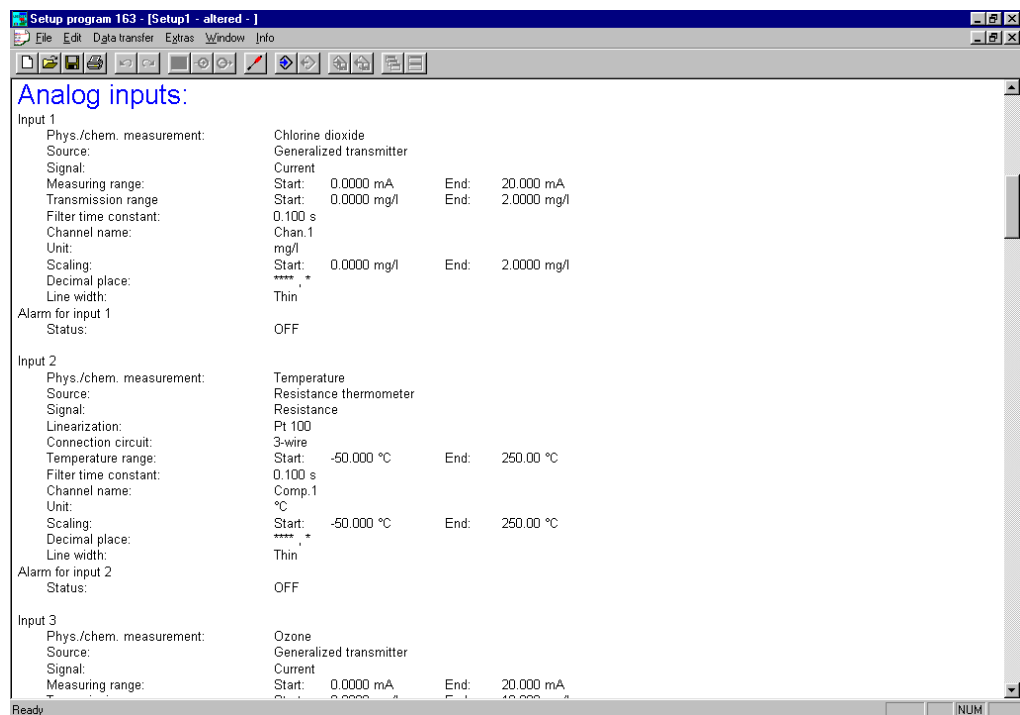

12.2 Installing the setup program

Running the installation program

- * Start Microsoft Windows®



If Microsoft Windows has already been started, all Windows programs have to be shut down before installing the setup program.

- * Insert CD
- * Select *Start* → *Run...*



- * Input e.g. "d:\start", depending on drive

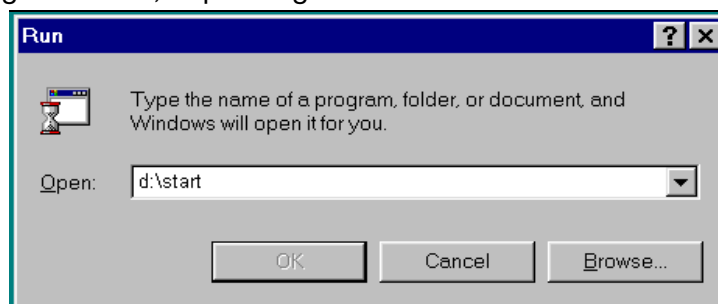

- * Click *OK*

The installation program will lead you through the rest of the installation with screen messages.



12 Setup program

12.3 Data exchange between LOGOSCREEN AQUA 500 and PC

The exchange of configuration data between the LOGOSCREEN AQUA 500 and a PC (setup program) is carried out via a 3.5" diskette or via a data transfer using the setup interface.

12.3.1 Data transfer via diskette

PC→
instrument

- * Make the settings in the setup program.
- * Write the settings to diskette by using the *Data transfer* → *Data export to diskette* menu, or by activating the  button.
- * Insert the diskette into the LOGOSCREEN AQUA 500 (remove the measurement data diskette first, if necessary).
- * Call up the *Disk Manager* menu on the LOGOSCREEN AQUA 500.
- * Select function *Diskette* → *Config. data* and activate .

After the configuration has been successfully read in, the LOGOSCREEN AQUA 500 will be automatically reset. If the measurement data diskette has been removed, a new diskette should be inserted.



Caution:

When the instrument is reconfigured:

- **all data will be deleted!**
- **the calibration parameters and calibration values will be reset to the default values!**
- **the logbooks are deleted and initialized with the default values (preset)!**

The data can be backed up on diskette **beforehand**, by using the disk manager.



Tip:

The calibration values and logbooks can be retained, if minor changes **that do not affect the analog inputs** and their electrodes or measuring cells are made in the configuration **from the instrument keys**.

Minor changes include, for example: setting the time, alteration of code numbers, changes to the text.



Do **not** use the menu function

„*File* → *Save as ...*“.

It cannot be used to create a valid diskette for the LOGOSCREEN AQUA 500.

Instrument →
PC

- * Insert the diskette into the LOGOSCREEN AQUA 500
 - * Call up the *Disk Manager* menu on the LOGOSCREEN AQUA 500.
 - * Select function *Config. data* → *Diskette* and activate .
-

12 Setup program

- * After a successful transfer, the diskette can be inserted into the PC.
- * Using the menu *Data transfer* → *Data import from diskette* menu, or by activating the  button, the data can be read into the setup program.

Import/export errors

If errors during transfer from and to diskette occur on the LOGOSCREEN AQUA 500 side, these will be indicated in the *Disk manager* menu and will remain until the error has been eliminated or is overwritten by a fresh error message.



A diskette containing configuration data must not have other files on it.



The diskette has to be formatted before use. It must not contain any data or faulty sectors. If this is disregarded, a fault free exchange of data cannot be ensured.

12.3.2 Data transfer via the setup interface



Caution:

When the instrument is reconfigured:

- **all data will be deleted!**
- **the calibration parameters and calibration values will be reset to the default values!**
- **the logbooks will be deleted and initialized with the default values (preset)!**

The data can be backed up on diskette **beforehand**, by using the disk manager.



Tip:

The calibration values and logbooks can be retained, if minor changes **that do not affect the analog inputs** and their electrodes or measuring cells are made in the configuration **from the instrument keys**.

Minor changes include, for example: setting the time, alteration of code numbers, changes to the text.

PC → instrument

- * Connect the setup cable to the serial interface of the PC (COM1, COM2, ...) and plug it into the recess on the left side of the LOGOSCREEN AQUA 500 housing.

12 Setup program

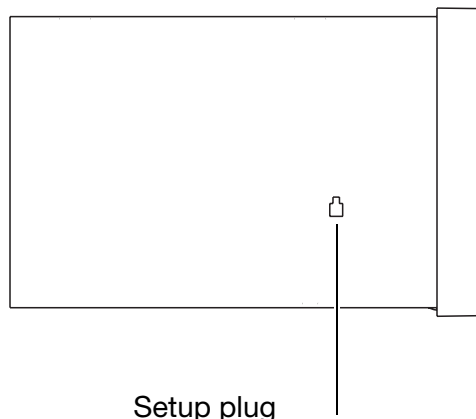

- * In the setup program, select the required serial interface on the PC by using the *Data transfer* → *Data transfer settings* menu
- * Transfer the settings to the LOGOSCREEN AQUA 500 using the *Data transfer* → *Data transfer to instrument* menu, or by activating the  button

Instrument → PC

- * Connect the setup cable to the serial interface of the PC (COM1, COM2, ...) and plug it into the recess on the left side of the LOGOSCREEN AQUA 500 housing.
 - * In the setup program, select the required serial interface on the PC by using the *Data transfer* → *Data transfer settings* menu
 - * Transfer the settings to the PC using the *Data transfer* → *Data transfer from instrument* menu, or by activating the  button
-

12.4 Customized linearization

The customized linearization tables are used to measure non-linear variables. Three tables with 50 value pairs each are available for entry in the setup program. One linearization can be used for several channels.

The values in the table must be monotonic. The definition range is subdivided into 50 sections of equal size before being transferred to the instrument. A linear approximation is made between the points that have been newly created in this way. The values of the first or last section are used for linearization outside the table.

The value range of the measurement is determined by the parameters “Scaling start” and “Scaling end”.

Example:
JUMO
Corrotrode

Example: JUMO Corrotrode for measuring the hydrogen peroxide concentration in sulfuric acid etching baths for PCB manufacture. The values in the table have to be determined for the specific process concerned, since these depend on the pH value/temperature.

Entry of the customized table in the setup program:

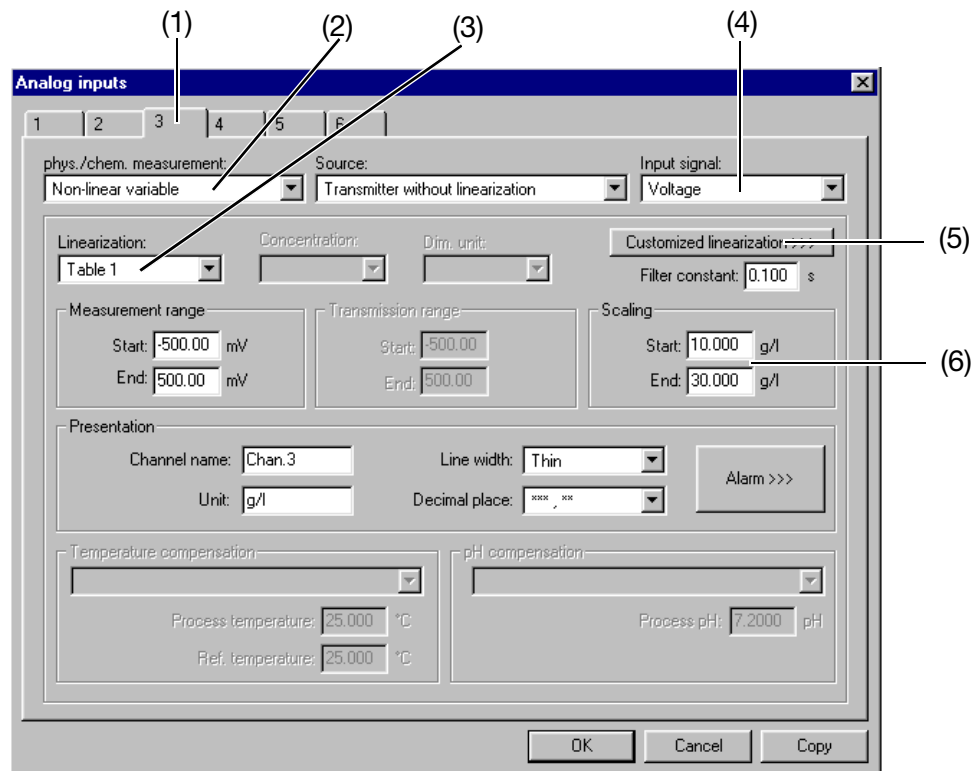

- * Configure analog input 3 (1) to non-linear variable (2):
Setup → *Edit* → *Analog inputs* → *Analog input 3*: among others, set
physical/chemical measurement (2) = non-linear variable
Input signal (4) = Voltage
Linearization (3) = Table 1
Scaling (6) = 10 — 30 g/l
- * Press button *Customized linearization* (5).

12.5 Math and logic module

The math and logic module is available as an option.

The math and logic module is composed of channels that are not available as hardware but are calculated by the instrument software.



If a math channel is used (e.g. math channel 3), the corresponding analog channel (e.g. AE3) is no longer available.

This does **not** apply to the logic channels.

Math

You can activate the math channels in the setup program under “Analog inputs” (or via *Menu* → *Edit analog inputs*).

Analog inputs:

In the example below, channel 3 is used as a math channel:

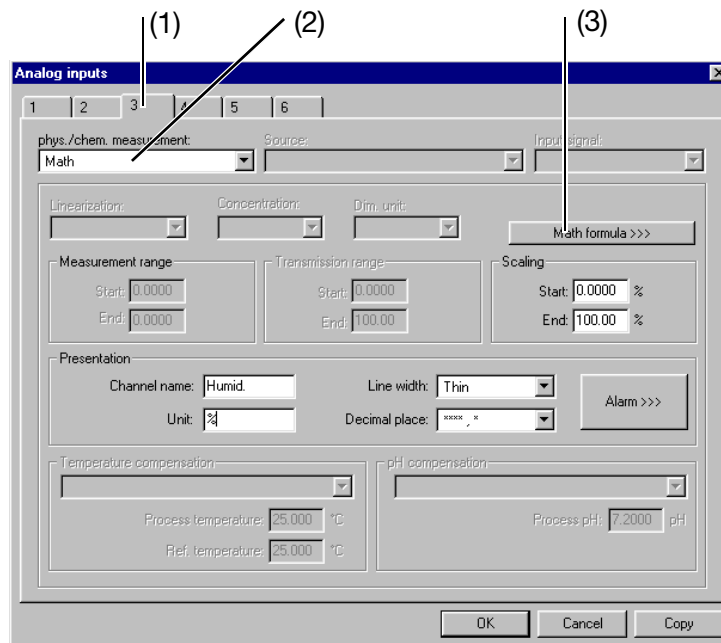

- * Select channel (1)
- * Select Math (2)
- * Start Math formula editor (3).

12 Setup program

4.) Function selection

The function is selected here. All other fields can subsequently be edited according to the function.

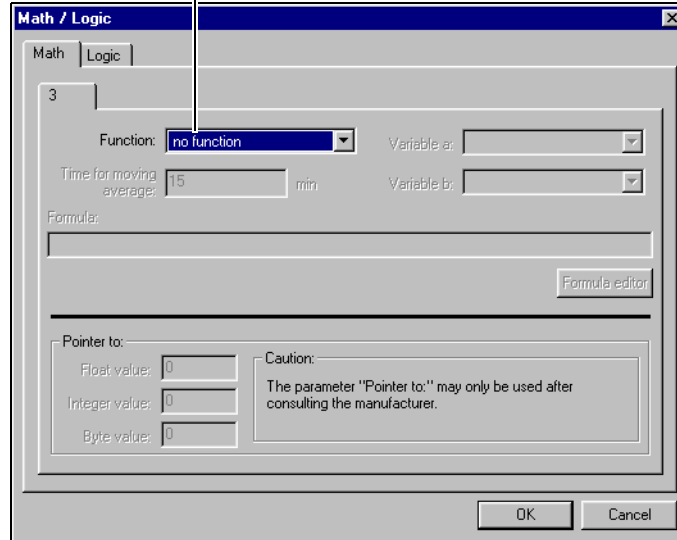

The input fields “Variable a”, “Variable b” or “Time for moving average” have to be edited when one of the standard functions (difference, ratio, humidity, moving average) has been set.

If you have set the “Formula” function, then the input field “Formula” must be edited. Entry can either be direct or via a (**Formula editor**) dialog.

Example: humidity

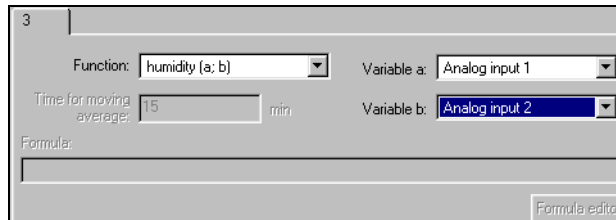

With humidity measurement, the channel for dry bulb temperature has to be specified as variable a, the channel for the wet bulb temperature as variable b.

Example: formula

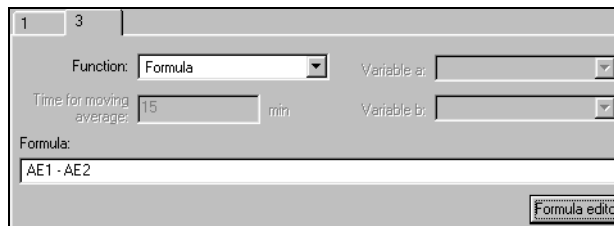

The formula can be entered directly from the PC keys or by calling up the **Formula editor** function.

Formula editor

When you have called up the function, this dialog box will appear:

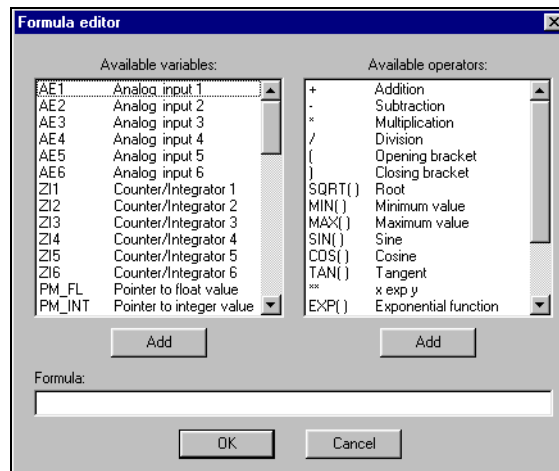

In the left window you can select the desired signal, in the right window the required operator, and enter them into the formula by activating (**Add**). Instead of **Add**, the selection can also be entered by a double-click with the left mouse button.

For functions ending with (), you will have to add the closing bracket yourself.

Example: 1. add SQRT() --> **SQRT(**
 2. add AE1 --> **SQRT(AE1**
 3. add) --> **SQRT(AE1)**

12 Setup program

Overview of operators

Operator	Explanation	Example
+	addition	AE1 + AE2
-	subtraction	AE1 - AE2
*	multiplication	AE1 * AE2
/	division	AE1 / AE2
(opening bracket	(
)	closing bracket)
SQRT()	square root	SQRT (AE1)
MIN()	minimum value	MIN (AE1, AE2)
MAX()	maximum value	MAX (AE1, AE2, AE3)
SIN()	sine	SIN (AE1)
COS()	cosine	COS (AE1)
TAN()	tangent	TAN (AE1)
**	x to the power y	AE1 ** AE2
EXP()	exponential function	EXP (AE1)
ABS()	absolute value	ABS (AE1)
INT()	integer portion	INT (AE1)
FRC()	decimal portion	FRC (AE1)
LOG()	logarithm	LOG (AE1)
LN()	natural logarithm	LN (AE1)

12 Setup program

12.6 Character set (characters can be represented in setup program)

032		080	P	0162	¢	0210	Ò
033	!	081	Q	0163	£	0211	Ó
034	"	082	R	0164	¤	0212	Ô
035	#	083	S	0165	¥	0213	Õ
036	\$	084	T	0166	¦	0214	Ö
037	%	085	U	0167	§	0215	×
038	&	086	V	0168	¨	0216	Ø
039	'	087	W	0169	©	0217	Ù
040	(088	X	0170	ª	0218	Ú
041)	089	Y	0171	«	0219	Û
042	*	090	Z	0172	¬	0220	Ü
043	+	091	[0173	-	0221	Ý
044	,	092	\	0174	®	0222	Þ
045	-	093]	0175	¯	0223	ß
046	.	094	^	0176	°	0224	à
047	/	095	_	0177	±	0225	á
048	0	096	`	0178	²	0226	â
049	1	097	a	0179	³	0227	ã
050	2	098	b	0180	´	0228	ä
051	3	099	c	0181	µ	0229	å
052	4	0100	d	0182	¶	0230	æ
053	5	0101	e	0183	·	0231	ç
054	6	0102	f	0184	¸	0232	è
055	7	0103	g	0185	¹	0233	é
056	8	0104	h	0186	º	0234	ê
057	9	0105	i	0187	»	0235	ë
058	:	0106	j	0188	¼	0236	ì
059	;	0107	k	0189	½	0237	í
060	<	0108	l	0190	¾	0238	î
061	=	0109	m	0191	¿	0239	ï
062	>	0110	n	0192	À	0240	ð
063	?	0111	o	0193	Á	0241	ñ
064	@	0112	p	0194	Â	0242	ò
065	A	0113	q	0195	Ã	0243	ó
066	B	0114	r	0196	Ä	0244	ô
067	C	0115	s	0197	Å	0245	õ
068	D	0116	t	0198	Æ	0246	ö
069	E	0117	u	0199	Ç	0247	÷
070	F	0118	v	0200	È	0248	ø
071	G	0119	w	0201	É	0249	ù
072	H	0120	x	0202	Ê	0250	ú
073	I	0121	y	0203	Ë	0251	û
074	J	0122	z	0204	Ì	0252	ü
075	K	0123	{	0205	Í	0253	ý
076	L	0124		0206	Î	0254	þ
077	M	0125	}	0207	Ï	0255	ÿ
078	N	0126	~	0208	Ð		
079	O	0161	j	0209	Ñ		

12 Setup program

12.7 Character set (characters cannot be represented in setup program)

0127		0136	␣	0145	ı	0154	z
0128	⌘	0137	␣	0146	ı	0155	z
0129	-	0138	␣	0147	Ω	0156	-
0130	↑	0139	␣	0148	Ω	0157	*
0131	↓	0140	α	0149	∞	0158	⌋
0132	←	0141	Γ	0150	Ξ	0159	∨
0133	→	0142	Σ	0151	Δ	0160	
0134	␣	0143	σ	0152	π		
0135	␣	0144	θ	0153	η		

Input of special characters

(Special) characters which cannot be input directly from the keypad of the PC can be input by using the ALT key and the number combination specified in the table.

Example

The special character © has to be input:

- * Position the cursor with the mouse, or by using the cursor keys, on the insertion point of the character
- * Press the ALT key **and hold it down**
- * Enter the number combination 0169 in the number block (on the right-hand side of the keypad) (the leading zero **must** be entered as well)
- * Release the ALT key

The character © is inserted at the cursor position.

13 PC evaluation program

13.1 Program description



The PC evaluation program (PCA) is described in more detail in the Operating Instructions B 95.5099.

The PC evaluation program (PCA) can be run from Windows 95 or higher and is available for managing, archiving, visualizing and evaluating the data saved to diskette of instruments in the LOGOSCREEN series, among them the LOGOSCREEN AQUA 500.

Hardware and software requirements

The following hardware and software requirements have to be met for installing and operating the evaluation program:

- IBM-PC or compatible PC from 486 processor
- 16 MB main memory
- 3.5" disk drive
- CD-ROM drive (for installation and to create a set of diskettes)
- mouse
- VGA graphics
- Windows 95/98/NT4.0

Recommended minimum configuration

- Pentium 133
- 32MB main memory
- 100MB available on hard disk

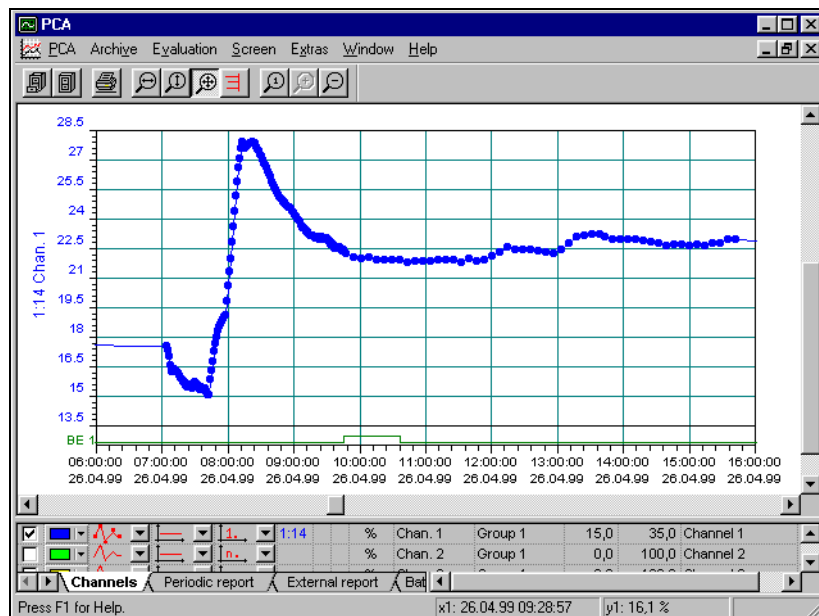

13 PC evaluation program

Features

Some features in brief

- The data from differently configured instruments are recognized by the PCA evaluation program and stored in an archive database. The entire management is performed automatically. The user only has to manually allocate an identifier (supplementary description).
- The user can at any time gain access to certain data sets, which can be distinguished by the identifier. In addition, it is possible to restrict the time periods to be evaluated.
- Any analog or digital channels of the LOGOSCREEN can subsequently be combined in PCA into PCA groups
- Operation via mouse or keys
- Using the export filter it is possible to export (CSV format) the stored data (e.g. calibration logbooks, etc.) for processing in different programs (Excel, ...)
- Using the additional program "Communication server", the data can be read out of the LOGOSCREEN via the serial interface (RS232/RS485). They can be read out manually or automatically (e.g. daily at 23.00 hrs). It is recommended to use a baud rate of 38400 bps for the data transfer. On the LOGOSCREEN, the baud rate is set via the parameter *Configuration* → *Interface* → *Baud rate*.
- The PCA evaluation program supports the network capability, which means that several users can obtain data from the same database, independently of one another
- Data diskettes can be read out and stored in the database via the rapid start function of the evaluation program. After archiving, the evaluation software will be automatically terminated.

TECHNICAL REPORT ON DATA-MANIPULATION SECURITY

Paperless recorder series
LOGOSCREEN

Manufacturer
M.K. Juchheim
Moltkestraße 13-31
D-36039 Fulda

Report-No.: MF58870
Revision 1.0 of 11th February 2000

Test and Certification Body:
TÜV Product Service GmbH
Automation, Software and Electronics - IQSE
Ridlerstraße 65
D-80339 Munich

This technical report may only be reproduced in its entirety. Its use for advertising purposes requires prior written permission. It contains the results of a single examination of the product submitted for testing, and does not represent a generally valid verdict on features in current production.

Technical report on the data-manipulation security of the LOGOSCREEN series of paperless recorders

Contents	Page
1 Subject of Testing.....	3
2 Scope of Testing.....	3
2.1 Test specimen.....	3
2.2 Scope of test specimen.....	3
2.3 Tests.....	3
3 Testing principles.....	4
3.1 Quality management during the test.....	4
4 Test material.....	4
5 Test documentation.....	4
6 Performance and result of test.....	5
6.1 Data security.....	5
6.1.1 Definition of the security objectives.....	5
6.1.2 Threat analysis.....	5
6.1.3 Penetration tests.....	6
6.2 Testing of fault avoidance measures.....	6
6.3 Security instructions in the product documentation.....	6
7 Summary.....	7

1 Subject of Testing

This technical report describes the performance and the individual results of the test of the LOGOSCREEN series of paperless recorders with regard to data-manipulation security.

The test was instigated by the company M. K. Juchheim in November 1999.

2 Scope of Testing

2.1 Test specimen

The LOGOSCREEN series of paperless recorders includes the types LOGOSCREEN and LOGOSCREEN 500. These are electronic X-t recorders for the acquisition, visualization, storage and evaluation of analog and digital measurement data. The instruments are controlled by microprocessors, and can be configured through various interfaces. The instruments are intended to replace the usual pen and dot-matrix chart recorders. The design is suitable for mounting in equipment cabinets. Data are archived on diskettes, instead of on paper chart rolls. As an alternative, the data can be read out via a serial interface and archived on PCs. In this case, available media include not only diskettes, but also CDROM, magneto-optical disks etc. The measurement signals are applied to plug-in screw terminals on the back panel of the instrument, and are digitalized and stored at adjustable intervals. The further processing can be determined by configuration. For instance, a selection may be made between continuous storage, storage in a time-slot (window) and event-controlled storage.

2.2 Scope of test specimen

The test specimen comprised the following listed components:

- LOGOSCREEN instrument
- user documentation

2.3 Tests

The product was investigated in the following test stages:

- Data security
 - Definition of the security objectives
 - Threat analysis
 - Penetration tests
- Test of fault avoidance measures
- Security instructions in the product documentation

3 Testing principles

In view of the application of the LOGOSCREEN series of paperless recorders and the main theme of the test – data-manipulation security – the tests performed were derived from the following guidelines:

GSH98	IT Basic Security Manual 1998 („Grundschutzhandbuch“)
-------	---

3.1 Quality management during the test

QSH (Version 2)	Quality Assurance Manual of TÜV Product Service GmbH
QSH IQSE (Version 1.4)	Quality Assurance Manual of IQSE
EN 45001 (05.90)	General Criteria for the Operation of Test Laboratories

4 Test material

The following documents and test samples were used as material for the test:

[U1]	LOGOSCREEN instrument type: 955010 (6-channel) SN# 0040528301099450008
[U2]	PC evaluation program (PCA Version 108.02.04; Prg.Ver. 3.02) on CD-ROM
[U3]	Operating Manual B95.5010.0.1
[U4]	Operating Manual B95.5010.2.2
[U5]	high-level data flowcharts and functional overviews
[U6]	various test plans and test records for LOGOSCREEN and the evaluation software

5 Test documentation

The following documents containing the individual test results have been prepared by the test agency:

[P1]	Report of the meeting with the company M. K. Juchheim on 8 th December 1999
[P2]	Threat analysis / System-FMEA for the paperless recorder LOGOSCREEN, Version 0.2 on 3.1.2000
[P3]	Penetration tests on the paperless recorder LOGOSCREEN, Version 1.0 on 25 th January 2000

6 Performance and result of test

6.1 Data security

6.1.1 Definition of the security objectives

Security objectives for the LOGOSCREEN series of paperless recorders were laid down jointly with M. K. Juchheim, (see also document [P1]). These have been listed in the following table.

6.1.2 Threat analysis

A threat analysis was carried out for the defined security objectives, on the basis of the system structure as presented. The safety measures that were identified are divided into technical and organizational measures, as well as measures for the avoidance of errors during development.

Security objective	Threat	Measures
1 Correct and reproducible recording of the measurement signals that are applied, in accordance with the user-defined configuration.	Data may be incorrectly recorded (e.g. incorrect scaling, wrong sampling rate etc.)	A defined, practised and proven systematic software development procedure, with verification and validation steps laid down to achieve a correct implementation.
2 Recognition of gaps in the recording and/or recognition that data have been deleted.	Removal of the storage media, switch-off of the recorder, deletion of data	All recordings have a corresponding current date and time mark attached. The evaluation software permits the display of all stored data. The operator can use this software to search for gaps in the recordings. Assistance is provided by recorded events, such as power on/off.
3 Recognition that data have been altered without authorization	Data recordings may be wholly or partly manipulated at a later date.	Data are stored in an unpublished binary format. Intentional alteration is therefore not possible. A blockwise signature secures all stored data.
4 Protection of the instrument configuration from unobserved changes.	Unauthorized changes to protocol parameters or the date.	A 5-character password protects access to the configuration menu. The instruments are delivered with a preset active access protection. All changes to the configuration are recorded.

Test result:

The threat analysis showed that measures are identified to protect against each of the threats to the defined security objectives and that the measures are sufficient to secure the correctness of the implementation and provide effective security against manipulation of data. The results are recorded in the document [P2].

6.1.3 Penetration tests

The technical measures were investigated for vulnerabilities by penetration tests on an series instrument in working condition, see [U1]. The extensive master test plans and test records provided by M. K. Juchheim were inspected.

Test result:

The performed penetration tests revealed no vulnerabilities in the data format and the corresponding error-detection routines. These results are recorded in document [P3]. The tests that were carried out and documented by M. K. Juchheim also failed to show any indication of a deficiency.

6.2 Testing of fault avoidance measures

The European methodology for certificates of conformity (93/465/EEC „Decision of the Council on 22nd July 1993 on the modules to be applied in the technical harmonization guidelines for the various phases of the conformity evaluation procedure, and the rules for application and use of the CE-conformity mark“) attach importance to the manufacturer's quality assurance in production and maintenance. The company M. K. Juchheim fulfils these requirements through a certified and monitored quality management system according to (DIN) ISO 9001. Furthermore, the company operates an accredited calibration laboratory.

The documentation [P3] that has been presented testifies that the quality management system is applied to the LOGOSCREEN and includes the measures required for the first security objective.

6.3 Security instructions in the product documentation

The inspection of the technical documentation was made on the Operating Manual (see document [U3]) and the Interface Description (see document [U4]). Only the data security aspect was considered. The documentation does not include explicit notes on data security. The use of the password protection for the configuration is described. Details on the significance of diskette characteristics and diskette storage for data integrity are not provided.



7 Summary

The concept and properties of the LOGOSCREEN series of paperless recorders make them into a possible electronic replacement for pen or dot-matrix chart recorders, with additional mechanisms to ensure the integrity of the data and security against manipulation. The effectiveness of the implemented mechanisms secures the envisaged application reliably, provided that the storage conditions and archive duration for diskettes or the selected backup media are respected. The user must take care that the evaluation software to read the measurement data and the operating system that is required are available for the required duration of the archiving of his measurement data.

on behalf of

TÜV PRODUCT SERVICE GMBH
Automation, Software and Electronics - IQSE
Project manager

A handwritten signature in black ink, appearing to read 'Reiner Heilmann', written over the printed name.

Reiner Heilmann

TÜV PRODUCT SERVICE GMBH
Automation, Software and Electronics- IQSE
Rüdigerstraße 65
D-80339 Munich
Phone: (089)5791-1797; Fax: -1396

Report No.: MF58970, Revision 1.0
Order-Nr.: 10030052
Engineer: Reiner Heilmann
11th February 2000
Page 7 of 7

A

Action (outputs) 86
Alarm 78
Alarm (counter/integrator) 83
Alarm delay 79
Alarm text (counter/integrator) 83
Analog inputs 75–79

B

Battery empty 64–65
Baud rate 88
Block diagram 9

C

Calibration status 88
Channel (counter/integrator) 81
Channel indication 72
Channel line 72
Channel name (counter/integrator) 82
Channel representation 72
Character entry 66
Character selection 66
Chlorine (free)
 Calibration 144
 Configuration example 100
 Connection example 100
 DPD reference concentration 148
 Logbook 147
Chlorine dioxide
 Calibration 148
 Configuration example 106
 Connection example 106
 DPD reference concentration 148
 Logbook 151
Code number 67, 74
Concentration measurement
 Calibrating the cell constant 137
 Calibration 136
 Configuration example 108
 Connection example 108
 Logbook of cell constant 139
Conductivity
 Calibrating the cell constant 137
 Calibrating the temperature coefficient 140
 Calibration 136
 Configuration example 96
 Connection example 96
 Logbook of cell constant 139
 Logbook of temperature coefficient 143
Configuration
 Analog inputs 75
 Control functions 87

Counter/integrator 81
Event traces 80
Fine calibration 88
Interface 88
Measurement storage 85
Outputs 86
Texts 87

Configuration data, write to/read from disk. 61
Contrast 71
Control function 87
Control signal 72, 85
Control signal (outputs) 86
Counter 81
Counter frequency (counter/integrator) 36
Counter text (counter/integrator) 82
Counter/int. reset 74

D

Daily end time (counter/integrator) 84
Daily start time (counter/integrator) 84
Data format 88
Data lost 64–65
Data manipulation security 167
Date 73
Decimal place 78
Decimal place (counter/integrator) 82
Differential 79
Disk code number 74
Disk manager 59
Diskette reserve 74
Displays and controls 28

E

End time (timed operation) 85
End value,
 set 88
Error 65
ESD 6
Evaluation of measurement data 49
Evaluation program 59
Event definition 59
Event list 57
Event operation
 Storage rate 85
 Stored value 85
Event traces 34
Ext. control signal (counter/integrator) 83
External text 35, 87

F

Function (counter/integrator) 81

15 Index

H

Header 72
History 49
Humidity measurement 160

I

Identification of instrument 11
Import/export errors 155
Input signal 80
Input signal (counter/integrator) 81
Instrument address 88
Instrument info 64
Instrument name 73
Instrument software 64
Integrator 81
Interface type 88

K

Key inhibit 87

L

Language 74
Limit value (counter/integrator) 83
Line width 78

M

Memory alarm 61, 74
Memory upload 74
Mounting in position 20

N

Normal operation
 Control signal 85
 Storage rate 85
 Store status 85
 Stored value 85

O

Outputs 86–87
 Action 86
 Control signal 86
Ozone
 Calibration 148
 Configuration example 106
 Connection example 106
 DPD reference concentration 148
 Logbook 151

P

Paper perforations 72
Parameterization 71

Password 67, 74
Period (counter/integrator) 83
pH
 1-point calibration 130
 2-point calibration 131–132
 3-point calibration 131
 Buffer 132
 Calibration 130
 Configuration example 90
 Connection example 90
 Logbook 135
 Semi-automatic calibration 119
Protocol 88

R

Redox
 Configuration example 94
 Connection example 94
Reset (counter/integrator) 72
Reset generation (counter/integrator) 84
RS232/RS485 code number 74

S

Screen saving 71
Scroll operation 49
Setup program, installation of 153
Signal type 72
Signal types 34
Speed indication 71
Standard text 58
Start time (timed operation) 85
Start value
 actual 88
 set 88
Status line 30
Status message 62
Storage rate 85
Store status 85
Stored value 85
Summer time 73
Supplementary text 58
Switch-off event 71
Synchronizing time (counter/integrator) 83

T

Temperature unit 74
Text entry 66
Text high alarm 79
Text low alarm 79
Texts 59, 87
Threshold value (counter/integrator) 82
Time 73

Time base (counter/integrator) 82

Time synchronization 73

Timed operation

End time 85

Start time 85

Trace designation 80

Transfer

PC-recorder 155

Recorder-PC 154, 156

Type (counter/integrator) 81

U

Unit 78

Unit (counter/integrator) 82

V

Version number 64

W

Waiting time 71

Weekday (counter/integrator) 83

Weighting (counter/integrator) 81

Window technology 56

