

TZIDC, TZIDC-200

Digital positioner



Technical description for manual configuration of the contactless 360° sensor.

—
TZIDC
TZIDC-200

Introduction

Devices from HW rev.: 5.01 can be equipped with the order option “Contactless position feedback”. The position feedback then takes place via a 360° sensor without mechanical end stops.

This allows a wider operating range of up to 350°. The operating range can then be at any point in the sensor range.

If the device's installation situation is different from the standard described in the operating instructions, such as gear rack actuators, further parameter settings will be required.

The parameter settings are described in this Technical description.

Additional Information

Additional documentation on TZIDC, TZIDC-200 is available for download free of charge at www.abb.com/positioners. Alternatively simply scan this code:



Table of contents

1	Introduction	3
	Automatic adjustment.....	3
	Area of application.....	3
2	Manual configuration of end positions	4
	Example.....	4
	Manual configuration of the parameters.....	5
	Procedure	5

1 Introduction

Automatic adjustment

The standard automatic adjustment for rotary and linear actuators is performed as described in the operating instructions under **Standard automatic adjustment**.

For different installation situations, such as gear rack actuators or valves that do not feature mechanical restrictions or that could be damaged when activating the end positions, the user has to manually configure the relevant parameters during commissioning.

The parameter settings are described in this Technical description.

Also observe the operating instructions for the positioner.

Area of application

The configurations described in this Technical description apply only to digital positioner TZIDC / TZIDC-200 from HW-REV.: 05.01.xx and order option "**S1 – Contactless sensor**".

2 Manual configuration of end positions

Example

The following figure is a sample depiction of the operating range of a TZIDC, TZIDC-200 after the parameters for the contactless sensor in the positioner have been configured manually.

The following initial situation is assumed:

- The actuator uses spring force or ventilation to move clockwise from OUT2 to an opening degree of 0%.

In order for the operating range of the positioner (P6.0–MIN_VR, P6.1–MAX_VR) to be fully defined, the parameters P6.7–ZERO_POS and P6.3–SPRNG_Y2 must additionally be positioned toward the relevant rotational direction during commissioning.

In this case, it applies to the following configurations:

- P6.7 (ZERO_POS) = CLOCKWISE (Figure 1, Pos. (E))
- P6.3 (SPRNG_Y2) = CLOCKWISE (Figure 1, Pos. (D))

Note

Depending on the relevant installation situation, the parameters must always be determined and configured individually on site.

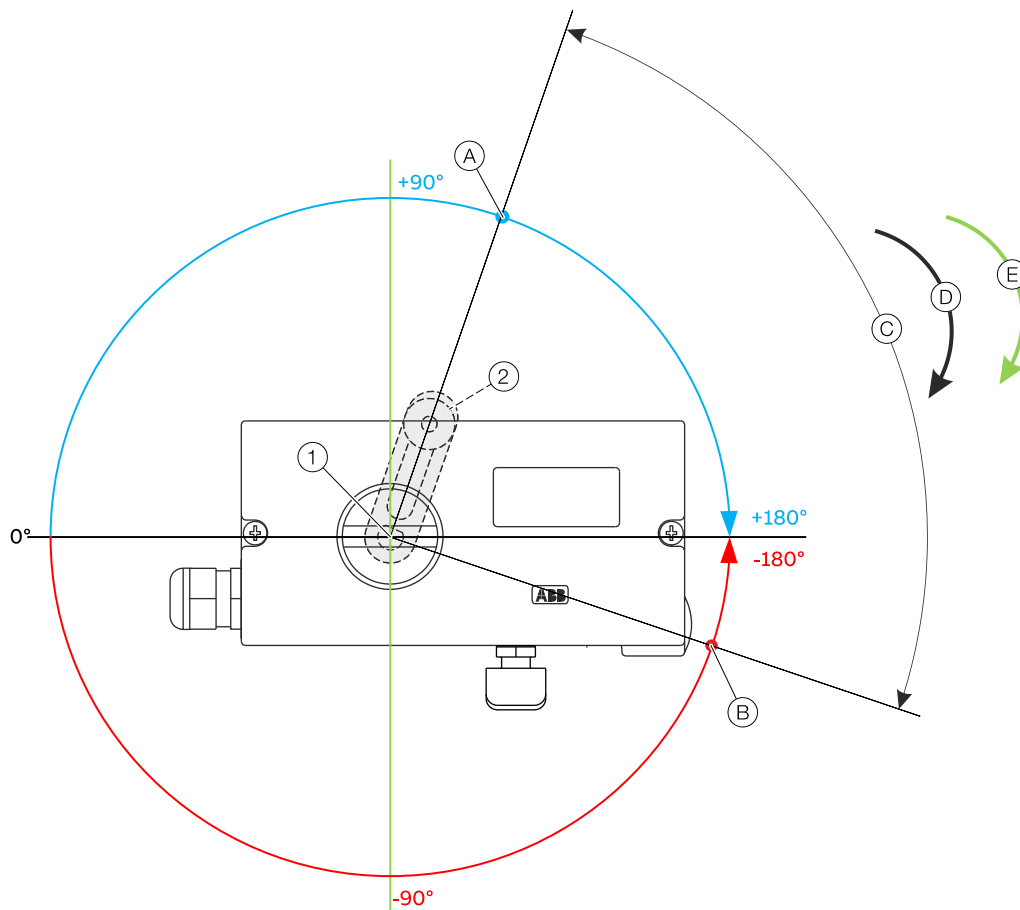

- ① Device feedback shaft
- ② Lever
- (A) Operating range 100% opening degree, OUT1 = supply pressure
- (B) Operating range 0% opening degree, OUT1 = ambient pressure
- (C) Operating range of the valve/actuator, parameter "P6.0 – MIN_VR" and "P6.1 – MAX_VR".
For rotary actuators, the operating range within each position can be up to 340°.
- (D) Rotational direction for parameter "P6.3 – SPRNG_Y2 = CLOCKWISE" (When venting OUT 1, the device feedback shaft ① turns clockwise).
- (E) Rotational direction for parameter "P6.7 – ZERO_POS = CLOCKWISE" (When venting OUT 1, the device feedback shaft ① turns clockwise).



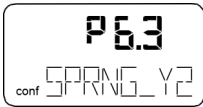

Figure 1: Measurement and operating range with contactless position feedback (example)

Manual configuration of the parameters

Note

For detailed information on the parameterization, consult the separate configuration and parameterization instructions “COI/TZIDC/TZIDC-200”.

The following parameters must be configured:

Parameter	Description
	Selection of actuator type <ul style="list-style-type: none"> • ROTARY: Part-turn actuator • LINEARY: Linear actuator
	Operating range end position minimum
	Operating range end position maximum
	Rotational direction of the spring effect or rotational direction at OUT2 under pressure. <ul style="list-style-type: none"> • CLOCKWISE: Rotational direction clockwise • CTCLOCKWISE: Rotational direction counterclockwise
	Rotational direction to reach 0% position of the actuator. <ul style="list-style-type: none"> • CLOCKWISE: Rotational direction clockwise • CTCLOCKWISE: Rotational direction counterclockwise

NOTICE

Damage of actuators / valves or impairment of the regulator function

In cases of incorrect parameterization, in particular of parameter **P6.3** (SPRNG_Y2) and **P6.7** (ZERO_POS), damage to actuators/valves or an impairment of the regulator function may occur.

- Ensure that the configuration of parameters is performed in accordance with the following method.

Procedure

1. Activate the safety position via parameter **P11.0** (FAIL_POS).
2. Reset the positioner via parameter **P11.1** (FACT_SET) to the factory setting.
3. Save the changes via parameter **P11.5** (EXIT) in the non-volatile memory.
4. Select the actuator type via parameter **P6.2** (ACTUATOR).
 - ROTARY: Rotary actuator or gear rack actuator.
 - LINEARY: Linear actuator
5. Select parameter **P6.0** (MIN_VR).
 - Move the actuator by pressing the **↓** button to the 0% position (OUT1 depressurized).
 - Press and hold the **ENTER** button until the countdown is finished (MIN_SET). The position is copied as MIN_VR.
 - Briefly press the **ENTER** button. The set limit value is displayed for 2 seconds (MIN_SAVE).
 - Note the rotational direction (clockwise/counterclockwise) of the actuator and whether the actuator rotates into the 0% direction (yes/no).
6. Select parameter **P6.1** (MAX_VR).
 - Move the actuator by pressing the **↑** button to the 100% position (OUT2 depressurized).
 - Press and hold the **ENTER** button until the countdown is finished (MAX_SET). The position is copied as MAX_VR.
 - Briefly press the **ENTER** button. The set limit value is displayed for 2 seconds (MAX_SAVE).
7. Select parameter **P6.7** (ZERO_POS).
 - If the actuator is moved into the 0% position when configuring **P6.0** (MIN_VR), position the parameter in the relevant rotational direction (CLOCKWISE / CTCLOCKWISE).
8. Select parameter **P6.3** (SPRNG_Y2).
 - Now position the parameter in the rotational direction determined during the configuration of **P6.0** (MIN_VR) (CLOCKWISE / CTCLOCKWISE).
9. Select parameter **P6.8** (EXIT) to return to the operational level.
 - Select NV_SAVE to save the configurations in the non-volatile memory.
 - Select CANCEL to reject the configurations in the non-volatile memory.
10. Check the activation of the actuator. If the control behavior is incorrect, check the parameterization in accordance with these instructions and perform it again if required.

Notes

Notes

ABB Measurement & Analytics

For your local ABB contact, visit:
www.abb.com/contacts

For more product information, visit:
www.abb.com/positioners

We reserve the right to make technical changes or modify the contents of this document without prior notice. With regard to purchase orders, the agreed particulars shall prevail.

ABB does not accept any responsibility whatsoever for potential errors or possible lack of information in this document.

We reserve all rights in this document and in the subject matter and illustrations contained therein. Any reproduction, disclosure to third parties or utilization of its contents – in whole or in parts – is forbidden without prior written consent of ABB.