

## AV1 and AV2

# Characterizable pneumatic and electro-pneumatic positioners



Pneumatic and electro-pneumatic positioners built on proven performance for demanding process conditions

### Measurement made easy

— Characterizable analog positioners

## Introduction

AV characterizable pneumatic positioners are control devices that satisfy a wide range of applications. They provide fast, sensitive and accurate positioning of pneumatic single- or double-acting, linear or rotary motion actuators. A mechanical connection from the actuator to a position feedback cam in the positioner establishes actual position. Three characterized segments on one cam provide application flexibility by establishing various relationships between input signal and actuator position. The relationships provided by the segments are square root, linear and square.

## For more information

The Operating Instruction and Data Sheet for the AV1 and AV2 characterizable pneumatic positioners are available for free download from:

[www.abb.com/measurement](http://www.abb.com/measurement)

or by scanning this code:



---

Data Sheet

[DS/AV12-EN](#)

Operating Instruction

[OI/AV12](#)

---

## Contents

General information and instructions . . . . .	2
Specification . . . . .	3
Agency Approval . . . . .	5
Component Material List . . . . .	5
Product identification . . . . .	6
Mounting the Positioner. . . . .	7
Tubing Connections . . . . .	8
Electrical Connections. . . . .	10
Calibration. . . . .	12

## General information and instructions

These instructions are an important part of the product and must be retained for future reference. Installation, commissioning, and maintenance of the product may only be performed by trained specialist personnel who have been authorized by the plant operator accordingly. The specialist personnel must have read and understood the manual and must comply with its instructions.

For additional information or if specific problems occur that are not discussed in these instructions, contact the manufacturer. The content of these instructions is neither part of nor an amendment to any previous or existing agreement, promise or legal relationship.

## Introduction

This document is intended for control engineers with in-depth knowledge of positioners and positioner applications. The quick start guide highlights the major points of installation and calibration. Detailed installation and calibration information is contained in the Operating Instruction (OI/AV12). It is strongly recommend to download and use the Operating Instruction manual for initial setup and operation.

## Trademarks and Registrations

Registrations and trademarks used in this document include:

	Registered trademark of
® Delrin	E.I. DuPont de Nemours Company, Incorporated
® Dow Corning	Dow Corning Corporation
® Lexan	General Electric Company, GE Plastics Division
® Monel	International Nickel Company
® Noryl	General Electric Company, GE Plastics Division
® PowerRac	DeZurik, a Unit of General Signal
® Rynite	E.I. DuPont de Nemours Company, Incorporated
® Teflon	E.I. DuPont de Nemours Company, Incorporated
® Valox	General Electric Company, GE Plastics Division
® Viton	E.I. DuPont de Nemours Company, Incorporated

## Contacting the Factory

Should assistance be required with any of the company's products, contact the following:

Telephone: 1-800-HELP-365

E-Mail: [automationsupport@us.abb.com](mailto:automationsupport@us.abb.com)

## Warnings

The warnings in these instructions are structured as follows:

### DANGER

The signal word '**DANGER**' indicates an imminent danger. Failure to observe this information will result in death or severe injury.

### WARNING

The signal word '**WARNING**' indicates an imminent danger. Failure to observe this information may result in death or severe injury.

### CAUTION

The signal word '**CAUTION**' indicates an imminent danger. Failure to observe this information may result in minor or moderate injury.

### NOTICE

The signal word '**NOTICE**' indicates potential material damage.

**Note** - '**Note**' indicates useful or important information about the product.

### WARNING

Do not install, maintain or operate this equipment without reading, understanding and following the proper factory-supplied instructions and manuals, otherwise injury or damage may result.

### WARNING

POSSIBLE PROCESS UPSETS.

Maintenance must be performed only by qualified personnel and only after securing equipment controlled by this product. Adjusting or removing this product while it is in the system may upset the process being controlled. Some process upsets may cause injury or damage.

## Return of Equipment

All equipment being returned to the factory for repair must be free of any hazardous materials (acids, alkalis, solvents, etc.). A Material Safety Data Sheet (MSDS) for all process liquids must accompany returned equipment. Contact the factory for authorization prior to returning equipment.

## Specification

Table 1-1 provides performance specifications of the Type AV1 and Type AV2 positioners. Tables 1-2 and 1-3 provide performance specifications for the position transmitters.

Table 1-1. Type AV1/2 Positioner Specifications<sup>1</sup>

Property	Characteristic/Value
Input range AV11 and AV15 AV12 and AV16 AV23 and AV27	20.7 to 103.4 kPa (3.0 to 15.0 psig) 20.7 to 186.2 kPa (3.0 to 27.0 psig) 4 to 20 mA
Input impedance (Type AV2 only) Nominal Maximum	215 Ω at 22°C (72°F) 245 Ω at 60°C (140°F)
Standard stroke range (cam selection) AV__1____ AV__2____	12.7 to 50.8 mm (0.5 to 2.0 in.) linear, rotary input 45° 25.4 to 101.6 mm (1.0 to 4.0 in.) linear, rotary input 90°
Gain	2 adjustment levels by changing gain hinge spring. Refer to the flow gain curves as shown in Figures 1-3 and 1-4 for standard and high gain units.
Accuracy <sup>2</sup> AV1 AV2	0.80% of span maximum 0.90% of span maximum
Resolution AV1 AV2	0.09% of span maximum 0.30% of span maximum
Hysteresis <sup>2</sup> AV1 AV2	0.45% of span maximum 0.70% of span maximum
Repeatability <sup>2</sup> AV1 AV2	0.12% of span maximum 0.50% of span maximum
Deadband <sup>2</sup> AV1 AV2	0.12% of span maximum 0.30% of span maximum
Linearity <sup>2</sup>	0.70% of span maximum
Supply pressure	172 to 1034 kPa (25 to 150 psig) NOTE: Minimum supply pressure should be 34.4 kPa (5.0 psig) above operating pressure required by actuator.
Supply pressure effect	0.05% per 6.9 kPa for ±69 kPa change (0.05% per 1.0 psi for ±10 psig change)
Capacity	(maximum capacity exhausting to atmosphere) Refer to Figure 1-1.
Air consumption	Refer to Figure 1-2.

Table 1-1. Type AV1/2 Positioner Specifications<sup>1</sup> (continued)

Property	Characteristic/Value
Vibration effect <sup>2</sup>	<2.0% error for: 5 to 15 Hz at peak-to-peak constant displacement of 4 mm (0.16 in.) 15 to 120 Hz at accelerations to 2 Gs
Pneumatic connections	1/4 -NPT on supply, signal and output connections 1/8 -NPT on pressure gauges
Materials of construction Enclosure Pilot valve	Aluminum and <0.5% magnesium 303 stainless steel
Enclosure classification Standard  AV_____N	NEMA 3R classification when vent hole is protected from rain using rain elbow (½-NPT street elbow, refer to Figure 3-1).  NEMA 4X when installed per drawing C258567. Also see Figure B-11B
Weight AV1 AV2 (standard) AV2 (explosionproof)	1.84 kg (4.06 lbs) 2.32 kg (5.11 lbs) 2.95 kg (6.51 lbs)
Temperature limits Operating AV11/2 AV15/6 AV2 Storage AV11/2 AV15/6 AV2	-40°C to 82°C (-40°F to 180°F) <sup>3</sup> -20°C to 127°C (-4°F to 250°F) <sup>3</sup> -20°C to 82°C (-4°F to 180°F) <sup>3</sup> -40°C to 93°C (-40°F to 200°F) -20°C to 127°C (-4°F to 250°F) -20°C to 82°C (-4°F to 180°F)
Humidity limits Operating Storage	0% to 95% noncondensing 0% to 95% noncondensing

**NOTES:**

1. Performance testing performed on a ABB Type UP10 actuator.
2. Tested according to ISA-S75.13-1989
3. For operation below 4.4°C (40°F), dew point of the supply air must be 10°C (18°F) lower than the lowest expected operating temperature.

SPECIFICATIONS SUBJECT TO CHANGE WITHOUT NOTICE.

...Specification

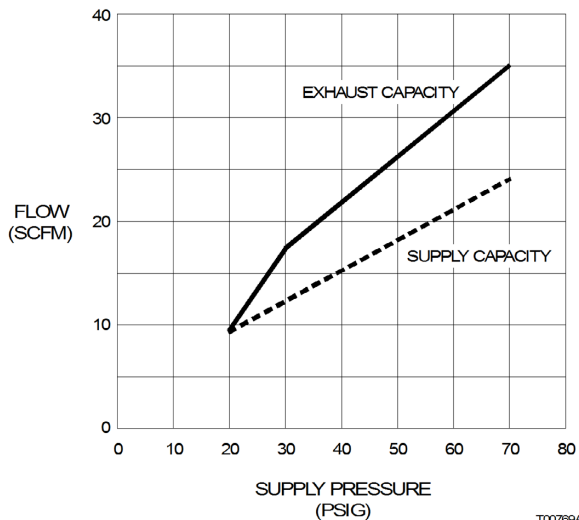

Figure 1-1. Capacity (Exhaust to Atmosphere)

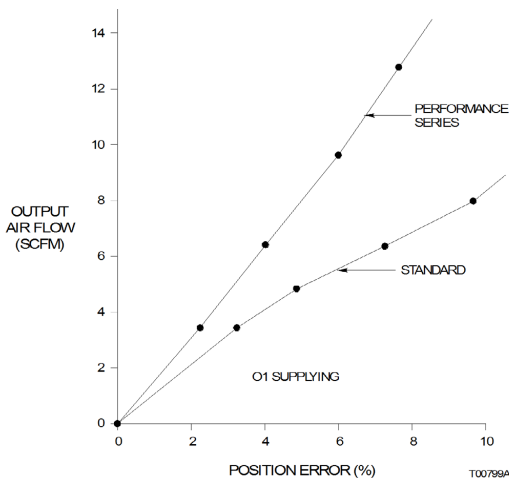

Figure 1-4. Expanded First Quadrant View of Figure 1-3

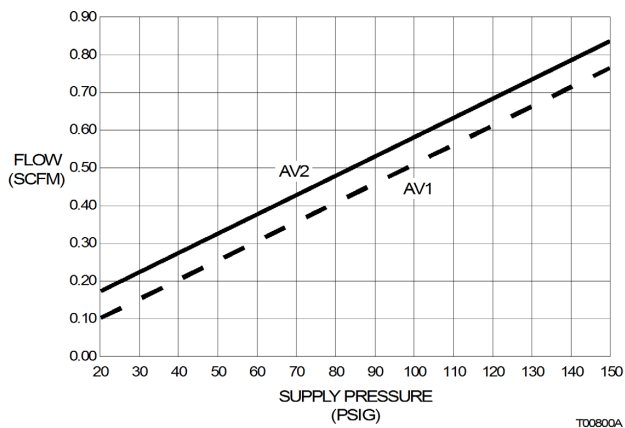

Figure 1-2. Air Consumption

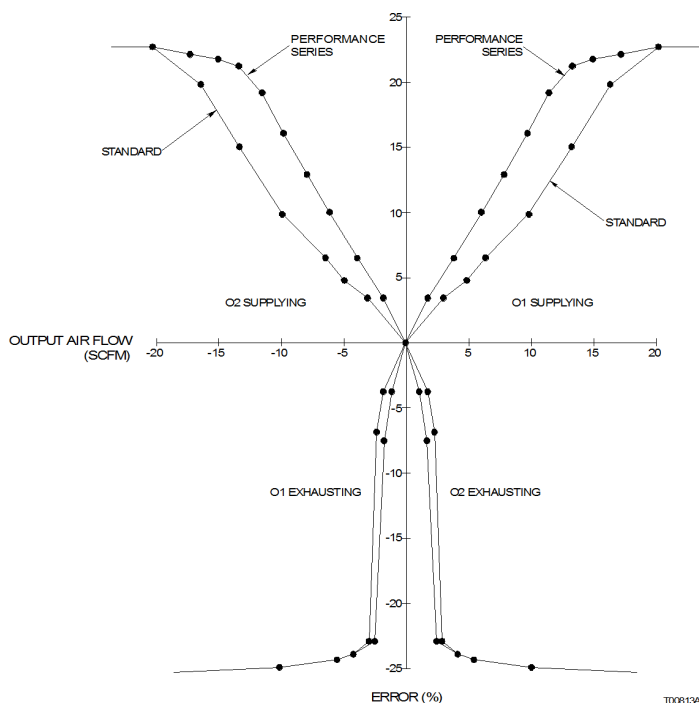

Figure 1-3. Output Air Flow vs. Error Signal — Standard and Performance Series

Table 1-2. Type AV \_\_\_\_\_ 1 \_\_ Potentiometric Position Transmitter Specifications

Property	Characteristic/Value
Total resistance	2000 $\Omega$ , $\pm 20\%$
Power rating	1 W up to 70°C (158°F), 0 W at or above 125°C (257°F)
Wiper rate of change	9.9 $\Omega$ nominal per degree of cam rotation
Temperature effect	0.05% (500 ppm) per °C (0.03% (278 ppm) per °F) maximum
Maximum voltage	35 VDC or 30 VAC across the potentiometer ends
Temperature limits	
Operating	-40°C to 82°C (-40°F to 180°F)
Storage	-40°C to 93°C (-40°F to 200°F)

Table 1-3. Type AV \_\_\_\_\_ 2 \_\_ 4 to 20-mA Position Transmitter Specifications

Property	Characteristic/Value
Supply voltage	16 to 34 VDC
Output signal	4 to 20 mA
Output loading	500 $\Omega$ at 24 VDC, 1000 $\Omega$ at 34 VDC
Accuracy	<0.6% of span (maximum)
Hysteresis	<0.5% of span (maximum)
Ambient temp effect	<0.063% per °C (<0.035% per °F)
EMI/RFI effect	<1.5% maximum at 10 V/m field strength, 20 to 450 MHz
Temperature limits	
Operating	-40°C to 82°C (-40°F to 180°F)
Storage	-40°C to 93°C (-40°F to 200°F)

## Agency Approval

## Component Material List

Table 1-4. Agency Approvals<sup>1</sup>

Nomenclature	Approval/Certification
AV1 and AV23	Factory Mutual Research (cFM <sub>US</sub> ): FM Approvals - FM16US0321 FM Approvals Canada - FM16CA0160  Approved as nonincendive for: Class I, Div 2, Groups A, B, C, D / T5 Ta = 40°C Class II, Div 2, Groups E, F and G / T5 Ta = 40°C Class III, Div 2 / T5 Ta = 40°C
AV27__0__	Install per ABB TEIP11 - I/P Signal Converter Refer to OI/TEIP11/TEIP11-PS  Factory Mutual Research (FM) - Suitable for: Explosion-proof for Class I, Div 1, Grps B, C and D Dust-ignition-proof for Class II and III, Div 1, Grps E, F, G Intrinsically safe for Class I, II and III, Div 1, Grps A- G  Canadian Standards Association (CSA) - Suitable for: Explosion-proof for Class I, Div 1, Grps B, C and D Dust-ignition-proof for Class II and III, Div 1, Grps E, F, G Intrinsically safe for Class I, II and III, Div 1, Grps A- G
All	Complies with the EC directive for CE conformity. 2014/30/EU - Electromagnetic Compatibility EMC 2011/65/EU & 2015/863/EU - RoHS Directive

**NOTES:**

1. Hazardous locations approvals for use in flammable atmospheres are for ambient conditions of -25°C to 40°C (-13°F to 104°F), 86 to 106 kPa (12.5 to 15.7 psig) with a maximum oxygen concentration of 21%.

Table 1-5. Component Material List

Component	Material
Housing	Aluminum
Cover	Aluminum
Inserts	Lamond (thermoplastic elastomer)
Window	Lexan® (polycarbonate)
Screws	Stainless steel
Range spring	302 stainless steel
Pilot valve (stem & body)	303 stainless steel
Gain hinge spring	302 stainless steel
Cam	302 stainless steel
Cam shaft	303 stainless steel
Bearings	Bronze
Cam follower arm	Aluminum
Bearing	Stainless steel
Shaft	303 stainless steel
Spring arm	Aluminum
Zero adjustment nut	Aluminum
Indicator	Valox® — unreinforced (polybutylene terphthalate)
Tubing	Silicone
Drive arm	Aluminum
Teflon® washers	Teflon
Fasteners	Steel/stainless steel
Signal connector	Nylon
Diaphragms	
All except Types AV15 & AV16	Buna-N with Dacron fabric
Types AV15 and AV16	Fluorosilicone with Dacron fabric
Diaphragm plastic parts	Rynite® (FR-530) polyethylene terphthalate
Gauge block (optional)	Aluminum
O-rings	
All except Types AV15 & AV16	Buna-N
Types AV15 and AV16	Viton®
Manifold (optional)	Aluminum
Adhesive	Epoxy
Handle	Rynite
Plate	Aluminum
Plug	Stainless steel
Valve	Aluminum
Valve handle	Rynite
Position transmitter (AV____1/2__)	
Gears	Delrin® (coolymer acetal)
Gear hub	Brass
Additional Type AV2 comps	
Tubing	Nylon
I/P converter	Copper
	Copper clad glass laminate
	Monel® 405, Nickel-iron
	Noryl®, Polyethylene, Zinc
	Rare earth magnet, Polyester
	magnet wire

## Product identification (Nomenclature)

Table 1-6. Nomenclature

Position	1	2	3	4	5	6	7	8	9	Characterizable Positioners
Type	A	V	-	-	-	-	-	-	-	
			1							Characterizable Pneumatic Positioner <sup>1</sup>
			2							Characterizable 4 to 20-mA Input Positioner <sup>2</sup> (actuator moves to 0% or 100% upon loss of signal)
				1						Input Signal 20.7 to 103.4 kPa (3.0 to 15.0 psig) (Type AV1)
				2						20.7 to 186.2 kPa (3.0 to 27.0 psig) (Type AV1)
				3						4 to 20 mA (Type AV2)
				5						20.7 to 103.4 kPa (3.0 to 15.0 psig), high temperature applications (Type AV1) <sup>3</sup>
				6						20.7 to 186.2 kPa (3.0 to 27.0 psig), high temperature applications (Type AV1) <sup>3</sup>
				7						4 to 20 mA with explosionproof I/P converter (NEMA 7) (Type AV2) <sup>4</sup>
					1					Stroke/Rotary Motion (cam selection) 12.7 to 50.8 mm (0.5 to 20.0 in.) or 45° rotary motion
					2					25.4 to 101.6 mm (1.0 to 4.0 in.) or 90° rotary motion
						0				Manifold (includes filters)/Gauge Block No manifold
							1			Manifold with equalizing valve, filters and gauge ports (required for double acting actuators with manual override)
							3			Gauge block (gauge port only) <sup>3</sup>
								0		Position Transmitter None (must be 0 for Types AV15, AV16 and AV27)
								1		Potentiometric resistive output
								2		4 to 20-mA output
									0	Drive Shaft Standard with feedback arm for linear motion
									1	0.500-in. square end
									2	0.342-in. square end for older DeZurik actuators
									3	0.250 in. across flats (UP1 and UP2 after August, 1995)
									4	0.375 in. square for DeZurik PowerRac® actuators
									5	0.156 in. across flats for NAMUR rotary actuators
										Other Options
									0	Standard (no other options)
									N	NEMA 4X enclosure rating (when installed per drawing C258567) <sup>5</sup>
									P	Performance Series — high pneumatic gain for large actuators

### NOTES:

1. AV1 \_\_\_\_\_ is cFMus approved only for general purpose and non-incendive installations.
2. AV23 \_\_\_\_\_ is cFMus approved only for general purpose and non-incendive applications.  
AV27 \_\_\_\_\_ suitable for Intrinsically safe and Explosion Proof with integrated FM/CSA approved ABB I/P converter.
3. High temperature Type AV1 positioners are only available without manifolds or position transmitters; however, gauge blocks are permitted.
4. Explosionproof Type AV27 positioners are not available with position transmitters or manifolds.
5. The Type AV\_\_\_\_\_N positioner comes with a NEMA 4X housing. To maintain the NEMA 4X classification, the positioner shall be installed per drawing C258567 and suitable piping shall be attached to the vent opening and vented in a manner to preclude the entrance of water under pressure, as from a hose. Additionally, the conduit connections shall be suitable for a NEMA 4X rating.

## Installation

The Type AV positioner can be used with double acting or single acting actuators.

## Mounting the Positioner

Due to the wide range of applications that the Type AV positioner is suited for, only general information about mounting is provided. Use the following procedure to mount the positioner.

Install the positioner as required on the actuator. Figures B-1 and B-2 show typical mounting arrangements. Use the following procedure for mounting guidelines.

**NOTE:** If the actuator is equipped with a Type AV positioner as ordered, verify that all the connections are secure and make any adjustments as required.

1. Set the actuator at the zero position. Connect the adjustable linkage to the drive arm. The drive arm holes correspond to stroke length of the actuator. Refer to Figure B-3 for the stroke length for each drive arm hole.

2. Install the cam (black, direct acting; or red, reverse acting) that will provide the required direction of rotation.

**NOTE:** Cams have three mounting holes:

A - square root; B - linear; C - square.

Each mounting hole is star shaped so the cam can be rotated in 45° increments to suit the application.

3. With the actuator in the closed position, adjust the connecting linkage so that the zero radial line on the cam intersects the center of the cam roller (Fig. B-4).

4. Lock all linkage components in place.

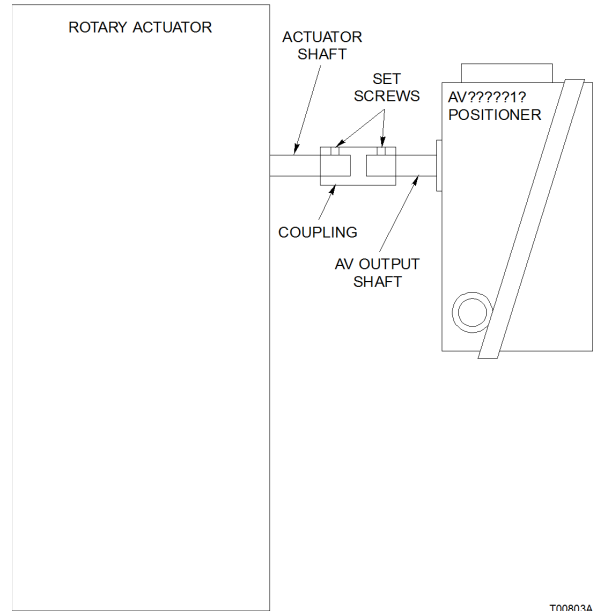

Figure B-2. Mounting Using Direct Coupling (Typical)

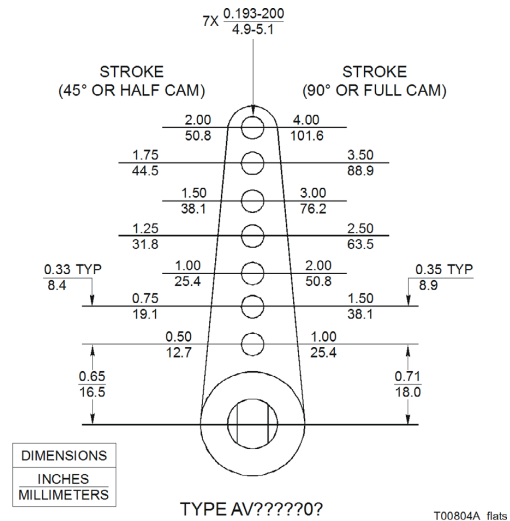

Figure B-3. Drive Arm Connections

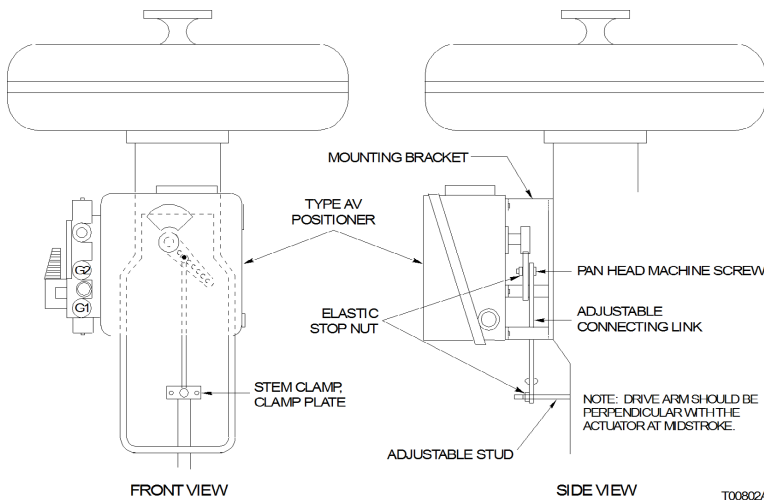

Figure B-1. Mounting Using Linkage (Typical)

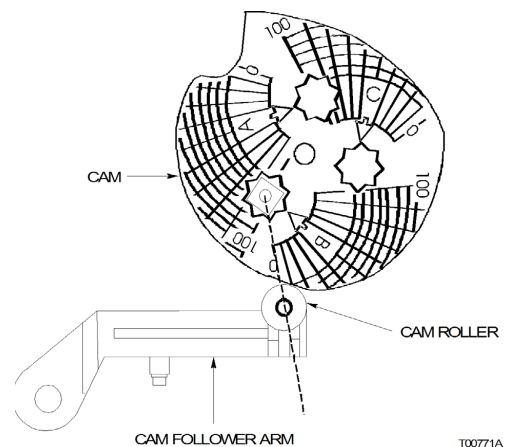

Figure B-4. Cam Roller Alignment

## Tubing Connections

Type AV positioners are available with (Type AV\_\_1\_\_ and AV\_\_2\_\_) or without (AV\_\_0\_\_) manifolds (see Fig. B-5). The following outlines supply air information and describes the piping connections.

1. Connect the required supply air to connection S (Fig. B-5).  
NOTE: Maximum torque for ¼-NPT fittings is 13.6 Nm (10.0 ft-lbs).
2. Based on the positioner type, perform one of the following steps (Fig. B-5):
  - AV11 and AV15: Connect 20.7 to 103.4-kPa (3.0 to 15.0-psig) instrument signal to connection I.
  - AV12 and AV16: Connect 20.7 to 186.2-kPa (3.0 to 27.0-psig) instrument signal to connection I.
  - AV2: Connection I is not used and should be plugged. If it is not plugged, do so at this time.
 NOTE: Use liquid or paste pipe sealant to seal the connection. Maximum torque for ¼-NPT fittings is 13.6 Nm (10.0 ft-lbs).

3. Connect the output ports O1 and O2 as required to provide the desired direction of rotation. Figures B-6, B-7, B-8 and B-9 show a single acting tubing example, and Figure B-10 shows a double acting tubing example.  
NOTE: The piping arrangements shown in Figures B-6, B-7, B-8, B-9 and B-10 are general examples and may not reflect the arrangement required for the application.

4. Install -NPT permanent instrument gauges to the gauge ports if desired or for calibration requirements.

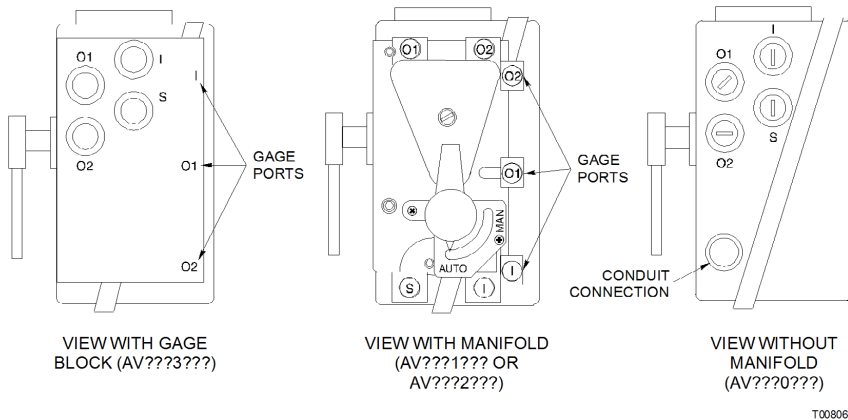

Figure B-5. Port Locations

## CAUTION

Do not exceed the maximum supply pressure of 1034 kilopascals (150 pounds per square inch gauge). Exceeding this pressure could cause equipment damage.

NOTE: The minimum supply pressure should be 34.4 kilopascals (5 pounds per square inch gauge) above the operating pressure required by the actuator.

For long-term, trouble free operation, it is recommended that the supply air be of instrument quality and conform to the ANSI/ISA-7.0.01-1996 standard, the particle size in the supply line should not be greater than 3.0 microns.

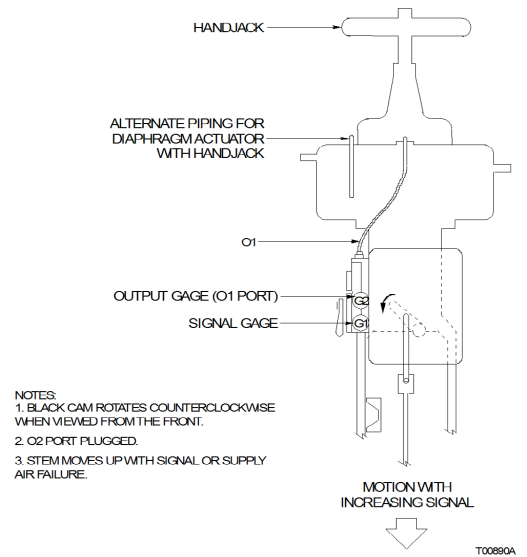

Figure B-6. Direct Acting, Top Loaded, Single Acting Tubing Example

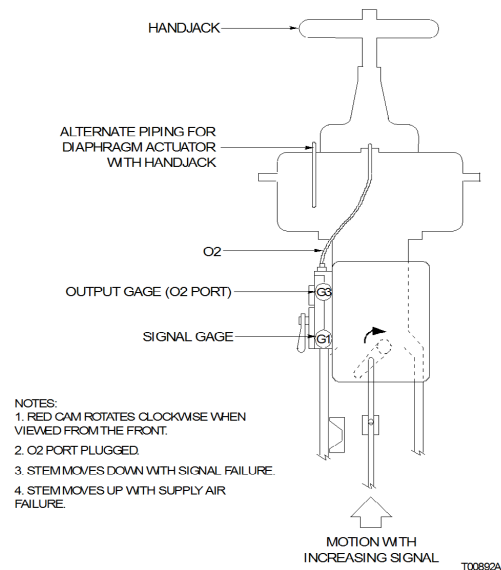

Figure B-7. Reverse Acting, Top Loaded, Single Acting Tubing Example

### ...Tubing Connections

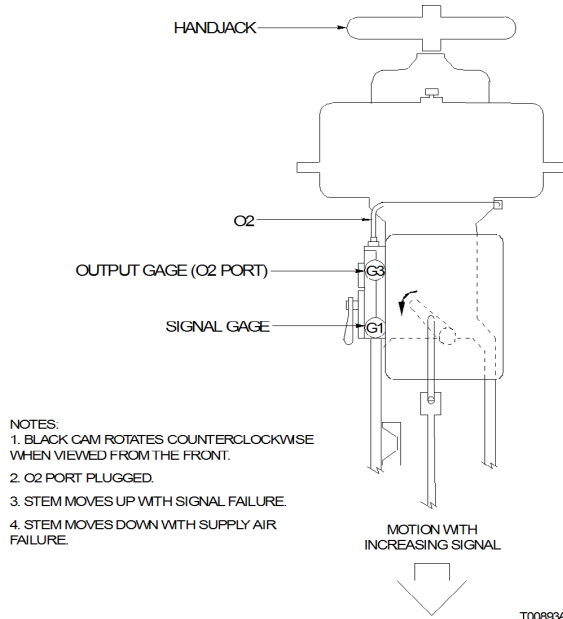

Figure B-8. Direct Acting, Bottom Loaded, Single Acting Tubing Example

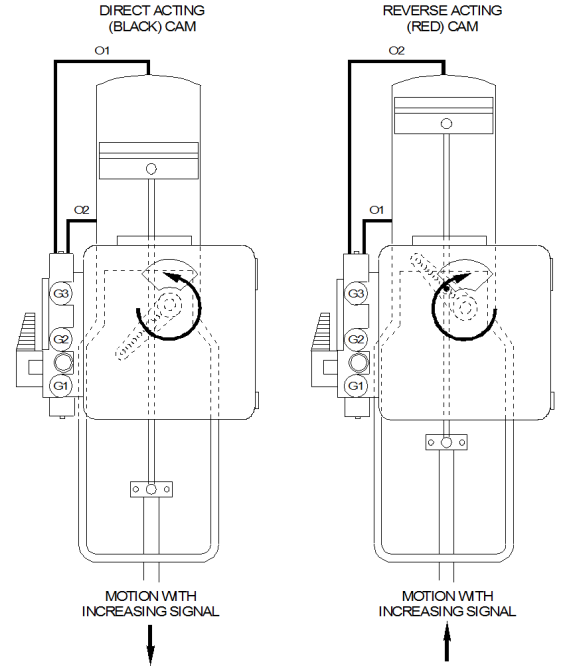

Figure B-10. Double Acting Tubing Example

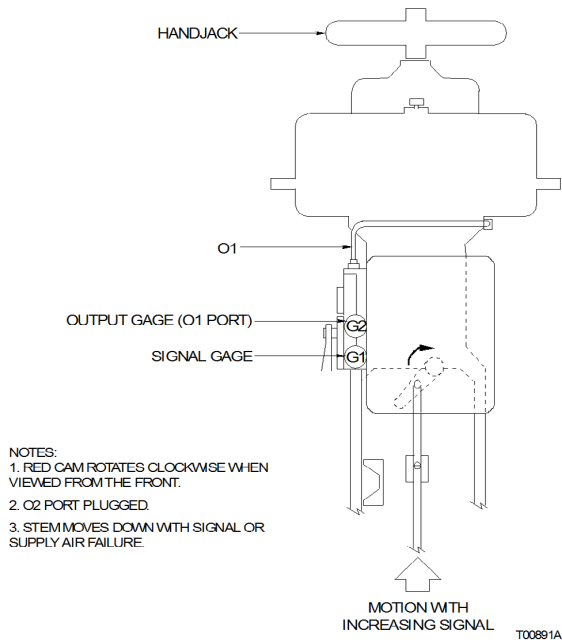

Figure B-9. Reverse Acting, Bottom Loaded, Single Acting Tubing Example

## Electrical Connections

### ⚠ WARNING

Before mounting or installing positioner, check nameplate data to make certain positioner is suitable for application desired. DO NOT AT ANY TIME EXCEED THE RATINGS LISTED ON THE NAMEPLATE.

### WIRING REQUIREMENTS

Under ideal conditions, the use of conduit and shielded wire may not be required. However, to avoid noise problems, it is recommended that wiring be enclosed in conduit. Just prior to entering the housing, rigid conduit should be terminated and a short length of flexible conduit should be installed to reduce any stress.

### RADIO FREQUENCY INTERFERENCE

Most electronic equipment is influenced by radio frequency interference (RFI). Caution should be exercised with regard to the use of portable communications equipment in the area. ABB recommends posting appropriate signs in the plant. Refer to the Site Planning and Preparation instruction for additional information on RFI.

### GROUNDING

Grounding positioners should be done in accordance with local electrical codes (in U.S, National Electrical Code, ANSI/ NFPA 70. In Canada, Canadian Electrical Code, CSA c22.1). A grounding screw is provided inside the AV enclosure for grounding.

#### NOTES:

1. The grounding screw located inside the AV enclosure is a safety ground & should not be used to ground the shielded pair.
2. The positioner must be grounded to avoid ground loop conditions.

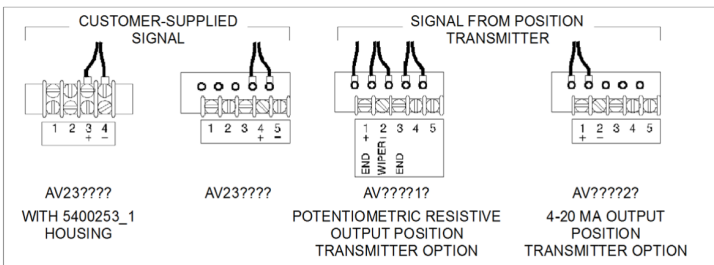

Figure B-11A. Electrical Connections

T00928A

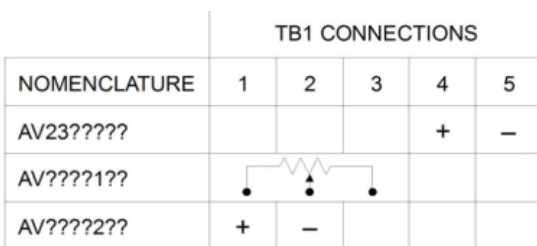

Figure B-11. Wiring Connections

T00807A

## Type AV1 Positioner Wiring

This section applies to the following positioners:

- Type AV1\_\_\_\_1\_\_
- Type AV1\_\_\_\_2\_\_

#### NOTE:

1. For Type AV1\_\_\_\_0\_\_ no electrical wiring is required.
2. If using a twisted shielded pair for signal wiring, ground one end of the shielded pair at the source. Trim the other end of the pair, located inside the enclosure, so that bare wires are not exposed.

1. If equipped with optional 4 to 20-mA position transmitter (Type AV1\_\_\_\_1\_\_), connect a 24-VDC power supply in series with the required output load (500 Ω at 24 VDC, 1000 Ω at 34 VDC) to terminals TB1-1 (+) and TB1-2 (-) (Fig. B-11). Refer to Appendix A of Installation Manual for detailed information about position transmitters.

2. If equipped with optional potentiometric position transmitter (Type AV1\_\_\_\_2\_\_), connect a power supply (maximum 35 VDC or 30 VAC) across TB1-1 and TB1-3. Use the signal across TB1-1 and TB1-2 or TB1-2 and TB1-3 for position transmitter feedback. Refer to Appendix A for detailed information about position transmitters.

NOTE: Route the wiring inside the positioner so it does not become entangled with moving parts. A cable clamp (Fig. B-12) is provided inside the positioner so entanglement can be avoided.

## Type AV2 Positioner Wiring

This section covers the wiring connections for Type AV2 positioner:

1. Connect the 4 to 20mA position demand signal wires to terminals TB1-4 (+) and TB1-5 (-) of the terminal block (Fig. B-11). If you have a Type AV2\_\_\_\_0\_\_ positioner, go to Step 4.

NOTE: If using a twisted shielded pair for signal wiring, ground one end of the shielded pair at the source. Trim the other end of the pair, located inside the enclosure, so that bare wires are not exposed.

2. If equipped with an optional 4 to 20-mA position transmitter (AV2\_\_\_\_2\_\_), connect a 24-VDC power supply in series with the required output load (500 Ω at 24 VDC, 1000 Ω at 34 VDC) to terminals TB1-1 (+) and TB1-2 (-).

3. If equipped with optional potentiometric position transmitter (AV2\_\_\_\_1\_\_), connect a power supply (maximum 35 VDC or 30 VAC) across TB1-1 and TB1-3. Use the signal across TB1-1 and TB1-2 or TB1-2 and TB1-3 for position transmitter feedback. Refer to Appendix A of Installation Manual for detailed information about position transmitters.

NOTE: Route the wiring inside the positioner so it does not become entangled with moving parts. A cable clamp (Figure B-12) is provided inside the positioner so entanglement can be avoided.

### ... Electrical Connections

#### Explosionproof I/P Option

The Type AV27 positioner employs an explosionproof I/P converter that is mounted to an adapter block manifold. The adapter block manifold is bolted to the outside of the main positioner housing. The unit is a Type AV12 positioner with the electric to pneumatic (4 to 20 mA / 20.7 to 103.4-kilopascal (3.0 to 15.0-pounds per square inch gauge)) conversion occurring within the externally mounted I/P converter.

The 4 to 20 mA input signal wires shall be connected through an explosionproof conduit entrance on the I/P converter. If no electrical connections are made within the main housing, the entire positioner can be considered suitable for application in the hazardous locations shown on the I/P label.

Refer to Figure B-11B for the external and mounting dimensions of the Type AV27 positioner.

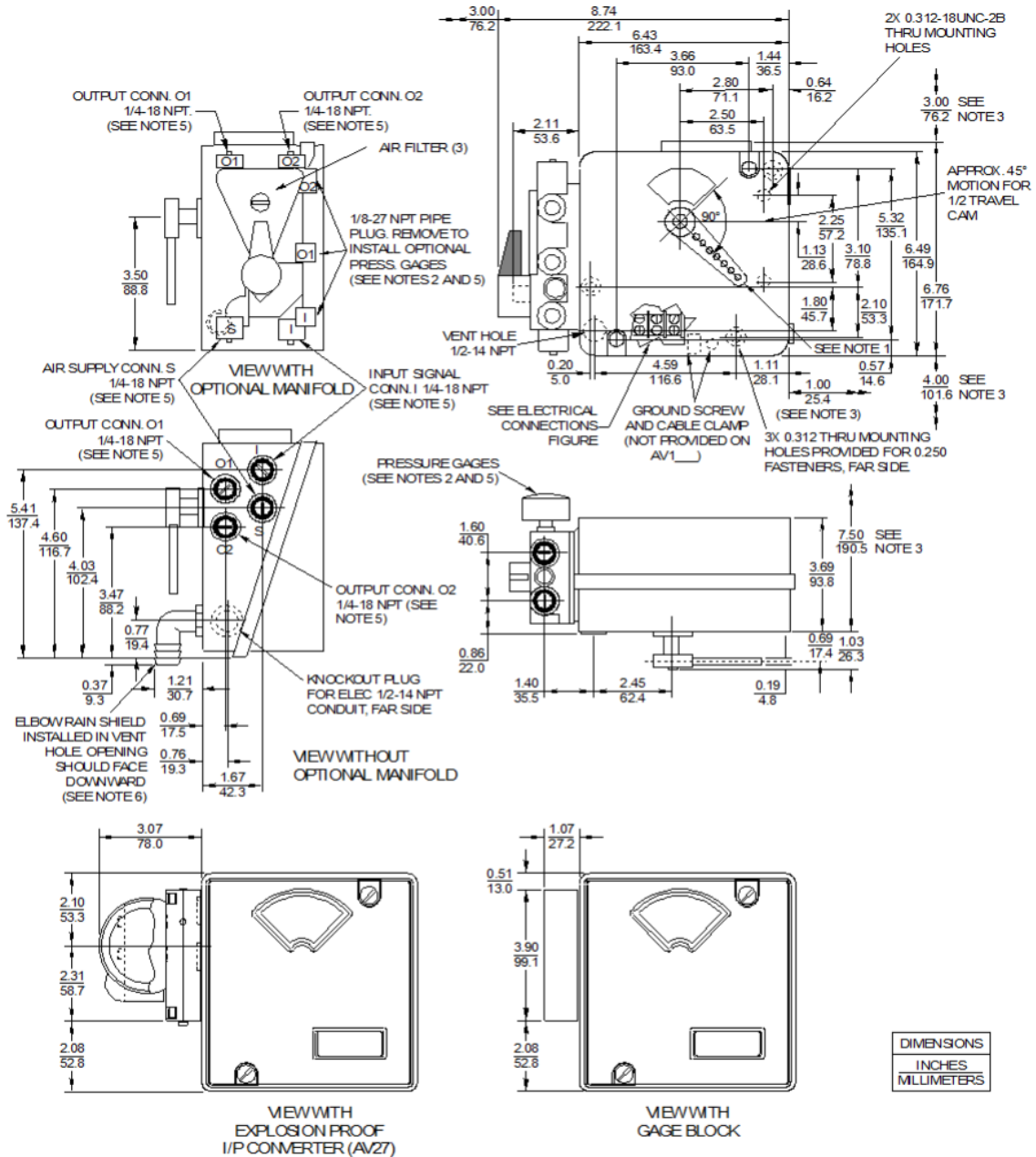

- NOTES:
1. DRIVE ARM MAY BE ROTATED IN 45° INCREMENTS RELATIVE TO POSITIONING CAM.
  2. PRESSURE GAGES ARE AVAILABLE ONLY AS AN ACCESSORY AND MUST BE INSTALLED BY THE CUSTOMER.
  3. MINIMUM CLEARANCE REQUIRED FOR ADJUSTMENTS, INSPECTION, MAINTENANCE AND OPERATION.
  4. ALL UNTOLERANCED DIMENSIONS ARE NOMINAL.
  5. USE LIQUID OR PASTE PIPE SEALANT ON FITTINGS. DO NOT USE TEFLON TAPE.

Figure B-11B. External and Mounting Dimensions

## Calibration

Table B-1 presents calibration procedures for Type AV1 and Type AV2 positioners in table format.

AV1		AV2 & AV27	
Adj	Procedure	Adj	Procedure
Zero	1. Apply 20.7 kPa (3.0 psig) input signal pressure to the positioner. The actuator should be in the closed position.	Zero	1. Turn on supply air. Apply a 4-mA input signal to the positioner. The actuator should be in the closed position.
	2. To adjust the zero, loosen the zero adjustment setscrew (Fig. B-12) using a 3/32 inch Allen wrench.		2. To adjust the zero, loosen the zero adjustment setscrew (Fig. B-12) using a 3/32 inch Allen wrench.
	3. Turn the zero adjustment nut (clockwise moves actuator toward minimum span) until the 0 radial line on the cam intersects with the center of the cam roller (Fig. B-4).		3. Turn the zero adjustment nut (clockwise moves actuator toward minimum span) until the 0 radial line on the cam intersects with the center of the cam roller (Fig. B-4).
	4. Tighten the zero adjustment setscrew.		4. Tighten the zero adjustment setscrew.
Span	1. Apply the following input signal pressures, depending on the nomenclature type: Types AV11 and AV15: 103.4 kPa (15.0 psig). Actuator should move to its full open position. Types AV12 and AV16: 186.2 kPa (27.0 psig). Actuator should move to its full open position.	Span	1. Apply a 20-mA signal to the positioner. The actuator should be in its full open position.
	2. To adjust the span, loosen the span adjustment screw (Fig. B-12) using a 3/32inch Allen wrench.		2. To adjust the span, loosen the span adjustment screw (Fig. B-12) using a 3/32 inch Allen wrench.
	3. Slide span adjustment assembly (Fig. B-12) until the actuator moves to align the 100% radial line with the center of the cam roller (toward pilot valve increases span).		3. Slide span adjustment assembly (Fig. B-12) until the actuator moves to align the 100% radial line with the center of the cam roller (toward pilot valve increases span).
	4. Tighten the span adjustment screw.		4. Tighten the span adjustment screw.

Table B-1. Calibration Procedures

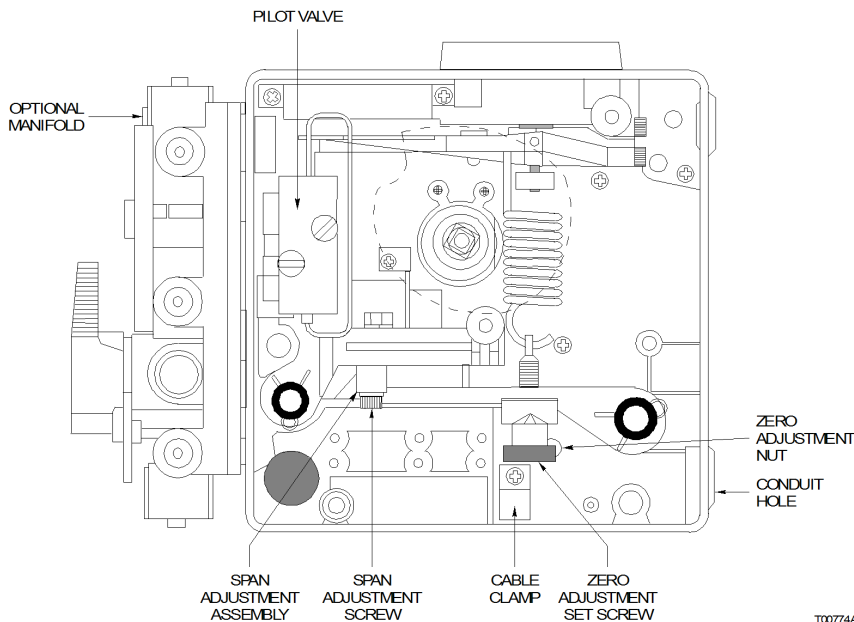

Figure B-12. Calibration Adjustments

T00774A

## Notes



---

## **ABB Measurement & Analytics**

For your local ABB contact, visit:

**[www.abb.com/contacts](http://www.abb.com/contacts)**

For more product information, visit:

**[www.abb.com/measurement](http://www.abb.com/measurement)**

---

We reserve the right to make technical changes or modify the contents of this document without prior notice. With regard to purchase orders, the agreed particulars shall prevail. ABB does not accept any responsibility whatsoever for potential errors or possible lack of information in this document.

We reserve all rights in this document and in the subject matter and illustrations contained therein. Any reproduction, disclosure to third parties or utilization of its contents – in whole or in parts – is forbidden without prior written consent of ABB.