

**JUMO**



# Information on conductivity measurement



Reinhard Manns



# Information on Conductivity Measurement

*Reinhard Manns*

## Note

This reference work has been created to the best knowledge and belief. We assume no liability for possible errors. The definitive source of information is always the operating manual for the relevant device.

## **Preface**

Conductivity measurement is an easily performed measurement technique for determining and monitoring the total salt concentration in water. It is encountered in many areas of industrial and environmental analysis. Whether it concerns cleaning the filling lines in a dairy, or protection of the cooling water system in a power station, the correct procedures always depend on the conductivity value.

This technical publication presents the basic chemical relationships and typical applications in a general, easily understood form. In addition, information will be given on the current state of technology with regard to transmitters/controllers and sensors for this process variable.

Our aim is to ensure that the "Information on conductivity measurement" is always kept fully up to date, and therefore invite our readers to provide feedback and share experience and knowledge. Any suggestions or contributions to the discussion will be most welcome.

Fulda, April 2007

Dipl.-Ing. (FH) Reinhard Manns

Dr. Jürgen Schleicher



**JUMO GmbH & Co. KG**

Moltkestraße 13 - 31

D-36039 Fulda, Germany

Phone: +49 661 6003-0

Fax: +49 661 6003-500

e-Mail: [analysenmesstechnik@jumo.net](mailto:analysenmesstechnik@jumo.net)

Internet: [www.jumo.net](http://www.jumo.net)

Reprinting permitted with source citation!

Part No.: 00411341

Book No.: FAS 624

Printed: 04.07

# Contents

---

<b>1</b>	<b>Basics</b>	<b>7</b>
1.1	General	7
1.2	Methods of measuring conductivity	8
1.2.1	General	8
1.2.2	The cell constant	9
1.2.3	AC voltage	10
1.2.4	Measurement principles	10
1.2.5	Inductive measuring cell	12
<b>2</b>	<b>Measurement</b>	<b>13</b>
2.1	Arrangement of a process installation	13
2.1.1	Measuring cells	13
2.1.2	Fittings	14
2.1.3	Transmitter/controller	14
2.1.4	Instrumentation: cable material/connecting cable	15
2.2	Commissioning the measurement system	15
2.2.1	Measurement location	15
2.2.2	Calibration/adjustment	15
2.2.3	Measurement conditions	17
2.2.4	Reference solutions	20
<b>3</b>	<b>Quality assurance</b>	<b>21</b>
3.1	Documentation	21
3.2	Maintenance	23
3.3	Problems/actions	25
3.4	Cleaning	25
3.5	On-site test options	26
3.6	Storage of the measuring cell	26
<b>4</b>	<b>Applications</b>	<b>27</b>
4.1	Wastewater treatment plants	27
4.2	Galvanizing plants	28
4.3	Beverage bottling plants	28
4.4	Power stations	29
4.5	Pharmaceuticals	31
4.6	Full desalination plants	32
4.7	Concentration measurements	33

# Contents

---

<b>5</b>	<b>Legal aspects .....</b>	<b>35</b>
<b>6</b>	<b>Source information .....</b>	<b>37</b>
<b>7</b>	<b>Appendix .....</b>	<b>39</b>
<b>7.1</b>	<b>Sample test certificate for the measuring cell .....</b>	<b>39</b>
<b>7.2</b>	<b>Sample calibration certificate for a transmitter .....</b>	<b>40</b>

## 1.1 General

The conductance or conductivity<sup>1</sup> ( $\gamma$ )<sup>2</sup> expresses how well a material conducts an electric current. With metals, it is the movement of electrons that causes the current flow. In aqueous solutions, ions take over the charge transport. Ions are formed when salts, acids, or alkalis dissolve. The more ions are present in the liquid, the better it conducts the current.

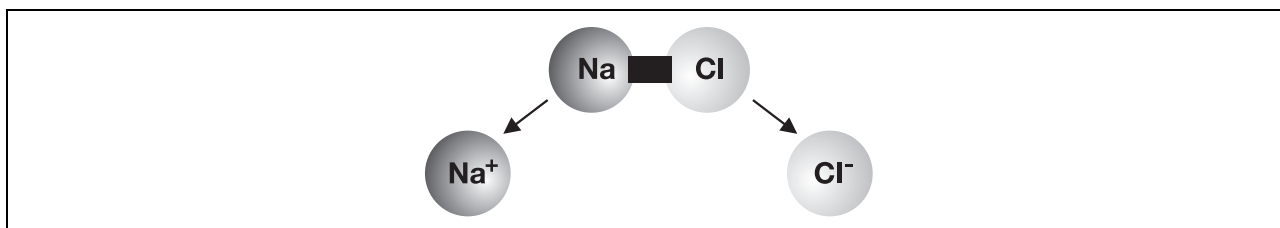

**Fig. 1:** Salts dissociate into positive and negatively charged ions

This relationship between the ion concentration and the ability to conduct the electric current makes the conductivity an interesting process variable in water analysis. It is especially suited for determining the concentration of dissolved salts.

The result of a conductivity measurement is not quoted in mg/liter or percent, but as a conductivity value in S/m (siemens per meter). In practice, the smaller units  $\mu\text{S}/\text{cm}$  and  $\text{mS}/\text{cm}$  are commonly used.

	S/m	S/cm	mS/cm	$\mu\text{S}/\text{cm}$
S/m	1	0.01	10	10,000
S/cm	100	1	1,000	1,000,000
mS/cm	0.1	0.001	1	1,000
$\mu\text{S}/\text{cm}$	0.000 1	0.000 001	0,001	1

**Table 1:** Conversion of conductivity units

The following table illustrates the relationship between the salt concentration and the conductivity.

Water or aqueous solution	Conductivity range at 25°C	Salt concentration
High-purity water	0.055 $\mu\text{S}/\text{cm}$	0 mg/l
Fully-desalinated water	0.055 to 2 $\mu\text{S}/\text{cm}$	0 to 1 mg/l
Rainwater	10 to 50 $\mu\text{S}/\text{cm}$	5 to 20 mg/l
Ground, surface and drinking water	50 to 1000 $\mu\text{S}/\text{cm}$	20 to 50 mg/l
Sea water	20 to 60 mS/cm	10 to 40 g/l
Saline solution	77 to 250 mS/cm	50 to 250 g/l

**Table 2:** Examples of conductivity values

<sup>1</sup> To be precise, this refers to the specific electrical conductance.

<sup>2</sup> The former symbols for electrical conductance were  $\kappa$  (kappa) or even  $\chi$  (chi).

Since 1993 the symbol used is  $\gamma$  (gamma), in accordance with European standardization.

# 1 Basics

## 1.2 Methods of measuring conductivity

### 1.2.1 General

The basic principle of conductivity measurement is the same with all methods: the instrument generates an electric voltage across the measured solution. An electric current flows whose value depends on the conductivity. Depending on the method or application, the instrument either maintains the voltage signal constant and records the change in electric current, or maintains the current value constant and evaluates the voltage change.

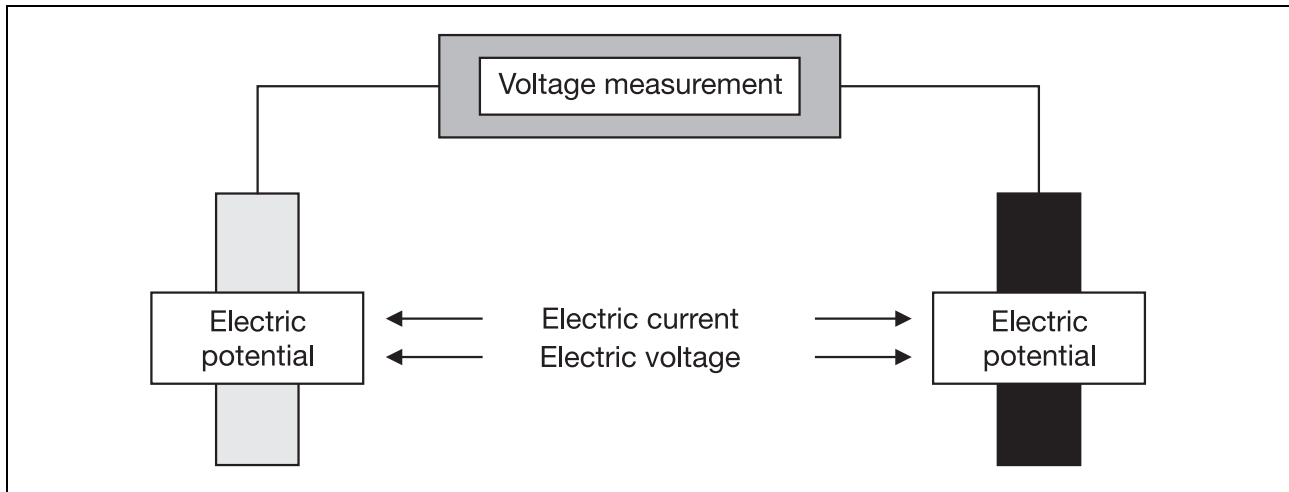

**Fig. 2:** Diagram of a conductivity measuring cell

Both measurement principles are based on Ohm's law:

$$R = \frac{U}{I} = \frac{1}{G} \quad (1)$$

R: electrical resistance

I: electrical current

U: electrical voltage, or rearranged for the conductance

G: conductivity

$$\gamma = \frac{I}{U} \cdot k' \quad (2)$$

$\gamma$ : (specific) electrical conductance

I: electrical current

U: electrical voltage

$k'$ : cell constant

At constant voltage, the current increases proportionally with the conductance. At constant current, the voltage decreases with increasing conductance. It is clear from Ohm's law that conductivity measurements really concern resistance measurements. The conductance value  $I/U$  is obtained from the reciprocal of the resistance.

### 1.2.2 The cell constant

Both the resistance and the conductivity depend on the dimensions of the electrical conductor. The length and surface area of the conductor determine the cell constant.

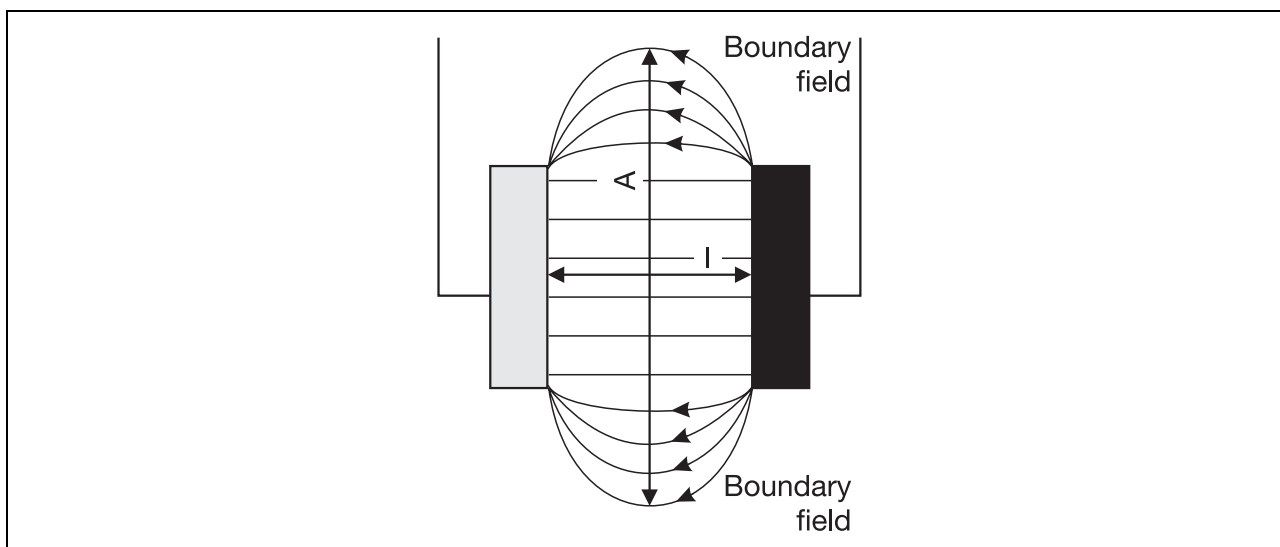

**Fig. 3:** Schematic representation of the active area

With a short length of conductor the electrodes are close together. The smaller the distance between the electrodes, the lower is the resistance of the measured solution. The influence of the electrodes on the ions increases.

A large conductor surface area is synonymous with large electrode surface areas. The bigger the surface area of the electrodes, the smaller is the resistance of the measured solution. As the surface area increases, more and more ions come within the range of influence of the electrodes.

The surface area of the electrical conductor is normally larger than the electrode surface area. The electrodes not only affect ions that are directly between the electrode surfaces, but also those in the boundary fields. The influence of the electrode boundary fields on the ions decreases with the distance. The boundary fields can be limited by the construction of the cell or the location, e. g. pipe internal diameters.

These influences are taken into account in the cell constant:

$$k' = \frac{l}{A} \quad (3)$$

$k'$ : cell constant

$l$ : length of the conductor

$A$ : surface area of the conductor

The (specific) electrical conductivity is therefore a substance-specific variable, which, in contrast to the conductance  $G$ , does not depend on geometric factors. The precise value of the cell constant is obtained from a calibration with a reference solution that has a known temperature-dependent conductivity.

# 1 Basics

## 1.2.3 AC voltage

The electric current between the electrodes depends on the movement of the ions in the measured solution. During measurement, the ions move towards the electrode that is oppositely charged at the time. Each ion that reaches one of the electrode surfaces balances out a part of the voltage between the electrodes. As it is no longer mobile, it blocks the current flow. This effect (polarization) can be counteracted by an AC voltage. Because of the constant reversal of polarity, only a small quantity of ions reach the electrodes, and then only for a short period. The more ions the solution contains, that is the higher the conductivity, the higher must be the frequency that the instrument uses to prevent polarization of the electrodes.

Modern instruments (e. g. JUMO dTRANS Lf 01) match the measurement frequency to the range in order to achieve optimal measurement results.

## 1.2.4 Measurement principles

- Conductive principle:  
2-electrode measuring cells,  
4-electrode measuring cells
- Inductive principle

### 2-electrode measuring cells

This is the simplest design for a conductivity measuring cell. The 2-electrode measuring cell is perfectly adequate for general industrial measurement. This cell consists of two electrodes and a housing that fixes the two electrodes. A constant AC voltage is applied between the two electrodes. The current flowing through the measured solution is the measurement signal.

With this type of cell, the cell constant and the nature of the electrode surface depend on the purpose the cell is to be used for.

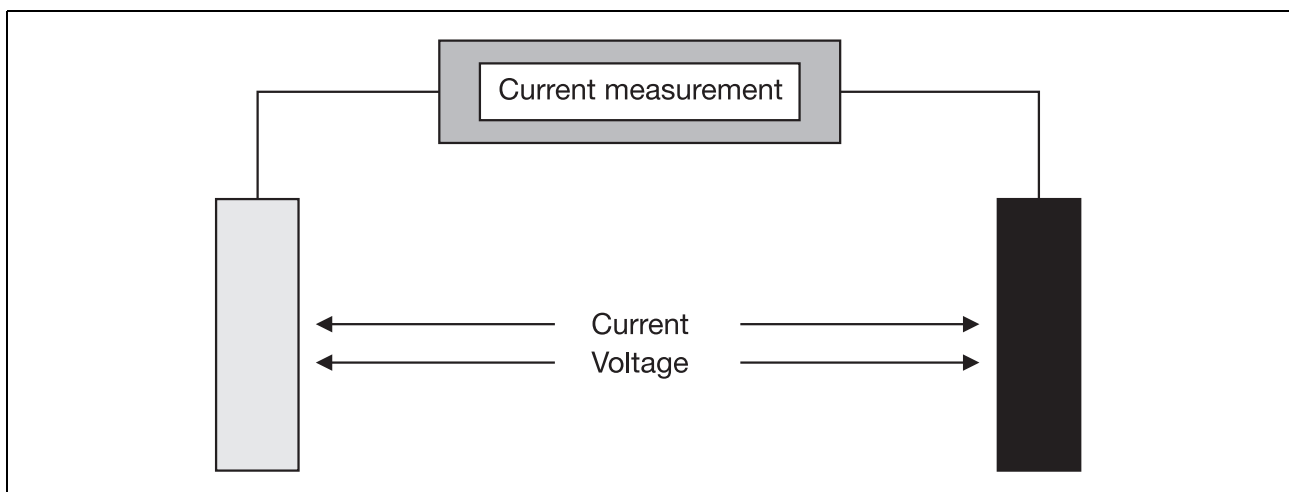

**Fig. 4:** Diagram of a 2-electrode measuring cell

A small cell constant means a large measurement signal. This effect is desirable for small conductivity values. At higher measured values it can overload the instrument. The optimal cell constant is thus all a question of the range.

Application examples	Conductivity range	Cell constant
Distillate, condensate, high-purity, fully-desalinated water	$\gamma < 10\mu\text{S/cm}$	$k' \leq 0.1\text{ cm}^{-1}$
Ground, surface and drinking water	$\gamma < 10 - 10,000\mu\text{S/cm}$	$k' \leq 1\text{ cm}^{-1}$
Sea water and saline solutions	$\gamma > 10\text{mS/cm}$	$k' \leq 10\text{ cm}^{-1}$

**Table 3:** Cell constants for various conductivity ranges with application examples

With measuring cells with a constant  $k' \leq 0.1\text{ cm}^{-1}$  the electrode surfaces are smooth, to improve the adjustment behavior at low conductivity values.

Measuring cells with a constant  $k' > 0.1$  have rough electrode surfaces to reduce the tendency to polarize at higher conductivity values.

#### 4-electrode measuring cells

The measuring cells contain two pairs of electrodes. One pair measures the current, the other measures the voltage applied across the measured solution.

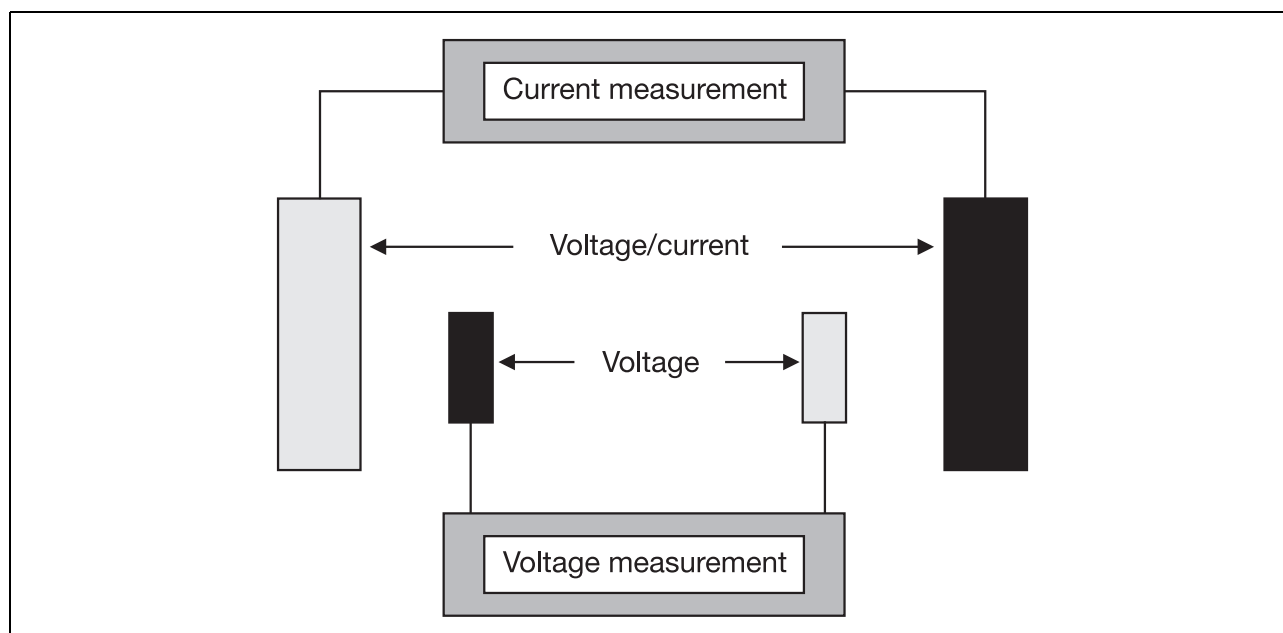

**Fig. 5:** Diagram of a 4-electrode measuring cell

The advantage of 4-electrode measuring cells is their insensitivity to interfering resistances due to long connecting cables, contaminants, or due to polarization, for example. These effects lead to low readings as they reduce the voltage that the electrodes apply to the measured solution. The second pair of electrodes determines the voltage across the measured solution. The instrument can take account of an interfering resistance by means of an electronic adjustment based on the measured current/voltage values of the two electrode pairs.

The conductivity meter calculates the conductivity value in accordance with the equation quoted earlier:

$$\gamma = \frac{I}{U} \cdot k' \quad (2)$$

# 1 Basics

An additional resistance, a layer of dirt, for example, always reduces the current and voltage in the same proportion. As the instrument measures both parameters, it can calculate the conductivity value, within its specification.

4-electrode measuring cells are used mainly in precision laboratory instruments.

## 1.2.5 Inductive measuring cell

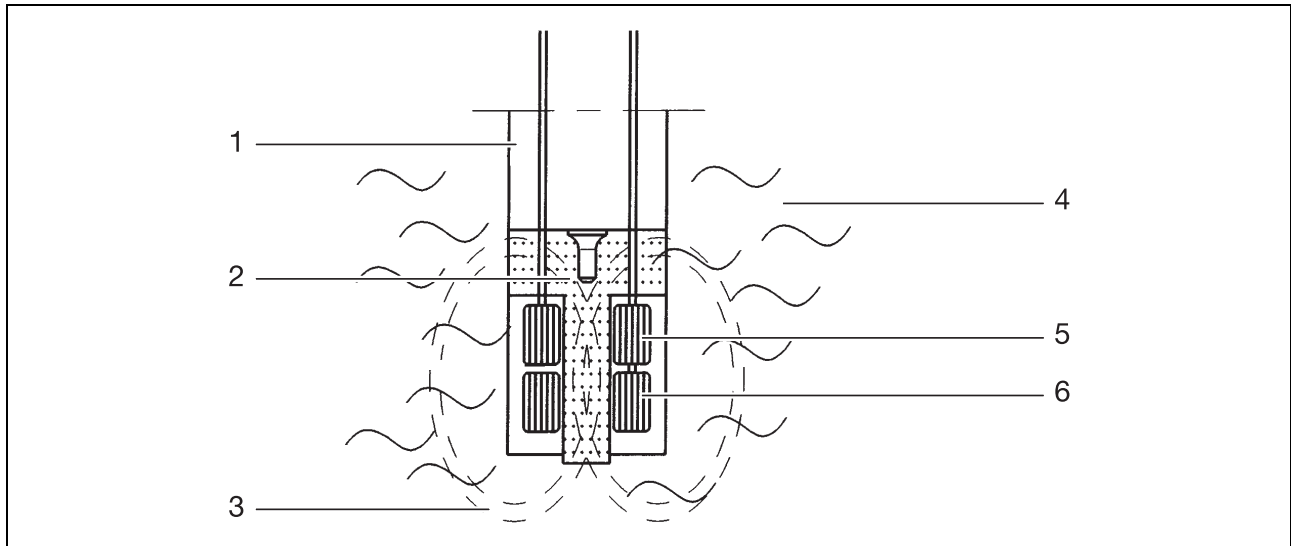

**Fig. 6:** Diagram of an inductive measuring cell

- |   |  |   |                   |
|---|--|---|-------------------|
| 1 | PVDF or PEEK body                          | 4 | Measured solution |
| 2 | T-shaped flow-through channel              | 5 | Receiver coil     |
| 3 | Liquid loop subjected to measuring current | 6 | Exciter coil      |

In this cell, the electrodes are replaced by two coils. One of the coils is the exciter coil. An AC current flows in this coil, producing a magnetic field in the vicinity of the coil. The measured solution is in the core of the coil. The current flow required for the measurement is induced in the measured solution by the magnetic field of the coil.

The current flowing in the measured solution produces its own magnetic field. This magnetic field induces an AC current in the second coil (receiver coil) with the appropriate voltage.

The voltage in the receiver coil is directly dependent on the current flowing in the measured medium, that is on the conductivity.

Because a magnetic field can even act through a plastic or teflon pipe, no direct contact between the coils and the measured medium is required. The advantages of this non-contact measurement technique are obvious. Measurement of aggressive media such as acids or alkalis can be made without any problems. High conductivities cannot cause polarization effects and consequent low readings.

The optimal conductivity meter depends on the particular application. Bench instruments are used in the laboratory, hand-held instruments on site, and transmitters for continuous process measurement.

Continuous measurement is essential for all applications where a full picture of the salt content of the water is required.

### 2.1 Arrangement of a process installation

The term measurement system includes the full set of instruments and equipment used for conductivity measurement, consisting of:

- conductivity sensor (measuring cell)
- immersion or flow-through fitting
- transmitter (instrument)
- connecting cable

#### 2.1.1 Measuring cells

2-electrode and 4-electrode measuring cells consist of a housing and the electrodes. The important considerations for a particular application are the cell constant and the nature of the electrode surfaces.

Conductivity:

$\gamma \leq 10\mu\text{S/cm}$ :	2-electrode cell $k \leq 0,1/\text{cm}$ , smooth electrode surfaces
$\gamma > 10\mu\text{S/cm}$ to $\leq 10\text{mS/cm}$ :	inductive, 2-electrode or 4-electrode cell $k \leq 1/\text{cm}$ , rough electrode surface
$\gamma > 10\text{mS/cm}$ :	inductive or 4-electrode cell $k > = 1/\text{cm}$ , rough electrodes



**Fig. 7:** 2-electrode cells with cell constant  $k = 0.01$  (top) and  $k = 0.1$  (bottom)

## 2 Measurement

### 2.1.2 Fittings

Fittings are used for holding and protecting the measuring cell. Immersion fittings permit measurements not only at the surface of the liquid but also deep inside it. A wide range of mounting elements and accessories permit mounting on almost all containers. The immersion fittings are normally manufactured from polypropylene (PP) and are supplied in immersion lengths up to 2000 mm. However, other materials (e.g. V4A) are also available for special purposes. Flow-through fittings permit measurement directly in the liquid flow lines or in the bypass of these lines.

It is essential that all fittings are situated in an easily accessible position, to permit regular servicing and inspection. It should be possible to change the sensor at any time without undue effort.

When mounting the sensor, it is important to ensure that the boundary field (see Chapter 1.2.2 „*The cell constant*“) is not interfered with. This means that a minimum clearance must always be maintained between the sensor and the bounding surface (pipe wall, container side, or the like).

### 2.1.3 Transmitter/controller

The transmitter has the job of conditioning the signal of the measuring cell. Here the signal from the measuring cell is converted to a standard signal (e. g. 4 – 20mA current signal) and can then be relayed to a downstream PLC or dosing unit. The indication and control of the conductivity then takes place here. If an on-site indication is required, suitable panel-mounting instruments must be installed. Appropriate surface-mounting enclosures or special instruments with cases suitable for site mounting can be supplied for local installation. Most of the instruments available nowadays are microprocessor instruments that can be individually adjusted to the particular measurement loop. This adjustment includes, on the one hand, the calibration of the cell constant, and, on the other hand, the calibration of the temperature coefficients (see Chapter 2.2.2 „*Calibration/adjustment*“).

Limit controllers are the type mainly used for conductivity control.



**Fig. 8:** JUMO dTRANS Lf 01 (transmitter/controller for 2-electrode measuring cells)



**Fig. 9:** JUMO AQUIS 500 CR (transmitter/controller for 2- and 4-electrode measuring cells)



**Fig. 10:** JUMO CTI-750 (inductive conductivity measurement system)

### 2.1.4 Instrumentation: cable material/connecting cable

Thanks to the modern, precise measurement technology of present-day transmitters, there are now only a few points to consider when selecting cable material, such as:

- A shielded control cable type should be used for the cable material.
- The cable should always be installed as a continuous run, i.e. terminal boxes, supplementary cable extensions or intermediate connectors must be avoided.
- Do not run the connecting cable parallel to cables supplying heavy electrical loads!

Suitable connecting cable:

e. g. JUMO Type 2990-9 (length specified) - 0

## 2.2 Commissioning the measurement system

### 2.2.1 Measurement location

The choice of an optimal measurement system is followed by the commissioning. This includes not only the installation of the measurement system but also the choice of the correct measurement location. The measurement system only indicates, at any time, the conductivity value that prevails at the point of measurement. Recommendations for selection of the measurement location are given in application-oriented standards and regulations, for example.

### 2.2.2 Calibration/adjustment

At the installation stage, it is sufficient to adjust the cell constant to the information given in the instructions for the measuring cell. Test resistors are available to check the correct operation of the transmitter. These resistors simulate a defined conductivity value. During the test the temperature coefficient must be set at 0 %/°C!

## 2 Measurement

### Calibrating the cell constant

Because of production tolerances, the cell constants of commercial grade cells are subject to deviations of up to  $\pm 10\%$ . At first glance, this may seem to be very inaccurate. In fact, an incorrectly adjusted temperature coefficient can result in considerably larger measurement errors.

Under normal circumstances, i. e. with higher conductivity ranges, the “inaccuracy” of the cell constant makes practically no difference. During commissioning or maintenance of a conductivity measurement system, and where there is a requirement for higher measurement accuracy, the commissioning engineer or service technician can adjust the combination of cell, cable and transmitter together. Modern transmitters (e. g. the JUMO dTRANS Lf 01) provide extensive options for doing this (e. g. automatic determination of the cell constant, calibration with reference solutions, etc.). The time interval between two calibrations depends on the operating conditions that the measuring cell is used in.

### The temperature coefficient ( $\alpha$ )

The conductivity of a solution is temperature-dependent; both the temperature and the temperature coefficient of the measured solution must therefore be known for a correct measurement. The temperature can either be measured automatically with a temperature probe (e. g. Pt 100 or Pt 1000) or it must be manually adjusted by the user. The temperature coefficient can be measured automatically by the conductivity transmitter, or it can be entered manually. Here too, the JUMO dTRANS Lf 01 provides suitable calibration routines.

T [°C]	Tk [%/°C]					
	0.00	0.50	1.00	1.50	2.00	2.50
0	0.0	-12.5	-25.0	-37.5	-50.0	-62.5
10	0.0	-7.5	-15.0	-22.5	-30.0	-37.5
20	0.0	-2.5	-5.0	-7.5	-10.0	-12.5
25	0.0	0.0	0.0	0.0	0.0	0.0
30	0.0	2.5	5.0	7.5	10.0	12.5
40	0.0	7.5	15.0	22.5	30.0	37.5
50	0.0	12.5	25.0	37.5	50.0	62.5
60	0.0	17.5	35.0	52.5	70.0	87.5
70	0.0	22.5	45.0	67.5	90.0	112.5
75	0.0	25.0	50.0	75.0	100.0	125.0
80	0.0	27.5	55.0	82.5	110.0	137.5
90	0.0	32.5	65.5	97.5	130.0	162.5
100	0.0	37.5	75.0	112.5	150.0	187.5

**Table 4:** Change in conductivity in % in relation to the actual temperature [°C] and the actual temperature coefficient [%/K], reference temperature 25°C

### Example

With an actual temperature of 75°C and a real temperature coefficient of 2%/°C the conductivity changes by 100%; i. e. it doubles in value!

### Result

An instrument without temperature compensation would indicate double the value when compared with an instrument with correctly adjusted temperature compensation.

### 2.2.3 Measurement conditions

The perfect measurement requires a knowledge of several important influencing variables.

#### Temperature/temperature coefficient/reference temperature

In addition to the salt concentration, the conductivity also depends on the temperature. As only the salt concentration is of interest, the instrument compensates for the effect of temperature. It converts the measured conductivity value to a reference temperature. This means that the instrument does not indicate the actual conductivity value of the measured solution, but instead indicates a value that the measured solution would have at the reference temperature. The indicated value remains the same when the temperature of the measured solution changes.

T [°C]	Tk [%/°C]						
	0.00	0.50	1.00	1.50	2.00	2.50	3.00
0	-50.0	-37.5	-25.0	-12.5	0.0	12.5	25.0
10	-30.0	-22.5	-15.0	-7.5	0.0	7.5	15.0
20	-10.0	-7.5	-5.0	-2.5	0.0	2.5	5.0
25	0.0	0.0	0.0	0.0	0.0	0.0	0.0
30	10.0	7.5	5.0	2.5	0.0	-2.5	-5.0
40	30.0	22.5	15.0	7.5	0.0	-7.5	-15.0
50	50.0	37.5	25.0	12.5	0.0	-12.5	-25.0
60	70.0	52.5	35.0	17.5	0.0	-17.5	-35.0
70	90.0	67.5	45.0	22.5	0.0	-22.5	-45.0
75	100.0	75.0	50.0	25.0	0.0	-25.0	-50.0
80	110.0	82.5	55.0	27.5	0.0	-27.5	-55.0
90	130.0	97.5	65.0	32.5	0.0	-32.5	-65.0
100	150.0	112.5	75.0	37.5	0.0	-37.5	-75.0

**Table 5: Indication error in % with incorrectly set temperature coefficient, temperature coefficient of the measured solution 2.0%/°C, reference temperature 25°C**

#### Example

With an actual temperature of 75°C and a temperature coefficient of 1%/°C set at the instrument, the indicated value is about 50% too high in relation to the actual value.

Depending on the application, the **reference temperature** is fixed at 25°C or 20°C, whereby the conductivity values related to T = 20°C are always lower than the values related to T = 25°C. For drinking water (temperature coefficient approx. 2.1%/°C) the difference between the indicated values is 10.5%.

## 2 Measurement

T [°C]	Tk [%/°C]						
	0.00	0.50	1.00	1.50	2.00	2.50	3.00
0	50	40	30	20	10	0	-10
10	30	25	20	15	10	5	0
20	10	10	10	10	10	10	10
25	0	2.5	5	7.5	10	12.5	15
30	-10	-5	0	5	10	15	20
40	-30	-20	-10	0	10	20	30
50	-50	-35	-20	-5	10	25	40
60	-70	-50	-30	-10	10	30	50
70	-90	-65	-40	-15	10	35	60
75	-100	-72.5	-45	-17.5	10	37.5	65
80	-110	-80	-50	-20	10	40	70
90	-130	-95	-60	-25	10	45	80
100	-150	-110	-70	-30	10	50	90

**Table 6:** Indication difference in % with different reference temperatures at the working and reference instruments, together with deviant setting of the temperature coefficient at the reference instrument, temperature coefficient at the working instrument 2.0%/°C, reference temperature at the working instrument 25°C, reference temperature at the reference instrument 20°C

### Example

With an actual temperature of 40°C and a temperature coefficient of 2.5%/°C set at the reference instrument, the working instrument indicates 20% more than the reference instrument.

Each measured solution shows an individual temperature behavior. With ground, surface and drinking water and communal wastewater, the conductivity increases by around 2.1%/°C related to the conductivity at T = 25°C.

The instrument incorporates a mathematical function, the temperature compensation function, for the temperature compensation, that is the conversion of the measured value to a value at the reference temperature. The temperature coefficient characterizes the temperature behavior of the measured solution, and must be set accordingly.

Measured solution	Temperature coefficient	Temperature range
Kaliumchlorid $C_{(KCl)} = 0.01 \text{ mol/l}$	$\alpha (25^\circ\text{C}) = 1.9 \text{ %/K}$	$\vartheta = 18 - 25^\circ\text{C}$
Phosphorsäure $C_{(H_3PO_4)} = 0.01 \text{ mol/l}$	$\alpha (25^\circ\text{C}) = 0.9 \text{ %/K}$	$\vartheta = 18 - 25^\circ\text{C}$
Salzsäure $C_{(HCl)} = 0.01 \text{ mol/l}$	$\alpha (25^\circ\text{C}) = 1.4 \text{ %/K}$	$\vartheta = 18 - 25^\circ\text{C}$

**Table 7:** Examples of temperature coefficients

The efficiency of the temperature compensation is easily checked:

- Bring the measured solution to the reference temperature ( $\pm 1^\circ\text{C}$ ).
- Measure and record the conductivity.
- Heat/cool the measured solution by approx. 10°C. There must be no loss of substance here due to chemical reactions, precipitations or gassing.

- The difference between the new value and the value at the reference temperature corresponds to the deviation as a result of the temperature compensation. If necessary, adjust the temperature coefficient to the behavior of the measured solution. .

### Dirt and deposits

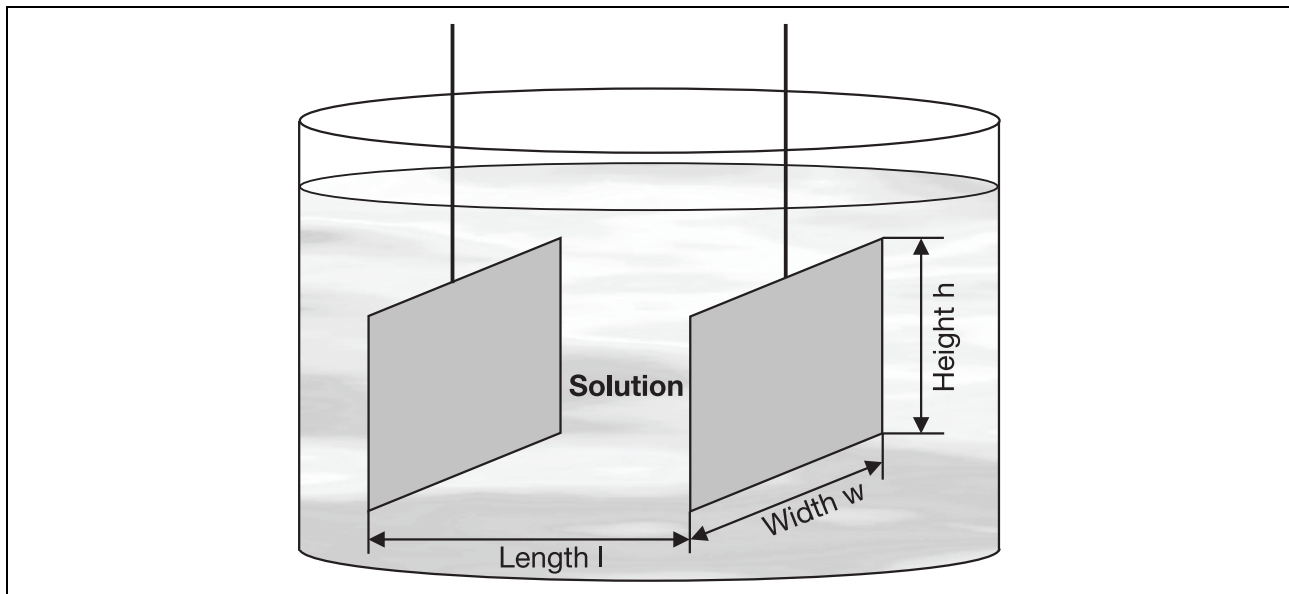

**Fig. 11: Actual electrodes in a measured solution**

Dirt on the electrodes causes the measured value to be too low, as a result of the reduction in surface area of the electrode. With a 2-electrode cell, the instrument only receives the current signal. It uses the terminal voltage applied to the electrodes of the measuring cell for the voltage value. Where there is a deposit on the electrodes, the instrument only receives the reduced current signal and calculates too low a value for the conductivity.

Before a measurement, it must be ensured that the measuring cell is in perfect condition. The condition can be determined with a reference solution:

- Set the temperature coefficient at the transmitter to 0%/°C.
- Bring the reference solution to the reference temperature  $\pm 1^\circ\text{C}$  (20°C or 25°C).
- Flush the measuring cell with some reference solution.
- Measure the conductivity of the reference solution and compare with the nominal value of the reference solution.

Potassium chloride concentration	Conductivity at 20°C	Conductivity at 25 °C
$C_{(\text{KCl})} = 0.01 \text{ mol/l}$	1278 $\mu\text{S/cm}$	1413 $\mu\text{S/cm}$
$C_{(\text{KCl})} = 0.1 \text{ mol/l}$	12.2 mS/cm	12.9 mS/cm
$C_{(\text{KCl})} = 3 \text{ mol/l}$	275 mS/cm	298 mS/cm

**Table 8: Conductivities of some typical reference solutions**

- Clean the electrodes of the measuring cell if the deviation is too large.

## 2 Measurement

---

### Polarization

The measurement is made with an AC voltage. The instrument increases the frequency with increasing conductivity. However, with 2-electrode measuring cells, there is always a maximum conductivity above which the polarization cannot be completely eliminated, with the result that the readings obtained are clearly low.

These low readings do not occur with inductive or 4-electrode measuring cells.

### 2.2.4 Reference solutions

Reference solutions are used as a means of calibrating the measurement system. They are aqueous solutions of potassium chloride with known conductivity values. Reference solutions are categorized into primary reference solutions, secondary reference solutions and working reference solutions, according to their properties.

Primary reference solutions show the lowest uncertainty in conductivity value ( $U(\gamma) = 0.03\%$ ). They are mainly used in metrological institutes.

Secondary reference buffer solutions have the same composition as primary solutions. The uncertainty of the conductivity value is around  $U(\gamma) = 0.12\%$ .

Working reference solutions are solutions for practical use; their uncertainty depends on the manufacturer, although they should be within the range  $U(\gamma) \pm 0.4\%$  to  $U(\gamma) \pm 1\%$ . Working reference solutions are best suited for calibration of installed and hand-held measurement systems.

There are reference solutions for the range from around  $100\mu\text{S}/\text{cm}$  up to  $10\text{mS}/\text{cm}$ . Recommendations are available for making up suitable solutions for higher conductivity values.

It is sufficient to test one of the solutions in the upper part of the permissible range. Disturbing influences such as polarization or dirt have the most pronounced effect here.

Reference is often made to the traceability of the reference solution. The traceability concerns its conductivity value. It means that the conductivity value was tested by the manufacturer either directly against a primary reference solution, or via an intermediate solution (e. g. a secondary reference solution).

### Example

working reference solution	→	secondary reference solution	→	primary reference solution	
or		→	working reference solution	→	primary reference solution

The traceability of the conductivity value forms a basis for calculating the uncertainty.

Formerly, the idea of quality assurance related mainly to the manufacture of products such as hi-fi equipment, instrumentation or cheese. Analysis was just a means of proving the quality. Within the framework of Good Laboratory Practice (GLP) and certification procedures (e. g. in accordance with ISO 9000) laboratories have had to pay greater attention to the issues of the quality of measurement procedures and values, in the context of standard operating procedures (SOPs). This is an ongoing process, so that nowadays regulations concerning quality assurance must also be complied with in process measurement. Examples of this in Germany include the specifications issued by the Regional Water Authorities (LAWA), the Directive ENV ISO 13530 embodied in the unified methods for testing water and wastewater, or the specification of the Wastewater Organization (ATV-DVWK M 704).

### How accurate is a conductivity measurement?

It is almost impossible to answer a question on the accuracy of measurements. A statement of the accuracy presupposes that the true value is known, which is not the case in practice. The uncertainty of a measurement can be estimated. However, the term “estimate” should not be associated with the term “approximate”, but rather with an informed assessment.

The statement that the uncertainty  $U(\gamma)$  is  $\pm 5\%$  means that there is a 95% probability that the true conductivity value of the measured solution will not deviate by more than  $\Delta\gamma \pm 25\mu\text{S}/\text{cm}$  from a measured value  $\gamma = 500\mu\text{S}/\text{cm}$ . If the value for the uncertainty is halved, the probability is now only 67%.

A knowledge of the uncertainty can be of special significance for operational measurement in installations. The important thing here is, for example, when a limit is exceeded.

### Example

A limit of  $\gamma = 1000\mu\text{S}/\text{cm}$  is specified for the conductivity and the measured value is  $\gamma = 970\mu\text{S}/\text{cm}$ , with an uncertainty of  $U(\gamma) \pm 6\%$ . Although the measured value  $\gamma = 970\mu\text{S}/\text{cm}$  is still below the limit, there is a risk that the limit is being infringed. Only when the measured value is less than  $\gamma = 940\mu\text{S}/\text{cm}$  can an infringement of the limit be almost (but not completely) ruled out.

Quality assurance measures make a fundamental contribution towards reducing the uncertainty.

## 3.1 Documentation

A fundamental component of quality assurance is the documentation of all information relevant to the measurement. The records serve as proof of the condition of the measurement system and, of course, the measured product. Measurements collected over a longer period of time are a good basis upon which to make decisions, for example:

- on maintenance of the measurement system
- on control of the water parameters
- on troubleshooting in the event of a fault
- or for the acquisition of new measurement systems.

An essential requirement for these and other options is the complete documentation of the measured values and the conditions under which the values were obtained. This includes the measurement conditions, dates of the calibrations, together with information on the measurement system used.

The documentation must be complete, and arranged so as to be easy to read and understand, so that the facts of a matter can be cleared up even after long periods of time.

The measured values are normally already recorded by the transmitter.

## 3 Quality assurance

---

### General information

A log should contain all data about the measurement point, the measurement system and any service work that may have been carried out:

- designation and location of the measurement point
- full address of a contact person
- serial numbers of the components of the measurement system
- purchase date and commissioning date of the measurement system
- date and reason for repair work
- name and address of the service provider for service and repair measures.

### Kalibrierdaten

A calibration record should include the following data:

- designation and location of the measurement point
- serial numbers of the components of the measurement system
- name of the responsible person
- designation, serial number and use-by date of the reference solution used
- date and data of the calibration  
(e. g. measured value, temperature value, nominal value of the reference solution)

### Measured values

In addition, records of the measured values should also contain the date and time and any relevant accompanying parameters, e.g. statement of the temperature.

### Other information

To complete the documentation, descriptions of the measurement methods used, including the descriptions of the calibrations, adjustment procedures and instructions on maintenance and storage of the measurement system must be available. In addition, all operating instructions and other specifications and instructions must be filed in the documentation folder.

### 3.2 Maintenance

A measurement system, and especially measuring cells, age according to the measurement conditions. Wear and contaminants restrict its reliability and cause deviations. Regular examinations help to detect unreliable components and to restore them to perfect condition by cleaning, for example.

A fault in the measurement function that occurs in the interval between calibrations can only be detected by means of the recorded values.

A fault can show itself through scattered values or by measured values that deviate from the usual previous empirical values. The decision on whether this is a normal event or whether an intervention is required must be made on the basis of the documented data.

#### Scattered measured values

Scattered measured values alone are not yet an indication of a fault. The scattering is mostly caused by normal changes in the water or the measured solution, or in the measurement procedure.

One reason why a measurement system can cause scattered values is, for example, an incorrectly set temperature compensation. The instrument now reacts to temperature changes with scattered measured values.

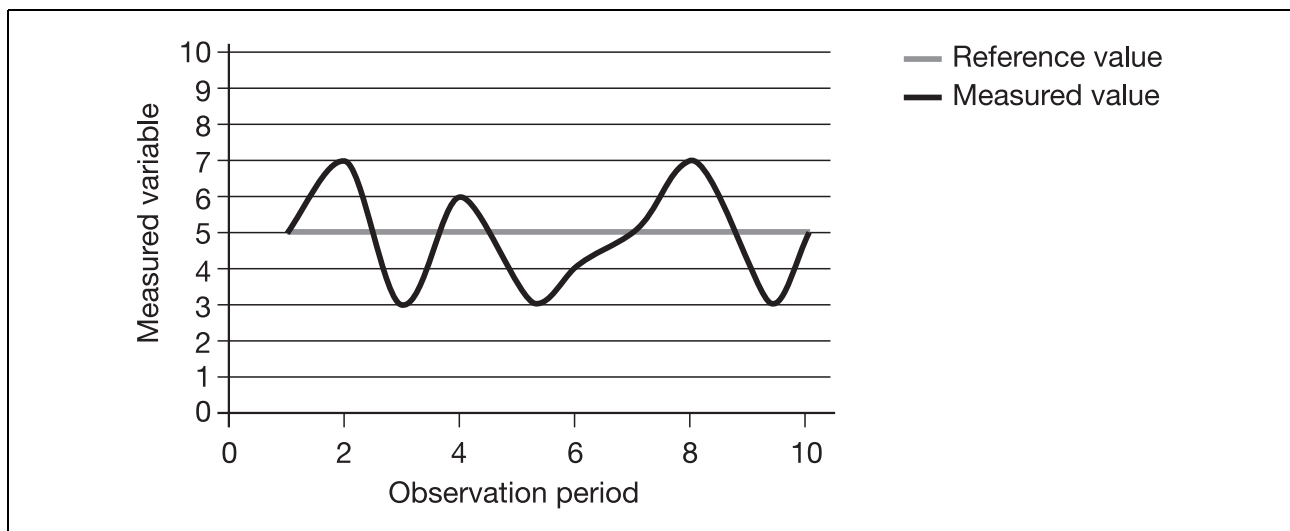
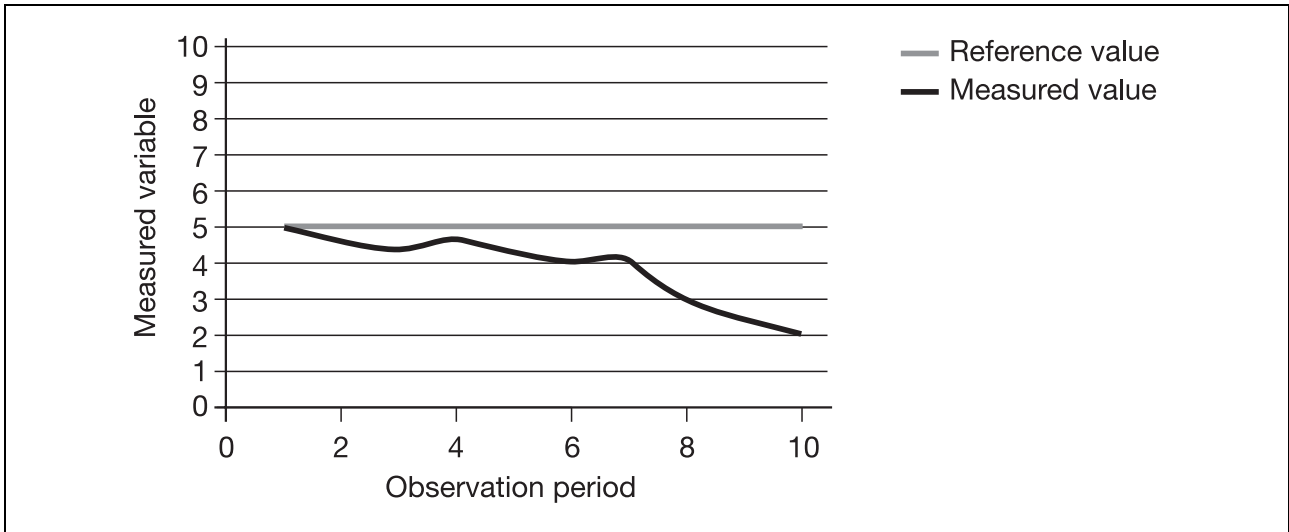

**Fig. 12:** The measured values are scattered irregularly about the nominal value

# 3 Quality assurance

## Drifting measured values

“Drifting” describes the phenomenon of permanently increasing or decreasing values.

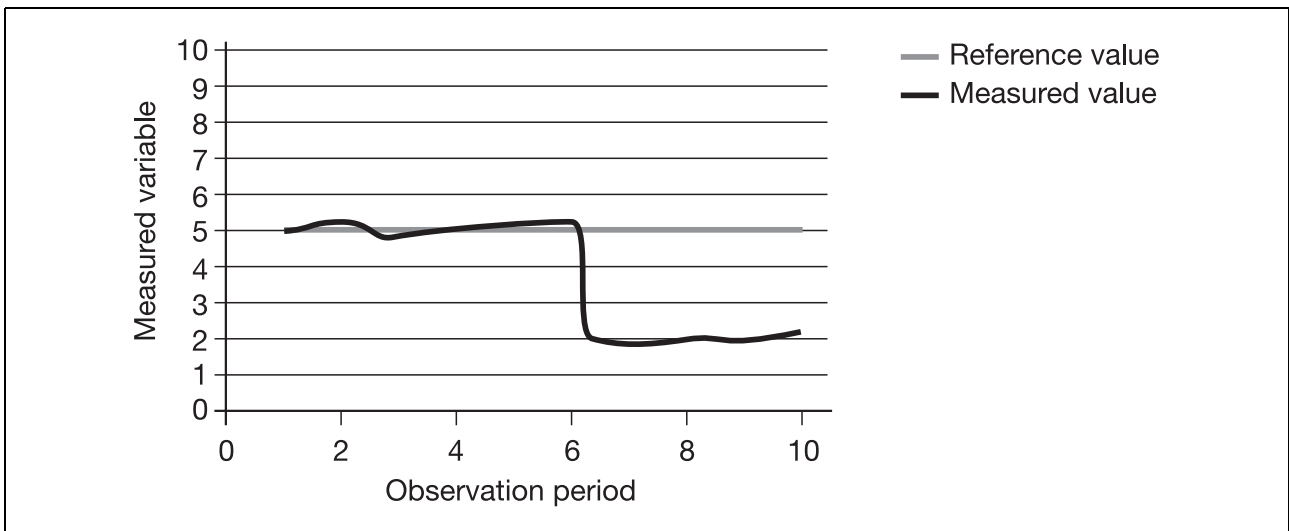

**Fig. 13: The deviation between the measured value and nominal value increases with time**

Increasing values are not connected with the measurement system. The cause of decreasing values can be attributed to a contamination of a 2-electrode measuring cell with a conductivity above 100µS/cm. Dirt deposits increase the resistance at the electrodes, so that the current decreases.

## Sudden deviations

If a significant change in value occurs within a few minutes, the likely cause is an electrical fault. However, it could also simply be that the measuring cell is no longer immersed in the water.



**Fig. 14: A significant deviation from the nominal value occurs within a few minutes**

### 3.3 Problems/actions

Problem	Possible cause	Action
No indication, or unchanging output	No supply	Check supply, check terminals
Indicated value „000“ or unchanging output „0 %“	Sensor not immersed in the medium, level in container too low	Fill container
	Flow-through fitting clogged	Clean flow-through fitting
	Faulty sensor	Check sensor
	Faulty probe cable	Check probe cable
Incorrect or fluctuating indication	Sensor not immersed deeply enough	Fill container or flow-through fitting
	No intermixture	Ensure good intermixture, make sure that there is approx. 5 mm free circulation space on all sides of sensor
	Air pockets	Check installation location
	Electrical interference	Check supply for unacceptable interference level (e. g. poor isolation from frequency converters), check probe cable material (use shielded cables), check cable routing (not to be run parallel to cables supplying heavy electrical loads)
	Deposits on the measurement surfaces	Clean measuring cell, see Chapter 3.4 „Cleaning“
	Temperature coefficient incorrect	Determine temperature coefficient correctly, see Chapter 2.2.2 „Calibration/adjustment“
	Working and reference instruments have different temperature coefficients	see Chapter 2.2.3 „Measurement conditions“
	Working and reference instruments have different reference temperature	see Chapter 2.2.3 „Measurement conditions“
	Polarization	Use inductive measurement principle at high conductivities (above approx. 10 mS/cm), see Chapter 1.2.4 „Measurement principles“ or see Chapter 2.1.1 „Measuring cells“

**Table 9: Trouble-shooting**

### 3.4 Cleaning

If too high a deviation occurs during testing in the reference solution, the only effective measure to clear the fault is to clean or exchange the measuring cell. The cleaning agent used basically depends on the nature of the contamination. In most cases, warm water with some household washing-up liquid is sufficient to remove greasy or oily deposits. Lime or iron oxide deposits can be removed with vinegar, citric acid or dilute hydrochloric acid.

#### Note

Never mechanically clean measuring cells with platinized platinum electrodes. Any mechanical contact damages the platinized surface and this can only be remedied by a new platinization.

## 3 Quality assurance

---

### 3.5 On-site test options

Manufacturers of measurement and control equipment are repeatedly asked about the reliability of continuous measurement. For high-purity water in particular, comparison measurements are often only feasible through laboratory analysis. The following on-site options are available for the plant operator:

#### Testing the transmitter

The transmitter can be checked by using precision resistors.

However, it should be assumed here that the transmitter will not have lost its accuracy (as adjusted) under normal circumstances.

#### New determination of the cell constant

As the measuring cell is exposed to the measured medium and its constituents, it makes sense to check the cell at regular intervals (determination of the cell constant).

#### Test intervals

The interval between testing intervals is laid down by the plant operator or else is dictated by legal requirements. During this procedure, the transmitter is adjusted to match the new (altered) cell constant.

#### Comparison measurement

A comparison measurement with a reference instrument can be used to make a fresh determination of the cell constant of the high-purity water measuring cell. In this case, care must be taken that the temperature compensation on both instruments (JUMO instrument and reference instrument) is switched off, i. e. set at 0%/°C. This ensures that the actual value present in the conductivity cell is displayed, thus avoiding possible differences in indicated value caused by the temperature compensations of the two instruments working differently.

#### Factory measurement

If the end user does not have the appropriate measurement and test equipment available, then the cell constant can also be freshly determined by the manufacturer (e.g. JUMO).

For such situations, it may be a good idea to have a second calibrated conductivity cell on site to avoid down-times.

### 3.6 Storage of the measuring cell

Conductivity cells can be stored dry without any problems and have a good shelf-life.

#### Note

Deposits caused by dust, residues from evaporated water of condensation, surface changes due to aggressive atmospheres and other factors change the cell constant (see Chapter 3.3 „Problems/actions“).

Always store measuring cells with platinized platinum electrodes in deionized water. Drying out damages the platinized surface and this can only be remedied by a new platinization.

Conductivity measurements are important in many areas of technology and environmental protection. Depending on the application, the measurement can take place in the laboratory, on site with a hand-held instrument, or continuously, in a process environment, for example.

The following practical applications should be considered in more detail. Conductivity measurement in:

- wastewater treatment plants,
- galvanizing plants,
- beverage bottling plants,
- pharmaceutical production,
- power stations,
- desalination plants.

### 4.1 Wastewater treatment plants

The conductivity of domestic wastewater is somewhat higher than that of the drinking water used in the area. The higher the conductivity value of the drinking water, the less is the relative increase in the conductivity values of the wastewater. Conductivity measurement systems are only present in communal wastewater treatment plants if a much larger increase in conductivity is expected as a result of industrial discharges. Conductivity measurement systems are encountered more frequently in industrial plants, as the following examples will show.

The measurement system used depends on the nature of the contamination, the temperature, or even on chemical corrosion.

Where contamination is concerned, 4-electrode cells (measurements in basins and channels) or inductive measuring cells (measurements in pipelines or with aggressive wastewaters) are the optimal methods.

With wastewaters that are carrying significant quantities of chemicals and/or show large temperature variations, the transmitter must provide an adequate adjustment range for the temperature coefficients.

## 4 Applications

---

### 4.2 Galvanizing plants

The water for the rinsing baths flows in a closed cycle. An ion exchanger desalinates it before it passes back into the rinsing baths. The ionogenic constituents of the rinsing water block the ion exchanger resins. These substances collect in concentrated form during the regeneration, although in smaller liquid quantities.

The ion exchanger does not react to the volume of the water, but to its salt burden. Because the total salt content in the wastewater at least doubles due to the regeneration of the resins, the total salt charge is minimized. This can be achieved by column washes or slow flowing pre-washes.

The concentration of an individual column wash should, on average, not exceed 10% of the preceding process water, so a pre-wash cascade is most advantageous.

For most purposes, the clean water should have a conductivity of less than 30 $\mu$ S/cm. A standard measurement system is adequate for this application.

### 4.3 Beverage bottling plants

Bottling plants, whether for beer, lemonade, milk or wine, impose particularly demanding requirements with regard to hygiene. This applies to both consumer protection and the shelf-life of the beverage.

After a bottling process, the tanks and pipelines are thoroughly cleaned. It is important that the subsequent rinsing process completely removes the cleaning agent. If the rinsing process is too long, firstly, the costs for supply of fresh water increase, and, secondly, the volume of wastewater is increased unnecessarily.

The conductivity measurement offers the option of both checking the concentration of the cleaning agent and, at the same time, determining the precise moment in time for its subsequent removal.

The measuring cell must be able to withstand the sometimes very hot and corrosive cleaning agent, and must also be suitable for the very high conductivity values that occur from time to time. Inductive measurement technology is ideal for this application, as the measurement system itself has no contact with the measured solution.

The transmitter itself must be capable of variable settings to match the temperature behavior of the measured solution, as the temperature and the temperature behavior of the rinsing solutions can vary greatly between the rinse processes.

## 4.4 Power stations

### General

Water for use in power stations must be particularly pure. This water has the disadvantage that it is very aggressive and can cause considerable corrosion damage.

Because of this, the water is not suitable for use in power stations until it has passed through a number of pretreatment stages.

### Boiler feed water

Boiler water is used for steam generation. Dissolved impurities are left behind during the evaporation process, so that their concentration increases over time. At too high levels of concentration, dangerous surface layers (scale) build up on the boiler walls. The thermal insulation of the surface layer can easily reduce the boiler efficiency by more than 10%. Boiler explosions have occurred in the past due to damage to the surface coating linked to local overheating of the water. So the supply of boiler feed water serves not only to replace the evaporated boiler water, but also it must lower the concentration of the impurities at the same time. The boiler feed water itself must be as free from dissolved substances as possible; the only presence permitted is an alkalizing agent, such as ammonia.

The limit for the water impurities can be calculated from the conductivity value using the Langlier index. For boiler feed water, the value specified is  $g(25^{\circ}\text{C}) = 0.2\ \mu\text{S}/\text{cm}$ .

### Condensate

The water collected by condensing the steam has such a high purity that it can be reused directly to feed the boiler. It is almost like distilled water.

Nevertheless, impurities can pass into the condensate due to a leak in the condenser cooling system. However, even slight leakages can be detected by a comparison of the conductivity values upstream and downstream of the cooling system.

### Cooling water

Here too, a high purity level of the circulating water in the cooling circuit is required, to protect the turbines from corrosion damage. A high level of protection against corrosion damage can be achieved by having three conductivity measurement points arranged in the system. An emergency shutdown occurs if the limit is exceeded at two out of the three measurement points.

### Measurement

Pure water imposes considerable demands on the measurement technology used. Even the slightest impurities from the air or from the material of the measurement system can markedly increase the conductivity. That is why the conductivity measurement takes place in the actual flow. The material of the measuring cell and the flow-through container must not themselves influence the conductivity, as is the case, for example, when glass is used. Measuring cells and containers made from stainless steel have proved themselves as the best choice for this application.

High-purity water has a very low conductivity value. A cell constant of  $k' = 0.1\ \text{cm}^{-1}$ , or even better  $k' = 0.01\ \text{cm}^{-1}$ , is an essential requirement for an adequate measurement signal of the measuring cell. A further measure for amplification of the measurement signal is the provision of a strong acid ion exchanger upstream of the measuring cell. It amplifies the signal by a factor of 3 to 4, because the contained cations are replaced by hydrogen ions with a higher equivalent conductivity. Furthermore, the exchanger eliminates the disturbing influence of the alkalizing agent.

An important property of the transmitter is the temperature compensation.

In the condenser, the temperature upstream of the cooler is noticeably higher than downstream. To be able to detect even small differences in conductivity, the transmitter must reliably compensate the two values to the reference temperature.

## 4 Applications

In a cooling system the temperatures can be different because of the spatial separation of the measurement points. A meaningful comparison of the measured values is only feasible with a reliable temperature compensation.

The temperature behavior at these very low conductivities depends on two factors, which are:

- the intrinsic conductivity of the water
- and the conductivity of the dissolved substances.

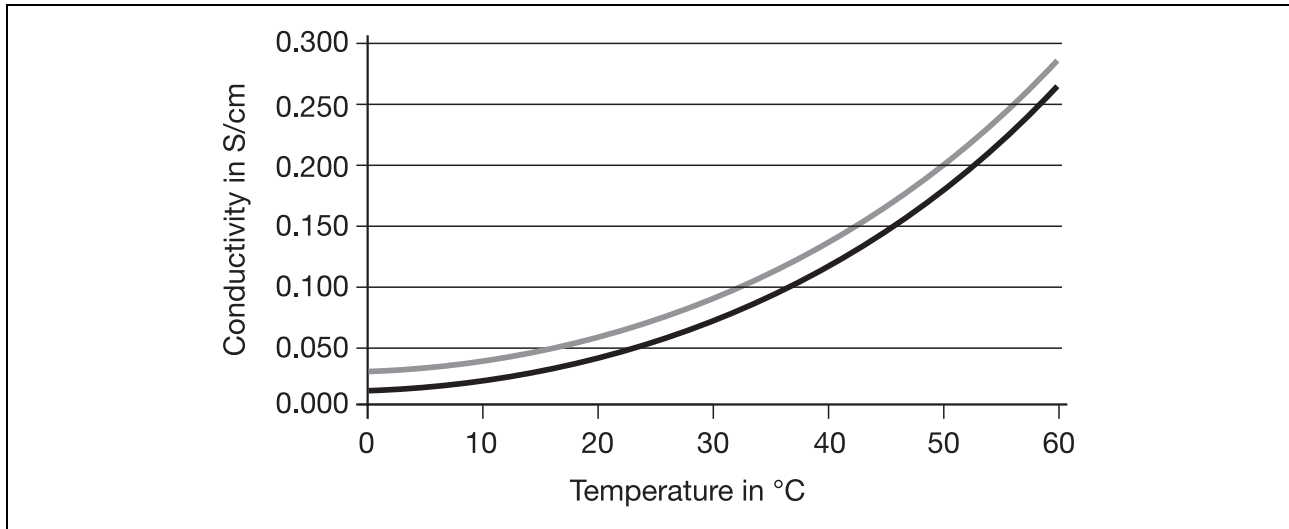

**Fig. 15:** Overall conductivity of the water (pale line), intrinsic conductivity of the water (black line)

The temperature behavior of the intrinsic conductivity of the water is mainly the result of dissociation of the water molecules and the viscosity of the water. This behavior is very strongly defined.

Downstream of the ion exchanger, the dissolved substances are mainly a matter of hydrogen ions with corresponding opposed ions. On the one hand, these ions exhibit an individual temperature behavior, and on the other hand they directly influence the dissociation behavior of the water. The higher the proportion of the hydrogen ions, the lower is the intrinsic conductivity of the water. Even with a conductivity above 1  $\mu\text{S}/\text{cm}$ , the only thing that determines the temperature behavior of the water is the hydrogen ions.

Modern transmitters for conductivity measurement in high-purity water automatically take account of these relationships in the temperature compensation<sup>3</sup>.

<sup>3</sup> Supplementary information is provided in technical article FAS614 „Information on high-purity water measurement“.

## 4.5 Pharmaceuticals

The pharmaceutical industry uses water that has to meet the requirements of USP (water conductivity <645>). The decision on whether a particular water is suitable or not depends on the conductivity and the pH value.

### Measurement

The conductivity measurement takes place uncompensated. In this instance, the measured values may not exceed the limits in the following table:

Temperature in °C	Conductivity in µS/cm	Temperature in °C	Conductivity in µS/cm
0	0.6	55	2.1
5	0.8	60	2.2
10	0.9	65	2.4
15	1.0	70	2.5
20	1.1	75	2.7
25	1.3	80	2.7
30	1.4	85	2.7
35	1.5	90	2.7
40	1.7	95	2.9
45	1.8	100	3.1
50	1.9	-	-

**Table 10: USP limits as per Chap. water conductivity <645>, Stage 1**

### Carbonic acid test (Stage 2)

Even if the value is higher than these limits, there are two further test procedures where, if a positive result is obtained, the water can still be used.

The water sample is strongly stirred at a temperature of  $\vartheta = 25 \pm 1^\circ\text{C}$ . If the conductivity value is below  $2.1 \mu\text{S/cm}$ , then the water is suitable for use in production. If the value is higher than this, a pH test must be carried out to decide whether the water is usable.

### pH test

To stabilize the pH measurement, 0.3ml of saturated potassium chloride solution is added per 100ml of the water sample. The temperature must remain constant at  $25^\circ\text{C} \pm 1^\circ\text{C}$  during the measurement. The pH value measured must now lie between 5.0 and 7.0. Furthermore, the conductivity of the measured solution must not exceed the values in the following table.

## 4 Applications

---

pH	Conductivity in $\mu\text{S}/\text{cm}$	pH	Conductivity in $\mu\text{S}/\text{cm}$
5.0	4.7	6.1	2.4
5.1	4.1	6.2	2.5
5.2	3.6	6.3	2.4
5.3	3.3	6.4	2.3
5.4	3,0	6.5	2.2
5.5	2.8	6.6	2.1
5.6	2.6	6.7	2.6
5.7	2.5	6.8	3.1
5.8	2.4	6.9	3.8
5.9	2.4	7.0	4.6
6.0	2.4		

**Table 11: USP limits as per Chap. water conductivity <645>, Stage 3**

If a measurement system is to be used in the pharmaceutical industry, the manufacturer must supply a calibration certificate. The instrument must have a minimum resolution of  $0.1 \mu\text{S}/\text{cm}$ . The uncertainty of the instrument (without the uncertainty of the cell) must not exceed  $U(\gamma) \pm 0.1 \mu\text{S}/\text{cm}$ . The maximum uncertainty applicable to the measuring cell is  $U(\gamma) \pm 2\%$ .

### 4.6 Full desalination plants

Deionized water is one of the things taken for granted in analytical laboratories and in many areas of industry.

The water is formed mainly in ion-exchange plants, but also in reverse osmosis and distillation plants.

The conductivity must be matched to the intended use. Various “laboratory water qualities” are defined, for example, in ISO 3696 (“Water for analytical purposes”), or in ASTM D 1193-99e1 (“Standard specification for reagent water”).

Ion exchangers in particular have only a limited capacity. If this is exceeded, sodium and chloride ions can begin to break through the barrier presented by the exchanger. The conductivity of the water increases, indicating that the exchanger materials are exhausted.

Continuous monitoring prevents the water quality falling to a level where it is unusable. The measuring cell and the flow-through container must be made of steel. Materials such as glass cause high readings due to the release of ionic constituents.

Temperature compensation is significant in the transmitter.

The temperature behavior at very low conductivities depends on two factors, which are:

- the intrinsic conductivity of the water
- and the conductivity of the dissolved substances.

Once the exchanger materials are exhausted, sodium and chloride ions begin to penetrate the exchanger. These ions exhibit a characteristic temperature behavior. Modern transmitters for conductivity measurement in high-purity water automatically take account of these relationships in the temperature compensation.

## 4.7 Concentration measurements

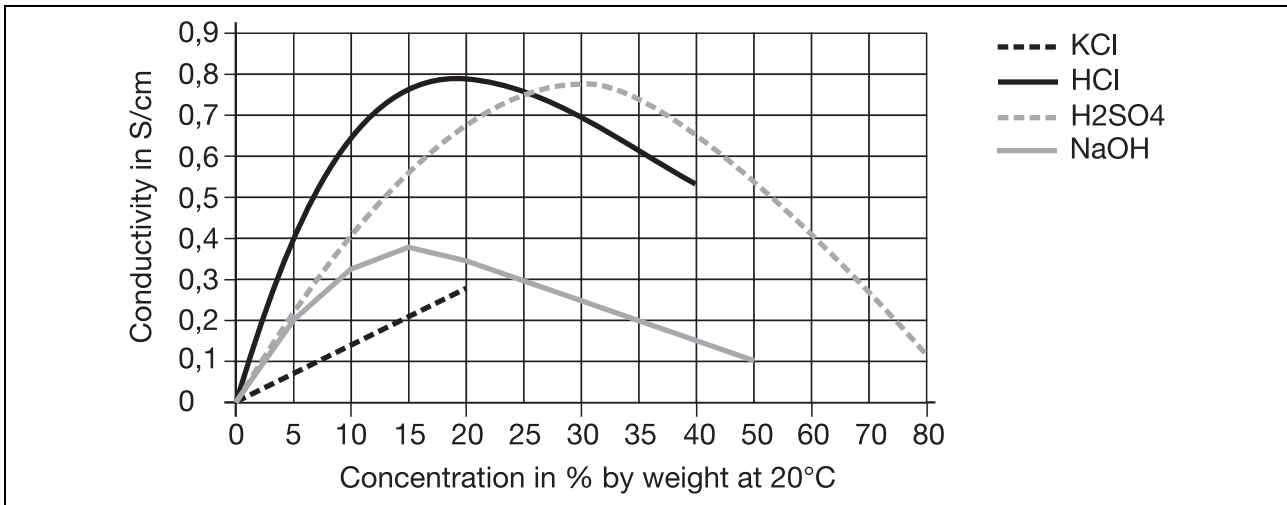

**Fig. 16: Relationship between conductivity and concentration (for various substances)**

A conductivity measurement does not give any information on the nature of the dissolved substances. The measured value could have been produced by any ions. For solutions with a varying or unknown composition, the measured conductivity is a substitute for a concentration value.

It is different for solutions with a known composition. In this case, the conductivity measurement can provide very precise concentration values. The conductivity value can be directly converted to the corresponding concentration value, either on the basis of a table of values or a calibration function.

In some applications (e.g. topping up of acids and alkalis), it is customary to display the concentration value instead of the conductivity value.

The relationship between concentration and conductivity of acids and alkalis is not linear over wide ranges, and so can only be reproduced to the required level of accuracy by using microprocessor controlled instruments.

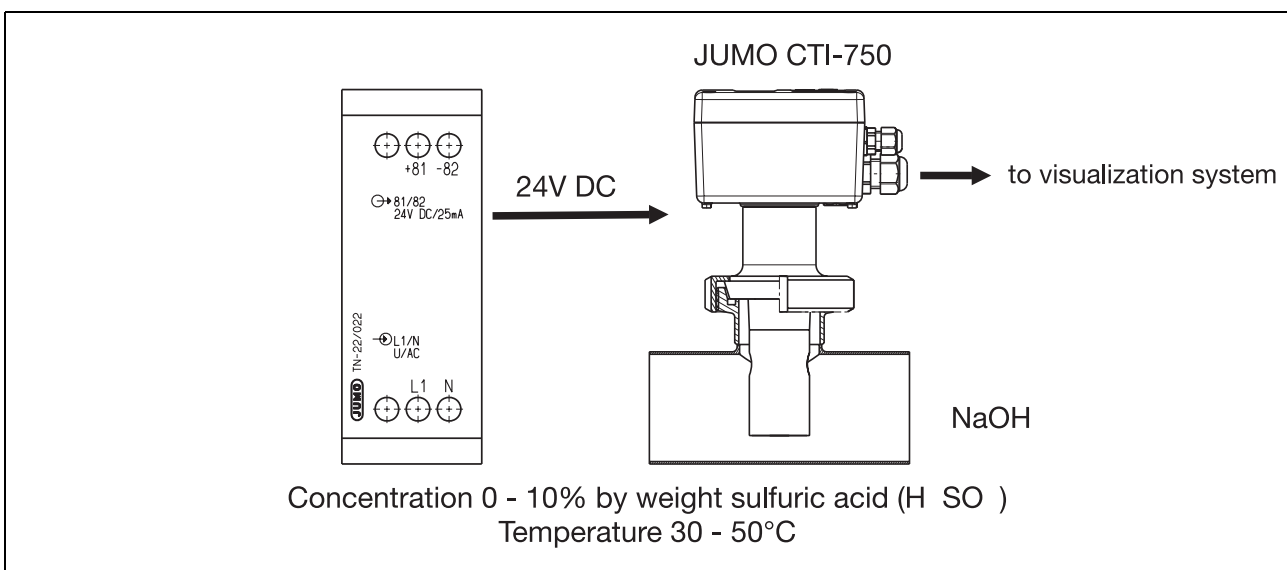

**Fig. 17: The JUMO CTI-750 calculates the actual concentration**

## 4 Applications

---

### **TDS (Total Dissolved Solids)**

This value is important for groundwater analysis, for instance, as well as for power stations. It is also used to evaluate the quality of drinking water (e. g. in the US, or in Arabic and Asiatic countries).

Various organizations have published limits in this respect.

- WHO (**W**orld **H**ealth **O**rganisation) <1000mg/liter
- USEPA (**U**nited **S**tates **E**nvironmental **P**rotection **A**gency)<500mg/liter

The value is determined, in compliance with the standard, through gravimetric analysis, which means:

- filter the sample,
- evaporate the filtrate,
- weigh the residue.

The conductivity measurement is employed for on-line measurements. Once is sufficient for determining the conversion factor. It corresponds to the ratio of the conductivity value of the water to the value for the gravimetrically determined TDS. The factor lies in the range 0.55 to 1.0. The usual value for drinking water is about 0.67.

On state-of-the-art instruments, such as the JUMO AQUIS 500 CR, this factor can be entered individually, to achieve maximum measuring accuracy.

### **Salinity**

In sea water analysis, it is customary to quote the **salinity**. Formerly, the salinity value in ‰ was related to the International Oceanographic Tables (IOT), in which the conductivity values related to a saline solution whose composition was equivalent to the average composition of sea water. Nowadays, the salinity value is dimensionless and relates to a potassium chloride solution (32.4356g/kg).

### **Sodium chloride equivalent**

In power stations, it is customary to use the sodium chloride equivalent. This value expresses the conductivity in mg/liter NaCl. This statement is based on the knowledge that sodium and chloride ions are the first to slip through the ion-exchange plant.

Wastewater treatment plants require official approval. This results in a whole list of duties arising for the operator of such a plant. Among others, these include:

- the local authority's license to discharge must be available
- where new works or modifications to sections of existing plant are carried out, a new application for a discharge license must be submitted
- prescribed limit values must be met
- if demanded, wastewater must be tested and monitored in line with the requirements.

It is very clear that the planning, construction and commissioning of wastewater treatment plants is not an easy job, and that a multitude of clauses and regulations must be observed.

# 5 Legal aspects

---

## 6 Source information

---

- APHA, AWWA, WEF,  
Standard Methods for the Examination of water and wastewater, 2510, Conductivity
- ASTM D1125-95 (Reapproved 1999),  
Standard Test Methods for Electrical Conductivity and Resistivity of Water
- ASTM D1193-99  
Standard Specification for Reagent Water
- ASTM D 5391-99  
Standard Test Method for Electrical Conductivity  
and Resistivity of a Flowing High Purity Water Sample
- DIN V EN V 13005,  
Leitfaden zur Angabe der Unsicherheit beim Messen,  
Deutsche Fassung ENV 13005:1999,  
Juni 1999
- DIN EN 27888,  
Bestimmung der elektrischen Leitfähigkeit,  
November 1993
- DIN EN 45001,  
Allgemeine Kriterien zum Betreiben von Prüflaboratorien, EN 45001:1989,  
Mai 1989
- DIN IEC 746-3,  
Angabe des Betriebsverhaltens von Elektrochemischen Analysatoren, Elektrische Leitfähigkeit,  
Januar 1988
- DIN ISO 3696,  
Wasser für analytische Zwecke,  
Juni 1991
- VGB Cooling Water Guideline, VGB-R 455 P e ,  
VGB Technischen Vereinigung der Großkraftwerksbetreiber e. V.,  
1992
- VGB-Richtlinie für Kesselspeisewasser, Kesselwasser und Dampf von Dampferzeugern  
über 68 bar zulässigem Betriebsüberdruck,  
VGB-R 450-L, VGB Technischen Vereinigung der Großkraftwerksbetreiber e. V.,  
1995
- Kremer M.,  
Dokumentierte Reinheit, Dokumentierte Reinheit von Messsystemen für Reinstwasser,  
Chemie Technik 29, Nr. 5,  
2000
- Morash K. R., Thornton R. D. ...,  
Measurement of the resistivity of high-purity water at elevated temperature,  
Ultra-pure water journal,  
1994
- United States Pharmacopeia, (USP), water conductivity <645> in der aktuellen Fassung

## 6 Source information

---

- Physikalisch-Technische Bundesanstalt,  
Rückführbare Bestimmung der elektrolytischen Leitfähigkeit,  
[www.ptb.de](http://www.ptb.de)
- Wu Y. C.,  
Absolute Determination of Electric Conductivity  
for Primary Standard KCl Solutions from 0 to 50°C,  
Journal of Solution Chemistry, Vol. 20, No. 4,  
1991

## 7.1 Sample test certificate for the measuring cell

M. K. JUCHHEIM GmbH & Co Moltkestraße 13 - 31 36039 Fulda, Germany		Telefon: 0661 6003 - 0 E-Mail: mail@jumo.net Internet: www.jumo.net		<b>JUMO</b>	
<b>Prüfprotokoll / test report</b>					
<b>1. Prüfgegenstand / Test instrument</b>					
Leitfähigkeitsmesszelle / conductivity cell :		2EL6-0,01-Pt100-Clamp A			
max. Druck / max. pressure:		16 bar (20°C)			
max. Temperatur / max. temperature :		135°C (drucklos)			
Körpermaterial / material :		1.4571			
Elektrodenmaterial / electrode material :		1.4571			
Typenblatt / data sheet :		20.2921			
Auftraggeber/ Besteller / customer :		JUMO Régulation S.A., 57075 Metz-Cédex 3			
Best.Nr. / order-no.:					
Komm.-Nr. / comm-no.:		Teile-Nr. / part-no.:	00341131	Fabr.-Nr. / fabr.-no.:	00652673 00 0 0232 0003
<b>2. Prüfverfahren / Test procedure</b>					
Die Zellenkonstante der Zwei-Elektroden-Leitfähigkeitsmesszelle wird in Anlehnung an ASTM D 1125-95 und ASTM D 5391-99 durch Vergleichsmessung ermittelt. The cell constant of the 2-electrode conductivity cell is determined with the help of ASTM D 1125-95 and ASTM D 5391-99 by comparison measurement.					
Die Leitfähigkeit der Prüflösung beträgt: The conductivity of the test liquid is:		7,86 $\mu\text{S/cm}$ .			
<b>3. Messergebnisse / Measuring results</b>					
Messwerte zum Zeitpunkt der Auslieferung. / Measuring values at the moment of delivery.					
Zellenkonstante: Cell constant:		K= 0,01029 1/cm			
Am Messumformer als relative Zellenkonstante einzugebender Wert: You have to input the following relative cell constant to the transmitter:		102,9 %			
<b>4. Messunsicherheit / Measuring uncertainty</b>					
Die Messunsicherheit liegt innerhalb der von USP25 vorgegebenen Toleranzen von +/- 2%. The measuring uncertainty is within the tolerances of +/- 2% cited in the USP25.					
<b>5. Prüfmittel und -geräte / Testing methods and -instruments</b>					
Die Prüfmittel und -geräte sind auf nationale bzw. internationale Normale rückführbar. The test methods and -instruments can be traced back to national or international normals.					
<b>6. Nächste Kalibrierung / Next calibration</b>					
Datum / date		Prüfer / signat.			
12.8.2002					
Prüfprotokoll TN 00355978/1.03	Formularname: PRUEFPR2.DOC	Speichername: (autom.) C:\EIGENE DATEIEN\PRUEFPROTOKOLLEP12-08-02_3.DOC			Seite: 1 / 1

# 7 Appendix

## 7.2 Sample calibration certificate for a transmitter

M. K. JUCHHEIM GmbH & Co  
Moltkestr. 13 - 31  
36039 Fulda, Germany

Tel.: +49 (0661) 6003 - 0  
Fax: +49 (0661) 6003 - 500  
E-Mail: mail@jumo.net  
Internet: www.jumo.net



### Calibration Certificate

Instrument: JUMO dTRANS Rw 01  
Type: 202545/10-888,888-23-00/000,000  
F-No.: 00669382 Ser.No.: 0001

**Conductivity/Resistivity input:**

Calculation of deviation:  $(1/\text{Actual} - 1/\text{Input}) / (1/\text{RangeEnd})$

Channel	rAnG	Test Input in $\Omega$	Actual in $\Omega$	Deviation in %	Status
1	14	20	19.67	0.83	OK
1	8	40	39.62	0.48	OK
1	13,19	100	99.84	0.08	OK
1	7	200	199.9	0.02	OK
1	17	200	199.8	0.04	OK
1	12	400	399.8	0.02	OK
1	18	670	670.1	-0.01	OK
1	11,16	1200	1200.	0.00	OK
1	3,6	2000	2003.	-0.09	OK
1	15	6000	5971.	0.24	OK
1	2,5,10	10000	9989.	0.05	OK
1	1,4,9	40000	40034	-0.04	OK

**Standard signal input:**

Channel	Type	Test Input	Actual	Deviation in %	Status
1	20mA	10 mA	10.00 mA	0.00	OK

**Temperature input:**

Channel	Type	Test Input in $\Omega$	Actual in $\Omega$	Deviation in %	Status
2	Pt100	100	100.10	0.12	OK
2	Pt1000	1000	1001.00	0.07	OK

**Switching outputs:**

Channel	Type	Test output	Actual	Deviation in V	Status
4	Logic 5V	5V	5.05	0.05	OK
4	Logic 12V	12V	--	--	--

**Analog outputs:**

Channel	Type	Test output	Actual	Deviation in %	Status
3	0(2)..10 V	0 V	0.00 V	-0.01	OK
3	0(2)..10 V	10 V	10.00 V	-0.01	OK
3	0(4)..20 mA	0 mA	0.00 mA	-0.02	OK
3	0(4)..20 mA	20 mA	20.00 mA	-0.02	OK
5	0(2)..10 V	0 V	0.00 V	0.01	OK
5	0(2)..10 V	10 V	10.00 V	-0.01	OK
5	0(4)..20 mA	0 mA	-0.01 mA	-0.03	OK
5	0(4)..20 mA	20 mA	20.02 mA	0.10	OK

**Functional tests:**

Keyboard:	OK	Relay output 2:	OK
Relay output 1:	OK	Relay output 5:	--
Relay output 3:	--	Binary input 2:	OK
Binary input 1:	OK	2. DC-Source for MU:	--
1. DC-Source for MU:	--		
Interface:	--		

Test instruments:	Calibrated with:
DC-Source: ADEQ 2025	FLUKE 732 DC REFERENCE STANDARD DKD-K-01901 Prüf-Nr.: 4846
Decade: Burster 1422 IEC	FLUKE 732 DC REFERENCE STANDARD DKD-K-01901 Prüf-Nr.: 4846
Current- Voltage measuring instrument: HP 34401A	FLUKE 732 DC REFERENCE STANDARD DKD-K-01901 Prüf-Nr.: 4846

All JUMO products feature a constant manufacturing control system. Adjustment and control is effected with measuring devices and systems based on the regulations of national and international norms and standards.

Date: 10.10.2002



MEASUREMENT AND CONTROL  
Analytical Measurement  
Technician: Mr. HARALD KAIB

*Harald Kaib*

## Informative material from JUMO – for beginners and those with some practical experience

Know-how is not just needed to create JUMO products, but also for their later application. That is why we offer several publications on aspects of measurement and control engineering for our users.

The publications are intended to provide step-by-step familiarization with a wide range of applications, for both beginners and those with some practical experience. They primarily illustrate general topics with JUMO-specific applications to some extent.

In addition to JUMO technical literature and our new software downloads we also offer the possibility to order our brochures and CD-ROM catalogs online.

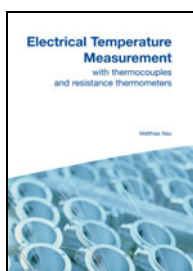

### **Electrical Temperature Measurement with thermocouples and resistance thermometers** *Matthias Nau*

FAS 146  
Sales no.: 00085081  
ISBN: 978-3-935742-07-X  
Free of charge

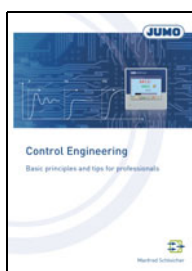

### **Control Engineering Basic principles and tips for practitioners** *Manfred Schleicher*

FAS 525  
Sales no.: 00323761  
ISBN: 978-935742-01-6  
Free of charge

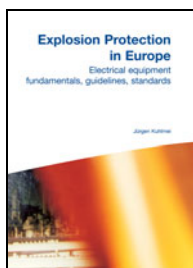

### **Explosion Protection in Europe Electrical equipment fundamentals, guidelines, standards** *Jürgen Kuhlmei*

FAS 547  
Sales no.: 000414312  
ISBN: 978-3-935742-10-X  
Free of charge

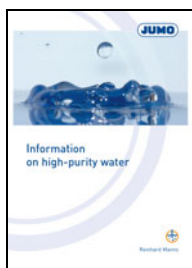

### **Information on high-purity water** *Reinhard Manns*

FAS 614  
Sales no.: 00403834  
Free of charge

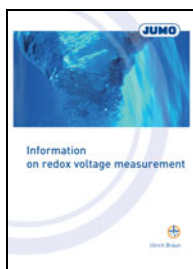

### **Information on redox voltage measurement** *Ulrich Braun*

FAS 615  
Sales no.: 00398237  
Free of charge

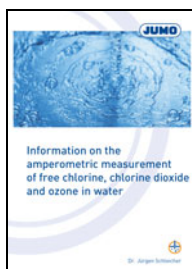

### **Information on the amperometric measurement of free chlorine, chlorine dioxide and ozone in water** *Dr. Jürgen Schleicher*

FAS 619  
Sales no.: 00398147  
Free of charge



### **SCR Power Controllers Basic principles and tips for professionals** *Manfred Schleicher, Winfried Schneider*

FAS 620  
Sales no.: 00400481  
ISBN: 978-3-935742-05-4  
Free of charge

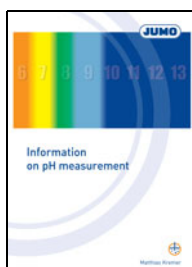

### **Information on pH measurement** *Matthias Kremer*

FAS 622  
Sales no.: 00403233  
Free of charge

## Informative material from JUMO – for beginners and those with some practical experience

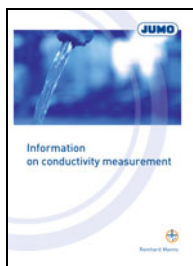

### **Information on Conductivity Measurement** *Reinhard Manns*

FAS 624  
Sales no.: 00411341  
Free of charge

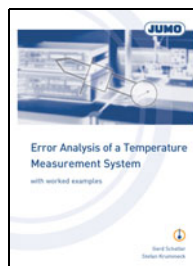

### **Error Analysis of a Temperature Measurement System with worked examples** *Gerd Scheller, Stefan Krummeck*

FAS 625  
Sales no.: 00415704  
ISBN-13: 978-3-935742-13-4  
Free of charge

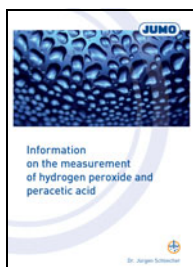

### **Information on the Measurement of Hydrogen Peroxide and Peracetic Acid** *Dr. Jürgen Schleicher*

FAS 628  
Sales no.: 00420697  
Free of charge

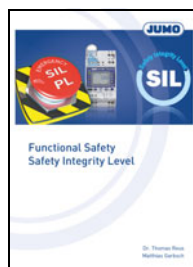

### **Functional Safety Safety Integrity Level**

*Dr. Thomas Reus, Matthias Garbsch*

FAS 630  
Sales no.: 00476107  
Free of charge

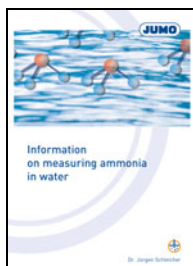

### **Information on measuring ammonia in water** *Dr. Jürgen Schleicher*

FAS 631  
Sales no.: 00485097  
Free of charge

Please visit our website [www.jumo.net](http://www.jumo.net) and familiarize yourselves with the wide variety of JUMO products for different application fields. Our website provides you with more details and information concerning the contact persons for your requirements, questions, and orders.





More than **sensors + automation**

[www.jumo.net](http://www.jumo.net)