

## Hazardous Location

**Measuring inset**  
2 RTD's or TC, which are simple apparatus: neither generate nor store more than 1.5 V; 0.1 A; 25mW resp. 20 μJ.

$L_o$  and  $C_o$  are negligible (Wire length < 1500 mm)

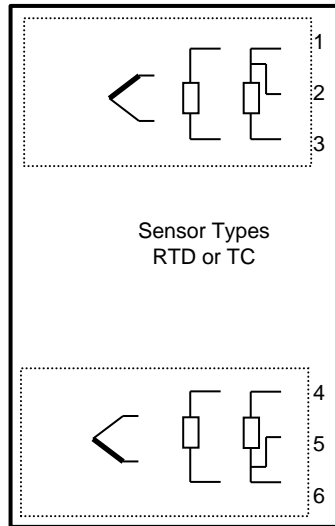

Connections integrated in housing

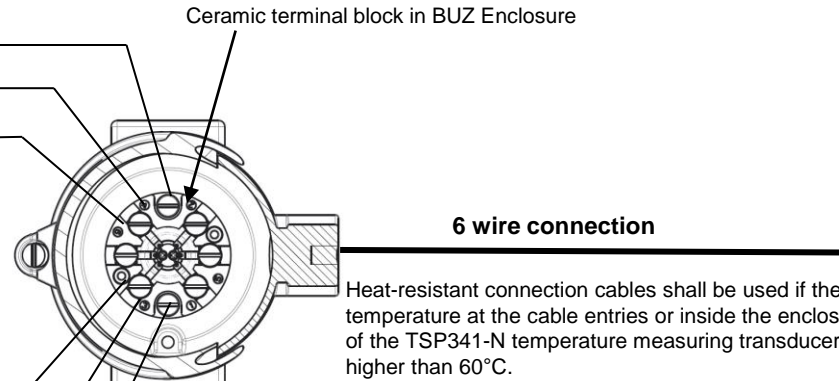

### FM intrinsically safe field circuit approval

Class I Div. 1 and Div. 2; Groups A,B,C,D  
Class I Zone 0 AEx/Ex ia IIC T6, T4 Ga  
Class I Zone 1 Aex/Ex ia IIC T6,T4 Gb

Temperature Sensor Model "TSP341-N"  
Ordering Code "TSP341-N-L1YB" contains a ceramic terminal block, that is installed in an enclosure type BUZ

### Warning:

The apparatus enclosure BUZ... contains aluminum and is considered to constitute a potential risk of ignition by impact or friction. Care must be taken into account during installation and use to prevent impact or friction.

### TTF300-N

$V_{oc} \leq 6.5$  V DC ;  
 $I_{sc} \leq 25$  mA ;  
 $P_i \leq 38$ mW

1. Transmitter must be FM approved (US) or listed for Canada (cFM/CSA) and must be installed in accordance with manufacturers instructions.
2. Transmitter sensor and cable parameters must meet the following Requirements :  
 $V_{oc}$  or  $V_t \leq V_{max}$ ;       $C_a \leq C_i + C_{cable}$ ;  
 $I_{sc}$  or  $I_t \leq I_{max}$ ;       $L_a \leq L_i + L_{cable}$   
 $P_o$  or  $P_t \leq P_{max}$
3. Install in accordance with the CE Code CSA C22.1 61010-1, or NEC (ANSI/NFPA 70) and ANSI/ISA RP12.06.01 " Part 1: Intrinsic Safety"

Surface Temperature pipe	Maximum allowable Ambient temperature at enclosure $T_{amb}$	
	Pipe without insulation	Pipe with insulation
$T_{surf}$		
T6,T5 72°C/87°C	68°C	71°C
T4 122°C	112°C	116°C
T3 187°C	106°C	113°C
T2 282°C	97°C	109°C
T1 432°C	83°C	102°C

				<b>Do not alter without FM authorization</b>			Title:		Scale:
				Approv.	2023-06-30	Peterich		TSP341-N BUZ enclosure I.S. no transmitter Control Drawing	
				Date	Name				
				<b>ABB</b> Automation Products			Drawing / Part No.:		Page : of
							<b>TSP341-N-L1YB</b>		
				Replacement of: -----					
1.00	release	2023-06-30	Peterich						
Rev.	Desc.	Date	Name						