

ABB MEASUREMENT & ANALYTICS | DATA SHEET

# TZIDC-110

## Digital Positioner



---

Compact, well-proven, and flexible

---

**For PROFIBUS PA®**

---

**Low cost of ownership**

---

**Well-proven technology**

---

**Robust and environmentally ruggedized**

---

**Wide temperature range**

- -40 to 85 °C (-40 to 185 °F)

---

**Easy to commission thanks to the 'single-button'-operating philosophy**

---

**Mechanical position indicator**

---

**ATEX, FM, CSA, EACEx and IECEx explosion protection approval**

---

**Global approval for marine applications**

- DNV

---

## Brief description

The TZIDC-110 is an electronically configurable positioner with communication capabilities designed for mounting on pneumatic linear or rotary actuators. It features a small and compact design, a modular construction, and an excellent cost-performance ratio.

Fully automatic determination of the control parameters and adaptation to the positioner allow for considerable time savings as well as optimum control behavior.

### Pneumatics

An I/P module with subsequent pneumatic amplifier is used to control the pneumatic actuator. The well-proven I/P module proportionally converts the permanent electrical setpoint signal from the CPU into a pneumatic signal used to adjust a 3/3-way valve.

Dosing of the air flow for pressurizing or depressurizing the actuator is continuously adjusted. As a result, excellent control results are achieved. When reaching the setpoint, the 3/3-way valve is closed in center position to minimize the air consumption.

The pneumatic system can be supplied in four versions: for single acting and double acting actuators and each with the 'fail-safe' / 'fail-freeze' safety function.

#### 'Fail-safe' safety function

If the electric power supply fails, the positioner output 1 is depressurized and the return spring in the pneumatic actuator moves the valve to the safe position. In case of a 'double-acting' version, output 2 is additionally pressurized.

#### 'Fail-freeze' function

If the electric power supply fails, the positioner Output 1 (and Output 2 if applicable) is closed and the pneumatic actuator blocks the valve in the current position. If the compressed air supply power fails, the positioner depressurizes the actuator.

### Use

The positioner has a built-in operating panel providing a 2-line LCD indicator and 4 operating buttons for commissioning, configuration and monitoring during live operation.

Alternatively, the appropriate configuration program can be used via the available communication interface.

### Communication

Communication with the TZIDC-110 occurs via PROFIBUS PA®.

### Modular design

The basic model can be enhanced at any time by retrofitting optional equipment.

Option modules can be installed for analog and digital position feedback.

Additionally, a mechanical position indicator, proximity switches or 24 V microswitches are available for indicating the position independently of the mother board function.

## ... Brief description

### Schematic diagram

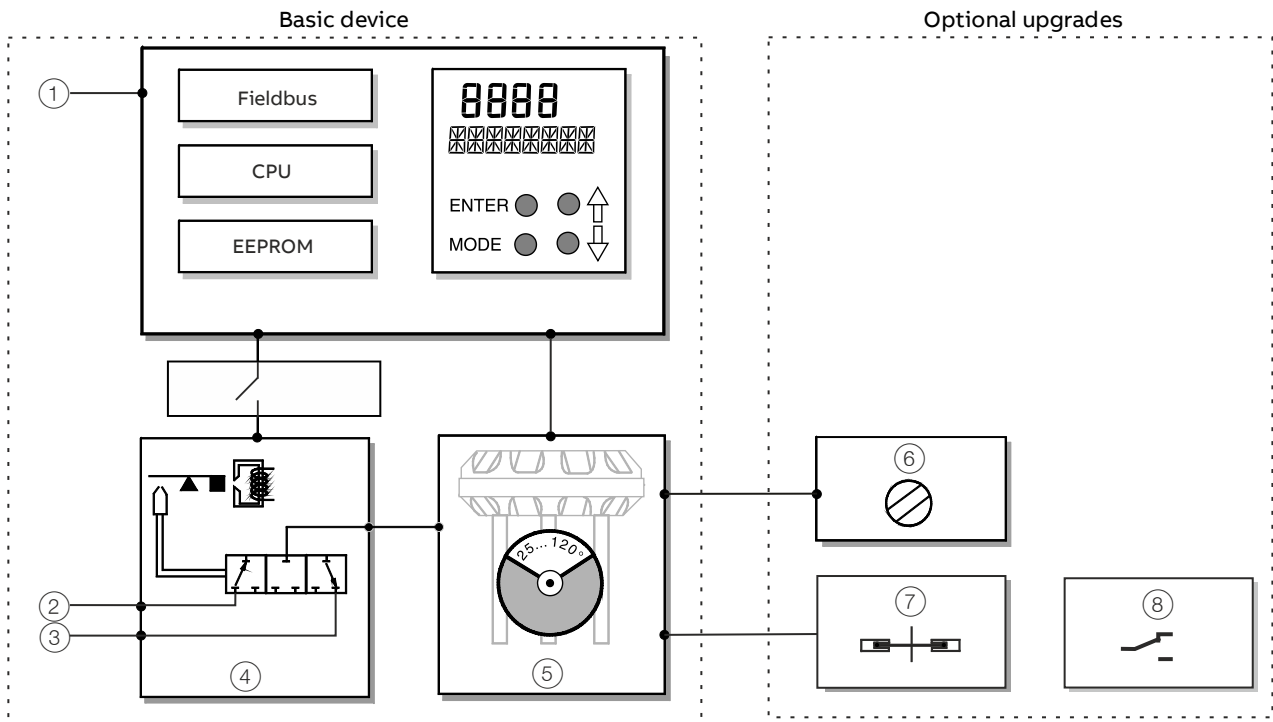

#### Basic device

- ① Fieldbus connection
- ② Supply air: 1.4 to 6 bar (20 to 90 psi)
- ③ Exhaust
- ④ I/P module with 3/3-way valve
- ⑤ Position sensor (optional up to 270° rotation angle)

#### Optional upgrades

- ⑥ Mechanical position indication
- ⑦ Feedback on the actuator position using proximity switches
- ⑧ Feedback on the actuator position using microswitches

Figure 1: Schematic diagram of the positioner

#### Note

With optional extensions, either the 'Feedback on the actuator position using proximity switches' ⑦ or the 'Feedback on the actuator position using microswitches' ⑧ can be used. In both cases though, the mechanical position indication ⑥ must be installed.

## Mounting versions

### Standardized mounting on pneumatic linear actuators

Lateral attachment is in accordance with DIN / IEC 534 (lateral attachment to NAMUR). The required attachment kit is a complete set of attachment material, but does not include the pipe fittings and air pipes.

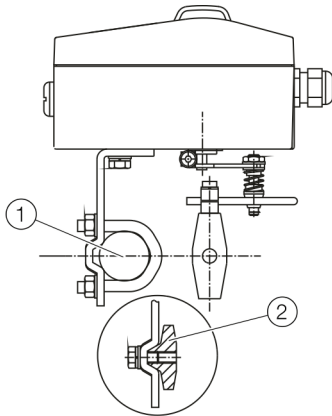

① Columnar yoke      ② Cast iron yoke

Figure 2: Mounting on linear actuators in accordance with DIN / IEC 534

### Standardized mounting on pneumatic rotary actuators

This attachment is designed for mounting according to the standard VDI / VDE 3845. The attachment kit consists of a console with mounting screws for mounting on a rotary actuator. The corresponding feedback shaft adapter has to be ordered separately. Screwed pipe connections and air pipes have to be provided on site.

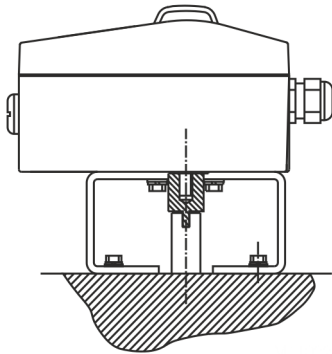

Figure 3: Mounting on rotary actuators in accordance with VDI / VDE 3845

### Integral mounting to control valves

The positioner featuring standard pneumatic action is available as an option for integral mounting.

The required holes are found at the back of the device.

The advantage of integrated mounting is that the point for mechanical stroke measurement is protected and that the positioner and actuator are linked internally. No external tubing is required.

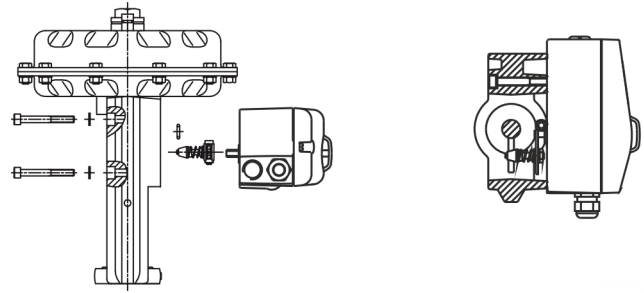

Figure 4: Integral mounting on control valves

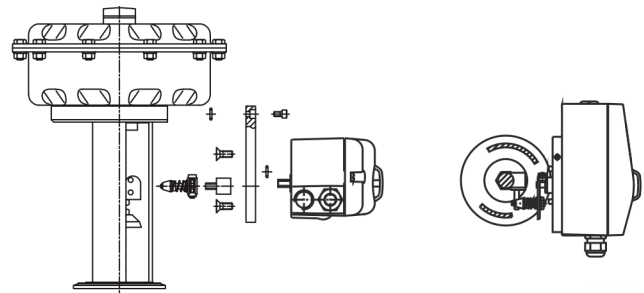

Figure 5: Integral mounting on control valves with adapter plate

### Special actuator-specific mounting versions

In addition to the mounting methods described above, there are special actuator-specific attachments.

## Device parameters

### General

Microprocessor-based position control in the positioner optimizes control. The positioner features high-precision control functions and high operational reliability. Due to their elaborate structure and easy accessibility, the device parameters can be quickly adapted to the respective application.

The total range of parameters includes:

- Operating parameters
- Adjustment parameters
- Operation monitoring parameters
- Diagnosis parameters
- Maintenance parameters

### Operating parameters

The following operating parameters can be set manually if required:

#### Signal range 0 to 100 %

Subranges are configurable, min. range 20%  
Recommended range > 50 %

Action (set point signal)

Increasing:

- Position value 0 to 100 % = direction 0 to 100 %

Decreasing:

- Setpoint signal 100 to 0 % = direction 0 to 100 %

Characteristic curve (actuator travel = f {set point signal})  
Linear, equal percentage 1:25 or 1:50 or 25:1 or 50:1 or freely configurable with 20 reference points.

#### Actuator travel limit

The actuator travel, i.e. the stroke or angle of rotation, can be reduced as needed within the full range of 0 to 100 %, provided that a minimum value of 20 % is observed.

#### Shut-off function

This parameter can be set separately for each end position. When the associated limit value is up-scaled, the function causes immediate travel of the actuator to the selected end position.

#### End Position Behavior

Selection option for behavior when moving into the end position. Either the positioner additionally pressurizes the actuator and reaches full actuating force in the end position, or it continues to control the actuator in the end position and pressurizes the actuator only as much as is required to maintain the position.

#### Actuator travel time prolongation

This function can be used to increase the max. travel time for full travel. This time parameter can be set separately for each direction.

This function can only be used with the pneumatics with the safety function 'fail-safe'.

#### Switching points for the position

You can use these parameters to define two position limit values for signaling, see option 'Module for digital position feedback'.

### Adjustment parameters

The positioner has a special function for automatic adjustment of the parameters. Additionally, the control parameters can be set manually to optimally adapt them to the process requirements.

#### Tolerance band

Upon reaching the tolerance band, the position is re-adjusted more slowly until the dead band has been reached. The factory setting for this parameter is 0,3 %.

#### Dead band (sensitivity)

When reaching the dead band, the position is held. The factory setting for this parameter is 0,1 %.

#### Actuator spring action

Selection of the direction of rotation of the sensor shaft (looking at the open housing), if the safe position is approached as a result of the spring force in the actuator (actuator is depressurized via Y1 / OUT1).

For double-acting actuators, the actuator spring action corresponds to pressurizing the pneumatic output (Y2 / OUT2).

#### Display 0 to 100 %

Adjust the display 0 to 100 % in accordance with the direction for opening or closing the final control element.

## Operations monitoring parameters

Various functions for continuous device monitoring are implemented in the operating program for the positioner. The following states will be detected and indicated, e.g.:

- Internal positioning time-out
- Sensor monitoring
- Backup monitoring

While automatic commissioning is in progress, the current state is continuously indicated on the integrated LCD indicator. Remaining messages can be retrieved via the user interface.

The fieldbus enables users to implement enhanced monitoring in the control system. A special window displays the most important process variables ONLINE, e.g. the setpoint signal (in %), the position (in %), the control deviation (in %) as well as the status messages.

## Diagnosis parameters

The diagnostics parameters in the positioner's operating program provide information about the operating conditions of the valve.

From this information the operator can derive what maintenance work is required, and when.

Additionally, limit values can be defined for these parameters.

When they are exceeded, an alarm is reported.

So, for example, the following operating values are determined:

- Number of movements of the final control element
- Sum of individual actuator travel events

The diagnostic parameters and limit values can be called up, set and reset using the configuration program.

## Operator panel

The integrated operating panel of the positioner has four operating buttons which allow the device to be operated with an open housing cover. The following functions can be controlled via the function keys:

- Observe live operation
- Manual intervention during live operation
- Parameterization of the device
- Fully automatic commissioning

The operating panel has a cover to protect against unauthorized operation.



Figure 6: TZIDC-110 with removed cover, view of the operator panel

## ... Device parameters

### ... Operator panel

#### 'One-button' commissioning

Commissioning the positioner is especially easy. Standard Auto Adjust is triggered by pressing a single operating button. Detailed configuration knowledge is not necessary in order to start the device.

Depending on the selected actuator type (linear or rotary actuator), the displayed zero position is automatically adapted:

- for linear actuators counter-clockwise (CTCLOCKW)
- for rotary actuators clockwise (CLOCKW).

Besides this standard function, a customized 'Autoadjust' function is available. The function is launched either via the operating panel or the configuration program.

#### LCD display

The multi-line LCD indicator is automatically updated during operation to provide the user with relevant information as necessary.

During control operation, the following data can be called up from the positioner by pressing the operating buttons briefly:

- Current set point (%), set point status (up button)
- Status of communication (up button)
- Operating mode on the bus and bus address (down button)
- Software version (ENTER)

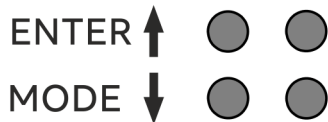
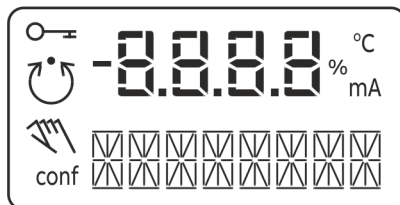

Figure 7: LCD display with operating buttons

## Communication

### General

PROFIBUS® is a manufacturer-independent, open fieldbus standard for use in the manufacturing industry and process automation. It is ideally suited for time-critical applications with high transmission rates as well as for complex communication activities. The flexible structure allows the mechanical mount and transmission speed to be easily adapted to the specific application. A standard communication protocol is used on a universal basis.

### PROFIBUS PA®

PROFIBUS PA® was developed primarily for process automation solutions.

The transmission method (physical layer in ISO reference model) complies with IEC 61158. The power supply for the field devices is provided concurrently with signal transmission via the fieldbus line. PROFIBUS PA® is also suited for use in explosion-proof installations.

### Benefits of PROFIBUS® communication

- Standardized device profiles ensure interoperability of devices from various manufacturers.
- Acyclic access to device data (even during operation) for parameterization, diagnosis and maintenance.
- High system uptimes based on comprehensive device and bus diagnostics as well as default value strategies in the event of an error.
- Support for efficient facility management through provision of operating values.

The TZIDC-110 positioner complies with the PROFIBUS PA® profile for process devices 'Electro-pneumatic actuators V3.0'. This ensures interoperability in connection with third-party control systems.

In conformance with PROFIBUS® conventions, data can be output during cyclic data transfer in operating modes AUT, MAN or RCAS and can be written in operating mode O/S (out-of-service).

Newly set parameters are saved in the non-volatile memory directly upon download to the device, and become active immediately.

### DTM

The DTM (Device Type Manager) for the positioner TZIDC-110 is based on FDT / DTM technology (FDT 1.2 / 1.2.1) and can either be integrated into a control system or loaded on a PC with an FDT framework application. This allows you to work with the same user interface in the commissioning phase, during operation, and for service tasks involving monitoring the device, parameterization, and reading out data.

### FDI – Field Device Integration

The Device Type Driver for the positioner is based on the FDI technology and can either be integrated into a control system or loaded on a PC with ABB Ability™ Field Information Manager (FIM).

This allows you to work with the same user interface in the commissioning phase, during operation, and for service tasks involving monitoring the device, setting parameters, and reading out data.

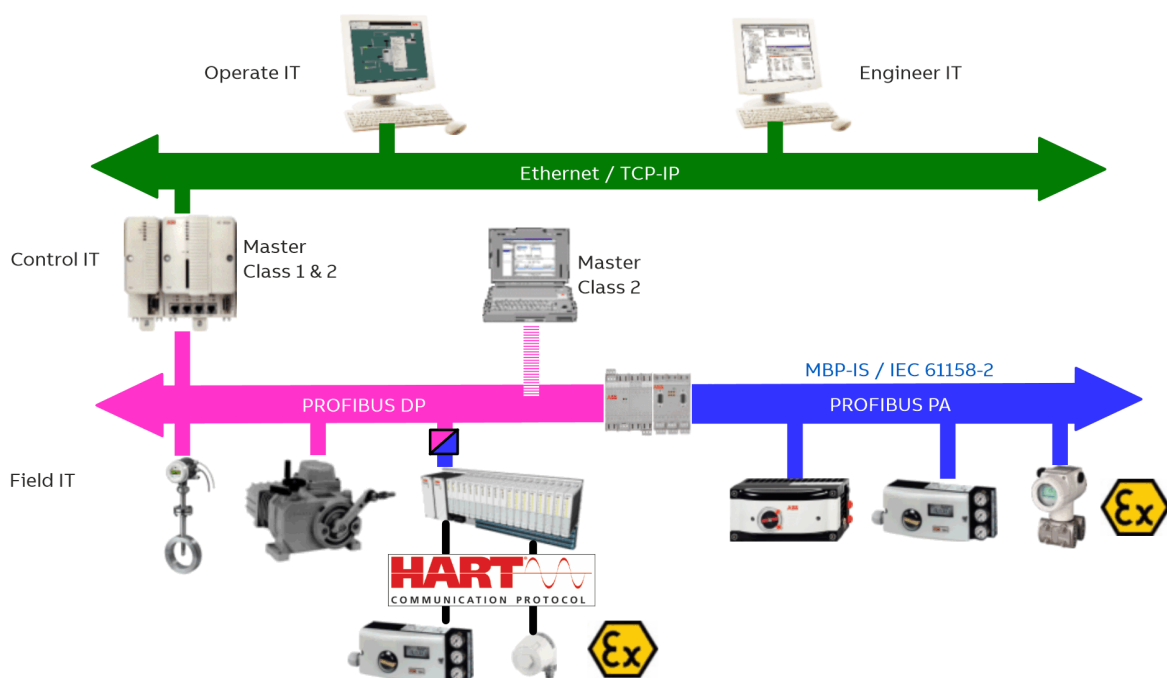

Figure 8: Communication via PROFIBUS®

## Specification

### Communication

Profiles	PROFIBUS PA® profile for process devices, electro-pneumatic actuators V3.0.
Block types	1 AO Functional block 1 transducer block 1 physical block
Physical Layer	In compliance with IEC 61158-2
Transmission rate	31.25 Kbit/s
Supply voltage	Power feed from the PA bus 9.0 to 32.0 V DC
Max. permissible voltage	35 V DC
Input Current	10.5 mA
Current in the event of an error	15 mA (10.5 mA + 4.5 mA)

### Designation

Device name	TZIDC-X10
PNO ID no.	0x0639
Device ID	0X3200028xyz
Bus address	Between 0 and 126, default address is 126

### Actuator travel

<b>Rotation angle</b>	
Meas. range	270°
Operating range for linear actuators	min. 25°, max. 45°
Operating range for rotary actuators	min. 25°, max. <270°, see <b>Figure 9</b>
Actuator travel limit	Min. and max. limits, freely configurable in range of 0 to 100 % of total travel (min. range > 20 %)
Actuator travel time prolongation	Setting range of 0 to 200 seconds, separately for each direction
Dead band time limit	Setting range 0 to 200 seconds (monitoring parameter for the control deviation until the dead band is reached)

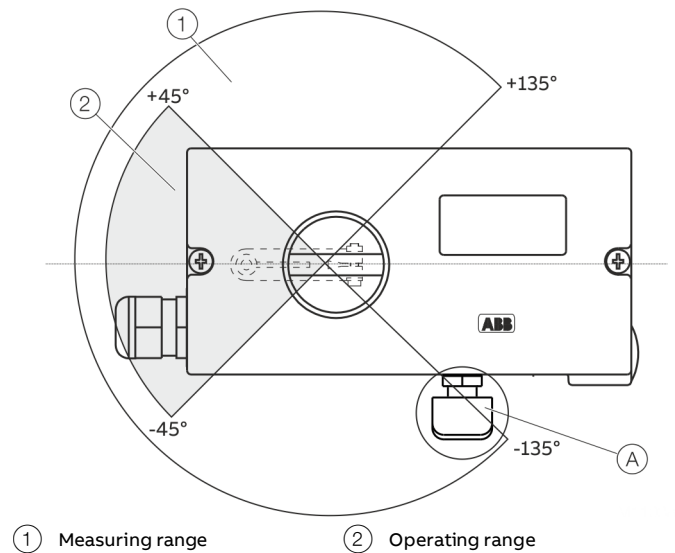

Figure 9: Measuring and operating ranges of the positioner

## Pneumatic connections

Cable	Air Pipe
Thread ½-14 NPT	Thread ¼-18 NPT
Thread M20 × 1.5	Thread ¼-18 NPT
Thread M20 × 1.5	Thread G ¼
Thread G ½	Thread Rc ¼

(Optional: with cable gland(s) and blind plugs as necessary)

### Compressed air output

Range	Standard design: 0 to 6 bar (0 to 90 psi) Marine version: 0 to 5.5 bar (0 to 80 psi)
Air capacity	> 5 kg/h = 3.9 Nm <sup>3</sup> /h = 2.3 scfm at 1.4 bar (20 psi) supply air pressure > 13 kg/h = 10 Nm <sup>3</sup> /h = 6 scfm at 6 bar (90 psi) supply air pressure
Output function	For single acting or double acting actuators Air is vented from actuator / actuator is blocked in case of (electric) power failure
Shut-off values	End position 0 % = 0 to 45 % End position 100 % = 55 to 100 %

### Instrument air<sup>1), 2)</sup>

Purity	Maximum particle size: 5 µm Maximum particle density: 5 mg/m <sup>3</sup>
Oil content	Maximum concentration 1 mg/m <sup>3</sup>
Pressure dew point <sup>2)</sup>	10 K below operating temperature
Supply pressure <sup>3)</sup>	Standard design: 1.4 to 6 bar (20 to 90 psi) Marine version: 1.6 to 5.5 bar (23 to 80 psi)
Air consumption <sup>4)</sup>	< 0.03 kg/h / 0.015 scfm

- 1) Free of oil, water and dust in accordance with DIN / ISO 8573-1, pollution and oil content according to Class 3 (except for natural gas variant)
- 2) Nitrogen is permitted as instrument air. When operating with nitrogen, the pressure dew point specifications for operation with instrument air apply.
- 3) Do not exceed the maximum output pressure of the actuator
- 4) Independent of supply pressure

## Accessories

### Mounting material

- Attachment kit for linear actuators in accordance with DIN / IEC 534 / NAMUR
- Attachment kit for rotary actuators in accordance with VDI / VDE 3845
- Attachment kit for integral mounting
- Attachment kit for actuator-specific mounting

### Pressure gauge block

- With pressure gauges for supply air and output pressure. Pressure gauges with housing ø 28 mm (1.10 in), with connection block in aluminum, black
- Installation material in black for mounting on positioner

### Filter regulator

All metal version in brass, varnished black, bronze filter element (40 µm), with condensate drain.  
Max. pre-pressure 16 bar (232 psi).

Output can be adjusted to:

- 1.4 to 6 bar (20 to 90 psi)

Marine version:

- 1.6 to 5.5 bar (23 to 80 psi)

The filter regulator may only be installed in combination with the pressure gauge block (accessory).

### Control program for operation and parameterization on a PC

- DTM bundle for TZIDC for download at <http://www.abb.com/positioners>.
- ABB Ability™ Field Information Manager (FIM) and FDI package for download at: [solutions.abb/fieldinfo](http://solutions.abb/fieldinfo).

## Housing

### Material / IP rating

Aluminum with ≤ 0.1% copper

IP rating	IP 65 / NEMA 4X (NEMA 4X does not permit overhead mounting), (IP 66, optional)
-----------	---

### Surface/color

Dipping varnish	With epoxy resin, stove-hardened
Housing varnished matt black	RAL 9005
Case cover	Pantone 420

### Weight

Aluminum	1.7 kg (3.75 lb)
----------	------------------

### Mounting orientation

Any

## ... Specification

### Transmission data and contributing factors

Output Y1	
Increasing set point signal	0 to 100 % Increasing pressure at output
Decreasing set point signal	0 to 100 % Decreasing pressure at output

#### Action (set point signal)

Increasing set point	4 to 20 mA = actuator position 0 to 100 %
Decreasing set point	20 to 4 mA = actuator position 0 to 100 %

#### Characteristic curve (actuator travel = f {set point signal})

Linear	Equal percentage 1:25 or 1:50 or 25:1 or 50:1*
Deviation	≤ 0.5 %
Tolerance band	0.3 to 10 %, adjustable
Configurable dead zone	0.1 to 10 %, adjustable
Resolution (AD-conversion)	> 16,000 steps
Sampling frequency	20 ms
Ambient temperature effect	≤ 0.5 % per 10 K
Reference temperature	20 °C
Influence of vibration	≤ 1 % to 10 g and 80 Hz

\* freely configurable with 20 reference points

### Seismic vibration

Meets requirements of DIN / IEC 60068-3-3 Class III for strong and strongest earthquakes.

### Influence of mounting orientation

Not measurable.

### Noise emissions

Max. 100 db (A)

Noise-reduced version max. 85 db (A)

### Ambient conditions

Ambient temperature range	
During operation, storage, and transport	-40 to 85 °C (-40 to 185 °F)

#### Relative humidity

During operation with housing closed and air supply switched on	95 % (annual average), condensation permissible.
Transport and storage	75 % (annual average)

### Expected service life of the device

With proper use and consideration of relevant environmental conditions, the service life of the TZIDC-110 can reach approx. 10 years.

Regular maintenance work and / or proper repairs by ABB Service, along with the use of ABB spare parts, can extend the service life of the TZIDC-110.

## Electromagnetic compatibility

Requirement	Component	Standard reference	Test level	Assessment criteria	
				Required	Complied
ESD contact discharge	Chassis	DIN EN 61000-4-2	±4 kV	B	A
ESD air discharge	Chassis	DIN EN 61000-4-2	±8 kV	B	A
Burst 5 kHz	Input/output signals	DIN EN 61000-4-4	±2 kV	B	A
Surge line – line	Input/output signals	DIN EN 61000-4-5	±1 kV	B	A*
Surge line – ground	Input/output signals	DIN EN 61000-4-5	±2 kV	B	A*
radiated interference immunity 80 MHz to 6 GHz	Chassis	DIN EN 61000-4-3	10 V/m	A	A
conducted interference immunity 150 kHz to 80 MHz	Input/output signals	DIN EN 61000-4-6	10 V	A	A
supply frequency magnetic fields	Chassis	DIN EN 61000-4-8	30 A/m	A	A

\* In the event of line surge load on the plug-in module for analog feedback AO, the analog output signal meets assessment criteria B in accordance with DIN EN 61000-4-5.

### Assessment criteria A:

The device must work as intended during and after the test.

### Assessment criteria B:

Impairment in operating performance of the device is permitted during the test. The device must continue to work as intended after the test.

## Electrical connections

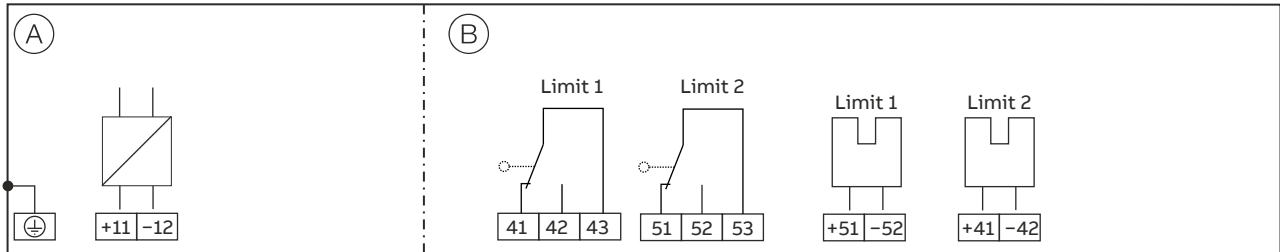

(A) Basic device

(B) Options, Mechanical digital feedback with proximity switches or microswitches

Figure 10: Electrical connection TZIDC-110

## Connections for inputs and outputs

Terminal	Function/comments
+11 / -12	Fieldbus, bus feed
+51 / -52	Limit 1 – Feedback on the actuator position using proximity switches (optional)
+41 / -42	Limit 2 – Feedback on the actuator position using proximity switches (optional)
41 / 42 / 43	Limit 1 – Feedback on the actuator position using microswitches (optional)
51 / 52 / 53	Limit 2 – Feedback on the actuator position using microswitches (optional)

### Note

The TZIDC-110 can be equipped **either** with feedback on the actuator position using proximity switches **or** using microswitches. It is not possible to combine both variants.

## Electrical data for inputs and outputs

### Bus Connection

Terminals	+11 / -12
Supply voltage	Power feed from the PA bus 9 to 32 V DC
Max. permissible voltage	35 V DC
Input Current	10.5 mA
Current in the event of an error	15 mA (10.5 mA + 4.5 mA)

### Note

These options are also available for retrofitting by Service.

### Mechanical digital feedback

Two proximity switches or microswitches for independent signaling of the actuator position, switching points are adjustable between 0 bis 100 %.

### Feedback on the actuator position using proximity switches Limit 1, Limit 2

Terminals	+41 / -42, +51 / -52	
Supply voltage	5 to 11 V DC (Control circuit in accordance with DIN 19234/NAMUR)	
Direction of action	Metal tag in the proximity switch	Metal tag outside the proximity switch
Type S12-SN (NC; log 1)	< 1.2 mA	> 2.1 mA

### Feedback on the actuator position using microswitches Limit 1, Limit 2

Terminals	+41 / -42, +51 / -52
Supply voltage	maximum 24 V AC/DC
Load rating	Maximum 2 A
Contact surface	10 µm Gold (AU)

### Mechanical position indication

Indicator disk in enclosure cover linked with device feedback shaft.

## Dimensions

All dimensions in mm (in)

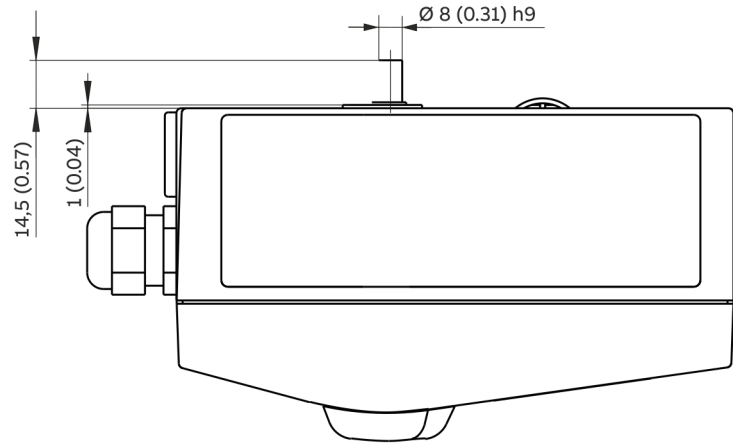
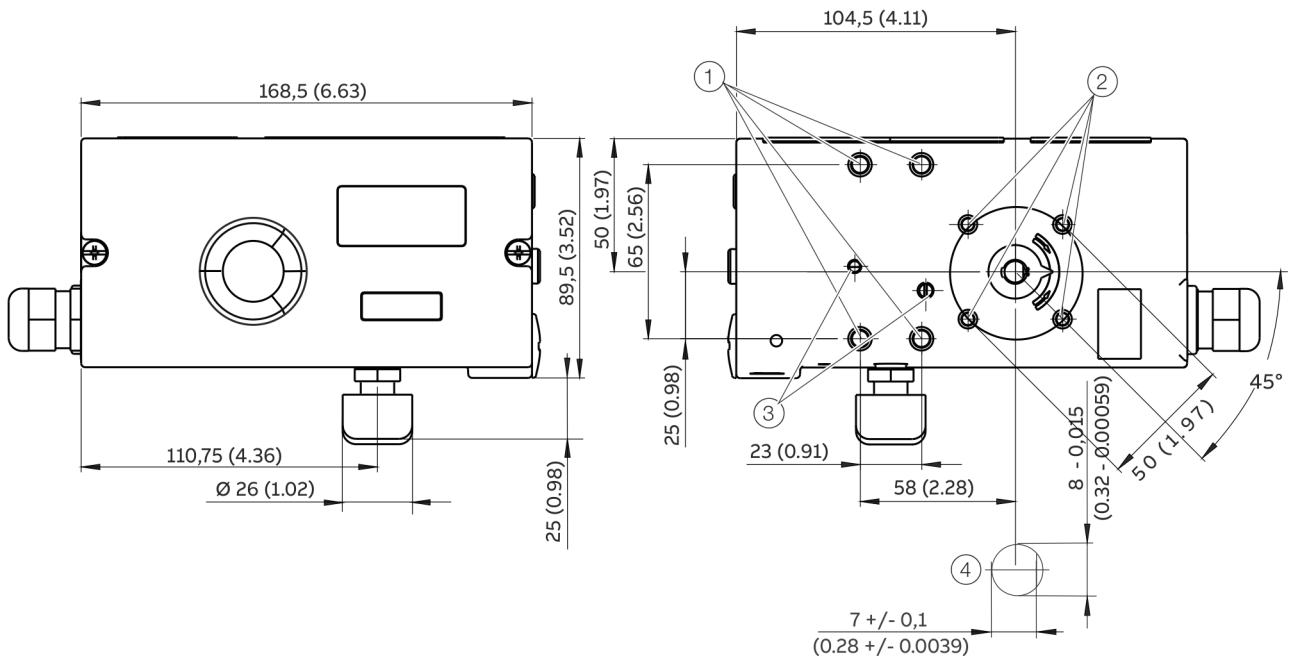

Figure 11: Top view



① Tap hole M8 (10 mm [0.39 in] deep)

② Tap hole M6 (8 mm deep [0.31 in])

③ Threaded hole M5 × 0.5 (air outputs for direct mount)

④ Sensor shaft (shown larger than scale)

Figure 12: Front and rear view



## ... Dimensions

### ... Electrical data for inputs and outputs

All dimensions in mm (in)

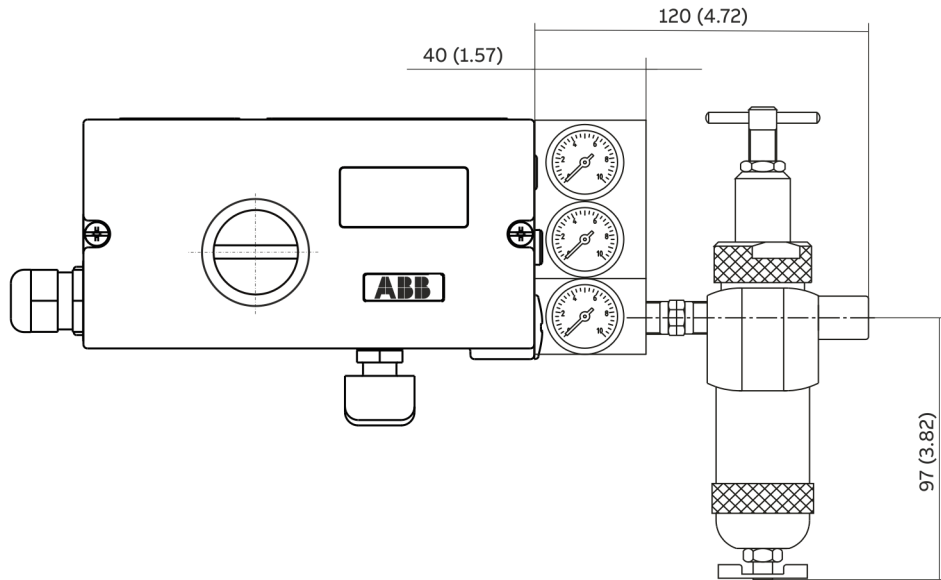

Figure 16: Positioner DS\_TZIDC-110\_EN\_H with mounted pressure gauge block and filter regulator

## Use in potentially explosive atmospheres

### General requirements

- The ABB positioner has been approved only for appropriate and intended use in standard industrial atmospheres. Any breach of this rule leads to a cancellation of warranty and manufacturer's responsibility!
- Make sure that only devices which comply with the types of protection relevant to the applicable zones and categories are installed.
- All electric equipment has to be suited for the respective intended use.

### Approvals and certifications

The digital positioner TZIDC-110 has a variety of different explosion protection approvals. The scope of these approvals extends over the entire EU, Switzerland, and special countries.

They range from explosion protection approvals in accordance with ATEX directives to internationally recognized approvals such as IECEx, and additionally include country-specific explosion protection approvals.

#### Explosion protection approvals

- ATEX / UKEX, details see for Ex i page 23 for Ex ec page 24.
- IECEx, details see for Ex i page 25 for Ex ec page 26.
- cFMus, for details, see page 27.
- EAC TR-CU-012, details see for Ex i page 37 for Ex n .

#### Standards applied

The standards including the date of issue with the devices are in compliance are specified in the EU Type examination certificate and in the declaration of conformity of the manufacturer.

### Product identification

Depending on the type of explosion protection, Ex-marking is attached to the positioner on the right, next to the main name plate.

This indicates the level of explosion protection and the device's relevant Ex certificate.

#### Marking (name plate)



Figure 17: Ex marking (example, ATEX / IECEx)



Figure 18: Ex marking (example, cFMus)



Figure 19: Ex marking (example, EAC Ex)

## ... Use in potentially explosive atmospheres

### Commissioning, Installation

The ABB positioner has to be mounted in a major system. Depending on the degrees of IP-protection, an interval for cleaning the equipment (dust settlement) has to be defined. Strict care has to be taken that only devices which comply with the types of protection relevant to the applicable zones and categories is installed.

When installing the device, the locally applicable installation regulations, such as EN 60079-14, must be observed.

Other important facts to be observed:

- The electric circuits of the positioner must be put into operation in all zones by persons qualified in accordance with TRBS 1203. The details on the type label are mandatory for doing this.
- The device has been designed in accordance with IP 65 (optionally IP 66) and must be protected accordingly against adverse ambient conditions.
- In accordance with the selected Ex approval, the information in the EU type examination certificate or the Ex certificates must be observed, including the special conditions defined in them.
- The device may only be used in accordance with its intended use.
- The device may only be connected when de-energized.
- The potential equalization of the system must be established in accordance with installation regulations applicable in the respective country (VDE 0100, Part 540, IEC 364-5-54).
- Circulating currents must not be guided through the housing!
- Make sure that the housing is properly installed and that its IP rating has not been compromised.
- In potentially explosive atmospheres, assembly may be conducted only in compliance with locally applicable installation regulations. The following conditions have to be observed (incomplete):
  - Assembly and maintenance may only be conducted if there is no explosion hazard in the area and you have a hot work permit.
  - The TZIDC-110 may be operated in a fully mounted and intact housing only.

### Notes for operation

- The positioner must be integrated in the local potential equalization system.
- Only either intrinsically safe or non intrinsically safe circuits may be connected. A combination is not permitted.
- If the positioner is operated with non intrinsically safe circuits, later use for the intrinsic safety type of protection is not permitted.

### Use, Operation

The TZIDC-110 is approved for proper and intended use only. In case of non-compliance, the warranty and manufacturer's liability do no longer apply!

- Only those auxiliary components which fulfill all the requirements of European and national standards may be used in potentially explosive atmospheres.
- The ambient conditions specified in the operating instruction must be strictly followed.
- The TZIDC-110 is approved for proper and intended use in standard industrial atmospheres only. Where aggressive substances are present in the air, the manufacturer has to be consulted.

## Maintenance, repair

Definition of terms according to IEC 60079-17:

### Maintenance

Defines a combination of actions performed to maintain or restore the condition of an item such that the item meets the requirements of the relevant specification and performs its required functions.

### I →Analyzer module without electronics module (power supply):

Defines an action which involves careful inspection of an item (either without disassembly or with partial disassembly, as required) supplemented by measurements, aimed at achieving a reliable conclusion regarding the condition of the item.

### Visual inspection

Defines an inspection which identifies defects which are visible to the naked eye, such as missing screws, without the use of access equipment and tools.

### Close inspection

Defines an inspection which encompasses the aspects covered by a visual inspection and in addition, identifies defects such as loose screws, which can only be detected with the use of access equipment (e.g. steps) and tools.

### Detailed inspection

Defines an inspection which encompasses the aspects covered by a close inspection and in addition, identifies defects, such as loose connections, which can only be detected by opening the housing and / or by using tools and test devices, as needed.

- Maintenance and exchange work may be conducted by qualified specialists only, i.e., qualified personnel in accordance with TRBS 1203 or similar.
- Only those auxiliary components which fulfill all the requirements of European and national guidelines and regulations may be used in potentially explosive atmospheres.
- Maintenance works that require disassembly of the system may only be performed in non-hazardous areas. If that is not possible, however, the usual precautions have to be ensured according to local regulations.
- Components may only be replaced by original spare parts which are therefore approved for use in potentially explosive atmospheres.
- The device must be regularly cleaned when used in potentially explosive atmospheres. The intervals must be defined by the operator in compliance with the ambient conditions present at the operating location.
- After all maintenance and repair work has been completed, any barriers and plates removed for that purpose must be put back in their original place.
- The flameproof joints differ from the tables of IEC 60079-1 and may be repaired by the manufacturer only.

Activity	Visual inspection (every 3 months)	Close inspection (every 6 months)	Detailed inspection (every 12 months)
Visual inspection of the positioner for integrity, removal of dust deposits	●		
Inspection of electric installation for integrity and proper operation			●
Inspection of the entire installation		Responsibility of the operator	

## ... Use in potentially explosive atmospheres

### Preconditions for safe operation of the positioner

#### **DANGER**

##### **Risk of explosion due to hot parts**

Hot parts inside the device pose an explosion hazard.

- Never open the device immediately after switch-off.
- A waiting time of at least four minutes should be observed before opening the device.

When using in hazardous areas, observe the following points:

- Observe the specification and special conditions applicable for the device in accordance with the relevant valid certificate.
- Manipulation of the device in any form by the user is not permitted. Only the manufacturer or an explosion protection specialist may modify the device
- The IP 65 / NEMA 4x IP rating is only achieved if the splash guard is screwed in place. Operating the unit without splash guard cap is prohibited.
- The device may only be operated using instrument air that is free from oil, water and dust. The use of flammable gas, oxygen, or oxygen-enriched gas is not permitted.

#### **Cable gland**

- Limited temperature range of the M20 × 1.5 plastic cable gland for explosion protection variants:
  - The permissible ambient temperature range is –20 to 80 °C (–4 to 176 °F).
- When using the cable gland, make sure that the ambient temperature is within this range, plus 10 K or according to the minimum ambient temperature.
- The cable gland must be installed in the housing with a tightening torque of 3.8 Nm. When installing the connection of the cable gland and cable, check for tightness to ensure that the required IP rating is met.
- To ensure the required IP rating, NPT Cable glands have to be installed with approx. 1.5 layers of sealing tape or similar sealing, wrapped around the thread.

## ATEX / UKEX

### Note

The values indicated here are taken from the respective certificates. Always observe the specifications and supplements in the explosion protection certificates.

### ATEX / UKEX – ‘Ex i’ type of protection

#### Ex-marking

Ex marking	
Marking	II 2 G Ex ia IIC T6, T4...T1 Gb II 2 G Ex ib IIC T6, T4 ...T1 Gb
Type examination certificate (ATEX)	TÜV 04 ATEX 2702 X
Certificate (UKEX)	EMA22UKEX0032X
Type	Intrinsically safe equipment
Device class	II 2G
Standards	EN 60079-0, EN 60079-11

#### Temperature data

Temperature class	Ambient temperature $T_a$
T4 to T1	-40 to 85 °C
T6	-40 to 40 °C*

### Electric Data

With the ‘Intrinsic safety Ex i IIC’ type of protection, only for connection to a certified FISCO power supply unit or a barrier, i.e., a power supply unit with maximum values according to the following tables:

#### Connection to a barrier or power supply unit

Current circuit (terminal)	Electrical information (maximum values)	
Signal circuit (+11 / -12)	Voltage:	24 V
	Current:	250 mA
	Power:	1.2 w
	$L_p, C_i$	Negligible
	Characteristic	rectangular curve:

#### Connection to a FISCO power supply unit

Current circuit (terminal)	Electrical information (maximum values)	
Signal circuit (+11 / -12)	Voltage:	17.5 V      17.5 V
	Current:	380 mA      360 mA
	Power:	5.32 w      2.52 W
	$L_p, C_i$	Negligible
	Characteristic	rectangular      trapezoidal curve:

#### Current circuit (terminal) Electrical information (maximum values)

Feedback on the actuator For maximum values, see EU-Type examination position using proximity certificate PTB 00 ATEX 2049 X Pepperl & Fuchs switches, (Pepperl & Fuchs Type 2 proximity switches SJ2-SN)

(Limit1: +51 / -52),

(Limit2: +41 / -42)

Local communication interface (LCI)	Only for connection to a programming device using an ABB LCI adapter ( $U_m \leq 30$ V DC) outside the hazardous area.
-------------------------------------	--

### Special conditions

- Permissible for the ‘Natural gas version’ only:
  - The positioner TZIDC-110 may be operated as a power supply only with gases of Group IIA and temperature class T1 outdoors or inside of buildings with sufficient ventilation.
  - The supplied gas must be free of air and oxygen to prevent the forming of a hazardous atmosphere.
  - Exhaust gas must always be discharged outside.
- The equipment may only be used as a II 2D type device TZIDC-110 in areas where the level of mechanical danger is "low".
- For TZIDC-110 electrostatic charging caused by propagating brush discharge should be prevented when the device is used for applications involving combustible dust.
- For devices that are operated in an intrinsically safe manner, cable and wire entries should be used that meet the requirements of EN 60079-11 for Category II 2G as well as the ambient temperature range.
- The ‘local communication interface’ (LCI) of the TZIDC-110 may only be operated at  $U_m \leq 30$  V DC outside the hazardous area.

## ... Use in potentially explosive atmospheres

### ... ATEX / UKEX

#### ATEX / UKEX – ‘Ex ec’ type of protection

##### Ex-marking

Ex marking	
Marking	II 3 G Ex ec IIC T6, T4 ... T1 Gc
Type examination certificate (ATEX)	TÜV 02 ATEX 1943 X
Certificate (UKEX)	EMA22UKEX0032X
Type	Type of protection ‘ec’
Device class	II 3 G
Standards	EN 60079-7, EN 60079-0

##### Temperature data

Temperature class	Ambient temperature Ta
T4 to T1	-40 to 85 °C
T6	-40 to 50 °C

##### Electric Data

Current circuit (terminal)	Electrical information (maximum values)
Signal circuit (+11 / -12)	U = 9 to 32 V DC I = 10.5 mA
Feedback on the actuator position using proximity switches, (Pepperl & Fuchs SJ2-SN) (Limit1: +51 / -52), (Limit2: +41 / -42)	For maximum values, see EU-Type examination certificate PTB 00 ATEX 2049 X Pepperl & Fuchs Type 2 proximity switches
Local communication interface (LCI)	Only for connection to a programming device using an ABB LCI adapter (Um ≤ 30 V DC) outside the hazardous area.

##### Special conditions

In the case of TZIDC-110, the following shall apply for safe use in the Ex ‘ec IIC’ type of protection:

- Only devices that are suited for operation in hazardous areas of Zone 2 and the conditions prevailing at the place of use may be connected to circuits in Zone 2 (manufacturer's declaration or certificate from the test center).
- For the ‘Mechanical digital feedback with Pepperl & Fuchs SJ2-SN proximity switches’ circuit, external measures must be implemented outside of the device to prevent the rated voltage from being up-scaled by more than 40 % in the event of transient disturbances.
- It is only permissible to connect, disconnect, and switch live circuits during installation or maintenance, or for the purpose of carrying out repairs.

##### Note

It is considered very unlikely that a potentially hazardous atmosphere would be present in Zone 2 at the same time that installation or maintenance or repair work was being carried out.

- Only non-flammable gases must be used for pneumatic power supply.
- Only cable entries may be used that suit the requirements of EN 60079-7 or EN 60079-15.

## IECEX

### IECEX – ‘Ex i’ type of protection

#### Ex-marking

Ex marking	
Marking	Ex ia IIC T6 / T4...T1 Gb Ex ib IIC T6 / T4...T1 Gb
Type Examination Test Certificate	IECEX TUN 04.0015X
Type	Intrinsic safety ‘i’
Standards	IEC 60079-0, IEC 60079-11

#### Temperature data

Temperature class	Ambient temperature Ta
T4 to T1	-40 to 85 °C
T6	-40 to 40 °C*

#### Electric Data

With the ‘Intrinsic safety Ex i IIC’ type of protection, only for connection to a certified FISCO power supply unit or a barrier, i.e., a power supply unit with maximum values according to the following tables:

#### Connection to a barrier or power supply unit

Current circuit (terminal)	Electrical information (maximum values)	
Signal circuit (+11 / -12)	Voltage:	24 V
	Current:	250 mA
	Power:	1.2 w
	L <sub>p</sub> , C <sub>i</sub>	Negligible
	Characteristic rectangular curve:	

#### Connection to a FISCO power supply unit

Current circuit (terminal)	Electrical information (maximum values)	
Signal circuit (+11 / -12)	Voltage:	17.5 V      17.5 V
	Current:	380 mA      360 mA
	Power:	5.32 w      2.52 W
	L <sub>p</sub> , C <sub>i</sub>	Negligible
	Characteristic rectangular curve:	rectangular      trapezoidal

#### Current circuit (terminal) Electrical information (maximum values)

Feedback on the actuator For maximum values, see EU-Type examination position using proximity certificate PTB 00 ATEX 2049 X Pepperl & Fuchs switches, (Pepperl & Fuchs Type 2 proximity switches SJ2-SN)

(Limit1: +51 / -52),

(Limit2: +41 / -42)

Local communication interface (LCI)	Only for connection to a programming device using an ABB LCI adapter (U <sub>m</sub> ≤ 30 V DC) outside the hazardous area.
-------------------------------------	---

#### Special conditions

- Permissible for the ‘Natural gas version’ only:
  - The positioner TZIDC-110 may be operated as a power supply only with gases of Group IIA and temperature class T1 outdoors or inside of buildings with sufficient ventilation.
  - The supplied gas must be free of air and oxygen to prevent the forming of a hazardous atmosphere.
  - Exhaust gas must always be discharged outside.
- The equipment may only be used as a II 2D type device TZIDC-110 in areas where the level of mechanical danger is "low".
- For TZIDC-110 electrostatic charging caused by propagating brush discharge should be prevented when the device is used for applications involving combustible dust.
- For devices that are operated in an intrinsically safe manner, cable and wire entries should be used that meet the requirements of EN 60079-11 for Category II 2G as well as the ambient temperature range.
- The ‘local communication interface’ (LCI) of the TZIDC-110 may only be operated at U<sub>m</sub> ≤ 30 V DC outside the hazardous area.

## ... Use in potentially explosive atmospheres

### ... IECEx

#### IECEx – ‘Ex na’ and ‘Ex ec’ type of protection

##### Ex-marking

IECEx Ex ec	
Marking	Ex ec IIC T6 resp. T4...T1 Gc
Type Examination Test Certificate	IECEx TUN 04.0015X
Type	Increased safety „e“
Standards	IEC 60079-0, IEC 60079-7

##### IECEx Ex nA

Marking	Ex nA IIC T6 resp. T4...T1 Gc
Type Examination Test Certificate	IECEx TUN 04.0015X
Type	Type of protection „n“
Standards	IEC 60079-0, IEC 60079-15

##### Temperature data

Temperature class	Ambient temperature Ta
T4 to T1	-40 to 85 °C
T6	-40 to 50 °C

##### Electric Data

Current circuit (terminal)	Electrical information (maximum values)
Signal circuit (+11 / -12)	U = 9 to 32 V DC I = 10.5 mA
Feedback on the actuator position using proximity switches, (Pepperl & Fuchs SJ2-SN) (Limit1: +51 / -52), (Limit2: +41 / -42)	For maximum values, see EU-Type examination certificate PTB 00 ATEX 2049 X Pepperl & Fuchs switches, Type 2 proximity switches
Local communication interface (LCI)	Only for connection to a programming device using an ABB LCI adapter (Um ≤ 30 V DC) outside the hazardous area.

##### Special conditions

In the case of TZIDC-110, the following shall apply for safe use in the Ex ‘ec IIC’ type of protection:

- Only devices that are suited for operation in hazardous areas of Zone 2 and the conditions prevailing at the place of use may be connected to circuits in Zone 2 (manufacturer's declaration or certificate from the test center).
- For the ‘Mechanical digital feedback with Pepperl & Fuchs SJ2-SN proximity switches’ circuit, external measures must be implemented outside of the device to prevent the rated voltage from being up-scaled by more than 40 % in the event of transient disturbances.
- It is only permissible to connect, disconnect, and switch live circuits during installation or maintenance, or for the purpose of carrying out repairs.

##### Note

It is considered very unlikely that a potentially hazardous atmosphere would be present in Zone 2 at the same time that installation or maintenance or repair work was being carried out.

- Only non-flammable gases must be used for pneumatic power supply.
- Only cable entries may be used that suit the requirements of EN 60079-7 or EN 60079-15.

## cFMus

### Ex-marking

---

#### TZIDC-110

**Model number: V18346-1032b20c0d**

**Model number: V18346-3032b20c0d**

**Model number: V18346-5032b20c0d**

IS / I, II, III / 1 / ABCDEFG / T6, T4 Ta = 40°C, 85°C – 901265; Entity, FISCO

NI / I / 2 / ABCDEFG / T6, T4 Ta = 40°C, 85°C

Type 4X; IP65

Max Entity Parameters: Per Control Drawings

Certificate FM20US0122X and FM20CA0061X

---

#### Model number details

- b Set output / safety position: 1, 2, 4 or 5
- c Optional upgrade with mechanical digital feedback: 0, 1 or 2
- d Design (Paint / marking): 1, H or S

---

#### TZIDC-110

**Model number: V18346-2032b20c0d**

**Model number: V18346-4032b20c0d**

**Model number: V18346-6032b20c0d**

IS / I / 1 / ABCD / T6, T4 Ta = 40°C, 85°C – 901265; Entity, FISCO

IP65

Max Entity Parameters: Per Control Drawings

Certificate FM20US0122X and FM20CA0061X

---

#### Model number details

- b Set output / safety position: 1, 2, 4 or 5
- c Optional upgrade with mechanical digital feedback: 0, 1 or 2
- d Design (Paint / marking): 1, H or S

---

#### TZIDC-110

**Model number: V18346-103Qb20c0d**

**Model number: V18346-303Qb20c0d**

**Model number: V18346-503Qb20c0d**

I / 1 / AEx ia IIC / T6...T4 Gb

21 / AEx ia IIIC / T85°C...T125°C Db

IS / I, II, III / 1 / ABCDEFG / T6, T4 Ta = 40°C, 85°C – 901265 - Entity, FISCO

NI / I / 2 / ABCDEFG / T6, T4 Ta = 40°C, 85°C

Type 4X; IP65

Max Entity Parameters: Per Control Drawings

Certificate FM20US0122X and FM20CA0061X

---

#### Model number details

- b Set output / safety position: 1, 2, 4 or 5
- c Optional upgrade with mechanical digital feedback: 0, 1 or 2
- d Design (Paint / marking): 1, H or S

---

#### TZIDC-110

**Model number: V18346-203Qb20c0d**

**Model number: V18346-403Qb20c0d**

**Model number: V18346-603Qb20c0d**

I / 1 / AEx ia IIC / T6...T4 Gb

IS / I / 1 / ABCD / T6, T4 Ta = 40°C, 85°C – 901265 - Entity, FISCO

IP65

Max Entity Parameters: Per Control Drawings

Certificate FM20US0122X and FM20CA0061X

---

#### Model number details

- b Set output / safety position: 1, 2, 4 or 5
- c Optional upgrade with mechanical digital feedback: 0, 1 or 2
- d Design (Paint / marking): 1, H or S

## ... Use in potentially explosive atmospheres

### ... cFMus

#### Commissioning, installation

The ABB positioner has to be mounted in a major system. Depending on the degrees of IP-protection, an interval for cleaning the equipment (dust settlement) has to be defined. Strict care has to be taken that only such equipment is installed that complies with the types of protection relevant to the applicable zones and categories.

When installing the equipment, the locally applicable rules on erection, have to be observed, see **Page 4 of 5** on page 34 to **Page 5 of 5** on page 35.

Other important facts to be observed:

- The equipment is constructed for IP 66 and has to be protected accordingly in adverse ambient conditions.
- The Certificates have to be taken into account including any special conditions defined therein.
- The equipment shall only be used as intended.
- The equipment is only to be connected when de-energized.
- The potential equalization of the system has to be established according to the regulations of erection applicable in the respective country of use, see **Page 4 of 5** on page 34 to **Page 5 of 5** on page 35. For installation according to the North American Zone concept the external grounding is supplementary.
- Circulating currents shall not be led via the enclosures!
- It has to be ensured that the enclosure is properly installed and that its IP protection is not impaired.
- Inside the potentially explosive atmospheres' assembly shall only be performed taking the locally applicable rules of erection into account.

The following conditions have to be observed (incomplete):

- Assembly and maintenance to be done only if atmosphere is Ex-free and a permit for hot works is in place.
- The TZIDC-110 is only to be operated in a fully mounted and intact enclosure.
- Outside of the housing is a connector for the equipotential bonding.
 

The following opportunities are available:

  - Direct connection of single-strand wires of up to 2.5 mm<sup>2</sup> or
  - Direct connection of fine wires of up to 1.5 mm<sup>2</sup> or
  - Connection of cross-sections of up to 6 mm<sup>2</sup> using a ring or spade terminal with 4 mm drill hole.
- For proper selection of cables see electrical installation instructions in the original manufacturer's manual. Use cables rated at least 20 K greater than the ambient temperature.
- High / recurring charging processes in gas areas must be excluded by the operator.

#### Notes for operation

- The positioner shall be included in the local equipotential bonding system
- Either only intrinsically or non intrinsically safe circuits shall be connected. A combination is not permitted.
- When the Positioner is operated with non intrinsically safe circuits, the subsequent use for type of protection Intrinsic Safety is not permitted.

### Special conditions for the safe use of intrinsically safe positioners

#### Special conditions

- The 'Local communication interface (LCI)' may only be used outside of the explosion hazardous area with  $U_m \leq 30 \text{ V DC}$ .
- Measures of lightning protection have to be provided by the user.

#### Special conditions for safe use of Positioners non I.S.

- Only devices which are suitable for the operation in explosion hazardous areas declared as zone 2 and the conditions available at the place of operation are allowed to be connected to circuits in the zone 2.
- The connecting and disconnecting as well as the switching of circuits under voltage are only permitted during installation, for maintenance or repair purposes.

#### Note

The temporal coincidence of explosion hazardous atmosphere and installation, maintenance resp. repair purposes is assessed as improbable.

- For the circuit 'Position feedback with proximity switches or microswitches' measures have to be taken outside the device that the rated voltage is exceeded not more than 40 % by transient disturbances.
- Only non combustible gases are allowed to be used as pneumatic auxiliary energy.
- Only suitable cable entries which meet the requirements of IEC 60079-15 are allowed to be used.

### Use, operation

The TZIDC-110 is only approved for intended and appropriate use. In case of non-compliance, the warranty and manufacturer's liability do no longer apply!

- In explosive atmospheres only such auxiliary components shall be used that meet all requirements of the European and the national standards.
- The ambient conditions specified in the instruction manual have to be adhered to strictly.
- The TZIDC-110 has only been approved for its appropriate and intended use in standard industrial atmospheres. Where aggressive substances are present in the air, the manufacturer has to be consulted.

### Maintenance, repair

Maintenance: defines a combination of any actions carried out to retain an item in, or restore it to, conditions in which it is able to meet the requirements of the relevant specification and perform its required functions.

#### Inspection:

defines any action comprising careful scrutiny of an item carried out either without dismantling, or with the addition of partial dismantling as required, supplemented by means such as measurement, in order to arrive at reliable conclusion as to the condition of an item.

#### Visual inspection:

defines an inspection which identifies, without the use of access equipment and tools, those defects, such as missing bolts, which will be apparent to the eye.

#### Close inspection:

defines an inspection which encompasses those aspects covered by a visual inspection and, in addition, identifies those defects, such as loose bolts, which will be apparent only by the use of access equipment, for example steps, where necessary, and tools.

#### Detailed inspection:

defines an inspection which encompasses those aspects covered by a close inspection and, in addition, identifies those defects, such as loose terminations, which will only be apparent by opening the enclosure, and/or using, where necessary, tools and test equipment.

## ... Use in potentially explosive atmospheres

### ... cFMus

- Maintenance or replacement works are to be carried out by qualified personnel only, i.e. personnel qualified according to TRBS 1203 or similar.
- Only such auxiliary components may be used in explosive atmospheres which meet all requirements of European and national directives and legislation.
- Maintenance works that require a dismantling of the system shall only be performed if the atmosphere is Ex-free. If that is not possible, however, the usual precautions have to be ensured according to local regulations.
- Components shall only be replaced by original spare parts which are therefore approved for the use in explosive atmospheres.
- Inside the Ex-atmosphere the equipment has to be cleaned regularly. The intervals are to be defined by the user in compliance with the environmental conditions present at the place of operation.
- After maintenance and repair works have been performed, all barriers and notes removed for that purpose have to be put back in their original place.
- The flameproof joints differ from the tables of IEC 60079-1 and should only be repaired by the manufacturer.

### Warning markings

- “TO PREVENT IGNITION OF FLAMMABLE GASES OR VAPORS, DO NOT REMOVE COVER WHILE CIRCUITS ARE LIVE”  
“POUR ÉVITER L'INFLAMMATION DE GAZ OU DE VAPEURS INFLAMMABLES, NE PAS RETIRER LE COUVERCLE LORSQUE LES CIRCUITS SONT SOUS TENSION.”
- “FOR PROPER SELECTION OF CABLES SEE ELECTRICAL INSTALLATION INSTRUCTIONS IN THE MANUAL”  
“POUR LA SÉLECTION APPROPRIÉE DES CÂBLES, VOIR LES INSTRUCTIONS D'INSTALLATION ÉLECTRIQUE DANS LE MANUEL”

If the equipment was tested according to the exception of table 5 from FM class 3615, the label shall contain the statement:

- “SEAL ALL CONDUITS WITHIN 18 INCHES”  
“SCELLER TOUS LES CONDUITS À MOINS DE 18 POUCES”

Equipment supplied with a factory-installed conduit seal shall be marked with the words:

- “FACTORY SEALED, CONDUIT SEAL NOT REQUIRED”  
“SCELLÉ EN USINE, JOINT DE CONDUIT NON REQUIS”

### Activity

Activity	Visual inspection every 3 months	Close inspection every 6 months	Detailed inspection every 12 months
Visual inspection of positioner for intactness, removal of dust settlements	●		
Check of electrical system for intactness and functionality			●
Check of entire system	User's responsibility		

### Fault elimination

No changes or modifications may be performed on equipment that is operated in conjunction with explosive atmospheres. Such equipment shall only be repaired by expert personnel trained and authorized to do so.

**FM installation drawing No. 901265**

Page 1 of 5

**FM-CONTROL-DOCUMENT\_901265**

1. Entity concept / Ex ec (TZIDC, TZIDC-110/-120)								
	Concept	Groups	Vmax (V)	I <sub>max</sub> (mA)	P <sub>max</sub> (W)	C <sub>i</sub> (nF)	L <sub>i</sub> (μH)	Comment
Terminals +11, -12	Entity	IIC / ABCD	30	320	1.1	6.6	-	Analog Input
	FISCO	IIC / ABCD	17.5	183	-			Input
	FISCO	IIB / CD	17.5	380	-			Input
Terminals +31, -32	Entity	IIC / ABCD	30	320	1.1	6.6	-	Analog Position Feedback
Terminals +41, -42; +51, -52	Entity	IIC / ABCD	30	320	0.25	3.7	-	Digital Feedback
Terminals +41, -42; +51, -52	Entity	IIC / ABCD	16	25	0.064	60	100	Limit switches
Terminals +81, -82	Entity	IIC / ABCD	30	320	1.1	14.5	-	Digital Input
Terminals +83, -84	Entity	IIC / ABCD	30	320	0.5	14.5	-	Digital Output

2. Intrinsic safety / Ex I (TZIDC, TZIDC-110/-120)								
	Concept	Groups	Vmax (V)	I <sub>max</sub> (mA)	P <sub>max</sub> (W)	C <sub>i</sub> (nF)	L <sub>i</sub> (μH)	Comment
Terminals +11, -12	Intrinsic safe	IIC / IIIC / ABCDEFG	30	320	1.1	6.6	-	Analog Input
	FISCO	IIC / IIIC / ABCDEFG	17.5	183	-			Input
	FISCO	IIB / IIIC / CDEFG	17.5	380	-			Input
Terminals +31, -32	Intrinsic safe	IIC / IIIC / ABCDEFG	30	320	1.1	6.6	-	Analog Position Feedback
Terminals +41, -42; +51, -52	Intrinsic safe	IIC / IIIC / ABCDEFG	30	320	0.25	3.7	-	Digital Position Feedback
Terminals +41, -42; +51, -52	Intrinsic safe	IIC / IIIC / ABCDEFG	16	25	0.064	60	100	Limit switches
Terminals +81, -82	Intrinsic safe	IIC / IIIC / ABCDEFG	30	320	1.1	14.5	-	Digital Input
Terminals +83, -84	Intrinsic safe	IIC / IIIC / ABCDEFG	30	320	0.5	14.5	-	Digital Output

3. Flameproof / Ex d (TZIDC-200/-210/-220)								
	Concept	Groups	Vmax (V)	I <sub>max</sub> (mA)	P <sub>max</sub> (W)	C <sub>i</sub> (nF)	L <sub>i</sub> (μH)	Comment
Terminals +11, -12	Flameproof	IIC / ABCDEFG	30					Analog Input
	FISCO	IIC / ABCDEFG	17.5	183				Input
	FISCO	IIB / CDEFG	17.5	380				Input
Terminals -31, -32	Flameproof	IIC / ABCDEFG	30					Analog Position Feedback
Terminals +51, -52; +41, -42	Flameproof	IIC / ABCDEFG	30					Digital Position Feedback
Terminals +51, -52; +41, -42	Flameproof	IIC / ABCDEFG	30					Mechanical Digital Feedback
Terminals +41, -42; +51, -52	Flameproof	IIC / ABCDEFG	16					Limit switches

Ambient temperature TZIDC-200/-210/-220 Temperature class T5 = -40°C to 82°C

8		2022-02-19	Pet.	2003	Date	Name	<b>ABB</b> Automation Products	Title FM-Control-Document  No change without notice to FM  Drwg.-No. (Part-No.) <b>901265</b>	Scale /     Page -1/5-
7	DIP marking removed	2021-06-23	Ste	Name	27.03.03	Thiem.			
6		2020-04-28	Ste	Appr.					
5		2011-07-08	Thie	Std.					
4		2009-10-07	Lasa.						
3		2006-06-26	Thie.						
2		2006-05-22	Thie.						
1		2006-03-27	Thie.						
Rev.	Change	Date	Name				Supersedes Dwg. :	Part Class:	

... Use in potentially explosive atmospheres

... cFMus

**FM-CONTROL-DOCUMENT\_901265**

Non-Hazardous Location	HAZARDOUS (CLASSIFIED) LOCATION Class I, II, III Div. I & 2 Group A-G Class I Zone 1, 21 Group IIC or IIB/ IIIC	
Any FM/CSA Approved Associated Apparatus		
	TZIDC-xxx	
	+11	Analog Input
	-12	Analog Input
	+31	Analog Position Feedback / Limit Switches
	-32	Analog Position Feedback / Limit Switches
	+41	Digital Position Feedback /
	-42	Digital Position Feedback
	+51	Digital Position Feedback/ Limit Switches
	-52	Digital Position Feedback/ Limit Switches
	+81	Digital Input
	-82	Digital Input
	+83	Digital Output
	-84	Digital Output
	→Any FM/ CSA Approved Terminator (maynot be necessary for Entity Installations)	
	<b>Ambient temperature dependent on temperature class</b>	
	<b>Type and Marking</b>	<b>TZIDC, TZDIC-110/-120</b>
	Ambient temperature	Gas atmosphere      Dust atmosphere
		Temperature class      Ambient temperature
	-40 °C to 85 °C	T4                      T 125°C
	-40 °C to 40 °C	T6                      T 85°C

8		2022-02-19	Pet.	2003	Date	Name	Title <b>FM-Control-Document</b>	Scale  /
7	DIP marking removed	2021-06-23	Ste	Name	27.03.03	Thiem.		
6		2020-04-28	Ste	Appr.			No change without notice to FM	Page -2/5-
5		2011-07-08	Thie	Std.				
4		2009-10-07	Lasa.	<b>ABB</b> Automation Products			Drwg.-No. (Part-No.) <b>901265</b>	
3		2006-06-26	Thie.					
2		2006-05-22	Thie.					
1		2006-03-27	Thie.					
Rev.	Change	Date	Name				Supersedes Dwg. :	Part Class:

**FM-CONTROL-DOCUMENT\_901265****FISCO rules**

The FISCO Concept allows the interconnection of intrinsically safe apparatus to associated apparatus not specifically examined in such combination.

The criterion for such interconnection is that the voltage ( $V_{max}$ ), the current ( $I_{max}$ ) and the power ( $P_i$ ) which intrinsically safe apparatus can receive and remain intrinsically safe, considering faults, must be equal or greater than the voltage ( $U_o, V_{oc}, V_t$ ), the current ( $I_o, I_{sc}, I_t$ ) and the power ( $P_o$ ) which can be provided by the associated apparatus (supply unit).

In addition, the maximum unprotected residual capacitance ( $C_i$ ) and inductance ( $L_i$ ) of each apparatus (other than the terminators) connected to the Fieldbus must be less than or equal to 5 nF and 10  $\mu$ H respectively.

In each I.S. Fieldbus segment only one active source, normally the associated apparatus, is allowed to provide the necessary power for the Fieldbus system.

The allowed voltage ( $U_o, V_{oc}, V_t$ ) of the associated apparatus used to supply the bus must be limited to the range of 14V d.c. to 24V d.c.

All other equipment connected to the bus cable has to be passive, meaning that the apparatus is not allowed to provide energy to the system, except to a leakage current of 50  $\mu$ A for each connected device.

Separately powered equipment needs a galvanic Isolation to insure that the intrinsically safe Fieldbus circuit remains passive.

The cable used to interconnect the devices needs to comply with the following parameters:

Loop resistance	R': 15...150 $\Omega$ /km
Inductance per unit length	L': 0.4...1mH/km
Capacitance per unit length	C':80...200 nF / km
	C' = C' line/line + 0.5C' line/screen, if both lines are floating or
	C' = C' line/line + C' Line/screen, if the screen is connected to one line
Length of spur cable:	max. 30m
Length of trunk cable:	max. 1km
Length of splice:	max. 1m

**Terminators**

At each end of the trunk cable an approved line terminator with the following parameters is suitable:

- R = 90...100  $\Omega$
- C = 0...2.2  $\mu$ F.

**System evaluation**

The number of passive devices like transmitters, actuators, connected to a single bus segment is not limited due to I.S. Reasons. Furthermore, if the above rules are respected, the inductance and capacitance of the cable need not to be considered and will not impair the intrinsic safety of the installation.

8		2022-02-19	Pet.	2003	Date	Name	Title FM-Control-Dokument	Scale /
7	DIP marking removed	2021-06-23	Ste	Name	27.03.03	Thiem.		
6		2020-04-28	Ste	Appr.				
5		2011-07-08	Thie	Std.				
4		2009-10-07	Lasa.	<b>ABB</b> Automation Products			No change without notice to FM	
3		2006-06-26	Thie.				Drwg.-No. (Part-No.) <b>901265</b>	Page -3/5-
2		2006-05-22	Thie.					
1		2006-03-27	Thie.					
Rev.	Change	Date	Name				Supersedes Dwg. :	Part Class:

## ... Use in potentially explosive atmospheres

### ... cFMus

Page 4 of 5

## FM-CONTROL-DOCUMENT\_901265

### Installation Notes

#### A. Installation notes for all ignition protection methods

- Control equipment connected to the Associated Apparatus must not use or generate more than 250 Vrms or Vdc.
- Installation should be in accordance with ANSI/ISA RP12.6 (except chapter 5 for FISCO Installations) "Installation of Intrinsically Safe System for Hazardous (Classified) Locations" and the National Electrical Code® (ANSI/NFPA 70) Sections 504 and 505.
- Output current must be limited by a resistor such that the output voltage current plot is a straight line drawn between open circuit voltage and short circuit current
- The operation of the local communication interface (LKS) and of the programming interface (X5) is only allowed outside of the Hazardous explosive area.
- Tampering and replacement with non-factory components may adversely affect the safe use of the system. Substitution of components may impair suitability for hazardous locations.
- For FM Div. 2 use: Do not connect or disconnect unless the power was switched off or the area is known to be non hazardous
- Preventing electrostatic charging
- Due to the possibility of impermissible electrostatic charging of the housing occurring, the effects of high-voltage sources on the equipment must be prevented. Electrostatic charging can also occur if the device is wiped with a dry cloth or if large amounts of dust flow around the device in dusty environments.
- To prevent charging of this type from occurring, the C, device may only be cleaned using a damp cloth.
- Dust flowing round the device should be prevented by installing a flow restrictor or partition.

#### B. Installation Notes for I.S.

- The Intrinsic Safety Entity concept allows the interconnection of FM/CSA Approved Intrinsically safe devices with entity parameters not specifically examined in combination as a system when:
  - $U_0$  or  $V_{OC}$  or  $V_t \leq V_{max}$ ,  $I_0$  or  $I_{sc}$  or  $I_t \leq I_{max}$ ,  $P_0 \leq P_i$ .  $C_a$  or  $C_o \geq \sum C_i + \sum C_{cable}$ .
  - For inductance use either  $L_a$  or  $L_o \geq \sum L_i + \sum L_{cable}$  or  $L_c / R_c \leq (L_a / R_a \text{ or } L_o / R_o)$  and  $L_i / R_i \leq (L_a / R_a \text{ or } L_o / R_o)$
- The Intrinsic Safety FISCO concept allows the interconnecting of FM/CSA Approved Intrinsically safe devices with FISCO parameters not specifically examine in combination as a system when:  $U_0$  or  $V_{OC}$  or  $V_t \leq V_{max}$ ,  $I_0$  or  $I_{sc}$  or  $I_t \leq I_{max}$ ,  $P_0 \leq P_i$ .
- The configuration of associated Apparatus must be Factory Mutual Research /Canadian Standards Association Approved under the associated concept.
- Associated Apparatus manufacturer's installation drawing must be followed when installing this equipment.
- Caution: Substitution of components may impair intrinsic safety.
- To maintain intrinsic safety, wiring associated with each channel must be run in separate cable shields connected to intrinsically safe (associated apparatus) ground.

8		2022-02-19	Pet.	2003	Date	Name	Title	Scale
7	DIP marking removed	2021-06-23	Ste	Name	27.03.03	Thiem.		
6		2020-04-28	Ste	Appr.			No change without notice to FM	
5		2011-07-08	Thie	Std.				
4		2009-10-07	Lasa.	<b>ABB</b> Automation Products				
3		2006-06-26	Thie.					
2		2006-05-22	Thie.					
1		2006-03-27	Thie.					
Rev.	Change	Date	Name				Supersedes Dwg. :	Part Class:

**FM-CONTROL-DOCUMENT\_901265****C. Installation notes for flameproof housing**

17. Dust-tight conduit seal must be used when installed in Class II and Class III environments.
18. When connecting conduit to the enclosure use conduit hubs that have the same environmental rating as the enclosure

**D. NONINCENDIVE, CLASS I, DIV. 2, GROUP A, B, C, D, AND FOR CLASS II AND III, DIV. 1&2, GROUP E, F, G HAZARDOUS LOCATION INSTALLATION**

1. Install per National Electrical Code (NEC) using threaded metal conduit. Intrinsic safety barrier required. Max. Supply voltage 30 V. For T-code see table.
2. A dust tight seal must be used at the conduit entry when the positioner is used in a Class II & III Location.
3. **WARNING:** Explosion Hazard – do not disconnect equipment unless power has been switched off or the area is known to be Non-Hazardous.  
**WARNING:** Substitution of components may impair suitability for hazardous locations.

FM-901265 FM-Control-Documents Rev.8

8		2022-02-19	Pet.	2003	Date	Name	Title	Scale
7	DIP marking removed	2021-06-23	Ste	Name	27.03.03	Thiem.		
6		2020-04-28	Ste	Appr.			No change without notice to FM	
5		2011-07-08	Thie	Std.				
4		2009-10-07	Lasa.	<b>ABB</b> Automation Products				
3		2006-06-26	Thie.					
2		2006-05-22	Thie.					
1		2006-03-27	Thie.				Supersedes Dwg. :	Part Class:
Rev.	Change	Date	Name					

## ... Use in potentially explosive atmospheres

### EAC TR-CU-012

#### EAC TR-CU-012 Ex i

##### Ex marking

Ex marking	
Marking	1Ex ia IIC T6/T4 Gb X 2Ex ic IIC T6/T4 Gc X
Certificate	EAC TR-CU-012
Type	Intrinsically safe equipment
Standards	EN 60079-0, EN 60079-11

##### Temperature Data

Temperature class	Ambient temperature Ta
T4	-40 to 85 °C
T6	-40 to 40 °C

##### Temperature characteristic curves

Intrinsically safe circuit according to ATEX and EAC / TR CU 012/2011

- Equipment Category 1: Use in Zone 0
- Equipment Category 2: Use in Zone 1
- Equipment Category 3: Use in Zone 2

##### Electrical Data

#### ia / ib / ic for Grp. IIB / IIC

With the intrinsically safe Ex i IIC type of protection, only for connection to a certified FISCO power supply unit, a barrier or a power supply unit with linear characteristic curves and the following maximum values:

Current circuit (terminal)	Electrical information (maximum values)	
Signal circuit (+11 / -12 or + / -)	$U_i = 24 \text{ V}$ $I_i = 250 \text{ mA}$ $P_i = 1.2 \text{ W}$	Characteristic curve: linear $L_i < 10 \mu\text{H}$ $C_i < 5 \text{ nF}$

With the intrinsically safe Ex i IIC type of protection, only for connection to a certified intrinsically safe circuit with maximum values:

Current circuit (terminal)	Electrical information (maximum values)
Feedback on the actuator position using proximity switches, (Pepperl & Fuchs SJ2-SN) (Limit1: +51 / -52) (Limit2: +41 / -42)	For maximum values see EU type examination certificate PTB 00 ATEX 2049 X / RU C-DE.AA87.B.00394 proximity switches produced by Pepperl & Fuchs Type 2

##### Special conditions

- Devices must only be connected to circuits in zone 2 if they are suitable for operation in zone 2 potentially explosive atmospheres and for the conditions prevailing at the installation location (manufacturer's declaration or certificate from an inspection authority).
- Power supply for the 'Mechanical digital feedback with Pepperl & Fuchs SJ2-SN proximity switches' circuit must be provided intrinsically safe and in accordance with PTB 00 ATEX 2049 X / RU C-DE.AA87.B.00394 certificate according to application type 2.
- It is only permissible to connect, disconnect, and switch live circuits during installation or maintenance, or for the purpose of carrying out repairs.

##### Note

- It is considered very unlikely that a potentially hazardous atmosphere would be present in Zone 2 at the same time that installation or maintenance or repair work was being carried out.
- Only non-flammable gases must be used for pneumatic power supply.
- Only use suited cable entries that meet the requirements of EN 60079-15.

**EAC TR-CU-012 Ex n****Ex marking**

<b>Ex marking</b>	
Marking	2Ex nA II T6/T4 Gc X
Certificate	EAC TR-CU-012
Type	'n' type of protection
Device class	II 3 G
Standards	EN 60079-15, EN 60079-0

**Temperature Data**

<b>Temperature class</b>	<b>Ambient temperature Ta</b>
T4	-40 to 85 °C
T6	-40 to 50 °C

**Electrical Data**

<b>Current circuit (terminal)</b>	<b>System bus, computer interfaces</b>
Signal circuit (+11 / -12)	U = 9 to 32 V DC I = 10.5 mA
Feedback on the actuator position using proximity switches, (Pepperl & Fuchs SJ2-SN)	For maximum values see EU type examination certificate PTB 00 ATEX 2049 X / RU C-DE.AA87.B.00394 proximity switches produced by Pepperl & Fuchs Type 2
(Limit1: +51 / -52)	
(Limit2: +41 / -42)	

**Special conditions**

- Only devices that are suited for operation in hazardous areas of Zone 2 and the conditions prevailing at the place of use may be connected to circuits in Zone 2 (manufacturer's declaration or certificate from the test center).
- Power supply for the 'Mechanical digital feedback with Pepperl & Fuchs SJ2-SN proximity switches' circuit must be provided intrinsically safe and in accordance with PTB 00 ATEX 2049 X / RU C-DE.AA87.B.00394 certificate according to application type 2.
- It is only permissible to connect, disconnect, and switch live circuits during installation or maintenance, or for the purpose of carrying out repairs.

**Note**

It is considered very unlikely that a potentially hazardous atmosphere would be present in Zone 2 at the same time that installation or maintenance or repair work was being carried out.

- Only non-flammable gases must be used for pneumatic power supply.
- Only cable entries may be used that suit the requirements of EN 60079-7 or EN 60079-15.

## Ordering Information

### Main ordering information TZIDC-110

Base model	V18346	XX	X	X	X	X	X	XX	X
TZIDC-110 Electro-Pneumatic Positioner, for PROFIBUS PA, intelligent, configurable, with indicator and operator panel									
<b>Case / Mounting</b>									
Case made of aluminium, varnished, for mounting to linear actuators acc. DIN / IEC 534 / NAMUR or to rotary actuators acc. VDI / VDE 3845		10							
Case made of aluminium, varnished, with mechanical position indicator, for mounting to linear actuators acc. DIN / IEC 534 / NAMUR or to rotary actuators acc. VDI / VDE 3845		20							
Case made of aluminium, varnished, for integral mounting to control valves (see dimensional drawing)		30							
Case made of aluminium, varnished, with mechanical position indicator, for integral mounting to control valves (see dimensional drawing)		40							
Case made of aluminium, varnished, for mounting to rotary actuators acc. VDI / VDE 3845 with extended rotation angle up to 270°		50							
Case made of aluminium, varnished, with mechanical position indicator, for mounting to rotary actuators acc. VDI / VDE 3845 with extended rotation angle up to 270°		60							
<b>Input / Communication Port</b>									
PROFIBUS PA							3		
<b>Explosion Protection</b>									
Without									0
ATEX II 2 G Ex ia IIC T6 resp. T4 Gb									1
cFMus									2
ATEX II 3 G Ex nA IIC T6 resp. T4 Gc									4
IECEx ia IIC T6 resp. T4 Gb									5
IECEx Ex nA IIC T6 resp. T4 Gc									6
UKEX Ex ia									A
UKEX Ex ib									B
ATEX II 3G Ex ec IIC T6, T4...T1 Gc									G
IECEx ic IIC T6 resp. T4 Gc									H
NEPSI Ex ia IIC T4/T6 Gb									U
NEPSI Ex ib IIC T4/T6 Gb									V
INMETRO Ex ia IIC T6...T4 Gb/Ex ib IIC T6 T4 Gb									P
KOSHA Ex ib									R
<b>Output / Safe Position (in case of an electrical power failure)</b>									
Single acting, fail safe									1
Single acting, fail freeze									2
Double acting, fail safe									4
Double acting, fail freeze									5

Continued see next page

<b>TZIDC-110 Electro-Pneumatic Positioner, for PROFIBUS PA</b>	<b>X</b>	<b>X</b>	<b>XX</b>	<b>X</b>
<b>Connections</b>				
Cable: Thread 1/2-14 NPT, air pipe: Thread 1/4-18 NPT	2			
Cable: Thread M20 x 1.5, air pipe: Thread 1/4-18 NPT	5 <sup>1)</sup>			
Cable: Thread M20 x 1.5, air pipe: Thread G 1/4	6 <sup>1)</sup>			
Cable: Thread G 1/2, air pipe: Thread Rc 1/4	7 <sup>1)</sup>			
<b>Optional Mechanical Kit for Digital Position Feedback</b>				
Without		0		
<b>Optional Mechanical Kit for Digital Position Feedback</b>				
Without			00	
Mechanical kit for digital position feedback with proximity switches S32-SN (NC or logical 1)			10 <sup>2)</sup>	
Mechanical kit for digital position feedback with 24 V AC / DC microswitches (change-over contacts)			50 <sup>3)</sup>	
<b>Design (Varnish / Coding)</b>				
Standard				1
Higher Stiffness + Lower Air Capacity				H
Increased Corrosion Protection incl. Protection Class IP 66				S

1) Not available with **Explosion Protection code 2 – cFMus**

2) Only for model with mechanical position indicator

3) Not for explosion protected version and only for model with mechanical position indicator

Continued see next page

## ... Ordering Information

### ... Main ordering information TZIDC-110

#### Additional ordering information TZIDC-110

Additional ordering information	XXX	XX	XXX	XXX	XXX	XXX	XXX	XXX	XXX	XXX
<b>Ex protection concept</b>										
IS Cl I,II,III Div.1/NI Cl I,II,III Div.2	PNI <sup>4)</sup>									
IS Cl I Div.1 (No NI)	PSI <sup>4)</sup>									
<b>Documentation Language</b>										
German		M1								
Italian		M2								
Spanish		M3								
French		M4								
English		M5								
Swedish		M7								
Finnish		M8								
Polish		M9								
Portuguese		MA								
Russian		MB								
Czech		MC								
Dutch		MD								
Danish		MF								
Greek		MG								
Latvian		MH								
Hungarian		ML								
Estonian		MM								
Bulgarian		MO								
Romanian		MP								
Slovak		MR								
Lithuanian		MS								
Slovenian		MU								
German		MV								
<b>Certificate of Compliance</b>										
Certificate of compliance with the order acc. EN 10204-2.1 (DIN 50049-2.1) with item description									CF2	
Test report 2.2 acc. EN 10204 (DIN 50049-2.2)									CF3	
<b>Inspection Certificate</b>										
Inspection certificate 3.1 acc. EN 10204									CBA	
<b>Marine approval</b>										
Marine approval DNV_GL									CM1	
<b>CCC Certification</b>										
3CC for Ex i & CCC for Ex d									CCC <sup>5)</sup>	
<b>Handling of Certificates</b>										
Send via e-mail									GHE	
Send via mail									GHP	
Send via mail express									GHD	
Send with instrument									GHA	
Only archived									GHS	
<b>UKCA Certification</b>										
UKCA									CU1	
<b>Certificate preparation</b>										
per device										GPD
per salesorder item										GPP
<b>Device Identification Label</b>										
Stainless steel 18.5 x 65 mm (0.73 x 2.56 in.)										MK1 <sup>6)</sup>
Sticker 11 x 25 mm (0.43 x 0.98 in.)										MK3

4) Only available with **Explosion Protection code 2 – cFMus**

5) Only available with **Explosion Protection code U, V – NEPSI**

6) Plain text, max. 16 letters

## Accessories

Designation	Order no.
<b>Mounting bracket</b>	
EDP300/TZIDC attachment bracket for 90° rotary actuators, mounted in accordance with VDI/VDE 3845, bracket dimensions A/B 80/20 mm (aluminum housing)	319603
EDP300/TZIDC attachment bracket for 90° rotary actuators, mounted in accordance with VDI/VDE 3845, bracket dimensions A/B 80/30 mm (aluminum housing)	319604
EDP300/TZIDC attachment bracket for 90° rotary actuators, mounted in accordance with VDI/VDE 3845, bracket dimensions A/B 130/30 mm (aluminum housing)	319605
EDP300/TZIDC attachment bracket for 90° rotary actuators, mounted in accordance with VDI/VDE 3845, bracket dimensions A/B 130/50 mm (aluminum housing)	319606
<b>Attachment kit</b>	
EDP300/TZIDC attachment kit Uhde Type 4 stroke 400 mm cranked	7959500
<b>Mounting kit for linear actuators</b>	
EDP300/TZIDC attachment kit for linear actuators, stroke adjustment 10 to 35 mm	7959125
EDP300/TZIDC attachment kit for linear actuators, stroke adjustment 20 to 100 mm	7959126
<b>Lever</b>	
EDP300/TZIDC lever 30 mm	7959151
EDP300/TZIDC lever 100 mm	7959152
<b>Adapter</b>	
EDP300/TZIDC adapter (axle connector) for part-turn actuators to VDI/VDE 3845	7959110
EDP300/TZIDC keyed shaft adapter	7959371
<b>Pressure gauge block</b>	
TZIDC pressure gauge block, single acting, graphite black, 2 pressure gauges 28 mm, piping connections G ¼ in, 1 x 0 to 10 bar/0 to 140 psi for supply air pressure, 1 x 0 to 10 bar/0 to 140 psi for output pressure, including attachment material	7959112
TZIDC pressure gauge block, 0.6 MPa, single acting, G ¼ in thread	7959364
TZIDC pressure gauge block, 0.6 MPa, single acting, Rc ¼ in thread	7959358
TZIDC pressure gauge block, 0.6 MPa, single acting, ¼ in NPT thread	7959360
TZIDC pressure gauge block, single acting, graphite black, 2 pressure gauges 28 mm, piping connections ¼ in NPT, 1 x 0 to 10 bar/0 to 140 psi for supply air pressure, 1 x 0 to 10 bar/0 to 140 psi for output pressure, including attachment material	7959114
TZIDC pressure gauge block, double acting, graphite black, 3 pressure gauges 28 mm, piping connections G ¼ in, 1 x 0 to 10 bar/0 to 145 psi for supply air pressure, 2 x 0 to 10 bar/0 to 145 psi for output pressure, including attachment material	7959116
TZIDC pressure gauge block, 0.6 MPa, double acting, G ¼ in thread	7959365
TZIDC pressure gauge block, 0.6 MPa, double acting, Rc ¼ in thread	7959359
TZIDC pressure gauge block, 0.6 MPa, double acting, ¼ in NPT thread	7959361
TZIDC pressure gauge block, double acting, graphite black, 3 pressure gauges 28 mm, piping connections ¼ in NPT, 1 x 0 to 10 bar/0 to 140 psi for supply air pressure, 2 x 0 to 10 bar/0 to 140 psi for output pressure, including attachment material	7959118
TZIDC pressure gauge block, double acting, black, 3 pressure gauges VA 28 mm, piping connections ¼ in NPT, 1 x 0 to 10 bar/0 to 140 psi for supply air pressure, 2 x 0 to 10 bar/0 to 140 psi for output pressure, including attachment material	7959185
TZIDC brass filter regulator, connections thread G ¼, including attachment material to the pressure gauge block	7959119
TZIDC brass filter regulator, connections thread ¼-18 NPT, including attachment material to the pressure gauge block	7959120
TZIDC pressure gauge block, black, 2 pressure gauges VA 28 mm, piping connections G ¼ in, 1 x 0 to 10 bar/0 to 140 psi for supply air pressure, 1 x 0 to 10 bar/0 to 140 psi for output pressure, including attachment material	7959179
TZIDC pressure gauge block, double acting, black, 2 pressure gauges VA 28 mm, piping connections G ¼ in, 1 x 0 to 10 bar/0 to 140 psi for supply air pressure, 2 x 0 to 10 bar/0 to 140 psi for output pressure, including attachment material	7959183

## ... Ordering Information

### ... Accessories

Designation	Order no.
<b>Cable glands/screw plugs</b>	
TEIP11-PS/EDP300/TZIDC cable gland NPT1/2" plastic, non-Ex (available Q2-Q3 2023)	3KXE001070U0100
TEIP11-PS/EDP300/TZIDC cable gland M20x1.5 plastic, non-Ex (available Q2-Q3 2023)	3KXE001071U0100
TEIP11-PS/EDP300/TZIDC cable gland M20x1.5 EMC, brass, nickel-plated for Ex eb IIC Gb, Ex ta IIIC Da, Ex i (IP 68) ambient temperature -20 °C to 95 °C (available Q2-Q3 2023)	3KXE001072U0100
TEIP11-PS/EDP300/TZIDC cable gland NPT1/2" EMC, brass, nickel-plated for Ex eb IIC Gb, Ex ta IIIC Da, Ex i (IP 68) ambient temperature -20 °C to 95 °C (available Q2-Q3 2023)	3KXE001073U0100
TEIP11-PS/EDP300/TZIDC cable gland M20x1.5 INOX, stainless steel for Ex db IIC Gb, Ex ta IIIC Da, Ex i (IP 68) ambient temperature -60 °C to 105 °C (available Q2-Q3 2023)	3KXE001074U0100
TEIP11-PS/EDP300/TZID cable gland NPT1/2" INOX, stainless steel for Ex db IIC Gb, Ex ta IIIC Da, Ex i (IP 68) ambient temperature -60 °C to 105 °C (available Q2-Q3 2023)	3KXE001075U0100
TEIP11-PS/EDP300/TZIDC cable gland PG11, brass, nickel-plated for Ex eb IIC Gb, Ex ta IIIC Da, Ex i (IP 68) ambient temperature -60 °C to 95 °C (available Q2-Q3 2023)	3KXE001076U0100
TEIP11-PS/EDP300/TZIDC screw plug M20x1.5 black plastic for Ex eb IIC Gb, Ex tb IIIC Db, Ex i (IP 66) ambient temperature -55 °C to 95 °C (available Q2-Q3 2023)	3KXE001077U0100
TEIP11-PS/EDP300/TZIDC screw plug M20x1.5 INOX, stainless steel for Ex db eb IIC Gb, Ex ta IIIC Da, Ex i (IP 68) ambient temperature -60 °C to 180 °C (available Q2-Q3 2023)	3KXE001078U0100
<b>Mounting kit</b>	
EDP300/TZIDC mounting kit for Fisher 1051-30, 1052-30	7959214
EDP300/TZIDC mounting kit for Fisher 1061 Size 130	7959206
EDP300/TZIDC mounting kit for Fisher 471	7959195
EDP300/TZIDC attachment kit for Fisher 657/667 Size 10 ... 90 mm	7959177
EDP300/TZIDC mounting kit for Fisher Gulde 32/34	7959344
EDP300/TZIDC mounting kit for Gulde DK	7959161
EDP300/TZIDC attachment kit for Keystone 79U/E-002(S) ... 79U/E-181(S)	7959147
EDP300/TZIDC mounting kit for Masoneilan CAMFLEX II, VARIMAX, MINITORK II	7959144
EDP300/TZIDC mounting kit for Masoneilan VariPak 28000 Series	7959163
EDP300/TZIDC mounting kit for MaxFlo MaxFlo	7959140
EDP300/TZIDC mounting kit for NAF 791290	7959207
EDP300/TZIDC attachment kit for NAMUR stroke 100 to 170 mm	7959339
EDP300/TZIDC mounting kit for NELES BC6-20, B1C6-20, B38-20, B1J8-20	7959146
EDP300/TZIDC attachment kit, lever for linear actuators, length 150 to 250 mm	7959210
TZIDC attachment kit, for Nuovo Pignone valves, pressure gauge block with 2 pressure gauges, material stainless steel, single acting ¼ in NPT, 0 to 10 bar	7959181
EDP300/TZIDC mounting kit for Samson 241, 271, 3271	7959145
EDP300/TZIDC mounting kit for Samson 3277	7959136
EDP300/TZIDC mounting kit for Schubert&Salzer GS 8020/8021/8023	7959200
EDP300/TZIDC attachment kit for SED stroke 100 mm	7959141
EDP300/TZIDC attachment kit to control device for remote position sensor (for wall and pipe mounting)	7959381
TZIDC attachment kit TZIDC-200 lever 30 mm	7959262
TZIDC accessory Kent Introl 170 mm	7959376
TZIDC accessory Kent Introl 250 mm	7959377



## Trademarks

PROFIBUS and PROFIBUS PA are registered trademarks of PROFIBUS & PROFINET International (PI)

Sales



Service



---

## **ABB Measurement & Analytics**

For your local ABB contact, visit:  
**[www.abb.com/contacts](http://www.abb.com/contacts)**

For more product information, visit:  
**[www.abb.com/positioners](http://www.abb.com/positioners)**

---

We reserve the right to make technical changes or modify the contents of this document without prior notice. With regard to purchase orders, the agreed particulars shall prevail. ABB does not accept any responsibility whatsoever for potential errors or possible lack of information in this document.

We reserve all rights in this document and in the subject matter and illustrations contained therein. Any reproduction, disclosure to third parties or utilization of its contents – in whole or in parts – is forbidden without prior written consent of ABB.