

JUMO IMAGO F3000

Process controller
for the meat processing
industry

B 70.0101.0 Operating Instructions

for equipment manufacturers

contents

1	Introduction	5
1.1	Preface	5
1.2	Arrangement of the documentation	5
1.3	Typographical conventions	6
1.3.1	Warning signs	6
1.3.2	Note signs	6
1.3.3	Representation	7
2	Identifying the instrument version	9
2.1	Type designation	9
2.2	Delivery package	10
2.3	Accessories	10
2.3.1	Hardware/software requirements for the setup program	10
2.4	Plug-in boards for expansion/retrofitting	10
3	Installation	11
3.1	Dimensions	11
3.2	Mounting	12
4	Electrical Connection	13
4.1	Installation notes	13
4.2	Connection diagram	14
4.2.1	I/O module (slot 1)	15
4.2.2	I/O module (slot 2)	15
4.2.3	Logic module (slot 3)	16
4.2.4	Universal interface (slot 3)	16
4.2.5	Relay module (slot 4)	17
4.2.6	Relay module (slot 5)	17
4.2.7	Logic module (slot 6)	17
4.2.8	Relay module (slot 6)	18
4.2.9	Connector 13	18
4.2.10	Connector 14	18
4.2.11	Connector 15	19
4.2.12	Connector 16	19
4.3	Electrical isolation	19
5	Instrument Description	21
5.1	Display and control elements	21
5.1.1	Color screen	23
5.1.2	Keypad for numerical and text entry	24
5.1.3	Freely assignable function keys	24
5.1.4	LED displays	25
5.1.5	Start/End key	25
5.2	Operating summary	26

contents

6	Operation	27
6.1	Basic status	27
6.2	Program design	28
6.2.1	General	28
6.2.2	Program entry	29
6.3	Start program	36
6.3.1	Special function: Quick Start	37
6.4	Automatic operation	38
6.4.1	Pause program	38
6.4.2	Temporary alterations	39
6.5	Manual operation	40
6.5.1	Start of self-optimization at the parameter level	41
6.6	Stop program	42
6.7	Program end signal	42
6.8	Acknowledging alarms	42
6.9	General	43
6.10	MENU configuration	43
6.10.1	Setup interface	43
6.10.2	Fieldbus interface	43
6.10.3	Analog inputs	44
6.10.4	Controller	44
6.10.5	Core probe	44
6.10.6	Program source	44
6.10.7	Process step editor	45
6.10.8	Temperature unit	45
6.10.9	Password (config)	45
6.11	MENU parameterization	46
6.11.1	Controller parameter sets	46
6.11.2	Limit comparators	46
6.11.3	Smoke generator	46
6.11.4	Self-optimization	46
6.11.5	Password (parameter)	46
6.12	User data	46
6.12.1	Contrast	47
6.12.2	Display	47
6.12.3	Instrument data	47
6.13	MENU counter	47
6.14	MENU device access	47
6.15	Plug & Play (P&P)	48
6.15.1	Write data to P&P memory	50
6.15.2	Activate automatic save	50
6.15.3	Activate/de-activate write protection	51
6.15.4	Copying programs	53
6.15.5	Replacing a faulty device	54

6.15.6	Retrofitting a P&P memory	55
6.15.7	Making a backup copy	55
6.15.8	Commissioning a new instrument	55
6.15.9	P&P memory, programming by OEM	55
6.15.10	Loading data for a write-protected P&P memory on site	55
6.15.11	Load new instrument software	56
6.16	Instrument-only settings	57
7	Setup Program	59
7.1	Selectors	60
7.2	Process steps	62
7.2.1	List of the process steps	62
7.2.2	Editing process steps	63
7.3	Screen representation	65
7.4	Configuration	65
7.4.1	Interfaces	65
7.4.2	Special settings in interface operation with mTRON modules	66
7.4.3	Analog inputs	67
7.4.4	Controller	68
7.4.5	Core changeover	70
7.4.6	Program source	71
7.5	Parameterization	73
7.5.1	Controller parameters	73
7.5.2	Limit comparators	74
7.5.3	Smoke generator	76
7.6	User data	77
7.6.1	Screen saver	77
7.6.2	Instrument data	77
7.7	Setup-only settings	78
7.7.1	7-segment displays	78
7.7.2	Function keys	78
7.7.3	Texts	80
7.7.4	Names	80
7.7.5	Analog outputs	80
7.7.6	Assignment of the relay outputs	81
7.7.7	Logic and alarm functions	82
7.7.8	Fan control	85
7.7.9	Math/logic	86
7.7.10	Software locks	90
7.7.11	Operating hours counter	91
7.7.12	Production data	91
7.7.13	Logic delay	91
7.7.14	Recording	92
7.7.15	Foreign languages	92
7.8	Setup data info	92

1.1 Preface

Version

These instructions are valid for the software version: 152.02.02

The version can be called up under MENU → Configuration → User data → Instrument data

Warranty



If any difficulties should arise during commissioning, please do not make any unauthorized manipulations to the instrument. This could endanger your rights under the instrument warranty. In such a case, please contact your local representative or the main factory.

Technical data

Technical data can be found on the Internet at: www.jumo.net

Products → Electronic controllers → Programmers → JUMO Imago F3000

Electrostatic discharge



When returning instrument modules, assemblies or components, the rules of EN 100 015 “Protection of electrostatically sensitive components” must be observed. Use only the appropriate **ESD** packaging for transport. Please note that we cannot accept any liability for damage caused by ESD (electrostatic discharge).

1.2 Arrangement of the documentation

Operating Instructions B 70.0101

These operating instructions are addressed to equipment manufacturers (OEMs) who have had appropriate professional training. In addition to installation and electrical connection, they also include all the information required for commissioning the instrument and setting its parameters.



Please read these operating instructions before commissioning the equipment. Keep the operating instructions in a place that is accessible to all users at all times.

Please help us to improve these instructions where necessary.

Phone: +49 661 6003 - 0

Fax: +49 661 6003 - 607

Expanding / retrofitting B 70.0101.5.1

These instructions will be included in the package if accessory modules are ordered at a later date.

They contain information on installing the modules and safety procedures for internal operations within the equipment.

1 Introduction

1.3 Typographical conventions

1.3.1 Warning signs

Danger



This sign is used where there may be **danger to personnel** if the instructions are ignored or not followed correctly!

Caution



This sign is used where there may be **damage to equipment or data** if the instructions are ignored or not followed correctly!

ESD



This sign is used where precautionary measures must be taken for handling **electrostatically sensitive components**.

1.3.2 Note signs

Note



This sign is used where your **special attention** is drawn to a comment.

Reference



This sign refers to **additional information** in other manuals, chapters or sections.

Footnote

abc¹

Footnotes are remarks that **refer to specific points** in the text. Footnotes consist of two parts:
A marker in the text, and the footnote text itself.
The markers in the text are arranged as continuous superscript numbers.

Instructions for action

*

This sign marks the description of a **required action**. The individual steps are indicated by this asterisk, e.g.

* Insert the instrument into the panel cut-out from the front.

1.3.3 Representation

Softkeys and their operation



Keys are shown as they appear on the color screen in the bottom line. They are labeled by symbols or texts.

If a key has a multiple function, then the text used it that which corresponds to the **function at the moment**.

Menu items

File → *save as*

Small arrows between the words indicate a **sequence of commands** to be performed one after another.

1 Introduction

2 Identifying the instrument version

2.1 Type designation

The nameplate is glued onto the housing. The type designation that is printed on it must correspond to the text of the order.

	(1) Basic version	700101 JUMO IMAGO F3000
	(2) Basic type extension	
	Format	
x	1	315 mm x 171 mm, portrait format
x	2	171 mm x 315 mm, landscape format
	Version	
x	8	Standard, with factory settings
x	9	Customized programming according to specification
	Language for the configuration level	
x	1	German
x	2	English
x	3	French
x	5	Russian
	(3) Slot assignments	
	Code	Plug-in boards for inputs, outputs, interfaces
	0	not used
	1	Relay module: 10 relay outputs (8 make contacts, 2 changeover)
	2	Input module: 4 analog inputs, 5 logic inputs for floating contacts
	3	I/O module: 4 analog inputs, 5 logic inputs for floating contacts, 2 analog outputs
	4	Logic module: 11 logic inputs for floating contacts, 5 relay outputs (make)
	5	Universal interface: MODbus (electrically isolated)
	6	Universal interface: Profibus-DP (electrically isolated)
	7	Input module: 4 analog inputs, 5 logic inputs for PLC signal levels
	8	I/O module: 4 analog inputs, 5 logic inputs for PLC signal levels, 2 analog outputs
	9	Logic module: 11 logic inputs for PLC signal levels, 5 relay outputs (make)
		Slot number
		1 2 3 4 5 6
	0	- X X - X X
	1	- - - X X X
	2	X X - - - -
	3	X X - - - -
	4	- - X - - X
	5	- - X - - -
	6	- - X - - -
	7	X X - - - -
	8	X X - - - -
	9	- - X - - -
		- cannot be assigned X can be assigned ■ standard assignment
	(4) Supply	
x	23	110 – 240V AC -15/+10%, 48 – 63Hz
x	25	20 – 30V AC/DC, 48 – 63Hz
	(5) Interface for teleservice and visualization	
x	00	no interface
x	54	Interface RS422/485 (MODbus slave, connector 13)
	(6) Extra codes	
x	000	no extra code
x	211	Plug & Play memory
x	213	Recording function
	(7) Approvals	
x	000	none
x	061	Underwriters Laboratories Inc. (UL)

Order code (1) (2) (3) (4) (5) (6) (7)

Order example 700101 / 181 - 200110 - 23 - 00 , 000 - 000

2 Identifying the instrument version

2.2 Delivery package

- Operating Instructions B 70.0101 for the equipment manufacturer
- Operating Instructions B 70.0101.1 for the user
- 4 mounting brackets

2.3 Accessories

Product designation	Sales No.
Setup program with program editor for Windows 95/98/NT4.0 / 2000 / ME / XP	70/00398296
Setup program with program editor and teleservice for Windows 95/98/NT4.0 / 2000 / ME / XP	70/00398297
Program editor for Windows 95/98/NT4.0 / 2000 / ME / XP	70/00398294
Interface converter, RS232 to RS422	70/00376969
Plug-in power supply for interface converter	70/00365933
PC interface cable for setup program, to connect the instrument to a PC, length 2 m	70/00301315
Plug & Play memory	70/00398298
Enable recording function	70/00433789
PC Evaluation software (PCA3000)	70/00431882
PCA Communication software (PCC)	70/00431879

2.3.1 Hardware/software requirements for the setup program

- PC Pentium 100 (or better)
- 32 Mbyte RAM
- 15 Mbyte free space on the hard disk
- CD-ROM drive
- 1 free COM interface
- Microsoft Windows® 95/98/NT4.0/2000/ME

2.4 Plug-in boards for expansion/retrofitting

Plug-in boards for expansion/retrofitting	Sales No.
Relay module: 10 relay outputs (8 make, 2 changeover)	70/00398349
Input module: 4 analog inputs, 5 logic inputs	70/00398351
I/O module: 4 analog inputs, 5 logic inputs, 2 analog outputs	70/00398352
Logic module: 11 logic inputs, 5 relay outputs (make contacts)	70/00398350
Interface for teleservice and visualization, RS422/485 (Connector 13, MODbus slave, "Code 54")	70/00398353
Input module for PLC level	70/00433065
Logic module for PLC level	70/00433064
Delivery time approx. 2 weeks:	
Universal interface MODbus (Slot 3)	70/00411250
Universal interface PROFIBUS-DP (Slot 3)	70/00411248

3.1 Dimensions

Portrait format

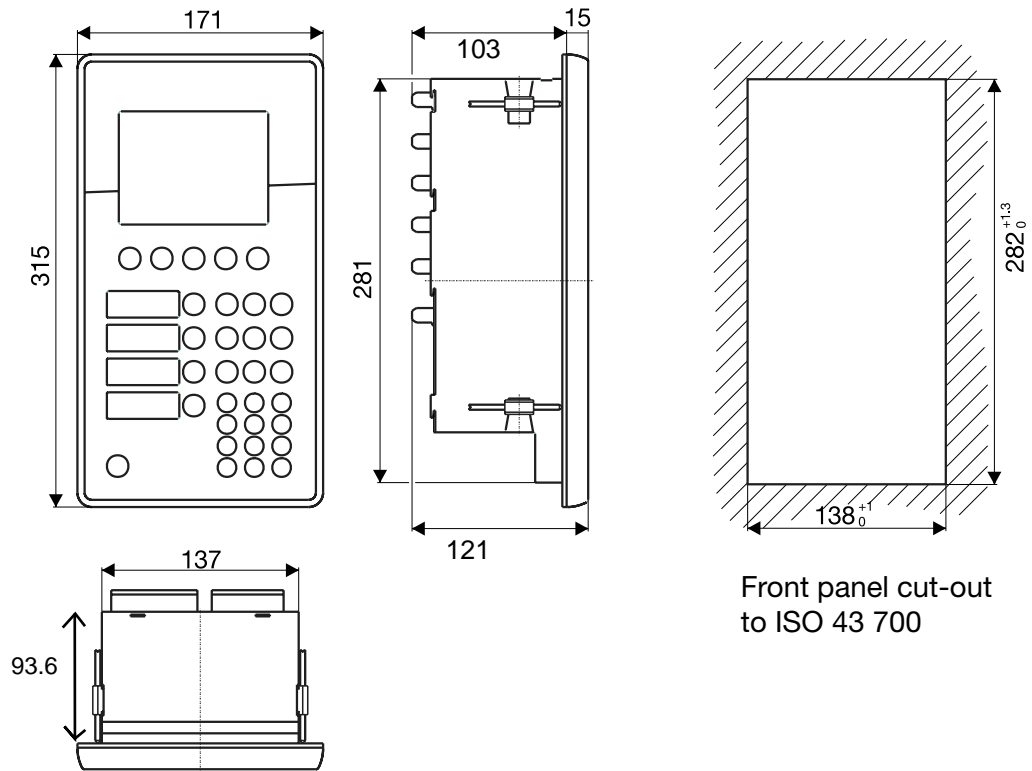

Landscape format

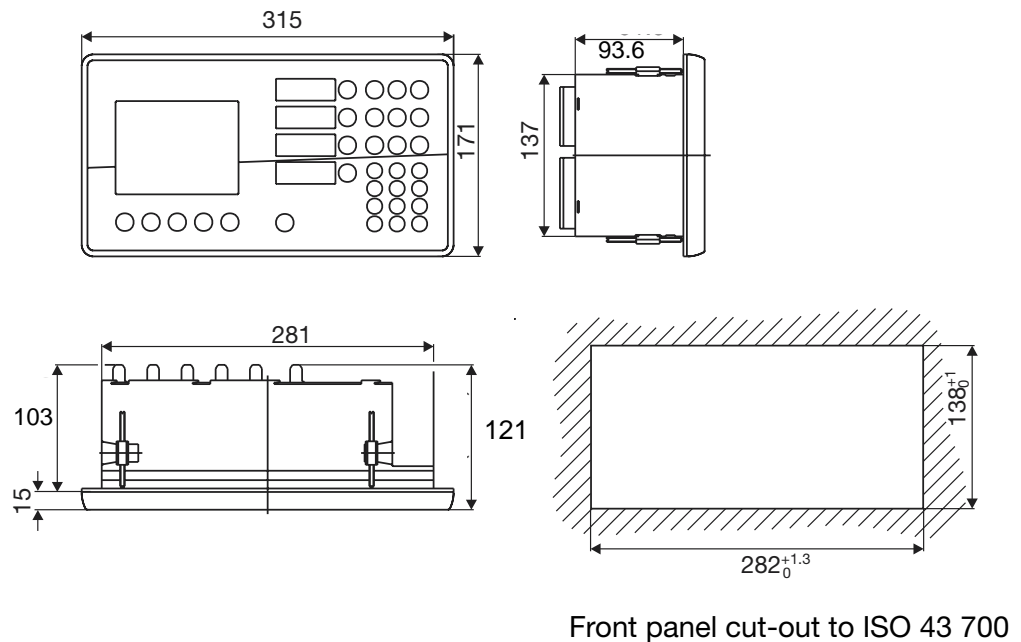

3 Installation

3.2 Mounting

Front panel cut-out

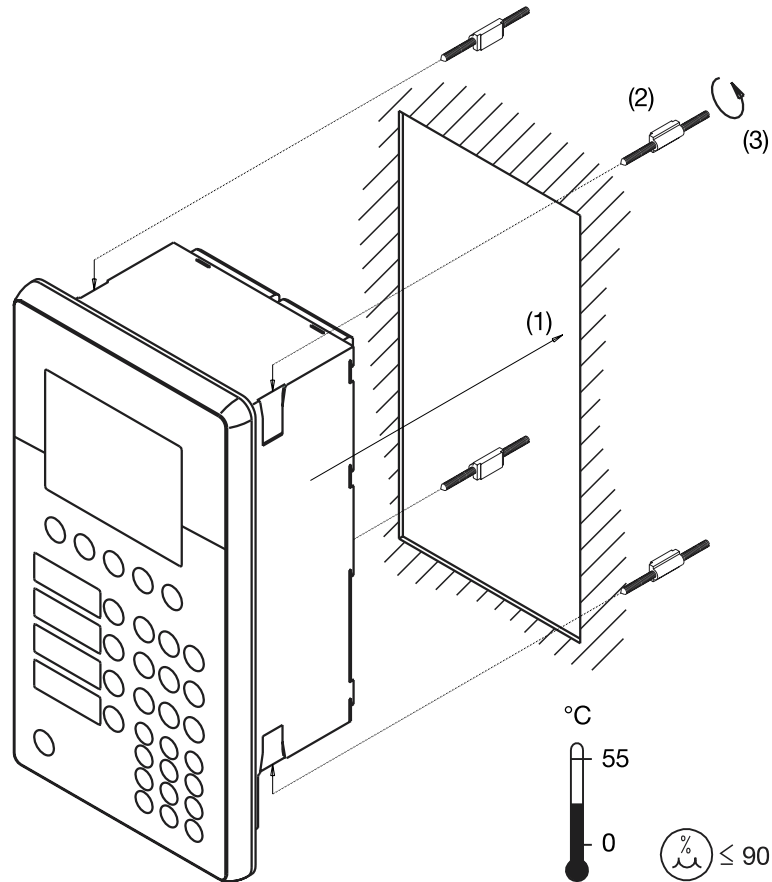

- * (1) Insert the instrument from the front into the front panel cut-out
- * (2) From the back of the panel, push the mounting brackets into the guide slots on the sides of the housing
- * (3) Use a screwdriver to tighten up the mounting brackets evenly

Close mounting

If several instruments are mounted in the same front panel, either above one another or side-by-side, then a minimum spacing of 35 mm must be allowed between each cut-out in the panel.

Care of the front panel

The front panel can be cleaned with normal commercial detergents and cleaning agents. It is resistant to organic solvents (such as ethyl alcohol, turpentine substitute, P1, xylol and the like).



It is **not** resistant to corrosive acids or lyes, abrasives, or cleaning with high-pressure cleaners!

4.1 Installation notes



- The choice of cable material, the installation and the electrical connections to the equipment must meet the requirements of VDE 0100 “Regulations on the Installation of Power Circuits with Nominal Voltages below 1000V”, or the appropriate local regulations.
 - Work inside the equipment must only be carried out to the extent described and, like the electrical connections, must only be performed by qualified personnel. The replacement of internal fuses is not envisaged. If a defect occurs, the device must be repaired by the manufacturer.
 - If it is possible to make bodily contact with live parts while working on the equipment, it must be completely (2-pole) isolated from the supply (for instance, through a separate supply switch).
 - The electromagnetic compatibility (EMC) conforms to the standards and regulations cited under Technical Data.
⇒ Data Sheet T 70.0101
 - All input and output cables which are not connected to the supply network must be implemented as twisted and shielded cables. The shield must be grounded at one end.
 - As far as possible, do not run input and output cabling close to current-carrying components or cables, but route them separately and not parallel to such cables.
 - Inductive loads in the vicinity of the equipment, such as contactors or solenoid valves, should be fitted with RC modules for interference suppression.
 - Earth the equipment to the protective earth at the PE terminal. The earthing cable must have the same conductor cross-section as the power supply cables.
 - Earth/ground cables must be routed in a star configuration to a common earthing point that is connected to the protective earth of the supply installation.
Earth cables must not be looped (“daisy-chained”), i.e. they must not be routed through one piece of equipment after another.
 - Do not connect any additional loads to the supply terminals of the equipment.
 - Since the device only has limited short-circuit protection, an additional external fuse rated for 800 mA, slow-blow, must be wired in close proximity to the device.
 - The equipment is not suitable for installation in **Ex** areas (areas with an explosion hazard). It must be mounted in a fire-protective electrical housing.
-

4 Electrical Connection

4.2 Connection diagram

The electrical connections must only be made by qualified personnel.

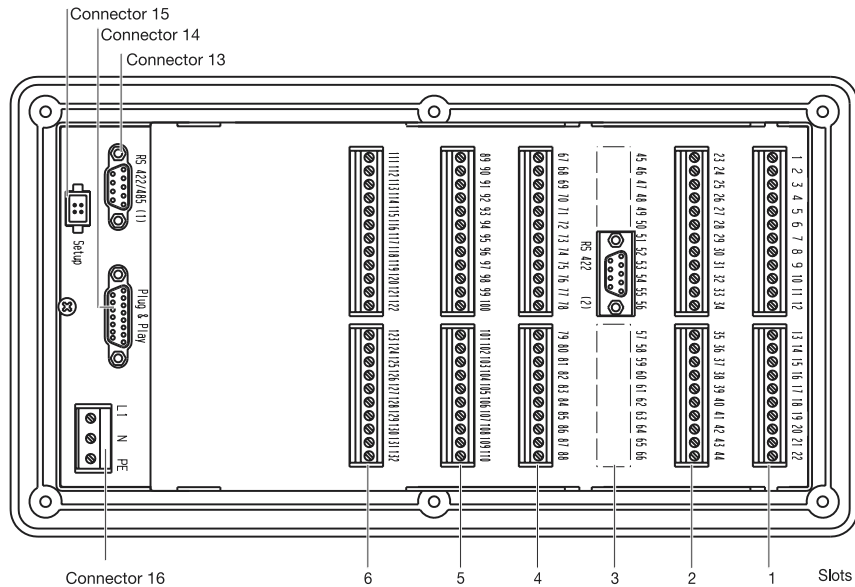

Note: the link positions must be altered for voltage or thermocouple inputs!

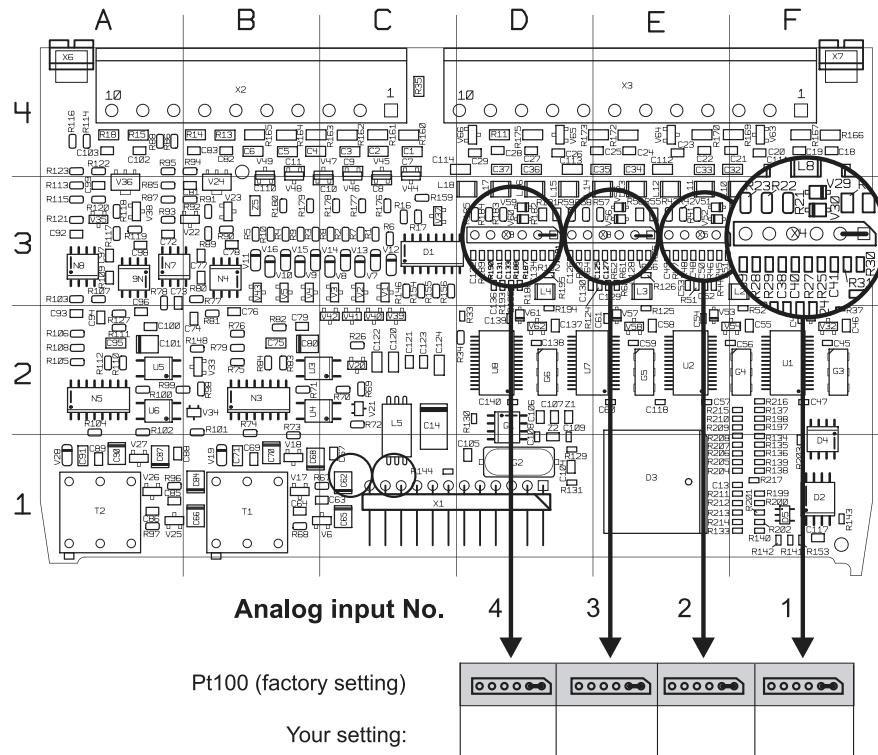





Setting options:
Only **one** link to be plugged in for each anaog input !

	Pt100
	0 — 10V
	0 — 1V and thermocouple

The current signal measurement does not depend on the position of the link !

4 Electrical Connection

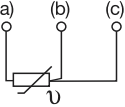

4.2.1 I/O module (slot 1)

	Analog input No.	1	2	3	4	Symbol
	Thermocouple	1 + 3 -	4 + 6 -	7 + 9 -	10 + 12 -	
	Resistance thermometer	1 (a) 2 (b) 3 (c)	4 (a) 5 (b) 6 (c)	7 (a) 8 (b) 9 (c)	10 (a) 11 (b) 12 (c)	
	Current input 0(4) – 20mA	2 + 3 -	5 + 6 -	8 + 9 -	11 + 12 -	
	Voltage input 0(2) – 10V	1 + 3 -	4 + 6 -	7 + 9 -	10 + 12 -	

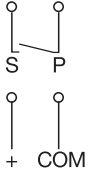



The analog inputs 1 and 2, 3 and 4, must be electrically isolated from one another!

	Logic input No.	1	2	3	4	5	Symbol
	Floating contact, or PLC input 24V DC LO level: 0 to 6V HI level: 13 to 30V	13 S 18 P	14 S 18 P	15 S 18 P	16 S 18 P	17 S 18 P	

If PLC inputs are used, then the supply voltage for the logic inputs must be electrically isolated from the analog inputs!

	Analog output No.	1	2	Symbol
	0(4) – 20mA 0(2) – 10V configurable	19 + 20 -	21 + 22 -	

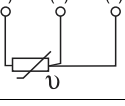
4.2.2 I/O module (slot 2)

	Analog input No.	5	6	7	8	Symbol
	Thermocouple	23 + 25 -	26 + 28 -	29 + 31 -	32 + 34 -	
	Resistance thermometer	23 (a) 24 (b) 25 (c)	26 (a) 27 (b) 28 (c)	29 (a) 30 (b) 31 (c)	32 (a) 33 (b) 34 (c)	
	Current input 0(4) – 20mA	24 + 25 -	27 + 28 -	30 + 31 -	33 + 34 -	
	Voltage input 0(2) – 10V	23 + 25 -	26 + 28 -	29 + 31 -	32 + 34 -	

The analog inputs 5 and 6, 7 and 8, must be electrically isolated from one another!

4 Electrical Connection

	Logic input No.	6	7	8	9	10	Symbol
	Floating contact, or PLC input: 24V DC LO level: 0 to 6V HI level: 13 to 30V	35 S 40 P	36 S 40 P	37 S 40 P	38 S 40 P	39 S 40 P	
		35 + 40 COM	36 + 40 COM	37 + 40 COM	38 + 40 COM	39 + 40 COM	
If PLC inputs are used, then the supply voltage for the logic inputs must be electrically isolated from the analog inputs!							
	Analog output No.	3			4		Symbol
	0(4) – 20mA 0(2) – 10V configurable	41 + 42 -			43 + 44 -		

4.2.3 Logic module (slot 3)

	Logic input No.	22	23	24	25	26	27	28	29	30	31	32	Symbol
	Floating contact, or PLC input: 24V DC LO level: 0 to 6V HI level: 13 to 30V	45 S 56 P	46 S 56 P	47 S 56 P	48 S 56 P	49 S 56 P	50 S 56 P	51 S 56 P	52 S 56 P	53 S 56 P	54 S 56 P	55 S 56 P	
		45 + 56 COM	46 + 56 COM	47 + 56 COM	48 + 56 COM	49 + 56 COM	50 + 56 COM	51 + 56 COM	52 + 56 COM	53 + 56 COM	54 + 56 COM	55 + 56 COM	
If PLC inputs are used, then the supply voltage for the logic inputs must be electrically isolated from the analog inputs!													
	Relay output No.	31		32		33		34		35		Symbol	
	3A 230V	57 P 58 S		59 P 60 S		61 P 62 S		63 P 64 S		65 P 66 S			

4.2.4 Universal interface (slot 3)

	Connection for	Assignment	PROFIBUS-DP	Symbol
	RS422 interface, electrically isolated	4 RxD (+)	8 A(+)	
		9 RxD (-)	3 B(-)	
		3 TxD (+)	6 VCC	
		8 TxD (-)	5 GND	
		5 GND	9 GND	

4 Electrical Connection

4.2.5 Relay module (slot 4)

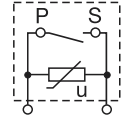
	Relay output No.	1	2	3	4	5	Symbol
	3A 230V	67 P 68 O 69 S	70 P 71 O 72 S	73 P 74 S	75 P 76 S	77 P 78 S	
Relay output No.	6	7	8	9	10	Symbol	
3A 230V	79 P 80 S	81 P 82 S	83 P 84 S	85 P 86 S	87 P 88 S		

4.2.6 Relay module (slot 5)

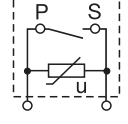
	Relay output No.	11	12	13	14	15	Symbol
	3A 230V	89 P 90 O 91 S	92 P 93 O 94 S	95 P 96 S	97 P 98 S	99 P 100 S	
Relay output No.	16	17	18	19	20	Symbol	
3A 230V	101 P 102 S	103 P 104 S	105 P 106 S	107 P 108 S	109 P 110 S		

4.2.7 Logic module (slot 6)

	Logic input No.	11	12	13	14	15	16	17	18	19	20	21	Symbol
	Floating contact, or PLC input: 24V DC LO level: 0 to 6V HI level: 13 to 30V	111 S 122 P	112 S 122 P	113 S 122 P	114 S 122 P	115 S 122 P	116 S 122 P	117 S 122 P	118 S 122 P	119 S 122 P	120 S 122 P	121 S 122 P	122 P
	111+ 122 COM	112+ 122 COM	113+ 122 COM	114+ 122 COM	115+ 122 COM	116+ 122 COM	117+ 122 COM	118+ 122 COM	119+ 122 COM	120+ 122 COM	121+ 122 COM	122 COM	

If PLC inputs are used, then the supply voltage for the logic inputs must be electrically isolated from the analog inputs!

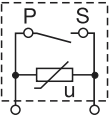

4 Electrical Connection

	Relay output No.	26	27	28	29	30	Symbol
	3A 230V	123 P 124 S	125 P 126 S	127 P 128 S	129 P 130 S	131 P 132 S	

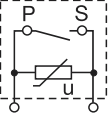
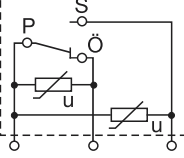
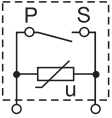
4.2.8 Relay module (slot 6)

	Relay output No.	21	22	23	24	25	Symbol
	3A 230V	111 P 112 O 113 S	114 P 115 O 116 S	117 P 118 S	119 P 120 S	121 P 122 S	 
	(This is not electrically isolated from the analog inputs, logic inputs, and the teleservice interface.) ⇒ Chapter 4.3 “Electrical isolation”						
	Relay output No.	26	27	28	29	30	Symbol
	3A 230V	123 P 124 S	125 P 126 S	127 P 128 S	129 P 130 S	131 P 132 S	

4.2.9 Connector 13

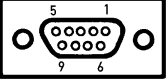

 	Teleservice, visualization	RS 422	RS 485	Symbol
	RS422/485 interface	4 RxD (+) 9 RxD (-) 3 TxD (+) 8 TxD (-) 5 GND	8 RxD/TxD B(-) 3 RxD/TxD A(+) 5 GND	

4.2.10 Connector 14

Connection for	Picture	Symbol
Plug & Play interface		

4 Electrical Connection

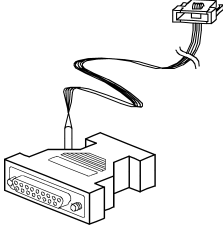
4.2.11 Connector 15

Connection for	Diagram	Symbol
Setup connector	PC interface with TTL/RS232 converter 	

4.2.12 Connector 16

Connection	Assignment	Symbol
Supply voltage, as per nameplate	L1 phase/line N neutral PE protective earth	

4.3 Electrical isolation

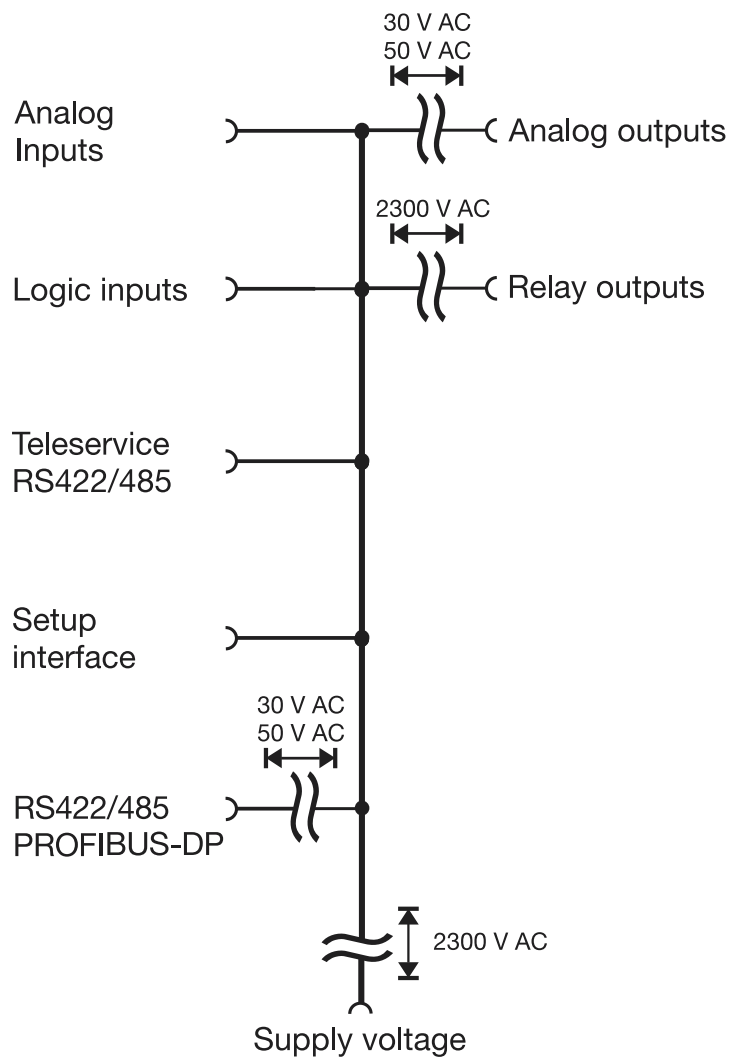

4 Electrical Connection

5.1 Display and control elements

Portrait format

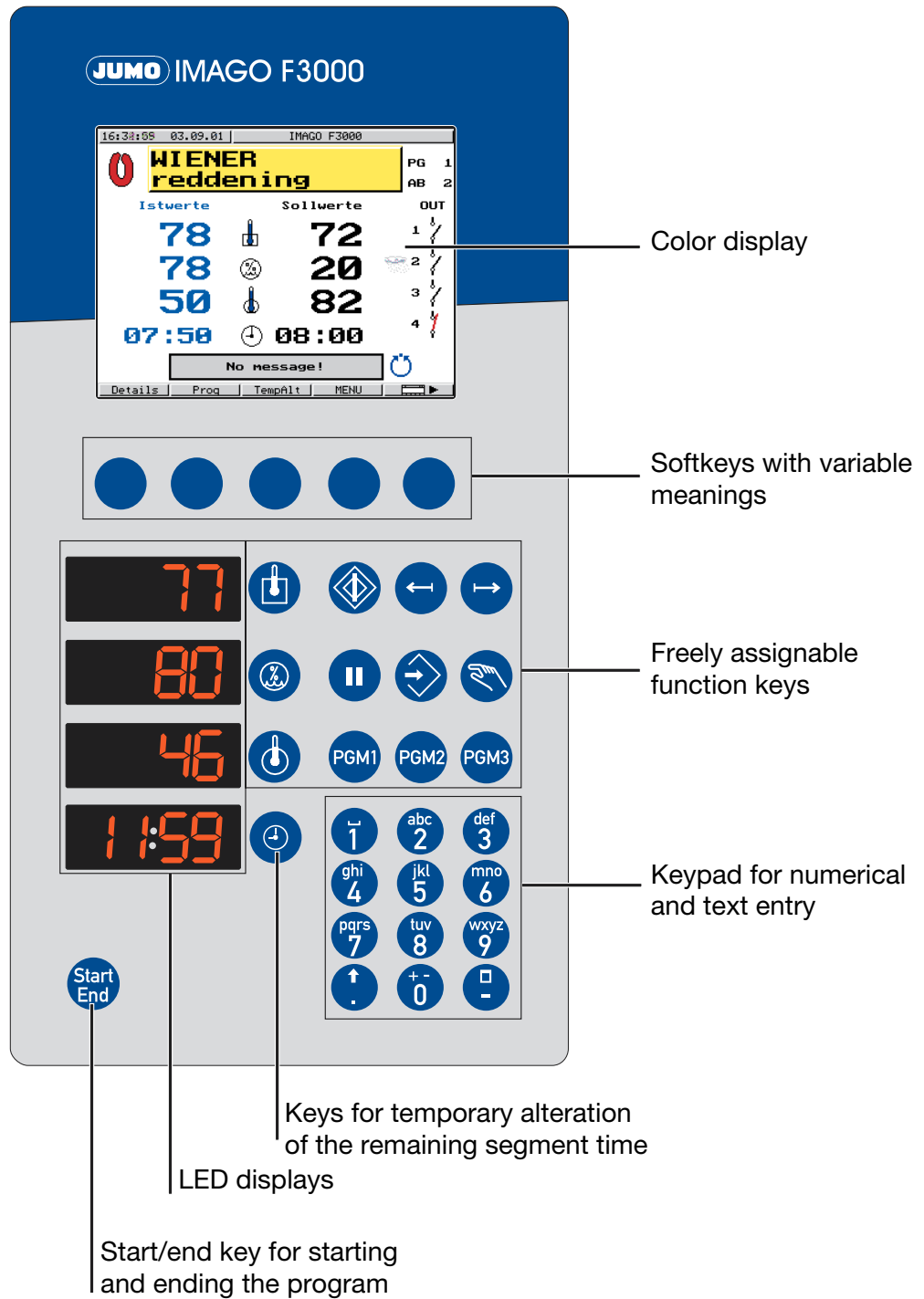

5 Instrument Description

Landscape format

In this format the color display and the softkeys are placed at the left. The function keys correspond to those in the portrait version of the instrument, so it is not necessary to provide another detailed description.

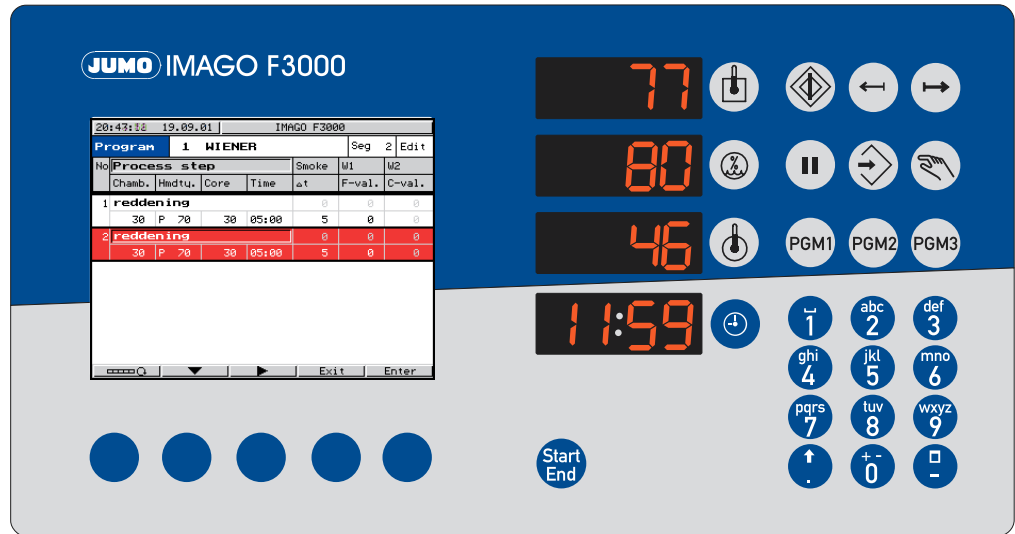



5 Instrument Description

5.1.1 Color screen

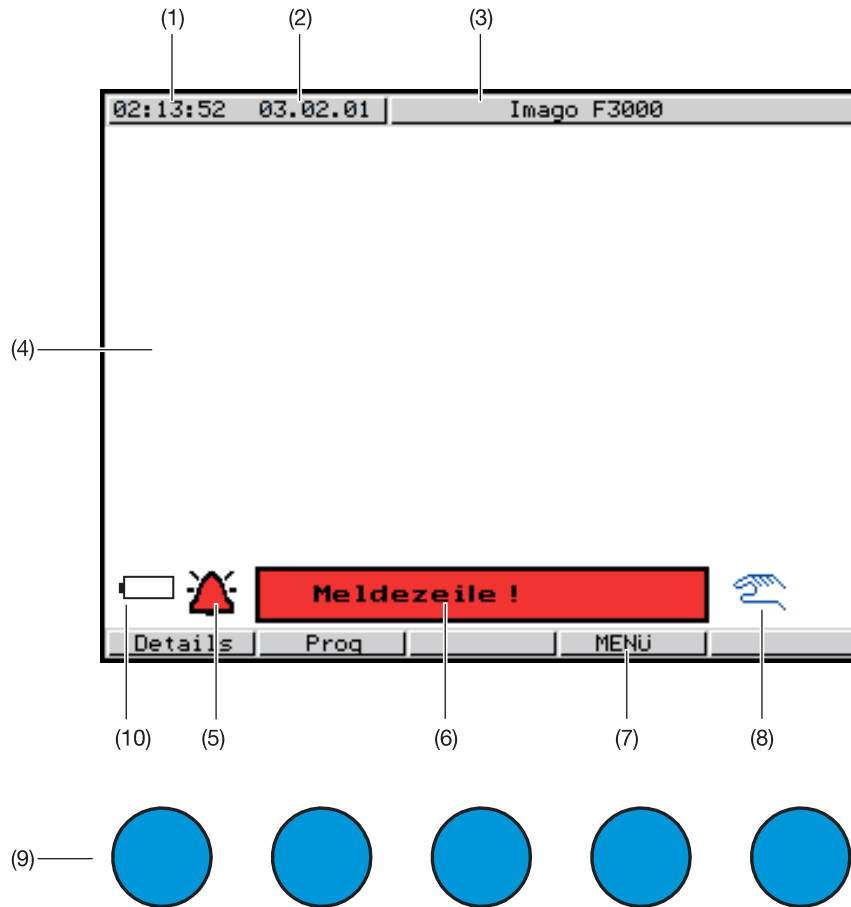
Graphics elements



No.	Field	Meaning
1	Time	⇒ Chapter 6.12.3 “Instrument data”
2	Date	⇒ Chapter 6.12.3 “Instrument data”
3	Manufacturer’s designation or system/plant name	⇒ Chapter 7.6.2 “Instrument data” → <i>Device designation</i>
4	3 freely editable screens	⇒ See “Screen layout”
5	Info icon / alarm bell	 info is available  alarm state
6	Info line / alarm line	This displays either latest info (blue) or alarms (red) ⇒ Chapter 7.7.7 “Logic and alarm functions”
7	Present meaning of softkeys	Pressing on  changes the meaning of all the other function keys ⇒ Chapter 6.2.2 “Program entry”
8	Instrument status	Manual operation, automatic operation, pause, program end
9	Softkeys	Short-action keys with tactile feedback
10	Buffer battery is empty	The battery for the RAM data and time is empty, and must be replaced.

5 Instrument Description

5.1.2 Keypad for numerical and text entry

Function This can be used to enter large or small letters, or numbers, or both, depending on which dialog the instrument is in at the moment.



5.1.3 Freely assignable function keys

As standard, the instrument is delivered with the function keys assigned as shown in the following table.

Standard assignment

Key	Function	Explanation
	Quick Start	the program that was used before is started immediately
	Previous program segment	go back one segment during automatic operation
	Next program segment	go forwards one segment during automatic operation
	Pause	the program sequence is paused during automatic operation
	Change process step	a different process step can be selected during the current process step
	Manual operation	only accessible from the basic status: ⇒ Chapter 6.5 “Manual operation”
	Program1	starts program No.1 from the program list
	Program2	starts program No.2 from the program list
	Program3	starts program No.3 from the program list

The key assignments can be altered within the setup program.





⇒ Chapter 7.7.2 “Function keys”

5 Instrument Description

5.1.4 LED displays

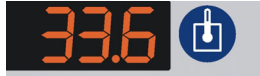
Assignment

The following measurements are shown as standard in the red 7-segment displays:

Chamber temperature	
Relative humidity	
Core temperature	
Remaining program running time in automatic operation. In the basic status, this display shows the time.	

The assignments of the values that are displayed can be altered by the system manufacturer.

⇒ Chapter 7.7.1 “7-segment displays”

5.1.5 Start/End key



This key is used to start or stop programs at any time. The instrument checks for a start delay and product data, as well as for program links.

Start

The program is selected from a list or from program icons.

End

The current program is stopped, without a confirmation query, and the instrument returns to the basic status.

Further info

⇒ Chapter 6.3 “Start program”

5 Instrument Description

5.2 Operating summary

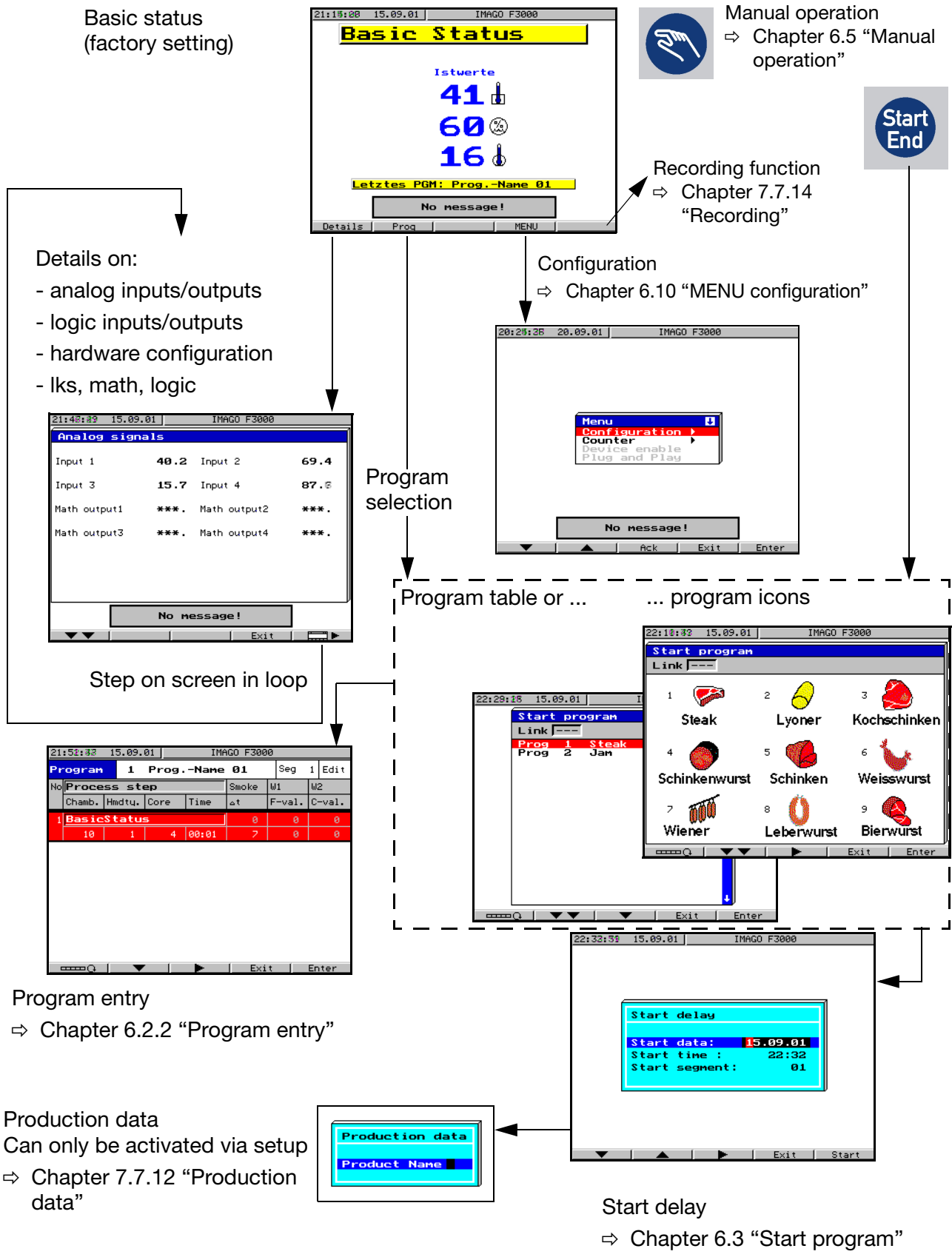

6.1 Basic status

Switch on instrument

If the instrument has been switched on by applying the supply power (power-on) and no program is running, then the screen for the basic status will be displayed.

What is shown?

The values that have already been recorded are shown in the LED displays. The representation on the color screen looks like this:

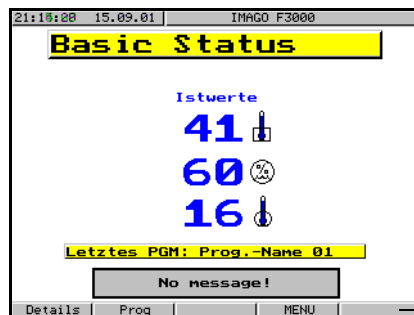

Recording function
⇒ Chapter 7.7.14 "Recording"

Company logo

You can select a different background picture (wallpaper) instead of the one that is set at the factory. This could, for instance, be your own logo or a diagram of the installation.

A bitmap file is required, with a resolution of 320 x 185 pixels in the 16 colors of the standard Windows palette. This can be arranged in the setup program.

Process step

The state of the plant in its initial condition is defined through a process step in the setup program. This process step contains the information on the standby condition of the instrument when no program is running.

This is defined in the setup program.

⇒ Chapter 7.2 "Process steps"

⇒ Chapter 7.4.6 "Program source"

6 Operation

6.2 Program design

6.2.1 General

Program design

Up to 99 programs can be stored in the instrument. Each program can have up to 99 program segments which are processed sequentially.

The instrument can store a maximum of 3600 program segments.

A process step is assigned to each segment. These are normally defined by the system manufacturer, through the setup program.

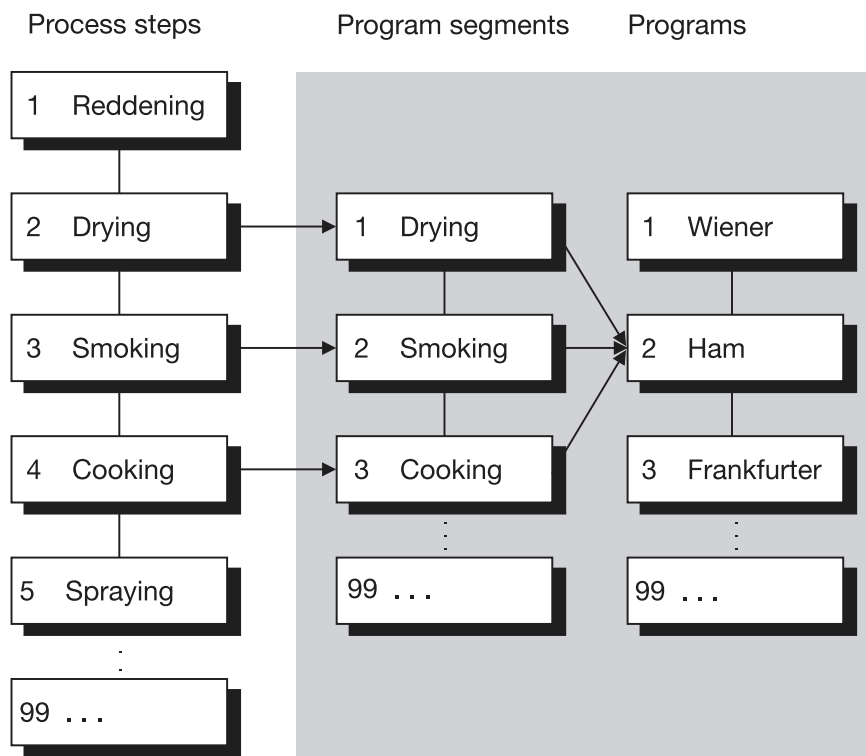

Process steps

Each one of these process steps is associated with a specific state of the process system, which has to be configured by the system manufacturer. The user has no access to this setup, since it requires special knowledge of the system functions and operation.

Up to 99 segments can be programmed, that include

- control functions
- controller parameter sets
- activation of setpoints for controllers and limit parameters
- setpoints

as fixed definitions.



Tip:

The comfortable way of working is to enter the process steps in the setup program, and transfer them to the instrument afterwards. If a few corrections are required, these can be made directly on the instrument.

⇒ Chapter 6.10.7 "Process step editor"

Program segments

During the program entry, the user can add in the following setpoints for the program segments, as defined by the system manufacturer:

- chamber temperature, chamber humidity, core temperature
- delta-cooking, F-value, C-value, intensity of smoke generation, additional values 1 and 2
- Segment running time

The additional values 1 and 2 can be used for special functions that have been assigned to the system.

Programs

Are executable programs that can be linked to one another and designated by a program name or icon.

6.2.2 Program entry

This description assumes that the system manufacturer has already defined the process steps. Process steps can be defined or altered in the instrument or within the setup program.



Programs can not only be put together on the instrument, but also very comfortably by using the PC.

The software to do this is available as an accessory, called **Program editor** IMAGO F3000.

Select program location

- * Press the  key

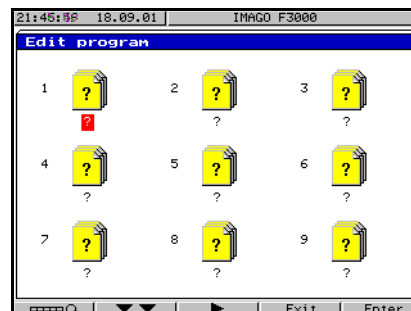

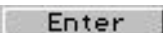
- * Use the arrow keys to select a vacant program location
- * Confirm it with 

Scrolling pages

If a page has been programmed with 5 segments, then the double-arrow keys



can be used to scroll through the pages.

6 Operation

Enter segment

A segment will automatically be defined by process step 1.

gray explanation line:

The step that is active at the moment looks like a “pushed-in” button

red background:

The value that is active at the moment also appears in the program segment as a pushed-in button

No	Process	step	Smoke	W1	W2	Chamb.	Hmdtu.	Core	Time	at	F-val.	C-val.
1	BasicStatus		0	0	0	10	1	4	00:01	7	0	0

white setpoints can be edited

gray setpoints cannot be edited, because they have not been activated by the setup program for this process step

- * Press  and then the window appears for the process steps

No	Process	step	Smoke	W1	W2	Chamb.	Hmdtu.	Core	Time	at	F-val.	C-val.
1	reddening		0	0	0	0	0	0	0	0	0	0
2	drying		0	0	0	0	0	0	0	0	0	0
3	smoking		0	0	0	0	0	0	0	0	0	0
4	cooking		0	0	0	0	0	0	0	0	0	0
5	spraying		0	0	0	0	0	0	0	0	0	0

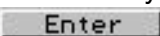
- * Use the arrow keys to select process steps from the list, and acknowledge with 

⇒ See Page 35 “Programming repeated cycles”

- * Use the arrow keys to choose setpoints for chamber, core and segment time. Enter directly on the numerical keypad, confirm with 

Unlimited segment time

Enter 99h:59 min if an unlimited segment time is required.

Chamb.	Hmdtu.	Core	Time	at	F-val.	C-val.
0	0	0	0	0	0	0

Chamb. +00000 °C
+ 20

The window steps on to the next enabled setpoint

- * Repeat the entry procedure until all setpoints have been entered

- * Pressing  results in a new segment being created below the last segment that was entered. One program segment has now been completely programmed, and the setpoints have been accepted.
- * **Enter segment** can be repeated as often as is necessary, until all the segments have been programmed.

Humidity regulation

The relative humidity in the chamber can either be regulated, or controlled through an adjustable on/off (pulse/pause) ratio. Since this setting depends on the system, the system manufacturer gives it a fixed setting for the process step, as “controlled” or “regulated”.

The abbreviation “Pause T” as a softkey will only appear if control is being used, to indicate the pause (OFF time) in humidifying.

The humidifying pulse (ON time) can be adjusted at the configuration level:

⇒ Chapter 6.10.6 “Program source” → *Humidifying pulse time*

The pause time is entered on the instrument.

- * Select the segment: humidity
- * Press  The softkey “Pause T” appears
- * Press “Pause T”

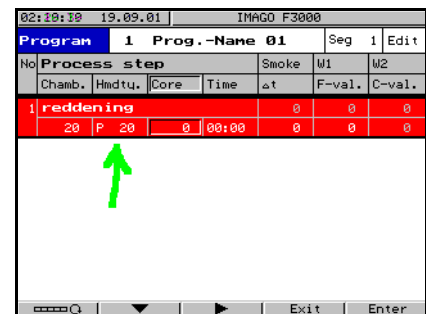
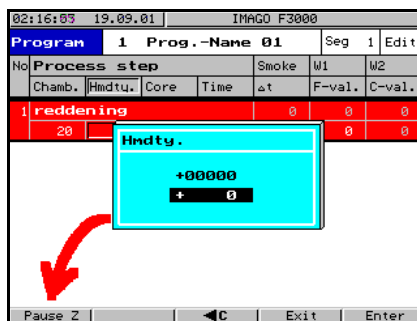

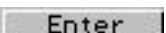
- * Enter the value for the pause time
 - * Confirm the entry with 
- A “P” now appears in front of the setpoint

Humidity controller

Instead of the pause time, just enter a setpoint value. The controller automatically takes care of the chamber humidity.

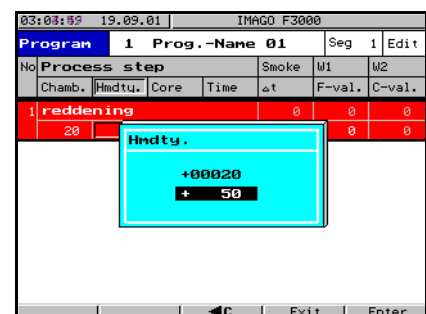
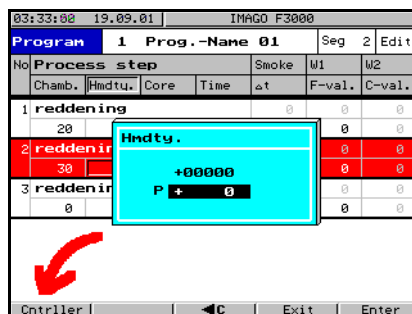

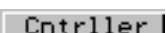
The  key can be used to switch over a segment from humidity regulation back to humidity control.

6 Operation

Wrong entry

Each segment is tested for incorrect entries. If an error message appears, this may be due to several causes:

- 1. Segment incorrectly programmed**
At the very least, a time must be entered with a value greater than 00:00 !
- 2. Value too high or too low**
The value must lie within the measuring range!

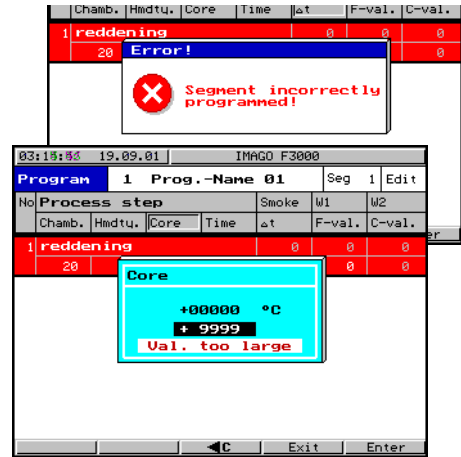

Decimal point

* Press the  key

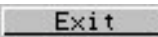
* Leave program entry by pressing 

Assign an icon

The list of programs appears. The newly created program (highlighted in green) is automatically given the name Prog. Name XX.

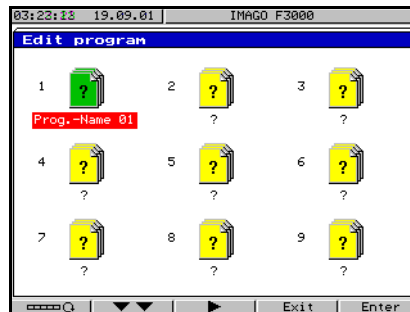

* Press  repeatedly, until  appears

* Press , the selection menu appears

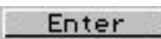

* Confirm icon selection by pressing 

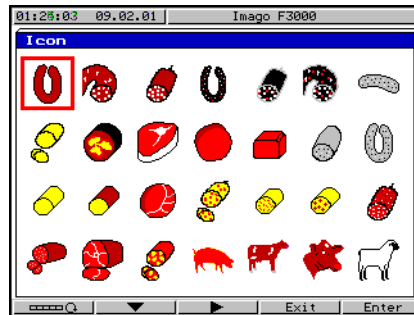

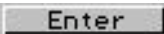
- * Use the arrow keys to select the icon you want, and confirm the selection with 

Enter program name

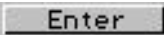
- * Confirm "Edit program name" with 

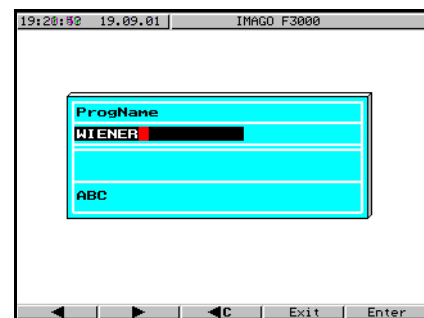
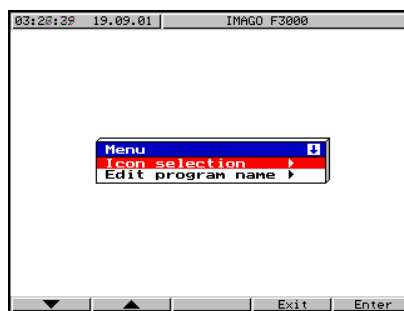

- * Delete the automatically assigned name Prog. Name XX by pressing 

Repeated pressing of the same key brings up the letters with a red background, in the same order in which they are printed on the key.

Example: to get an "R", press the  key 3 times

The letter will be accepted automatically after 3 seconds.

Pressing  deletes a letter

- * Press 

Shift between upper and lower case letters

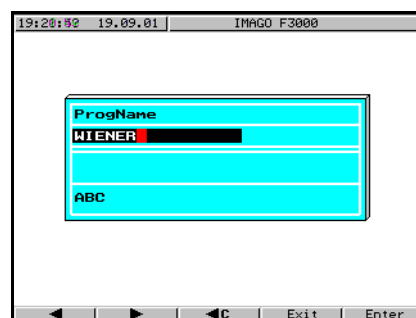

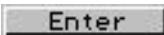
- * Accept the program name with 

6 Operation

Special characters

- * Press 

A window will appear that contains all kinds of special characters. Make a selection with the cursor keys.

End program entry

- * Press "Exit" twice
Program entry is now finished. The instrument returns to the basic status.

Other functions



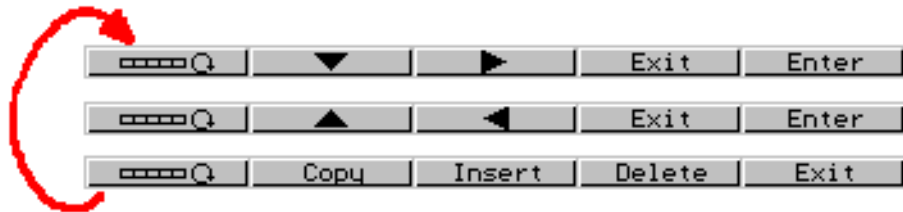

- * During program entry, press  repeatedly, until other functions appear

The arrow keys  and  are used to navigate around a segment.

Rotating through three levels, the meanings change to allow better navigation in the program entry and deleting or copying functions.



Copy or insert a segment

- * Use the arrow keys to select the segment that is to be copied
- * Press  repeatedly, until  appears
- * Press  to copy the segment highlighted in red to the clipboard
- * Use the arrow keys to select the segment in front of which the copy will be inserted
- * Press  to insert the copied segment in front of the one highlighted in red. The following segment numbers will be incremented accordingly.

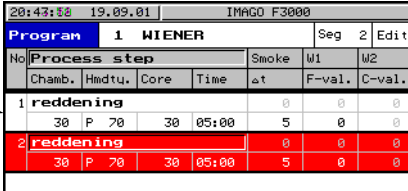



No		Process step				Smoke	W1	W2
Chamb.	Hmdtu.	Core	Time	Δt	F-val.	C-val.		
1	reddening				0	0	0	
	30	P	70	30	05:00	5	0	
2	reddening				0	0	0	
	30	P	70	30	05:00	5	0	



If no segment was copied to the clipboard, then a segment will be inserted that is filled with default values.

Delete a segment

- * Use the arrow keys to select the segment that is to be deleted.
- * Press  repeatedly, until  appears
- * Press  to delete the segment highlighted in red

Copy a program

Use the cursor keys to select the program within the program editing window. Press “copy” and place it in a vacant program location. The first character of the copied program appears as a question mark, and the program name can be altered at will.

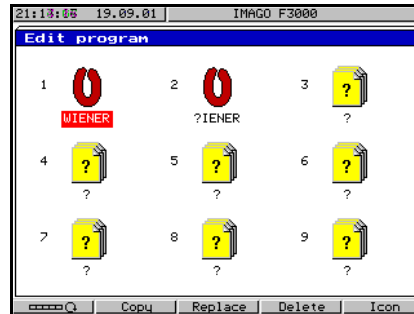

Programming repeated cycles

To do this, **process step 98 (repeat)** must be incorporated into a program segment that is then labeled as a repeat.

When process step 98 is used, the **chamber temperature** acquires the significance of a **jump target segment**. A jump is only permitted to a previous segment. The **core temperature** now takes on the meaning: how often the sequence should be repeated. The **segment time** is now interpreted as the **length of time** during which the repeat is active. All other segment values are inhibited.

Method of operation (if the entry is correct)

When the program reaches the segment that contains the repeat process step, the program will be continuously repeated from the jump target segment on until the length of time that was programmed has elapsed. The total run time for the program will therefore be longer than that given by simply adding up the individual segment times.

When the set time has elapsed, the repeat segment will be skipped and the program will carry on to the end, as entered in the program. The timing response for control functions when using a jump corresponds to that for a manual segment change. Control functions with a timing lead will only be activated when the program enters the target segment. More than one repeat cycle can be entered. There is no additional plausibility check.

Error in a repeat segment

If an incorrect value is entered for the jump target segment or the length of time, then the program will carry on with the next segment.



6 Operation

6.3 Start program

Summary

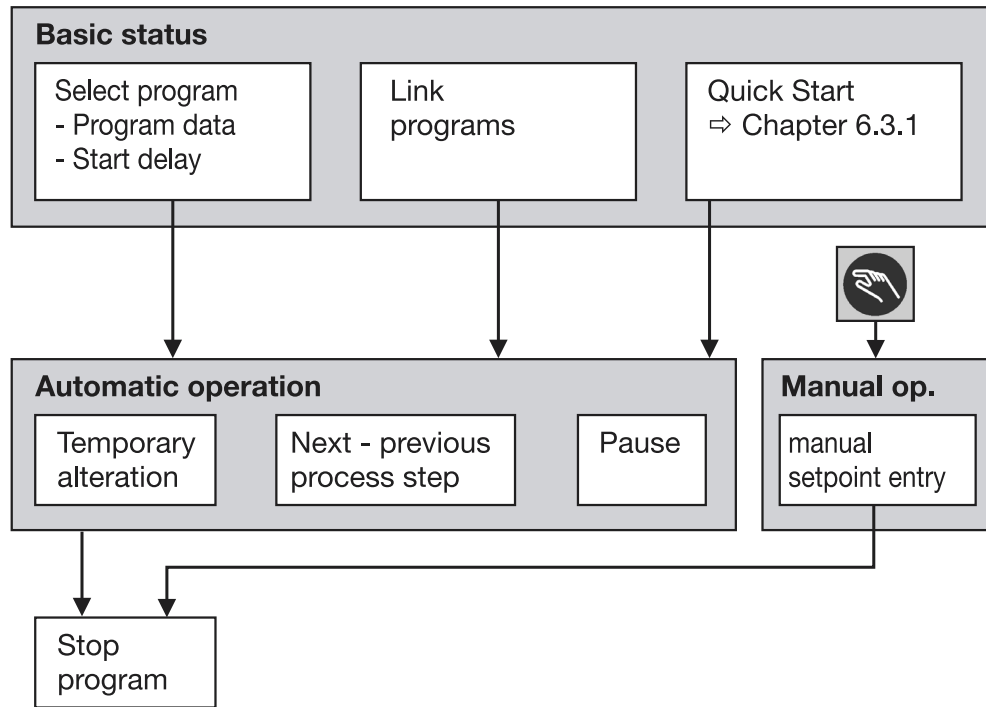

Initiate program start

- * Press the "Start/End" key

Direct program selection

- * Use the arrow keys to select the program from the program or icon list



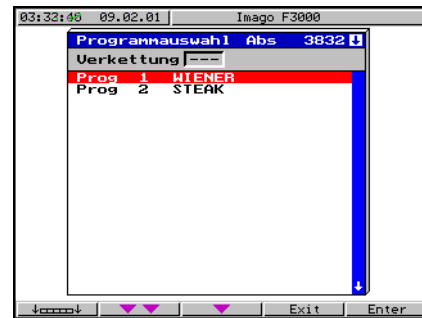

The way the program is shown can be set in the setup program:
 => Chapter 7.6.2 "Instrument data" → *Program selection*



- * Press  to accept the program highlighted in red

Linking programs

Up to 3 programs can be linked together

- * Press  twice
- * Press  (another window appears behind the link)
- * Press 

- * Use the arrow keys to select the program to be linked, and confirm with

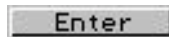



- * Press 

Enter a start delay

It is possible to start the program immediately, using , or to delay the start by up to a month.

- * Enter the date and time on the numerical keypad (numbers 1 to 9)

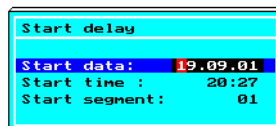

- * Confirm with 

Enter production data



This query will only appear if it has been activated by the setup.
⇒ Chapter 7.7.12 “Production data”

- * Enter the production data from the keyboard

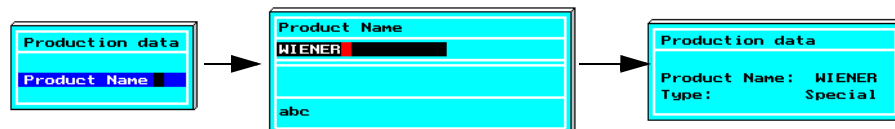

- * Press  and enter the data

- * Confirm with 



As soon as the production data have been confirmed by “Enter”, the instrument returns to automatic operation.

6.3.1 Special function: Quick Start



The most recently used program will be started.

If production data have to be activated in the setup program, these must now be entered.

6 Operation

6.4 Automatic operation



In automatic operation, both process screens are shown with all the setpoints that have been defined. All controllers that have been selected for the process steps are activated, and the “Automatic” symbol appears at bottom right.

Screen changeover

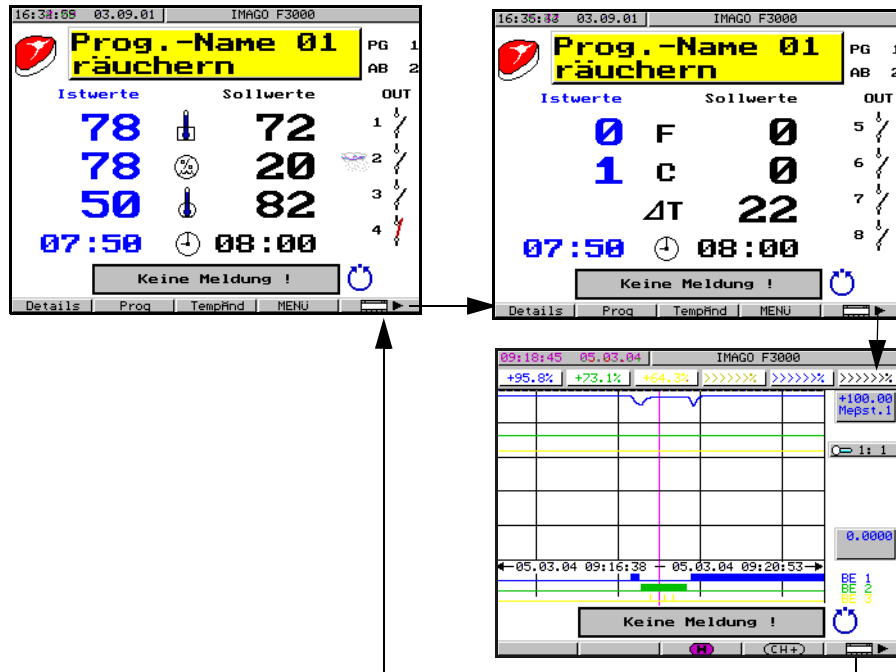

These screen layouts can be freely arranged in the setup
 ⇒ Chapter 7.3 “Screen representation”

6.4.1 Pause program



If this is pressed once, the program run timer is paused, and a coffee-cup symbol appears in the screen at bottom right.

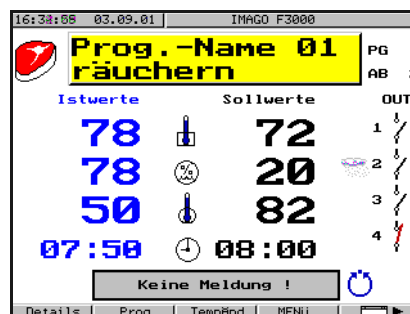

* Press the key again

The coffee cup disappears, and the program continues to run from the point where it was interrupted.

6.4.2 Temporary alterations

– through function keys in the present segment

It is possible to alter the parameters “Process step”, “Chamber temperature”, “Chamber humidity”, “Core temperature” and “Segment time” while the program is running, by using the appropriate function keys.

However, such temporary alterations are only valid for a single run of the program.

When the program is started again, the original values are re-activated.

- * Press “Chamber”, “Core”, “Humidity” or “Segment time”
- * Enter the new value on the keyboard (numbers 1 to 9)

The display accepts the value after 30 seconds, or

- * Confirm with *Enter*.

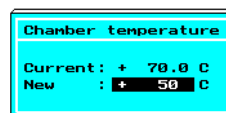

– in the present and all following segments

- * Press the **TempAlt** key

The representation in the display is the same as for program entry.

Features

A segment that has already been processed is marked by “OK”. The present segment is highlighted in red, and marked by an “x”. “Tmp” is shown in the screen at top right.

No		Process step				Smoke	W1	W2
Chamb.	Hmdtu.	Core	Time	Δt	F-val.	C-val.		
1	reddening				0	0	0	
ok	60	70	80	05:00	5	0	0	
2	drying				0	0	0	
ok	70	P 70	50	05:00	5	0	0	
3	smoking				0	0	0	
x	80	10	20	00:45	0	0	0	
4	spraying				0	0	0	
	20	90	15	00:03	0	0	0	

- * Use the arrow keys to move to the value you want
- * Press **Enter** to make a temporary alteration to the selected value
- * Confirm with **Enter**
- * Finish making temporary changes with **Exit**



Segments that have already been processed (marked OK) cannot be altered afterwards!

6 Operation

6.5 Manual operation

Manual operation is initiated from the basic status.



Start

- * Press the  function key

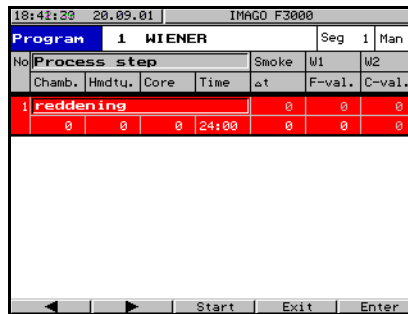
A program segment with process step No. 1 now appears on the color screen, which is distinguished by the text “Man” at top right.

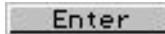

Program		1 WIENER		Seg 1 Man	
No	Process step	Smoke	W1	W2	
Chamb.	Hmdtu.	Core	Time	at	F-val. C-val.
1	reddening	0	0	0	
	0	0	24:00	0	0

- * Use the arrow keys to select the required value or process step
- * Enter the value directly from the keyboard, or
- * Confirm the process step with  and make a selection with the arrow keys
- * After all setpoints have been entered, activate manual operation with the  key





A hand now appears in the screen at bottom right. Manual operation is now active until the preset time has elapsed.

Show setpoints and process values

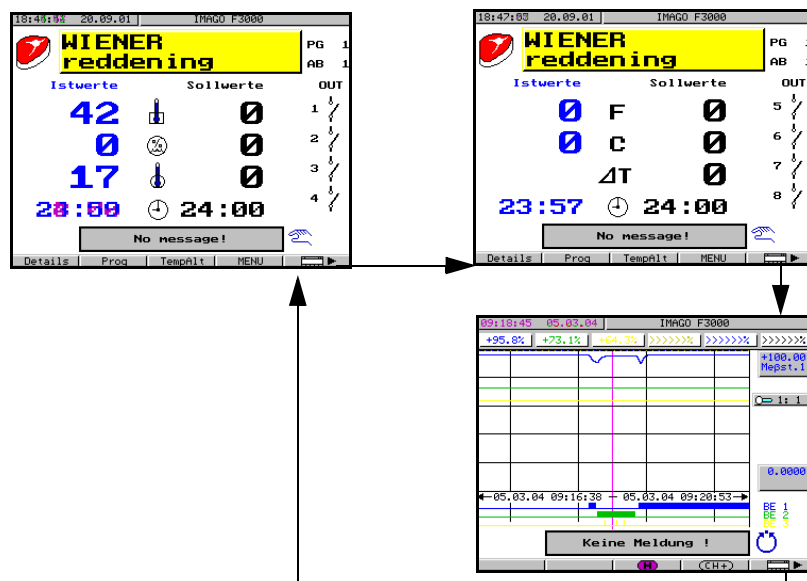
The  key can be used to display other setpoints and actual values that have been entered, as defined in the screen “Automatic2”.







- Alter setpoint**
- * Click on the  key.
A screen appears with one process step, where setpoints can be temporarily altered.
 - * Confirm with *Enter*
 - * Click on *Exit* to activate the new setpoint
-
- End**
- * Click on the  function key again, or click 
- The hand symbol at bottom right disappears.
The instrument returns to the basic status.

6.5.1 Start of self-optimization at the parameter level

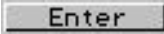

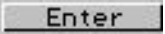
Self-optimization (auto-tuning) is only possible in *Manual* mode!

- * Click on  .
A selection screen will now appear.
- * Select *Configure* and click on  .
- * In the next screen, select *Parameterization* and click on  .
- * Select *Self-optimization* and click on  .
- * Select the controller
- * Select the parameter set for saving data that are determined.
- * Set the status to *Active*.

In the initial screen,  and  will blink alternately, until self-optimization is finished. The duration of self-optimization depends on the control loop, and can be even longer than 1 hour.



Self-optimization will be canceled if:

- the segment time has expired, or
- a measurement error (overrange/underrange) occurs.

6 Operation

6.6 Stop program

All programs which are running in automatic operation or manual operation can be stopped by using the “Start/End” key.

- * Press the “Start/End” key



The symbols for automatic or manual operation at the bottom right of the screen are no longer visible, and the instrument returns to the basic status.

6.7 Program end signal

The program end signal becomes active at the end of a program. The duration of this signal and the relay that it operates can be defined.

⇒ Chapter 6.10.6 “Program source”

Chapter 7.4.6 “Program source”

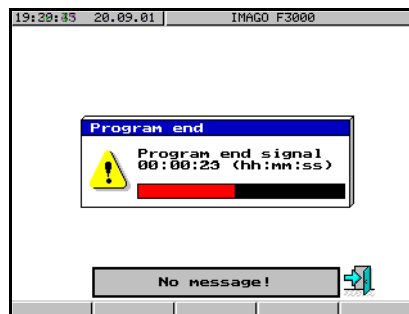

6.8 Acknowledging alarms

All alarms will trigger the combined alarm, and must be acknowledged by the operator. The combined alarm will only be de-activated when this is done, even if the originating alarm was already inactive.

Acknowledgement is made as follows:

- * In the present screen template, use the *Menu* button to change to the menu level. If an alarm has occurred, the softkey *Ack* will be shown here.

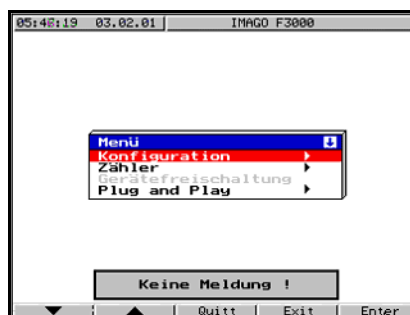

- * Click on *Ack* to acknowledge the alarm.

6.9 General

The instrument can be completely configured through the setup program. There are just a few parameters that can only be set in the instrument. Many functions can be set up in the instrument, using the MENU key, as well as through the setup program.



This is a summary of settings that only need to be made once per installation, and are therefore very rarely changed.

Summary

The configuration is divided into 3 levels and protected by a password.

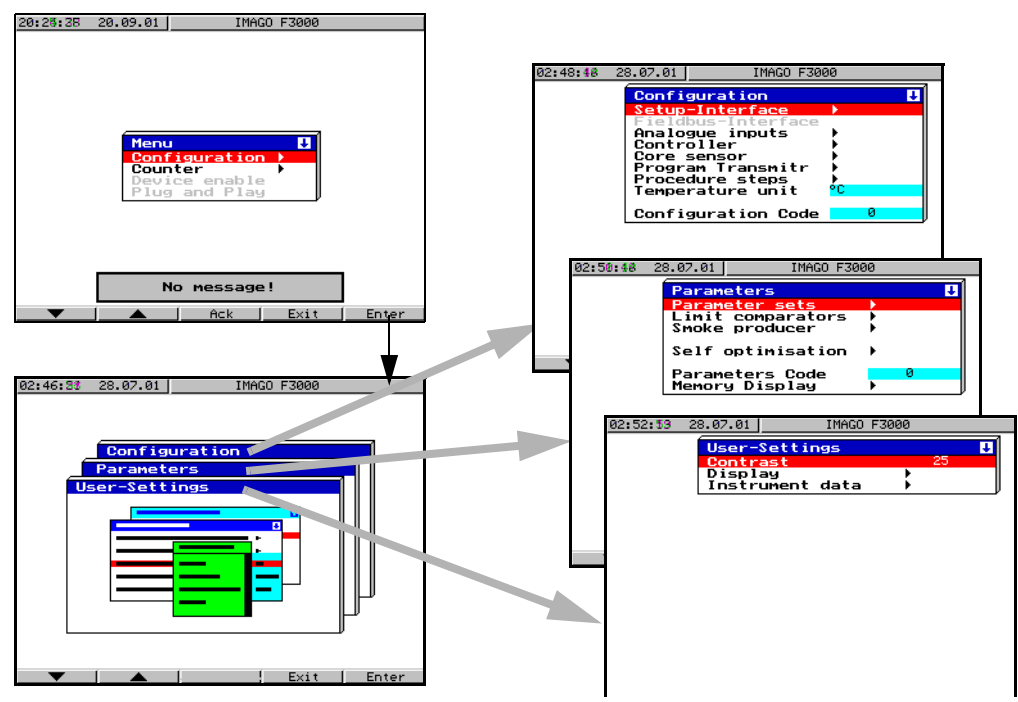

6.10 MENU configuration

6.10.1 Setup interface

A connection to the setup program can only be established if the settings match those in the device list.

⇒ Chapter 7 “Setup Program” *Device list*

6.10.2 Fieldbus interface

This interface is used for communication with process control systems, and is available as an option “Universal interface” for slot 3.

⇒ Chapter 4.2.4 “Universal interface (slot 3)”

6 Operation

6.10.3 Analog inputs

Here you can make the configuration settings for probe type, linearization, measurement range limits and offset.

All unused inputs are shown in gray and cannot be configured. As soon as the instrument detects a new plug-in module, the color changes to black.

As delivered ex-factory, 4 analog inputs can be configured.

⇒ Chapter 7.4.3 “Analog inputs”

6.10.4 Controller

Here you can define the settings for controller inputs, controller type, activation of self-optimization, and the output level feedback.

⇒ Chapter 7.4.4 “Controller”

6.10.5 Core probe

Here you can define the method that will be used to determine the core temperature.

⇒ Chapter 7.4.5 “Core changeover”

6.10.6 Program source

Restart data, program end signal, segment step-on, setpoint limits, decimal places and setpoint values for the basic status are all set up here.

⇒ Chapter 7.4.6 “Program source”

6.10.7 Process step editor

In the setup program

Process steps can be entered in the instrument, and very comfortably through the setup.

⇒ Chapter 7.2 “Process steps”

In the instrument

In the instrument, the function is accessed through the **MENU** key.

- * In the basic status, click on **MENU**
- * Select *Configuration* → *Configuration* → *Process steps*
A list appears of all the process steps that have been set up.



- * Use the arrow keys to select the process step you want, and confirm with **Enter**

Here you can set up the control contacts, adjustable values, controllers, limit comparators and setpoints within the limits given and as explained in the set-up program.



⇒ Chapter 7.2.2 “Editing process steps”

- * Confirm all entries with **Enter**

6.10.8 Temperature unit

Here you can set the dimensional unit to be used for the display of temperature setpoints and actual values.

⇒ Chapter 7.6.2 “Instrument data”

6.10.9 Password (config)

The factory-set password is 9200. The password can be defined separately for

6 Operation

the parameter and configuration levels.

⇒ Chapter 7.6.2 “Instrument data”

6.11 MENU parameterization

This includes all the settings that must be made during commissioning and adapted to suit the system during test running.

6.11.1 Controller parameter sets

8 different parameter sets can be entered here.

⇒ Chapter 7.5.1 “Controller parameters”

The assignment of the parameter sets to the controllers is made during the definition of the process steps.

⇒ Chapter 7.2 “Process steps”

6.11.2 Limit comparators

Here you can enter the switching action, limits, switching differential, action and switching status on probe break.

⇒ Chapter 7.5.2 “Limit comparators”

6.11.3 Smoke generator

The settings for operating a smoke generator with a conveyor screw are made here.

Chapter 7.5.3 “Smoke generator”

6.11.4 Self-optimization

Here you can define which controllers are to be optimized, and which parameter set is to be used to store the parameters which are determined.

Self-optimization can only be initiated on the instrument itself, in *Manual* mode.

⇒ Chapter 6.5 “Manual operation”

6.11.5 Password (parameter)

The factory-set password is 9200. The password can be defined separately for the parameter and configuration levels.

⇒ Chapter 7.6.2 “Instrument data”

6.12 User data

The settings are not protected by a password, and can be set up individually by each user.

6.12.1 Contrast

This alters the brightness of the screen.

6.12.2 Display

Here you can define a time after which the screen goes dark, or light up the screen for a preset length of time.

6.12.3 Instrument data

Instrument data which can be set are: the instrument name at the top of the screen, local language, date/time and summer-time changeover, and the type and method of program selection.

Program password

The entry and alteration of programs can be protected by a 4-character password.

No password protection is set (0000) in the factory.

The window for making changes to the password will only appear if the presently valid password or the password for the parameter or configuration level is entered.



6.13 MENU counter

The counter is an operating-hours counter. It is used to record the running time of external equipment, such as a pump. The counter starts to run when a logic signal changes state to a logical "1".

If the counter has reached a preset value, then an output is set. This output can be used to operate a relay or produce an alarm signal.

6.14 MENU device access

Enabling access to the device can be understood as follows: the OEM manufacturer can deliver the equipment to the end user with access enabled for a fixed period. At the end of this period it is no longer possible to run a program, and a password must be used to enable the system again.

6 Operation

6.15 Plug & Play (P&P)

Explanation The Plug & Play memory is available as an option. The Plug & Play memory is used for automatic saving of the configuration, the programs and the process steps. It is also possible to load a new version of the instrument software into the Imago F3000.

Indication You can recognize the operating status from the color of the diskette symbol for the P&P memory, in the screen at bottom right.

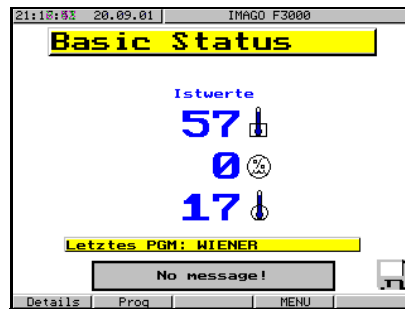

Diskette color	Explanation
gray	Plug & Play memory is inserted correctly, no other function
blue	Plug & Play memory is inserted correctly, automatic saving is active

Applications

- **Duplicate the IMAGO F3000**

This creates an image copy of an instrument, so that if it is transferred to an unconfigured instrument, this instrument will behave exactly like the first one.

- **Copy programs**

to another instrument.

- **Data backup in the event of a fault**





The automatic save must be activated in order for the instrument to automatically record all the changes up to the time of the fault.

⇒ Chapter 6.15.2 “Activate automatic save”

A faulty instrument can be replaced without any problems, by inserting the Plug & Play memory into the new instrument.

LED indication A red LED indicates the operating status.

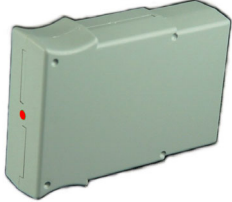
LED indication	Explanation
LED off	Plug & Play memory not inserted correctly

<p>LED lit up continuously</p> 	<p>Plug & Play memory is active</p>
<p>LED blinks</p>	<p>Plug & Play module is being accessed at the moment</p>  <p>The Plug & Play memory must not be removed while the LED is blinking.</p>

Password comparison

The password for the configuration level is stored in the Plug & Play memory. If the module is plugged into another instrument, the passwords are compared, and data can only be read out if the passwords match. The screen indicates that it is not possible to read out data from the Plug & Play memory.

The symbol of a canceled Plug & Play memory will appear if:

- There is a hardware difference between the source and target devices.
- The write protection is active (see Chapter 6.15.3 “Activate/de-activate write protection”).

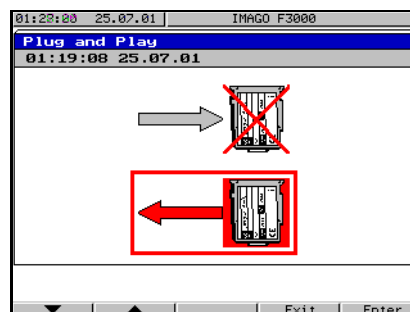

Transmission can still be selected, even if the hardware is different!

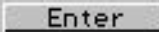
* Acknowledge with 

Another window now appears, with a more detailed description of the error. For instance: differences in hardware equipment levels when copying data from one instrument to another.

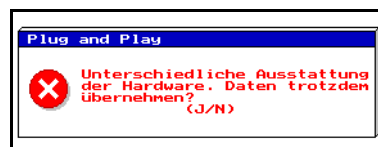

6 Operation

6.15.1 Write data to P&P memory

- * Click on the  button

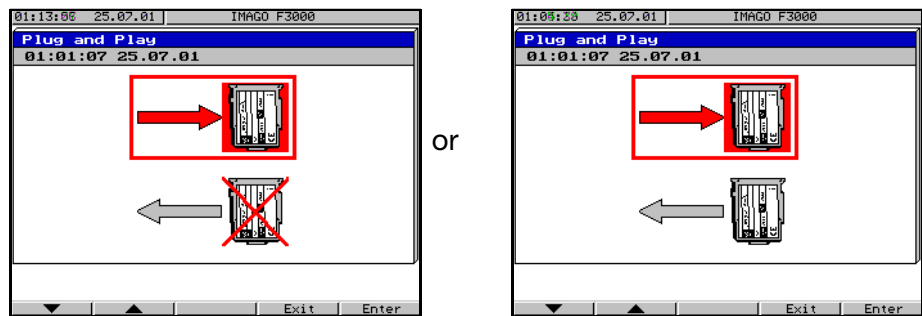

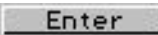
- * Acknowledge with 

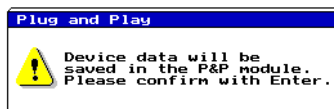

- * Confirm with 



All previously stored data in the P&P memory will be overwritten.

6.15.2 Activate automatic save

When automatic save is used, all changes to the instrument are permanently updated in the P&P memory.

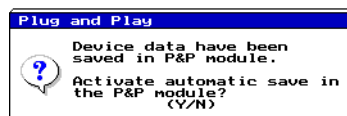

- * Click on Yes

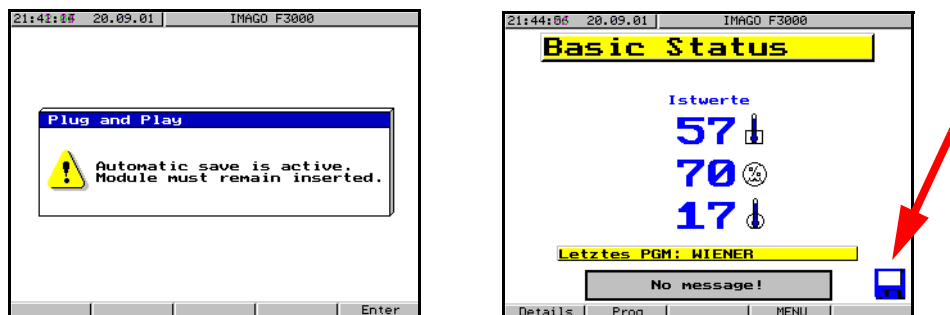

The gray diskette symbol changes its color to blue.

6.15.3 Activate/de-activate write protection

This write protection has a similar function to the write-protect tab on a diskette.

Activate

This function is set in the Plug & Play menu

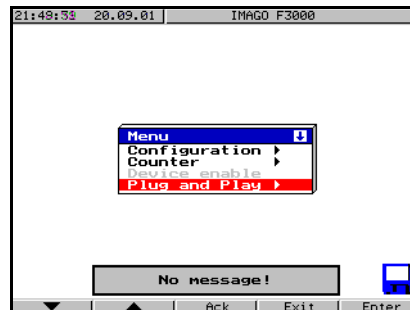

* Confirm with 

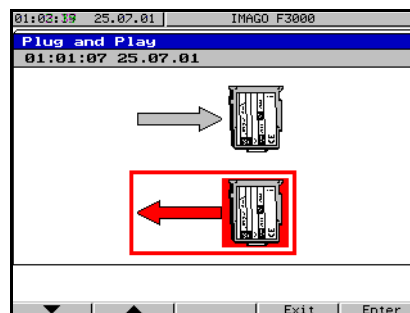

* Press 

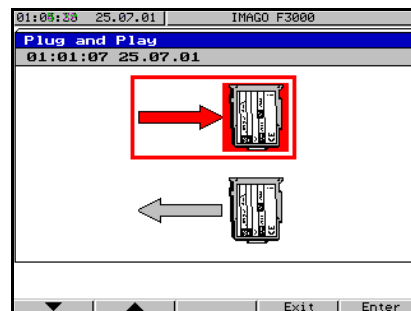

or

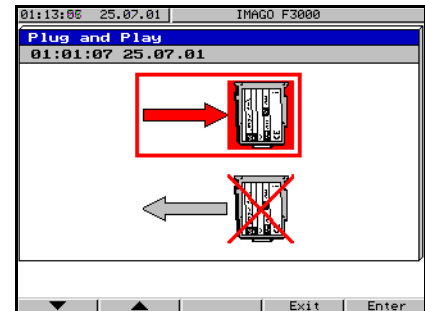

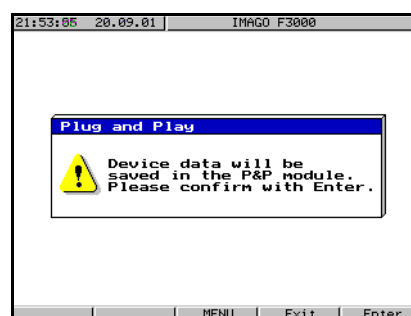

* Acknowledge with 



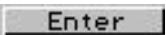

* Press the  key

6 Operation

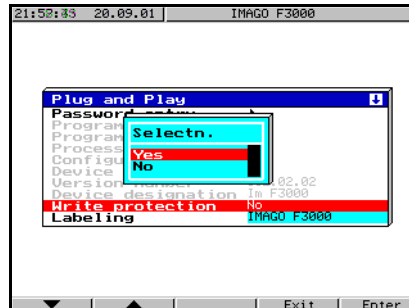
- * Select *Password entry* and enter the configuration password.
- * Use the  or  key to select write-protection
- * Press 

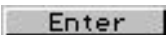
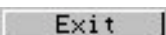
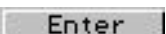

- * Select Yes, by using the  or  key
- * Confirm with 
- * Press 
- * Use  to save the latest data in the memory, and then set the write protection.

Since it is no longer possible to write to the P&P memory, any previously activated automatic save is now impossible, and the following message appears:

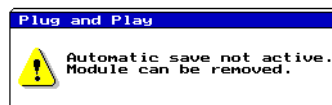

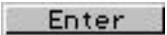
- * Acknowledge with 

Representation

Write protection is represented by a canceled P&P memory symbol.

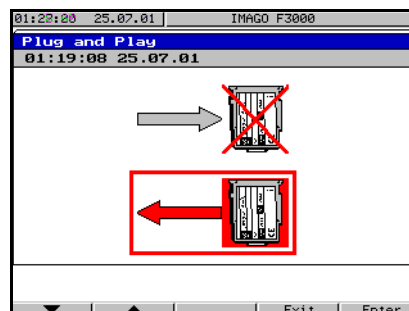

- * Click on  and 

Remove write protection

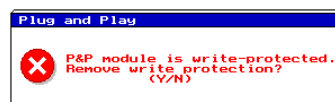

- * Click on Yes
- It is now possible to write to the P&P memory again.

6.15.4 Copying programs

The system always writes all the programs into the memory. However, it is possible to make a selection of the programs when reading the contents out into another instrument.

Data source

- * Insert the P&P memory
- * Write all the data to the P&P memory

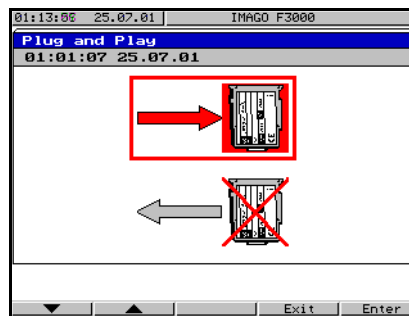

Data target

- * Remove the P&P memory and insert it into a new instrument

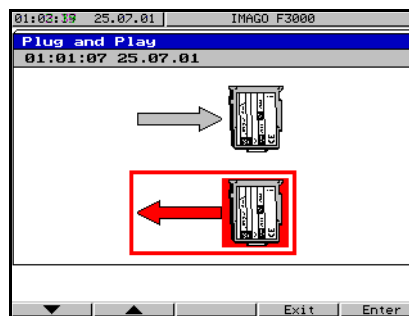

- * Press
- * Press the key

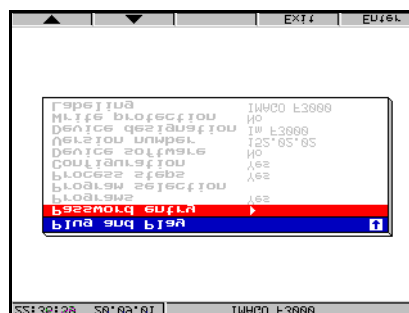

- * Select password entry
- * Press
- * Enter the password



The password in the P&P memory (source instrument) must match the password for the configuration level of the target instrument.

6 Operation

- * Go to the program selection, and
- * Select the program to be copied (a tick appears)

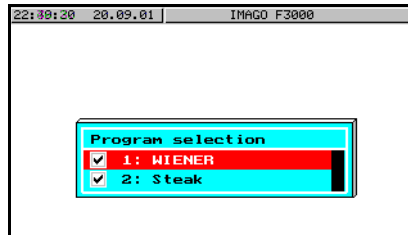

- * Confirm with 

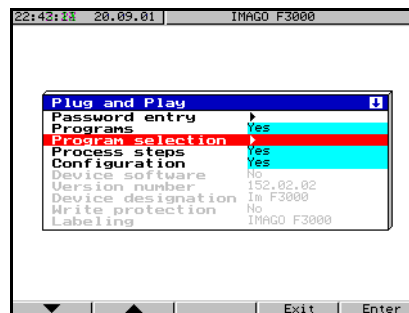

All the data marked by Yes will be copied from the P&P memory.

6.15.5 Replacing a faulty device

Condition

The data must have been stored in the memory by automatic save before the device became faulty.

⇒ Chapter 6.15.2 “Activate automatic save”

- * Replace the faulty device by a new one
- * Insert the P&P memory into the new device
The read symbol will appear.

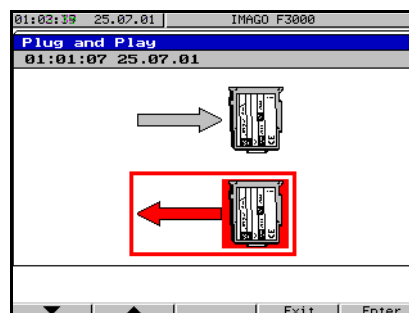

- * Acknowledge with 



A message informs you that the data are being loaded into the instrument.

- * Acknowledge with 

6.15.6 Retrofitting a P&P memory

If no P&P memory has been inserted previously, then it must first be recognized by the instrument.

- * Insert the P&P memory (available as an accessory)
A gray diskette symbol should appear in the screen at bottom right

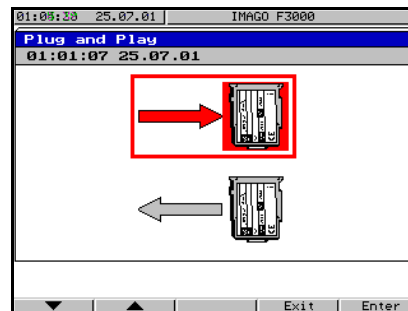

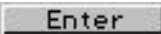
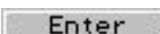
- * Acknowledge with 
- * Confirm the security query with  as well.

6.15.7 Making a backup copy

⇒ Chapter 6.15.1 “Write data to P&P memory”

6.15.8 Commissioning a new instrument

This involves copying all the data from a write-protected P&P memory to a new instrument.

⇒ Chapter 6.15.4 “Copying programs”

6.15.9 P&P memory, programming by OEM

⇒ Chapter 6.15.1 “Write data to P&P memory”

6.15.10 Loading data for a write-protected P&P memory on site

- * Insert the P&P memory
The symbol for a write-protected P&P memory appears

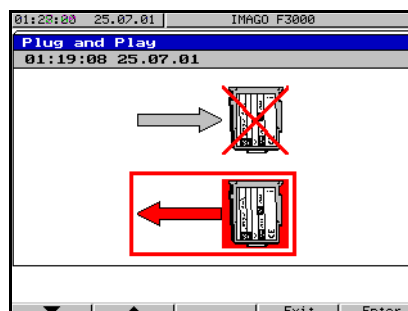



- * Confirm with 

6 Operation

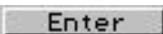

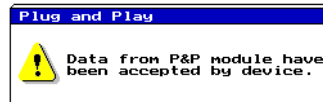
- * Confirm with 
A progress bar appears, to indicate that the data are being copied and have been accepted.





- * Acknowledge with 

6.15.11 Load new instrument software

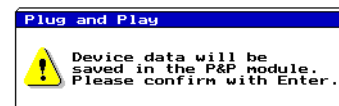
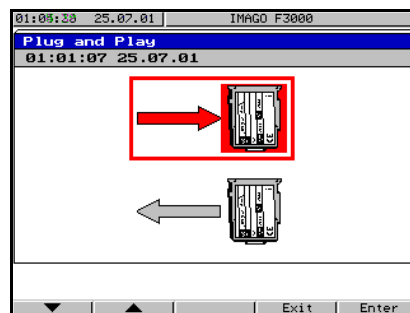
- * Load the instrument software into the P&P memory

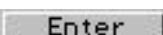

- * Confirm with 
A message indicates that data are being loaded into the P&P memory.
- * Press the  button
- * Select *Password entry*, and enter the password for the configuration level

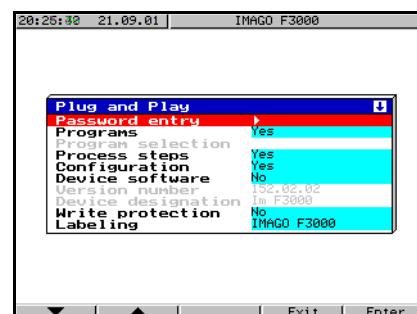
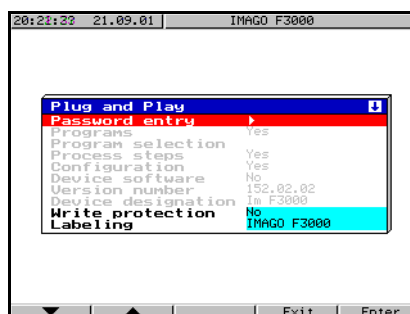

After entering the password, the gray lettering changes color to black, to indicate that the instrument software can now be set.

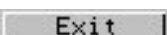
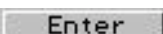
- * Set instrument software to Yes
- * Click on 
- * Confirm with 
A progress bar shows that the data are being loaded and accepted.



The transmission of the data will take somewhat longer (about 3 - 4 minutes! The screen will go dark while this is going on → **In no circumstances** should you remove the P&P memory or switch off the device!

Press *No*, so that no automatic save is made, which would delete the instrument software.

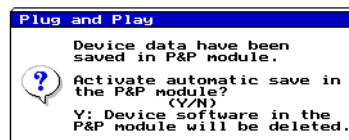

- * Click on *No*
- * The P&P memory can now be inserted into another instrument
The read symbol will appear.

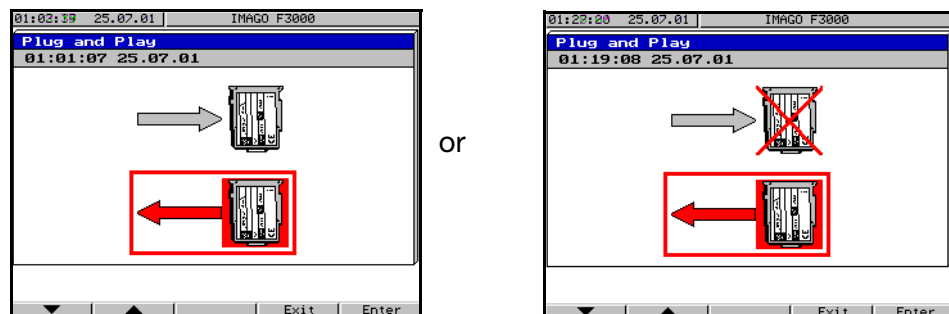

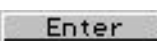
- * Acknowledge with 



A message appears to show that data are being loaded into the instrument.



The device now carries out a restart (the screen goes dark), making the restart with the new device software.

This procedure takes about 90 seconds, and must not be interrupted by switching off the supply voltage or by removing the P&P memory.

6.16 Instrument-only settings

Function	MENU / Chapter
Contrast	<i>Configuration</i> → <i>Instrument data</i> via arrow keys from 0 to 100%
Self-optimization	<i>Configuration</i> → <i>Parameterization</i> → <i>Self-optimization</i>

6 Operation

Access authorization

The range of functions that is available in the setup program can be restricted by applying a “Specialist” password.

“Specialist” access is extended to cover the following functions:

- Instrument calibration (analog inputs and outputs)
- Test functions
- Undocumented parameters (additional functions)
- Definition of system texts

“Specialist” access can be protected by the use of a password.

File → Password



If no password is defined, then “Specialist” access will be available without restriction.

If a password has been defined, then “Maintenance” access only provides access to the setup program.

Device list

For communication with one or more instruments, the PC interface has to be configured and entered in a device list.

Data transfer → Establish connection (F2)

The settings for the device addresses and interface parameters must match those for the instrument (= device).

Pressing the Save button stores the settings permanently (also for later program calls).

Communication with the instrument can be protected by a password. The password is defined in the instrument.

Device assistant

Whenever a new configuration file is created, the hardware configuration of the attached instrument must be transmitted to the setup program. The entry options for doing this are as follows:

Edit → Hardware

User-defined setting:

The assignments of the slots are selected manually, through pull-down menus.

Entry of the type code:

The hardware configuration is defined by entering the type code.

Automatic detection:

The hardware configuration is read out from the instrument. To do this, the instrument must be connected and the interface must be configured.

Factory setting:

The hardware setting is defined as the default setting for the standard version of the instrument (see data sheet).

7 Setup Program

General

The complete configuration of the instrument is shown in the desktop display. Clicking on the arrows next to the headings brings up the configuration data for the individual functions. A double-click on an individual parameter brings up the corresponding entry form.

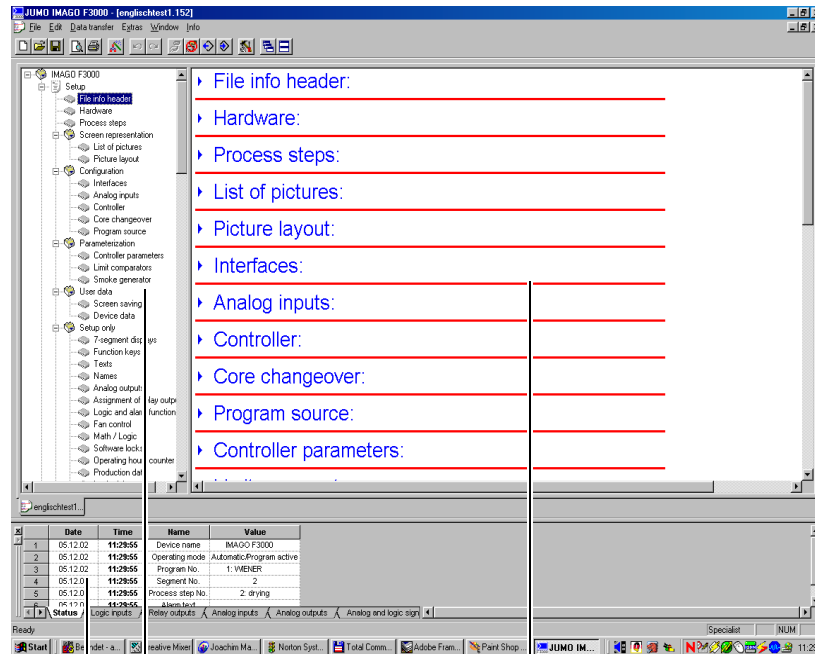

Navigation tree
to find setup settings and program names quickly

Dialog window
to display the setup settings and the program editor table

Teleservice window
for remote monitoring of an instrument via a modem

The entry forms for the individual functions can also be accessed through the *Edit* menu.

7.1 Selectors

Selectors are the selection menus that open out for setting up individual parameters. The range of choices available for inputs and outputs depends on the hardware configuration level of the instrument.

In order to maintain clarity, two standard selectors have been defined for the following configuration tables:

Analog selector

Selection	Description
Switched off	Switched off
Analog input 1 — 8	Signals from the analog inputs
Relative humidity	Relative humidity
X core	Actual core temperature (adjusted process)
X F-value	Actual (process) F-value

7 Setup Program

Selection	Description
X C-value	Actual C-value
W chamber	Setpoint for the chamber
W chamber display	Chamber setpoint, taking into account the delta-cooking procedure
W humidity	Humidity setpoint
W humidity pulse time	Humidity setpoint, using humidity regulation
W core	Core setpoint
W DeltaT	DeltaT setpoint
W F-value	Setpoint for F-value
W C-value	Setpoint for C-value
W intensity, smoke generator 1	Setpoint for smoke intensity
W extra 1+2	Extra setpoints
W 1 – 5 (process step)	Setpoints for the process step
Math 1 – 4	Calculated results from the math functions
Control deviation 1 – 4	Control deviations
Output 1, controller 1 – 4 (prop.)	Output signals from the first controller
Output 2, controller 1 – 4 (prop.)	Output signals from the second controller
Output level, controller 1 – 4	Output levels of the controllers
Present process step	Process step number
Present program number	Program number
Present segment number	Segment number
Ext. setpoint 1 – 4 (interface)	External setpoints from the MODbus interface
Reserve A1 – A10	-

Logic selector

Selection	Description
Switched off	Switched off
Combined alarm	Combined alarm
Logic input 1 – 32	Signals from the logic inputs
Control contact 1 – 36	Signals for the control functions
Limit comparator 1 – 8	Signals from the limit comparators
Logic 1 – 8	Logical results from the logic functions
Output 1, cntrl 1 – 4 (switching)	Output signals from the first controller
Output 2, cntrl 1 – 4 (switching)	Output signals from the second controller
Program end signal	Program end signal
Fan stage 1 – 3	Fan control
Ignite smoke generator 1+2	Signal for ignition of smoke generators
Intens., smoke gen. 1 (interface)	Control signal for smoke generator 1
Ext. logic input 1 – 4 (interface)	External logic inputs from the MODbus interface
Humidity regulation	Logic signal for active humidity regulation in the present segment
Active	Logical 1 (Yes)
Inactive	Logical 0 (No)
Logic 9 – 16	
Logic delay 1 – 8	Logic inputs with delay
Markers 1 – 4	
Manual mode	
Automatic mode	
Pause mode	
Reserve 1 – 15	

7.2.2 Editing process steps

Control contacts

This defines whether a control contact is active during this process step, and which type of switching action it follows.

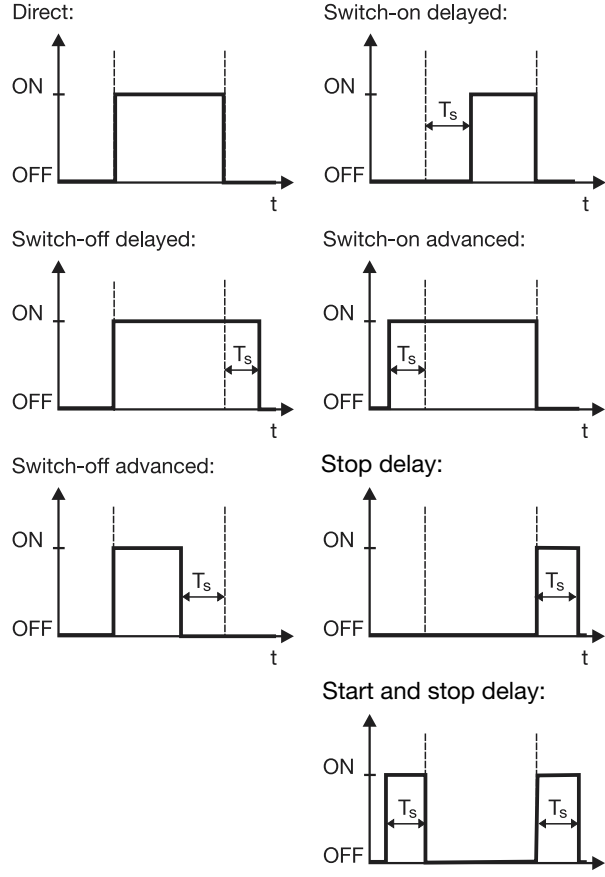
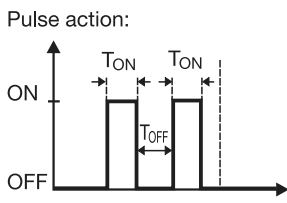
Selection/setting	Description
Switching action No response Switching is activated	Defines whether a control contact should use a specific type of switching action.
Function Direct action Switch-on delayed Switch-off delayed Switch-on advanced Switch-off advanced Stop delay Start and stop delay	 <p style="text-align: center;">T_s = control function time</p>
Control function time	0 – 32767sec see above
ON pulse time	0 – 32767sec
OFF pause time	0 – 32767sec Defines a pulse action while the contact is active, always starting with T_{ON} Example (“Direct”):  <p style="text-align: center;">T_{ON} = ON pulse time T_{OFF} = OFF pause time</p>

■ / bold = factory setting

7 Setup Program

Adjustable values

You can select which parameters are intended to be editable on the instrument during the process step.

- Chamber setpoint
- Humidity setpoint
- Core setpoint
- Delta T setpoint
- F-value setpoint
- C-value setpoint
- Extra setpoint 1
- Extra setpoint 2
- Smoke generator intensity
- Program pause (with door contact closed):
The program segment time is stopped while the corresponding door contact is closed.
- Program pause and all outputs off (with door contact open):
If the door contact is open, all relays drop out and the outputs produce their initial signals. The device also goes into the program pause mode.
- Program pause and all outputs off (with door contact closed):
If the corresponding door contact is closed, all the relays drop out and the outputs produce their initial signals. The device also goes into the program pause mode.
- Humidity control:
The humidity is not controlled during the process step, but regulated by a pulse/pause ratio.



Values which are not selected will be shown in gray in the program editor, and it will not be possible to alter them!

Controller

The controllers (controller 1 – 4) and their corresponding parameter sets (parameter sets 1 – 8) can be activated for the process step.

Limit comparators

The limit comparators (limit comparator 1 – 8) which are relevant to the process step can be activated.

Setpoints

Setpoints 1 – 4 are defined for the process step, and can be switched to active so that they can be entered in the program segment.

Max. time

This represents the maximum segment run time in minutes. This means that the program will not permit a time to be entered that is longer than this value.

Permissible values are from 0 to 5999. If 0 is entered, the time is unlimited.

- Procedure**
- * Define a name for the process step
 - * Mark the control contact in the list
 - * Activate the control contact
 - * Define the switching action and the switching times
 - * Define which values are to be adjustable within the process step
 - * Activate the controllers and limit comparators for the process step
 - * Define setpoint 1 – 5
 - * Press *OK*

7.3 Screen representation

2 screen layouts can be freely arranged in the Imago F3000. However, this can only be done via the setup program.

- List of pictures** This is a library within the setup program that contains the wallpaper/highlight colors for icons and program icons.
-

- Screen layout** Here you can arrange the positions of the displayed values, icons, objects, and the background/highlight colors for the screen.
⇒ Operating Instructions B 70.0101.6 (on CD)

7.4 Configuration

7.4.1 Interfaces

A setup program can be transmitted via one of the three interfaces. The instrument must have the same interface settings as the setup program.

- 1.) Setup interface for the PC interface (blue connector 15)
 - 2.) Interface for teleservice/visualization (RS422/485 connector 13)
 - 3.) Universal interface for MODbus (RS422/485 connector 3)
- ⇒ Chapter 4.2 “Connection diagram”

7 Setup Program

7.4.2 Special settings in interface operation with mTRON modules

In the setup program, in the menu:

Device list → *Properties* → *Features* → *Expanded*

the value for the word length must not be larger than 30!

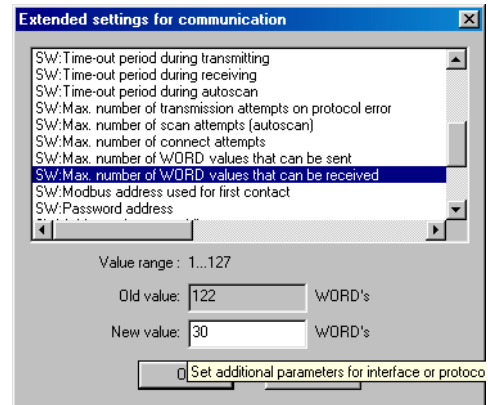
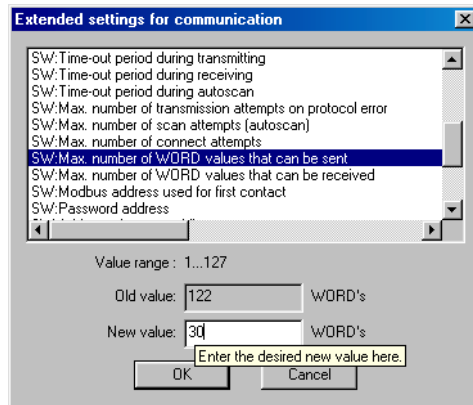

7.4.3 Analog inputs

Up to eight analog inputs are available.

Analog input 1 – 8

	Selection/settings	Description								
Probe type	No function	Defines the type of probe/sensor to be connected to the individual analog input.								
	Resistance thermometer									
	Thermocouple									
	Voltage 0 – 1000mV									
	Voltage 0 – 10V									
	Current 0 – 20mA Current 4 – 20mA									
Linearization	Linear	Defines the linearization function for the sensor.								
	Pt100	The display depends on the type of sensor that has been set.								
	Fe-Con J									
	NiCr-Ni K									
	Fe-Con L									
Measuring range										
Start	-1999 to 0 to +9999 °C/°F (depending on the sensor type and linearization) ⇒ Data Sheet 70.0101	For standard signals: Defines the display value (measurement) for the start of the input signal range.								
End	-1999 to 0 to +9999 °C/°F (depending on the sensor type and linearization) ⇒ Data sheet 70.0101	The value defines the display value (measurement) for the end of the input signal range.								
Offset	-1999 to 0.0 to +9999 °C/°F	The offset is used to correct the measurement upwards or downwards by a fixed amount.								
		<p>Examples:</p> <table border="1"> <thead> <tr> <th>Measured value</th> <th>Offset</th> <th>Displayed value</th> </tr> </thead> <tbody> <tr> <td>294.7</td> <td>+0.3</td> <td>295.0</td> </tr> <tr> <td>295.3</td> <td>- 0.3</td> <td>295.0</td> </tr> </tbody> </table> <p> The controller uses the corrected value (= displayed value) for its calculations. This value is not the same as the value at the point of measurement. Incorrect use of this function may produce impermissible values for the control variable.</p>	Measured value	Offset	Displayed value	294.7	+0.3	295.0	295.3	- 0.3
Measured value	Offset	Displayed value								
294.7	+0.3	295.0								
295.3	- 0.3	295.0								
Humidity calculation										
Humidity calculation	ON	The analog input 1 (or one of 3 – 8) is used to acquire the dry temperature. Analog input 2 is used to acquire the wet temperature. This two values are used to calculate the psychrometric humidity.								
	OFF									
Dry temperature	Analog input 1	Source for dry temperature								

■ / bold = factory setting

7 Setup Program

	Selection/settings	Description
Filter time constant	0.0 – 1.5 – 40.0sec	For adjustment of the 2nd. order digital input filter. 0 sec = filter OFF For a step change in the signal, the response is 63% of the change after 2x filter time constant. If the filter time constant is long: - high damping of interference signals - slow response of the process value display to changes in the process value - low upper frequency limit (2nd. order low-pass filter)

■ / bold = factory setting

7.4.4 Controller

The type of controller and the input variables are defined here. Settings are also made for self-optimization on the unit.

Controller 1–4

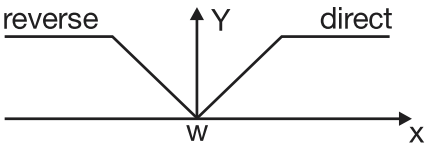
	Selection/settings	Description
Controller type	Inactive	Defines the type of controller
	Single-setpoint controller ¹	
	Double-setpoint controller ²	
	Modulating controller	
	Proportional controller with integrated actuator driver	
Action	Proportional controller	 <p>Reversed: The output level Y of the controller is > 0 if the process value is smaller than the setpoint (e.g. heating).</p> <p>Direct: The output level Y of the controller is > 0 if the process value is larger than the setpoint (e.g. cooling).</p>
	Reversed	

■ / bold = factory setting

1. factory setting for controllers 3 and 4

2. factory setting for controllers 1 and 2

7 Setup Program

Controller inputs

Process value
Setpoint selection
Output level feedback

Selection/settings	Description
(Analog selector)	Defines the signal sources for the process value, setpoint, output level feedback

■ / bold = factory setting

Factory settings

Controller	Process value	Setpoint	Output level feedback
1	Analog input 1	W chamber	off
2	Relative humidity	W humidity	off
3	off	off	off
4	off	off	off

Self-optimization (TUNE)

Self-optimization

Selection/settings	Description
Enabled	Defines whether it is possible to start the self-optimization on the unit.
Inhibited	
Relay and logic	The hardware type of the outputs which are assigned to the controller outputs must be set here.
Solid-state	
Analog	

Controller output 1 for TUNE

Controller output 2 for TUNE

■ / bold = factory setting

Method

The self-optimization function SO determines the optimum controller parameters for a PID or PI controller.

The following controller parameters are determined, depending on the type of controller:

Reset time (T_{n1} , T_{n2}), derivative time (T_{v1} , T_{v2}), proportional band (X_{p1} , X_{p2}), switching cycle time (C_{y1} , C_{y2}), filter time constant (dF).

The controller selects one of two methods, **a** or **b**, depending on the size of the control deviations:

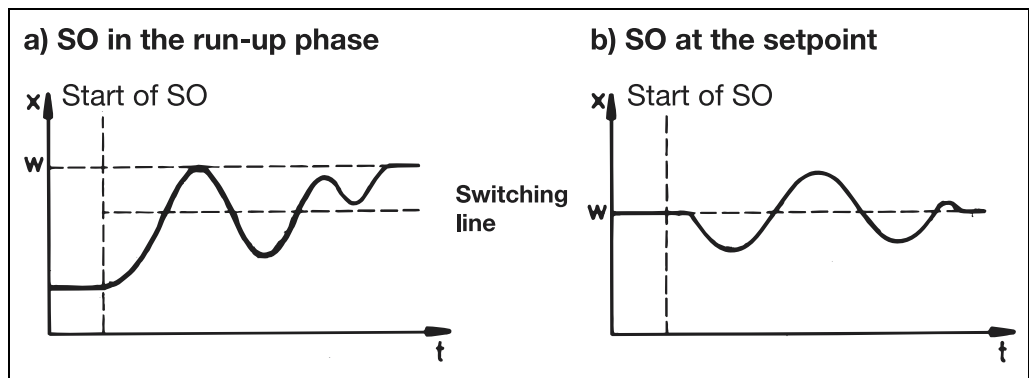

7 Setup Program

7.4.5 Core changeover

Up to 4 temperature sensors can be used to acquire the core temperature. The following methods are available:

	Selection/settings	Description
Selection method	None	No selection; output is the replacement value.
	Minimum of signals 1–4	Minimum of signals 1–4: The smallest value measured counts as the core temperature.
	Maximum of signals 1–4	Maximum of signals 1–4: The largest value measured counts as the core temperature.
	First valid measurement from signals 1–4	First valid measurement from signals 1–4: If one or more probes have a fault, then the next valid measurement is taken as the core temperature (sequence: signal 1 – signal 4).
	Average of signals 1–4	An average is formed, and this is then used as the core temperature measurement.
Replacement value for probe break	Error message	The replacement value can either be a value that is output to replace the missing core temperature, or an error message.
	Chamber process value	
Signal 1 – 4	(Analog selector)	Signal sources for the core temperature
	OFF ¹	
	Analog input 3 ²	

■ / bold = factory setting

1. factory settings for signals 2 – 4
2. factory setting for signal 1

7.4.6 Program source

Various parameters that influence the running of the program are set here.

General

	Selection/settings	Description
Restart after power interruption	Cancel program	The program is canceled:
	Continue from interruption	The present program is canceled at the point of the power interruption.
	Standstill	The instrument is then in the basic status.
	Continue at X % chamber temp.	Continue: The instrument continues the program automatically from the point where the interruption occurred. Standstill: When power returns, the program remains in standstill at the point where the interruption occurred. "Standstill" appears in the alarm line. The program can be canceled or continued from the keyboard. Continue at X % chamber temp. If the difference between the actual temperature in the chamber before and after the power interruption is no larger than this % value, then the program continues automatically. If the difference is larger, then the instrument responds as for standstill.
Program end time	0 – 60 – 9999sec	Duration of the program end signal ⇒ Chapter 7.7.6 "Assignment of the relay outputs"
	Process value signals	
Chamber	(Analog selector)	Signal sources for chamber and core temperatures
Core	Analog input 1 ¹	If the actual value (process value) in the chamber goes beyond the measuring range limits, all controllers will be switched off.
	Analog input 3 ²	
Pulse time for humidity control	0 – 5 – 9999sec	The ON time for the humidifier. The pause (OFF) time is entered in the program ⇒ Chapter 6.2.2 "Program entry"
Segment step-on core/time	Core OR time	Condition for stepping on to the next segment: Reaching the core setpoint AND/OR elapse of the segment time.
	Core AND time	

■ / bold = factory setting

7 Setup Program

Extended

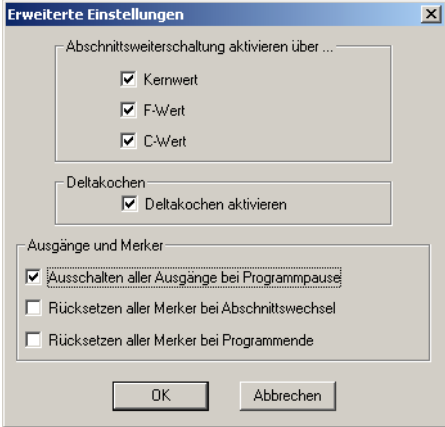
Selection/settings	Description
<p>Step-on through: Core value, F-value, C-value, Delta cooking active/inactive</p> <p>Outputs and markers for: Program pause, Segment change or Program end.</p>	<p>With check mark: step-on is active for the corresponding value.</p>  <p>Without check mark: step-on condition is inactive.</p>

■ / bold = factory setting

1. factory setting for chamber
2. factory setting for core

Setpoint limits

Limits can be defined for the setpoint entry on the instrument.

Value range

The range of values for all setpoints is 0 – 999.

Setpoint 0 means that the function is inactive.

Decimal places

One, two or three decimal places can be defined for the entry and display of the setpoints.

Factory setting: no decimal places

Factory setting

Setpoints		Setpoints in process steps	
Chamber	0 – 200	Setpoint 1	-199 – 999
Humidity	0 – 100	Setpoint 2	-199 – 999
Core	0 – 200	Setpoint 3	-199 – 999
Delta T	0 – 100	Setpoint 4	-199 – 999
F-value	0 – 999	Setpoint 5	0 – 5999
C-value	0 – 999		
Smoke intensity	0 – 100		
Add.1	0 – 999		
Add.2	0 – 999		

Basic status

All the setpoints that are active in the basic status are defined here.

Factory setting

The factory setting for all setpoints in the basic status is 0.
These settings are contained in process step 99.

7.5 Parameterization

7.5.1 Controller parameters

The controller parameters are used to adapt the controller to the control loop.

Controller parameter set 1 – 8

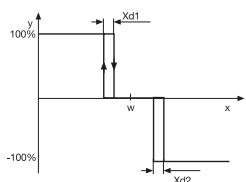
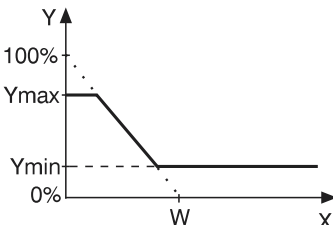
	Selection/settings	Description
Controller structure	P, I, PD, PI, PID	Controller structure 2 for the output of a double-setpoint controller. Modulating controllers can only use PI or PID.
Proportional band	0 – 9999	Xp1, Xp2 The controller structure is ineffective if Xp1, 2 = 0 ! (thermostat function) Xp1, 2 must be > 0 for proportional controllers.
Derivative time	0 – 80 – 9999 sec	Tv1, Tv2
Reset time	0 – 350 – 9999 sec	Tn1, Tn2
Switching cycle time	0 – 20 – 9999 sec	Cy1, Cy2 With a switching output, the switching cycle should be chosen so that the pulsewise energy feed does not cause impermissible fluctuations in the process values, while at the same time not overloading the switching devices through excessive switching.
Contact spacing	0 – 9999	Xsh Spacing between the two control contacts in double-setpoint or modulating controllers, or proportional controllers with integral actuator driver.
Switching differential	0 – 1 – 9999	Xd1, Xd2 Hysteresis in switching controllers with Xp = 0 
Actuator time	15 – 60 – 3000 sec	TT The time range used for the regulator valve in double-setpoint controllers or proportional controllers with an integrated actuator driver.
Working point	-100 – 0 – +100 %	Y0 Output level for P and PD controllers (for x = w , y = Y0)
Output level max. limit	0 to 100 %	Y1, Y2
Output level min. limit	-100 to +100 %	Output level limiting restricts the controller output signal to values between the maximum (Y _{max.}) and minimum (Y _{min.}) limits. Example: in a proportional controller 
Minimum relay ON time	0 – 60 sec	TK1, TK2 Limits the frequency of output switching.

■ / bold = factory setting

7 Setup Program

7.5.2 Limit comparators

Limit comparators (limit monitors, limit contacts) are used to monitor the size of an input variable (actual value for the comparator) in comparison with a fixed threshold or another variable (set value for the comparator). If the signal goes beyond the limit (threshold) a signal can be output or an internal function can be initiated.

Limit comparators 1 – 8

	Selection/settings	Description
Function	No function	Switching function of the limit comparator, see description below
	Ik1 – Ik8	
LK actual value	(Analog selector)	Signal sources for the input variables to the limit comparator
LK set value	OFF	
Action	Absolute	See description below
	Relative	
Time	0 – 32000sec	Delay time for the “Relative” action
Limit value (AL)	-199.0 to 0 to +999.9	Defines the switching point of the limit comparator
Switching differential (Xsd)	0.0 – 1.0 – 999.9	Hysteresis
Switch-on delay on segment change	0 – 32000sec	The time delay when the segment changes
Function for overrange / underrange	Relay drops out	The response if one of the input variables goes above/below the given range
	Relay pulls in	

■ / bold = factory setting

Limit comparator functions



If times are entered under Relative / Absolute and Switch-on delay, then both of them are always active!

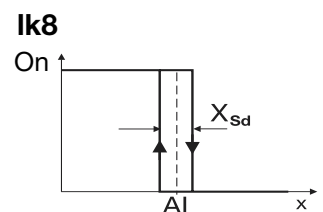
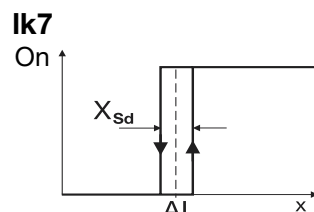
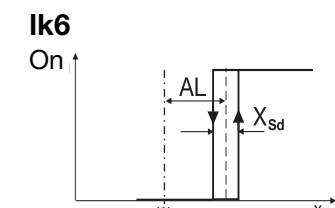
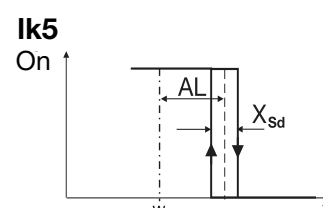
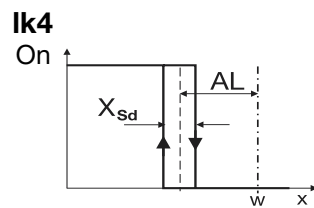
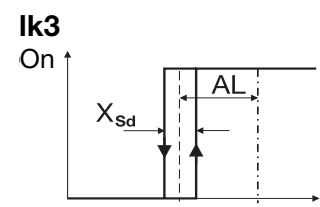
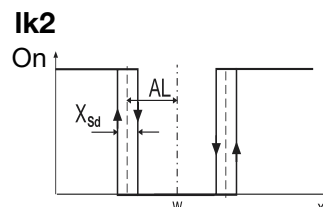
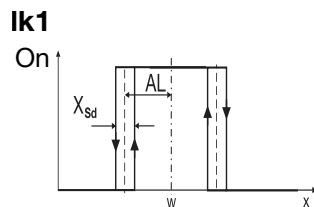

Ik1 – Ik6: Monitoring relative to the limit comparator setpoint.
Ik7/Ik8: Monitoring relative to a fixed limit AL

w = set value for limit comparator, AL = limit,
x = actual value for limit comparator, X_{Sd} = switching differential

Action

Absolute:

At the moment of change, the limit comparator responds with its normal function.

Relative:

The limit comparator is in the OFF state.

If a change of the limit value or the (limit comparator) set value occurs that would normally cause the comparator to switch to the ON state, this reaction is suppressed. This condition remains in force until the actual input value to the comparator has **again** gone outside the switching region (gray area).

Example:

Monitoring the process value x of the controller, using the lk4 function

Setpoint change $w_1 \rightarrow w_2$

a) Initial state

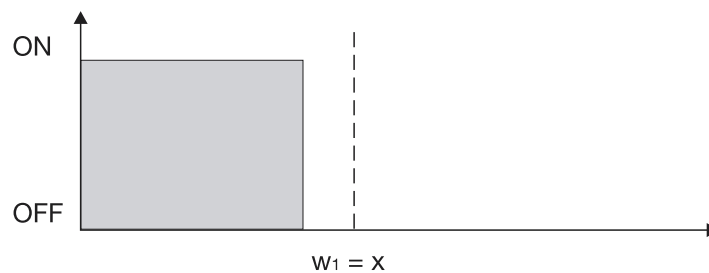

b) State at the moment of change.

The limit comparator remains OFF, although the actual value has moved into the switching region!

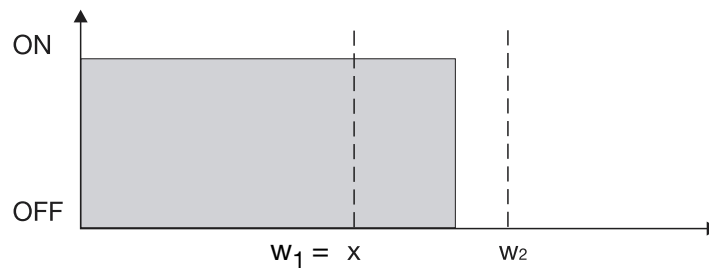

c) Controlled state

The limit comparator continues to fulfil its normal function.

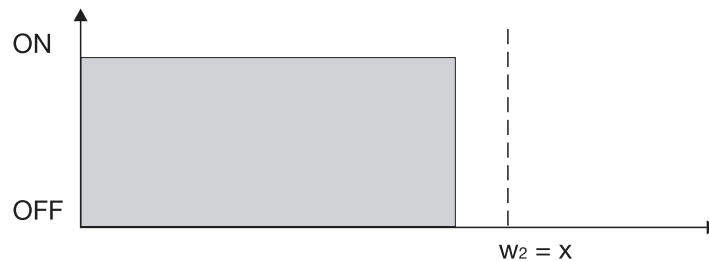

This function is used, for example, to prevent a limit comparator switching during the run-up phase.

7 Setup Program

7.5.3 Smoke generator

Two smoke generators can be configured. The parameters for the conveyor screw can only be set for smoke generator 1.

	Selection/settings	Description
Control contact	(Logic selector)	Logic signal used to activate the smoke generator.
	OFF	
Ignition time t1	0 – 9999sec	Duration of the ignition for the smoke generator.
Running time for conveyor screw t2	0 – 8 – 9999sec	The running time for the conveyor screw.
Max. pause time t3	0 – 9999 sec	The time after which sawdust needs to be fed in again.

■ / bold = factory setting

Description

The smoke generator is activated by a logic signal. Two outputs operate the ignition of the sawdust and its transport (only for smoke generator 1). While the program is running, the smoke intensity can be regulated by entering a setpoint W_{SMOKE} in the program.

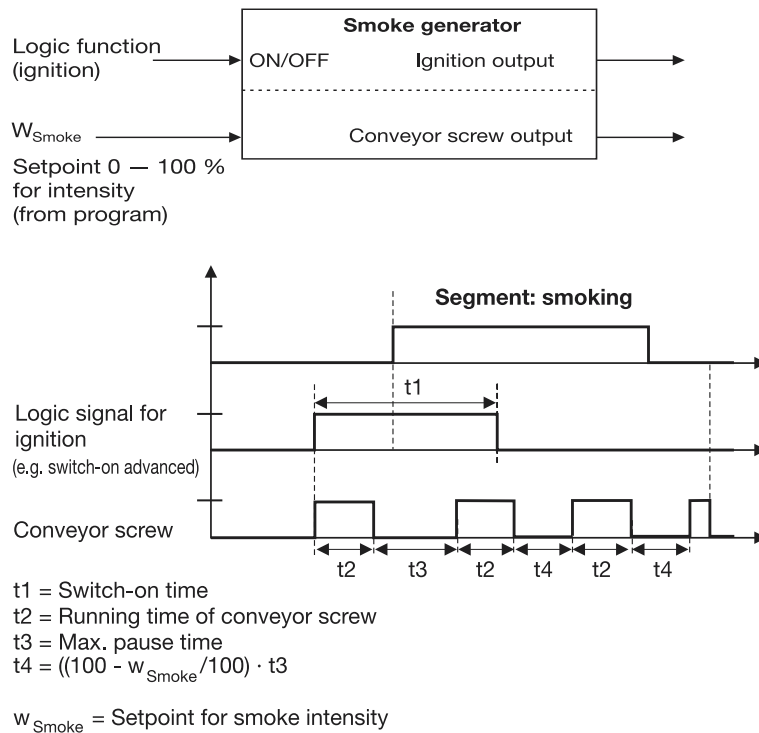

Configuration

- * Assign names to the control functions for operating the smoking and sawdust ignition
Edit → Setup-only settings → Names
- * Define a process step "Smoke"
 - Set values to activate the control functions
 - Define the smoke intensity as a preset value, if such a parameter is to be used
- * Assign the logic outputs for "Smoke generator ignition" and "Intensity, smoke generator 1" and the setting for the ignition time

7.6 User data

7.6.1 Screen saver

To save the screen, the graphics display can be switched off after a preset time without any user action, or by a control signal.

	Selection/settings	Description
	Continuous operation	
from	00:00:00 — 23:59:59 05:30:00	The time for which the screen remains switched on.
to	00:00:00 — 23:59:59 16:00:00	
	Switch-off	
Switch-off event	Waiting time Control signal	The screen is switched off after a preset waiting time following the last key stroke, or by a control signal.
Waiting time	0 — 32767 min	
Control signal	(Logic selector) OFF	

■ / bold = factory setting

7.6.2 Instrument data

Various settings for the basic operation of the instrument are made here.

	Selection/settings	Description
Device designation	(max. 16 characters) IMAGO F3000	Name of the instrument, as used for the data sets in the protocol.
Language	German English French	The language used for operating the instrument.
Program selection	Program icon Program name	Defines the presentation of the program selection on the instrument.
Unit	°C °F	The dimensional unit for all temperature values
Frequency	50Hz 60Hz	Supply power frequency
	Passwords	
Password for configuration	(4-digit numerical code) 9200	Access code for the configuration level
Password for parameterization	(4-digit numerical code) 9200	Access code for the parameter level
	Summer time	
Changeover	OFF Manual Automatic	Defines how the changeover to/from summer time is to be carried out.
Start : date	DD.MM.YYYY 25.03.2001	Date for automatically changing over to summer time
Start : time	00:00:00 — 23:59:59 02:00:00	Time for automatically changing over to summer time

■ / bold = factory setting

7 Setup Program

	Selection/settings	Description
End : date	DD.MM.YYYY	Date for automatically changing back from summer time
	28.10.2001	
End : time	00:00:00 – 23:59:59	Time for automatically changing back from summer time
	03:00:00	

■ / bold = factory setting

7.7 Setup-only settings

7.7.1 7-segment displays

The values which are displayed on the four 7-segment displays can be configured.

Display 1 – 4

	Selection/settings	Description
Display 1 – 3	(Analog selector)	The values which can be displayed in the displays 1 – 3.
	Analog input 1 ¹	
	Analog input 3 ²	
	Relative humidity ³	
Display 4	Remaining segment time	Time remaining until the end of the segment
	Program run-time	Time since the start of the program
	Remaining program time	Time remaining until the end of the program
		Since not all the program segments are under time-control, it is not possible to give a 100% precise value for the remaining program time. The complete (remaining) program time is derived by using the previous run of the program as a reference.

■ / bold = factory setting

1. factory setting for display 1
2. factory setting for display 2
3. factory setting for display 3

7.7.2 Function keys

The 12 freely assignable function keys can be assigned to various control and display functions.

Function	Description
No function	The key does not have a function.
Next segment	In automatic operation: the program continues from the next segment (entry on the instrument).
Previous segment	In automatic operation: the program goes back to the previous segment (entry on the instrument).
Previous program	Starts the last program that was run previously, from the basic status.
Process step	Calls up the current process step.

7 Setup Program

Function	Description
Toggle relay 01 – 35	The switching state of a relay can be changed by hand (manual toggle). If the relay is already ON it is switched off. If the relay is already OFF it is switched on. The resulting state remains valid until the change to the next segment, whereupon the relay takes up the state defined in the next process step.
Temporary alteration: Extra SP1	Temporary extra setpoints
Temporary alteration: Extra SP2	
Temporary alteration: F-value	Temporary F-value
Temporary alteration: C-value	Temporary C-value
Temporary alteration: DeltaT	Temporary Delta T value
Temporary alteration: chamber	Temporary chamber setpoint
Temporary alteration: humidity	Temporary humidity setpoint
Temporary alteration: core	Temporary core setpoint
Program pause	Program pause/continue
Manual operation	Changeover to manual operation Standard setting: timebase is stopped. See Chapter 7.4.6 “Program source” → Extended → Switch off all outputs for program pause
Temp. alt. remaining seg. time	Remaining program time
Start program 1 – 25	Program start
Set/reset markers 1 – 4	This function can be used to set/reset markers, e.g. in logic functions. See Chapter 7.4.6 “Program source” → Expanded → Outputs and markers

Factory settings for keys 1 – 12

Key	Function
1	Temporary alteration: chamber
2	Previous program
3	Previous segment
4	Next segment
5	Temporary alteration: humidity
6	Program pause

Key	Function
7	Process step
8	Manual operation
9	Temporary alteration: core
10	Start PGM1
11	Start PGM2
12	Start PGM3

7 Setup Program

7.7.3 Texts

User texts Up to 100 texts can be defined here, and then displayed on the instrument when various events occur.

System texts The system texts, which are used to guide the user on screen, can be altered here according to user requirements.

7.7.4 Names

Designations can be defined here for

- Control contacts
- Relay outputs
- Logic inputs
- Analog inputs
- Analog outputs
- Markers

to correspond to their functions. These names appear in the various selection lists in the setup program, and make configuration easier. The names can be up to 16 characters long.

7.7.5 Analog outputs



Here you can define the signals that are given out on the (max.) four analog outputs, and the response to overrange/underrange.

Analog output 1 – 4

	Selection/settings	Description
Function	(Analog selector) Analog input 1 Analog input 2 Analog input 3 Analog input 4	The value which is to be presented at the analog output.
Output signal	0 – 10V 2 – 10V 0 – 20mA 4 – 20mA	The electrical signal on the output.

■ / bold = factory setting

7 Setup Program

	Selection/settings	Description
Zero point End value	-1999 to 0 to +9999	The range of values for an output variable is assigned to an electrical output signal. Example: An analog output (0 – 20mA) is to be used to give out setpoint 1 (range of values: 150 – 500°C) i.e. 150 – 500°C corresponds to 0 – 20mA, Zero point: 150 / End value: 500
	-1999 to 100 to +9999	
	 For a proportional controller using direct action, the setting 0 ... 100 must be maintained!	 Setting a controller output for cooling. With proportional controllers using direct action for cooling (or double-setpoint controllers), the settings must be made as follows: Zero point: 0 / End value: -100
Offset	-1999 to 0 to +9999	A constant shift that is applied to all the analog output values.
Overrange/underrange	Accept the present value	The last value is given out continuously.
	Value entry	0 – 100: fixed value is given out

■ / bold = factory setting

7.7.6 Assignment of the relay outputs

Here you can assign specific functions to the logic outputs that are available on the instrument (max. 40).

Relay output 1 – 20

Function	Selection/settings	Description
	Switched off	All the functions described can be assigned to a relay output.
	Logic input 1 – 5	
	Control contact 1 – 36	
	Limit comparator 1 – 8	
	Logic 1 – 8	
	Output 1, controller 1 – 4	
	Output 2, controller 1 – 4	
	Program end signal	
	Fan stage 1 – 3	
	Ignition, smoke generator 1 – 2	
	Intensity, smoke generator 1	
	Ext. logic input 1 – 4 (interface)	
	Humidity control	
	Combined alarm	
	Active	
	Inactive	
	Logic 9 – 16	
	Logic delay 1 – 8	
	Markers 1 – 4	
	Operating modes	
	Reserve 1 – 15	
		Manual, automatic, pause

■ / bold = factory setting

7 Setup Program

	Selection/settings	Description
Timing	No timing	Time delay: The ON and OFF switching transitions (edges) can be delayed for a specified time.
	Time delay	Pulse time: The output can be operated in a specified pulse/pause ratio.
	Pulse time	Timing cannot be defined for control contacts and controller outputs.
Time ON	0 – 32000sec	Delay for transition to ON, or pulse time
Time OFF	0 – 32000sec	Delay for transition to OFF, or pause time

■ / bold = factory setting

7.7.7 Logic and alarm functions

Logic signals or a probe break can trigger various events and messages which are defined here.

The following signals can be assigned to logic and alarm functions:

- Probe break
- Logic inputs
- Limit comparators
- Logic modules
- Control contacts
- Others (program end, program lock, equipment/operating hours counter)

	Selection/settings	Description
Function	No function	The event that is to be triggered
	Keypad lock	Door contact: Timebase on hold, all relays OFF, analog outputs = 0
	Keypad lock, except Start/Stop	
	Lock configuration	
	Lock process steps	
	Lock programs	
	Program start	
	Program stop	
	Cancel program	
	Next segment	
	Previous segment	
	Door contact	
	Program standstill	

■ / bold = factory setting

7 Setup Program

	Selection/settings	Description
Text	Standard text	The text to be displayed on the screen.
	Text 1 – 100	Standard text:
	No text	An appropriate text that is stored in the instrument Text 1 – 100: Freely defined user texts, system texts * Change to menu item “User texts” with (...)
Delay	0 – 9999 sec	A message or alarm is generated after a delay (in seconds).
Message	(active)	A message is generated.
	(inactive)	
Alarm	(active)	An alarm message is generated.
	(inactive)	

■ / bold = factory setting

Where are alarms and messages displayed?

Alarms (with a red bell) and information messages (with an “i”) are displayed in the bottom line of the screen.

Alarms have a higher priority than messages, and the alarm message will only disappear when it has been acknowledged.

Messages disappear automatically as soon as the condition that triggered the messages no longer exists.

5 message types:

- 1.) Immediate message: just click on the message button
- 2.) Delayed message: click on the message button and enter the delay time
- 3.) Immediate alarm: just click on the alarm button
- 4.) Delayed alarm: click on the alarm button and enter the delay time
- 5.) Message turning into an alarm after a delay:
click on both the message and alarm buttons, and enter the delay.

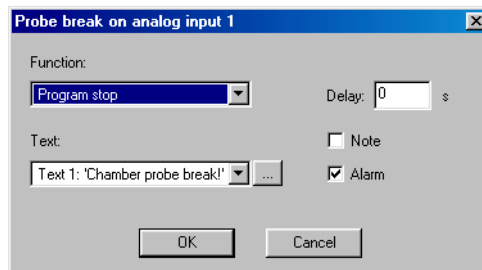

7 Setup Program

Priorities

The alarm or message shown is always the one with the highest priority.

System messages	Message text	Comment	Priority
are displayed like alarms, and cannot be configured	STANDSTILL		 <p>high</p> <p>low</p>
	CALIB-MODE ACTIVE	Calibration mode is ON	
	IO-BOARD NOT CALIB.	I/O board is plugged in, but not calibrated	
	MATH ERROR1	Infringement of mathematical rules triggers an alarm e.g. division by 0	
	MATH ERROR2		
	MATH ERROR3		
	MATH ERROR4		
	LOGIC ERROR1 – 8	Logic module triggers an alarm	
	RESET TIME	Time is not set correctly	
RESTART ERROR3	Checksum error in the data on restart, (for instance, after a power interruption).		

Logic functions	Message text	Comment	Priority
Texts for alarms or messages are configurable in the setup program	RANGE ERROR E.1 – 8	Overrange or underrange, probe break	 <p>high</p> <p>low</p>
	Logic input 1 – 32	Logic inputs trigger an alarm or message text.	
	Limit comp1 – 8	Limit comparator triggers an alarm or message text.	
	Logic1 – 8	Logic module triggers an alarm or message text.	
	Ctrl. contact 1 – 36	Control contacts trigger an alarm or message text.	
	Program end	Signal for program end triggers an alarm or message text.	
	Program lock		
	Equipment hours		

7.7.8 Fan control

The speed control and the response to speed changes are defined here for a fan with up to 3 stages.

Selection/settings	Description
Fan control	
OFF	The function is switched on or off here.
ON	
Run-up time	
0 – 9999sec	Defines the time for the fan to run at stage 2 when the speed is increased.
Run-down time	
0 – 9999sec	Defines the time during which the fan is switched off when the speed is reduced.
Activate stage 1 – 3	
Switched off (Logic selector)	Signal to control the fan speed.

■ / bold = factory setting

Timing

The fan control follows the given speed stages in the segments (through control contacts), taking into account the run-up and run-down times.

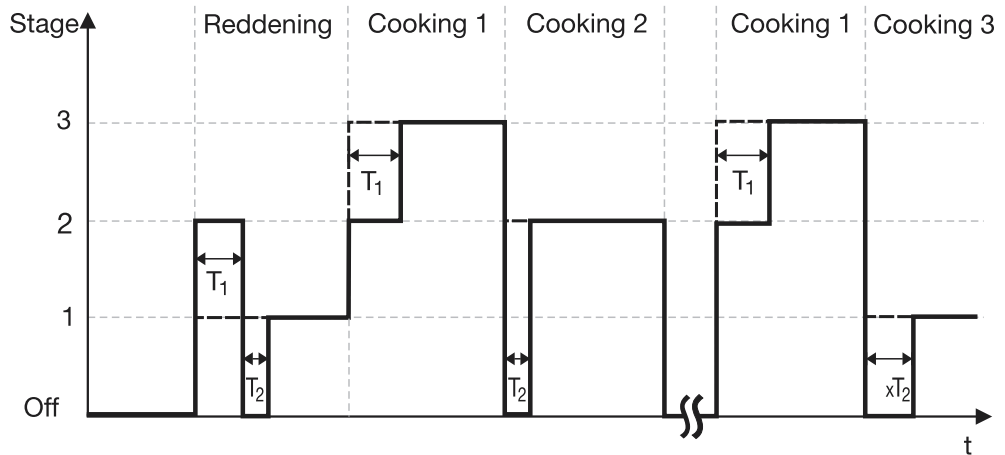

T_1 = Run-up time — = Fan speed control

T_2 = Run-down time - - - - = Setting for fan stage in process step

2-stage fan

For 2-stage fans, the lower speed should be defined as stage 2, and the higher speed as stage 3. The behavior will then be analog to that above (activate stage 1 = switch off).

If several inputs have a simultaneous influence on the fan control function, then the output is the highest stage for the fan speed.

If, for instance, stages 1 and 2 are simultaneously activated by inputs, then only the output for stage 2 will be activated.

7 Setup Program

7.7.9 Math/logic

Four mathematical functions and eight logical formulae can be defined.

Math 1 – 4

	Selection/settings	Description
Function	No function	Difference, ratio and humidity calculation A formula can be entered in the line provided for this purpose, or via the formula editor.
	Difference (a - b)	
	Ratio (a/b)	
	Humidity	
Variable a Variable b	(Analog selector)	Variables for difference, ratio and humidity calculation
	Switched off	
Measurement range restriction		
Start	-1999 to +9999	An alarm message is generated if the result of the calculation lies outside the restricted range of measurement.
End	-1999 to +9999	

■ / bold = factory setting

Humidity

A psychrometric humidity sensor is used to calculate the relative humidity, via the mathematical combination of the wet and dry temperatures.

Formula entry

- The string for the formula consists of ASCII characters, and has a maximum length of 70 characters.
- A formula can only be entered in the setup program.
- The formulae can be freely entered according to normal mathematical rules.
- Any number of space characters may be used within the formula character string. No spaces are permitted within function designations, variable names or constants.
- The maximum calculation time must not be longer than 12 seconds. If this time is exceeded, the setup program will generate an error message.

Math symbols and functions

Priority	Math elements/functions	Comment
high	()	Brackets
	SQRT, MIN, MAX, LOG, LN, SIN, COS, TAN, ABS, EXP, INT, FRC	Functions
	**	Exponential (x ^y)
	+, -	Sign
	*, /	Multiplication, division
low	+, -	Addition, subtraction

Math variables

Variable name	Comment
E1 – E8	Analog input 1 to analog input 8
XRF	Relative humidity
XKE	Core temperature

7 Setup Program

Variable name	Comment
XF	X F-value
XC	X C-value
WK	W chamber
WKA	W chamber A
WF	W humidity
WFR	W humidity pulse time
WKE	W core
WDT	W Delta T
WF	W F-value
WC	W C-value
WR	W intensity, smoke generator 1
WZ1 – WZ2	W additional 1 ... W additional 2
WV1 – WV5	W process step 1 ... W process step 5
M1 – M4	Math output 1 ... math output 4
XW1 – XW4	Control deviation 1 ... control deviation 4
YH1 – YH4	Outp. 1, controller 1 (analog) ... Outp. 1, controller 4 (analog)
YK1 – YK4	Outp. 2, controller 1 (analog) ... Outp. 2, controller 4 (analog)
Y1 – Y4	Output level display cntrl. 1 ... output level display cntrl. 4
VS	Present process step
PGM	Present program number
ASH	Present segment number
EW1	Ext. setpoint 1...4 (interface)
RA1	Reserve A1 ... A10
TAR	Remaining segment time
WTA	Segment runtime
TP	Program runtime
TPR	Remaining program time

Formula variables

Formula variables

Variable name	Comment
B1 – B32	Logic input 1 ... 32
SK1 – SK36	Control contact 1 ... 36
LK1 – LK8	Limit comparator 1 ... 8
L1 – L16	Logic output 1 ... 16
YSH1 – YSH4	Output 1, cntrl. 1 (switching) ... output 1, cntrl. 4 (switching)
YSK1 – YSK4	Output 2, cntrl. 1 (switching) ... output 2, cntrl. 4 (switching)
PEND	Program end signal
FAN1 – FAN3	Fan stage 1 ... fan stage 3

7 Setup Program

ZR1 – ZR2	Ignition, smoke 1 to ignition, smoke 2
IR	Intensity, smoke generator
EB1 – EB4	Ext. binary logic input 1 ... ext. binary logic input 4
FS	Humidity control
SA	Combined alarm
TRUE	Active
FALSE	Inactive
RB1 – RB15	Reserve Logic 1 ... 15
AUTO, HAND, PAUSE	Operating modes: automatic, manual, pause
D1 – D8	Logic delay 1 ... 8
IM1 – 4	Internal markers 1 ... 4

Functions

Syntax	Function
SQRT(a)	Square root of a Examples: SQRT(E2) SQRT(13.5+E3)
MIN (a1, a2 ...)	Finds the lowest value in a string of arguments Examples: MIN(3, 7) (returns the value 3) MIN(E1, E2, E3, 0.1)
MAX (a1, a2 ...)	Finds the largest value in a string of arguments Examples: MAX(3, 7) (returns the value 7) MAX(E1, E3, E3, 0.1)
LOG(a)	Logarithm to base 10 Examples: LOG(1000) (returns the value 3) LOG(E1/100)
LN(a)	Logarithm to base e Examples: LN(2.71828128) (returns the value 1) LN(E1/100)
SIN(a)	Sine of a a in degrees (0 – 360°) Examples: SIN(90) (returns the value 1) SIN(E1*360/100)
COS(a)	Cosine of a a in degrees (0 – 360°) Examples: COS(180) (returns the value -1) COS (E1*360/100)
TAN(a)	Tangent of a a in degrees (0 – 360°) Examples: TAN(45) (returns the value 1) TAN(E1*45/100)
ABS(a)	Absolute value of a a in degrees (0 – 360°) Examples: ABS(-12) (returns the value 12) ABS(13.5+E3)

7 Setup Program

Syntax	Function
EXP(a)	Exponential function e^a Examples: EXP(1) (returns the value 2.718) EXP(E1/100)
INT(a)	Integer portion of a Examples: INT(8.3) (returns the value 8) INT(E1)
FRC(a)	Decimal portion of a Examples: FRC(8.3) (returns the value 0.3) FRC(E1)

Logic 1 – 16

Formula entry

- The string for the formula consists of ASCII characters, and has a maximum length of 70 characters.
- A formula can only be entered in the setup program.
- The formulae can be freely entered according to normal mathematical rules.
- Any number of space characters may be used within the formula character string. No spaces are permitted within function designations, variable names or constants.
- The maximum calculation time for all 8 logic formulae must not be longer than 12 seconds. If this time is exceeded, the setup program will generate an error message.



If the functions *Next* or *Previous segment* are to be triggered via logic formulae, then logic functions 1, 2 or 3 must be used. Only these functions are processed at the same time as the program generator function.

Logical operators

Priority	Operator	Comment
high	()	Brackets
	NOT, !	Negation
	AND, &	AND combination
	XOR, ^	Exclusive-OR combination
	low	OR, ;

7 Setup Program

Edge detection

Edge	Comment
/	Variable (e.g. /B1) is only "TRUE" for a rising edge
\	Variable (e.g. \B1) is only "TRUE" for a falling edge

Variables

Variable name	Comment
B1 – B32	Logic input 1 to logic input 32
SK1 – SK36	Control contact 1 to control contact 36
LK1 – LK8	Limit comparator 1 to limit comparator 8
L1 – L16	Logic output 1 to logic output 16
YSH1 – YSH4	Output 1, controller 1 (switching) to output 1, controller 4 (switching)
YSK1 – YSK4	Output 2, controller 1 (switching) to output 2, controller 4 (switching)
PEND	Program end
FAN1 – FAN3	Fan stage 1 to fan stage 3
ZR1 – ZR2	Ignition, smoke 1 to ignition, smoke 2
EB1 – EB4	External logic input 1 to external logic input 4
FS	Humidity control

Constants

Constant name	Comment
TRUE	logical 1
FALSE	logical 0

7.7.10 Software locks

Various operating facilities on the instrument can be inhibited.



These locks can only be removed through the setup program!
It is not possible to do this on the instrument!

The following operating facilities can be locked:

- Keypad
- Keypad, except Start/Stop key
- Editing of programs
- Temporary alterations

7.7.11 Operating hours counter

Two separate operating hours counter/timers are provided in the instrument. The operational time for a connected piece of equipment and the instrument (in automatic operation) can be monitored and restricted.

	Selection/settings	Description
	Equipment	
Input	(Logic selector) Switched off	The start of counting is triggered by a logic signal.
Hours	0 – 32767	The permissible number of operating hours If this number is reached, a message or alarm is generated. ⇒ Chapter 7.7.7 “Logic and alarm functions”
	System	
Permitted operating hours	0 – 32767	0 = switched off
Password	(max. 8 figures) 0	When the permitted number of operating hours has been reached, it is no longer possible to start a program. A message window appears on the screen and requests the entry of the password. When the password has been entered, the instrument carries on functioning as normal.

■ / bold = factory setting

7.7.12 Production data

Production data, if activated are queried and displayed on the instrument every time the program starts (configuration: “Entry type”).

During the queries, texts or numbers can (“optional”) or must (“obligatory”) be entered.

Texts can be entered for 8 displays/queries, each 16 characters long (e.g. operator No. or batch No.).

These data can be read out for recording and visualization.

7.7.13 Logic delay

Logic signals can be delayed, and their switching polarity can be reversed.

7 Setup Program

7.7.14 Recording

The recording function permits the visualization of up to 6 analog signals and 3 logic signals. The sources for these signals are defined here.

Enable

The recording function is either already enabled in the factory, or it must be enabled through the setup program, using a license number for which a fee is charged.

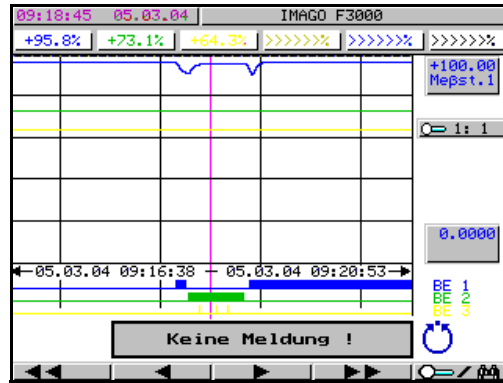

Ring memory

The recorded data are held in a ring memory. As soon as the memory is full, it overwrites the oldest data.

The duration of the recording depends on the sampling interval.

If 6 analog signals and 3 logic signals are sampled per minute, then the recording will run for 12.4 days. If the sampling rate is once per second, then this period will be reduced to about 4.8 hours.

Special situations

If alterations are made to the configuration of the recording function, or the clock settings are altered in the device, then all the data previously stored in the device will be deleted.

7.7.15 Foreign languages

It is possible to integrate various foreign languages, and to transfer them to the device via the setup program.

7.8 Setup data info

This is used for the documentation of various items of information that appear in the print-out of the setup data.



JUMO GmbH & Co. KG

Street address:
Moritz-Juchheim-Straße 1
36039 Fulda, Germany
Delivery address:
Mackenrodtstraße 14
36039 Fulda, Germany
Postal address:
36035 Fulda, Germany
Phone: +49 661 6003-0
Fax: +49 661 6003-607
e-mail: mail@jumo.net
Internet: www.jumo.net

JUMO Instrument Co. Ltd.

JUMO House
Temple Bank, Riverway
Harlow, Essex CM 20 2 TT, UK
Phone: +44 1279 635533
Fax: +44 1279 635262
e-mail: sales@jumo.co.uk
Internet: www.jumo.co.uk

JUMO Process Control, Inc.

8 Technology Boulevard
Canastota, NY 13032, USA
Phone: 315-697-JUMO
1-800-554-JUMO
Fax: 315-697-5867
e-mail: info@jumo.us
Internet: www.jumo.us