

JUMO IPC 300

Electronic Transformer



709061/8-01-200-00/...

Operating manual

70905100T90Z001K000



V2.00/EN/00741192/2023-06-30



All parameter settings are described in detail in the chapter "Configuration".

This operating overview shows all possible parameters of the device series.

Depending on the order specifications or current configuration, any parameters that are not required are hidden.

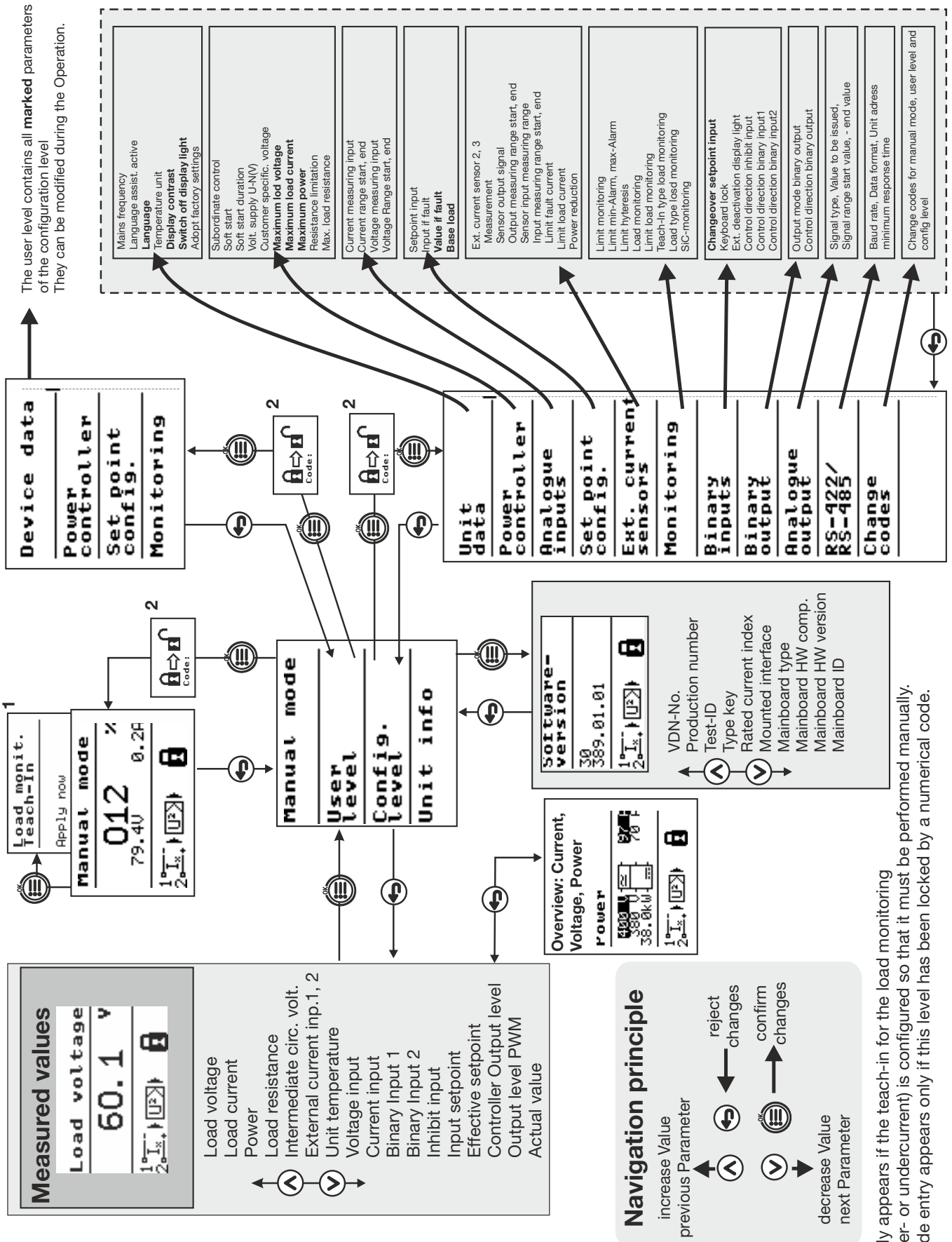

1. Only appears if the teach-in for the load monitoring (over- or undercurrent) is configured so that it must be performed manually.
2. Code entry appears only if this level has been locked by a numerical code.

1	Introduction	9
1.1	Intended use	9
1.2	Safety information	10
1.2.1	Warning symbols	10
1.2.2	Note symbols	10
1.2.3	Performing an action	11
1.2.4	Display types	11
1.3	Order details	12
1.3.1	Scope of delivery	12
1.4	Necessary system components	12
1.4.1	Choke for type 709051/X-XX-070-XX/XXX	12
1.4.2	Choke for type 709051/X-XX-100-XX/XXX	13
1.4.3	Choke for type 709051/X-XX-200-XX/XXX	13
1.4.4	EMI filter for all types 709051/X-XX-XXX-XX/XXX	13
1.5	Accessories	14
1.6	Brief description	14
2	Mounting	15
2.1	Important installation notes	15
2.1.1	Correct wiring of all components	16
2.2	Filtering and interference suppression	18
2.2.1	EMC-compliant design	20
2.3	Environmental influences	21
2.3.1	Admissible load current depending on the site altitude	22
2.3.2	Wall mounting	23
2.4	Dimensions	24
2.4.1	Type 709051/X-XX-070... or 709051/X-XX-100...	24
2.4.2	Type 709051/X-XX-200...	25
2.4.3	Clearances (all types)	25
3	Electrical connection	27
3.1	Screw connections in the power section	27
3.1.1	Type 709051/X-XX-070... or 709051/X-XX-100...	27

Contents

3.1.2	Type 709051/X-XX-200...	28
3.2	Screw terminals for control electronics	29
3.3	Connection diagram	30
3.3.1	Power section	30
3.3.2	Control electronics	30
3.3.3	Digital output	32
3.3.4	Interfaces (option)	32
3.3.5	Suitable lines and cross-sections	33
3.3.6	Calculation of the EMI filter current	34
3.3.7	Galvanic isolation	35
3.3.8	Use of residual current protection devices	36
3.4	Switch-on sequence	36
3.4.1	Single-phase operation: phase / N	37
3.4.2	Single-phase operation Phase / Phase	38
3.4.3	Replacing the two semiconductor fuses	39
4	Operation	41
4.1	Display after switching on the device	41
4.1.1	Display and control elements	42
4.1.2	Appearance of measured values	42
4.1.3	Meaning of the displayed measured values	43
4.1.4	Appearance of error messages and special statuses	44
4.2	User level	44
4.2.1	Device data	45
4.2.2	Power controller	45
4.2.3	Setpoint value configuration	46
4.2.4	Monitoring	46
4.2.5	Binary inputs	47
5	Configuration	49
5.1	Configuration level	49
5.1.1	Unit data	50
	Language wizard active	50
	Temperature unit	50
	Display contrast	50

Switch-off.....	50
display lighting	50
Apply default settings	50
5.1.2 Power controller	51
Subordinate control loop	51
Soft start	51
Soft start duration	51
Voltage supply U-N(V).....	51
Customer-spec. voltage	51
Max. load voltage	51
.....	51
5.1.3 Analog inputs	52
Max. load current.....	52
Resistance limitation.....	52
Max. load resistance.....	52
Current measuring range	52
Current measuring range, start.....	52
Current measuring range, end	52
Voltage measuring range	52
Voltage measuring range, start.....	53
Voltage measuring range, end	53
5.1.4 Setpoint configuration	53
Setpoint specification	53
Input in the event of an error.....	53
Value in the event of an error.....	53
Base load	54
5.1.5 Ext. current sensor 2 and 3	54
Measurand.....	54
5.1.6 Monitoring	55
Min. alarm limit value	55
Max. alarm limit value	55
Limit value hysteresis.....	55
Load type load monitoring	56
Teach-In type load monitoring.....	56
5.1.7 Binary inputs	57
External changeover of setpoint specification.....	57
Setpoint specification for changeover	57
Setpoint value for changeover	57
Keypad locking	57
External switch-off of display lighting.....	57
Inhibit input control direction	57
Control direction,	

Contents

digital input1	57
Control direction, digital input2	58
5.1.8 Binary output	58
Output mode.....	58
Control direction, digital output.....	59
5.1.9 Analog output	60
Signal type	60
Value to be output	60
Signal range start value	60
Signal range end value	60
5.1.10 RS422/485	60
Baud rate	60
Data format	60
Device address	60
Min response time	61
5.1.11 Change codes	61
Code, manual mode	61
Code, operation level.....	61
Code, config. level.....	61
6 Special device functions	63
6.1 Subordinate control loop	63
6.2 Detection of load faults	63
6.2.1 Teach-In	66
6.3 Manual mode	67
6.3.1 Setpoint specification in manual mode	67
6.3.2 Configuring Teach-In (prerequisite for Teach-In in manual mode)	67
6.3.3 Performing Teach-In in manual mode	68
6.4 Setpoint specification via potentiometer	69
6.5 Resistance limitation (r-control)	70
6.6 Current limiting	71
6.7 Firing pulse inhibit	71
6.8 External current sensors	72
6.8.1 Error current	72
6.8.2 Load monitoring	73
6.8.3 Mains current	75

7	Setup program	77
7.1	Hardware	77
7.2	Compatible operating systems	77
7.3	Program start	78
8	Error messages and alarms	79
8.1	Binary signal for collective fault	83
9	What to do, if	85
10	Technical data.....	87
10.1	Voltage supply, load current	87
10.2	Analog inputs	87
10.3	Analog output	87
10.3.1	Display and measuring accuracy	87
10.4	Digital inputs	88
10.5	Digital output	88
10.6	General specifications	88
11	Certificate	91
11.1	China RoHS	91







Contents

1.1 Intended use



Read this operating manual before putting the device into service.

This operating manual is valid from **device software version** [389.01.01].

Software- version
389.01.01
1.      

Keep the operating manual in a place that is accessible to all users at all times.

The device is designed for use in an industrial environment as specified in the technical data. Other uses beyond those defined are not viewed as intended uses.

The device has been manufactured in compliance with applicable standards and directives as well as the applicable safety regulations. Nevertheless, improper use may lead to personal injury or material damage.

To avoid danger, only use the device:

- For the intended use
- When in good order and condition
- When taking the technical documentation provided into account

Risks resulting from the application may arise, e.g. as the result of missing safety provisions or wrong settings, even when the device is used properly and as intended.



Separate safety switch-off required

The power controller produces the power that is needed at the analog input or in manual mode. Safety systems independent of the power controller must be installed. They should safely switch off the subsequent heating process in the event of excess temperatures.



The power controller may only be operated using **original JUMO semiconductor fuses**.

In the event of replacement, please check that the correct spare part has been used.

All necessary settings are described in this operating manual.

Manipulations not described in the operating manual or expressly forbidden will jeopardize your warranty rights.

If you have any problems, please contact the nearest branch office or the head office.



When accessing the inner parts of the device and returning device plug-in units, modules, or components, please observe the regulations according to DIN EN 61340-5-1 and DIN EN 61340-5-2 "Protection of electronic devices from electrostatic phenomena". Use only **ESD** packaging for shipment.

Please note that we cannot accept any liability for damage caused by ESD.

ESD=Electrostatic Discharge

1 Introduction

1.2 Safety information

1.2.1 Warning symbols

Caution



This symbol in connection with the signal word indicates that **material damage** or **data loss** will occur if the respective precautionary measures are not taken.

Danger



This symbol indicates that **personal injury** from electrocution may occur if the appropriate precautionary measures are not taken.

ESD



This character is used if precautionary measures must be taken when handling **electrostatically sensitive components**.

Dangerous voltage



This symbol is used if dangerous voltages will cause an electric shock in the event of contact with live parts.

Hot surface, fire hazard



This symbol is used if burns can result from touching a hot surface.



Do not install any heat-sensitive components or devices close to the power controller.

1.2.2 Note symbols

Note



This symbol is used to draw your attention to a **particular issue**.

Reference



This symbol refers to **further information** in other manuals, chapters, or sections.

Footnote

abc¹

Footnotes are remarks that **refer to** specific parts of the text. Footnotes consist of two parts:
An identification marking in the text, and the footnote text.
The identification marking in the text is arranged as continuous superscript numbers.

1.2.3 Performing an action

Action instruction, table of steps

* Plug in the connector

This symbol marks the description of a **required action**. The individual steps are marked by this asterisk or by sequential numbers.

Vital text



READ THE DOCUMENTATION!

This symbol, which is attached to the device, indicates that the associated **device documentation must be observed**. This is necessary in order to recognize the nature of the potential danger and take the necessary measures to prevent it.

Command sequence

Config.level → Power controller →
tional language

Na-Small arrows between words are designed to make it easier to find parameters in the configuration level.

1.2.4 Display types

Keys



Keys are displayed as symbols.

Key combinations are represented by a plus sign.

1 Introduction

1.3 Order details

The nameplate is affixed to the right-hand side of the housing.

(1) Basic type	
709051	JUMO IPC 300 with voltage supply to control electronics: DC 24 V, +15 %/ -20 % and voltage supply to power section: AC 400 V, 230 V, or 115 V
(2) Version	
8	Standard with default settings
9	Customer-specific configuration (specifications in plain text)
(3) National language of display texts	
01	German
02	English
03	French
(4) Load current	
070	DC 70A
100	DC 100A
200	DC 200A
(5) Interface	
00	None
54	RS422/485 Modbus RTU
63	PROFINET
(6) Extra codes	
252	Relay (changeover contact)
257	Optocoupler

Order code (1) / (2) - (3) - (4) - (5) / (6)
 / - - - /
Order example 709051 / 8 - 01 - 100 - 54 / 252

1.3.1 Scope of delivery

1 IPC 300 in the ordered version
1 operating manual

1.4 Necessary system components

1.4.1 Choke for type 709051/X-XX-070-XX/XXX

Choke: $L = 0.6\text{mH}/I_N = 75\text{A}$, protection type IP 20, acc. to EN 60529

Dimensions	Connection cross section	Tightening torque for screw terminals	Weight	Part no.
Diameter: 155 mm Height: 135 mm Diameter of fixing hole: 10.4 mm	Via screw terminals up to max. 4 to 25 mm ²	Max. 4 to 4.5 Nm	Approx. 7.5 kg	00392474

1.4.2 Choke for type 709051/X-XX-100-XX/XXX

Choke: $L = 0.6 \text{ mH} / I_N = 100 \text{ A}$, protection type IP 20, acc. to EN 60 529

Dimensions	Connection	Tightening torque for screw terminals	Weight	Part no.
Height: 208 mm Width: 200 x 200 mm	Via screw terminals up to max. 10 to 50 mm ²	Max. 6 to 8 Nm	Approx. 20 kg	00415759

1.4.3 Choke for type 709051/X-XX-200-XX/XXX

Choke: $L = 0.6 \text{ mH} / I_{\text{Nom}} = 200 \text{ A}$, protection type IP 20, acc. to EN 60 529

Dimensions	Connection	Tightening torque for screw terminals	Weight	Part no.
Height: 190 mm Width: 200 x 385 mm	Via screw terminals from 35 to 95 mm ²	Max. 15 to 20 Nm	Approx. 37 kg	00436848

1.4.4 EMI filter for all types 709051/X-XX-XXX-XX/XXX

EMI filter

The maximum current (effective value) which the IPC 300 takes from the voltage supply in the power section determines the size of the filter.

The corresponding graduations can be found in the table.

For voltage supply to power section					
Nominal voltage, Nominal current	Dimensions (L x W x H)	Tightening torque for screw terminals	Weight	Permissible ambient temperature	Part no.
AC 115V/250V/440V, $I_{\text{Nom}} = 16 \text{ A}$	(255 x 60 x 130) mm	0.6 to 0.8 Nm	Approx 4 kg	40 °C	00399527
AC 115V/250V/440V, $I_{\text{Nom}} = 20 \text{ A}$	(289 x 70 x 140) mm	1.5 to 1.8 Nm	Approx. 5.5 kg	40 °C	00438775
AC 115V/250V/440V, $I_{\text{Nom}} = 32 \text{ A}$	(324 x 90 x 160) mm	1.5 to 1.8 Nm	Approx. 9.5 kg	40 °C	00409831
AC 115V/250V/440V, $I_{\text{Nom}} = 63 \text{ A}$	(380 x 117 x 190) mm	2 to 2.3 Nm	Approx 17 kg	40 °C	00409990
AC 115V/250V/440V, $I_{\text{Nom}} = 100 \text{ A}$	(445 x 150 x 220) mm	6 to 8 Nm	Approx. 26 kg	40 °C	00431997

1 Introduction

1.5 Accessories

Item	Part no.
Setup program 709051 (IPC 300)	00752979
USB cable, A connector to Micro-B connector, 3 m	00758212
Semiconductor fuses (2x required): 2 extra-fast semiconductor fuses have been installed in the device to protect the IPC in the event of a ground fault. The I^2t value (operating integral) of the semiconductor fuse must be smaller than 20000 A ² s!	00434229

1.6 Brief description

Device	<p>The JUMO IPC 300 is a power converter for controlling resistive heating loads. Due to its way of operating, the device is also referred to as an electronic transformer with a pulsating direct voltage at the output. The microprocessor controlled power controller displays all parameters in an LCD display with background lighting. It can be operated using the 4 keys at the front. There is no galvanic isolation between the voltage supply of the power section and the load voltage.</p> <p>In addition to the IPC 300 itself, a choke and a mains filter are essential for operation. Here, only the chokes or mains filters that are specified by JUMO may be used.</p> <p>Amplitude control ensures that current consumption is sinusoidal and reduces the phase control reactive power. Synchronous clock pulse control and reactive power compensation are not required.</p>
Advantages	<p>It combines the advantages of a conventional variable AC transformer (such as amplitude control and sinusoidal network load) with the advantages of a thyristor power switch (such as current limiting, load monitoring, subordinate control loop, etc.).</p>
Application	<p>The converter can be used in all application areas where large resistive loads have to be switched and no galvanic isolation between the voltage supply of the power section and the load voltage is required.</p> <p>Due to the amplitude control (mains current consumption is always sinusoidal), synchronous clock controls (for burst-firing operation), and reactive-current compensation devices (due to reactive power with phase-angle operation) are no longer required.</p>

2.1 Important installation notes

Safety regulations

- The choice of cable material, the installation, and the electrical connection of the device must conform to the requirements of VDE 0100 "Regulations on the Installation of Power Circuits with Nominal Voltages below AC 1000 V" or the appropriate local regulations.
- The electrical connection must only be established by qualified personnel.
- An isolating switch should be wired between the voltage supply and the device to be able to disconnect the device from the voltage supply on all poles prior to accessing the inner parts of the device.



Caution!

When working on the device, the voltage supply of the power section must be switched off on all poles.

Allow 1 minute to elapse after disconnecting, prior to starting work on the device, since potentially fatal voltages could be present in the device interior and at the connection terminals.

- Inside the device, safety clearances meet the requirements for double insulation.
When mounting the connection line, ensure that the lines are fitted according to regulations and that the safety clearances are maintained.

Electrical supply types

The IPC 300 is suitable for operation with TN and TT supply networks.

- * Carry out installation in accordance with EN 50178.

Fuse protection



- Fuse protection in accordance with the VDE regulations must be installed for the voltage supply to the power section. The supply can also be protected with a circuit breaker in the supply line. This must be dimensioned for the power consumption of the IPC 300 and the nominal current of the downstream EMI filter.

- 2 semiconductor fuses are incorporated to protect the IPC 300 in the event of a ground fault.
(The I^2t value (operating integral) of the semiconductor fuse must be smaller than 20000 A²s!)

⇒ Chapter 3.4.3 "Replacing the two semiconductor fuses"

- If there is a relay in the device (extra code 252), this must be fuse-protected against the maximum relay current.

2 Mounting

2.1.1 Correct wiring of all components

EMI filter



The IPC 300 may only be used in conjunction with a suitable filter (accessories). If a different filter is used, it must be of equal or better characteristics. Otherwise, inductive voltages may be introduced into the supply network. We decline any liability for damage caused as a result.

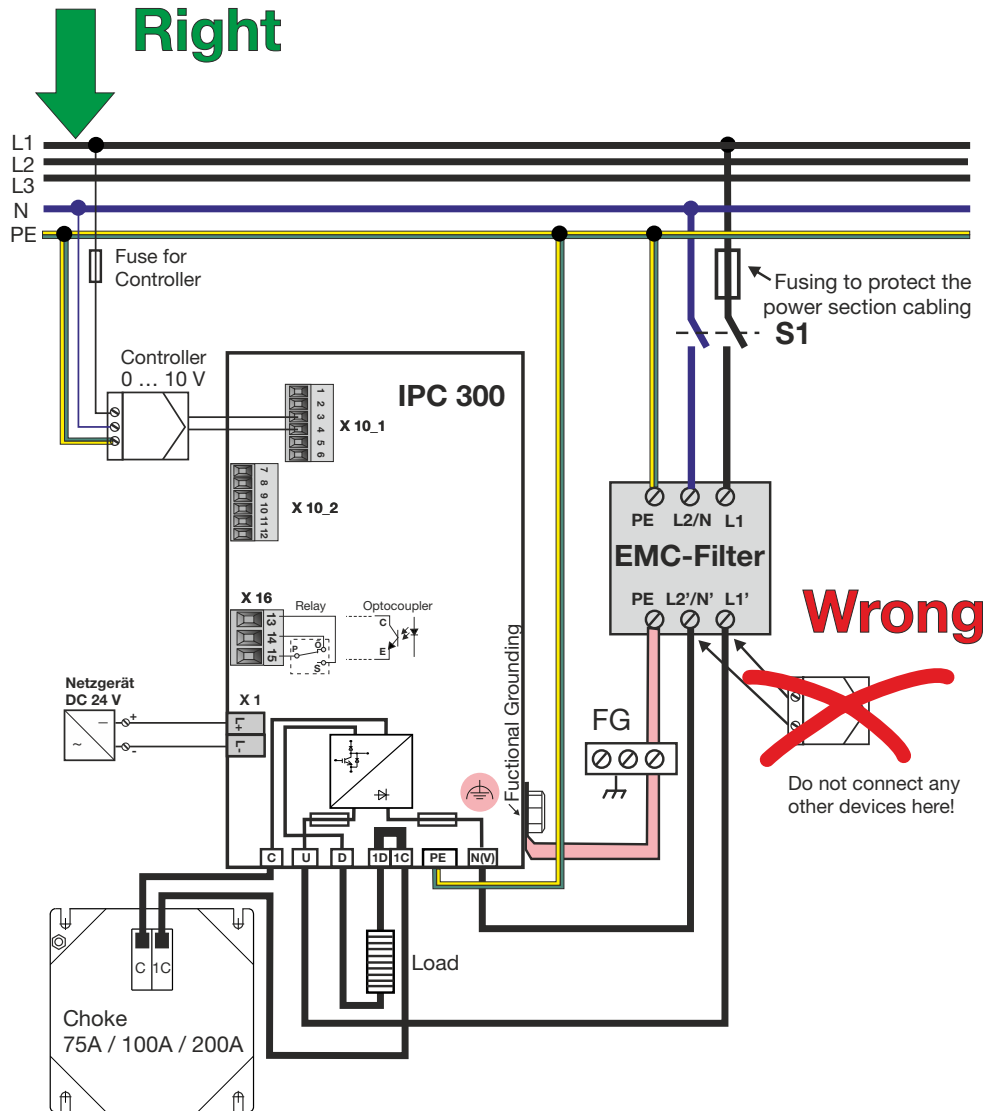

The EMI filters may **only** be used for interference suppression of the IPC 300. Other devices, such as controllers, power supply units etc. must be suppressed, where necessary, with their own EMI filters. **Do not** connect these devices **in parallel to the IPC 300 on the load side** of the EMI filter.

The leakage current of the IPC 300 with upstream mains filter is less than

3 mA. If, due to the load, the leakage current is greater than 3.5 mA, a fixed connection is required for protection against dangerous shock voltages (see also EN 50178).

Electromagnetic compatibility conforms to the standards and regulations cited in the technical data.

⇒ Chapter 10 "Technical data"

* Where possible, load lines and lines for control inputs should be routed so that they are isolated.

Positioning of the choke

* The choke should be installed close to the device.

Connection

* Check the data given on the nameplate (voltage supply to the control electronics, voltage supply to the power section, load voltage, and load current) against the system data.

⇒ Chapter 1.3 "Order details"

* Check the adaptation of the setpoint inputs.

PE connection/ FB connection

* A direct protection conductor connection must be provided between the IPC and the PE conductor of the supply network. Connect to the PE connection terminal of the IPC 300.

* If necessary, interference emission of the IPC 300 can also be minimized by function equipotential bonding. The function equipotential bonding is connected to the FB connection terminal of the IPC 300.

⇒ Chapter 2.1.1 "Correct wiring of all components"

Choke connection

* The choke is connected to terminals C and 1C.

Voltage supply

* Connect the voltage supply for the control electronics at terminals L+ and L-.

* Connect the voltage supply of the power section to terminals U and N(V).



An isolation switch must be installed upstream of the power controller to be able to disconnect the device from the mains voltage on all poles prior to starting internal work!

The connection must only be carried out by qualified personnel!

Load connection

* The load is connected to terminals D and 1D.

* The line between the load and the IPC 300 should be as short as possible and not exceed 50 m.

2 Mounting



Use a shielded line to connect to the load; ensure that the shielding is connected to earth on both sides.

- ⇒ Chapter 2.2 "Filtering and interference suppression"
Choosing the suitable line
- ⇒ Chapter 3.3.5 "Suitable lines and cross-sections"

Control inputs

The terminal strip for control connections (inputs and outputs) has been designed for safe isolation from the mains voltage (SELV). To prevent the safe isolation from being impaired, ensure that all connected electrical circuits are also safely isolated. The required auxiliary voltages must be SELV voltages.

Switch-on sequence when using bus systems

When using a bus system, the control electronics of the IPC 300 must be permanently supplied with DC 24 V, in order to maintain the field bus communication. **S1** is used to disconnect the load.

If the voltage supply of the power section is re-activated via **S1**, the IPC 300 performs a soft start (soft start of the load to the desired setpoint value).

- ⇒ Chapter 3.4.1 "Single-phase operation: phase / N" and
Chapter 3.4.2 "Single-phase operation Phase / Phase"

2.2 Filtering and interference suppression

System

Compliance with the EMC standards can only be achieved through additional EMC measures.

These include:

- EMI filter in the supply line of the voltage supply for the power section
- A shielded line to the load
- Function equipotential bonding (FB)

Compliance with the relevant EMC standards must be tested for the overall system.

Structure

To keep interference emission through conducted and radiated interference below the permissible levels defined in the pertinent EMC standards, constructive measures must be taken in the installation and wiring stages in addition to supply input filtering. Poor earth connection of the EMI filter will reduce the effectiveness of the interference suppression measures.

The following points should be noted in order to achieve good configuration for EMC purposes:

- * All metallic components of the device or cabinet must be well bonded for HF currents over a large surface area.
- * The EMI filter should be installed as close to the IPC 300 as possible, on a common metal plate if possible. Route lines for control inputs and signal lines as far apart from each other as possible, and use shielded lines.
- * If possible, do not route power lines in the same cable duct as control or signal lines.
- * The line between the load and the IPC 300 should be as short as possible

and not exceed 50 m.

Ground

The base plate, the mains filter, and the shielding of the supply line must be earthed to a star point using HF strand.

Choosing the suitable line

- If the line between the filter and the IPC 300 is longer than 300 mm, we recommend to use a shielded line with the shielding earthed on both sides. Route cables inside the control cabinet as close as possible to the ground potential, as otherwise they can act as antennae and emit interference.
- To achieve a good shielding effect for the line, only use lines that have shielding made with tin-plated or nickel-plated copper braiding. The coverage of the shielding should be at least 70 %; the lay angle should be 90°. Shielding made of steel braiding is not suitable, however. Ground the shielding of the load line on both sides.
- The shielding of the control input lines must only be grounded at one end (IPC 300 side). If there are differences in potential, an additional potential equalization line must be installed.

2 Mounting

2.2.1 EMC-compliant design

The plant operator is responsible for compliance with EMC directives in the application, and this is shown in the figure below for types 709051/X-XX-XXX-XX/XXX with a **Phase / Phase** connection type.

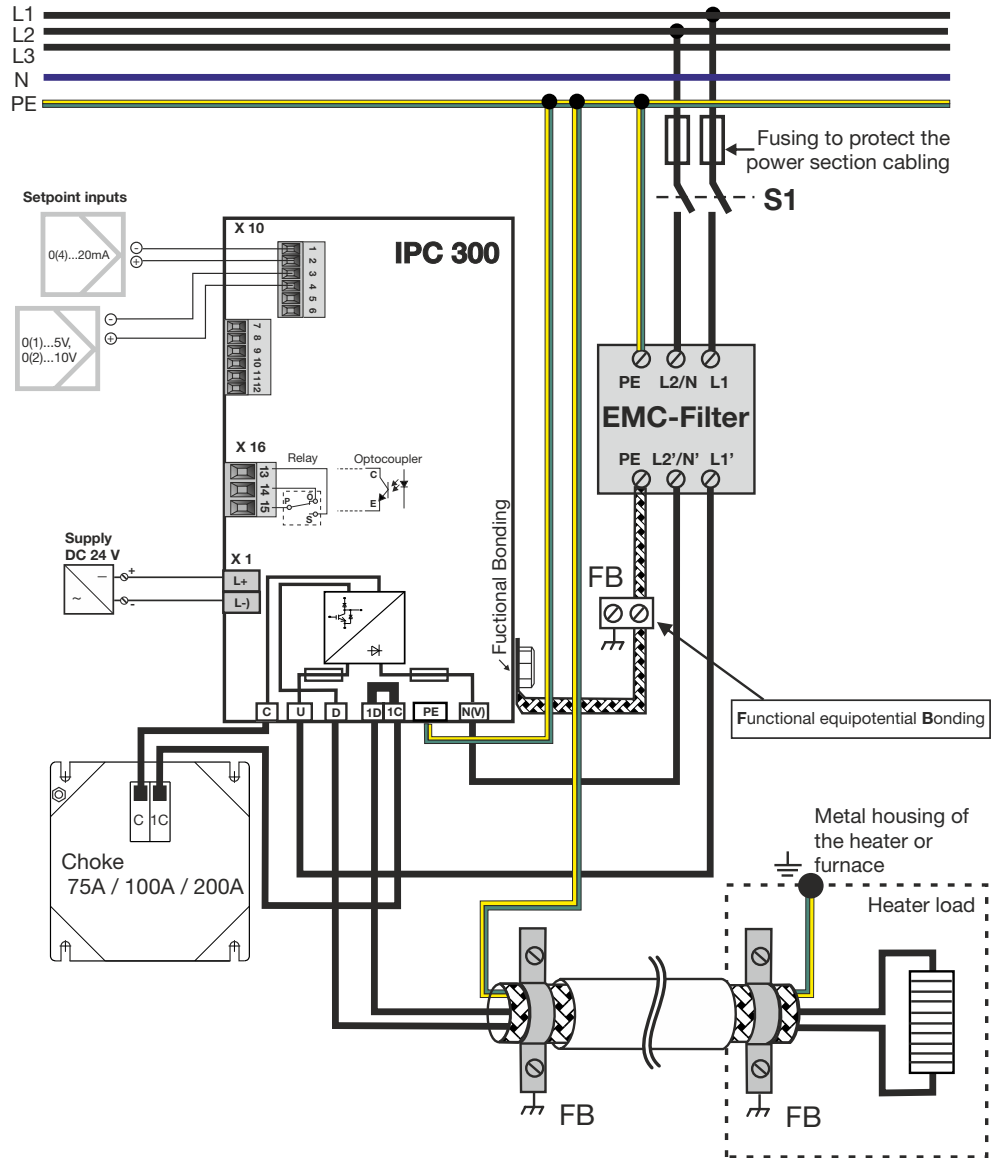

2.3 Environmental influences

- Incorrect use** The device is **not** suitable for installation in potentially explosive areas.
- Mounting site** The mounting site should be free from vibration, dust, and corrosive media. In accordance with the conditions specified in VDE 0660-514, the device is **finger safe** (IP20) and must be installed in a control cabinet.
- Climatic conditions**
- Relative humidity : 5 to 85 %, no condensation (3K3 according to EN 60721)
 - Max. air inlet temperature 35 °C
 - Ambient temperature range: 5 to 40 °C (3K3 according to EN 60721)
 - Storage temperature range: -10 to 70 °C
- Power loss** Power loss occurs in the form of waste heat at the heat sink of the IPC 300, at the mains filter, and choke, and has to be dissipated at the mounting site (e.g. in the control cabinet) in accordance with the climatic conditions.

IPC300 type	Voltage supply for power section	Maximum power loss $P_{Loss\ max.}$	Power loss P_{Loss} of the application
709051/X-XX-070...	400 V	770 W	$P_{Loss} = P_{Loss\ max} \times \frac{I_{Appl.}}{I_{rated}}$ <p> $I_{Appl.}$: Load current of the application I_{rated}: Load current on nameplate P_{Loss}: Power loss (that arises on Filter, Choke and inside IPC 300) </p>
	230 V	450 W	
	115 V	280 W	
709051/X-XX-100...	400 V	1100 W	
	230 V	640 W	
	115 V	400 W	
709051/X-XX-200...	400 V	1740 W	
	230 V	1400 W	
	115 V	960 W	

2 Mounting

2.3.1 Admissible load current depending on the site altitude

Site altitude

In the case of air cooling, it must be noted that the effectiveness of the cooling is reduced as the site altitude increases. As a result, the ampacity of the IPC 300 decreases as the site altitude increases, as shown in the diagram.

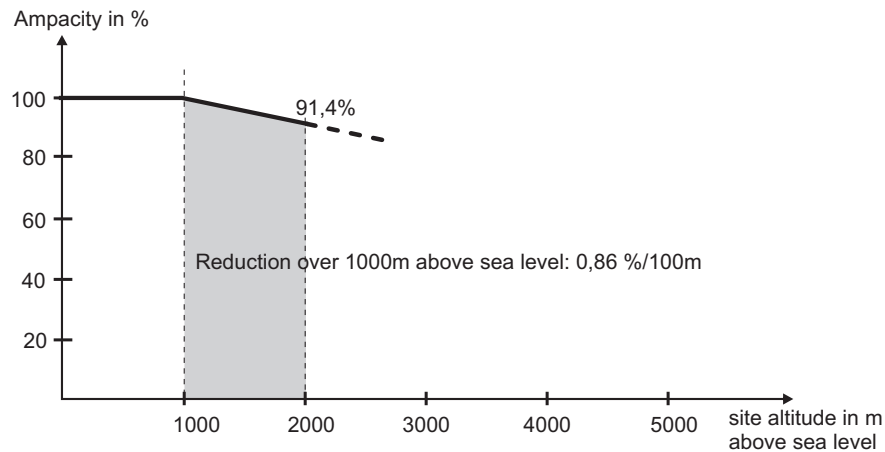

Destruction through overheating:

In the event of operation at maximum load current over an extended period, the heat sink and its surroundings heat up.

The device temperature must not exceed 100 °C.

At a device temperature of >100 °C, the message "Warning - high temperature" is displayed.

At a device temperature of >105 °C, the output level is gradually reduced by 10 % each time the temperature increases by one degree.

At a device temperature of >115 °C, the power controller is completely switched off.

⇒ Chapter 8 "Error messages and alarms"

2.3.2 Wall mounting

Use four M6 hex-headed screws (at least grade 8.8) to fix the device vertically on a temperature-resistant control cabinet back panel.

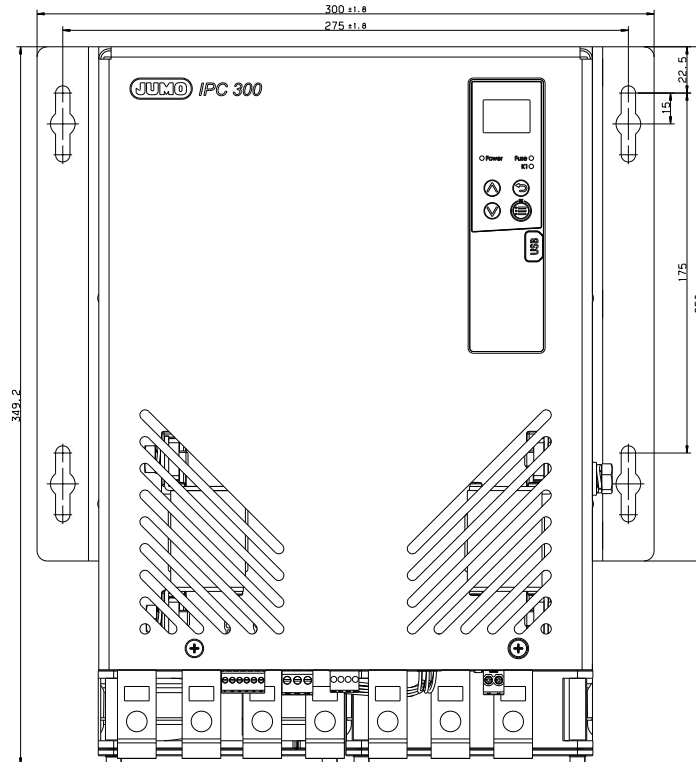

Hot surface



During operation, the power controller may heat up to 110 °C, depending on the load.

Ensure that the lamellae of the heat sink are vertically aligned to allow the heat to be dissipated through natural convection.



Fire hazard:

Do not install any heat-sensitive components or devices close to the power controller.



The intake air at the fan's ventilation grid must not exceed a maximum inlet air temperature of 35° C. Ensure that the intake air for the integrated fans can be taken in from below and escape at the top without obstruction!

2 Mounting

2.4 Dimensions

2.4.1 Type 709051/X-XX-070... or 709051/X-XX-100...

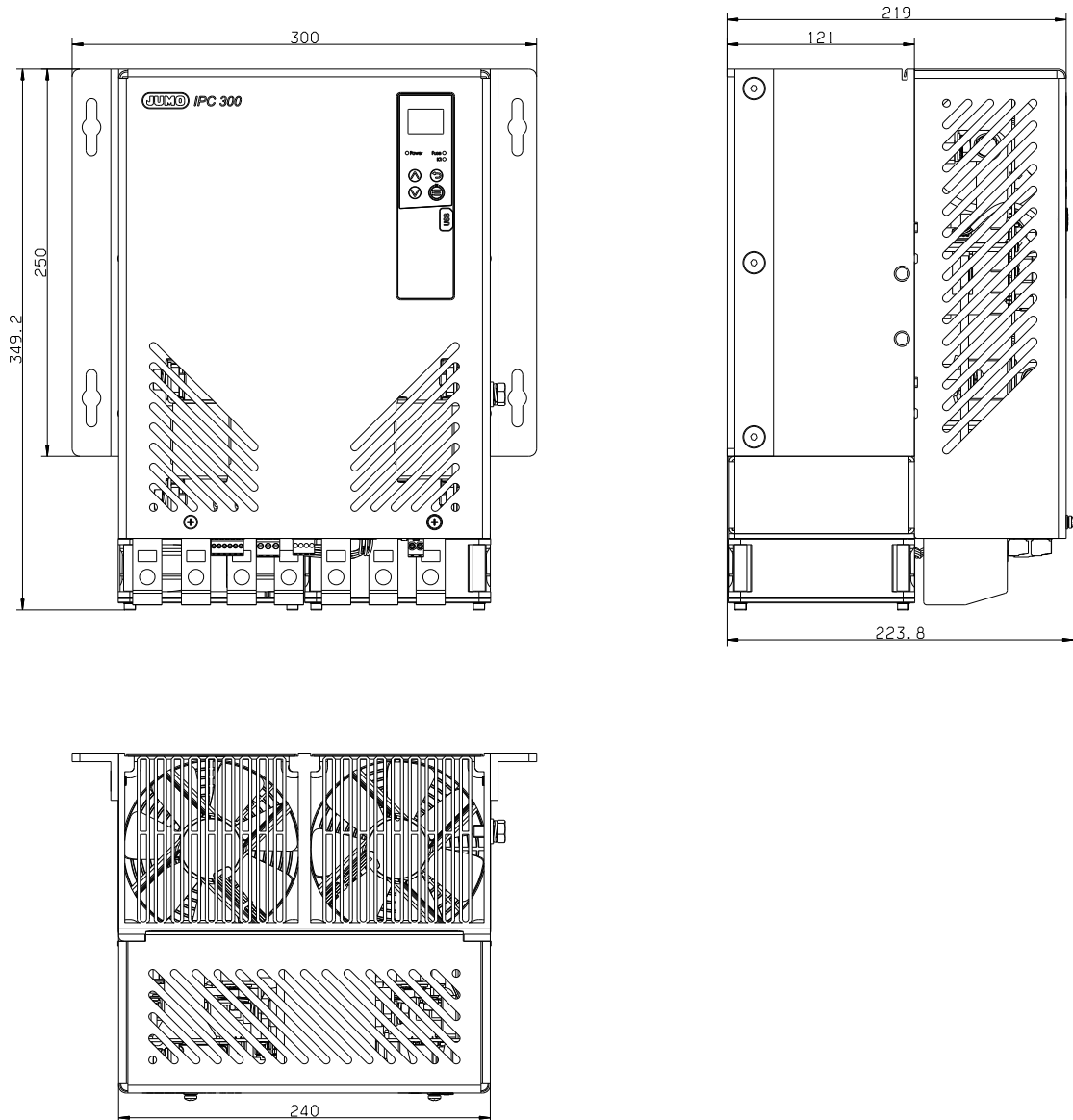

2.4.2 Type 709051/X-XX-200...

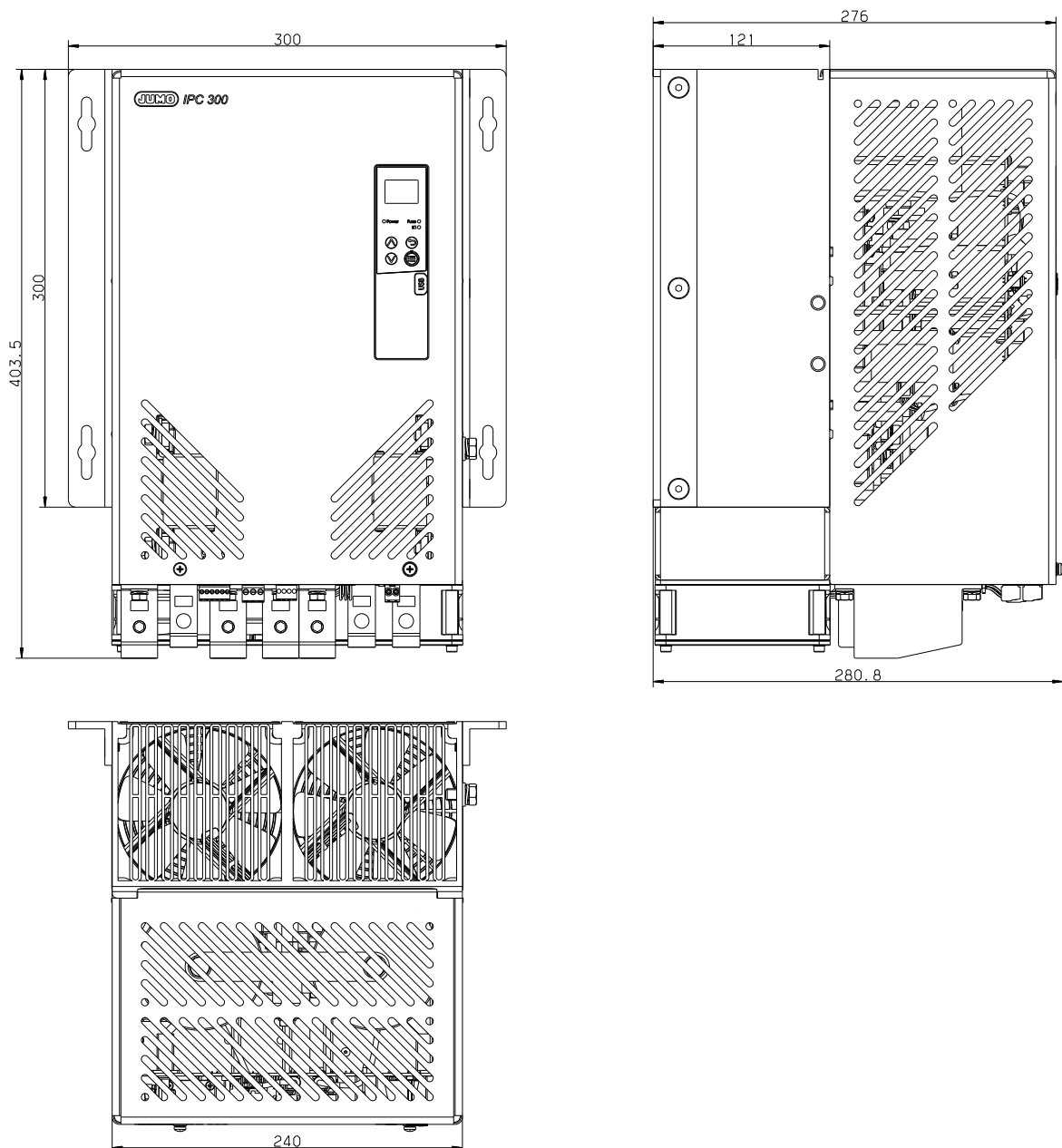

2.4.3 Clearances (all types)

- * Allow a clearance of 10 cm from the floor.
- * Allow a clearance of 15 cm from the ceiling.
- * Close mounting of devices next to each other is permitted.

2 Mounting

3 Electrical connection

Dangerous voltage



The electrical connection must only be carried out by qualified personnel! Dangerous voltages will cause an electric shock in the event of contact with live parts!

* Disconnect the system from the mains voltage on all poles.

All screw terminals supplied ex works must be inserted and screwed tight during operation!

3.1 Screw connections in the power section

- Tools**
- Screwdriver
 - Hex wrench size 5 mm

3.1.1 Type 709051/X-XX-070... or 709051/X-XX-100...

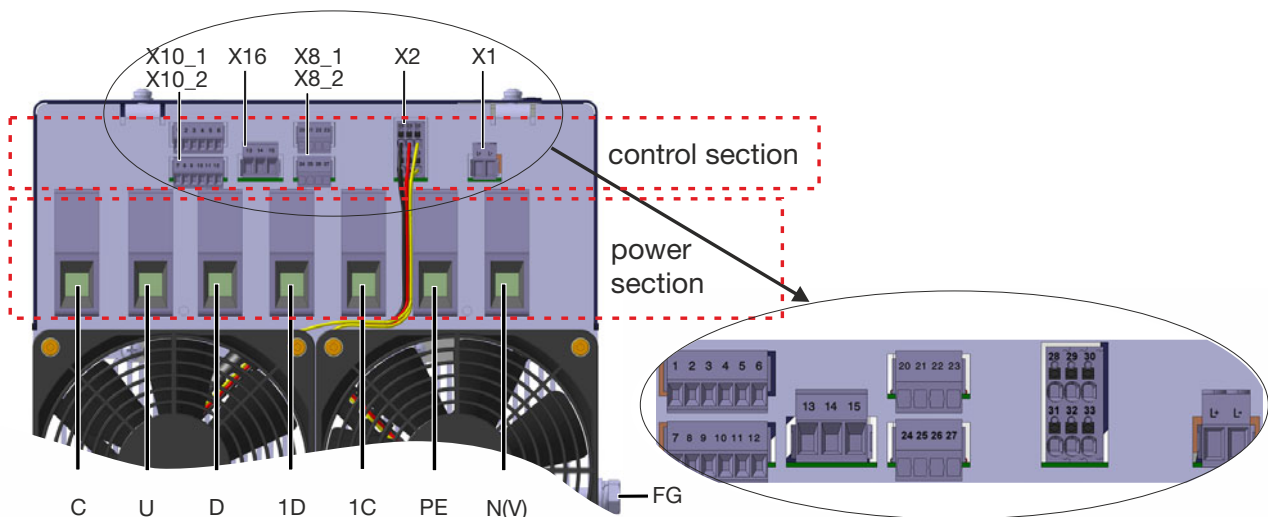

Terminal	Version	Conductor section	cross	Maximum tightening torque
C to N(V)	Hex socket screws wrench size 5 mm Cable with ferrule	10 to 50 mm ²		6 to 8 Nm
FB ground terminal (Functional bonding)	Hexagon nut wrench size 13 mm	Cable lug with hole: 8.4 mm		9 Nm

3 Electrical connection

3.1.2 Type 709051/X-XX-200...

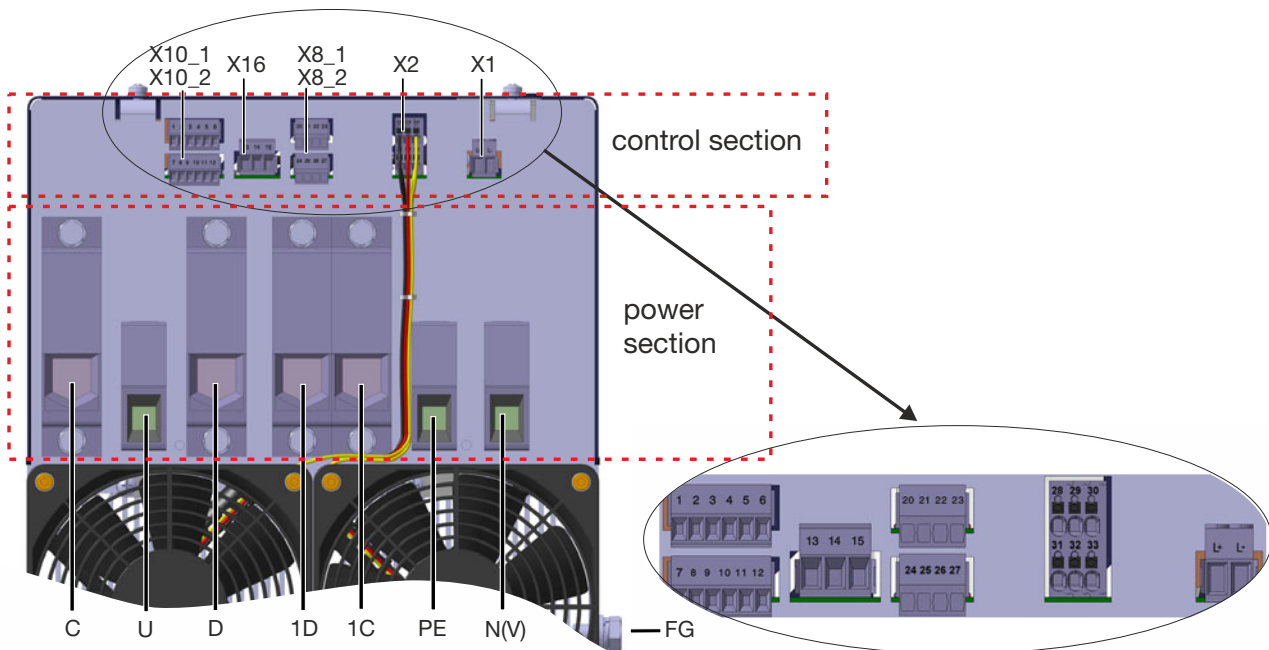

Terminal	Version	Conductor cross section	Maximum tightening torque
C, 1C, D, 1D	Hex socket screws wrench size 6 mm Cable with ferrule	30 to 95 mm ²	15 to 20 Nm
U, PE, N(V)	Hex socket screws wrench size 5 mm Cable with ferrule	10 to 50 mm ²	6 to 8 Nm
FB ground terminal (Functional bonding)	Hexagon nut wrench size 13 mm ²	Cable lug with hole: 8.4 mm	9 Nm

3 Electrical connection

3.2 Screw terminals for control electronics

Position The screw connections for the control electronics are the same for type 709051/X-XX-070... or 709051/X-XX-100... and type 709051/X-XX-200..., and are shown in the following image.

Tools - Flat-blade screwdriver, blade width 2.5 and 3.5 mm

Type 709051/X-XX-070... or type 709051/X-XX-100...

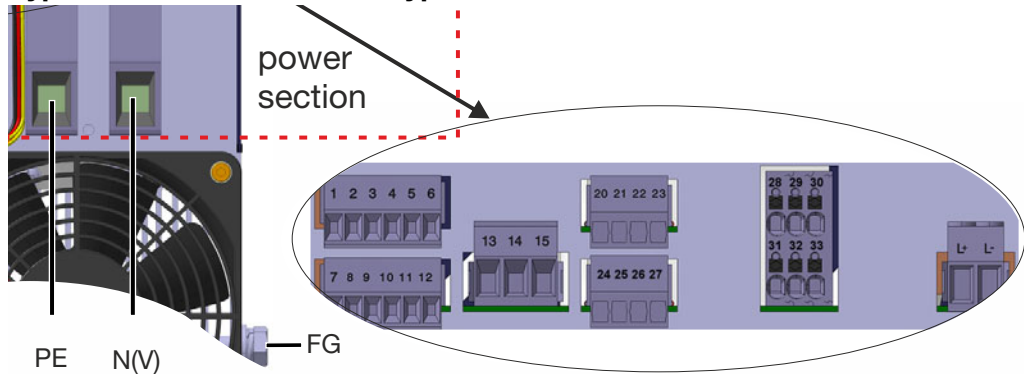

Type 709051/X-XX-200...

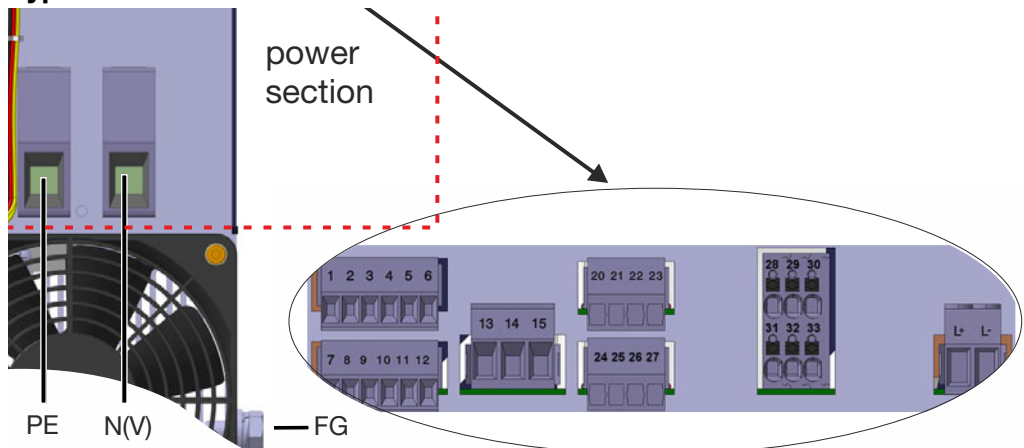

Terminal	Version	Conductor section	cross	Maximum tightening torque
X8_1, X8_2,	Slotted screws, blade width 2.5 mm	0.2 to 1.5 mm ²		0.25 Nm
X2	Push-in terminals	0.14 to 1.5 mm ²		-
X1	Slotted screws, blade width 3.5 mm	0.2 to 4 mm ²		0.5 Nm
X10_1, X10_2	Slotted screws, blade width 2.5 mm	0.2 to 1.5 mm ²		0.25 Nm
X16	Slotted screws, blade width 3.5 mm	0.2 to 4 mm ²		0.5 Nm

3 Electrical connection

3.3 Connection diagram

3.3.1 Power section

Connection for	Screw terminals (fixed)	Connection
Voltage supply, power section with upstream EMI filter	U N(V)	
Protection conductor connection	green-yellow	
Connection for function earthing conductor	FE	
Choke connection	C 1C	
Load connection	D + 1D -	

3.3.2 Control electronics



Connection for	Screw terminal X1 (pluggable)	Connection
Voltage supply DC 24 V	(L+) (L-)	

Connection for	Screw terminal X10_1 (pluggable)	Connection
Setpoint specification for current input	1 2	
Setpoint specification for voltage input (surge proof up to max. DC +32 V)	3 (GND) 4	<p>external manual-adjustment with Poti</p>
Output DC 10 V fixed voltage (max. +10 V, 2 mA)	5	
GND (ground) for setpoint specification	6 (GND)	

Connection for	Screw terminal X10_2 (pluggable)	Connection
Firing pulse inhibit	8 7 (GND PLC)	
ON logic level "1" = DC +11 to 30 V OFF logic level "0" = DC 0 to +5 V		

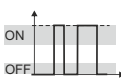
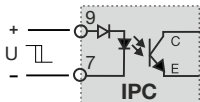
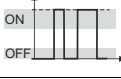
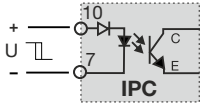
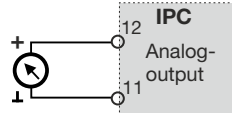
3 Electrical connection

<p>Digital input1</p> <p>ON logic level "1" = DC +11 to 30 V OFF logic level "0" = DC 0 to +5 V</p> 	<p>9 7 (GND PLC)</p>	
<p>Digital input2</p> <p>ON logic level "1" = DC +11 to 30 V OFF logic level "0" = DC 0 to +5 V</p> 	<p>10 7 (GND PLC)</p>	
<p>GND for firing pulse inhibit and digital inputs</p>	<p>7 (GND PLC)</p>	
<p>Analog output</p> <p>Various internal controller variables can be output as a standard signal of 0(4) to 20 mA, 0(2) to 10 V, and 0(1) to 5 V.</p> <p>⇒ Chapter 10.3 "Analog output"</p>	<p>12</p>	
<p>GND for analog output</p>	<p>11(GND)</p>	

Connection for	Push-in terminal X2	Connection
<p>Fan, left:</p> <p>DC 24 V, 5.4 W (already wired per default)</p>	<p>28 - 29 + 30 sensor</p>	
<p>Fan, right:</p> <p>DC 24 V, 5.4 W (already wired per default)</p>	<p>31 - 32 + 33 sensor</p>	

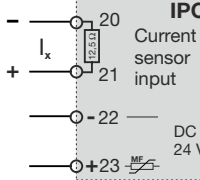
Connection for	Screw terminal X8_1 (pluggable)	Connection
<p>External current sensor 2 0(4) to 20 mA</p> <p>$P_{max.}$ at DC 24 V: ≤ 2.5 VA</p>	<p>20 - sensor signal 0(4) to 20 mA 21 + sensor signal 0(4) to 20 mA</p> <p>22 - DC 24 V supply 23 + DC 24 V supply</p>	

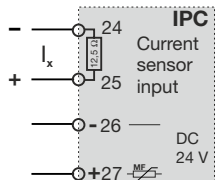
Connection for	Screw terminal X8_2 (pluggable)	Connection
<p>External current sensor 3 0(4) to 20 mA</p> <p>$P_{max.}$ at DC 24 V: ≤ 2.5 VA</p>	<p>24 - sensor signal 0(4) to 20 mA 25 + sensor signal 0(4) to 20 mA</p> <p>26 - DC 24 V supply 27 + DC 24 V supply</p>	

3 Electrical connection

3.3.3 Digital output

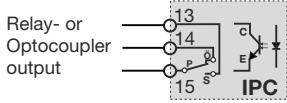
Connection for	Screw terminal X3 (pluggable)	Connection
Relay or optocoupler	13 N/O contact or collector	
	14 N/C contact	
	15 pole or emitter	

3.3.4 Interfaces (option)

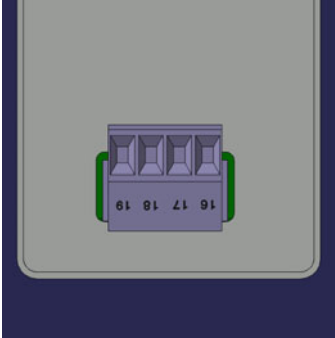
Modbus connection	RS422	RS485
 <p>Pluggable screw terminals</p>	TxD (-)	RxD/TxD B(-)
	TxD (+)	RxD/TxD A(+)
	RxD (-)	-
	RxD (+)	-
<p>The shield of the Modbus lines must be routed to ground potential (PE)!</p> 		

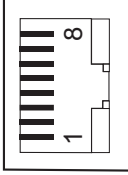
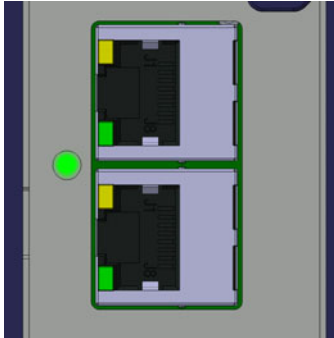
Connection	PROFINET	
	1 TX+	Transmission data +
	2 TX-	Transmission data -
	3 RX+	Received data +
	6 RX-	Received data -
<p>2 RJ-45 sockets (on the front)</p> 		

3.3.5 Suitable lines and cross-sections

In line with the operating conditions, the temperature may increase to 60 °C at the terminals. As a result, the insulation of the lines connected at the terminals may be damaged.

The affected lines must be heat-resistant up to at least 60 °C.

PE conductor

The cross section of the PE conductor must be at least as large as the cross section of the voltage supply lines in the power section.

In the event that the protection conductor is not a component of the supply line or its encasement, the selected conductor cross section may not be less than 2.5 mm² (for mechanical protection) or not less than 4 mm² (if the protection conductor is not protected mechanically).

⇒ See VDE 0100 Part 540

Control electronics

The screw terminals for the voltage supply to the control electronics are designed for a cross section between 0.2 mm² to 4 mm². The minimum conductor cross section must not be less than 0.5 mm². Fusing of the line must correspond to the selected conductor cross section.

Power consumption max. 25 W.

Power section



The minimum conductor cross section chosen must be adequate for the maximum conductor current. The electrical connection is made via screw terminals on the power controller. We recommend the use of a shielded line to reduce EMC interference emission.

⇒ Chapter 2.2 "Filtering and interference suppression" Choosing the suitable lines

The conductor cross section in the load and choke circuit must not be smaller than the conductor cross section of the supply lines in the power section!

3 Electrical connection

3.3.6 Calculation of the EMI filter current

$$I_{\text{Mains}} = I_{\text{Filter}} = \frac{\text{maximum load power consumption} + P_{\text{Loss}}}{\text{Voltage supply for power section}}$$

Example

A 3000 W heating rod is to be operated at 90 V and 33.3 A with a power controller type 709051/X-XX-070... in a 230 V mains supply. This results in the following application power loss according to the formula:

$$P_{\text{Loss}} = P_{\text{Loss max}} \times \frac{I_{\text{Appl.}}}{I_{\text{rated}}} \quad P_{\text{Loss}} = 450 \text{ W} \times \frac{33.3 \text{ A}}{70 \text{ A}}$$

$I_{\text{Appl.}}$: Load current of the application
 I_{rated} : Load current on nameplate
 P_{Loss} : Power loss (that arises on Filter, Choke and inside IPC 300)

$$P_{\text{Loss}} = 214 \text{ W}$$

$P_{\text{Loss max}}$ is taken from the table on power loss in Chapter 2.3 "Environmental influences" and amounts to (for our application with connection to 230 V): 450 W.

$$I_{\text{Mains}} = \frac{3000 \text{ W (heating load)} + 214 \text{ W}}{230 \text{ V (voltage supply to the power section)}}$$

$$I_{\text{Mains}} = 14 \text{ A}$$

With a mains current of 14 A, an EMI filter with a nominal current of 16 A is used.

3 Electrical connection

3.3.7 Galvanic isolation

The control electronics, including the inputs and outputs, as well as all control elements, can be connected to SELV circuits.

The digital output can be connected to SELV or mains potential, without prejudicing the electrical isolation arrangements of the other inputs and outputs.



There is **no** galvanic isolation between the voltage supply of the power section and the load.

Ensure that the metal case of the furnace or combustion chamber is properly earthed.

⇒ Chapter 2.2.1 "EMC-compliant design" EMC-compliant design.

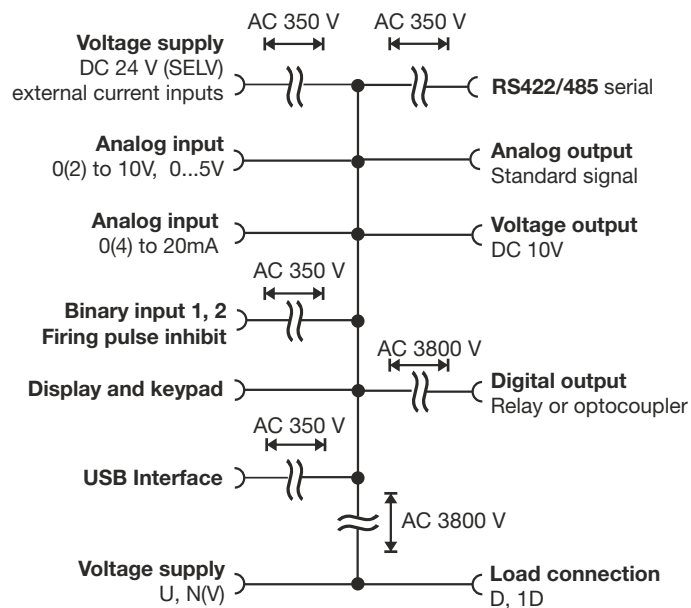

3 Electrical connection

3.3.8 Use of residual current protection devices

The device is equipped with an internal power rectifier. A short to the housing can result in a residual DC current that blocks the tripping of the conventional residual current protection device. For this reason, any RCD used must be an "all-current sensitive" version of **Type B**.

When defining the trip current for the RCD, the leakage currents of the EMI filter, caused by the Y capacitors (<3 mA), as well as the capacitive currents from the line shielding have to be taken into account.



See also EN 50178 (VDE 0160):

Protection of electrical equipment through residual current protection devices.

3.4 Switch-on sequence

First of all switch on the voltage supplies for the control electronics (DC 24 V). Only switch on the voltage supply for the power section (AC 115 V, 230 V, or 400 V) when the control electronics are already supplied.

Switch-on sequence when using bus systems

When using a bus system, the control electronics of the IPC 300 must be permanently supplied with DC 24 V, in order to maintain the field bus communication.

S1 is used to disconnect the load.

If the voltage supply of the power section is re-activated via **S1**, the IPC 300 performs a soft start (soft start of the load to the desired setpoint value).

3 Electrical connection

3.4.1 Single-phase operation: phase / N

Phase / N The diagram shows the wiring for single-phase operation **Phase / N** for Type 709051/X....

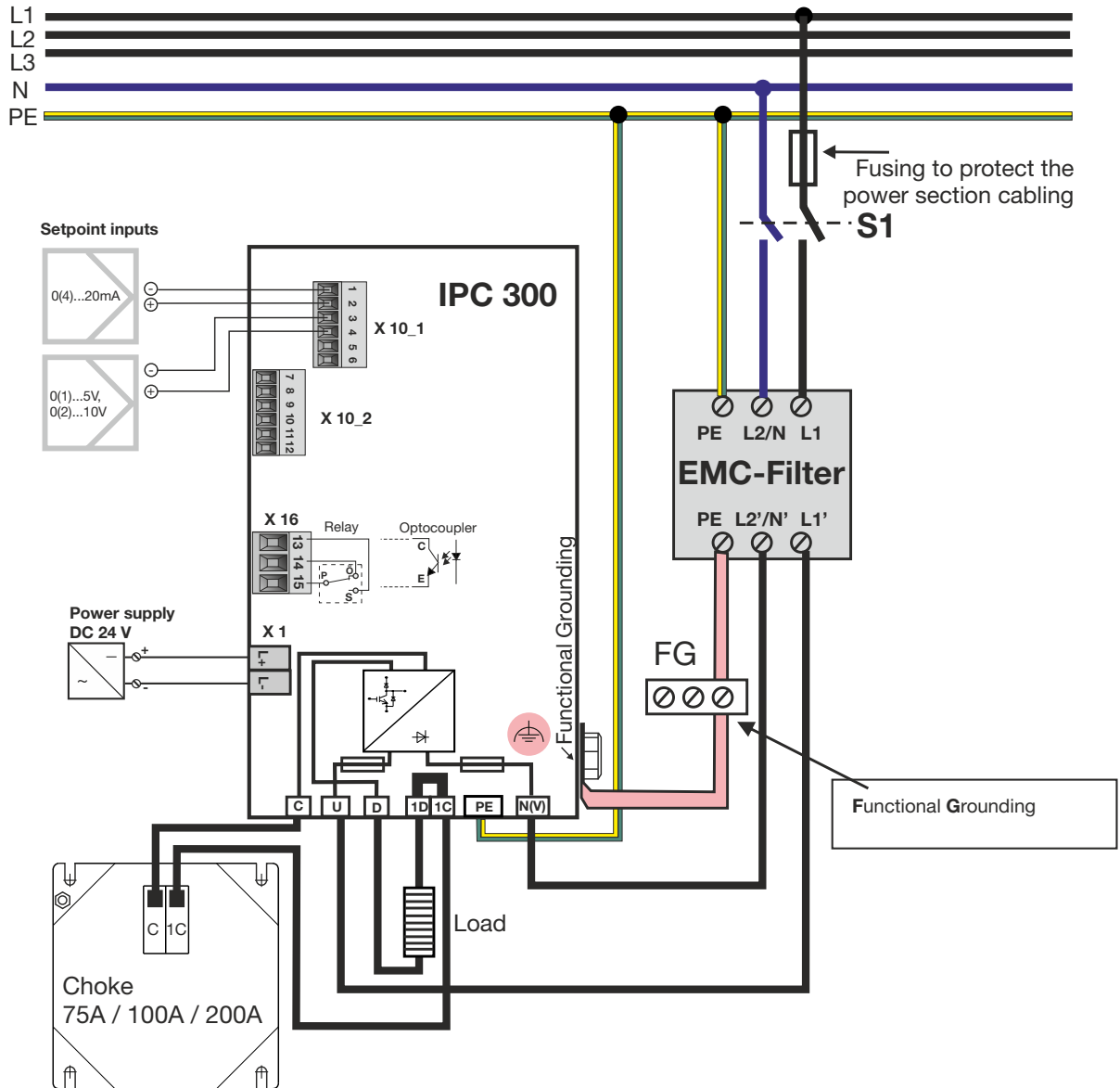

3 Electrical connection

3.4.2 Single-phase operation Phase / Phase

Phase / Phase The diagram shows the wiring for single-phase operation **Phase / Phase** for Type 709051/X....

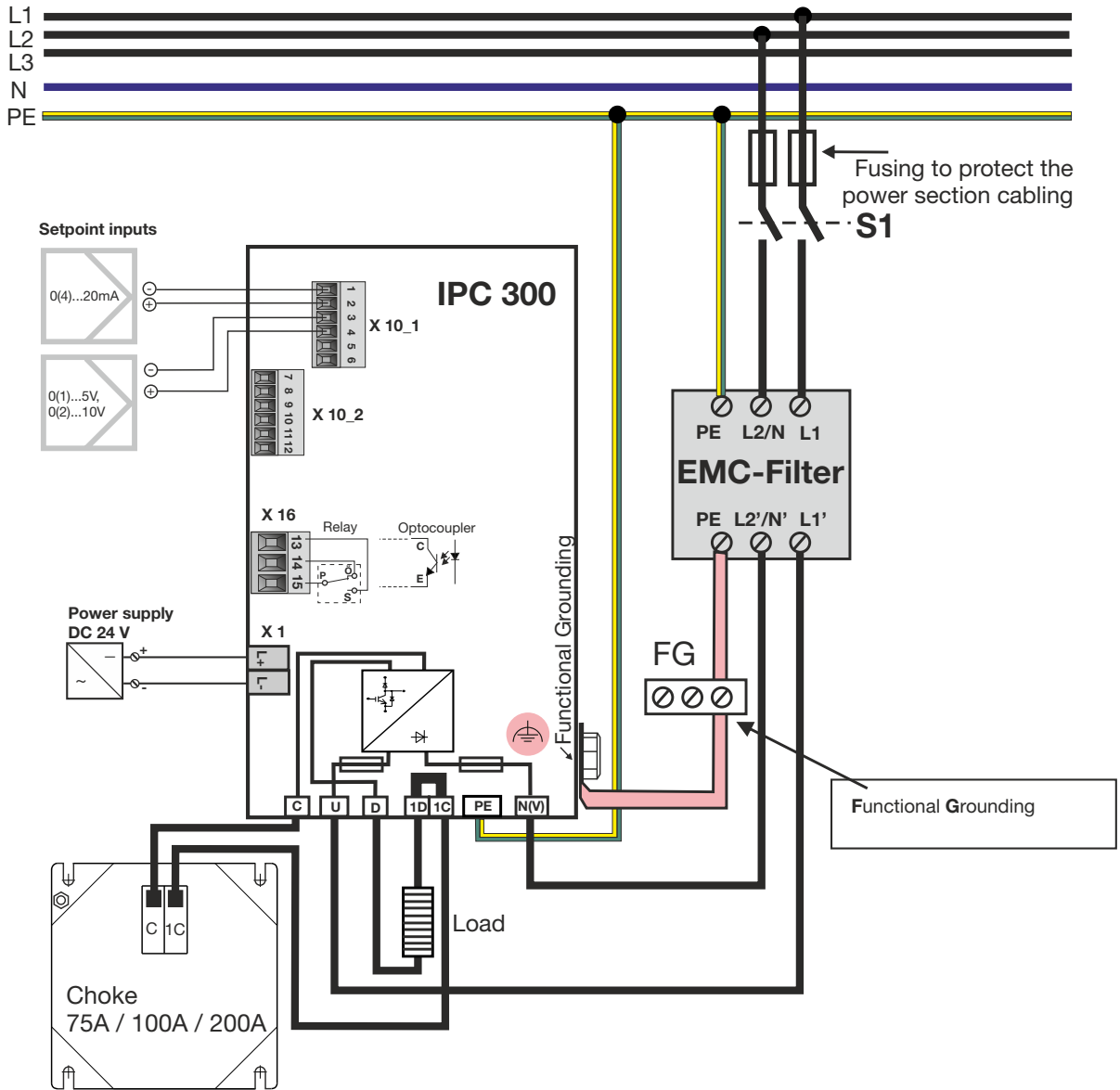

3 Electrical connection

3.4.3 Replacing the two semiconductor fuses



Caution!

The device has two voltage supplies (control electronics and power section). Disconnect both electrical circuits (all poles) prior to starting work on the device.

Allow 1 minute to elapse after disconnecting, prior to starting work on the device, since potentially fatal voltages could be present in the device interior and at the connection terminals.



Caution! Risk of burns!

The device's heat sink can heat up during operation.

The current device temperature is shown on the display.

⇒ Operating overview (on the first cover page)

- * Disconnect the device (all poles) from the voltage supply
- * Wait one minute to allow hazardous voltages to discharge.
- * Check that no voltage is present on the screw terminals of the device.

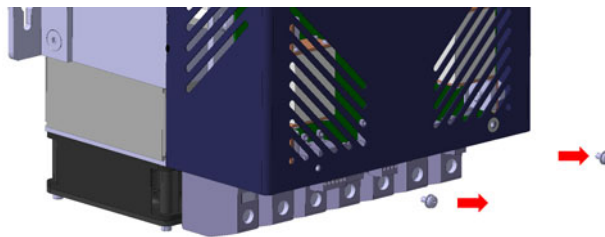

- * Undo two screws.

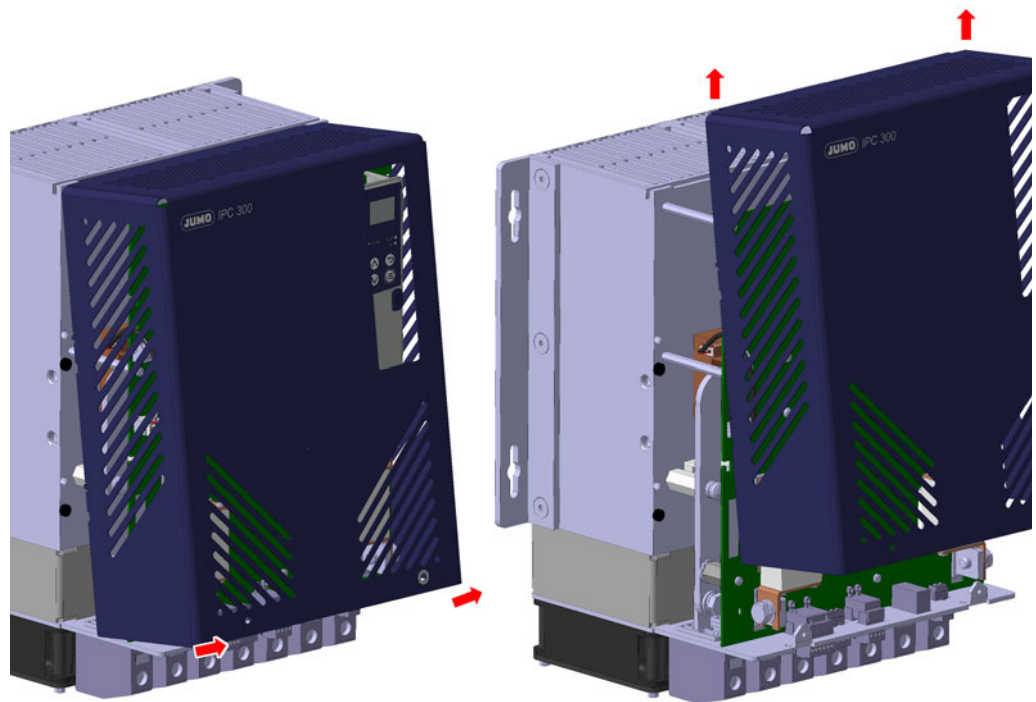

- * Tilt metal case forward and unhook from above.

3 Electrical connection

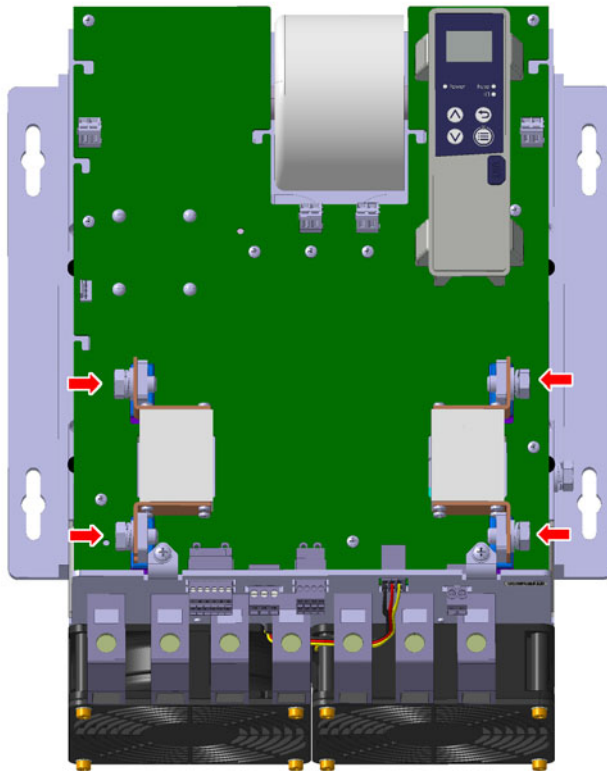

- * Undo the two screws each for the left and right semiconductor fuse and take the fuse out of its holder.
 - * Replace blown fuses with new ones and retighten the screws at a tightening torque of 9 Nm.
 - * Remedy the cause that led to the semiconductor fuse tripping (e.g. ground fault in the power section).
 - * Only use original JUMO parts, part no.: 00434229
- ⇒ Chapter 1.5 "Accessories"

4.1 Display after switching on the device

Hourglass and national language selection

As soon as the voltage supply is switched on, the Power LED first lights up permanently in green and an hourglass briefly appears on the display. The power controller then shows a range of language options on the display.

Select the national language and confirm your selection with .

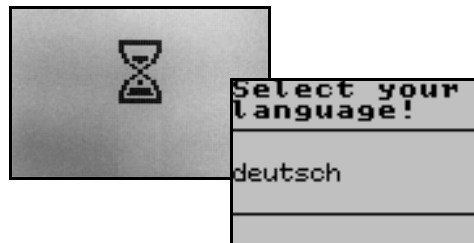

Language wizard

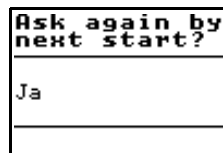

This option enables you to select whether the language wizard should be reactivated the next time the device is started.

Select "Yes" or "No", press .

Measured values then appear on the device.

⇒ Chapter 4.1.2 "Appearance of measured values".

Error messages

Info line or error

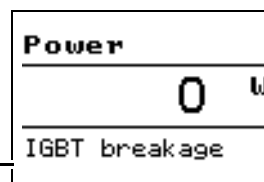

The following chapter explains the error messages that may appear in the info line at the bottom of the screen:

Chapter 8 "Error messages and alarms"

4 Operation

4.1.1 Display and control elements

Legend	Comment	Figure
1	The Power LED (green) lights up permanently when the voltage supply is connected. Chapter 9 "What to do, if ..."	
2	Display (96 x 64 pixels) with white background lighting. The information line at the bottom of the display shows the current settings and error messages.	
3	The fuse LED (red) lights up if the semiconductor fuse is defective	
4	LED K1 (yellow) collective fault signal active	
5	Keys: <ul style="list-style-type: none"> Increase value / previous parameter Decrease value / next parameter Cancel / one level back OK / one level forward 	
6	USB setup interface Hint: The connections for PROFINET as well as the meaning of the associated LEDs are explained in the "70905107T92Z001K000 Interface Description PROFINET".	

and can be used to view the current measured values such as currents, actual voltage values, setpoint value, load resistance, device temperature, and power.

This information is also displayed in the diagnosis window for the setup program.

⇒ Chapter 7 "Setup program"

4.1.2 Appearance of measured values

Measured value overview At this level, the designation of the measured value is displayed in the top line, and the numerical value together with the unit is displayed in the middle.

	Designation	Measured value	Info line or error
	Load voltage	222.6 V	$\frac{1}{2} I_x$ \square 000 %
	Load resistance	38.78 Ω	Load error
	Unit temperature	42 °C	$\frac{1}{2} I_x$ \square

The info line shows the selected input (with terminal designation), the active subordinate control loop, and the operating mode.

It is also used to display temporary states (e.g. error messages).

⇒ Chapter 8 "Error messages and alarms"

Meaning of the symbols in the info line

Input signal		Subordinate control loop		Operating mode load output	
	Voltage		U^2		Firing pulse inhibit
	Current		I^2		Soft start
	Interface		U		Current output level
			I		
			P		

4.1.3 Meaning of the displayed measured values

Measured value	Meaning	Unit
Load voltage	Effective value of the measured load voltage (Measured between the D and 1D terminals)	V
Load current	Effective value of the measured load current	A
Power	Measured effective power Note: Four-digit display in watts; values above 9999 W are shown in kW.	W or kW
Load resistance	Calculated resistance value of the load	Ω
Intermediate circuit volt.	Effective value of the measured DC intermediate circuit voltage.	V
External current input 1 to 3	Depending on the configuration	
Digital input 1, 2	Display of logic level	0 or 1
Inhibit input	Display of logic level	0 or 1
Device temperature	Currently measured temperature inside the power controller	$^{\circ}\text{C}$ or $^{\circ}\text{F}$
Voltage input	Measured value for the power controller's voltage input (Measured between terminals 3 and 4 on X2_1)	V
Current input	Measured value for the power controller's current input (Measured between terminals 1 and 2 on X2_1)	mA
Input setpoint value	Externally specified setpoint value for the subordinate control loop	%
Effective setpoint value	The effective setpoint value may deviate from the input setpoint value due to internal functions, such as the soft start or base load.	%
Output level, controller	Percentage controller output level of the subordinate control loop	%
Output level, PWM	Percentage controller output level of the PWM (pulse width modulation)	%

4 Operation

Actual value	Measured value as a percentage of the active control variable U^2 , U , I^2 , I , or P	%
--------------	--	---

4.1.4 Appearance of error messages and special statuses

Cyclical appearance

The symbols for input, subordinate control loop, and operating mode are displayed alternately in the info line together with error messages or information about special statuses. All messages are shown at least once, even if they only occur briefly.

⇒ Chapter 8 "Error messages and alarms"

Examples

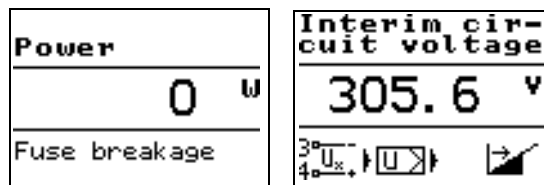

4.2 User level



All parameters for the maximum device extension level are listed in the following tables. Depending on the order details (see nameplate or device information) or the current configuration, parameters that are not required are hidden.

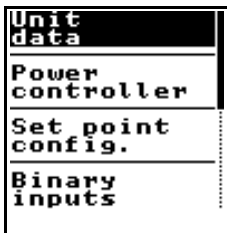



Here you will find the parameters that can be modified **during ongoing operation**.

They can be accessed without a password per default, but can also be protected with a 4-digit code if necessary.

⇒ Chapter 5.1.11 "Change codes"

During ongoing operation, the power controller can be adapted to the system and optimized.

- * In the overview of measured values, press the  key
- * Select the operating level and press  again

Editing a parameter



The changes are effective **immediately**.

Once the correct setting (e.g. for display contrast) has been found, the parameter can be stored by pressing .

If you do not wish to apply the value, the entry can be canceled by selecting

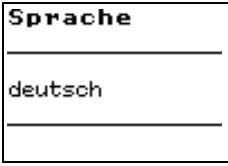
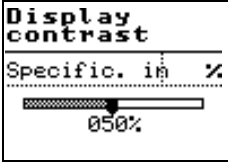

4.2.1 Device data

	Value range	Description
	deutsch english francais Setup	German (deutsch), English, and French (francais) are permanently stored in the device The national language Spanish is hidden behind "Setup", and can be overwritten by another language with the aid of the set-up program.
	25 to 50 to 75 %	Bright/dark contrast setting
	000 to 100 min	000 minutes are set per default, which means the display is not switched off.

■ / **bold** = default setting

4.2.2 Power controller

Here you can enter how high the **maximum measurand** may be. Depending on which is reached first, it is limited to the set value.

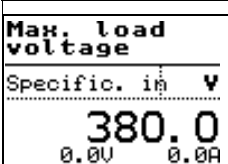
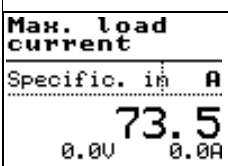
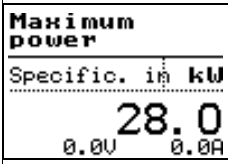
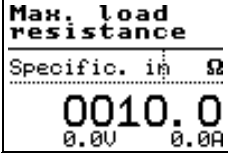
	Value range	Description
	0 to 210 V 0 to 380 V	For voltage supply network AC 230 V For voltage supply network AC 400 V
	5 to 73.5 A 5 to 105 A, 5 to 210 A	Is different depending on the power controller type ⇒ Chapter 1.3 "Order details"
	0.1 to 10 kW 0.1 to 21 kW 0.1 to 38 kW	115 V 230 V 400 V Different depending on voltage supply network
	0.1 to 9999.9 Ω	If the load resistance exceeds this value, the power output is limited.

■ / **bold** = default setting

4 Operation

4.2.3 Setpoint value configuration

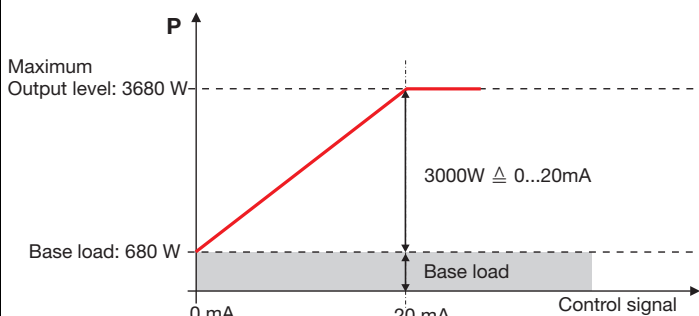
	Value range	Description
Value if fault Specif. In Ψ 001.40 0.0 V	000.00	If "Value, adjustable" is configured as the error value, this value is used in the event of a malfunction as the setpoint value at the set analog input.
Basic load Specif. In Ψ 000.00 30.1 V Current load voltage	0 to $U_{Max.}$ of the load voltage ($U_{Max.}$ = voltage supply to the power section -20 V) 0 to $P_{Max.}$ of the power ($P_{Max.}$ = $U_{Max.} \times I_{Nom.}$) 0 to $I_{Nom.}$ of the max. load current 0 to 100 % of the output level	Note: The base load setting depends on the subordinate control loop: - For voltage: 0 to 100 % $U_{Max.}$ (e.g. 0 V) - For current: 0 to 100 % $I_{Nom.}$ (e.g. 0 A) - For power: 0 to 100 % $P_{Max.}$ (e.g. 0 W) - None: 0 to 100 % of output level (e.g. 0 %) Example: 

■ / **bold** = default setting



4.2.4 Monitoring

The value to be monitored can be adjusted.

⇒ Chapter 5.1.5 "Ext. current sensor 2 and 3"

The load voltage was used in this example.

	Value range	Description
Limit value Min alarm Specif. In Ψ 0020.0 17.1 V Current measured value	0 to 9999.9	Absolute minimum limit values for load voltage, load current, power in W and kW, load resistance, DC intermediate circuit voltage, or device temperature can be monitored. ⇒ Chapter 5.1.5 "Ext. current sensor 2 and 3" Example: If the voltage falls below 20 V, an alarm is issued.
Limit value Max alarm Specif. In Ψ 0100.0 22.6 V Current measured value	0 to 9999.9	Absolute max. limit values for load voltage, load current, power in W and kW, load resistance, DC intermediate circuit voltage, or device temperature can be monitored. ⇒ Chapter 5.1.5 "Ext. current sensor 2 and 3" Example: If the voltage exceeds 100 V, an alarm is issued.

<p>Limit value Hysteresis</p> <p>Specif. In V</p> <p>0001.0 12.6 V</p>	<p>0 to 1 to 9999.9</p>	<p>The switching differential at the minimum or maximum limit value</p>
<p>Limit value Load monit.</p> <p>Specif. In %</p> <p>10.0 0.5 %</p> <p></p> <p>Current deviation from Teach-In. I.e. at > 0 % the load has become more high-resistance; at < 0 % the load is more low-resistance</p>	<p>0 to 10 to 100%</p>	<p>Partial load failure or partial load short circuit:</p> <p>The monitoring value for the percentage change to the load is set (undercurrent or overcurrent).</p> <p>By displaying the current deviation from the Teach-In value, it is possible to check whether, for example, an output-level-dependent resistance change is present.</p>
<p>Load monit. Teach-In</p> <p>Apply now</p>		<p>By pressing the  key, the current load state is applied as the OK state for load monitoring. A change in the load (load fault) will be evaluated by the device on the basis of this state.</p>

■ / **bold** = default setting

4.2.5 Binary inputs

First of all, a setpoint changeover via digital inputs must be configured.

⇒ Chapter 5.1.7 "Binary inputs"

A setpoint value specified via the analog input, as set in Chapter 5.1.3, is changed over to the value entered here (50 V), for example via Digital input 1.

	Value range	Description
<p>Setpoint at changeover</p> <p>Specific. in V</p> <p>00050.0 2.0 V</p>	<p>0 to 9999.9</p>	<p>Here the setpoint value is entered which is to become effective for the changeover via a digital input.</p>

■ / **bold** = default setting

4 Operation

5.1 Configuration level

The configuration level contains parameters for configuring the power controller.

If the parameters at this level are modified during operation, the power controller is locked (Inhibit) as a result. It does not provide any power in this state.

When exiting the configuration level with the  key, the power controller continues operation with the modified parameters.

This level can be locked with a password.

However, no password is set per default.

⇒ Chapter 5.1.11 "Change codes"



All parameters are listed in the following tables. Depending on the configuration, any parameters that are not required are hidden.

The configuration level can be accessed from the overview of measured values by pressing the following keys:

* In the overview of measured values, press the  key

* Select the configuration level and press 

The parameters are combined in the following groups, which are explained in detail as sub-chapters in the tables on the following pages.

Scroll bar



The entry highlighted in black is selected and contains further parameters.

If there are more than three entries in one level, a scroll bar that shows the current position in the menu appears.

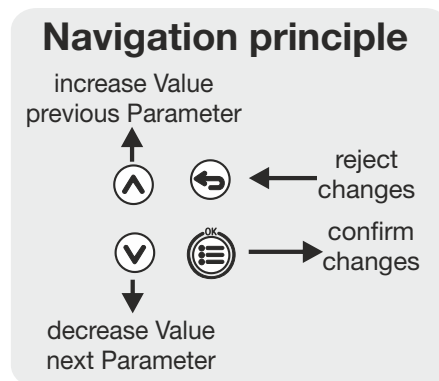
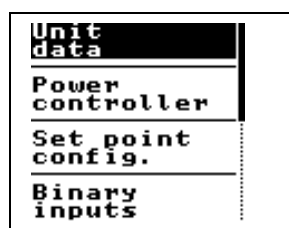
Navigation



Numerical entry or selection

Once you have reached the required parameter, the  and  keys can be used to enter a numerical value or a setting.

5 Configuration

Soft start duration Specif. In s 00001	Current Measur. rang. 0..20 mA
---	--

* Save the setting using .

If you do not wish to apply the value, the entry can be canceled by selecting .

5.1.1 Unit data





Basic settings for mains frequency, display, and temperature unit.

	Value / settings	Description
Mains frequency	50 Hz , 60 Hz	Mains frequency setting
	Yes	A query appears when the device is started, asking which national language is to be used to display the subsequent operation.
	No	No query appears
Language wizard active	deutsch	
	english	
	français	
	Setup	Spanish is added to Setup per default. Spanish can be replaced with other national languages if needs be.
Temperature unit	°C	Defines the unit for the displayed temperatures, such as the device temperature.
	°F	
Display contrast	25 to 50 to 75 %	Bright/dark contrast setting
Switch-off display lighting	000 to 100 min	The background lighting for the display switches off once the selected number of minutes has passed. Power LED (green) flashes. 0000 means: lighting is always switched on
Apply default settings	Apply now	The default settings are restored if the OK key is pressed.

■ / **bold** = default setting

5.1.2 Power controller

Settings for the switching behavior of the power controller in the system

	Value / settings	Description
Subordinate control loop	U² , U, I ² , I, P	Subordinate control loops are used to eliminate or compensate for external disturbances, such as mains voltage fluctuations and changes in load resistance, that would have a negative effect on the control process.
		<p>The U setting is used when the load voltage should be linear to the setpoint specification.</p> <p>The I setting is used when the load current should be linear to the setpoint specification.</p> <p>The following subordinate control loops have proven advantageous for heating elements that do not have linear temperature behavior or that are subject to aging:</p> <p>U² is used for:</p> <ul style="list-style-type: none"> - Positive temperature coefficient, molybdenum disilicide - If $R \approx$ is constant - Brightness controls. <p>I² is used for:</p> <ul style="list-style-type: none"> - Negative temperature coefficient (TC) <p>P is used for:</p> <ul style="list-style-type: none"> - Temperature-dependent temperature coefficient - General applications - SiC load with automatic aging compensation
		
		
		
		
Soft start	No	This setting determines the starting behavior of the power controller after power ON and is deactivated per default.
	Yes	"Yes" means that a soft start is performed after power ON.
Soft start duration	0 to 10 to 65535 s	Specifies the duration of the soft start.
Voltage supply U-N(V)	115, 230, or 400 V	Specifies which voltage supply is used to operate the power section of the power controller.
Customer-spec. voltage	400 to 30 V	Here any value can be entered for another voltage supply network.
Max. load voltage	0 to 95 V	For voltage supply network AC 115 V
	0 to 210 V	For voltage supply network AC 230 V
	0 to 380 V	For voltage supply network AC 400 V
	Note:	For U- or U ² control the value entered here is the load voltage output by the controller at 100% setpoint value. For all other control types, the power controller limits the load voltage to the value entered here.

■ / **bold** = default setting

5 Configuration

	Value / settings	Description
Max. load current	5 to 73.5 A	Is different depending on the power controller type ⇒ Chapter 1.3 "Order details" For I- or I ² control, the value entered here is the current strength output by the power controller at 100% setpoint value. For all other control types, the power controller limits the load current to the value entered here.
	5 to 105 A,	
	5 to 210 A	
Max. power	0.1 to 38 kW	400 V Different depending on voltage supply network
	Note:	The configurable range applies for a load current of 200 A. Depending on the voltage supply and the power controller type, this max. configurable value is reduced. For P control the value entered here is the power output by the controller at 100% setpoint value. For all other control types, the power controller limits the power output to the value entered here.
Resistance limitation	No	No limitation through load resistance
	Yes	The load resistance is monitored to ensure the selected resistance limit value is not exceeded if the load current is > 5% of the maximum load current. Chapter 6.5 "Resistance limitation (r-control)"
Max. load resistance	0.1 to 9999.9 Ω	If the load resistance exceeds this value, the power output is limited.

■ / **bold** = default setting

5.1.3 Analog inputs

The power controller has a voltage input and a current input. These inputs (setpoint specification) specify the power to be provided by the power controller at the load output. In most cases, this signal is sent as a standard signal from an electronic controller or a PLC and is adjusted with these settings.

	Value / settings	Description
Current measuring range	0 to 20 mA	This setting specifies which current standard signal is connected. ⇒ Chapter 3.4 "Switch-on sequence"
	4 to 20 mA	
	Customer-specific ¹	
Current measuring range, start	0 to 20 mA	Note: This parameter only appears if "Customer specific" is set for the current measuring range (see above)!
Current measuring range, end	0 to 20 mA	Note: This parameter only appears if "Customer specific" is set for the current measuring range (see above)!
Voltage measuring range	0 to 10 V	This setting specifies which voltage standard signal is connected. ⇒ Chapter 3.4 "Switch-on sequence"
	2 to 10 V	
	0 to 5 V	
	1 to 5 V	
	Customer-specific ¹	

■ / **bold** = default setting

	Value / settings	Description
Voltage measuring range, start	0 to 10 V	Note: This parameter only appears if "Customer specific" is set for the voltage measuring range (see above)!
Voltage measuring range, end	0 to 10 V	Note: This parameter only appears if "Customer specific" is set for the voltage measuring range (see above)!



■ / **bold** = default setting

1. Inverting analog inputs:

If, for example, the current measuring range start is set to 20 mA and the current measuring range end is set to 0 mA, the power controller is switched off at 20 mA and switched on at 0 mA.

5.1.4 Setpoint configuration

This setting determines which input specifies the setpoint value, how high the base load is, and which replacement value should be applied in the event of malfunction.

	Value / settings	Description
Setpoint specification	Current input 	This setting specifies where the setpoint value for the power output comes from.
	Voltage input 	
	Via interface 	
Input in the event of an error		Current, voltage, and interface input are monitored for errors (wire breaks or bus errors). This setting specifies which replacement value the power controller should use if the setpoint specification is incorrect.
	Last value	
	Voltage input	If, for example, an error (e.g. wire break) now occurs at the current input that is selected for the default setpoint specification, the power controller uses the value at the voltage input.
	Current input	
	Value, adjustable	This means that the " Value in the event of an error " is used.
Value in the event of an error	000.0	If "Value, adjustable" is configured as the error value, this value is used in the event of a malfunction.

5 Configuration

Base load

<p>0 to U_{Nom} of the load voltage,</p> <p>0 to I_{Nom} of the max. load current</p> <p>0 to P_{Nom} of the power</p>	<p>Note: The base load setting depends on the subordinate control loop:</p> <ul style="list-style-type: none"> - For voltage: 0 to 100 % of the max. load voltage (e.g. 0 V) - For current: 0 to 100 % of the max. load current (e.g. 0 A) - For power: 0 to 100 % of the power (e.g. 0 W) <p>Example:</p>
--	---

■ / **bold** = default setting

5.1.5 Ext. current sensor 2 and 3

This setting configures which measurand is to be recorded.

Value / settings	Description
None	Switched off
Error current	By connecting an error current sensor, which outputs a standard signal of 0 to 20 mA, for example, the system can be monitored as regards an error current limit value. The following values must be entered: - Sensor output signal: 0 to 20 mA, 4 to 20 mA, customer-specific - Sensor input measuring range: 0 to 500 mA, customer-specific - Limit value error current When a limit value is exceeded, there is an error message. ⇒ Chapter 6.8 "External current sensors"
Load current	By connecting a load current sensor, which outputs a standard signal of 0 to 20 mA, for example, the system can be monitored as regards a load current limit value. ⇒ Chapter 6.8 "External current sensors"
Mains current	By connecting a mains current sensor, which outputs a standard signal of 0 to 20 mA, for example, the system can be monitored as regards a mains current limit value. ⇒ Chapter 6.8 "External current sensors"

■ / **bold** = default setting

5.1.6 Monitoring

This allows an internal measurand to be monitored for compliance with limit values.

Depending on the switching behavior, an overrange or underrange is output at the digital output (option: relay or optocoupler).

Value / settings	Description	
Limit value monitoring function	<p>Limit value monitoring</p>	
Switched off		No monitoring
Load voltage		These measurands can be monitored.
Load current		
Power (in W)		
Power (in kW)		
Load resistance		
Intermediate circuit voltage		
Device temperature		
Mains current		
Min. alarm limit value	<p>0 to 9999.9</p> <p>Absolute minimum limit values for load voltage, load current, power, load resistance, DC intermediate circuit voltage, device temperature, or mains current can be monitored. If the measurand falls below this value, an error message appears at the bottom of the display and the yellow K1 LED lights up. Depending on the set control direction, the digital output switches as shown in the diagram. The unit of the limit value corresponds to the measurand to be monitored.</p>	
Max. alarm limit value	<p>0 to 9999.9</p> <p>Absolute max limit values for load voltage, load current, power, load resistance, DC intermediate circuit voltage, device temperature, or mains current can be monitored. If the measurand exceeds this value, an error message appears at the bottom of the display and the yellow K1 LED lights up. Depending on the set control direction, the digital output switches as shown in the diagram. The unit of the limit value corresponds to the measurand to be monitored.</p>	
Limit value hysteresis	<p>0 to 1 to 9999.9</p> <p>Switching differential at the upper and lower limit of the monitoring range</p>	

5 Configuration

Load monitoring	None	The load is not monitored.
	Undercurrent	Note:
	Overcurrent	⇒ Chapter 6.2 "Detection of load faults"
Limit value load monitoring		Note: This setting is only available if load monitoring has been set to undercurrent or overcurrent.
	0 to 10 to 100 %	Partial load failure or partial load short circuit: This setting specifies the percentage by which the load resistance must have decreased or increased for a load fault to be triggered.
Load type load monitoring	Standard	Default setting (suitable for most load types)
	Infrared radiator (short-wave)	Especially suitable for short-wave infrared radiators
Teach-In type load monitoring	Manual	Teach-In can be performed in manual mode or in the operating level . ⇒ Chapter 6.3.2 "Configuring Teach-In (prerequisite for Teach-In in manual mode)" ⇒ Chapter 4.2.5 "Binary inputs"
	Automatically once	The Teach-In value is automatically determined once after each power ON. ⇒ Chapter 6.2.1 "Teach-In"
	Automatic (cyclically)	Teach-In is performed cyclically at a time interval of 1 minute. This setting is particularly suitable for SiC heating elements.
SiC monitoring	No	No monitoring
	Yes	This setting for the monitoring of SiC heating elements uses a binary signal to indicate when the power required by the setpoint specification can no longer be reached with the load present, due to aging of the heating elements. This error is shown in the info line when the actual value of the subordinate control loop is smaller than the required setpoint value for an uninterrupted period of 7 minutes. ⇒ Chapter 8 "Error messages and alarms"

■ / **bold** = default setting

5.1.7 Binary inputs

There are two digital inputs and an additional digital input for firing pulse inhibit available to which a PLC level can be applied.

The following functions can be triggered with digital input 1 and 2:

* Switch to the configuration level → Binary inputs using the  key

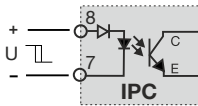
	Value / settings	Description
External change-over of setpoint specification	Switched off	No external changeover of setpoint specification
	Digital input1	Changeover is controlled by digital input1
	Digital input2	Changeover is controlled by digital input2
	Ext. digital input1	Changeover is controlled via an interface
	Ext. digital input2	Changeover is controlled via an interface
Setpoint specification for changeover	Voltage input	Selects the source that is used to specify the setpoint value when external changeover of the setpoint specification is activated. Note: The only analog inputs that are available here are those that have not yet been populated by a setpoint specification, for example.
	Current input	
	Value, adjustable	
Setpoint value for changeover	0 % to 100 %	Note: This parameter is available only if " Value, adjustable " is selected for setpoint specification for changeover.
Keypad locking	Switched off	No key lock
	Digital input1	Key lock is controlled by digital input1
	Digital input2	Key lock is controlled by digital input2
	Ext. digital input1	Key lock is controlled via an interface
	Ext. digital input2	Key lock is controlled via an interface
External switch-off of display lighting	Switched off	No external switch-off, i.e. the background lighting behaves according to the configuration in Chapter 5.1.1
	Digital input1	Switch-off is controlled by digital input1
	Digital input2	Switch-off is controlled by digital input2
	Ext. digital input1	Switch-off is controlled via an interface
	Ext. digital input2	Switch-off is controlled via an interface
Inhibit input control direction		The firing pulse inhibit can be triggered in the event of "high or low switching level". ⇒ Chapter 3.3 "Connection diagram"
	"high load ON"	Per default:
	"high load OFF"	Inhibit input "high", power controller does not supply power. Inhibit input "low", power controller supplies power.
		
Control direction, digital input1	high inactive	The function for digital input 1 can be triggered for "high or low switching level".
	high active	

■ / **bold** = default setting

5 Configuration

	Value / settings	Description
Control direction, digital input2	high inactive	The function for digital input 2 can be triggered for "high or low switching level".
	high active	

■ / **bold** = default setting

5.1.8 Binary output

The digital output consists of a relay or an optocoupler, depending on the order code.

With the digital output, it is possible to choose between the output mode "**collective fault transmitter**", or "**Interf. signal**".

⇒ Chapter 8.1 "Binary signal for collective fault"

The control direction is used to select the switching behavior of the relay and determine whether, in the event of an error message, if it should switch on (error message via N/O contact) or drop out (error message via **N/C contact**). In the optocoupler, the control direction determines whether the collector-emitter loop should be conductive or **high-impedance** in the event of an error message.

* Use the  key to switch to the configuration level → Digital output

	Value / settings	Description
Output mode	Collective fault transmitter	The digital output switches if a collective fault occurs on the device. This can be configured as an "N/C contact" or as an "N/O contact" (see below). The K1 LEDs also light up in the event of a fault.
	Interf. signal	The digital output is controlled via an interface

■ / **bold** = default setting

5 Configuration

Control direction,
digital output

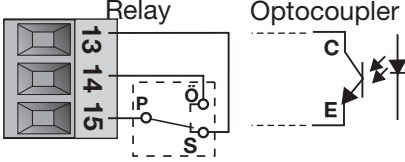
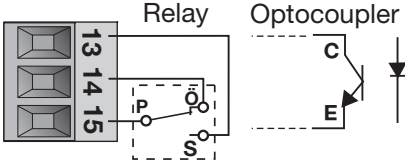
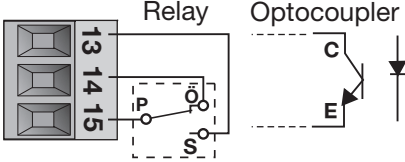
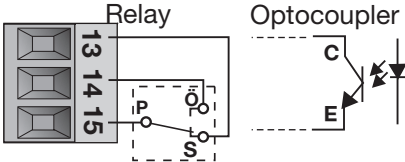
Value / settings	Description
<p>Normally open contact</p>	<p>Error message present or signal via interface is logic level 1 "High": Switching behavior: 13 and 15 pole and N/O contact closed or 13 and 15 optocoupler <u>collector-emitter loop low-impedance</u></p>  <p>No error message or signal via interface is logic level 0 "Low": Switching behavior: 14 and 15 pole and N/C contact closed or 13 and 15 optocoupler collector-emitter loop high-impedance</p> 
<p>Normally closed contact</p>	<p>Error message present or signal via interface is logic level 1 "High": Switching behavior: 14 and 15 pole and N/C contact closed or 13 and 15 optocoupler <u>collector-emitter loop high-impedance</u></p>  <p>No error message or signal via interface is logic level 0 "Low": Switching behavior: 13 and 15 pole and N/O contact closed or 13 and 15 optocoupler collector-emitter loop low-impedance</p> 

■ / **bold** = default setting

5 Configuration

5.1.9 Analog output

Different internal values can be output as a standard signal at the analog output.

	Value / settings	Description
Signal type		This setting specifies the standard signal that should be output.
	Switched off	Output does not emit signal.
	0 to 20 mA	Output emits the "Value to be output" in the form of a current signal.
	4 to 20 mA	
	0 to 10 V	Output emits the "Value to be output" in the form of a voltage signal.
	2 to 10 V	
	0 to 5 V	
	1 to 5 V	
Value to be output		This setting involves the selection of the value that should be output at the analog output.
	Load voltage	Example: The load voltage can vary between 0 and 380 V depending on the device type. As the signal range is set per default to 0 to 9999.9, the end value must be adjusted to 380.0 to make use of the full signal range. Note: Load voltage ² = load voltage squared Load current ² = load current squared
	Load voltage ²	
	Load current	
	Load current ²	
	Power (in W)	
	Power (in kW)	
	Load resistance	
	DC intermediate circuit voltage	
	Device temperature	
Setpoint value		
Signal range start value	0 to 9999.9	Lower limit for the "Value to be output"
Signal range end value	0 to 9999.9	Upper limit for the "Value to be output"

■ / **bold** = default setting

5.1.10 RS422/485

Interface parameters for RS422/485 (see interface description)

	Value / settings	Description
Baud rate	9600	
	19200	
	38400	
Data format	8-1-none	Data bits-stop bits-parity check
	8-1-odd	
	8-1-even	
	8-2-none	
Device address	0 to 1 to 255	According to Modbus specification, the address 0 is actually not permitted. In the IPC 300 it is used to switch off the signaling of a bus error. Therefore if the power controller has an RS422/485 interface, and this is not connected to an active bus, you can suppress the "bus error" error message by changing the address to 0.

Min response time **0 to 500ms**
■ / **bold** = default setting

5.1.11 Change codes

Here, it is possible to assign passwords (4-digit numeric codes) for **manual mode**, **operating level**, and **configuration level** to protect them from unauthorized access.

	Value / settings	Description
Code, manual mode	0000 to 9999	0000 means: no locking 9999 means: level is hidden
Code, operation level	0000 to 9999	0000 means: no locking 9999 means: level is hidden
Code, config. level	0000 to 9999	0000 means: no locking If the code is not equal to 0000, it is only possible to read out the configuration using the setup program if you enter the right code beforehand.

■ / **bold** = default setting

5 Configuration

6.1 Subordinate control loop

Subordinate control loops are primarily used to eliminate or compensate for external disturbances, such as fluctuations in the voltage supply and alterations in resistance that have a negative effect on the control process.

Default setting A subordinate U^2 control loop is set, but U or I or I^2 or P control loops can also be configured.

Control loop	Application
U^2	<ul style="list-style-type: none"> - Positive TC, molybdenum disilicide - $R \approx \text{constant}$ - Brightness controls
P	<ul style="list-style-type: none"> - General application, necessary for SiC load and automatic aging compensation.
I^2	<ul style="list-style-type: none"> - Negative TC

■ default setting

6.2 Detection of load faults

The load monitoring detects the percentage change in resistance of the load following Teach-In (from an input setpoint value $\geq 3\%$). It can detect and signal a load failure, partial load failure, or a partial load short circuit. **Note:** With the IPC 300, there is also the possibility to detect load failures using external current sensors.

⇒ Chapter 6.8 "External current sensors"

Undercurrent This function is used for one or more heating elements connected in parallel that are to be monitored for failure.

Overcurrent This function is used for several heating elements connected in series that are to be monitored for short circuits.

Function This function not only takes the decreasing or increasing load current into consideration, but also includes the load voltage in the monitoring process (resistance measurement).

The system's correct load ratios are saved during Teach-In.

The load changes are monitored based on this state. In the event of a break or short circuit of a heating element, the load current increases or decreases. This is detected by the load monitoring and a load fault is signaled.

Limit value A limit value must be entered as a % in the configuration or operating level for load monitoring. This limit value depends upon the number of heating elements connected in parallel or in series.

For heating elements with a high positive or negative temperature coefficient, a suitable limit value must be determined independently. The % value shown below (see arrow) can be used as an aid for this.

6 Special device functions

This value represents the current deviation from the Teach-In value.
 If the value is > 0 %, the load has become **more high resistance**;
 if the value is < 0 %, it has become **more low resistance**.
 This window can be accessed via
 Operating level \rightarrow Monitoring \rightarrow Limit value load monit.

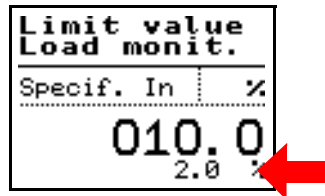

For heating elements with a temperature coefficient $TC \approx 1$, the limit value can be taken directly from the following tables:

Undercurrent

Number of heating elements	Single-phase operation
5	10 %
4	13 %
3	17 %
2	25 %
1	50 %
Example: 2 heating elements	<p>The diagram shows a single-phase supply with lines L1 and N. An IPC 300 device is connected between L1 and N. The output terminals of the IPC 300 are labeled D and 1D. Two heating elements are connected in parallel between terminals D and 1D.</p>

The specifications in % refer to **load current changes**

6 Special device functions

Overcurrent

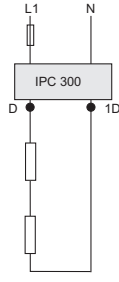
Number of heating elements	Single-phase operation
6	10 %
5	13 %
4	17 %
3	25 %
2	50 %
Example for 2 heating elements	 <p>The diagram shows a single-phase circuit. A line labeled 'L1' is connected to terminal 'D' of an 'IPC 300' device. A neutral line labeled 'N' is connected to terminal '1D' of the same device. Two heating elements, represented by rectangles, are connected in series between terminals 'D' and '1D'.</p>

The specifications in % refer to **load current changes**



As a general rule, load monitoring does not yet take place during the soft start phase (which can last for an extended period due to active current limiting) as the standard working range of the load has not yet been reached. Teach-In cannot be performed in this phase either.

6 Special device functions

6.2.1 Teach-In

Depending on the configuration of the parameter "Load monit. Teach-In", Teach-In (i.e. determination of the load measured values in the OK state) is either performed once automatically after power ON or automatically and cyclically, repeatedly every minute, or manually.



Teach-In is not possible during the soft start phase (which can last for an extended period due to active current limiting).

The determined Teach-In values are also transferred when the setup data of one power controller is transferred to another.

"Manual" teach-in

For "Manual Teach-In", the power controller must be told once after the working point has been reached that it is now to perform the Teach-In. This can be performed in the operating level or in manual mode.

⇒ Chapter 4.2.5 "Binary inputs"

⇒ Chapter 6.3.2 "Configuring Teach-In (prerequisite for Teach-In in manual mode)"

In this variant of Teach-In, the Teach-In values are then permanently saved. Teach-In does not need to be performed again when the power controller is switched off and on again.

Teach-In can be repeated whenever necessary. The old Teach-In values are then overwritten by the new ones.

The Teach-In values are only deleted if the load monitoring Teach-In parameter is explicitly configured to "Manual Teach-In" or when the default setting is applied. Teach-In is not affected when other parameters are reconfigured.

If there has not yet been a correct Teach-In process, the message "Teach-In missing" appears on the display as a reminder.

"Manual Teach-In" can only be performed on the device itself, not via the setup program.



To ensure that the load ratios are recorded precisely for later operation, only perform the Teach-In process at a load current of at least 20 % of the nominal value!

Teach-in "Automatically once"

"Automatically once" means that the Teach-In values are temporarily saved after each power ON. This setting is suitable only for heating elements with a temperature coefficient $TC \approx 1$.

When the power controller is disconnected from the mains voltage, the Teach-In values are deleted again. After another power ON, load monitoring therefore remains inactive until a new Teach-In process is performed.

To ensure that the load ratios are recorded precisely for later operation, Teach-In is only performed with at least 30 % of the output level.

Teach-in "Automatic (cyclically)"

"Automatically (cyclically)" means that the Teach-In values are temporarily saved again at intervals of one minute. This setting is particularly suitable for SiC heating elements as in this case the resistance in the load point changes

6 Special device functions

with time due to aging.

When the power controller is disconnected from the mains voltage, the Teach-In values detected last are deleted and recalculated once the mains voltage supply has returned.





6.3 Manual mode

In this case, the setpoint value can be manually preset from 0 to 100 % without the need for external wiring via the analog input.

6.3.1 Setpoint specification in manual mode

Starting

Manual mode, as set per default, can be accessed without entering a code.

- * Press the  key once (selection menu)
- * Press the  key again (manual mode)
- * Use the  or  key to increase or decrease the setpoint value

The changes become effective immediately at the load output and are indicated on the display.

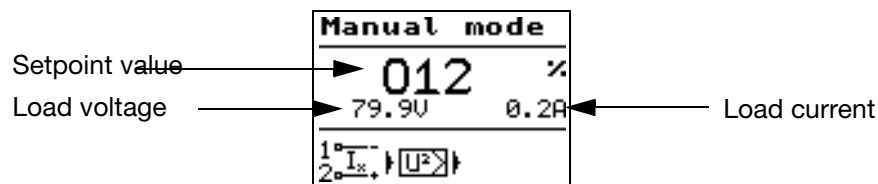



The setpoint value for manual mode is not saved in the event of a power failure!

6.3.2 Configuring Teach-In (prerequisite for Teach-In in manual mode)

The Teach-In function records the current/voltage ratio of a load in the OK state.

Configuring "manual" Teach-In

The power controller is in the "Measured value overview" level.

- * Press the  key
Config. level → Monitoring → Load monitoring → Undercurrent or overcurrent → Teach-in type load monit. → Set to "manual"
- * Press the  key
- * Press the  key twice

If Teach-In is being performed for the first time, the message "Teach-In missing" appears in the bottom line of the display.

6 Special device functions

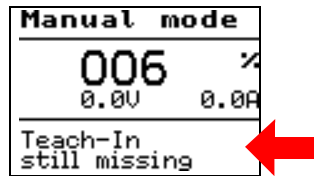



6.3.3 Performing Teach-In in manual mode

The power controller is in the "Measured value overview" level.

- * Press the  key twice to return to **manual mode**.

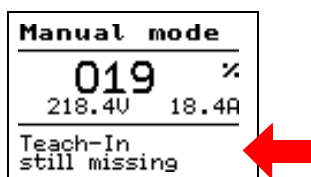
If Teach-In is being performed for the first time, the message "Teach-In missing" now appears in the bottom line of the display.



- * Press the  key and the following message appears:



- * Press the  key to apply the current load state as the OK state.



NOTE:

If the load parameters:

- Max. load voltage
- Max. load current
- Max. power

are set too far or deviate too much from the actual working point of the load, this may mean the Teach-In is not applied. The message "Teach-In missing" is then still shown on the display.

Reason

For the Teach-In process, at least 5% of the set max. load current must flow so that the correct resistance values for the Teach-In process can be calculated.

A change in the load (load fault) will be evaluated by the device on the basis of this state.

Repeating Teach-In

Teach-In can be repeated any number of times in manual mode.

- * Press the  key and the following message appears:



- * Press the  key to apply the current load state as the OK state.

6.4 Setpoint specification via potentiometer

For this, a 5 k Ω potentiometer is connected to the voltage input.

It is supplied with DC 10 V at terminal 5 of the power controller.

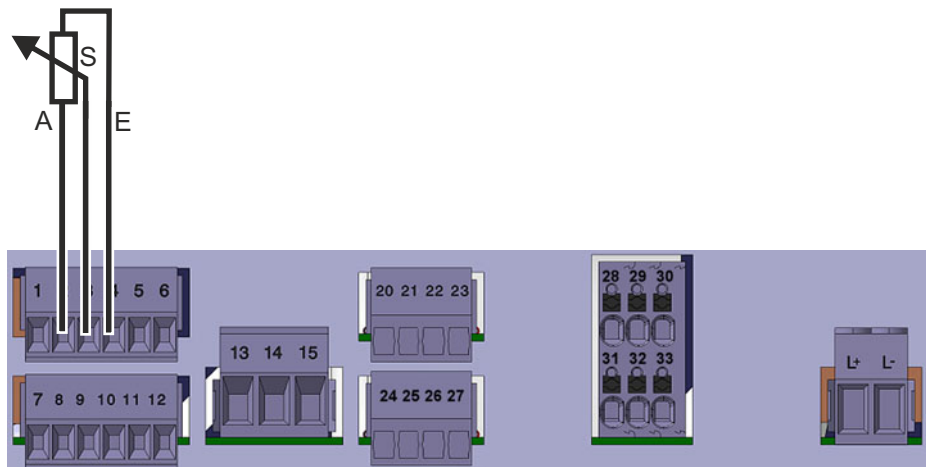

- * Configuration level \rightarrow Analog inputs \rightarrow Set voltage range 0 to 10 V
- * Configuration level \rightarrow Setpoint value config. \rightarrow Default setpoint value \rightarrow Set voltage input

Now the power controller power is preset via the external potentiometer.

6 Special device functions

6.5 Resistance limitation (r-control)



This only works for load resistances with a positive temperature coefficient.

Function

If the current resistance measurement exceeds the resistance limit value, the power output is limited via the amplitude control.

Resistance limitation is used in the operation of molybdenum disilicide heating elements to avoid overheating in the upper temperature range. By measuring the resistance of the heating element, it is possible to assign a precise heating element temperature and it is therefore protected against overheating.

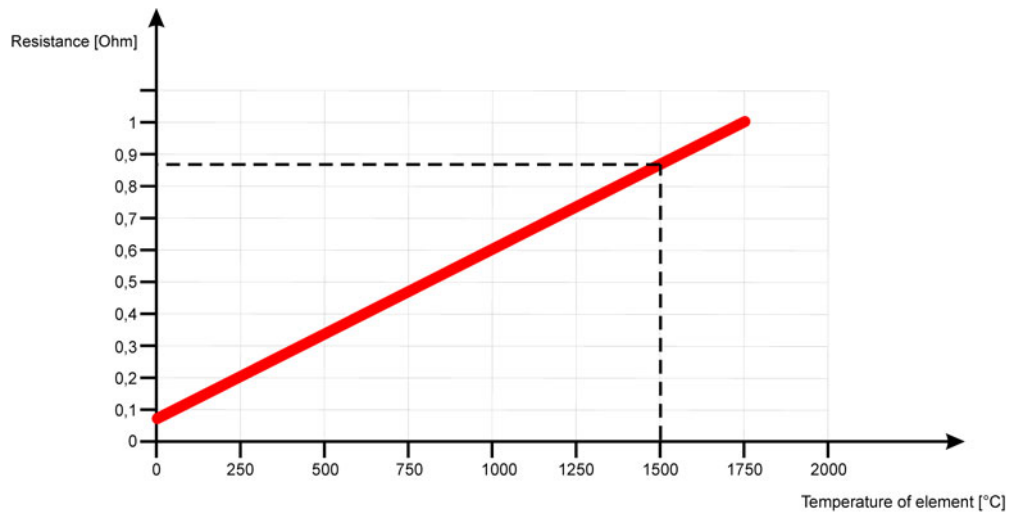

6.6 Current limiting

Function Current limiting is implemented via amplitude control. It prevents overcurrents in the load circuit and limits the load current independently of the load resistance and the setpoint value to the required current limit value.

Current limiting is unavoidable for heating elements with a high positive temperature coefficient, such as Kanthal-Super, for example. Without current limiting, the load current would accept inadmissibly high values when such heating elements are in a cold state.

Default setting Current limiting is not active.

If necessary, current limiting must be switched on in the configuration level.

⇒ Chapter 5.1.2 "Power controller"

The current limit value can be adjusted both in the configuration level or in the operating level. In the operating level, it can be adjusted during operation.

6.7 Firing pulse inhibit

The inhibit function serves to protect the IPC 300 and the connected loads.

Internal The IPC 300 is locked in the event of:

- Switch-on of voltage supply for control electronics (DC 24 V)
- Changes in the configuration level
- Internal voltage supply that is missing or too small
- Setup of data transfer to the device
- Device temperature greater than 115 °C

External The IPC 300 can also be switched off via the "Inhibit" digital input

⇒ Chapter 3.4 "Switch-on sequence"

or via the RS422/485 interface.



Caution!

The firing pulse inhibit does not disconnect the load.

The load connection terminals are at mains potential as the IPC 300 does **not** galvanically isolate the voltage supply!

6 Special device functions

6.8 External current sensors

6.8.1 Error current

The system is to be monitored for an error current using an ext. current sensor.

- * Install and connect the current sensor in the mains lines

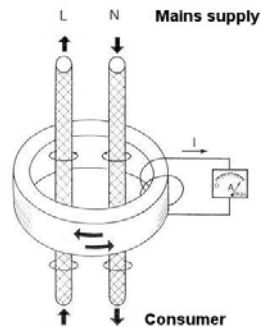

- * Select measurand (error current)
- * Configure standard signal that matches current sensor (0 to 20 mA).
- * Select sensor input measuring range (0 to 500 mA)
- * Set limit value at which there should be an error message.



When the error current limit value is exceeded, only a warning/error message is output that the customer must then process as appropriate. The system is not automatically switched off.

Error message

For a set error current limit value of 100 mA, the error message appears at the bottom of the display.

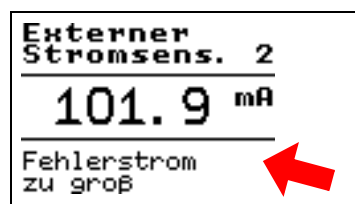

6 Special device functions

6.8.2 Load monitoring

The load monitoring with power reduction serves to protect the components/system. If, during operation with 3 load strands, a load failure occurs, the current that would have flowed in this strand is additionally distributed to the two remaining load strands (Kirchhoff's law) and could therefore damage or even destroy the heating elements used there (in the event of excess current).

The IPC 300 has an internal current sensor which measures the total current. In addition, it is possible to connect up to two external current sensors to monitor individual load lines (up to three load lines).

The external current sensors are designated 2 and 3, because for load line 1 is calculated (virtual current sensor).

The external current sensors can be connected to the IPC 300 as follows and have three different configuration options:

- Error current
- **Load current**
- Mains current

To monitor the load, the individual string currents must be measured with the aid of the measured by means of the external current sensors 2 and/or 3. For this purpose at least one external current sensor as load current sensor is required:

- two load lines --> one external current sensor
- three load lines --> two external current sensors

The external current sensors 2 and 3 can be configured for load monitoring in the configuration level with the measured variable load current.

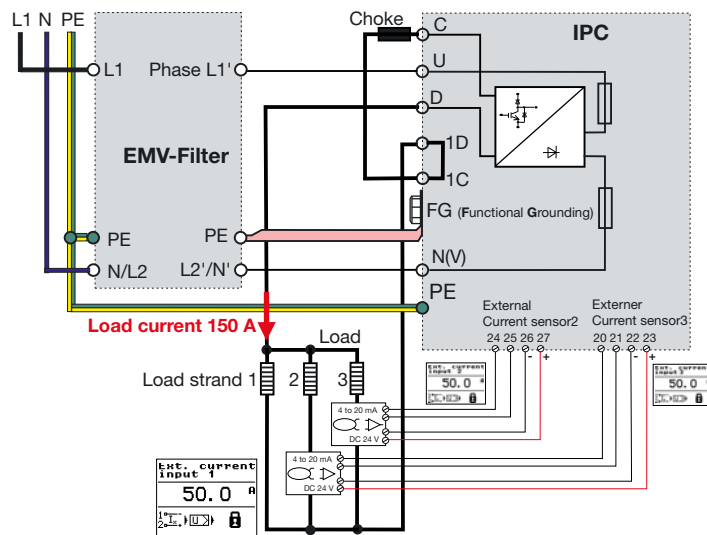

The load current shown in the figure corresponds to the total load current and appears in the measured value overview under the Load current representation. The load current in line 2 is measured by the external current sensor 2 and the load current in line 3 is measured by the external current sensor 3. To avoid having to calculate the load current in string 1, the calculated measured value for string 1 is displayed in the measured value overview in the virtual current sensor1 is displayed.

6 Special device functions

Calculation:

Virtual current sensor = total load current - measured values of external current sensors 2 and 3

Virtual current sensor = 150 A - 50 A - 50 A = 50 A

The current distribution is symmetrical due to equal loads. An average value is stored in the IPC 300 for this good state. This value is monitored for a tolerance range of $\pm 10\%$. The tolerance range is 20% by default ($\pm 10\%$ around the mean value) and can be edited both at the configuration level and through the setup program. The tolerance range is used to compensate for small load imbalances.

If a load change occurs in one line (e.g. due to a load break) so that the tolerance range is exceeded, there is a danger for the remaining load elements, as they are loaded with excessive currents.

The IPC 300 reacts to this by reporting a load break in the relevant line.

The IPC 300 reacts to this by reporting a load failure in the strand affected.

Ext. current
sensor 2

0.0 A

Load error ext.
curr. sensor 2



This means the customer is able to detect the faulty load element and replace it.



In the device the load current limit and the power reduction is set in the Config.level → Ext.current sensors, if at least one of the two Ext. current sensors has been configured as a load current sensor.

Power reduction
Yes

The power reduction activated in this manner automatically reacts when the tolerance range around the average value described above is no longer complied with (load change).

The IPC 300 reduces the power in line with the extent of the load change, thereby protecting the remaining load elements until the component is replaced.

6 Special device functions

6.8.3 Mains current

The mains current sensor serves to monitor the mains current and is placed in the supply line upstream of the EMI filter. A passive current sensor with galvanic isolation must be used.

- * Install and connect current sensor in the voltage supply line

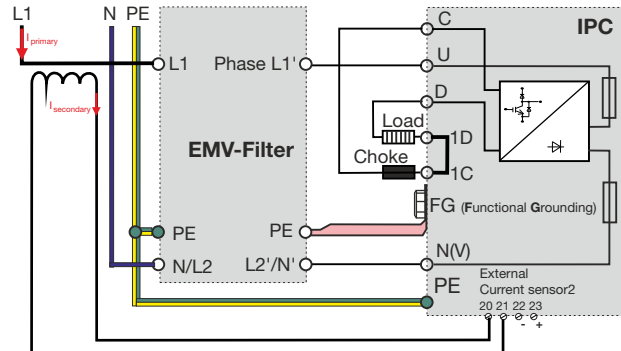

- * Select measurand (mains current)
- * Config.level → Ext.current sensors → Ext.current sensor2 → Measurand → Set mains current
- * Select sensor output signal
- * Config.level → Ext.current sensors → Ext.current sensor2 → Set sensor Outp.Signal e.g. 0 to 20 mA
- * Config.level → Ext.current sensors → Ext.current sensor2 → Set sensorIn-put.Measuring range e.g. 0 to 100 A

The current range 0 to 100 A is thereby assigned to the signal 0 to 20 mA.

Monitoring itself is performed via the limit value monitoring function, where the mains current parameter can be found and has to be set. You can configure the min., max., and hysteresis values here.

⇒ Chapter 5.1.6 "Monitoring"

6 Special device functions

7 Setup program

The setup program enables all data for the device to be configured conveniently on a PC so that it can then be transferred to the device.

7.1 Hardware

- 500 MB free hard disk space
- 512 MB RAM

7.2 Compatible operating systems

- Microsoft Windows® 7 (32/64 bit)
- Microsoft Windows® 8 and 8.1 (32/64 bit)
- Microsoft Windows® 10 (32/64 bit)

Users

 If several users are managed on one computer, make sure that the user who is logged in is the person who will be working with the program later.
The user must have administrator rights for installing the software. After installation, the rights can be restricted again.

Failure to observe this information means that correct and complete installation cannot be guaranteed!

Software versions

The software versions for the device and the setup program must be compatible. An error message will appear if this is not the case!

- * After switching on the device, press 
The device software version is shown in the Device info menu.
- * Click "Info" in the setup program menu bar

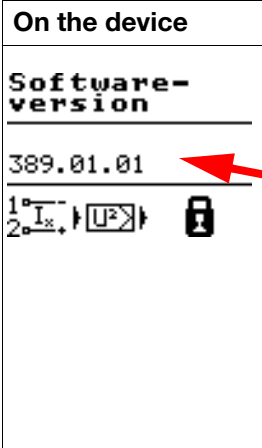
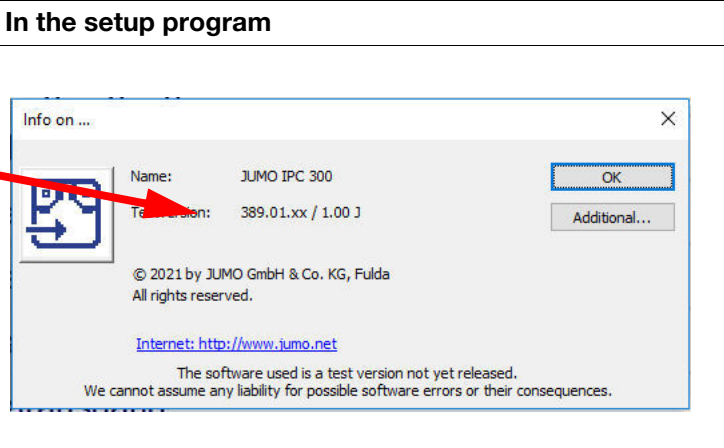
On the device	In the setup program
	

7 Setup program

7.3 Program start

- * Run the setup program using the Windows® start menu
- * Connect the USB micro socket of the power controller to a USB socket on the PC using the supplied cable
- * Click *Connect* in the menu bar



Geräte-Verbindungsliste				
Geräte-Verbindungsliste	Info	Protokoll	Anschluß	1
JUMO IPC 300 - IPC300	Analogwert 31...	A0, 205	USB	09.01.01 - 04

Protocol	Connection
A...	USB

Date	Time	Name	Value
21.05.2021	11:30:42	Device name	IPC300
21.05.2021	11:30:42	Software version	389.01.01
21.05.2021	11:30:42	VdN number	

Diagnostics

The diagnosis window appears at the bottom of the screen and shows the device info and the current measurement data. The connection has been established.



The power controller supplies no power while setup data is being transferred "to the device". The device restarts after the transfer.

8 Error messages and alarms

Cyclical appearance

The symbols for input, subordinate control loop, and operating mode are displayed alternately in the info line together with error messages or information about special statuses.

⇒ Chapter 4.1.2 "Appearance of measured values"

Examples

Unit temperature <hr/> 42 °C <hr/> Min-Alarm	Load resistance <hr/> 38.78 Ω <hr/> Load error	Power <hr/> 0 W <hr/> Fuse breakage
---	---	--

Error message	Cause	Remedy
Min alarm	The value has dropped below the set limit value for the min. alarm	-
Max alarm	The set limit value for the max. alarm has been exceeded	-
Load error	Break or short-circuit of a load resistance. ⇒ Chapter 6.2 "Detection of load faults"	- Replace faulty heating element.
Load failure ext. current sensor 1	The load monitoring via external current sensors has detected a break in the load resistance in the reported branch.	
Load failure ext. current sensor 2		
Load failure ext. current sensor 3		
Teach-In still missing	Reminder that the load monitoring is still inactive because the Teach-In has not yet been performed.	<ul style="list-style-type: none"> - For "manual" Teach-In: Perform Teach-In in operating level or manual mode! - For "Automatically once" or "Automatically (cyclically)" Teach-In: Increase setpoint value so that the minimum output level of 30% is achieved for a Teach-In. ⇒ Chapter 6.2 "Detection of load faults"
Fuse breakage (red fuse LED is lit)	Semiconductor fuse defective	⇒ Chapter 3.4.3 "Replacing the two semiconductor fuses" <ul style="list-style-type: none"> - Check wiring - Check the wire fuse for the load circuit
IGBT breakage	IGBT defective	The device must be returned to JUMO for repair. <ul style="list-style-type: none"> - Return the device

8 Error messages and alarms

Error message	Cause	Remedy
IGBT short circuit	IGBT defective Note: Monitoring only works when the load resistance is so low that $\geq 2\%$ of the power controller nominal current (max. load current) is flowing.	The device must be returned to JUMO for repair. - Return the device
Pre-alarm High temperature	Device temperature is higher than 100 °C (Excess temperature)	- Ensure adequate ventilation or provide for additional cooling
Limitation high temperature	Device temperature is higher than 105 °C. Device is too hot, output level is reduced! (Limited power due to excess temperature)	- Reduce load current - Use power controller with higher maximum load current
Mains voltage too low	DC intermediate circuit voltage is not within specified tolerance range ⇒ Chapter 10.1 "Voltage supply, load current"	- Check configured nominal voltage ⇒ Chapter 5.1.2 "Power controller"
Wire break Current input	Input current too small for the set measuring range.	- Check wiring for wire breaks and reverse polarity. - Check upstream devices (controllers)
Wire break Voltage input	Input voltage too small for the set measuring range.	- Check wiring for wire breaks and reverse polarity. - Check upstream devices (controllers)
Bus error	No connection to Modbus master or Modbus master is inactive.	- Check wiring and master device (PLC). Note: This error message can be suppressed by setting the device address to "0".
SiC voltage reserve used up	This message appears when the power required by the setpoint specification can no longer be reached with the load present.	- Replace SiC heating element ⇒ Chapter 5.1.6 "Monitoring"
Inhibit (inhibit input)	The firing pulse inhibit has been triggered via a PLC level. No power from the power controller.	- Change control direction configuration ⇒ Chapter 5.1.7 "Binary inputs"
Peak current too high -> Inhibit	The current monitoring module has signaled an excessive peak current. To prevent destruction of the device, a firing pulse inhibit is briefly triggered.	- Check wiring of the load circuit. - If the error message is shown permanently, please contact the JUMO Service team!
Inhibit (external input)	The firing pulse inhibit has been triggered via an interface.	⇒ Interface manual "Ext. inhibit"

8 Error messages and alarms

Error message	Cause	Remedy
UCEsat 1 protective switch-off	Error in the power output stage. To prevent destruction of the device, a firing pulse inhibit is triggered permanently.	The device must be returned to JUMO for repair.
UCEsat 2 protective switch-off		
Fault current too high	The error current monitoring using external current sensors has detected that the error current limit value has been exceeded.	Rectify the cause of the error current.
Failure fan 1, 2	Fan 1/2 does not reach the necessary speed.	Check fan for freedom of movement (dirt).
[xxx] Invalid configuration	<p>The value range of a configured parameter has not been complied with. A firing pulse inhibit has therefore been triggered for some parameters.</p> <p>The square brackets contain an ID for the parameter concerned:</p> <ul style="list-style-type: none"> 002 Mains frequency 003 Language wizard active 004 Language 005 Temperature unit 006 Display contrast 007 Switch-off display lighting 008 Apply default settings 010 Subordinate control loop 011 Soft start 012 Soft start duration 013 Voltage supply U-N(V) 014 Customer-spec. voltage 015 Max. load voltage 016 Max. load current 017 Max. power 018 Resistance limitation 019 Max. load resistance 021 Current measuring range 022 Current range start 023 Current range end 024 Voltage measuring range 025 Voltage range, start 026 Voltage range, end 027 Setpoint value config. 028 Setpoint specification 029 Input in the event of an error 030 Value in the event of an error 031 Base load <p>Ext. current sensor 2:</p> <ul style="list-style-type: none"> 034 Measurand 035 Sensor outp. signal 036 Outp. meas. range start 037 Outp. meas. range end 038 Sensor input measuring range 039 Input meas. range start 040 Input meas. range end 041 Limit value error current 	Re-configure the parameter concerned, complying with its value range.

8 Error messages and alarms

Error message	Cause	Remedy
[xxx] Invalid configuration	Ext. current sensor 3: 043 Measurand 044 Sensor outp. signal 045 Outp. meas. range start 046 Outp. meas. range end 047 Sensor input measuring range 048 Input meas. range start 049 Input meas. range end 050 Limit value error current 051 Limit value load current 052 Power reduction 054 Limit value monitoring function 055 Limit value min. alarm 056 Limit value max. alarm 057 Limit value hysteresis 058 Load monitoring 059 Limit value load mon. 060 Teach-In type load mon. 061 Load mon. Teach-In 062 SiC monitoring 064 Changeover setpt. spec. 065 Setpoint specification for changeover 066 Setpoint value for changeover 067 Keyboard lock 068 Ext. switch-off display lighting 069 Ext. Teach-In load mon. 070 Control direction inhibit inpt. 071 Control direction dig. inpt. 1 072 Control direction dig. inpt. 2 074 Output mode digital outp. 075 Control direction dig. outp. 080 Signal type analog outp. 081 Value to be output 082 Signal range start value 083 Signal range end value 085 Baud rate 086 Data format 087 Device address 088 Min. response time 090 Code, manual mode 091 Code, operating lev. 092 Code, config. level 094 Undocument. int. param. 1 143 Undocument. int. param. 50 145 Undocument. float param. 1 169 Undocument. float param. 50	
Wire break ext. current sensor 2, 3	Input current/voltage at external current sensor 2/3 too small for the set measuring range.	Check wiring of the external current sensor for wire breaks and reverse polarity
Config. error ext. current sensor	During configuration of the external current sensor a contradiction was detected.	The affected current sensor has to be configured correctly.

8.1 Binary signal for collective fault

This signal is used for controlling the digital output and LED K1, and can also be read out via the interfaces of the power controller.

You can use the setup program to configure which events (alarm and error messages) are to be grouped together as a binary signal for the collective fault.

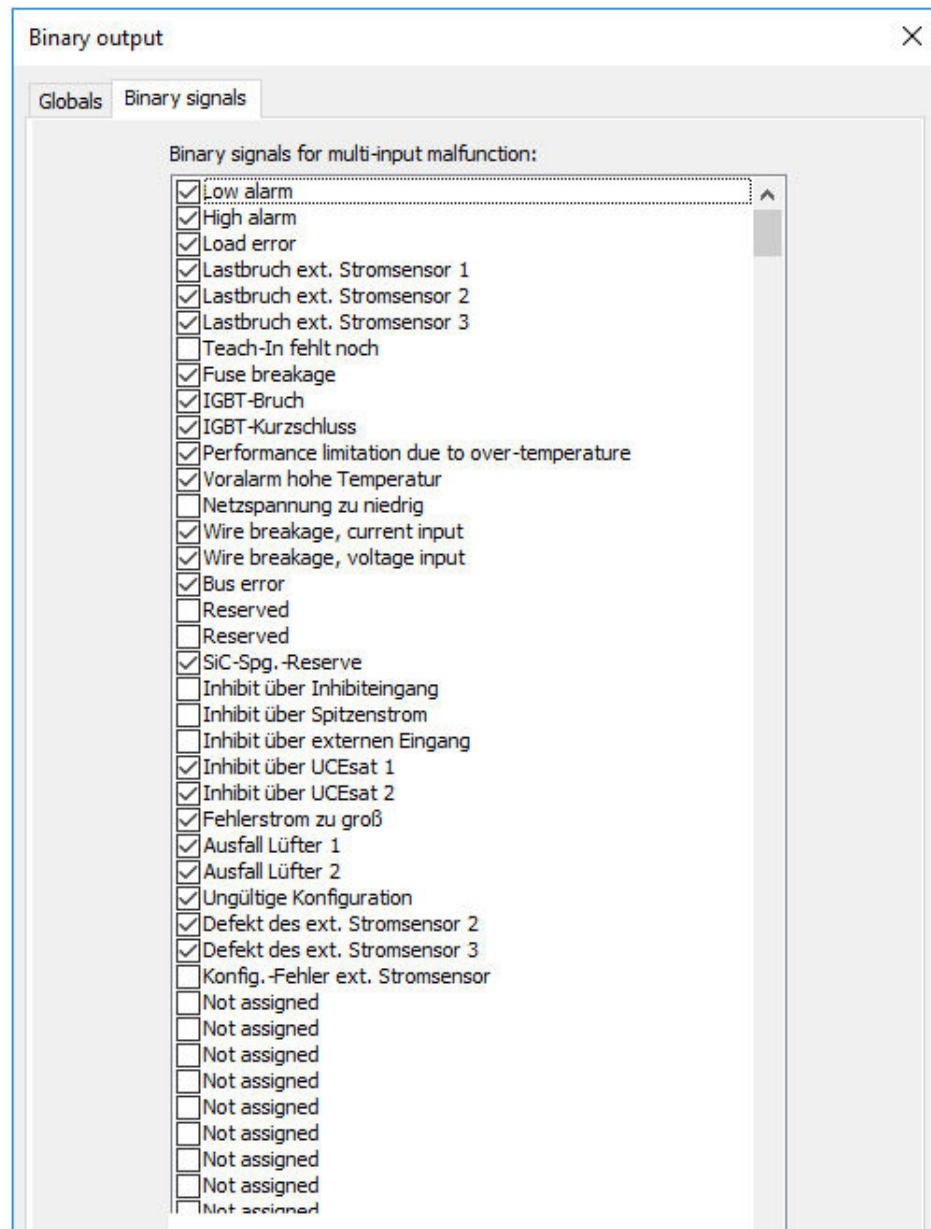

All fault messages are OR-linked and output as a binary signal for a collective fault on the relay output or optocoupler.

In addition, LED K1 lights up yellow.

This alarm can switch a relay at the digital output.

⇒ Chapter 5.1.8 "Binary output"



8 Error messages and alarms

What is happening?	Cause / remedy	Info
Power controller is not producing any output power even though the green Power LED is lit and a setpoint value has been set.	- Parameters have been changed in the configuration level but not completed. * Leave the configuration level by pressing EXIT and wait for a restart.	-
	- Wire break at the analog input or incorrect analog input wiring	⇒ Chapter 3.4 "Switch-on sequence"
	- Setpoint value configuration incorrectly configured, e.g. set via interface.	⇒ Chapter 5.1.4 "Setpoint configuration"
	- Input for firing pulse inhibit active A padlock symbol is shown as the operating mode in the info line.	⇒ Chapter 4.1.2 "Appearance of measured values"
	- Load failure * Check load and load connections	⇒ Chapter 8 "Error messages and alarms"
Fuse LED is lit	- Semiconductor fuse defective due to short circuit in power section * Remedy short circuit in the load or load circuit * Fit a new semiconductor fuse	⇒ Chapter 3.4.3 "Replacing the two semiconductor fuses"
Power controller is producing power even though no setpoint value (output level) is specified by the controller.	- Configuration problem: Controller output signal set to 4 to 20 mA and current set to 0 to 20 mA at analog input of power controller. * Check configuration and select same standard signals for the controller and power controller.	⇒ Chapter 5.1.3 "Analog inputs" ⇒ Chapter 5.1.4 "Setpoint configuration"
	- Power controller in manual mode * Exit manual mode by pressing EXIT	⇒ Chapter 6.3 "Manual mode"
	- Base load settings selected * Check settings for base load settings	⇒ See "" on page 54.
	- IGBT short-circuit	⇒ Chapter 8 "Error messages and alarms"

9 What to do, if ...

What is happening?	Cause / remedy	Info
Power controller is not producing full power even though the setpoint value is set to 100 %	Here, the following limits may be active: <ul style="list-style-type: none">- Voltage limitation- Current limiting active- Resistance limitation- Power limitation * Check settings	⇒ See "Max. load voltage" on page 51.

10.1 Voltage supply, load current

	Type 709051-X-XX-70 and 100	Type 709051-X-XX-200
Voltage supply for control electronics	DC 24 V +15 %/ -20 % SELV	
Power consumption of the control electronics	max. 25 W	
Voltage supply for power section	AC 20 to 400 V +15 %/ -20 %, 48 to 63Hz	
Load voltage $U_{L\text{ eff}}$  (freely adjustable)	at AC 400 V supply to power section. Load voltage up to max. DC 380 V at AC 230 V supply, max. DC 210 V at AC 115 V supply, max. DC 90 V	
Load current $I_{L\text{ eff}}$ 	DC 70 A / 100 A	DC 200 A
maximum power in 230 V mains voltage	$U_{\text{ Mains voltage: 230 V, } I_{\text{ Load 70 A: 14.7 kW}}$ $U_{\text{ Mains voltage: 230 V, } I_{\text{ Load 100 A: 21 kW}}$	$U_{\text{ Mains voltage: 230 V, } I_{\text{ Load 200 A: 21 kW}}$ Reason: the mains current is limited to 100 A through the EMI filter.
maximum power in 400 V mains voltage	$U_{\text{ Mains voltage: 400 V, } I_{\text{ Load 70 A: 26.6 kW}}$ $U_{\text{ Mains voltage: 400 V, } I_{\text{ Load 100 A: 38 kW}}$	$U_{\text{ Mains voltage: 400 V, } I_{\text{ Load 200 A: 38 kW}}$ Reason: the mains current is limited to 100 A through the EMI filter.
Load type	Resistive loads	

10.2 Analog inputs

Current	0 (4) to 20 mA $R_i = 50 \Omega$
Voltage	0 (2) to 10 V $R_i = 25 \text{ k}\Omega$
	0 (1) to 5 V $R_i = 25 \text{ k}\Omega$

10.3 Analog output

Analog output	Switched off as standard. For standard signal voltage 0(2) to 10V, 0(1) to 5 V: $I_{\text{ max}} = 20 \text{ mA}$. For standard signal current 0(4) to 20 mA: Burden max. 500 Ω Various internal measurands such as load current, load voltage, or power can be output.
---------------	--

10.3.1 Display and measuring accuracy

All specifications refer to the power controller nominal data.

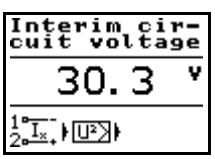
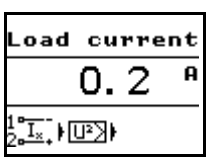
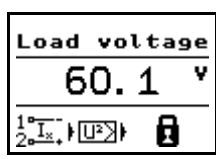
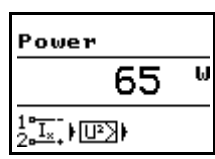
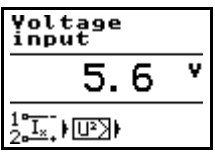
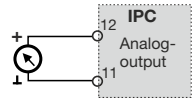
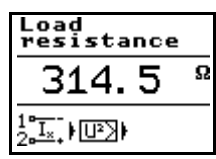
DC intermediate circuit voltage: $\pm 2.5\%$ 	Load current: $\pm 1\%$ 	Load voltage: $\pm 1\%$ 	Power: $\pm 2\%$ 
Analog input voltage/current: $\pm 1\%$ 	Analog output Voltage/current: $\pm 1\%$ 	Load resistance: $\pm 2\%$ (For resistive load) 	

10 Technical data

10.4 Digital inputs

Digital input 1	For connection to PLC level
Digital input 2	

10.5 Digital output

Relay (changeover contact) without contact protection circuit	30000 switching operations at a switching capacity of AC 230V/3 A(1.5 A) 50 Hz
Optocoupler output	$I_{Cmax} = 2 \text{ mA}$, $U_{CEOmax} = 32 \text{ V}$

10.6 General specifications

	Type 709051-X-XX-70 and 100	Type 709051-X-XX-200
Circuit variants	Single-phase operation	
Operating modes	Amplitude control	
Subordinate control loop	U-, U ² -, I-, I ² - and P control configurable as a standard feature	
Current limiting	In operation, the load current can be configured in the range of 10 to 100 % I _N on the front panel. This limits the effective value of the load current.	
Load monitoring	Detection of partial load failure or load short circuit	
R control	Setting range from R _{Nom} to 10x R _{Nom} , R _{Nom} = nominal voltage / nominal current	
SiC reserve	Message indicating when the voltage reserve for SiC heating rods is exhausted	
Analog output	Standard signal 0/4 to 20 mA, 0/2 to 10 V or 0/1 to 5 V Output value configurable	
Control accuracy	The regulation will eliminate voltage supply variations within the tolerance range (+15 %/ -20 %) with an accuracy of ± 0.5 %	
Electrical connection	Control cables via pluggable screw terminals for conductor cross sections 0.5 to 2.5 mm ²	
	in power section screw terminals 10 mm ² to 50 mm ²	in power section screw terminals U, PE, N(V) : 10 mm ² to 50 mm ² Screw terminals C, D 1D, 1C: 30 mm ² to 95 mm ²
Semiconductor fuse	The I ² t value (operating integral) of the fuses integrated into the device must be less than 20000 A ² s.	
Protection type	IP 20 according to EN 60529	
Protection rating	Protection rating I, with isolated control circuitry for connection to SELV circuits	
Admissible ambient temperature range	5 to 40 °C (3K3 according to EN 60 721-3-3)	
Admissible storage temperature range	-10 to +70 °C (1K3 according to EN 60 721-3-1)	
Cooling	forced convection, maximum inlet air temperature 35 °C	
Resistance to climatic conditions	rel. humidity ≤ 5 to 85 % annual average, without condensation 3K3 according to EN 60 721	
Installation position	Vertical	
Operating conditions	The power controller is designed as a built-in device according to: EN 50178, pollution degree 2, overvoltage category Ü III	
Altitude	≤ 2000 m above MSL	
Electromagnetic compatibility	according to DIN 61326 Interference emission: class A - only for industrial use. Interference immunity: industrial requirements	
Test voltage	According to EN 50178	
Creepage distances	Control electronics to load circuit ≥ 5.5 mm, control electronics to housing ≥ 5.5 mm, device can be connected to SELV circuits. SELV = Separate Extra Low Voltage (safe low voltage)	

10 Technical data

Leakage current	The leakage current of the IPC 300 with upstream EMI filter (excluding the leakage current in the load) is less than 3 mA.	
Housing	Metal case	
Scope of delivery	1 operating manual	
Digital output: relay (changeover contact) without contact protection circuit	30000 switching operations at a switching capacity of 3 A/230 V 50 Hz resistive load	
Optocoupler output	$I_{Cmax} = 2 \text{ mA}$, $U_{CE0max} = 32 \text{ V}$	
Dimensions: (length x width x height)	(348.6 x 300 x 217) mm	(403.5 x 300 x 257.5) mm
Weight	Approx. 16 kg	Approx. 21.5 kg

10 Technical data

11.1 China RoHS

  <small>More than sensors + automation</small>							
产品组别 Product group: 709051		产品中有害物质的名称及含量 China EEP Hazardous Substances Information					
部件名称 Component Name		铅 (Pb)	汞 (Hg)	镉 (Cd)	六价铬 (Cr(VI))	多溴联苯 (PBB)	多溴二苯醚 (PBDE)
外壳 Housing (Gehäuse)		X	○	○	○	○	○
过程连接 Process connection (Prozessanschluss)		○	○	○	○	○	○
螺母 Nuts (Mutter)		○	○	○	○	○	○
螺栓 Screw (Schraube)		○	○	○	○	○	○

本表格依据SJ/T 11364的规定编制。
 This table is prepared in accordance with the provisions SJ/T 11364.
 ○ : 表示该有害物质在该部件所有均质材料中的含量均在GB/T 26572规定的限量要求以下。
 Indicate the hazardous substances in all homogeneous materials' for the part is below the limit of the GB/T 26572.
 × : 表示该有害物质至少在该部件的某一均质材料中的含量超出GB/T 26572规定的限量要求。
 Indicate the hazardous substances in at least one homogeneous materials' of the part is exceeded the limit of the GB/T 26572.

11 Certificate



JUMO GmbH & Co. KG

Street address:
Moritz-Juchheim-Straße 1
36039 Fulda, Germany
Delivery address:
Mackenrodtstraße 14
36039 Fulda, Germany
Postal address:
36035 Fulda, Germany
Phone: +49 661 6003-0
Fax: +49 661 6003-607
Email: mail@jumo.net
Internet: www.jumo.net

JUMO Instrument Co. Ltd.

JUMO House
Temple Bank, Riverway
Harlow, Essex, CM20 2DY, UK
Phone: +44 1279 63 55 33
Fax: +44 1279 62 50 29
Email: sales@jumo.co.uk
Internet: www.jumo.co.uk

JUMO Process Control, Inc.

6724 Joy Road
East Syracuse, NY 13057, USA
Phone: +1 315 437 5866
Fax: +1 315 437 5860
Email: info.us@jumo.net
Internet: www.jumousa.com

