

# JUMO I/O system

## 16-channel digital input module

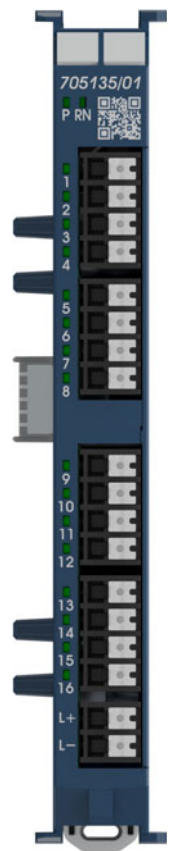

Operating Manual

70513500T90Z001K000

V1.00/EN/2025-04-16



**Further information and downloads**



[qr-705135-en.jumo.info](https://qr-705135-en.jumo.info)

# Table of contents

---

<b>1</b>	<b>About this documentation</b>	<b>5</b>
1.1	Validity	5
1.2	Applicable documentation	5
1.3	Purpose	5
1.4	Target group	5
1.5	Trademark information	5
1.6	Symbols	5
<b>2</b>	<b>Safety</b>	<b>7</b>
2.1	Intended use	7
2.2	Qualification of personnel	7
2.3	Transport and storage damage	7
2.4	Cleaning	7
<b>3</b>	<b>Description</b>	<b>8</b>
3.1	Design and function	8
3.2	Display and connection elements	9
3.3	Nameplate	10
3.4	Approval marks and certificates	10
3.5	Scope of delivery	10
<b>4</b>	<b>Technical data</b>	<b>11</b>
4.1	Electrical data	11
4.2	Digital inputs	11
4.3	Electrical isolation	11
4.4	Environmental influences	12
4.5	Mechanical features	12
4.6	Dimensions	13
<b>5</b>	<b>Mounting</b>	<b>14</b>
5.1	Prepare mounting	14
5.2	Mounting the module	17
<b>6</b>	<b>Electrical connection</b>	<b>18</b>
6.1	Preparing the electrical connection	18
6.2	Connection elements	19
6.3	Connection diagram	20
6.3.1	Digital inputs	20
<b>7</b>	<b>Startup</b>	<b>21</b>

---

# Table of contents

---

<b>8</b>	<b>Configuration</b> .....	<b>..22</b>
8.1	Device configuration .....	..22
8.2	Process values .....	..22
<b>9</b>	<b>Shutdown</b> .....	<b>..24</b>
9.1	Dismounting .....	..24
9.2	Returns .....	..25
9.3	Disposal .....	..25
<b>10</b>	<b>Accessories</b> .....	<b>..26</b>

# 1 About this documentation

---

## 1.1 Validity

This documentation applies to this module (7051xx) of the JUMO I/O system for all software and hardware versions of the module. If a module function depends on a particular software or hardware version, the documentation shall point this out.

Use of the module together with a central processing unit of the JUMO variTRON automation system is supported by the central processing unit from system version 9.

In this documentation, the terms "device" and "module" are synonymous.

## 1.2 Applicable documentation

This module of the JUMO I/O system is used within an automation system together with other modules and a central processing unit. The operating manual for the respective central processing unit is considered an applicable publication which is required to use this module:

- JUMO variTRON 300 operating manual (document 70500300T90...)
- JUMO variTRON 500 operating manual (document 70500200T90...)
- JUMO variTRON 500 touch operating manual (document 70500400T90...)

## 1.3 Purpose

This documentation is part of the device and includes all information to ensure that it is used safely and as intended across all phases of the product lifecycle.

If you do not follow the documentation and safety information, this may result in risk to life and damage to property due to improper use.

- Read and follow the documentation and the safety information and warnings.
- Store the document in its entirety, in an easily accessible location, and so that it can be read in full at all times.
- Contact the manufacturer if you have any questions about the device and documentation.

## 1.4 Target group

This documentation is intended for trained electrical, mechanical, and plant engineering personnel.

⇒ chapter 2.2 "Qualification of personnel", Page 7

## 1.5 Trademark information

All trademarks and trade and company names used are the property of their rightful owners or authors.

## 1.6 Symbols



### **WARNING!**

**The signal word "WARNING" indicates an imminent danger.**

Non-observance can lead to death or serious injury.

- ▶ The instructions in the warning notice must be observed and followed!
- 



### **DANGER!**

**The signal word "DANGER" indicates an immediate danger.**

Non-observance will lead to death or serious injury.

- ▶ The instructions in the warning notice must be observed and followed!
-

# 1 About this documentation

---



## CAUTION!

The signal word "CAUTION" indicates an imminent danger.

Non-observance can lead to minor or moderate injury.

- ▶ The instructions in the warning notice must be observed and followed!
- 

## NOTICE!

The signal word "NOTICE" indicates possible damage to property.

Non-observance can lead to damage to devices, systems or the environment.

- ▶ Observe the instructions in the note for avoiding damage!
- 



## NOTE!

This symbol refers to important information about the device or its handling.

---



## NOTE!

This symbol is used in tables and indicates that further information is provided after the table.

---



## REFERENCE!

This symbol refers to **further information** in other sections, chapters, or other manuals.

---

### 2.1 Intended use

The 16-channel digital input module (705135) is a module of the JUMO I/O system (7051xx) and provides 16 digital inputs (DC 0/24 V) for the JUMO variTRON automation system (7050xx). It is suitable for indoor use and is installed on a DIN rail inside a control cabinet.

The documentation is part of the device. The device is only intended for use according to this documentation.

### 2.2 Qualification of personnel

The personnel deployed must meet the following requirements in all phases of the product lifecycle:

- Trained electrical, mechanical, and plant engineering personnel.
- Members of personnel are familiar with this documentation and the safety information and warnings it contains.

### 2.3 Transport and storage damage

The device can be damaged if it is insufficiently protected during transport and/or improperly stored.

- Transport the device protected from moisture and dirt in shockproof packaging.
- Protect all electrical and mechanical connections from damage.
- Observe the admissible storage temperature of the device.
- Store the device in a dry and dust-free environment.

### 2.4 Cleaning

Only use a dry cloth for cleaning the device (protection type IP20).

# 3 Description

---

## 3.1 Design and function

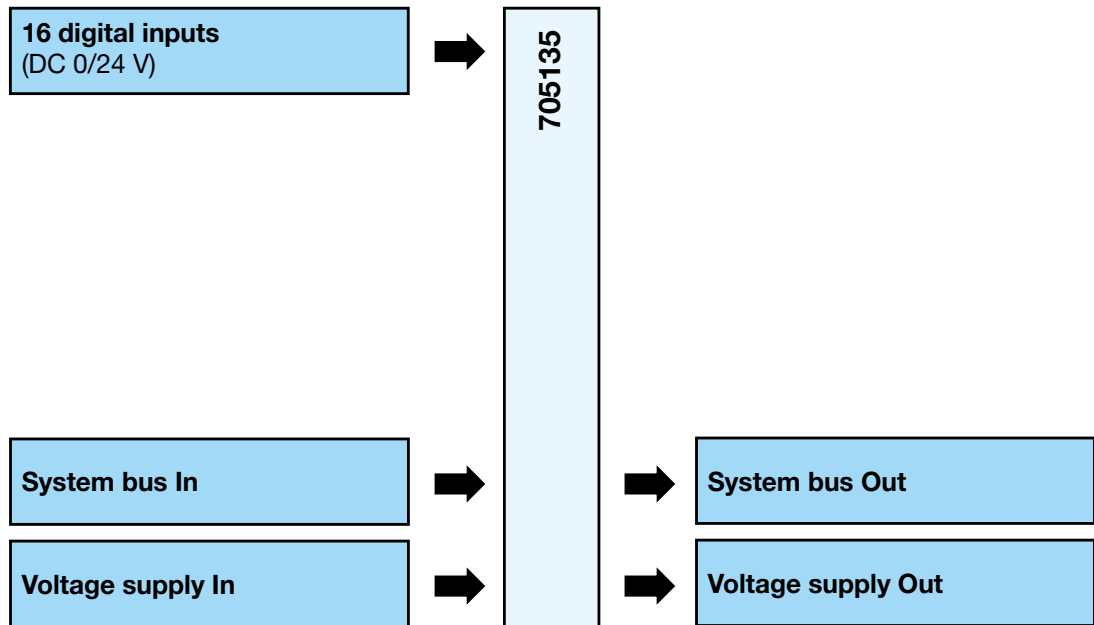

The 16-channel digital input module (705135) is a module of the JUMO I/O system (7051xx) and provides 16 digital inputs (DC 0/24 V) for the JUMO variTRON automation system (7050xx). It is suitable for indoor use and is installed on a DIN rail inside a control cabinet.

The 16-channel digital input module is intended for operation on a central processing unit of the JUMO variTRON automation system. A system module (705171) is required for direct connection to JUMO variTRON 500; a 3-channel communication module (705163) is required for connection to JUMO variTRON 300 and 500 touch.

The 16-channel digital input module can be operated on a third-party PLC if it supports the JUMO system bus. A 3-channel communication module is also required for this.

The 16-channel digital input module is connected to the adjacent modules via the side plug connectors. The plug connector on the left-hand side of the housing establishes the connection to the system's voltage supply and the system bus. The voltage supply and the system bus for the next module are provided via the plug connector on the right-hand side of the housing.

The status of the module (voltage supply, EtherCAT Slave) and the status of each digital input (active/inactive) are indicated by LEDs. The digitalized input states are transmitted to the central processing unit via the system bus and are available there for further processing.

The JUMO smartWARE Setup variTRON PC program is available to configure the module. The module can also be configured using the JUMO variTRON Web Cockpit web application.

## 3.2 Display and connection elements

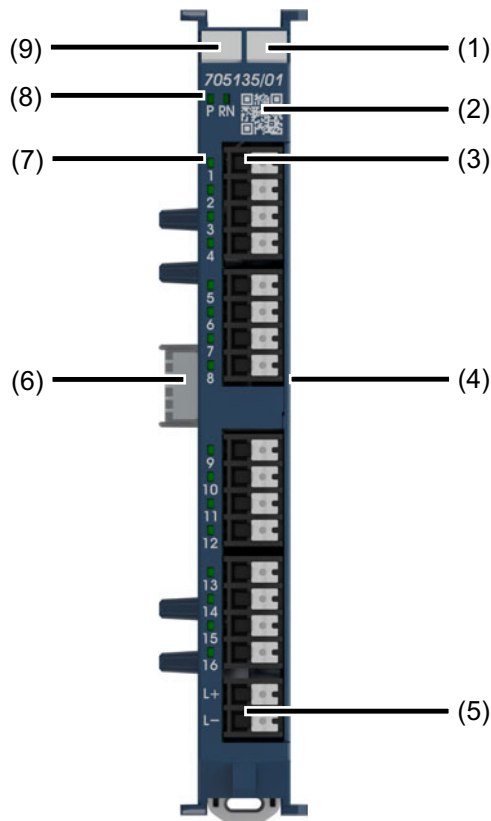

- 1 Space for inscription label (not included in scope of delivery)
- 2 QR code (web link to JUMO product page)
- 3 Connection terminal for digital input (here: input 1)
- 4 Plug connector (socket, side) for Out voltage supply and EtherCAT Out system bus
- 5 Connection terminal for reference potential (GND) of the digital inputs
- 6 Plug connector (side) for In voltage supply In and EtherCAT In system bus
- 7 Status display of the digital input (lights up = input signal active)
- 8 Status display of the module (P = Power, RN = Run)
- 9 Space for inscription label (not included in scope of delivery)

## 3 Description

### 3.3 Nameplate

The specifications on the nameplate are for device identification purposes.

#### Position

The nameplate is located on the left side of the housing (label or laser marking).

#### Contents

The nameplate contains important information. This includes:

Description	Designation on the nameplate	Example
Device type	Type	705135/01-0-66-36/000
Part no. (material number)	TN	30012345
Fabrication number	F-No.	0070033801224390006
Voltage supply	-	DC 24 V, +25/-20 %

#### Device type (type)

Compare the specifications on the nameplate with the order.

Identify the supplied device version using the order details (order code).

#### Part no. (material number) (TN)

The part no. (material number) uniquely identifies an article. It is important for communication between the customer and the sales department.

#### Fabrication number (F-No.)



The fabrication number indicates, among other things, the date of manufacture (year/week).

Example: F-No. =007003380122**439**0006

The characters in question are digits 12, 13, 14, and 15 (from the left).

The device was therefore produced in the 39th week of 2024.

### 3.4 Approval marks and certificates

	Designation Test facility Certificate no. Inspection basis Valid for	DNV® DNV® Submitted Class Guidelines CG 0339 Module with extra code 062
	Designation Test facility Certificate no. Inspection basis Valid for	UL Underwriters Laboratories Submitted CAN/CSA-C22.2 No. 61010-1-12 (3rd Ed.) / UL 61010-1 (3rd Ed.) All versions of the module

### 3.5 Scope of delivery

1 module in the ordered version
1 documentation

## 4.1 Electrical data

Voltage supply Connection	Side (supply via central processing unit with system module or via communication module)
Voltage Residual ripple	DC 24 V +25/-20 % SELV 5 %
Current consumption	0.1 A (at 19.2 V)
Power consumption	1.5 W (module electronics only) 13.44 W (max.)
Electrical safety	According to DIN EN 61010-1:2020 Overvoltage category III, pollution degree 2

## 4.2 Digital inputs

Number	16
Connection	At the front (terminals with PUSH IN technology)
Input signal	DC 0/24 V (PLC level; logic level "0" = -3 to +5 V; logic level "1" = +15 to +30 V)
Current	Max. 5 mA per input
Conductor cross section	
Wire or stranded wire	Min. 0.25 mm <sup>2</sup> , max. 1.5 mm <sup>2</sup>
Stranded wire with ferrule	
Without plastic collar	Min. 0.25 mm <sup>2</sup> , max. 1.5 mm <sup>2</sup>
With plastic collar	Min. 0.25 mm <sup>2</sup> , max. 0.75 mm <sup>2</sup>
Stripping length	8 to 10 mm

## 4.3 Electrical isolation

	a	Functional galvanic isolation for the connection of SELV or PELV electrical circuits
	1	EtherCAT (side) Out system bus
	2	Voltage supply (side) Out
	3	Voltage supply (side) In
	4	EtherCAT (side) In system bus
	5	Reference potential L- (GND) for digital inputs
6	Digital inputs	To ensure galvanic isolation, the input signals must be fed from a separate power supply unit whose secondary side is galvanically isolated from the system's voltage supply.

## 4 Technical data

---

### 4.4 Environmental influences

Storage conditions	1K21 according to DIN EN 60721-3-1:2018-12
Temperature range (expanded)	-40 to +70 °C
Operating conditions	3K22 according to DIN EN 60721-3-3:2018-12
Temperature range (expanded)	-20 to +55 °C
Relative humidity (expanded)	≤ 90 % without condensation
Vibration resistance	According to DIN EN 60068-2-6:2008-10
Amplitude	0.15 mm from 10 to 58.1 Hz
Acceleration	20 m/s <sup>2</sup> from 58.1 to 150 Hz
Shock resistance	According to DIN EN 60068-2-27:2010-02
Peak acceleration	150 m/s <sup>2</sup>
Shock duration	11 ms
Shock resistance	IK06 according to DIN EN 62262:2022-02
Site altitude	Max. 2000 m above sea level
Protection type	IP20 according to DIN EN 60529:2014-09
Electromagnetic compatibility	According to DIN EN 61326-1:2022-11
Interference emission	Class A – only for industrial use –
Interference immunity	Industrial requirement

### 4.5 Mechanical features

Housing type	Plastic housing for DIN-rail mounting in the control cabinet (indoor use); DIN rail according to DIN EN 60715, 35 mm × 7.5 mm × 1 mm
Weight	Approx. 90 g

## 4.6 Dimensions

### Module with PCB terminal blocks

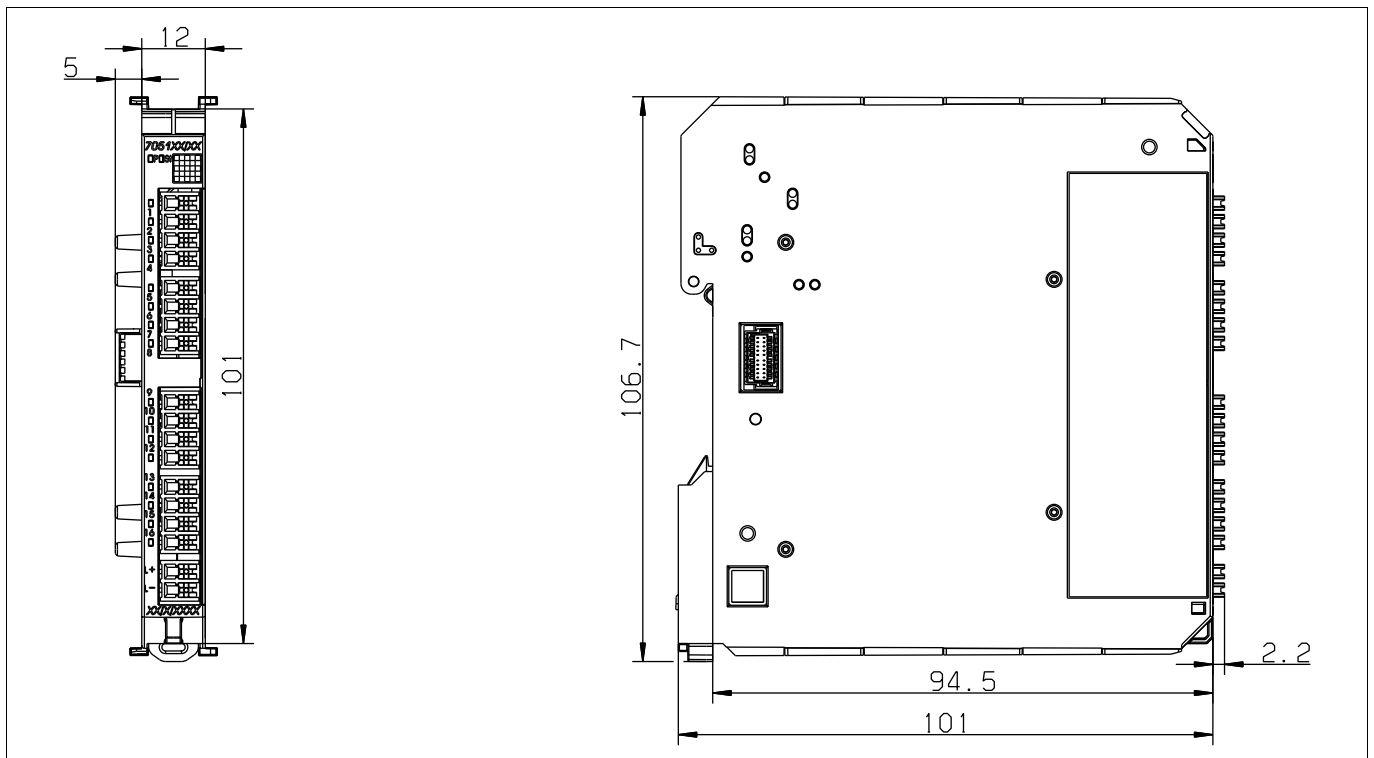

### Module with pluggable terminals (circuit board plug connectors)

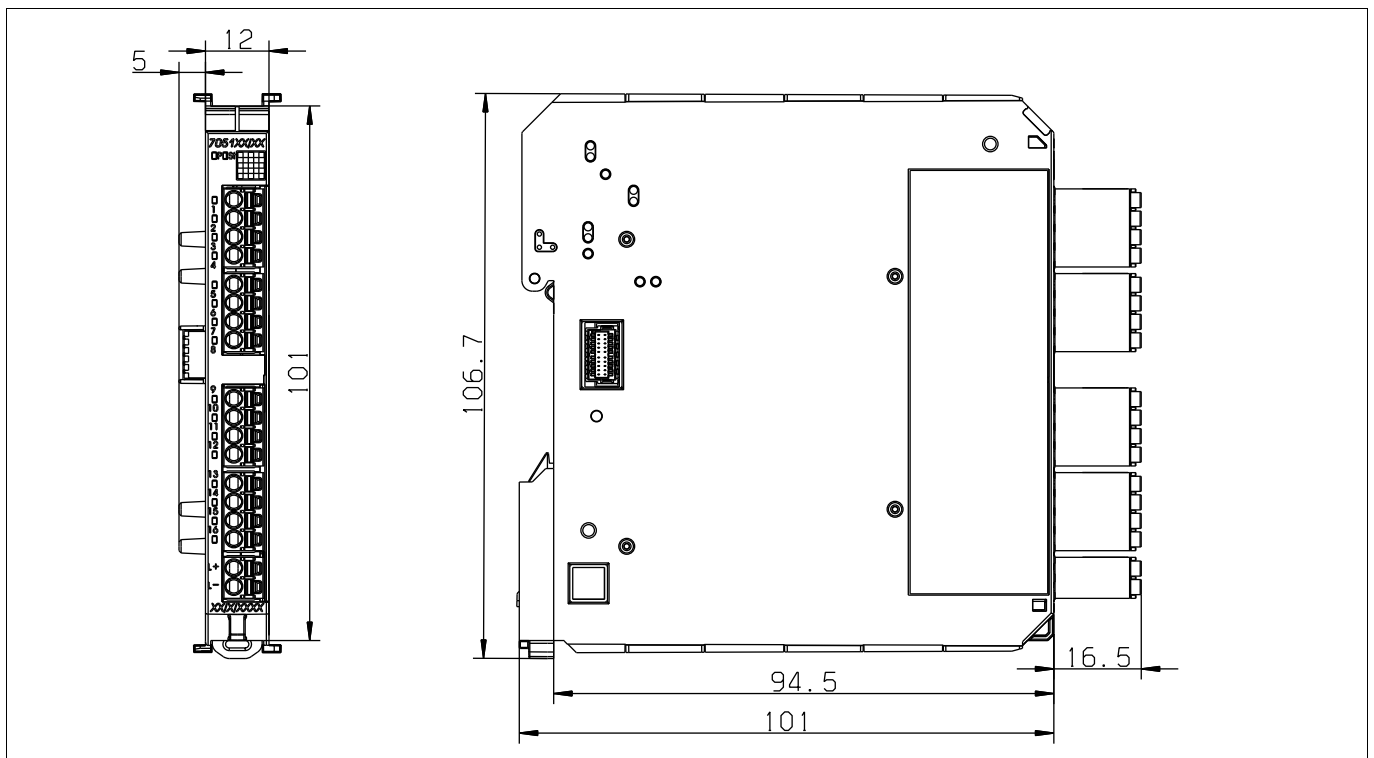

# 5 Mounting

---

## 5.1 Prepare mounting

### Warnings



#### **DANGER!**

**The load circuits of modules that have relay or solid state relay outputs can be operated with a dangerous electrical voltage (e.g. 230 V).**

There is a risk of electric shock.

- ▶ Before mounting these modules, the load circuits may have to be disconnected from the voltage supply. This work must only be performed by qualified personnel.
- 



#### **WARNING!**

**The modules must never be installed in potentially explosive areas.**

Explosion hazard.

- ▶ The entire system must only be used outside of potentially explosive areas.
- 

### Mounting site

All modules have protection type IP20 and are only intended for use in fireproof control cabinets or switch boxes. The mounting site should be virtually vibration-free. Electromagnetic fields caused by equipment such as motors or transformers should be avoided.

### Climatic conditions

The ambient temperature and the relative humidity at the mounting site must correspond to the technical data. Aggressive gases and steams have a negative effect on the operating life of the modules. The mounting site must be free from dust, powder, and other suspended solids so that the cooling slots do not become blocked.

### DIN rail

All modules are mounted on a DIN rail according to DIN EN 60715 (35 mm × 7.5 mm × 1 mm). For reasons of stability, the spacing of the fastening screws for the DIN rail should not exceed 200 mm. The module-specific minimum distances for the modules must be observed.

To determine the required minimum width of the DIN rail, the widths of the individual modules must be added. In addition, the widths of the end brackets (each 9.5 mm) may have to be taken into consideration.

### Installation position

The DIN rail should be mounted horizontally so that all modules are arranged vertically. Otherwise the admissible ambient temperature range will be restricted.

### Space requirement

The modules require the minimum distances shown in the following figure for the purpose of installation/dismounting and for future maintenance or replacement. In the event of shorter distances the minimum bending radius of the cables, the performance of the electrical installation, and the clear arrangement of the plant are no longer guaranteed.

## Module arrangement

One of the following modules must be mounted on the left next to the first input and output module (7051xx) or the first 2-channel communication module (705162) of the JUMO I/O system:

- a JUMO variTRON 500 central processing unit (705002) and a system module (705171) or
- a 3-channel communication module (705163) or
- a 3-port router module (705042) and a system module (705171) or
- a 1-port router module (705043) and a system module (705171)

These modules connect the modules of the JUMO I/O system (7051xx) to the voltage supply and the system bus.

Modules from the 7050xx series can be arranged between the central processing unit and the system module as well as between a 3-port/1-port router module and the system module.

In general, any order of input and output modules is possible.

## Minimum distances – module with PCB terminal blocks

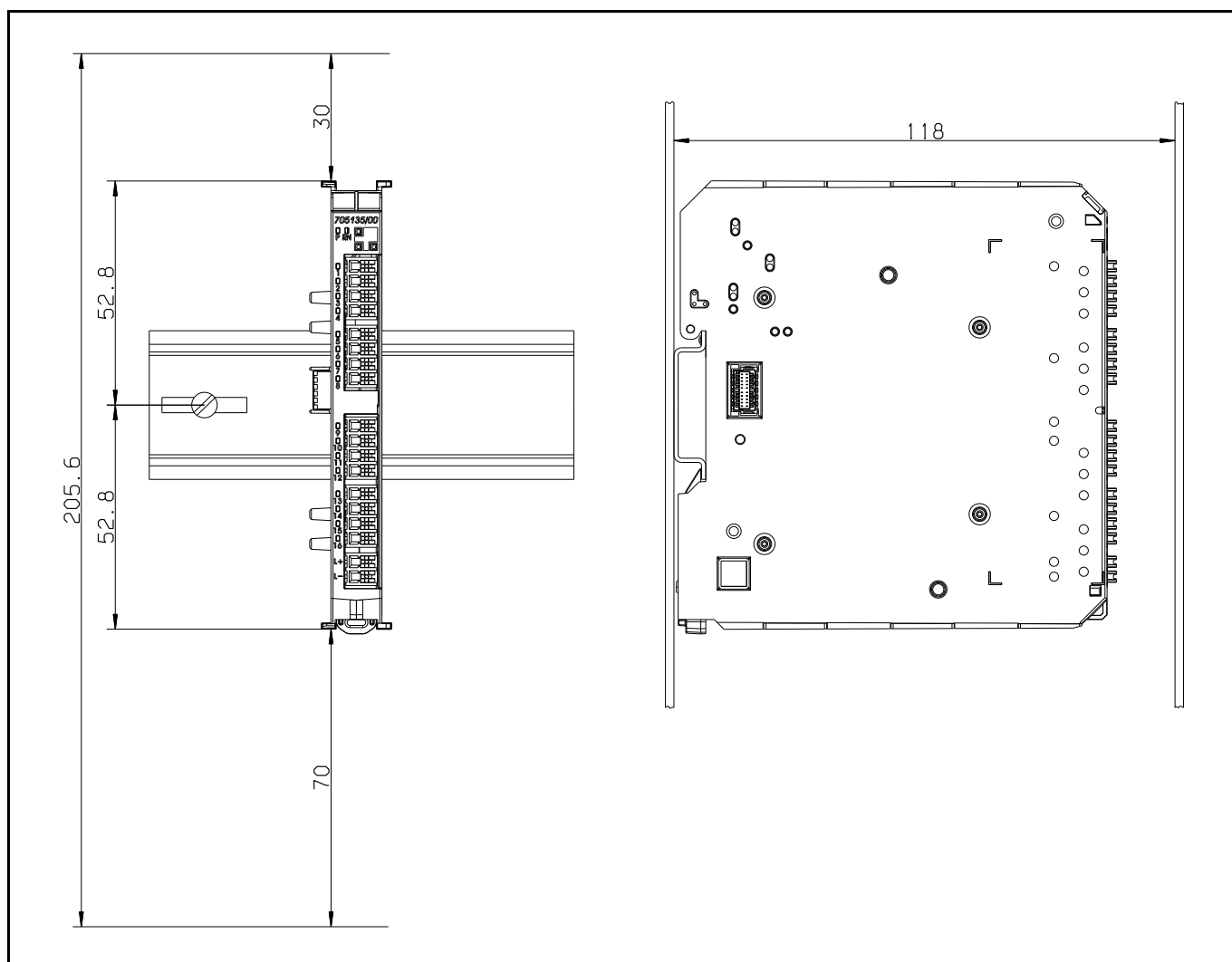

# 5 Mounting

Minimum distances – module with pluggable terminals (circuit board plug connectors)

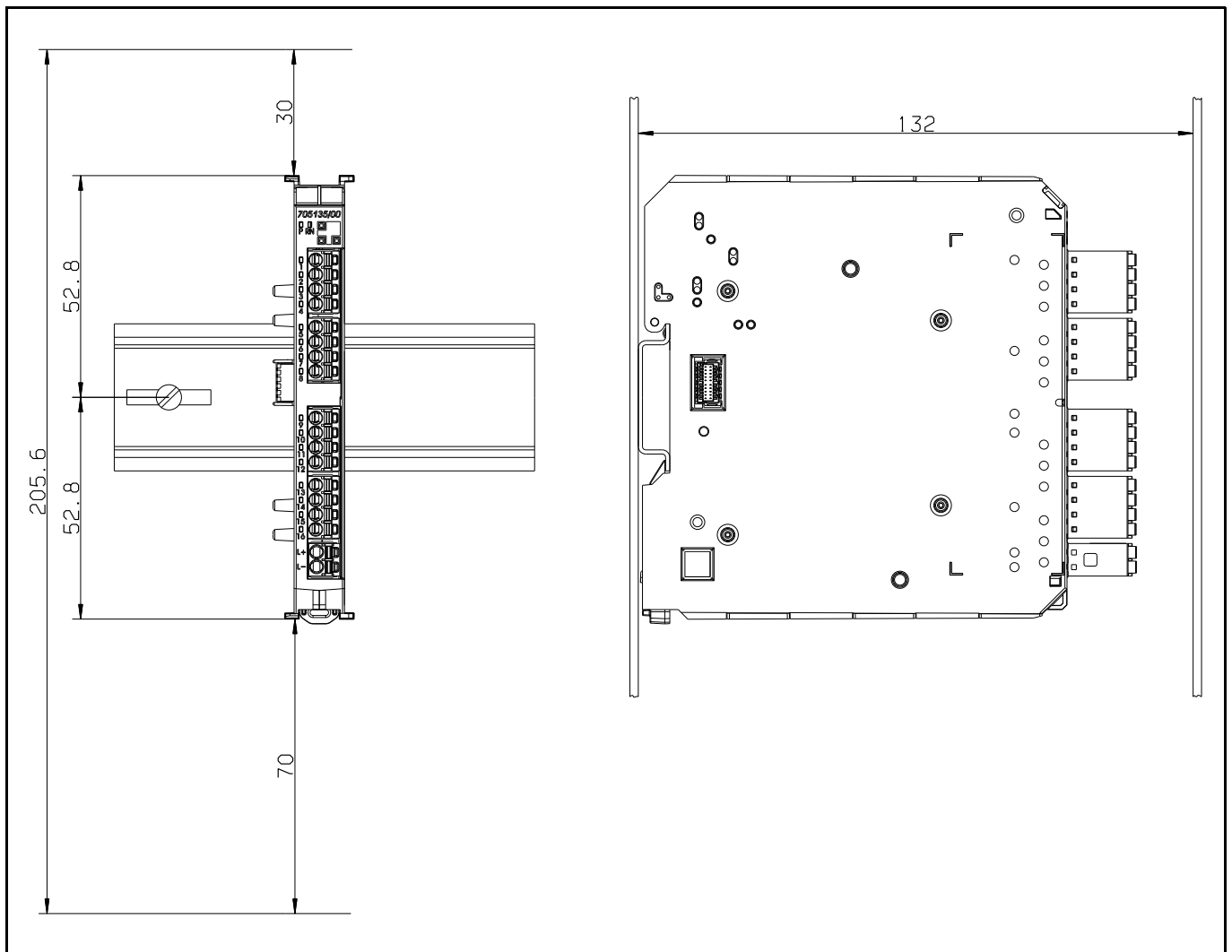

## 5.2 Mounting the module

The example shows the mounting of modules on a previously mounted central processing unit (705002).

### Placing module on DIN rail

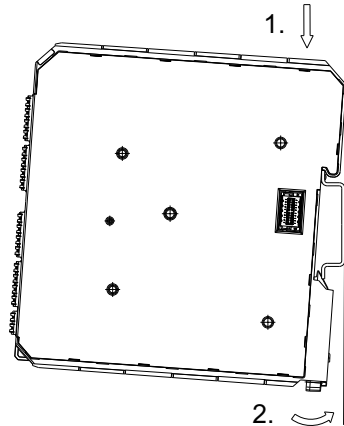

1. Hook the module into the DIN rail from above.
2. Pivot the module downward until it snaps into place.
3. Place all required modules in the same manner on the DIN rail. Observe the order here: In this example a system module (705171) is required first.

### Connecting modules

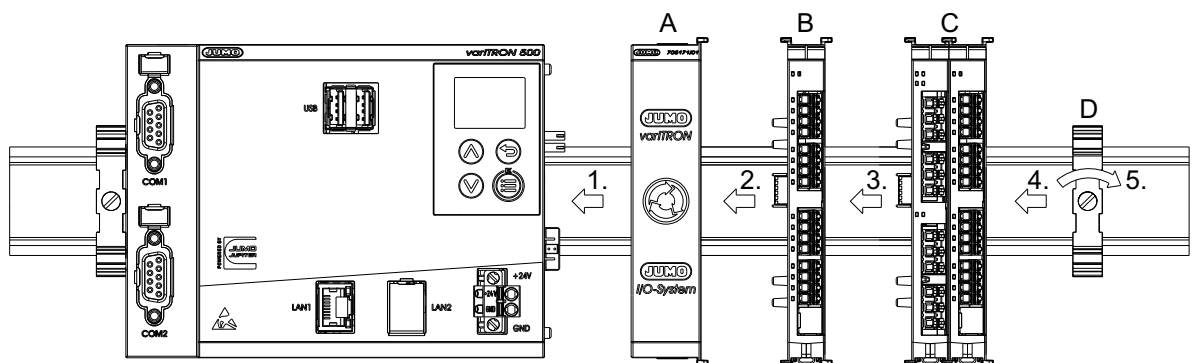

1. Move the system module (A) to the left against the central processing unit until the plug connections for the voltage supply and the system bus are connected.
2. Move module (B) to the left against the system module until the plug connections are connected.
3. Move additional modules (C) to the left against the previous module in the same manner.
4. After the final module, position the end bracket (D) on the DIN rail and move to the left against the module.
5. Fasten the end bracket (D) using a screwdriver. For this purpose, ensure that the end bracket is positioned firmly against the last module.



#### NOTE!

If necessary, use the optional connector bars (accessories) in order to increase the vibration and shock resistance of the module arrangement.

# 6 Electrical connection

---

## 6.1 Preparing the electrical connection

### NOTICE!

#### Damage to the modules

Do not plug or unplug the modules while they are live, as this could result in damage to the modules.

- ▶ Disconnect voltage supply.
- 



### NOTE!

The following notes apply to the entire I/O system (7051xx) and in some cases only applies to one module or another.

The respective connection diagram shows the context.

---

### Requirements for personnel

- Work on the modules must only be carried out to the extent described and, like the electrical connection, only by qualified personnel.
- Before plugging and unplugging connection lines, it must be ensured that the acting person is electrostatically discharged (e.g. by touching grounded metallic parts).

### Line, shielding, grounding

- When selecting the cable material, when installing, and when performing the electrical connection of the module, the regulations of DIN VDE 0100 "Erection of low voltage installations" or the respective national regulations (e.g. on the basis of IEC 60364) are to be observed.
- At maximum load, certain lines must be heat resistant up to at least 80 °C. The corresponding notes in the connection diagram of the affected modules must be observed.
- Route input, output, and supply lines separately and not parallel to one another.
- Only use shielded and twisted probe and interface cables. Do not route the lines close to current-carrying components or cables.
- For temperature probes, ground the shielding on one side in the control cabinet.
- Do not perform loopthroughs on the grounding cables, but route the cables individually to a shared grounding point in the control cabinet; in doing so, ensure that the cables are as short as possible. Ensure proper potential equalization.

### Electrical safety

- Isolate power supply units from the voltage supply on the primary side if there is a risk of touching parts with dangerous electrical voltage (e.g. 230 V) during active use.
- The fuse protection of the power supply units on the primary side should not exceed a value of 10 A (inert).
- With modules that have relay or solid state relay outputs, the load circuits can be operated with a dangerous electrical voltage (e.g. 230 V). Disconnect load circuits from the voltage supply during electrical connection.
- In order to prevent the destruction of the relay or solid state relay outputs in the event of an external short circuit in the load circuit, the load circuit should be fuse-protected to the maximum admissible output current.
- The modules are not suitable for installation in potentially explosive areas.
- In addition to a faulty installation, incorrectly set values on the module could also impair the correct function of the following process. Therefore, ensure that safety devices independent of the module (e.g. overpressure valves or temperature limiters/monitors) are available and that it is only possible for qualified personnel to define settings. Please observe the corresponding safety regulations in this context.

### 6.2 Connection elements

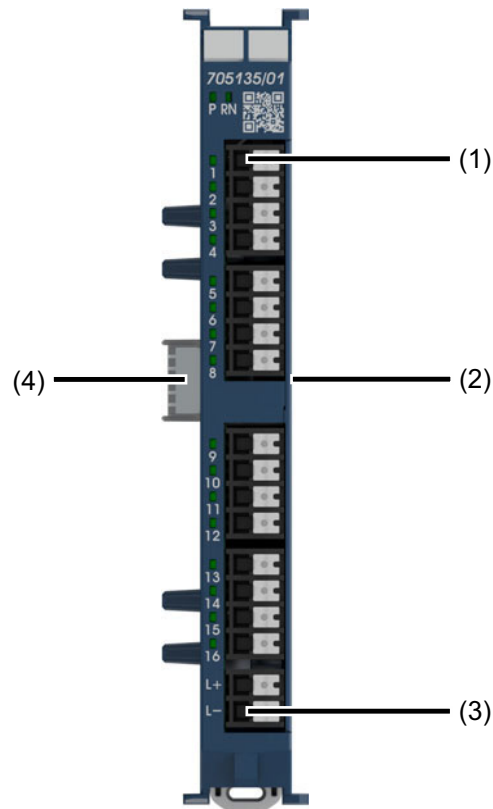

- 1 Connection terminal for digital input (here: input 1)
- 2 Plug connector (socket, side) for Out voltage supply and EtherCAT Out system bus
- 3 Connection terminal for reference potential (GND) of the digital inputs
- 4 Plug connector (side) for voltage supply and system bus

# 6 Electrical connection

## 6.3 Connection diagram

**NOTICE!**

At maximum load, the temperature may exceed 60 °C at the terminals.

This may damage the insulation of the line.

- ▶ The line must be heat resistant up to at least 80 °C.

**NOTICE!**

Signals to the several digital inputs must have the same ground reference.

Otherwise undefined signal levels may occur.

- ▶ Ground reference via GND terminal required!



**NOTE!**

Only copper lines must be connected to the terminals.

### 6.3.1 Digital inputs

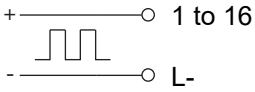
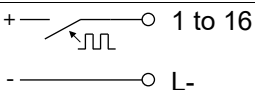
Signal type	Input	Terminals	Symbol and terminal designation
Digital signal DC 0/24 V Reference potential L- (GND) required.	1 to 16	1 and L- to 16 and L-	0/24 V 
Or:			
External voltage DC 24 V via potential-free contact Reference potential L- (GND) required.	1 to 16	1 and L- to 16 and L-	24 V 

The module is not started up separately, but rather together with the other I/O modules and the bus master, for example the JUMO variTRON 500 central processing unit (705002). The description of the start-up is therefore not the subject of this document.

The JUMO smartWARE Setup variTRON PC program and the JUMO Web Cockpit web application are required for startup. Further information can be found in the operating manual of the applicable central processing unit.

After the electrical connection of all modules and switch-on of the voltage supply, the LED displays of the module provide an initial message about the state of the module.

### **"P" LED (Power)**

The LED is permanently lit in green if the module is being supplied with voltage.

### **LED "RN" (Run)**

The LED (green) indicates the status of the module (EtherCAT Slave).

Description of the display modes and the displayed system states and errors: See operating manual for the applicable central processing unit.

### **LEDs of the digital inputs/outputs**

The LEDs indicate the logical state of the relevant digital input or output.

- LED is not lit = input/output is inactive (low level or relay contact in idle position).
- LED is lit (green) = input/output is active (high level or relay contact in operating position).

# 8 Configuration

The JUMO smartWARE Setup variTRON PC program is available to configure the module (referred to as setup program below). The module can also be configured using the JUMO variTRON Web Cockpit web application (referred to as Web Cockpit below).

The description of the setup program and the Web Cockpit is part of the operating manual for the respective JUMO variTRON central processing unit.

The description of the configuration of this module is part of this documentation.

The parameters described in the sections below can be found in the setup program or Web Cockpit under the following menu path: Configuration > System Bus > <Module designation>

Default settings are shown in bold in the parameter tables.



## NOTE!

In order for the "System Bus" menu to appear in the module, it must have been added previously with the "HW-Assistant System Bus" function to configure the system hardware. This function is only available in the setup program.

## 8.1 Device configuration

The basic settings of the module are specified in this menu.

Parameter	Value	Description
Module name	<Module name> (editable)	Designation of the module  The designation can be entered in several national languages.  Per default, the designation is only available in the "Standard" national language (is used if the designation is missing in the set device language).  The designation set per default contains the module type (example: 16x digital IN) and the unique module label (example: DIN16_3).

## 8.2 Process values

The digital outputs 1 to 16 are configured in this menu.

### Task

Parameter	Value	Description
Task for the input values	<b>1, 2</b>	The cycle time used to transfer the process data for the inputs from the central processing unit to the module via the system bus is set by selecting the task. <i>See Configuration &gt; System Bus &gt; Master.</i>  Task 1 should generally be used for digital inputs and outputs (short cycle time). Task 2 and task 3 are intended for transmitting analog process data (task 2 for input values, task 3 for output values).

### Inputs

Selection of the process data transmitted to the central processing unit via the system bus.

Parameter	Value	Description
TxPDO-Map Digital In 1-16		Designation of the file with the process data objects (PDO Assignment according to EtherCAT specification).

Parameter	Value	Description
Digital In 1 to Digital In 16		Process data object (digital input)
Active	No	Process data object is not active. – Cannot be selected, as the process data of all inputs or outputs is always transmitted with digital input modules and output modules.
	Yes	Process data object is active: The process data for the affected digital input is transmitted to the central processing unit.
Channel name	<Channel name> (editable)	Channel designation The designation can be entered in several national languages. No designation is specified per default.

### Behavior after power on

The inputs deliver the currently pending value.

### Behavior in the event of a failure of communication via the system bus

The central processing unit uses replacement values.

# 9 Shutdown

## 9.1 Dismounting



### DANGER!

The load circuits of modules that have relay or solid state relay outputs can be operated with a dangerous electrical voltage (e.g. 230 V).

There is a risk of electric shock.

- ▶ Before dismounting these modules, the load circuits must be disconnected from the voltage supply. This work must only be performed by qualified personnel.



### NOTE!

If the individual modules for increasing the vibration and shock resistance are connected to connector bars, these must be removed first (not shown here).

The following example shows the dismounting of an individual module from an arrangement of multiple modules.

### Releasing modules

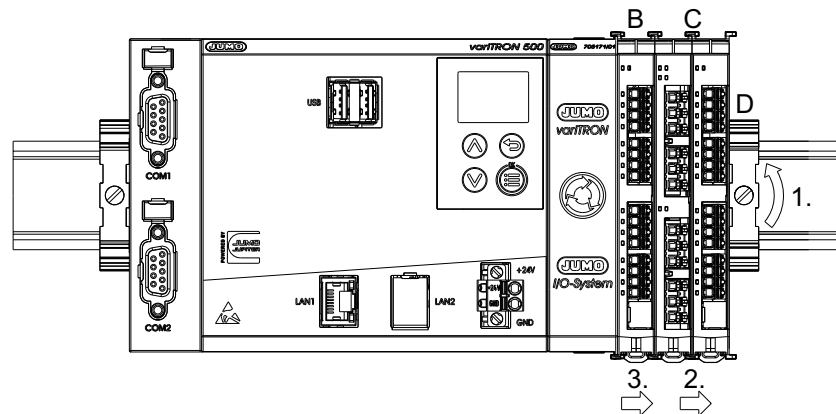

1. Fully release the end bracket (D) using a screwdriver, press upward from below, pivot toward the front, and remove from the DIN rail.

Note: The end bracket does not need to be removed from the DIN rail if there is sufficient space to the side to move it at least 20 mm to the right.

2. Move the modules (C) on the right next to the module (B) that is to be replaced a minimum of 20 mm to the right (B3).

*These modules are isolated from the voltage supply and the system bus.*

3. Module (B) should be moved to the right until the side contacts of the module are exposed.  
*The module is isolated from the voltage supply and the system bus. This is a prerequisite for dismounting the module.*

4. If necessary, remove wiring of the connections:

- a) Module with PCB terminal blocks: Loosen connection wires from terminals.
- b) Module with pluggable terminals: Remove wired connection terminals to the front.

## Removing module from DIN rail

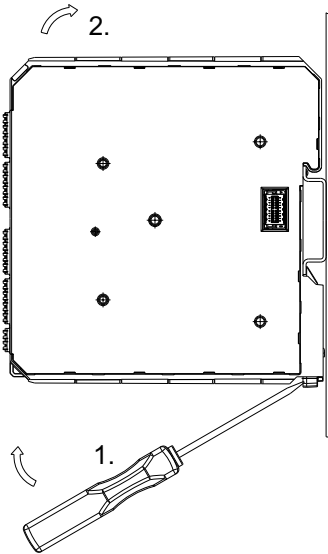

1. Insert a suitable screwdriver into the unlocking slot of the module and press upward.
2. Swing the module up and out of the DIN rail and remove.

## 9.2 Returns

Procedure:

1. The [supplementary sheet for product returns](#) must first be completed correctly and signed. Then enclose it with the shipping documents and attach it to the packaging, ideally on the outside.
2. Use the original packaging or a suitably secure container for sending the device.

## 9.3 Disposal



- Do not dispose of the device or replaced parts in the trash after use.
- Delete programs and data stored on the device.
- Remove batteries, if any, if this can be done without damaging the device.
- Dispose of the device and the packaging material in a responsible and environmentally friendly manner.
- Observe the country-specific laws and regulations for waste treatment and disposal.

In accordance with Directive 2012/19/EU on Waste from Electrical and Electronic Equipment, manufacturers are obliged to offer the option of returning waste equipment. Request the return from the manufacturer.

## 10 Accessories

---

<b>Designation</b>	<b>Part no.</b>
10 connector bars for increased vibration and shock resistance (2 bars are required for connecting 2 modules)	30065481
10 inscription labels for labeling the module	30065497





**JUMO GmbH & Co. KG**

Street address:  
Moritz-Juchheim-Straße 1  
36039 Fulda, Germany

Delivery address:  
Mackenrodtstraße 14  
36039 Fulda, Germany

Postal address:  
36035 Fulda, Germany

Phone: +49 661 6003-0  
Fax: +49 661 6003-607  
Email: [mail@jumo.net](mailto:mail@jumo.net)  
Internet: [www.jumo.net](http://www.jumo.net)

**JUMO UK LTD**

JUMO House  
Temple Bank, Riverway  
Harlow, Essex, CM20 2DY, UK

Phone: +44 1279 63 55 33  
Fax: +44 1279 62 50 29  
Email: [sales@jumo.co.uk](mailto:sales@jumo.co.uk)  
Internet: [www.jumo.co.uk](http://www.jumo.co.uk)

**JUMO Process Control, Inc.**

6724 Joy Road  
East Syracuse, NY 13057, USA

Phone: +1 315 437 5866  
Fax: +1 315 437 5860  
Email: [info.us@jumo.net](mailto:info.us@jumo.net)  
Internet: [www.jumousa.com](http://www.jumousa.com)

