

# Operating Instructions

Single channel controller for level detection for 4 ... 20 mA sensors

## VEGATOR 141



Document ID: 46838



# VEGA

# Contents

<b>1</b>	<b>About this document</b> .....	<b>4</b>
1.1	Function .....	4
1.2	Target group .....	4
1.3	Symbols used.....	4
<b>2</b>	<b>For your safety</b> .....	<b>5</b>
2.1	Authorised personnel .....	5
2.2	Intended use .....	5
2.3	Warning about incorrect use.....	5
2.4	General safety instructions .....	5
2.5	Installation and operation in the USA and Canada .....	6
<b>3</b>	<b>Product description</b> .....	<b>7</b>
3.1	Configuration .....	7
3.2	Principle of operation.....	7
3.3	Adjustment .....	8
3.4	Packaging, transport and storage.....	8
<b>4</b>	<b>Mounting</b> .....	<b>9</b>
4.1	General instructions .....	9
<b>5</b>	<b>Connecting to power supply</b> .....	<b>10</b>
5.1	Preparing the connection .....	10
5.2	Input mode active/passive.....	10
5.3	Connection procedure.....	11
5.4	Wiring plan .....	12
5.5	Connection example, mixed operation active/passive .....	12
<b>6</b>	<b>Setup</b> .....	<b>14</b>
6.1	Adjustment system .....	14
6.2	Adjustment elements.....	14
6.3	Switching point adjustment with 4 ... 20 mA sensor (continuous) .....	16
6.4	Switching point adjustment with capacitive sensor (limit level) .....	17
6.5	Proof test.....	18
6.6	Function diagram.....	19
<b>7</b>	<b>Diagnostics and servicing</b> .....	<b>21</b>
7.1	Maintenance .....	21
7.2	Rectify faults.....	21
7.3	Diagnosis, fault messages .....	21
7.4	How to proceed if a repair is necessary.....	22
<b>8</b>	<b>Dismount</b> .....	<b>24</b>
8.1	Dismounting steps.....	24
8.2	Disposal .....	24
<b>9</b>	<b>Certificates and approvals</b> .....	<b>25</b>
9.1	Approvals for Ex areas .....	25
9.2	Conformity.....	25
9.3	SIL conformity (optional) .....	25
9.4	Environment management system .....	25
<b>10</b>	<b>Supplement</b> .....	<b>26</b>
10.1	Technical data .....	26

10.2	Dimensions .....	28
10.3	Industrial property rights.....	29
10.4	Trademark .....	29

# 1 About this document

## 1.1 Function

This instruction provides all the information you need for mounting, connection and setup as well as important instructions for maintenance, fault rectification, safety and the exchange of parts. Please read this information before putting the instrument into operation and keep this manual accessible in the immediate vicinity of the device.

## 1.2 Target group

This instruction manual is directed to trained personnel. The contents of this manual must be made available to the qualified personnel and implemented.

## 1.3 Symbols used



### Document ID

This symbol on the front page of this instruction refers to the Document ID. By entering the Document ID on [www.vega.com](http://www.vega.com) you will reach the document download.



**Information, note, tip:** This symbol indicates helpful additional information and tips for successful work.



**Note:** This symbol indicates notes to prevent failures, malfunctions, damage to devices or plants.



**Caution:** Non-observance of the information marked with this symbol may result in personal injury.



**Warning:** Non-observance of the information marked with this symbol may result in serious or fatal personal injury.



**Danger:** Non-observance of the information marked with this symbol results in serious or fatal personal injury.



### Ex applications

This symbol indicates special instructions for Ex applications.



### List

The dot set in front indicates a list with no implied sequence.



### Sequence of actions

Numbers set in front indicate successive steps in a procedure.



### Disposal

This symbol indicates special instructions for disposal.

## 2 For your safety

### 2.1 Authorised personnel

All operations described in this documentation must be carried out only by trained and authorized personnel.

During work on and with the device, the required personal protective equipment must always be worn.

### 2.2 Intended use

VEGATOR 141 is a universal controller for connection of level switches.

You can find detailed information about the area of application in chapter "*Product description*".

Operational reliability is ensured only if the instrument is properly used according to the specifications in the operating instructions manual as well as possible supplementary instructions.

### 2.3 Warning about incorrect use

Inappropriate or incorrect use of this product can give rise to application-specific hazards, e.g. vessel overfill through incorrect mounting or adjustment. Damage to property and persons or environmental contamination can result. Also, the protective characteristics of the instrument can be impaired.

### 2.4 General safety instructions

This is a state-of-the-art instrument complying with all prevailing regulations and directives. The instrument must only be operated in a technically flawless and reliable condition. The operating company is responsible for the trouble-free operation of the instrument. When measuring aggressive or corrosive media that can cause a dangerous situation if the instrument malfunctions, the operating company has to implement suitable measures to make sure the instrument is functioning properly.

During the entire duration of use, the operating company is obliged to determine the compliance of the necessary occupational safety measures with the current valid rules and regulations and also take note of new regulations.

The safety instructions in this operating instructions manual, the national installation standards as well as the valid safety regulations and accident prevention rules must be observed.

For safety and warranty reasons, any invasive work on the device beyond that described in the operating instructions manual may be carried out only by personnel authorised by us. Arbitrary conversions or modifications are explicitly forbidden. For safety reasons, only the accessory specified by us must be used.

To avoid any danger, the safety approval markings and safety tips on the device must also be observed.

## **2.5 Installation and operation in the USA and Canada**

This information is only valid for USA and Canada. Hence the following text is only available in the English language.

Installations in the US shall comply with the relevant requirements of the National Electrical Code (NEC - NFPA 70) (USA).

Installations in Canada shall comply with the relevant requirements of the Canadian Electrical Code (CEC Part I) (Canada).

## 3 Product description

### 3.1 Configuration

#### Scope of delivery

The scope of delivery encompasses:

- Controller VEGATOR 141

The further scope of delivery encompasses:

- Documentation
  - Ex-specific "*Safety instructions*" (with Ex versions)
  - Safety Manual (with SIL version)
  - If necessary, further certificates



#### Information:

Optional instrument features are also described in this instructions. The respective scope of delivery results from the order specification.

#### Type label

The type label contains the most important data for identification and use of the instrument:

- Instrument type
- Information about approvals
- Configuration information
- Technical data
- Serial number of the instrument
- QR code for device identification
- Manufacturer information

#### Documents and software

To find order data, documents or software related to your device, you have the following options:

- Move to "[www.vega.com](http://www.vega.com)" and enter in the search field the serial number of your instrument.
- Scan the QR code on the type label.
- Open the VEGA Tools app and enter the serial number under "*Documentation*".

### 3.2 Principle of operation

#### Application area

The VEGATOR 141 is a single-channel controller for level detection with 4 ... 20 mA sensors. Simple monitoring and control functions can be realised via the integrated relay. Typical applications are monitoring functions such as overflow and dry run protection. An optional fail safe relay is also available.

#### Functional principle

The VEGATOR 141 controller powers the connected sensors and simultaneously processes their measuring signals. Each input is continuously monitored for line break or short-circuit. In addition, fault signals delivered by the sensor are processed.

The current of a connected 4 ... 20 mA sensor is measured and evaluated. The switching point of the relay can be adjusted to any individual current by using the potentiometer. The output relay switches when this current is reached (in dependence on the set mode).

### 3.3 Adjustment

All adjustment elements are located under a hinged front cover. The operating mode and the switching delay can be set via a DIL switch block. The switching point can be adjusted via a potentiometer.

### 3.4 Packaging, transport and storage

#### Packaging

Your instrument was protected by packaging during transport. Its capacity to handle normal loads during transport is assured by a test based on ISO 4180.

The packaging consists of environment-friendly, recyclable cardboard. For special versions, PE foam or PE foil is also used. Dispose of the packaging material via specialised recycling companies.

#### Transport

Transport must be carried out in due consideration of the notes on the transport packaging. Nonobservance of these instructions can cause damage to the device.

#### Transport inspection

The delivery must be checked for completeness and possible transit damage immediately at receipt. Ascertained transit damage or concealed defects must be appropriately dealt with.

#### Storage

Up to the time of installation, the packages must be left closed and stored according to the orientation and storage markings on the outside.

Unless otherwise indicated, the packages must be stored only under the following conditions:

- Not in the open
  - Dry and dust free
  - Not exposed to corrosive media
  - Protected against solar radiation
  - Avoiding mechanical shock and vibration
- Storage and transport temperature see chapter "*Technical data - Ambient conditions*"
  - Relative moisture 20 ... 85 %

#### Storage and transport temperature

## 4 Mounting

### Mounting options

### 4.1 General instructions

VEGATOR 141 is designed for carrier rail mounting (top hat rail 35 x 7.5 according to DIN EN 50022/60715). Due to its protection rating of IP20, the instrument is suitable for mounting in switching cabinets. It can be mounted horizontally and vertically.

**Note:**

When several instruments are mounted together without space in between, the ambient temperature at the installation location of the instrument must not exceed 60 °C. Around the ventilation slots there must be a distance of at least 2 cm to the next component.



VEGATOR 141 in Ex version is a corresponding, intrinsically safe instrument and must not be installed in hazardous areas. A safe operation is only ensured if the operating instructions and EU type approval certificate are observed. VEGATOR 141 must not be opened.

A distance of 50 mm to the intrinsically safe terminals must be ensured when mounting.

### Ambient conditions

The instrument is suitable for standard and extended ambient conditions acc. to DIN/EN/BS EN/IEC/ANSI/ISA/UL/CSA 61010-1.

Make sure that the environmental and ambient conditions specified in chapter "*Technical data*" are maintained.

## 5 Connecting to power supply

### 5.1 Preparing the connection

#### Safety instructions

Always keep in mind the following safety instructions:



#### Warning:

Connect only in the complete absence of line voltage.

- Connect only in the complete absence of line voltage
- If overvoltage surges are expected, overvoltage arresters should be installed



#### Note:

Install a disconnecting device for the instrument which is easy to access. The disconnecting device must be marked for the instrument (IEC/EN 61010).

#### Safety instructions for Ex applications



In hazardous areas you must take note of the respective regulations, conformity and type approval certificates of the sensors and power supply units.

#### Voltage supply

The data for power supply are specified in chapter "*Technical data*".

#### Connection cable

The voltage supply of VEGATOR 141 is connected with standard cable according to the national installation standards.

The sensors are connected with standard two-wire cable without shielding. If electromagnetic interference is expected which is above the test values of EN 61326 for industrial areas, shielded cable should be used.

Make sure that the cable used has the required temperature resistance and fire safety for max. occurring ambient temperature

#### Cable screening and grounding

Connect the cable shielding on both ends to ground potential. In the sensor, the shielding must be connected directly to the internal ground terminal. The ground terminal on the outside of the sensor housing must be connected to the potential equalisation (low impedance).

If potential equalisation currents are expected, the connection on the processing side must be made via a ceramic capacitor (e. g. 1 nF, 1500 V). The low-frequency potential equalisation currents are thus suppressed, but the protective effect against high frequency interference signals remains.

#### Connection cable for Ex applications



Take note of the corresponding installation regulations for Ex applications. In particular, make sure that no potential equalisation currents flow over the cable screen. In case of grounding on both sides this can be achieved by the use of a capacitor or a separate potential equalisation described above.

### 5.2 Input mode active/passive

Through the selection of the terminals, you can choose between active and passive operation of the measuring data input.

- In active mode, VEGATOR 141 provides the power for the connected sensors. Power and measurement data are transmitted over the same two-wire cable. This mode is provided for connection of measuring transducers without separate power supply (sensors in two-wire version).
- In passive mode, the sensors are not powered, only the measured value is transmitted. This input is provided for connection of transducers with their own separate voltage supply (sensors in four-wire version). Furthermore the VEGATOR 141 can be looped like a standard ammeter into the existing circuit. It is thus possible to control multiple controllers with one sensor to detect different limit levels.

**Note:**

With a VEGATOR 141 in Ex version, the passive input is not available for reasons of approval.

### 5.3 Connection procedure

The pluggable terminals can be removed as needed to allow more convenient connection. To make the electrical connection, proceed as follows:

1. Mount the instrument as described in the previous chapter
2. Connect sensor cable to terminal 1/2, and where applicable, connect the shielding
3. Connect switched-off power supply to terminal 16/17
4. Connect terminal 10/11/12 for relay output
5. For option with fail safe relay: Connect terminal 13/14/15 for fail safe relay

The electrical connection is finished.

## 5.4 Wiring plan

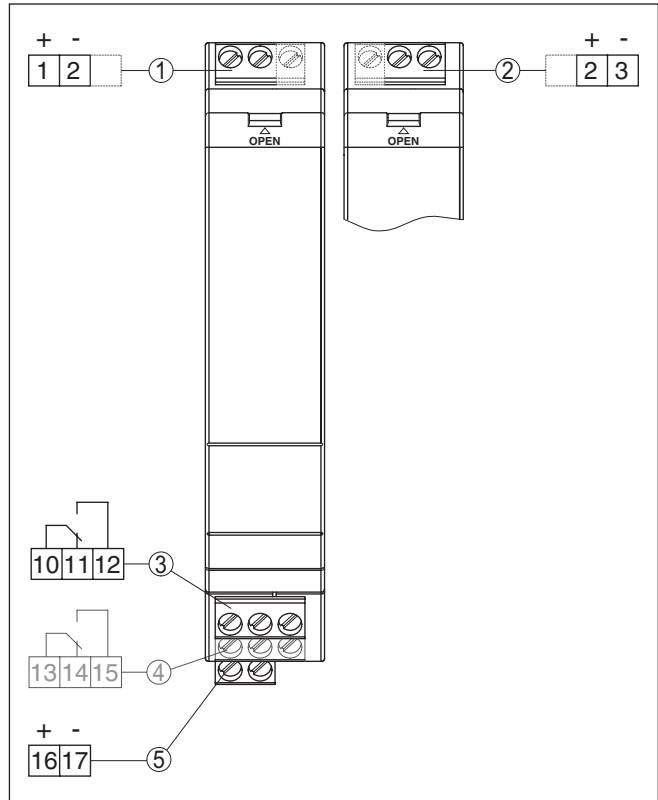

Fig. 1: Wiring plan VEGATOR 141

- 1 Sensor circuit (4 ... 20 mA), active input
- 2 Sensor circuit (4 ... 20 mA), passive input<sup>1)</sup>
- 3 Relay output
- 4 Fail safe relay (optional)
- 5 Voltage supply



### Information:

The connection terminals can be detached towards the front, if necessary. This can be useful when working in tight spaces or when exchanging an instrument.

## 5.5 Connection example, mixed operation active/passive

With this wiring, one sensor can control several controllers and thus detect different limit levels. This wiring is not possible for Ex applications, as the passive input is not available for Ex devices.

<sup>1)</sup> Not available with Ex version.



**Note:**

The internal resistance of the passive input must be viewed as a 100 Ω load when connecting multiple instruments.

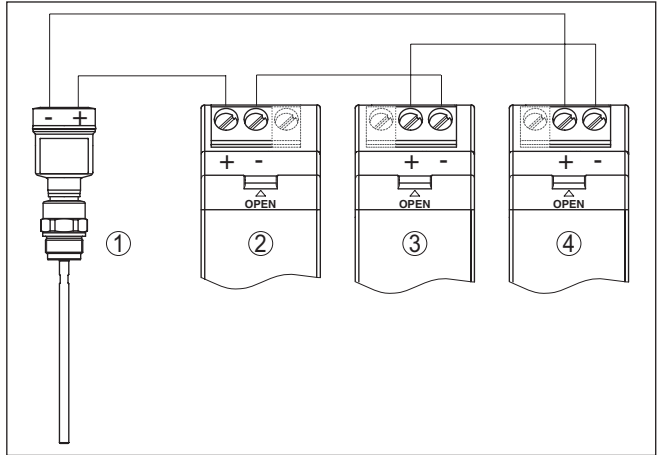

Fig. 2: Connection example, mixed operation active/passive

- 1 Sensor
- 2 VEGATOR 141, active input
- 3 VEGATOR 141, passive input
- 4 VEGATOR 141, passive input

## 6 Setup

### 6.1 Adjustment system

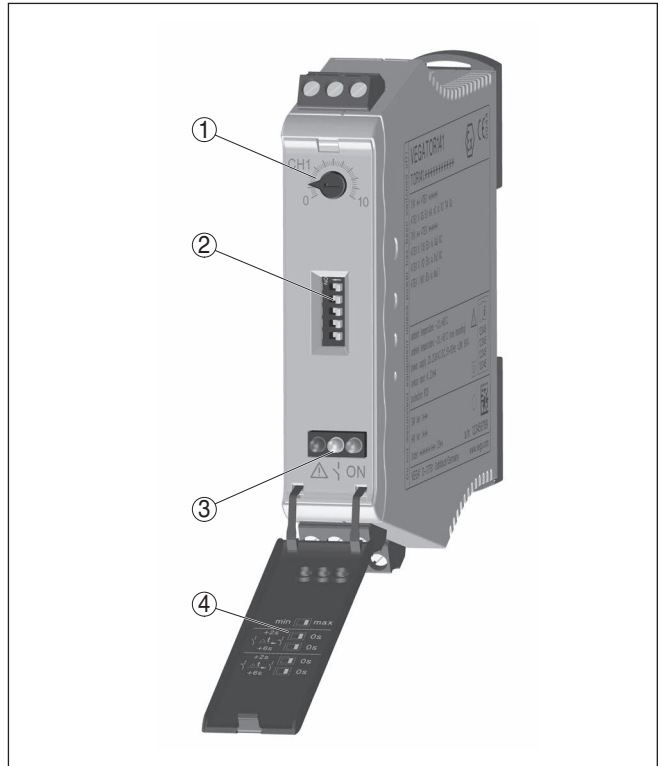

Fig. 3: Display and adjustment elements

- 1 Potentiometer for switching point adjustment
- 2 DIL switch block
- 3 Signal lamps (LEDs)
- 4 Hinged front cover

### 6.2 Adjustment elements

#### Control lamps

Control lamps (LED) in the front plate indicate operation, switching status and fault signal.

- Green
  - Operating control lamp
  - Mains voltage on, instrument is operating
- Red
  - Fault indicator
  - Fault on the sensor circuit due to sensor failure or line break
  - The relay deenergises in case of failure

- Yellow
  - Relay control lamp
  - Lights with activated (current-carrying) relay status

**Front cover**

The adjustment elements are located under a hinged front cover. To open it, use a small screwdriver in conjunction with the slot on the upper side of the front cover. To close it, push the cover at bottom and top firmly onto the front cover until you hear the two retaining clips snap in.

**DIL switch block**

The DIL switch block is located behind the front cover. The individual switches are assigned as follows:

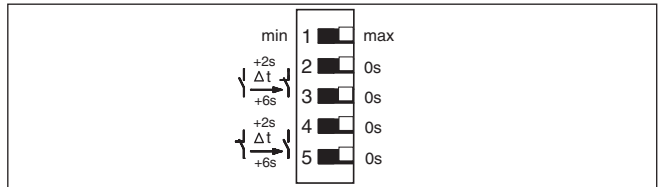

Fig. 4: DIL switch VEGATOR 141

- 1 Mode (min./max. adjustment)
- 2 Switch-on delay 2 seconds
- 3 Switch-on delay 6 seconds
- 4 Switch-off delay 2 seconds
- 5 Switch-off delay 6 seconds

**Mode (min./max. adjustment)**

The requested operating mode is set with the min./max. switch (min. detection i.e. dry run protection or max. detection i.e. overflow protection)

- **Dry run protection:** Relay is switched off when the level falls below the min. level (safe currentless state), relay is switched on again when the min. level is exceeded (switch-on point > switch-off point)
- **Overflow protection:** Relay is switched off when the max. level is exceeded (safe currentless state), relay is switched on again when the level falls below the max. level (switch-on point < switch-off point)



**Note:**

Selection of the mode on the controller only functions correctly if the 4 ... 20 mA characteristics are set in the sensor.

**Switch-on/Switch-off delay**

With these switches you can delay the changeover of the relays by the set time. This can be useful, e.g. with fluctuating product surfaces, for preventing unwanted switching commands. The switch-on/off delays can be set independently of each other. If both switches, e.g. of the switch-on delay, are activated, the times sum up. Delays of 2, 6 or 8 seconds can thus be adjusted.

**Information:**

Keep in mind that the switching delay of the sensor and controller accumulate.

**Potentiometer for switching point adjustment**

The relay switching point is adjusted via a potentiometer. You can find a detailed description depending on the mode and the installed sensors in the following chapters.

**6.3 Switching point adjustment with 4 ... 20 mA sensor (continuous)**

When using a continuously measuring 4 ... 20 mA sensor, the switching point can be set to any position between 0 ... 100 %. Depending on the mode, you now adjust the switching point as described in the following.

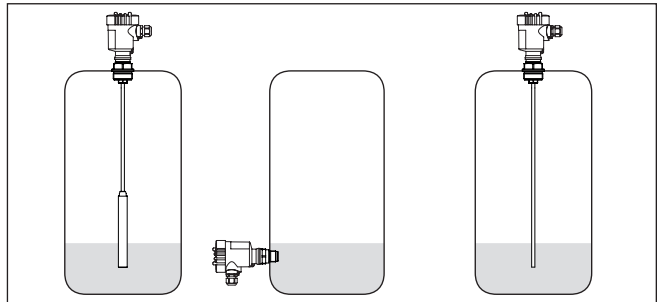

Fig. 5: Application examples with 4 ... 20 mA sensor (pressure transmitter or capacitive rod probe)

**Overflow protection (max. operation)**

1. Make sure that switch 1 on the DIL switch block is set to "**max.**". The switches for the switch-on and switch-off delay should be set to "0 s".
2. Set the potentiometer to the right end position, the yellow LED display lights
3. Fill the vessel up to the requested max. level
4. Turn the potentiometer slowly anticlockwise until the yellow LED display extinguishes, the controller is now ready for operation

**Dry run protection (min. operation)**

1. Make sure that switch 1 on the DIL switch block is set to "**min.**". The switches for the switch-on and switch-off delay should be set to "0 s".
2. Set the potentiometer to the left end position, the yellow LED display lights
3. Empty the vessel down to the requested min. level
4. Turn the potentiometer slowly clockwise until the yellow LED display extinguishes, the controller is now ready for operation

## 6.4 Switching point adjustment with capacitive sensor (limit level)

When using a capacitive point level sensors, the switching point is mainly determined through the installation position. Via the potentiometer, the switching point is adapted to the measured medium. Please also observe the operating instructions of the sensor, especially the sensitivity adjustment. Depending on the mode you now adjust the switching point as described in the following.



### Note:

In order to set a reliable, precise switching point, the vessel must be filled (sensor uncovered and covered). If this is not possible, you can carry out the adjustment with an empty vessel up to step 4 and "search" for the (approximate) switching point. Check or adjust the switching point later on during operation when the sensor is covered.

### Overflow protection (max. operation)

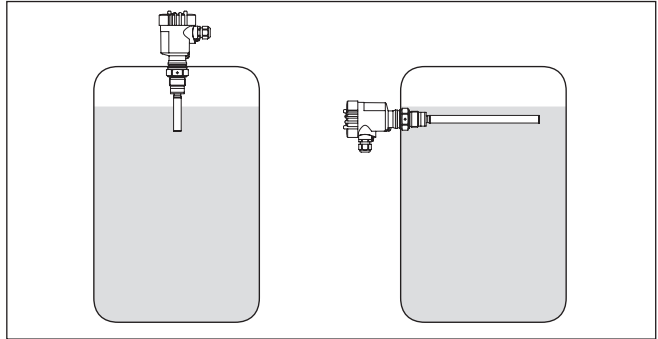

Fig. 6: Application examples of overflow protection with a capacitive point level sensor

1. Make sure that switch 1 on the DIL switch block is set to "max.". The switches for the switch-on and switch-off delay should be set to "0 s".
2. The vessel should be empty i.e. the sensor must not be covered
3. Set the potentiometer to the left end position, the yellow LED display extinguishes
4. Turn the potentiometer slowly clockwise until the yellow LED display lights, note the position of the potentiometer
5. Continue filling the vessel until the sensor is completely covered, the yellow LED display extinguishes
6. Turn the potentiometer slowly clockwise until the yellow LED display lights again, note also this position of the potentiometer
7. Calculate the average value from these two values and set it on the potentiometer, the controller is then ready for operation

### Dry run protection (min. operation)

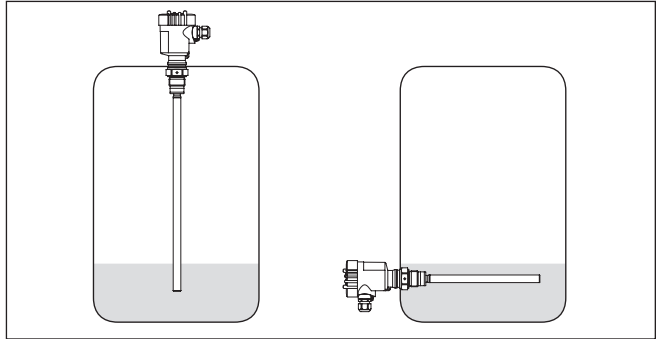

Fig. 7: Application examples of dry run protection with a capacitive point level sensor

1. Make sure that switch 1 on the DIL switch block is set to "min.". The switches for the switch-on and switch-off delay should be set to "0 s".
2. The vessel should be empty i.e. the sensor must not be covered
3. Set the potentiometer to the left end position, the yellow LED display lights
4. Turn the potentiometer slowly clockwise until the yellow LED display extinguishes, note the position of the potentiometer
5. Continue filling the vessel until the sensor is completely covered, the yellow LED display lights
6. Turn the potentiometer slowly clockwise until the yellow LED display extinguishes again, note also this position of the potentiometer
7. Calculate the average value from these two values and set it on the potentiometer, the controller is then ready for operation

## 6.5 Proof test



### Note:

When handling environmentally hazardous substances, danger to the environment and to persons must be avoided. After setup, the proper functioning of the instrument must be ensured by means of the proof test described below.

- **Detection of line break:** Disconnect the sensor cable for the duration of this test
  - The red fault LED must light up
  - The relay must be deenergized
- **Detection of short-circuit:** Short-circuit the sensor cable for the duration of this test
  - The red fault LED must light up
  - The relay must be deenergized

- **Switching point monitoring (overflow protection):** Fill the vessel up to the set switching point
  - When the switching point is reached, the respective relay must deenergize
- **Switching point monitoring (dry run protection):** Empty the vessel down to the set switching point
  - When the switching point is reached, the respective relay must deenergize

### 6.6 Function diagram

The following diagram provides an overview of the switching statuses depending on the set mode and the level.



**Note:**

Selection of the mode on the controller only functions correctly if the 4 ... 20 mA characteristics are set in the sensor.

**Single-point control/limit level**

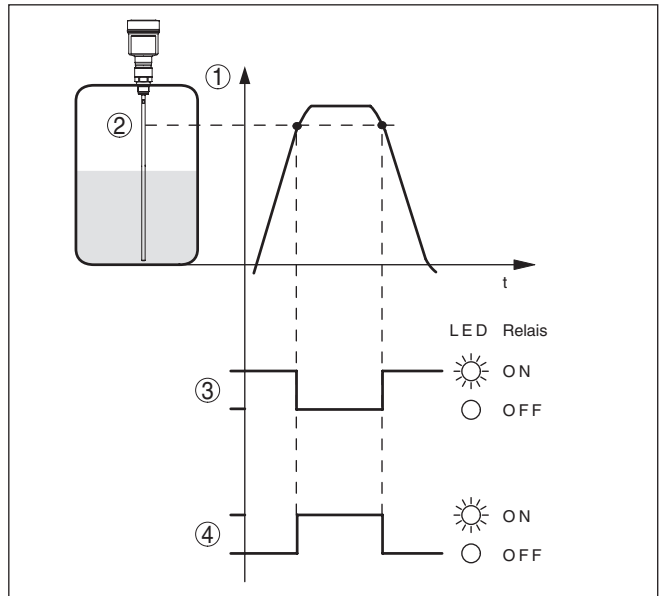

Fig. 8: Function diagram, single-point control

- 1 Filling height
- 2 Switching point
- 3 Mode overflow protection
- 4 Mode dry run protection

In the instrument version with fail-safe relay, the relay is switched on in normal operating state (without fault signal). In case of fault, the relay is switched off (safe currentless state).

The fail-safe relay switches to the safe state under the following conditions:

- Sensor signals failure (sensor current  $< 3.6 \text{ mA}$  or  $> 21 \text{ mA}$ )
- Line break between sensor and VEGATOR 141 (sensor current  $< 3.6 \text{ mA}$ )
- Shortcircuit on the sensor input or defective sensor (sensor current  $> 21 \text{ mA}$ )
- Internal device diagnosis recognises an error
- Voltage supply outside the specification

## 7 Diagnostics and servicing

### 7.1 Maintenance

#### Maintenance

If the device is used properly, no special maintenance is required in normal operation.

#### Cleaning

The cleaning helps that the type label and markings on the instrument are visible.

Take note of the following:

- Use only cleaning agents which do not corrode the housings, type label and seals
- Use only cleaning methods corresponding to the housing protection rating

### 7.2 Rectify faults

#### Reaction when malfunction occurs

The operator of the system is responsible for taking suitable measures to rectify faults.

#### Causes of malfunction

The device offers maximum reliability. Nevertheless, faults can occur during operation. These may be caused by the following, e.g.:

- Measured value from sensor not correct
- Voltage supply
- Interference in the cables

#### Fault rectification

The first measure to be taken is to check the input and output signals. The procedure is described as follows. In many cases the causes can be determined this way and faults can be easily rectified.

#### Reaction after fault rectification

Depending on the reason for the fault and the measures taken, the steps described in chapter "Setup" must be carried out again or must be checked for plausibility and completeness.

#### 24 hour service hotline

Should these measures not be successful, please call in urgent cases the VEGA service hotline under the phone no. **+49 1805 858550**.

The hotline is also available outside normal working hours, seven days a week around the clock.

Since we offer this service worldwide, the support is provided in English. The service itself is free of charge, the only costs involved are the normal call charges.

### 7.3 Diagnosis, fault messages

#### Fault signal

The controller and the connected sensors are permanently monitored during operation. If irregularities occur, a fault signal is triggered. In the event of a failure, the fault indication lights up and the relays are de-energized (safe state).

## Red fault LED lights up

Cause	Rectification
Sensor not connected correctly	<ul style="list-style-type: none"> <li>● In Ex systems, make sure that the Ex protection is not influenced by the measuring instruments used</li> <li>● Measure the current and voltage on the connection cable to the sensor</li> <li>● Faults in the sensor causing a current change to below 3.6 mA or over 21 mA lead to a fault signal in the controllers</li> <li>● The terminal voltage at the sensor must be within the specified range. You can find this voltage range in the operating instructions of the connected sensor</li> </ul>
Sensor current < 3.6 mA	<ul style="list-style-type: none"> <li>● Check controller</li> <li>● Check the terminal voltage on the controller; if it is &lt; 17 V, the controller is defective -&gt; exchange controller or return it for repair</li> <li>● If the terminal voltage is &gt; 17 V, disconnect the sensor cable at the controller and replace it with a 1 kΩ resistor. If the fault signal does not disappear, the controller is defective -&gt; exchange controller or return it for repair</li> <li>● Check sensor or sensor cable</li> <li>● Reconnect the sensor cable to the controller, disconnect the sensor and replace it with a 1 kΩ resistor. If the fault signal does not disappear, then the sensor cable is broken -&gt; replace the sensor cable</li> <li>● If there is no longer a fault signal on the line, the sensor is defective -&gt; exchange sensor or return it for repair</li> </ul>
Sensor current > 21 mA	<ul style="list-style-type: none"> <li>● Check controller</li> <li>● Disconnect sensor cable and replace it with a 1 kΩ resistor. If the fault signal does not disappear, the controller is defective -&gt; exchange controller or return it for repair</li> <li>● Check sensor or sensor cable</li> <li>● Reconnect the sensor cable to the controller, disconnect the sensor and replace it with a 1 kΩ resistor. If the fault signal does not disappear, then the sensor cable is short-circuited -&gt; eliminate the short-circuit or replace the sensor cable</li> <li>● If there is no longer a fault signal on the line, the sensor is defective -&gt; exchange sensor or return it for repair</li> </ul>

## 7.4 How to proceed if a repair is necessary

On our homepage you will find detailed information on how to proceed in the event of a repair.

So that we can carry out the repair quickly and without queries, generate a instrument return form there with the data of your device.

The following is required:

- The serial number of the instrument
- A short description of the fault

- Details of the medium, if applicable

Print the generated instrument return form.

Clean the instrument and pack it damage-proof.

Send the printed instrument return form and possibly a safety data sheet together with the device.

You will find the address for the return on the generated instrument return form.

## 8 Dismount

### 8.1 Dismounting steps

Take note of chapters "*Mounting*" and "*Connecting to voltage supply*" and carry out the listed steps in reverse order.

### 8.2 Disposal



Pass the instrument on to a specialised recycling company and do not use the municipal collecting points.

Remove any batteries in advance, if they can be removed from the device, and dispose of them separately.

If personal data is stored on the old device to be disposed of, delete it before disposal.

If you have no way to dispose of the old instrument properly, please contact us concerning return and disposal.

## 9 Certificates and approvals

### 9.1 Approvals for Ex areas

Approved versions for use in hazardous areas are available or in preparation for the device or the device series.

You can find the relevant documents on our homepage.

### 9.2 Conformity

The device complies with the legal requirements of the applicable country-specific directives or technical regulations. We confirm conformity with the corresponding labelling.

The corresponding conformity declarations can be found on our homepage.

### 9.3 SIL conformity (optional)

Instruments with SIL option fulfill the requirements of functional safety according to IEC 61508. You can find further information in the supplied Safety Manual.

### 9.4 Environment management system

Protection of the environment is one of our most important duties. That is why we have introduced an environment management system with the goal of continuously improving company environmental protection. The environment management system is certified according to DIN EN ISO 14001.

Help us to meet these requirements and observe the environmental instructions in the chapters "*Packaging, transport and storage*", "*Disposal*" of this instructions manual.

## 10 Supplement

### 10.1 Technical data

#### Note for approved instruments

The technical data in the respective safety instructions are valid for approved instruments (e.g. with Ex approval). In some cases, these data can differ from the data listed herein.

All approval documents can be downloaded from our homepage.

#### General data

Series	Module unit for mounting on carrier rails 35 x 7.5 acc. to EN 50022/60715
Weight	125 g (4.02 oz)
Housing material	Polycarbonate PC-FR
Connection terminals	
– Type of terminal	Screw terminal
– Wire cross-section	0.25 mm <sup>2</sup> (AWG 23) ... 2.5 mm <sup>2</sup> (AWG 12)

#### Voltage supply

Operating voltage	
– Nominal voltage AC	24 ... 230 V (-15 %, +10 %), 50/60 Hz
– Nominal voltage DC	24 ... 65 V (-15 %, +10 %)
Max. power consumption	2 W (8 VA)

#### Sensor input

Quantity	1 x 4 ... 20 mA
Type of input (selectable)	
– Active input	Sensor supply through VEGATOR 141
– Passive input <sup>2)</sup>	Sensor has an own voltage supply
Measured value transmission	
– 4 ... 20 mA	analogue for 4 ... 20 mA sensors
Switching threshold	
– Adjustable in the range	4 ... 20 mA
– Hysteresis	100 µA
Current limitation	23 mA (permanently short-circuit proof)
Terminal voltage (idle state)	18.2 V DC, ± 5 %
Terminal voltage mode active	17.2 ... 14 V at 4 ... 20 mA
Internal resistance	
– Active input	200 Ω, ± 1 %
– Passive input	100 Ω, ± 1 %
Detection line break	≤ 3.6 mA
Detection shortcircuit	≥ 21 mA

<sup>2)</sup> Not available with Ex version.

---

**Relay output**

---

Quantity	1 x operating relay, 1 x fail safe relay (optional)
Contact	Floating change-over contact (SPDT)
Contact material	AgSnO <sub>2</sub> , hard gold-plated
Switching voltage	min. 10 mV DC, max. 253 V AC/50 V DC
Switching current	min. 10 µA DC, max. 3 A AC, 1 A DC
Breaking capacity <sup>3)</sup>	min. 50 mW, max. 500 VA, max. 54 W DC
Phase angle cos φ with AC	≥ 0.7
Switch-on/Switch-off delay	
– Basic delay	150 ms, ± 10 %
– Adjustable delay	2/6/8 s, ± 20 %

---

**Indicators**

---

LED displays	
– Status, operating voltage	1 x LED green
– Status fault signal	1 x LED red
– Status, operating relay	1 x LED yellow

---

**Adjustment**

---

5 x DIL switch	Adjustment mode, switching delay
1 x potentiometer	for switching point adjustment

---

**Ambient conditions**

---

Ambient temperature at the installation site of the instrument	-20 ... +60 °C (-4 ... +140 °F)
Storage and transport temperature	-40 ... +70 °C (-40 ... +158 °F)
Relative humidity	< 96 %

---

**Mechanical environmental conditions**

---

Vibrations (oscillations)	Class 4M4 acc. to IEC 60721-3-4 (1 g, 4 ... 200 Hz)
Impacts (mechanical shock)	Class 6M4 acc. to IEC 60721-3-6 (10 g/11 ms, 30 g/6 ms, 50 g/2.3 ms)

---

**Electrical protective measures**

---

Protection rating	IP 20
Overvoltage category (IEC 61010-1)	
– up to 2000 m (6562 ft) above sea level	II
– up to 5000 m (16404 ft) above sea level	II - Only with connected overvoltage protection level

<sup>3)</sup> If inductive loads or stronger currents are switched through, the gold plating on the relay contact surface will be permanently damaged. The contact is then no longer suitable for switching low-level signal circuits.

– up to 5000 m (16404 ft) above sea level	I
Protection class	II
Pollution degree	2

### Measures for electrical separation

Reliable separation according to VDE 0106 part 1 between all circuits

– Reference voltage	253 V
– Insulation resistance	5.1 kV

## 10.2 Dimensions

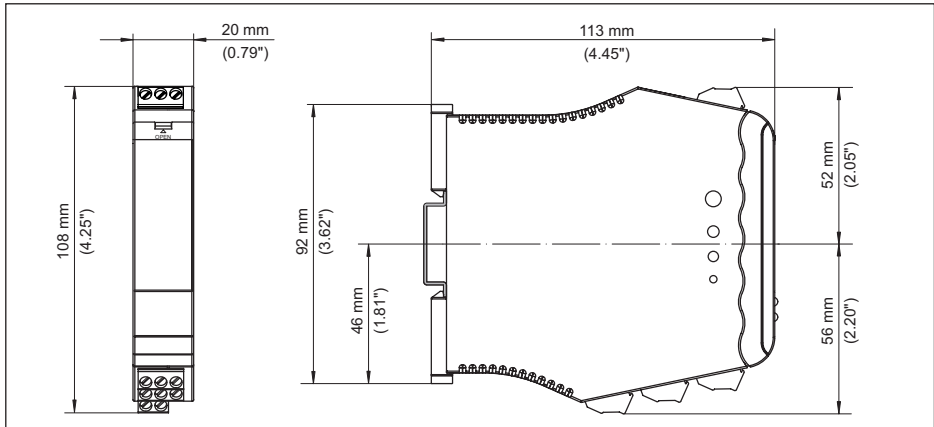

Fig. 9: Dimensions VEGATOR 141

### 10.3 Industrial property rights

VEGA product lines are global protected by industrial property rights. Further information see [www.vega.com](http://www.vega.com).

VEGA Produktfamilien sind weltweit geschützt durch gewerbliche Schutzrechte.

Nähere Informationen unter [www.vega.com](http://www.vega.com).

Les lignes de produits VEGA sont globalement protégées par des droits de propriété intellectuelle. Pour plus d'informations, on pourra se référer au site [www.vega.com](http://www.vega.com).

VEGA lineas de productos están protegidas por los derechos en el campo de la propiedad industrial. Para mayor información revise la pagina web [www.vega.com](http://www.vega.com).

Линии продукции фирмы ВЕГА защищаются по всему миру правами на интеллектуальную собственность. Дальнейшую информацию смотрите на сайте [www.vega.com](http://www.vega.com).

VEGA系列产品在全球享有知识产权保护。

进一步信息请参见网站[www.vega.com](http://www.vega.com)。

### 10.4 Trademark

All the brands as well as trade and company names used are property of their lawful proprietor/originator.

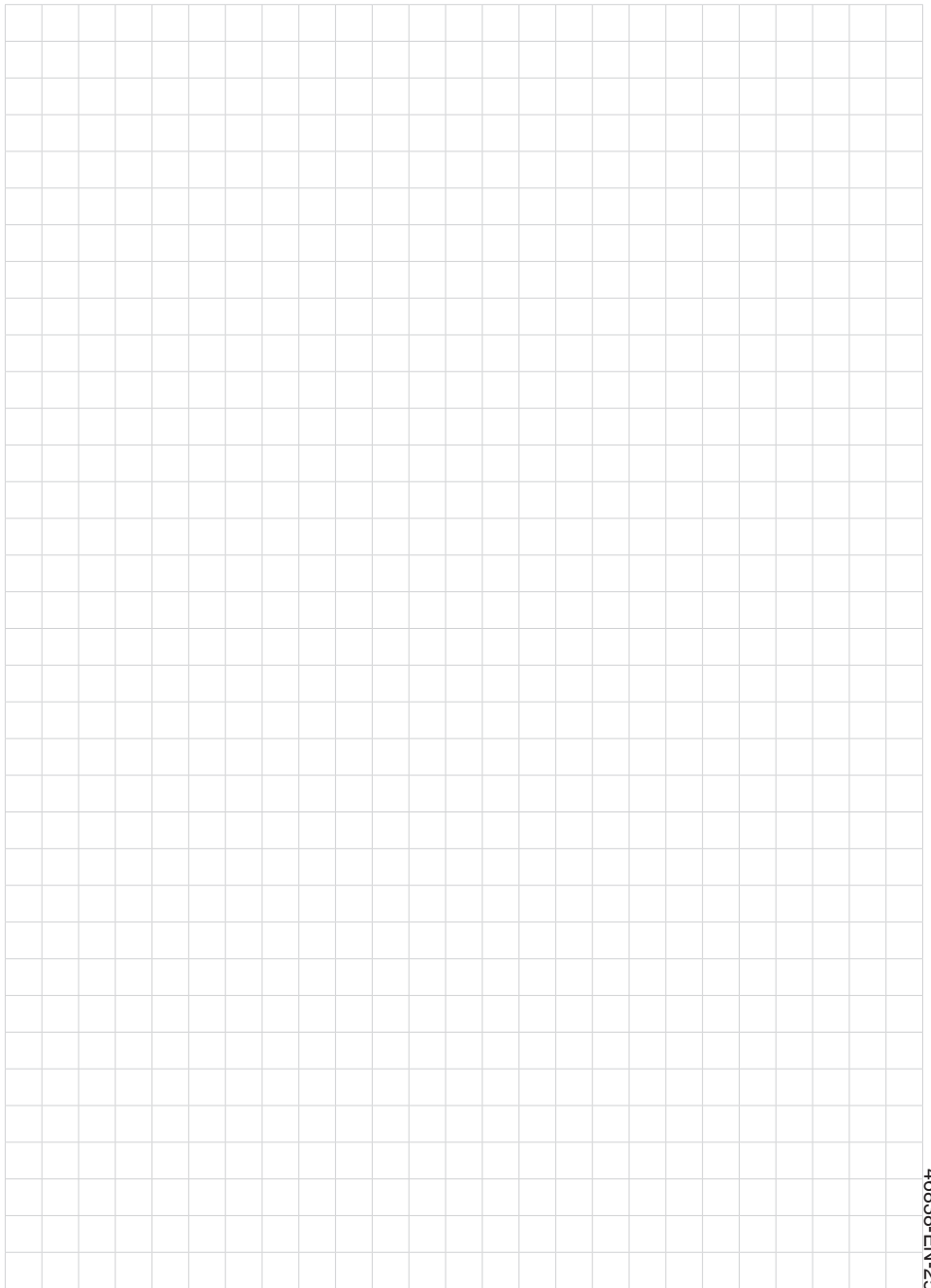



Printing date:

**VEGA**

All statements concerning scope of delivery, application, practical use and operating conditions of the sensors and processing systems correspond to the information available at the time of printing.

Subject to change without prior notice

© VEGA Grieshaber KG, Schiltach/Germany 2025

46838-EN-250605

VEGA Grieshaber KG  
Am Hohenstein 113  
77761 Schiltach  
Germany

Phone +49 7836 50-0  
E-mail: [info.de@vega.com](mailto:info.de@vega.com)  
[www.vega.com](http://www.vega.com)