



## IFC 050 Handbook

Signal converter for electromagnetic flowmeters

Electronic revision:  
ER 3.1.x

The documentation is only complete when used in combination with the relevant documentation for the flow sensor.



<b>1</b>	<b>Safety instructions</b>	<b>6</b>
<hr/>		
1.1	Software history .....	6
1.2	Intended use .....	7
1.3	Certification .....	7
1.4	Safety instructions from the manufacturer .....	8
1.4.1	Copyright and data protection .....	8
1.4.2	Disclaimer .....	8
1.4.3	Product liability and warranty .....	9
1.4.4	Information concerning the documentation .....	9
1.4.5	Warnings and symbols used .....	10
1.5	Safety instructions for the operator .....	10
<b>2</b>	<b>Device description</b>	<b>11</b>
<hr/>		
2.1	Scope of delivery .....	11
2.2	Device description .....	12
2.3	Signal converter/flow sensor combination possibilities .....	12
2.4	Nameplates .....	13
<b>3</b>	<b>Installation</b>	<b>14</b>
<hr/>		
3.1	General notes on installation .....	14
3.2	Storage .....	14
3.3	Transport .....	14
3.4	Installation specifications .....	14
3.5	Mounting of the compact version .....	15
3.6	Mounting of the wall housing, remote version .....	15
<b>4</b>	<b>Electrical connections</b>	<b>17</b>
<hr/>		
4.1	Safety instructions .....	17
4.2	Important notes on electrical connection .....	17
4.3	Electrical cables for remote device versions, notes .....	18
4.3.1	Notes on signal cable A .....	18
4.3.2	Notes on field current cable C .....	18
4.3.3	Requirements for signal cables provided by the customer .....	19
4.4	Preparing the signal and field current cables .....	20
4.4.1	Signal cable A (type DS 300), construction .....	20
4.4.2	Preparing signal cable A, connection to signal converter .....	21
4.4.3	Length of signal cable A .....	23
4.4.4	Preparing field current cable C, connection to signal converter .....	24
4.4.5	Preparing signal cable A, connection to flow sensor .....	26
4.4.6	Preparing field current cable C, connection to flow sensor .....	27
4.5	Connecting the signal and field current cables .....	28
4.5.1	Connecting the signal and field current cables to the signal converter, remote version ...	28
4.5.2	Connection diagram for signal and field current cable .....	29
4.6	Grounding the flow sensor .....	30
4.7	Connecting the power supply .....	30

4.8	Inputs and outputs, overview .....	32
4.8.1	Description of the CG number .....	32
4.8.2	Fixed, non-alterable output versions .....	32
4.9	Description of the inputs and outputs .....	33
4.9.1	Current output .....	33
4.9.2	Pulse output and frequency output .....	34
4.9.3	Status output and limit switch .....	35
4.10	Electrical connection of the outputs .....	36
4.10.1	Electrical connection of the outputs.....	36
4.10.2	Laying electrical cables correctly.....	37
4.11	Connection diagrams of outputs .....	37
4.11.1	Important notes.....	37
4.11.2	Description of the electrical symbols.....	38
4.11.3	Basic and Modbus outputs.....	39
4.11.4	HART connection.....	43
5	Start-up .....	44
<hr/>		
5.1	Switching on the power .....	44
5.2	Starting the signal converter .....	44
6	Operation .....	45
<hr/>		
6.1	Safety instructions for the use of the magnet pencil.....	45
6.2	Display and operating elements .....	45
6.2.1	Display in measuring mode with 2 or 3 measured values .....	48
6.2.2	Display for selection of submenu and functions in menu mode.....	48
6.2.3	Display when setting a parameter in parameter and data mode .....	49
6.2.4	Display for selection of submenu and functions with preview.....	49
6.3	Menu structure .....	50
6.4	Function tables .....	52
6.4.1	Menu "A quick setup".....	52
6.4.2	Menu "B test" .....	54
6.4.3	Menu "C setup" .....	55
6.4.4	Set free units.....	64
6.5	Description of functions .....	65
6.5.1	Reset counter in the menu "quick setup" .....	65
6.5.2	Deleting error messages in the menu "quick setup".....	65
6.5.3	Conductivity measurement.....	66
6.6	Status messages and diagnostic information.....	66
7	Service .....	71
<hr/>		
7.1	Spare parts availability.....	71
7.2	Availability of services .....	71
7.3	Returning the device to the manufacturer.....	71
7.3.1	General information.....	71
7.3.2	Form (for copying) to accompany a returned device.....	72
7.4	Disposal .....	72

8	Technical data	73
8.1	Measuring principle.....	73
8.2	Technical data.....	74
8.3	Dimensions and weight .....	81
8.3.1	Housing .....	81
8.3.2	Mounting plate, wall version.....	83
8.4	Flow tables .....	84
8.5	Measuring accuracy .....	86
9	Description of HART interface	87
9.1	General description .....	87
9.2	Software history .....	87
9.3	Connection variants.....	88
9.3.1	Point-to-Point connection - analogue / digital mode.....	89
9.3.2	Multi-drop connection (2-wire connection).....	90
9.3.3	Multi-drop connection (3-wire connection).....	91
9.4	Inputs/outputs and HART dynamic variables and device variables .....	92
10	Notes	94

## 1.1 Software history

The "Electronic Revision" (ER) is consulted to document the revision status of electronic equipment according to NE 53 for all devices. It is easy to see from the ER whether troubleshooting or larger changes in the electronic equipment have taken place and how that has affected the compatibility.

1	Downwards compatible changes and fault repair with no effect on operation (e.g. spelling mistakes on display)	
2- <u>  </u>	Downwards compatible hardware and/or software change of interfaces:	
	H	HART®
	M	Modbus
	X	all interfaces
3- <u>  </u>	Downwards compatible hardware and/or software change of inputs and outputs:	
	I	Current output
	F, P	Frequency / pulse output
	S	Status output
	L	Limit switch
	X	all inputs and outputs
4	Downwards compatible changes with new functions	
5	Incompatible changes, i.e. electronic equipment must be changed	

Table 1-1: Description of changes



### INFORMATION!

In the table below, "  " is a placeholder for possible multi-digit alphanumeric combinations, depending on the available version.

Release date (ER)	Electronic revision (ER)	Changes and compatibility	Documentation
2012	ER 3.0.0_ <u>  </u>	-	MA IFC 050 R01
2012	ER 3.0.1_ <u>  </u>	1	MA IFC 050 R01
2013	ER 3.0.2_ <u>  </u>	1; 4	MA IFC 050 R03
2014	ER 3.0.3_ <u>  </u>	1; 3-F; 3-P; 4	MA IFC 050 R03
2020	ER 3.1.0_ <u>  </u>	1; 2-M; 4	MA IFC 050 R04
2021	ER 3.1.1_ <u>  </u>	2-X; 4	

Table 1-2: Changes and effect on compatibility

## 1.2 Intended use

The electromagnetic flowmeters are designed exclusively to measure the flow and conductivity of electrically conductive, liquid media.



**WARNING!**

*If the device is not used according to the operating conditions (refer to chapter "Technical data"), the intended protection could be affected.*



**INFORMATION!**

*This device is a Group 1, Class A device as specified within CISPR11. It is intended for use in industrial environment. There may be potential difficulties in ensuring electromagnetic compatibility in other environments, due to conducted as well as radiated disturbances.*

## 1.3 Certification

### Product marking



Figure 1-1: Examples of marking logo

The manufacturer certifies successful testing of the product by applying the conformity mark on the device.

**This device fulfils the statutory requirements of the relevant directives.**

For more information on the directives, standards and the approved certifications, please refer to the declaration of conformity supplied with the device or downloadable from the manufacturer's website.

## 1.4 Safety instructions from the manufacturer

### 1.4.1 Copyright and data protection

The contents of this document have been created with great care. Nevertheless, we provide no guarantee that the contents are correct, complete or up-to-date.

The contents and works in this document are subject to copyright. Contributions from third parties are identified as such. Reproduction, processing, dissemination and any type of use beyond what is permitted under copyright requires written authorisation from the respective author and/or the manufacturer.

The manufacturer tries always to observe the copyrights of others, and to draw on works created in-house or works in the public domain.

The collection of personal data (such as names, street addresses or e-mail addresses) in the manufacturer's documents is always on a voluntary basis whenever possible. Whenever feasible, it is always possible to make use of the offerings and services without providing any personal data.

We draw your attention to the fact that data transmission over the Internet (e.g. when communicating by e-mail) may involve gaps in security. It is not possible to protect such data completely against access by third parties.

We hereby expressly prohibit the use of the contact data published as part of our duty to publish an imprint for the purpose of sending us any advertising or informational materials that we have not expressly requested.

### 1.4.2 Disclaimer

The manufacturer will not be liable for any damage of any kind by using its product, including, but not limited to direct, indirect or incidental and consequential damages.

This disclaimer does not apply in case the manufacturer has acted on purpose or with gross negligence. In the event any applicable law does not allow such limitations on implied warranties or the exclusion of limitation of certain damages, you may, if such law applies to you, not be subject to some or all of the above disclaimer, exclusions or limitations.

Any product purchased from the manufacturer is warranted in accordance with the relevant product documentation and our Terms and Conditions of Sale.

The manufacturer reserves the right to alter the content of its documents, including this disclaimer in any way, at any time, for any reason, without prior notification, and will not be liable in any way for possible consequences of such changes.

### 1.4.3 Product liability and warranty

The operator shall bear responsibility for the suitability of the device for the specific purpose. The manufacturer accepts no liability for the consequences of misuse by the operator. Improper installation or operation of the devices (systems) will cause the warranty to be void. The respective "Standard Terms and Conditions" which form the basis for the sales contract shall also apply.

### 1.4.4 Information concerning the documentation

To prevent any injury to the user or damage to the device it is essential that you read the information in this document and observe applicable national standards, safety requirements and accident prevention regulations.

If this document is not in your native language and if you have any problems understanding the text, we advise you to contact your local office for assistance. The manufacturer cannot accept responsibility for any damage or injury caused by misunderstanding of the information in this document.

This document is provided to help you establish operating conditions, which will permit safe and efficient use of this device. Special considerations and precautions are also described in the document, which appear in the form of icons as shown below.

### 1.4.5 Warnings and symbols used

Safety warnings are indicated by the following symbols.



**DANGER!**

*This warning refers to the immediate danger when working with electricity.*



**DANGER!**

*This warning refers to the immediate danger of burns caused by heat or hot surfaces.*



**DANGER!**

*This warning refers to the immediate danger when using this device in a hazardous atmosphere.*



**DANGER!**

*These warnings must be observed without fail. Even partial disregard of this warning can lead to serious health problems and even death. There is also the risk of seriously damaging the device or parts of the operator's plant.*



**WARNING!**

*Disregarding this safety warning, even if only in part, poses the risk of serious health problems. There is also the risk of damaging the device or parts of the operator's plant.*



**CAUTION!**

*Disregarding these instructions can result in damage to the device or to parts of the operator's plant.*



**INFORMATION!**

*These instructions contain important information for the handling of the device.*



**LEGAL NOTICE!**

*This note contains information on statutory directives and standards.*



• **HANDLING**

This symbol designates all instructions for actions to be carried out by the operator in the specified sequence.

➔ **RESULT**

This symbol refers to all important consequences of the previous actions.

## 1.5 Safety instructions for the operator



**WARNING!**

*In general, devices from the manufacturer may only be installed, commissioned, operated and maintained by properly trained and authorized personnel.*

*This document is provided to help you establish operating conditions, which will permit safe and efficient use of this device.*

## 2.1 Scope of delivery

**INFORMATION!**

Inspect the packaging carefully for damages or signs of rough handling. Report damage to the carrier and to the local office of the manufacturer.

**INFORMATION!**

Do a check of the packing list to make sure that you have all the elements given in the order.

**INFORMATION!**

Look at the device nameplate to ensure that the device is delivered according to your order. Check for the correct supply voltage printed on the nameplate.

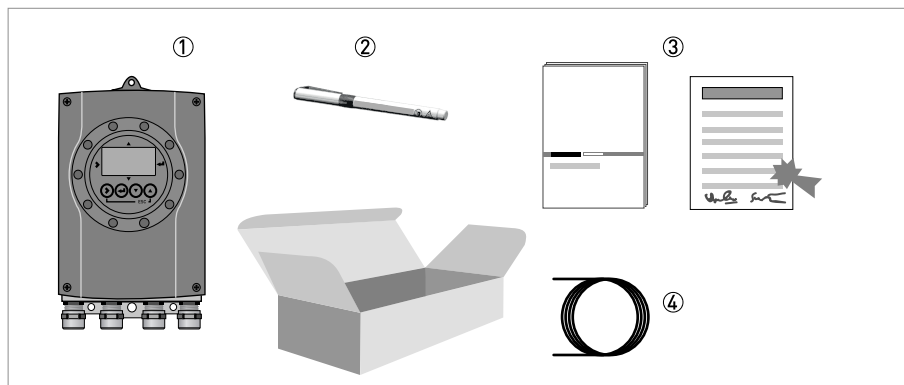

Figure 2-1: Scope of delivery

- ① Device in the version as ordered
- ② Magnet pencil (to operate the signal converter when the housing is closed)
- ③ Documentation (calibration report, product documentation for flow sensor and signal converter)
- ④ Signal cable (only for remote version)

## 2.2 Device description

Electromagnetic flowmeters are designed exclusively to measure the flow and conductivity of electrically conductive, liquid media.

Your measuring device is supplied ready for operation. The factory settings for the operating data have been made in accordance with your order specifications.

**The following versions are available:**

- Compact version (the signal converter is mounted directly on the flow sensor)
- Remote version (electrical connection to the flow sensor via field current and signal cable)

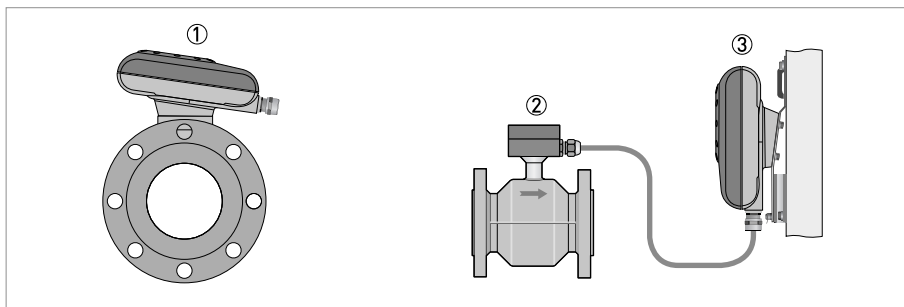

Figure 2-2: Device versions

- ① Compact version
- ② Flow sensor with connection box
- ③ Wall version

## 2.3 Signal converter/flow sensor combination possibilities

Flow sensor	Flow sensor + signal converter IFC 050	
	Compact	Remote wall-mounted housing
OPTIFLUX 1000	OPTIFLUX 1050 C	OPTIFLUX 1050 W
OPTIFLUX 2000	OPTIFLUX 2050 C	OPTIFLUX 2050 W
OPTIFLUX 4000	OPTIFLUX 4050 C	OPTIFLUX 4050 W
OPTIFLUX 5000	OPTIFLUX 5050 C	OPTIFLUX 5050 W
OPTIFLUX 6000	OPTIFLUX 6050 C	OPTIFLUX 6050 W
WATERFLUX 3000	WATERFLUX 3050 C	WATERFLUX 3050 W

Table 2-1: Signal converter/flow sensor combination possibilities

## 2.4 Nameplates



### INFORMATION!

Look at the device nameplate to ensure that the device is delivered according to your order. Check for the correct supply voltage printed on the nameplate.

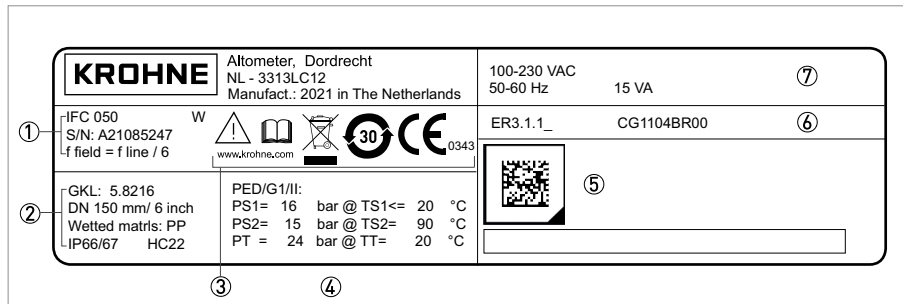

Figure 2-3: Example of a nameplate

- ① Product type  
Serial number  
Field frequency values
- ② GKL value (flow sensor constant)  
Size (mm/inch)  
Wetted materials  
Ingress protection
- ③ Safety instructions, disposal, China RoHs marking and conformity mark
- ④ PED data
- ⑤ Auto ID according to DIN SPEC 91406
- ⑥ Electronic revision (ER) and CG number
- ⑦ Data for power supply

### Auto ID according to DIN SPEC 91406

The auto ID code guides you directly to the PICK server (Product Information Center KROHNE). Scan the code on the nameplate to download all available product documentation and software:

- Handbooks
- Quick Starts
- Supplementary manuals
- Calibration certificates
- Factory settings as .bin file
- Parameter datasheets
- Digital nameplates
- ...

### 3.1 General notes on installation

**INFORMATION!**

*Inspect the packaging carefully for damages or signs of rough handling. Report damage to the carrier and to the local office of the manufacturer.*

**INFORMATION!**

*Do a check of the packing list to make sure that you have all the elements given in the order.*

**INFORMATION!**

*Look at the device nameplate to ensure that the device is delivered according to your order. Check for the correct supply voltage printed on the nameplate.*

### 3.2 Storage

- Store the device in a dry, dust-free location.
- Avoid continuous direct sunlight.
- Store the device in its original packing.
- Storage temperature: -40...+70°C / -40...+158°F

### 3.3 Transport

**Signal converter**

- No special requirements.

**Compact version**

- Do not lift the device by the signal converter housing.
- Do not use lifting chains.
- To transport flange devices, use lifting straps. Wrap these around both process connections.

### 3.4 Installation specifications

**INFORMATION!**

*The following precautions must be taken to ensure reliable installation.*

- *Make sure that there is adequate space to the sides.*
- *The device must not be heated by radiated heat (e.g. exposure to the sun) to an electronics housing surface temperature above the maximum permissible ambient temperature. If it is necessary to prevent damage from heat sources, a heat protection (e.g. sun shade) has to be installed.*
- *Signal converters installed in control cabinets require adequate cooling, e.g. by fan or heat exchanger.*
- *Do not expose the signal converter to intense vibrations. The measuring devices are tested for a vibration level as described in the chapter "Technical data".*

### 3.5 Mounting of the compact version



**INFORMATION!**

The signal converter is mounted directly on the flow sensor. For installation of the flowmeter, please observe the instructions in the supplied product documentation for the flow sensor.

### 3.6 Mounting of the wall housing, remote version



**INFORMATION!**

Assembly materials and tools are not part of the delivery. Use the assembly materials and tools in compliance with the applicable occupational health and safety directives.

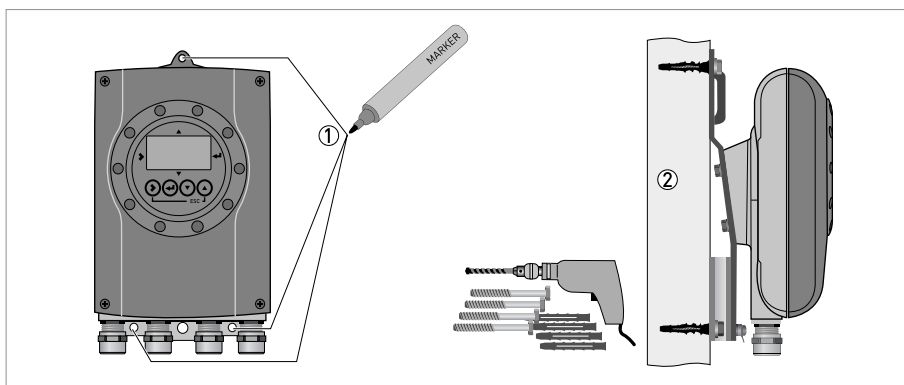

Figure 3-1: Mounting of the wall housing



- ① Prepare the holes with the aid of the mounting plate. For further information refer to *Mounting plate, wall version* on page 83.
- ② Fasten the device securely to the wall with the mounting plate.

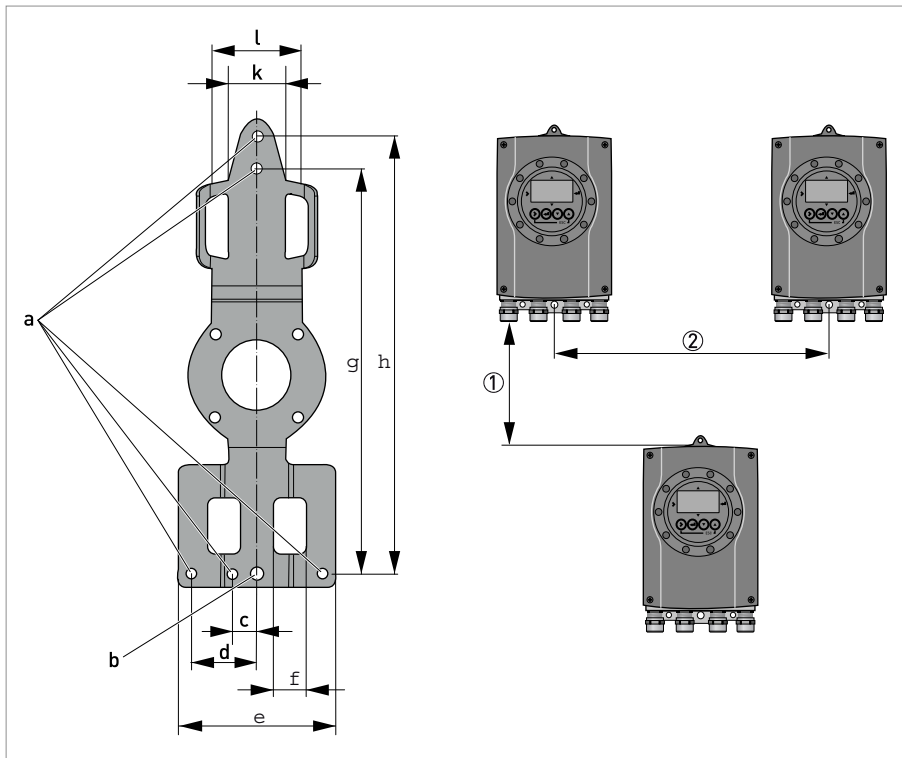

Figure 3-2: Dimensions of mounting plate and distances when mounting multiple devices next to each other

- ① 277 mm / 10.89"
- ② 310 mm / 12.2"

	[mm]	[inch]
a	Ø6.5	Ø0.26
b	Ø8.1	Ø0.3
c	15	0.6
d	40	1.6
e	96	3.8
f	20	0.8
g	248	9.8
h	268	10.5
k	35	1.4
l	55	2.2

Table 3-1: Dimensions in mm and inch

## 4.1 Safety instructions

**DANGER!**

All work on the electrical connections may only be carried out with the power disconnected.  
Take note of the voltage data on the nameplate!

**DANGER!**

Observe the national regulations for electrical installations!

**WARNING!**

Observe without fail the local occupational health and safety regulations.  
Any work done on the electrical components of the measuring device may only be carried out by properly trained specialists.

**INFORMATION!**

Look at the device nameplate to ensure that the device is delivered according to your order.  
Check for the correct supply voltage printed on the nameplate.

## 4.2 Important notes on electrical connection

**DANGER!**

Electrical connection is carried out in conformity with the VDE 0100 directive "Regulations for electrical power installations with line voltages up to 1000 V" or equivalent national regulations.

**DANGER!**

The device must be grounded in accordance with regulations in order to protect personnel against electric shocks.

**CAUTION!**

- Use suitable cable entries for the various electrical cables.
- The flow sensor and signal converter have been configured together at the factory. For this reason, please connect the devices in pairs. Ensure that the flow sensor constant GKL (refer to information on the nameplates) are identically set.
- If delivered separately or when installing devices that were not configured together, set the signal converter to the DN size and GKL of the flow sensor, refer to Function tables on page 52.

## 4.3 Electrical cables for remote device versions, notes

### 4.3.1 Notes on signal cable A



**INFORMATION!**

*Signal cable A (type DS 300) with double shield ensures proper transmission of measured values.*

**Observe the following notes:**

- Lay the signal cable with fastening elements.
- It is permissible to lay the signal cable in water or in the ground.
- The insulating material is flame-retardant.
- The signal cable does not contain any halogens and is unplasticized, and remains flexible at low temperatures.
- The connection of the inner shield (10) is carried out via the stranded drain wire (1).
- The connection of the outer shield (60) is carried out via the stranded drain wire (6).

### 4.3.2 Notes on field current cable C



**DANGER!**

*A shielded 2-wire copper cable is used for the field current cable. The shielding **MUST** be connected in the housing of the flow sensor and signal converter.*



**INFORMATION!**

*The field current cable is not part of the scope of delivery.*

### 4.3.3 Requirements for signal cables provided by the customer

**INFORMATION!**

*If the signal cable was not ordered, it is to be provided by the customer.*

*The following requirements regarding the electrical values of the signal cable must be observed:*

**Electrical safety**

- According to low voltage directive or equivalent national regulations.

**Capacitance of the insulated conductors**

- Insulated conductor / insulated conductor < 50 pF/m
- Insulated conductor / shield < 150 pF/m

**Insulation resistance**

- $R_{iso} > 100 \text{ G}\Omega \times \text{km}$
- $U_{max} < 24 \text{ V}$
- $I_{max} < 100 \text{ mA}$

**Test voltages**

- Insulated conductor / inner shield 500 V
- Insulated conductor / insulated conductor 1000 V
- Insulated conductor / outer shield 1000 V

**Twisting of the insulated conductors**

- At least 10 twists per meter, important for screening magnetic fields.

## 4.4 Preparing the signal and field current cables



### INFORMATION!

Assembly materials and tools are not part of the delivery. Use the assembly materials and tools in compliance with the applicable occupational health and safety directives.

### 4.4.1 Signal cable A (type DS 300), construction

- Signal cable A is a double-shielded cable for signal transmission between the flow sensor and signal converter.
- Bending radius:  $\geq 50 \text{ mm} / 2''$

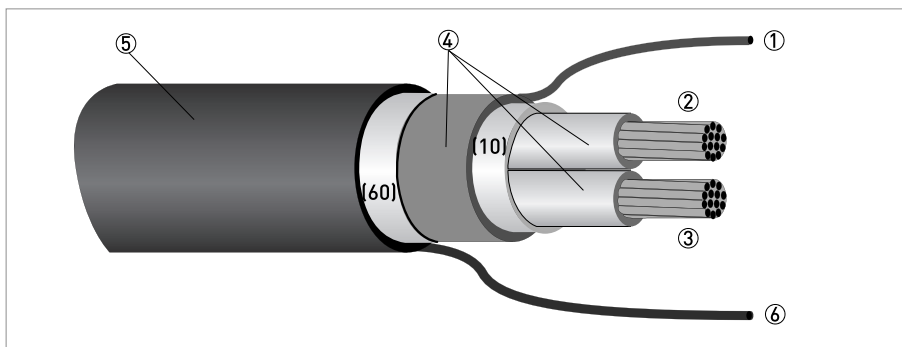

Figure 4-1: Construction of signal cable A (standard version)

- ① Stranded drain wire (1) for the inner shield (10),  $1.0 \text{ mm}^2 \text{ Cu}$  / AWG 17 (not insulated, bare)
- ② Insulated wire (2),  $0.5 \text{ mm}^2 \text{ Cu}$  / AWG 20
- ③ Insulated wire (3),  $0.5 \text{ mm}^2 \text{ Cu}$  / AWG 20
- ④ Insulation layers
- ⑤ Outer sheath
- ⑥ Stranded drain wire (6) for the outer shield (60)

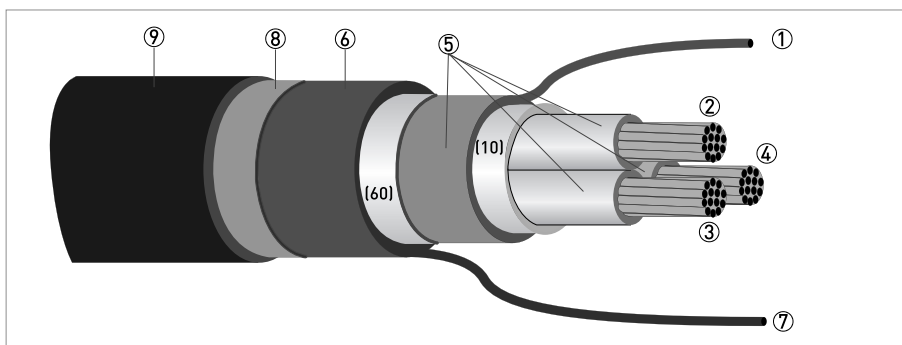

Figure 4-2: Construction of signal cable A (armoured version)

- ① Stranded drain wire (1) for the inner shield (10),  $1.0 \text{ mm}^2 \text{ Cu}$  / AWG 17 (not insulated, bare)
- ② Insulated wire (2),  $0.5 \text{ mm}^2 \text{ Cu}$  / AWG 20
- ③ Insulated wire (3),  $0.5 \text{ mm}^2 \text{ Cu}$  / AWG 20
- ④ Insulated wire (4),  $0.5 \text{ mm}^2 \text{ Cu}$  / AWG 20
- ⑤ Insulation layers
- ⑥ Outer sheath
- ⑦ Stranded drain wire (7) for the outer shield (60)
- ⑧ Armoured braiding layer
- ⑨ Outer jacket

#### 4.4.2 Preparing signal cable A, connection to signal converter



##### INFORMATION!

Assembly materials and tools are not part of the delivery. Use the assembly materials and tools in compliance with the applicable occupational health and safety directives.

- Connection of the two shields in the signal converter is carried out via the stranded drain wires.
- Bending radius:  $\geq 50 \text{ mm} / 2''$

##### Required materials

- PVC insulating tube,  $\varnothing 2.5 \text{ mm} / 0.1''$
- Heat-shrinkable tubing
- 2 wire end ferrules to DIN 46228: E 1.5-8 for the stranded drain wires (1), (6)
- 2 wire end ferrules to DIN 46228: E 0.5-8 for the insulated conductors 2, 3

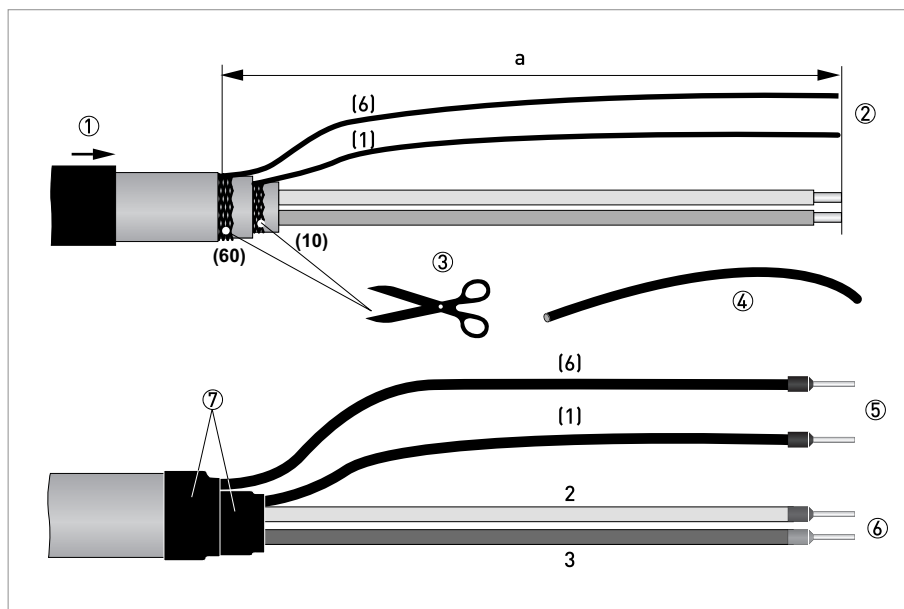

Figure 4-3: Preparation of signal cable A (standard version)

$a = 80 \text{ mm} / 3.15''$



- ① Pull the heat-shrinkable tubing over the signal cable.
- ② Strip the conductor to dimension a.
- ③ Cut off the inner shield (10) and the outer shield (60). Make sure not to damage the stranded drain wires (1), (6).
- ④ Slide the insulating tubes over the stranded drain wires (1), (6).
- ⑤ Crimp the wire end ferrules onto the stranded drain wire.
- ⑥ Crimp the wire end ferrules onto the conductors 2, 3.
- ⑦ Shrink the heat-shrinkable tubing.



### 4.4.3 Length of signal cable A



**INFORMATION!**

For temperatures of the medium above 150°C / 300°F, a special signal cable and a ZD intermediate socket are necessary. These are available including the changed electrical connection diagrams.

Flow sensor	Nominal size		Min. electrical conductivity [μS/cm]	Curve for signal cable A
	DN [mm]	[inch]		
OPTIFLUX 1000 F	10...150	3/8...6	20	A1
OPTIFLUX 2000 F	25...150	1...6	20	A1
	200...1200	8...48	20	A2
OPTIFLUX 4000 F	10...150	3/8...6	20	A1
	200...1200	8...48	20	A2
OPTIFLUX 5000 F	2.5...100	1/10...4	20	A1
	150...250	6...10	20	A2
OPTIFLUX 6000 F	10...150	3/8...6	20	A1
WATERFLUX 3000 F	25...600	1...24	20	A1

Table 4-1: Length of signal cable A

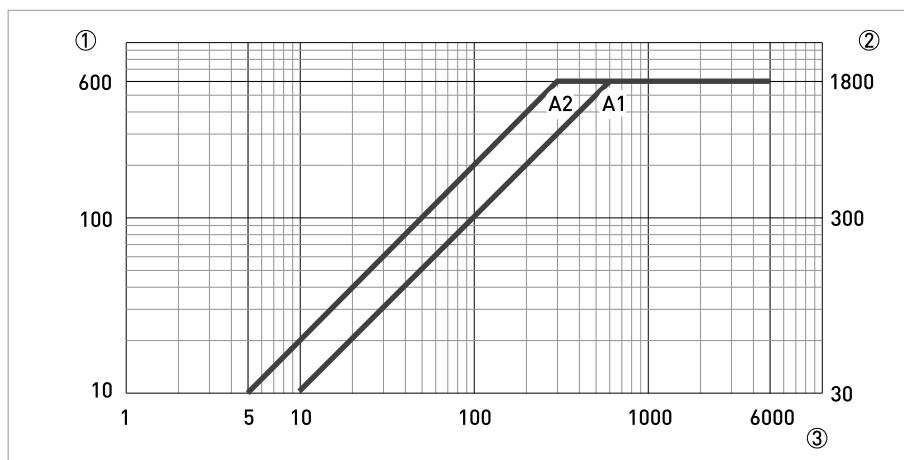

Figure 4-5: Maximum length of signal cable A

- ① Maximum length of signal cable A between the flow sensor and signal converter [m]
- ② Maximum length of signal cable A between the flow sensor and signal converter [ft]
- ③ Electrical conductivity of the medium being measured [μS/cm]

## 4.4.4 Preparing field current cable C, connection to signal converter

**DANGER!**

A shielded 2-wire copper cable is used as the field current cable. The shielding **MUST** be connected in the housing of the flow sensor and signal converter.

**INFORMATION!**

Assembly materials and tools are not part of the delivery. Use the assembly materials and tools in compliance with the applicable occupational health and safety directives.

- Field current cable C is not part of the scope of delivery.
- Bending radius:  $\geq 50 \text{ mm} / 2''$

**Required materials:**

- Shielded, at least 2-wire copper cable with suitable heat-shrinkable tubing
- Insulating tube, size according to the cable being used
- Wire end ferrules to DIN 46228: size according to the cable being used

Length		Cross-section $A_F$ (Cu)	
[m]	[ft]	[mm <sup>2</sup> ]	[AWG]
0...150	0...492	2 x 0.75 Cu ①	2 x 18
150...300	492...984	2 x 1.5 Cu ①	2 x 14
300...600	984...1968	2 x 2.5 Cu ①	2 x 12

Table 4-2: Length and cross-section of field current cable C

① Cu = copper cross-section

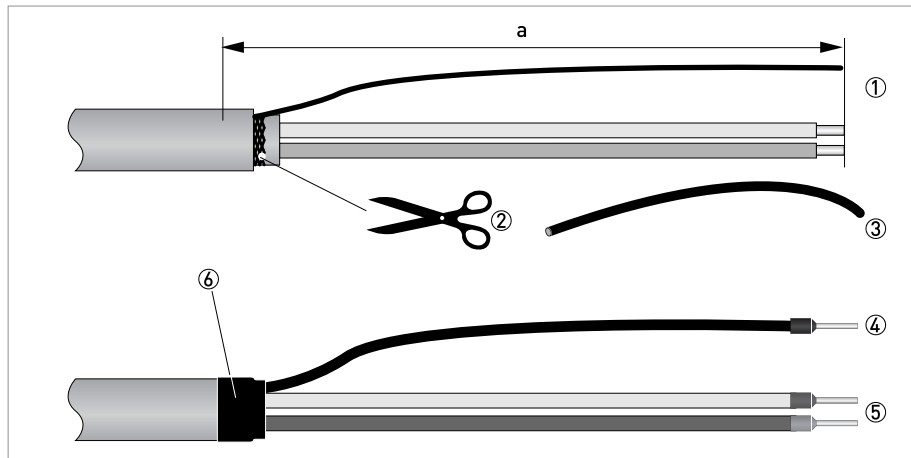

Figure 4-6: Field current cable C, preparation for the signal converter

$a = 80 \text{ mm} / 3.15''$



- ① Strip the conductor to dimension a.
- ② If a stranded drain wire is present, remove the shield that is present. Make sure not to damage the stranded drain wire.
- ③ Slide an insulating tube over the stranded drain wire.
- ④ Crimp a wire end ferrule onto the stranded drain wire.
- ⑤ Crimp the wire end ferrules on the conductors.
- ⑥ Pull a shrinkable tube over the prepared cable.

## 4.4.5 Preparing signal cable A, connection to flow sensor

**INFORMATION!**

Assembly materials and tools are not part of the delivery. Use the assembly materials and tools in compliance with the applicable occupational health and safety directives.

- The outer shield (60) is connected in the terminal compartment of the flow sensor directly via the shield and a clip.
- Bending radius:  $\geq 50 \text{ mm} / 2''$

**Required materials**

- PVC insulating tube,  $\varnothing 2.0 \dots 2.5 \text{ mm} / 0.08 \dots 0.1''$
- Heat-shrinkable tubing
- Wire end ferrule to DIN 46228: E 1.5-8 for the stranded drain wire (1)
- 2 wire end ferrules to DIN 46228: E 0.5-8 for the insulated conductors 2, 3

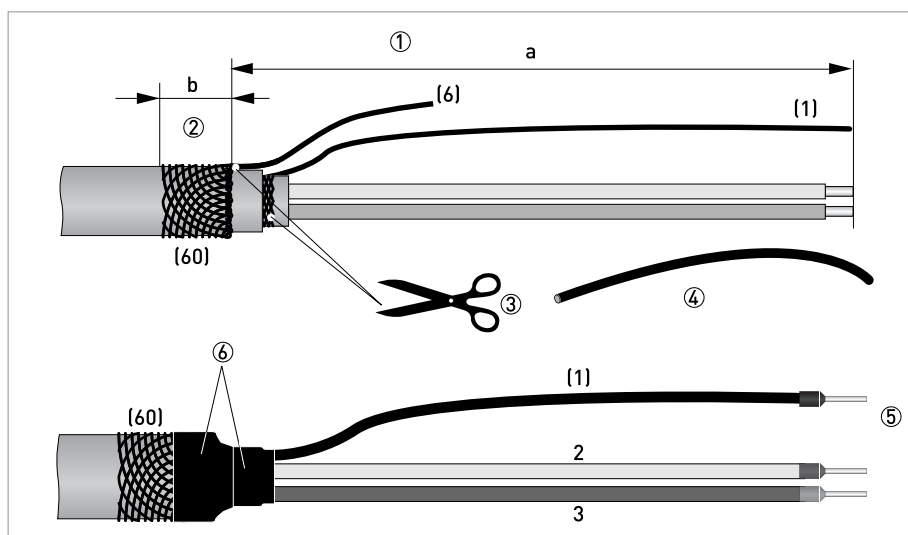

Figure 4-7: Preparing signal cable A, connection to flow sensor

$a = 50 \text{ mm} / 2''$

$b = 10 \text{ mm} / 0.4''$



- ① Strip the conductor to dimension a.
- ② Trim the outer shield (60) to dimension b and pull it over the outer sheath.
- ③ Remove the stranded drain wire (6) of the outer shield and the inner shield. Make sure not to damage the stranded drain wire (1) of the inner shield.
- ④ Slide an insulating tube over the stranded drain wire (1).
- ⑤ Crimp the wire end ferrules onto conductors 2 and 3 and the stranded drain wire (1).
- ⑥ Pull the heat-shrinkable tubing over the prepared signal cable.

#### 4.4.6 Preparing field current cable C, connection to flow sensor



##### **INFORMATION!**

Assembly materials and tools are not part of the delivery. Use the assembly materials and tools in compliance with the applicable occupational health and safety directives.

- The field current cable is not part of the scope of delivery.
- The shield is connected in the terminal compartment of the flow sensor directly via the shield and a clip.
- Bending radius:  $\geq 50 \text{ mm} / 2''$

##### **Required materials**

- Shielded 2-wire insulated copper cable
- Insulating tube, size according to the cable being used
- Heat-shrinkable tubing
- 2 wire end ferrules to DIN 46228: size according to the cable being used

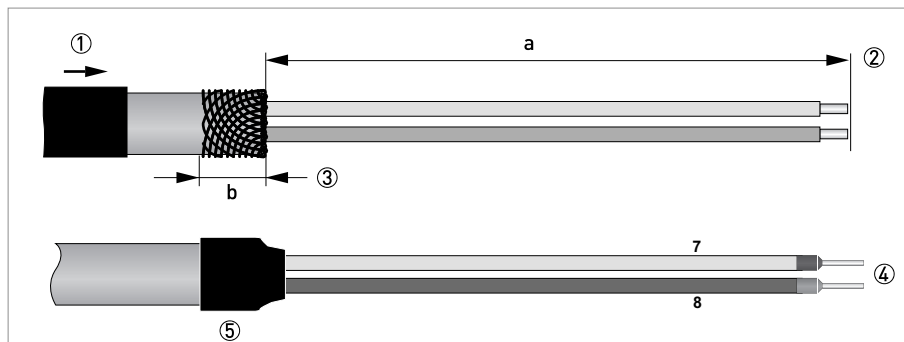

Figure 4-8: Preparation of field current cable C

$a = 50 \text{ mm} / 2''$

$b = 10 \text{ mm} / 0.4''$



- ① Pull the heat-shrinkable tubing over the signal cable.
- ② Strip the conductor to dimension a.
- ③ Trim the outer shield to dimension b and pull it over the outer sheath.
- ④ Crimp the wire end ferrules onto both conductors 7, 8.
- ⑤ Shrink the heat-shrinkable tubing.

## 4.5 Connecting the signal and field current cables



### **DANGER!**

Cables may only be connected when the power is switched off.



### **DANGER!**

The device must be grounded in accordance with regulations in order to protect personnel against electric shocks.



### **WARNING!**

Observe without fail the local occupational health and safety regulations.

Any work done on the electrical components of the measuring device may only be carried out by properly trained specialists.

### 4.5.1 Connecting the signal and field current cables to the signal converter, remote version



### **INFORMATION!**

The compact version is supplied pre-assembled from the factory.



### **Connect the electrical conductors as follows:**

- ① Press with a screwdriver in the slot on the spring terminal.
- ② Insert the electrical conductor into the plug.
- ③ The conductor will be clamped as soon as the screwdriver is pulled out of the slot.

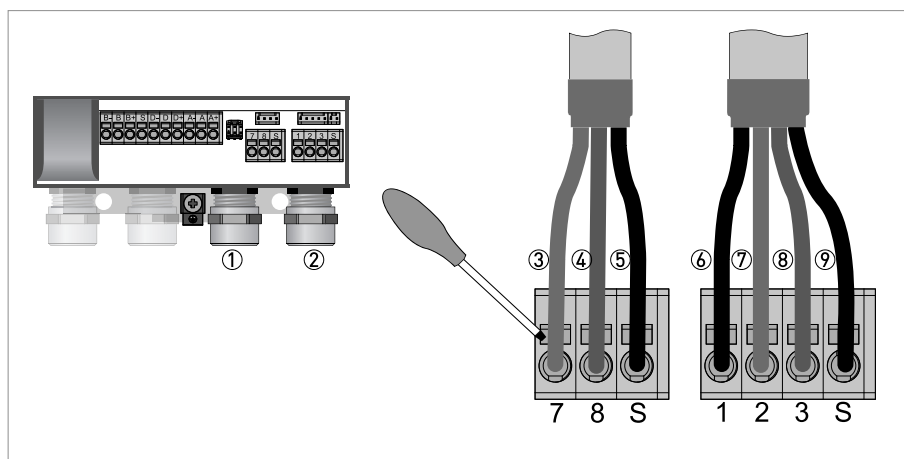

Figure 4-9: Connecting the signal and field current cables

- ① Cable entry for field current cable
- ② Cable entry for signal cable
- ③ Electrical conductor (7)
- ④ Electrical conductor (8)
- ⑤ Connecting the field current cable shield
- ⑥ Stranded drain wire (1) of the inner shield (10) of the signal cable
- ⑦ Electrical conductor (2)
- ⑧ Electrical conductor (3)
- ⑨ Stranded drain wire (S) of the outer shield (60)

#### 4.5.2 Connection diagram for signal and field current cable



**DANGER!**

The device must be grounded in accordance with regulations in order to protect personnel against electric shocks.

- A shielded 2-wire copper cable is used as the field current cable. The shielding **MUST** be connected in the housing of the flow sensor and signal converter.
- The outer shield (60) is connected in the terminal compartment of the flow sensor directly via the shield and a clip.
- Bending radius of signal and field current cable:  $\geq 50 \text{ mm} / 2''$
- The following illustration is schematic. The positions of the electrical connection terminals may vary depending on the housing version.

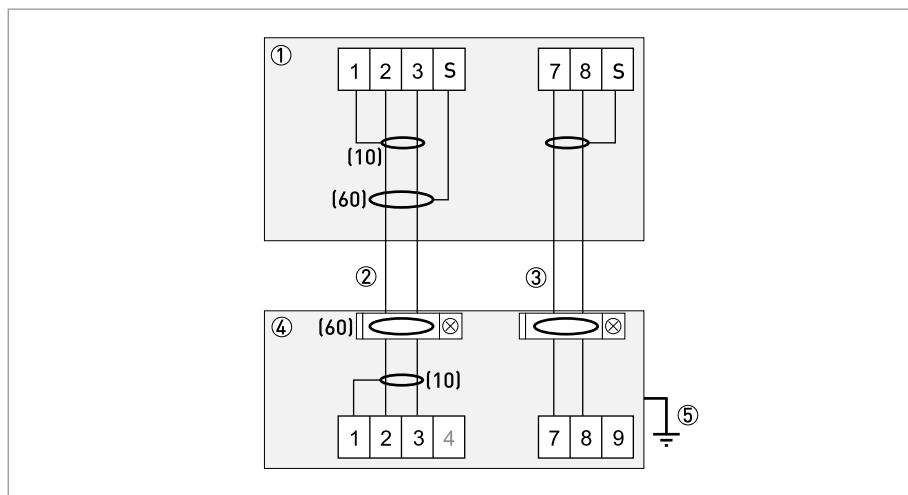

Figure 4-10: Connection diagram for signal and field current cable

- ① Electrical terminal compartment in the signal converter
- ② Signal cable A (type DS 300)
- ③ Field current cable C (type LiYCY)
- ④ Electrical terminal compartment in the flow sensor
- ⑤ Functional ground FE
- (10) inner cable shield
- (60) outer cable shield

## 4.6 Grounding the flow sensor



### **CAUTION!**

*There should be no difference in potential between the flow sensor and the housing or protective earth of the signal converter!*

- The flow sensor must be properly grounded.
- The grounding cable should not transmit any interference voltages.
- Do not use the grounding cable to connect any other electrical devices to ground at the same time.
- The flow sensors are connected to ground by means of a functional grounding conductor FE.
- Special grounding instructions for the various flow sensors are provided in the separate documentation for the flow sensor.
- The documentation for the flow sensor also contain descriptions on how to use grounding rings and how to install the flow sensor in metal or plastic pipes or in pipes which are coated on the inside.

## 4.7 Connecting the power supply



### **DANGER!**

- *To protect operators from electrical shock, during installation the cable for the power supply **must** be run with sheathing insulation up to the mains cover. The insulated individual wires have to be only below the mains cover!*
- *If there is no mains cover or if it has been lost, the 100...230 VAC device may only be operated from the outside (with a magnet pencil) while closed!*
- The housings of the devices, which are designed to protect the electronic equipment from dust and moisture, should be kept well closed at all times. Creepage distances and clearances are dimensioned to VDE 0110 and IEC 60664 for pollution severity 2. Supply circuits are designed for overvoltage category III and the output circuits for overvoltage category II.
- Fuse protection ( $I_N \leq 16$  A) for the infeed power circuit, and also a separator (switch, circuit breaker) to isolate the signal converter should be provided for the device in accordance with applicable regulations.

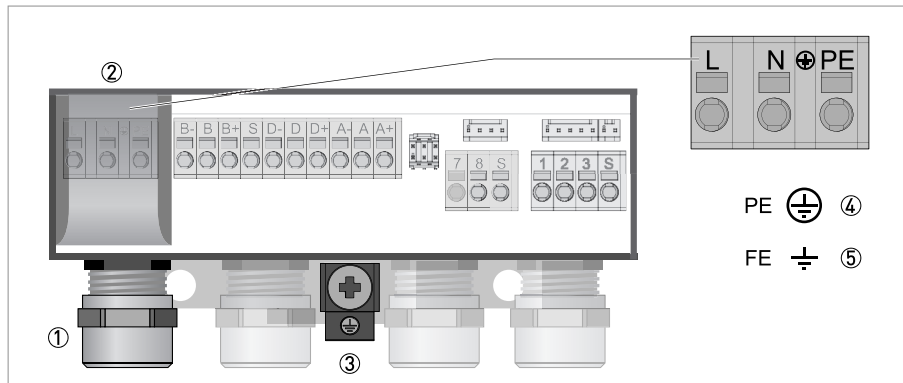

Figure 4-11: Terminal compartment for power

- ① Cable entry for power supply
- ② Mains cover
- ③ Ground terminal
- ④ 100...230 VAC (-15% / +10%)
- ⑤ 24 VDC (-30% / +30%)



- To open the cover of the electrical terminal compartment, lightly press in the side walls of the mains cover ②.
- Flip the mains cover up.
- Connect the power supply.
- Close the mains cover again by flipping it down.

### 100...230 VAC (tolerance range: -15% / +10%)

- Note the power supply voltage and frequency (50...60 Hz) on the nameplate.



#### **INFORMATION!**

240 VAC + 5% is included in the tolerance range.

### 24 VDC (tolerance range: -30% / +30%)

- Note the data on the nameplate!

## 4.8 Inputs and outputs, overview

### 4.8.1 Description of the CG number



Figure 4-12: Marking [CG number] of the electronics module and output variants

- ① ID number: 0
- ② ID number: 0 = standard; 9 = special
- ③ Power supply
- ④ Display (language versions)
- ⑤ Output version

### 4.8.2 Fixed, non-alterable output versions

This signal converter is available with various output combinations.

- The grey boxes in the tables denote unassigned or unused connection terminals.
- In the table, only the final digits of the CG no. are depicted.
- Terminals D- and A- are connected for active pulse/frequency output (no galvanic isolation anymore).
- Available are an active or passive pulse/frequency output, or the active or passive status/limit output. It's not possible to use both at the same time!

CG no.	Connection terminals						
	S	D-	D	D+	A-	A	A+
1 0 0 R 0 0	①	P <sub>p</sub> / S <sub>p</sub> passive			I <sub>p</sub> + HART® passive ②		
		connected to A-	P <sub>a</sub> active		connected to D-	I <sub>a</sub> + HART® active ②	
		P <sub>p</sub> / S <sub>p</sub> passive			I <sub>a</sub> + HART® active ②		

Table 4-3: Basic outputs (I/Os)

- ① Shielding
- ② Function changed by reconnecting

CG no.	Connection terminals			
	B-	B	B+	S
R 0 0	Sign. A (D0-)	Common	Sign. B (D1+)	Shielding

Table 4-4: Modbus (I/O) (option)

I <sub>a</sub>	I <sub>p</sub>	Current output active or passive
P <sub>a</sub>	P <sub>p</sub>	Pulse/frequency output active or passive
S <sub>a</sub>	S <sub>p</sub>	Status output/limit switch active or passive

Table 4-5: Description of used abbreviations

## 4.9 Description of the inputs and outputs

### 4.9.1 Current output

**INFORMATION!**

*Depending on the version, the outputs must be connected passively or actively!*

- All outputs are electrically isolated from each other and from all other circuits.
- All operating data and functions can be adjusted.
- Passive mode: external power  $V_{\text{ext}} \leq 32 \text{ VDC}$  at  $I \leq 22 \text{ mA}$
- Active mode: load impedance  $R_L \leq 750 \Omega$  at  $I \leq 22 \text{ mA}$
- Self-monitoring: interruption or load impedance too high in the current output loop
- Error message possible via status output, error indication on LC display.
- Current value error detection can be adjusted.
- Automatic range conversion via threshold. The setting range for the threshold is between 5 and 80% of  $Q_{100\%}$ ,  $\pm 0...5\%$  hysteresis (corresponding ratio from smaller to larger range of 1:20 to 1:1.25).  
Signaling of the active range possible via a status output (adjustable).
- Forward / reverse flow measurement (F/R mode) is possible.

**INFORMATION!**

*For further information refer to Connection diagrams of outputs on page 37 and refer to Technical data on page 74.*

### 4.9.2 Pulse output and frequency output

**INFORMATION!**

*Depending on the version, the outputs must be connected passively or actively!*

- All outputs are electrically isolated from each other and from all other circuits.
- All operating data and functions can be adjusted.
- Passive mode:  
External power supply required:  $V_{\text{ext}} \leq 32 \text{ VDC}$   
 $I \leq 100 \text{ mA}$  at  $f \leq 10 \text{ kHz}$  (over range up to  $f_{\text{max}} \leq 12 \text{ kHz}$ )
- Active mode:  
Use of the internal power supply:  $V_{\text{nom}} = 20 \text{ VDC}$   
 $I_{\text{Peak}} < 100 \text{ mA}$   
 $I_{\text{Average}} \leq 10 \text{ mA}$  at  $f \leq 10 \text{ kHz}$  (over range up to  $f_{\text{max}} \leq 10 \text{ kHz}$ )
- Scaling:  
Frequency output: in pulses per time unit (e.g. 1000 pulses/s at  $Q_{100\%}$ );  
Pulse output: quantity per pulse.
- Pulse width:  
symmetric (pulse duty factor 1:1, independent of output frequency)  
automatic (with fixed pulse width, duty factor approx. 1:1 at  $Q_{100\%}$ ) or  
fixed (pulse width adjustable as required from 0.05 ms...2 s)
- Forward / reverse flow measurement (F/R mode) is possible.
- The pulse and frequency output can also be used as a status output / limit switch.

**INFORMATION!**

*For further information refer to Connection diagrams of outputs on page 37 and refer to Technical data on page 74.*

### 4.9.3 Status output and limit switch

**INFORMATION!**

*Depending on the version, the outputs must be connected passively or actively!*

- The status outputs / limit switches are electrically isolated from each other and from all other circuits.
- The output stages of the status outputs/limit switches during simple active or passive operation behave like relay contacts and can be connected with any polarity.
- All operating data and functions can be adjusted.
- Passive mode:  
External power supply required:  $V_{\text{ext}} \leq 32 \text{ VDC}$ ;  $I \leq 100 \text{ mA}$
- Active mode:  
Use of the internal power supply:  $V_{\text{nom}} = 20 \text{ VDC}$ ;  $I \leq 20 \text{ mA}$
- For information on the adjustable operating states refer to *Function tables* on page 52.

**INFORMATION!**

*For further information refer to Connection diagrams of outputs on page 37 and refer to Technical data on page 74.*

## 4.10 Electrical connection of the outputs



### INFORMATION!

Assembly materials and tools are not part of the delivery. Use the assembly materials and tools in compliance with the applicable occupational health and safety directives.

### 4.10.1 Electrical connection of the outputs



### DANGER!

All work on the electrical connections may only be carried out with the power disconnected. Take note of the voltage data on the nameplate!

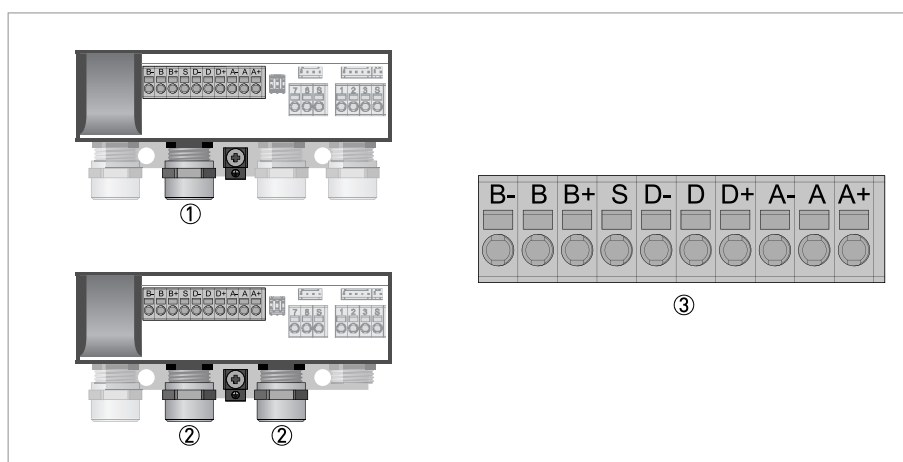

Figure 4-13: Electrical connection of the outputs

- ① Cable entry, remote version
- ② Cable entry, compact version (right cable entry is optional)
- ③ Terminal block for the connection of outputs



- Open the housing cover
- Push the prepared cables through the cable entries and connect the necessary conductors.
- Connect the shield.
- Close the housing cover.



### INFORMATION!

Ensure that the housing gasket is properly fitted, clean and undamaged.

### 4.10.2 Laying electrical cables correctly

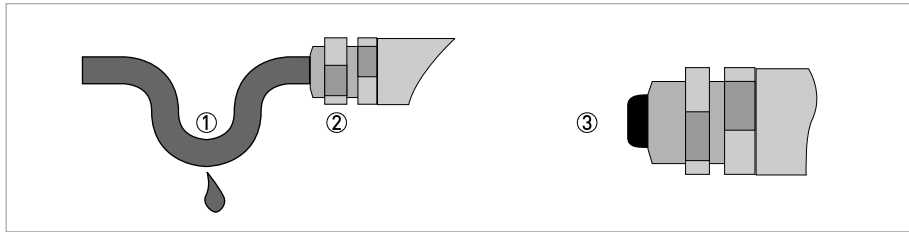

Figure 4-14: Protect housing from dust and water



- ① For compact versions with nearly horizontally-oriented cable entries, lay the necessary electric cables with a drip loop as shown in the illustration.
- ② Tighten the screw connection of the cable entry securely.
- ③ Seal cable entries that are not needed with a plug.

## 4.11 Connection diagrams of outputs

### 4.11.1 Important notes



**INFORMATION!**

*Depending on the version, the outputs must be connected passively or actively!*

- All groups are electrically isolated from each other and from all other output circuits.
- Passive mode: An external power supply is necessary to operate (activation) the subsequent devices ( $V_{\text{ext}}$ ).
- Active mode: The signal converter supplies the power for operation (activation) of the subsequent devices, observe max. operating data.
- Terminals that are not used should not have any conductive connection to other electrically conductive parts.

$I_a$	$I_p$	Current output active or passive
$P_a$	$P_p$	Pulse/frequency output active or passive
$S_a$	$S_p$	Status output/limit switch active or passive

Table 4-6: Description of used abbreviations

4.11.2 Description of the electrical symbols



	<p>mA meter 0...20 mA or 4...20 mA and other <math>R_L</math> is the internal resistance of the measuring point including the cable resistance</p>
	<p>DC voltage source (<math>V_{ext}</math>), external power supply, any connection polarity</p>
	<p>DC voltage source (<math>V_{ext}</math>), observe connection polarity according to connection diagrams</p>
	<p>Internal DC voltage source</p>
	<p>Controlled internal current source in the device</p>
	<p>Electronic or electromagnetic counter At frequencies above 100 Hz, shielded cables must be used to connect the counters. <math>R_i</math> Internal resistance of the counter</p>
	<p>Button, N/O contact or similar</p>

Table 4-7: Description of the electrical symbols

### 4.11.3 Basic and Modbus outputs

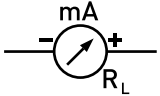
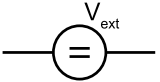
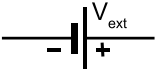
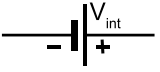
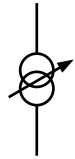
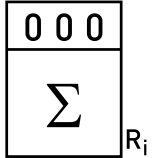

**CAUTION!**  
Observe connection polarity.



**INFORMATION!**  
For further information refer to *Description of the inputs and outputs* on page 33 and refer to *HART connection* on page 43.

#### Current output active (HART®)

- $V_{\text{int, nom}} = 20 \text{ VDC}$
- $I \leq 22 \text{ mA}$
- $R_L \leq 750 \Omega$
- HART® at connection terminals A

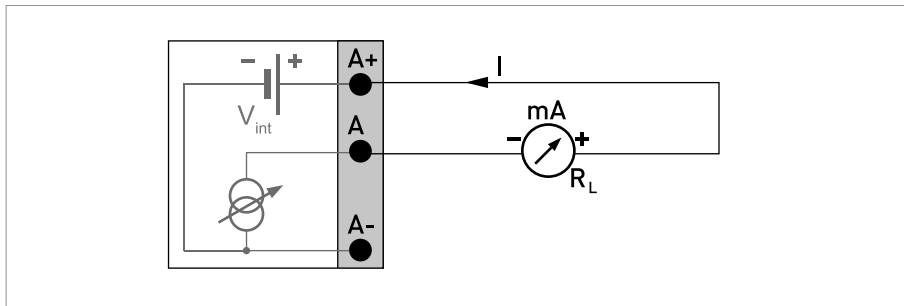

Figure 4-15: Current output active  $I_a$

#### Current output passive (HART®)

- $V_{\text{ext}} \leq 32 \text{ VDC}$
- $I \leq 22 \text{ mA}$
- $V_0 \leq 2 \text{ V}$  at  $I = 22 \text{ mA}$
- $R_{L, \text{max}} = (V_{\text{ext}} - V_0) / I_{\text{max}}$
- HART® at connection terminals A

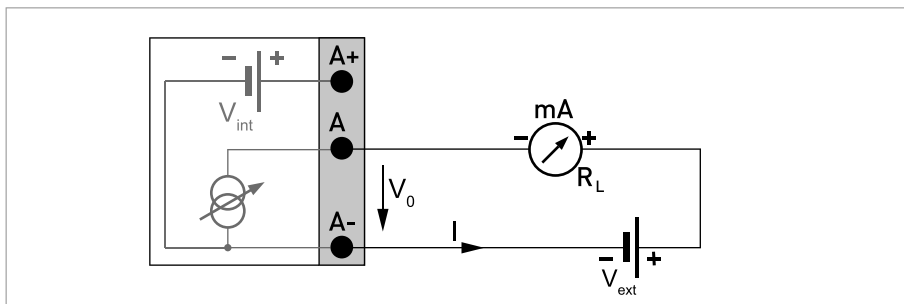

Figure 4-16: Current output passive  $I_p$

**INFORMATION!**

- For frequencies above 100 Hz, shielded cables are to be used in order to reduce effects from electrical interferences (EMC).
- Shielding takes place at the electrical connection (S) of the output terminal block.

**INFORMATION!**

- Independent of connection polarity.
- The output is open if the signal converter is not powered.

**Pulse/frequency output passive**

- $V_{\text{ext}} \leq 32 \text{ VDC}$
- $f_{\text{max}}$  in the operating menu set to  $f_{\text{max}} \leq 100 \text{ Hz}$ :  
 $I \leq 100 \text{ mA}$   
 $R_L \leq 47 \text{ k}\Omega$   
 closed:  
 $V_0 \leq 0.2 \text{ V}$  at  $I = 10 \text{ mA}$   
 $V_0 \leq 2 \text{ V}$  at  $I = 100 \text{ mA}$   
 open:  
 $I \leq 0.05 \text{ mA}$  at  $V_{\text{ext}} = 32 \text{ V}$
- $f_{\text{max}}$  in operating menu set to  $100 \text{ Hz} < f_{\text{max}} \leq 10 \text{ kHz}$ :  
 (over range up to  $f_{\text{max}} \leq 12 \text{ kHz}$ )  
 $I \leq 20 \text{ mA}$   
 $R_L \leq 10 \text{ k}\Omega$  for  $f \leq 1 \text{ kHz}$   
 $R_L \leq 1 \text{ k}\Omega$  for  $f \leq 10 \text{ kHz}$   
 closed:  
 $V_0 \leq 1.5 \text{ V}$  at  $I = 1 \text{ mA}$   
 $V_0 \leq 2.5 \text{ V}$  at  $I = 10 \text{ mA}$   
 $V_0 \leq 5 \text{ V}$  at  $I = 20 \text{ mA}$   
 open:  
 $I \leq 0.05 \text{ mA}$  at  $V_{\text{ext}} = 32 \text{ V}$   
 Use shielded cables!
- The minimum load impedance  $R_{L, \text{min}}$  is calculated as follows:  

$$R_{L, \text{min}} = (V_{\text{ext}} - V_0) / I_{\text{max}}$$
- Can also be set as status output; for the electrical connection refer to status output connection diagram.

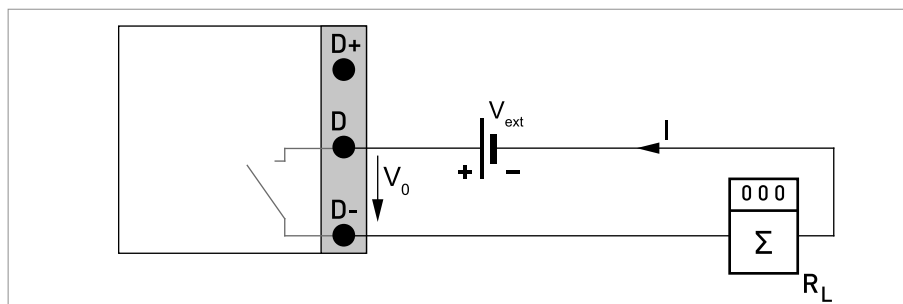
Figure 4-17: Pulse/frequency output passive  $P_p$

**INFORMATION!**

- The active output is galvanically coupled with the current output.
- This output is intended to drive mechanical or electronic counters directly.

**Pulse/frequency output active**

- $V_{\text{int, nom}} \leq 20 \text{ V}$
- $R_V = 1 \text{ k}\Omega$
- $C = 1000 \text{ }\mu\text{F}$
- **High current mechanical counter**  
 $f_{\text{max}} \leq 1 \text{ Hz}$
- **Low current mechanical counter**  
 $I \leq 20 \text{ mA}$   
 $R_L \leq 10 \text{ k}\Omega$  for  $f \leq 1 \text{ kHz}$   
 $R_L \leq 1 \text{ k}\Omega$  for  $f \leq 10 \text{ kHz}$   
closed:  
 $V_0 \geq 12.5 \text{ V}$  at  $I = 10 \text{ mA}$   
open:  
 $I \leq 0.05 \text{ mA}$  at  $V_{\text{nom}} = 20 \text{ V}$

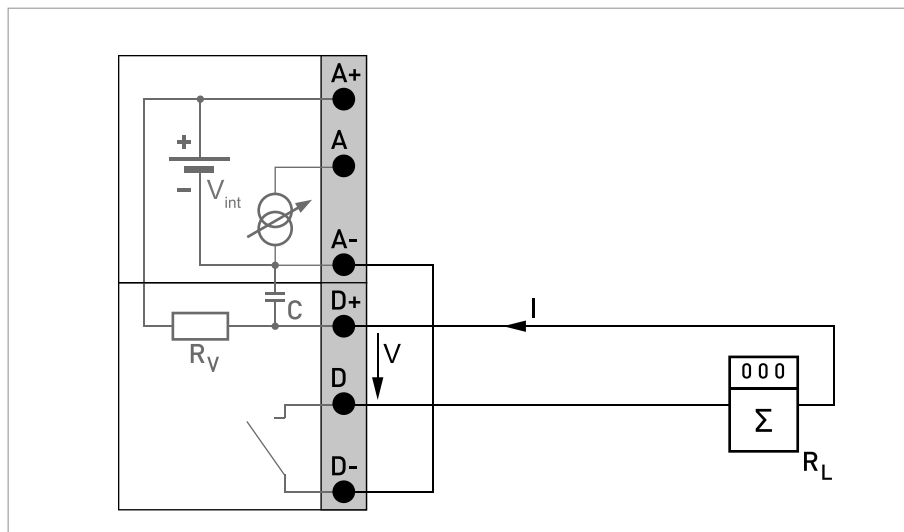
Figure 4-18: Pulse/frequency output active  $P_a$

**INFORMATION!**

- Independent of connection polarity.
- The output is open if the signal converter is not powered.

**Status output / limit switch passive**

- $V_{\text{ext}} \leq 32 \text{ VDC}$
- $I \leq 100 \text{ mA}$
- $R_L = 47 \text{ k}\Omega$
- closed:
  - $V_0 \leq 0.2 \text{ V}$  at  $I = 10 \text{ mA}$
  - $V_0 \leq 2 \text{ V}$  at  $I = 100 \text{ mA}$
- open:
  - $I \leq 0.05 \text{ mA}$  at  $V_{\text{ext}} = 32 \text{ V}$

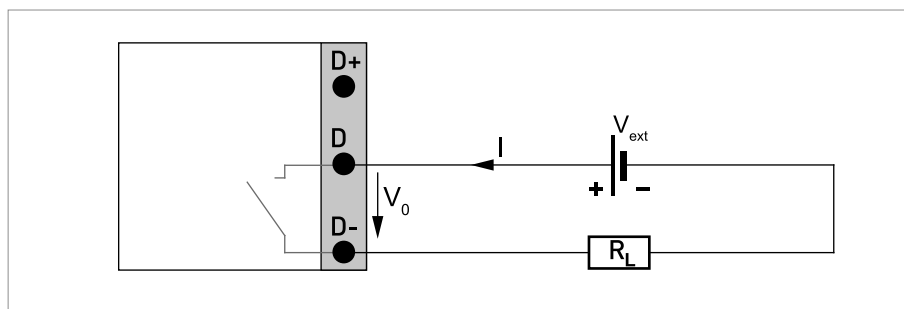

Figure 4-19: Status output / limit switch passive  $S_p$

#### 4.11.4 HART connection



##### INFORMATION!

The current output always has HART<sup>®</sup> capability and is connected at connection terminals A+ / A- / A.

All HART<sup>®</sup> connections (point-to-point and multi-drop operation) both work actively and passively.

##### Example for active HART<sup>®</sup> connection (point-to-point)

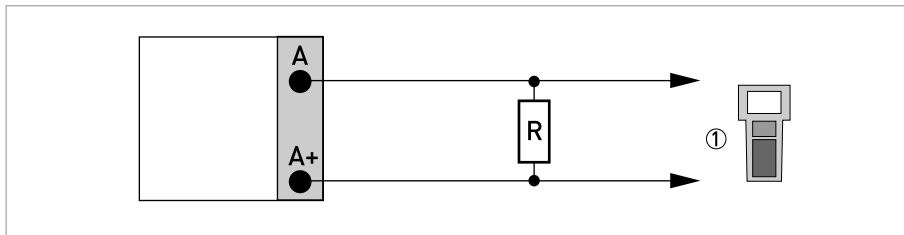

Figure 4-20: HART<sup>®</sup> connection active ( $I_a$ )

① HART<sup>®</sup> communicator

The parallel resistance to the HART<sup>®</sup> communicator must be  $R \geq 230 \Omega$ .

##### Example for passive HART<sup>®</sup> connection (multi-drop mode)

- $I: I_{0\%} \geq 4 \text{ mA}$
- Multi-drop mode  $I: I_{\text{fix}} \geq 4 \text{ mA} = I_{0\%}$
- $V_{\text{ext}} \leq 32 \text{ VDC}$
- $R \geq 230 \Omega$

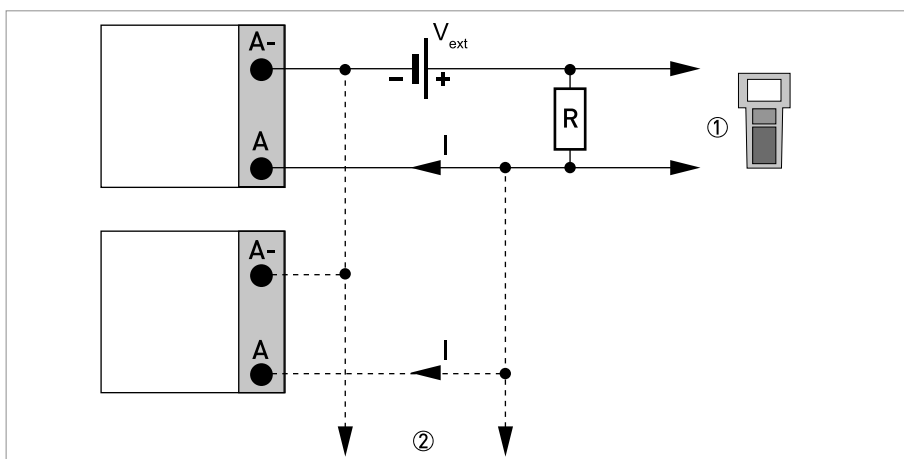

Figure 4-21: HART<sup>®</sup> connection passive ( $I_p$ )

① HART<sup>®</sup> communicator

② Other devices with HART<sup>®</sup> capability

## 5.1 Switching on the power

Before connecting to power, please check that the system has been correctly installed. This includes:

- The device must be mounted in compliance with the regulations.
- Remove the magnet pencil and keep it on a save place (is only valid for the display version).
- The power connections must have been made in compliance with the regulations.
- The electrical terminal compartments must be secured and the covers have been screwed on.
- Check that the electrical operating data of the power supply are correct.



- Switching on the power.

## 5.2 Starting the signal converter

The measuring device, consisting of the flow sensor and the signal converter, is supplied ready for operation. All operating data have been set at the factory in accordance with your order specifications.

When the power is switched on, a self test is carried out. After that the device immediately begins measuring, and the current values are displayed.

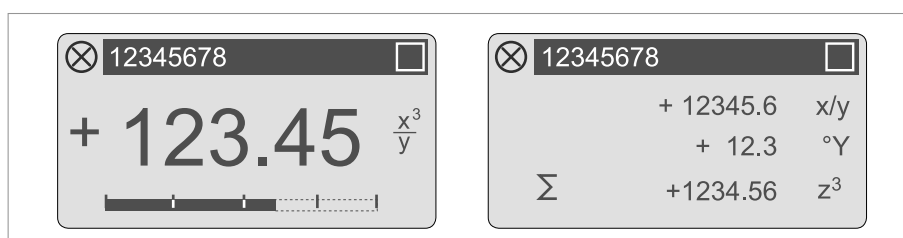

Figure 5-1: Displays in measuring mode (examples for 2 or 3 measured values)  
x, y and z denote the units of the measured values displayed

It is possible to change between the two measured value windows, the trend display and the list with the status messages by pressing the keys  $\uparrow$  and  $\downarrow$ . For information about possible status messages, their meaning and cause refer to *Status messages and diagnostic information* on page 66.

## 6.1 Safety instructions for the use of the magnet pencil

To operate the signal converter when the housing is closed, 4 magnetic keys are available. They are activated by a magnet pencil.



### **WARNING!**

*The magnet pencils can be dangerous for people with cardiac pacemakers or other metal implants. Make sure that these people do not use the magnet pencil or meet minimum clearances! Observe the relevant national and local regulations and requirements!*

## 6.2 Display and operating elements

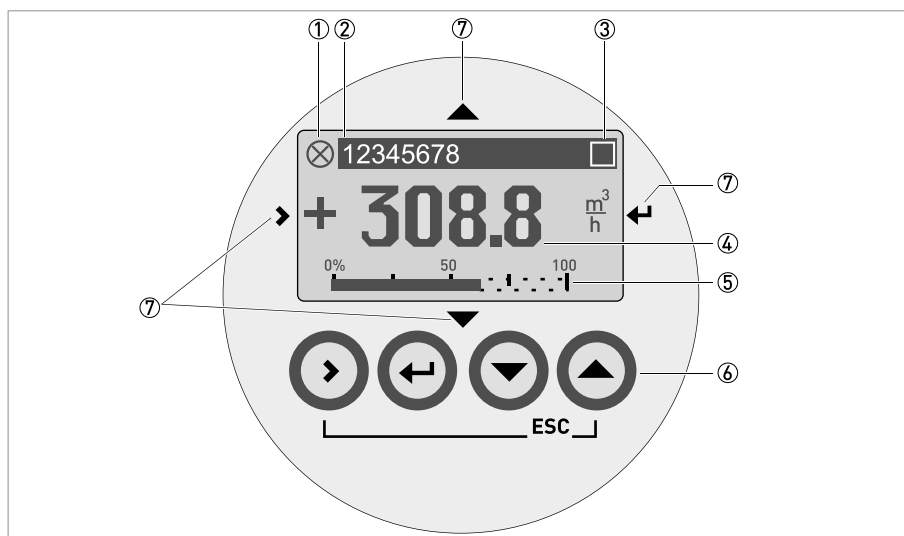

Figure 6-1: Display and operating elements (Example: flow indication with 2 measuring values)

- ① Indicates a possible status message in the status list (see table below for status icons)
- ② Tag number (is only indicated if this number was entered previously by the operator)
- ③ Indicates when a key has been pressed
- ④ 1st measured variable in large representation
- ⑤ Bargraph indication
- ⑥ Push buttons for operation with open housing (see table below for function and representation in text)
- ⑦ Magnet keys for operation with closed housing (see table below for function and representation in text)



### **INFORMATION!**

- *After 5 minutes of inactivity, there is an automatic return to measuring mode. Previously changed data is not saved.*

The device user interface provides several display modes. In measuring mode the following display pages are available:



Display page in measuring mode	Screen
1st measuring page	
2nd measuring page	
Graphic page	
Status page	

Table 6-1: Indication of display pages

The following display modes are available:

Display modes and functionality	> key	← key	↓ or ↑ key	Esc (> + ↑) key
<b>Measuring mode</b> Display of measurement values	Press key for 2.5 s  At measuring pages or graphic page enters device menu for configuration.  At status page enters menu for status messages and details	Reset display	Switch between display pages: 1st and 2nd measuring page, graphic page and status page	-
<b>Menu mode</b> Navigation through device menu or active status messages	Access to displayed menu, then 1st submenu is displayed	Either return to menu level above or to measuring mode but prompt whether the data should be saved	Select menu item	-
<b>Parameter and data mode</b> Changing parameter values or starting function	For numerical values, move cursor (highlighted in <b>black</b> ) one position to the right	Return to menu mode	Use cursor (highlighted in <b>black</b> ) to change number, unit, property and to move the decimal point	Return to menu mode without acceptance of data

Table 6-2: Description of display modes and operating keys

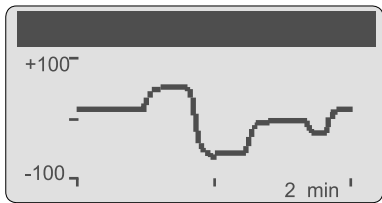
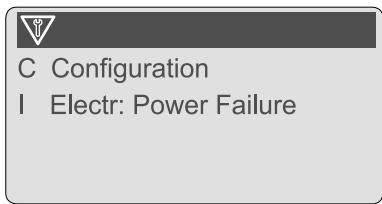
The following status levels with the related symbols are available:





Symbol	Symbol background colour	Letter	Status signal	Description and consequence
	white	<b>F</b> (bold)	Error in device	No measurement possible.
	blue	F	Application error	No measurement possible due to process/application conditions. The device is still OK.
	blue	S	Out of specification	Measurements are available but are no longer sufficiently accurate and should be checked.
	blue	M	Maintenance required	Measurements are still accurate but this could soon change
	blue	C	Checks in progress	A test function is active. The displayed or transferred measured value does not correspond to the actual measured value.
-	-	I	Information	No direct influence on the measurements.
-	-	-	No message	-

Table 6-3: Description of the icons for the status level

For further information refer to *Status messages and diagnostic information* on page 66.

## 6.2.1 Display in measuring mode with 2 or 3 measured values

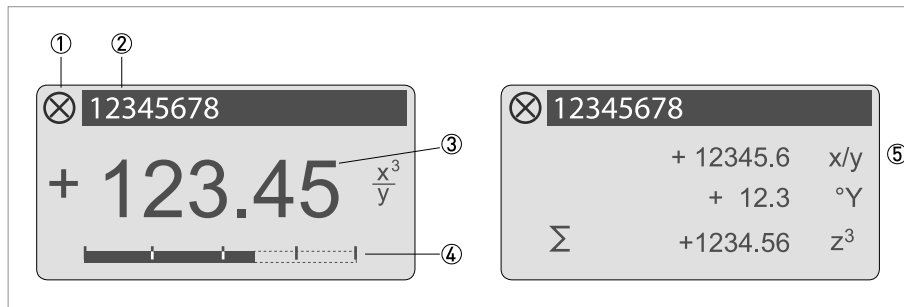

Figure 6-2: Example for display in measuring mode with 2 or 3 measured values

- ① Indicates a possible status message in the status page
- ② Tag (is only indicated if this string was entered previously by the operator)
- ③ 1st measured variable in large representation
- ④ Bargraph indication
- ⑤ Depiction with 3 measured values

## 6.2.2 Display for selection of submenu and functions in menu mode

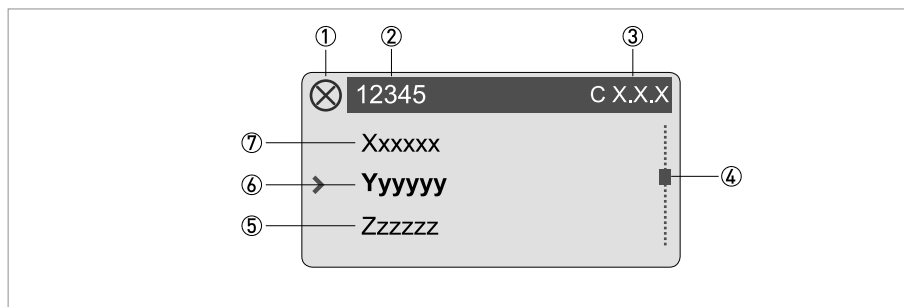

Figure 6-3: Display for selection of submenu and functions in menu mode

- ① Indicates a possible status message in the status page
- ② Menu, submenu or function name
- ③ Number relating to ⑥
- ④ Indicates position within menu, submenu or function list
- ⑤ Next menu(s), submenu or function  
[\_\_\_ signals in this line the end of the list]
- ⑥ Current menu(s), submenu or function
- ⑦ Previous menu(s), submenu or function  
[\_\_\_ signals in this line the beginning of the list]

### 6.2.3 Display when setting a parameter in parameter and data mode

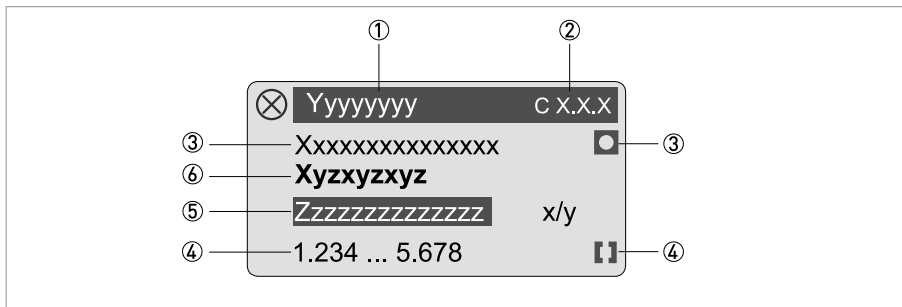

Figure 6-4: Display when setting a parameter in parameter and data mode

- ① Current menu(s), submenu or function
- ② Number related to this parameter
- ③ Factory setting of this parameter
- ④ Permissible value range for this parameter
- ⑤ Currently set value, unit or function (when selected, appears with white text, black background); this is where the parameter value is changed
- ⑥ Name of this parameter

### 6.2.4 Display for selection of submenu and functions with preview

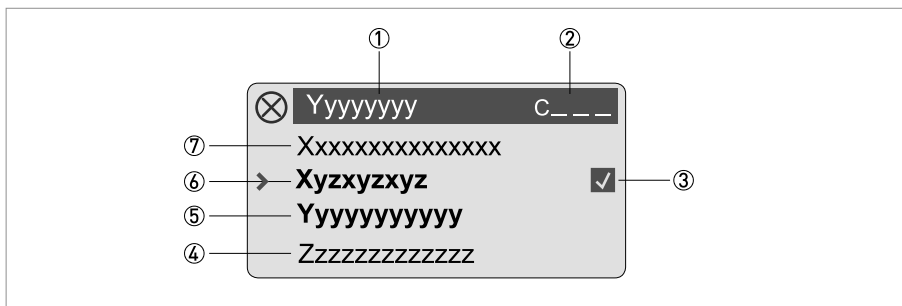

Figure 6-5: Display for selection of submenu and functions with preview

- ① Current menu(s), submenu or function
- ② Number related to ④
- ③ Denotes a changed parameter (simple check of changed data when browsing through lists)
- ④ Next parameter
- ⑤ Current value of parameter from ⑥
- ⑥ Current parameter (for selection press key >; then see previous chapter)
- ⑦ Previous parameter

### 6.3 Menu structure



**INFORMATION!**

- The menu structure for the standard device is described.
- Special functions for Modbus are described in detail in the corresponding supplementary instructions.
- Note the key function within and between the columns.

Measuring mode	Select menu	↓ ↑	Select menu and/or submenu	↓ ↑	Select function and set data	↓ ↑ >
←	Press > 2.5 s					
	A quick setup	> ←	A1 language	> ←	-	> ←
			A2 HART	> ←	A2.1 Tag	
			A3 RS 485 / Modbus	> ←	A3.1 Tag A3.2 slave address	
			A4 reset?	> ←	A4.1 reset errors A4.2 counter 1 ① A4.3 counter 2 ①	
			A5 analogue outputs	> ←	A5.1 range A5.2 time constant A5.3 low flow cutoff	
			A6 digital outputs	> ←	A6.1 max. pulse rate A6.2 pulse value unit A6.3 value p. pulse	
			A7 process input	> ←	A7.1 device serial no. A7.2 zero calibration ① A7.3 size ① A7.4 GKL ① A7.5 field frequency ① A7.6 flow direction ①	
←	B test	> ←	B1 simulation	> ←	For details about the submenus refer to <i>Menu "B test"</i> on page 54.	> ←
		B2 actual values				
		B3 information				
		↓↑		↓↑		↓↑>

Table 6-4: Menu structure "A quick setup" and "B test"

① Available if "quick setup" activated

Measuring mode		Select menu	Select menu and/or submenu	Select function and set data
		↓ ↑	↓ ↑	↓ ↑ >
←	Press > 2.5 s			
	C setup	> ←	C1 process input	> ←
			C1.1 calibration	
			C1.2 filter	
			C1.3 self test	
			C1.4 information	
			C1.5 simulation	
←		> ←	C2 I/O (input/output)	> ←
			C2.1 hardware	
			C2.1 - ①	
			C2.1 current output A ①	
			C2.5 - ①	
			C2.5 frequency out D ①	
			C2.5 pulse output D ①	
			C2.5 status output D ①	
			C2.5 limit switch D ①	
←		> ←	C3 I/O counter	> ←
			C3.1 counter 1	
			C3.2 counter 2	
←		> ←	C4 HART	> ←
			C4.1 HART (on/off)	
			C4.2 address	
			C4.3 message	
			C4.4 description	
			C4.5 HART units	
←		> ←	C6 device	> ←
			C6.1 device info	
			C6.2 display	
			C6.3 1. meas. page	
			C6.4 2. meas. page	
			C6.5 graphic page	
			C6.6 special functions	
			C6.7 units	
			C6.8 quick setup	
		↓ ↑		↓ ↑
			↓ ↑	↓ ↑ >

Table 6-5: Menu structure "C setup"

① Depending on settings in "C2.2 hardware"

## 6.4 Function tables



### INFORMATION!

- The functions for the standard device are described in the following tables.
- Special functions for Modbus are described in detail in the corresponding supplementary instructions.
- Depending on the device version, not all functions are available.

### 6.4.1 Menu "A quick setup"

Function	Setting / Description
A quick setup	

#### A1 language

A1 language	Language selection depends on the device version.
-------------	---

#### A2 HART

A2.1 Tag	Measuring point identifier (Tag no.) appears in the LC display header (up to 8 digits).
----------	---

#### A3 RS485/Modbus

A3.1 Tag	Measuring point identifier (Tag no.) appears in the LC display header (up to 16 digits). The first 8 digits are identical to the HART <sup>®</sup> measuring point (see above).
A3.2 slave address	Setting the device address at the Modbus interface.

#### A4 reset

A4.1 reset errors	Query: reset? Select: no / yes
A4.2 counter 1	Query: reset counter? Select: no / yes (available if activated in C5.9.1)
A4.3 counter 2	Query: reset counter? Select: no / yes (available if activated in C5.9.2)

#### A5 analogue outputs

A5.1 range	Measuring range for the analogue outputs (current output, frequency output and display).
A5.2 time constant	Time constant for the analogue outputs (current output, frequency output and display).
A5.3 low flow cutoff	Low flow cutoff for the analogue outputs (current output and frequency output).

#### A6 digital outputs

A6.1 max. pulse rate	Setting the maximum pulse rate.
	Limit is 120% of this pulse rate or (refer to pulse width) by pulse width when the off time is 50% of the on time.
A6.2 pulse value unit	Selection of the unit from a list, depending on the "measurement".
A6.3 value p. pulse	Setting for pulse output D (volume or mass value per pulse).
	Setting: xxx.xxx in L or kg or in the unit selected in A6.2

Function	Setting / Description
A quick setup	

### A7 process input

A7.1 device serial no.	Shows the serial number of the system (C5.1.3).
The following process input parameters are only available, if the quick access has been activated in the menu "setup / device / quick setup" (C6.8.3).	
A7.2 zero calibration	Display of actual zero calibration value.
	Query: calibrate zero? Select: break / manual / default / automatic
	For settings refer to C1.1.1.
A7.3 size	Select from size table. For details refer to C1.1.2.
A7.4 GKL	Set value according to information on nameplate; range: 0.5...20 For details refer to C1.1.3.
A7.5 field frequency	Setting as on flow sensor nameplate = line frequency x value (from the following list): 1/2; 1/4; 1/6; 1/8; 1/12; 1/18; 1/36; 1/50 For details refer to C1.1.9.
A7.6 flow direction	Define the polarity of the flow direction.
	Select: normal direction (according to the arrow on the flow sensor) / reverse direction (in the opposite direction to the arrow) For details refer to C1.2.2.

Table 6-6: Description of menu "A quick setup"

## 6.4.2 Menu "B test"

Function	Setting / Description
B test	

**B1 simulation**

B1.1 volume flow B1.1 mass flow	Depending on the selection, simulation of the volume or mass flow according to the following sequence: Select: set value / break (exit function without simulation)
	Query: start simulation? Select: no (exit function without simulation) / yes (start simulation)
B1.2 current output A	Simulation X
B1.3 pulse output D	[X stands for one of the connection terminals A or D] Sequence and settings similar to B1.2, see above!
B1.3 frequency out X	
B1.3 limit switch D	For the pulse output the set number of pulses are displayed once in a second!
B1.3 status output D	

**B2 actual values**

B2.1 operating hours	Display the actual operating hours. Exit the displayed function with the ← key.
B2.2 act. flow speed	Display the actual flow speed. Exit the displayed function with the ← key.
B2.3 electr. temperature	Display the actual electronics temperature. Exit the displayed function with the ← key.
B2.4 act. coil resistance	Display the actual resistance of the field coils.

**B3 information**

B3.1 C number	This number identifies the type of electronics; It can be found on the signal converter assembly sticker as well.
B3.2 Electronic Revision ER	Reference identification number, electronic revision and production date of the device; includes all hardware and software changes.
B3.3 device serial no.	Serial number of the system.
B3.4 electronic serial no.	Serial number of the electronics assembly.

Table 6-7: Description of menu "B test"

### 6.4.3 Menu "C setup"

Function	Setting / Description
<b>C setup - C1 process input</b>	

#### C1.1 calibration

C1.1.1 zero calibration	Display of actual zero calibration value.
	Query: calibrate zero? Select: break (return with $\leftarrow$ key) / default (factory setting) / manual (display last value, set new value, range: -1.00...+1 m/s) / automatic (shows the current value as the new zero calibration value)
C1.1.2 size	Select from size table.
C1.1.3 GKL	Set value acc. to the information on the nameplate. Range: 0.5...20
C1.1.4 measurement	Select: volume flow (default setting) / mass flow (using the fixed density, the volume flow is converted into mass flow)
C1.1.5 range	Measuring range for the analogue outputs (only used for current output, frequency output and display). Range: 0...100%
C1.1.6 density	For calculating the mass flow from the volume flow. Range: 0.1...5 kg/L
C1.1.7 target conduct.	Reference value for on-site calibration. Range: 1.000...50000 $\mu$ S/cm
C1.1.8 EF electr. factor	For calculation of the conductivity based on the electrode impedance.
	Query: calibrate EF? Select: break (return with $\leftarrow$ key) / default (with factory setting) / manual (set desired value) / automatic (determines EF according to the setting in C1.1.10)
C1.1.9 field frequency	Setting as on flow sensor nameplate = line frequency x value (from the following list): 1/2; 1/4; 1/6; 1/8; 1/12; 1/18; 1/36; 1/50
C1.1.10 select settling	Select settling (special function).
	Select: standard (fixed allocation) / manual (manual time setting for the settling time for the field current)
C1.1.11 settling time	Only available if "manual" is selected in C1.1.10. Range: 1.0...250 ms
C1.1.12 line frequency	Setting the line frequency.
	Select: 50 Hz or 60 Hz
C1.1.13 act. coil resistance	Display of the actual resistance of the field coil.

#### C1.2 filter

C1.2.1 limitation	Limitation of all flow values, before smoothing by time constant, affects all outputs.
	Settings: -xxx.x / +xxx.x m/s; condition: 1st value < 2nd value
	Range 1st value: -100.0 m/s $\leq$ value $\leq$ -0.001 m/s
	Range 2nd value: +0.001 m/s $\leq$ value $\leq$ +100 m/s
C1.2.2 flow direction	Define the polarity of the flow direction.
	Select: normal direction (according to the arrow on the flow sensor) / reverse direction (in the opposite direction to the arrow)
C1.2.3 time constant	Time constant of all flow measurements.
	xxx.x s; range: 0.0...100 s

Function	Setting / Description
<b>C setup - C1 process input</b>	
C1.2.4 pulse filter	Suppresses noise due to solids, air/gas bubbles and sudden changes in pH.
	Select: off (without pulse filter) / on (with pulse filter) / automatic (with new pulse filter)
	<b>Pulse filter "on"</b> : The change from one measurement value to the next one is limited to the value "pulse limitation" for the total time "pulse width". This filter allows a faster signal tracking for slowly changing flow values.
	<b>Pulse filter "automatic"</b> : The raw flow values are collected into a buffer, covering two times the "pulse width" values. This filter is called "median" filter. This filter allows a better suppression of pulse shaped disturbances (particles or air bubbles in very noisy environment).
C1.2.5 pulse width	Length of interference and delays to be suppressed on sudden changes in flow.
	Only available, if pulse filter (C1.2.4) is "on" or "automatic".
	xx.x s; range for "on": 0.01...10 s or for "automatic": 0.1...20 s
C1.2.6 pulse limitation	Dynamic limitation from one measured value to the next; only if pulse filter (C1.2.4) is "on".
	xx.x s; range: 0.01...100 m/s
C1.2.7 low flow cutoff	Sets low flow values to "0"; affects all outputs
	x.xxx ± x.xxx L/h; range: 0.0...10 L/h
	(1st value = switching point / 2nd value = hysteresis), condition: 2nd value ≤ 1st value

### C1.3 self test

C1.3.1 empty pipe detect.	Select: off / conductivity / cond.+empty pipe (F) (conductivity measurement S/m and empty pipe indication, error category [F] application) / cond.+empty pipe (S) (conductivity measurement S/m and empty pipe indication, error category [S] measurement out of specification) / cond. + empty pipe (I) (conductivity measurement S/m and empty pipe indication, error category [I] information)
	Flow indication "= 0" when "empty pipe"
	Activation takes place only after restart of the device (accepting the changes by leaving the menu).
C1.3.2 limit empty pipe	Only available if "empty pipe [...]" is activated in C1.3.1.
	Range: 0.0...9999 µS (set about 50% of the lowest occurring conductivity in operation). Conductivity below this value means a signal as "empty pipe".
C1.3.3 act. conductivity	Only available if "empty pipe [...]" is activated in C1.3.1.
	Actual conductivity is indicated. Activation takes place only after setting mode is exited!
C1.3.4 time constant	Only available if "empty pipe [...]" is activated in C1.3.1.
	Range: xxx.x s; 0.1...100 s
	A damping is set for "empty pipe detect."

Function	Setting / Description
<b>C setup - C1 process input</b>	

### C1.4 information

C1.4.1 liner	Shows the material of the liner.
C1.4.2 electr. material	Shows the material of the electrodes.
C1.4.3 calibration date	Shows the date on which the flow sensor was calibrated.
C1.4.4 serial no. sensor	Shows the serial number of the flow sensor.
C1.4.5 V no. sensor	Shows the order number of the flow sensor.
C1.4.6 sensor electr. info	Shows the serial number of the circuit board, the software version number and the calibration date of the circuit board.

### C1.5 simulation

C1.5.2 volume flow C1.5.2 mass flow	For sequence refer to B1.1.
--	-----------------------------

Table 6-8: Description of menu "C setup - C1 process input"

Function	Setting / Description
<b>C setup - C2 I/O (Inputs/Outputs)</b>	

### C2.1 hardware

C2.1.1 terminals A	Select: off (switched off) / current output
C2.1.2 terminals D	Select: off (switched off) / frequency output / pulse output / status output / limit switch

### C2.2 current output A

C2.2.1 range 0%...100%	Current range for the selected "measurement", e.g. 4...20 mA, corresponds to 0...100%
	xx.x...xx.x mA; range: 0.00...20 mA Condition: $0 \text{ mA} \leq 1\text{st value} \leq 2\text{nd value} \leq 20 \text{ mA}$
C2.2.2 extended range	Min. and max. limits of current values. If the current range is exceeded, the current is set to these limits.
	xx.x ... xx.x mA; range: 03.5...21.5 mA Condition: $0 \text{ mA} \leq 1\text{st value} \leq 2\text{nd value} \leq 21.5 \text{ mA}$ and out of current range
C2.2.3 error current	Specify error current.
	xx.x mA; range: 3...22 mA Condition: outside of extended range
C2.2.4 error condition	Set the error conditions.
	Select: error in device (error category [F]) / application error (error category [F]) / out of specification (error category [F] & [S])
C2.2.5 polarity	Set polarity; please note flow direction in C1.2.2!
	Select: both polarities (plus and minus values are displayed) / positive polarity (display for negative values = 0) / negative polarity (display for positive values = 0) / absolute value (always displays positive, with both negative and positive values)
C2.2.6 low flow cutoff	Sets the measurement to "0" for low values.
	x.xxx...x.xxx%; range: 0.0...20%
	(1st value = switching point / 2nd value = hysteresis); condition: $2\text{nd value} \leq 1\text{st value}$

Function	Setting / Description
<b>C setup - C2 I/O (Inputs/Outputs)</b>	
C2.2.7 time constant	Range: 000.1...100 s
C2.2.8 information	Serial number of the I/O board, software version number and production date of the circuit board.
C2.2.9 simulation	For sequence refer to "B1.2 current output A".
C2.2.10 4mA trimming	Trimming of the current at 4 mA.
	Reset to 4 mA restores the factory calibration.
	Used for HART <sup>®</sup> setting.
C2.2.11 20mA trimming	Trimming of the current at 20 mA.
	Reset to 20 mA restores the factory calibration.
	Used for HART <sup>®</sup> setting.

### C2.3 frequency out X

C2.3.1 pulse shape	Specify the pulse shape.
	Select: symmetric (about 50% on and 50% off) / automatic (constant pulse with about 50% on and 50% off at 100% pulse rate) / fixed (fixed pulse rate; for setting refer to "C2.3.3 100% pulse rate")
C2.3.2 pulse width	Only available if set to "fixed" in C2.3.1.
	Range: 0.05...2000 ms
	Note: max. setting value $T_p$ [ms] $\leq$ 500 / max. pulse rate [1/s], gives the pulse width = time where the output is activated
C2.3.3 100% pulse rate	Pulse rate for 100% of the measuring range.
	Range: 1...10000 Hz
	Limitation 100% pulse rate $\leq$ 100/s: $I_{max} \leq$ 100 mA Limitation 100% pulse rate $>$ 100/s: $I_{max} \leq$ 20 mA
C2.3.4 polarity	Set polarity; please note flow direction in C1.2.2!
	Select: both polarities (plus and minus values are displayed) / positive polarity (display for negative values = 0) / negative polarity (display for positive values = 0) / absolute value (always displays positive, with both negative and positive values)
C2.3.5 low flow cutoff	Sets the measurement to "0" for low values.
	x.xxx $\pm$ x.xxx L/h; range: 0.0...20 L/h
	(1st value = switching point / 2nd value = hysteresis), condition: 2nd value $\leq$ 1st value
C2.3.6 time constant	Range: 000.1...100 s
C2.3.7 invert signal	Select: off (activated output: switch closed) / on (activated output: switch open)
C2.3.8 information	Serial number of the I/O board, software version number and production date of the circuit board.
C2.3.9 simulation	For sequence refer to "B1.3 frequency out D".

Function	Setting / Description
<b>C setup - C2 I/O (Inputs/Outputs)</b>	

### C2.3 pulse output D

C2.3.1 pulse shape	Specify the pulse shape. Select: symmetric (about 50% on and 50% off) / automatic (constant pulse with about 50% on and 50% off at max. pulse rate) / fixed (fixed pulse rate, for setting refer to "C2.3.3 max. pulse rate")
C2.3.2 pulse width	Only available if set to "fixed" in C2.3.1. Range: 0.05...2000 ms Note: max. setting value $T_p$ [ms] $\leq$ 500 / max. pulse rate [1/s], gives the pulse width = time where the output is activated
C2.3.3 max. pulse rate	Setting the maximum pulse rate. Limit is 120% of this pulse rate.
C2.3.4 pulse value unit	Selection of the unit from a list, depending on the "measurement".
C2.3.5 value p. pulse	Set value for volume or mass per pulse. xxx.xxx, measured value
C2.3.6 polarity	Set polarity; please note flow direction in C1.2.2! Select: both polarities (plus and minus values are displayed) / positive polarity (display for negative values = 0) / negative polarity (display for positive values = 0) / absolute value (always displays positive, with both negative and positive values)
C2.3.7 invert signal	Select: off (activated output: switch closed) / on (activated output: switch open)
C2.3.8 information	Serial number of the I/O board, software version number and production date of the circuit board.
C2.3.9 simulation	For sequence refer to "B1.3 pulse output D".

### C2.3 status output D

C2.3.1 mode	Measuring conditions of the output. Select: out of specification (output set, signals status of category "error in device" or "application error" or "out of specification" refer to <i>Status messages and diagnostic information</i> on page 66) / application error (output set, signals status of the category "error in device" or "application error" refer to <i>Status messages and diagnostic information</i> on page 66) / polarity flow (polarity of the current flow) / over range flow (over range of the flow) / counter 1 preset (activates counter 1 when preset value is reached) / counter 2 preset (activates counter 2 when preset value is reached) / output A (displays the polarity at output A) / off (switched off) / empty pipe (when pipe empty, output activated) / error in device (output set, signals status of the category "error in device" refer to <i>Status messages and diagnostic information</i> on page 66)
C2.3.2 invert signal	Select: off (activated output: switch closed) / on (activated output: switch open)
C2.3.3 information	Serial number of the I/O board, software version number and production date of the circuit board.
C2.3.4 simulation	For sequence refer to "B1.3 status output D".

Function	Setting / Description
<b>C setup - C2 I/O (Inputs/Outputs)</b>	

### C2.3 limit switch D

C2.3.1 threshold	Switching level, set threshold with hysteresis
C2.3.2 polarity	Set polarity; please note flow direction in C1.2.2! Select: both polarities (plus and minus values are displayed) / positive polarity (display for negative values = 0) / negative polarity (display for positive values = 0) / absolute value (always displays positive, with both negative and positive values)
C2.3.3 time constant	Range: 000.1...100 s
C2.3.4 invert signal	Select: off (activated output: switch closed) / on (activated output: switch open)
C2.3.5 information	Serial number of the I/O board, software version number and production date of the circuit board.
C2.3.6 simulation	For sequence refer to "B1.3 limit switch D".

Table 6-9: Description of menu "C setup - C2 I/O (Inputs/Outputs)"

Function	Setting / Description
<b>C setup - C3 I/O counter</b>	
C3.1 counter 1	Set function of counter.
C3.2 counter 2	_ stands for 1, 2 (= counter 1, 2)
C3._1 funct. of counter	Select: sum counter (counts positive + negative values) / + counter (counts only the positive values) / - counter (counts only the negative values) / off (counter is switched off)
C3._2 preset value	If this value is reached, positive or negative, a signal is generated that can be used for a status output at which "preset counter X" has to be set. Preset value (max. 8 digits) x.xxxxx in selected unit; refer to C5.7.10 and C5.7.13
C3._3 reset counter	Query: reset counter? Select: no / yes (available if activated in C5.9.1)
C3._4 set counter	Set counter _ to the desired value. Select: break (exit function) / set value (opens the editor to make the entry) Query: set counter? Select: no (exit function without setting the value) / yes (sets the counter and exits the function)
C3._5 stop counter	Counter _ stops and holds the current value. Select: no (exits the function without stopping the counter) / yes (stop the counter and exits the function)
C3._5 start counter	Start counter _ after that counter is stopped. Select: no (exits the function without starting the counter) / yes (starts the counter and exits the function)
C3._7 information	Serial number of the I/O board, software version number and production date of the circuit board.

Table 6-10: Description of menu "C setup - C3 I/O counter"

Function	Setting / Description
<b>C setup - C4 HART</b>	
The dynamic variables are fixed to the following values: PV: flow (volume flow or mass flow, depending on the selection of "measurement" in C1.1.4) SV: counter 1 TV: counter 2 4V: conductivity (default) or operating time	
C4.1 HART	HART® communication is activated or deactivated. Select: on (HART® is activated; default setting) / off (HART® is disabled)
C4.2 address	Setting the address for multi-drop operation. If "address 0" is selected, the current output is in normal operation. For all other addresses, the current at the output is set to the 0% value.
C4.3 message	Entry of individual text.
C4.4 description	Entry of individual text.
C4.5 HART units	Unit change of dynamic variables in the display. Select: break (return with ↵ key) / HART® display (copies the settings for the display units to the settings for the DVs) / load defaults (resets the DVs to the factory defaults)
C4.6 Set 4V (or QV)	Unit is HART® dynamic variable. Select: conductivity / coil temperature / mass flow / volume flow / flow speed / operating hours / counter 2 / counter 1 / diagnosis value

Table 6-11: Description of menu "C setup - C4 HART"

Function	Setting / Description
<b>C setup - C6 device</b>	

**C6.1 device info**

C6.1.1 Tag	Settable characters (max. 8 digits): A...Z; a...z; 0...9; / - , .
C6.1.2 C number	CG number, cannot be changed; describes the signal converter version.
C6.1.3 device serial no.	Serial number of the system; cannot be changed.
C6.1.4 electronic serial no.	Serial number of the electronic assembly; cannot be changed.
C6.1.5 SW.REV.MS	Serial number of the circuit board, version number of the main software, production date of the circuit board.
C6.1.6 Electronic Revision ER	Reference identification number, electronic revision and production date of the device; includes all hardware and software changes.

**C6.2 display**

C6.2.1 language	Language selection depends on the device version.
C6.2.2 contrast	Adjust display contrast for extreme temperatures. Setting: -9...0...+9 This change takes place immediately, not just when setting mode is exited!
C6.2.3 default display	Specification of the default display page that is returned to after a short delay period. Select: none (current page is always active) / 1. meas. page (shows this page) / 2. meas. page (shows this page) / status page (shows only status messages) / graphic page (trend of the 1st measurement)

Function	Setting / Description
<b>C setup - C6 device</b>	
C6.2.4 magnet keys	For activating or deactivating the magnet keys.
	Select: on (magnet keys are enabled) / off (magnet keys are disabled)
C6.2.5 status indication LED	This function is only available for device versions without display.
	Status display via a green or red LED (in case of device error, application error or out of specification).
SW.REV.UIS	Serial number of the circuit board, version number of user interface software, production date of the circuit board.

### C6.3 1. meas. page

C6.3.1 format 1.line	Number of decimal places specified (depending on available space) for "1.line" of "1. meas. page".
C6.3.2 measurement 2.line	Selects the value to be shown on the second line of the first measurement screen.
	Select: conductivity / bargraph (default)

### C6.4 2. meas. page

C6.4.1 format 1.line	Number of decimal places specified (depending on available space) for "1.line" of "2. meas. page".
C6.4.2 format 2.line	Number of decimal places specified (depending on available space) for "2.line" of "2. meas. page".
C6.4.3 format 3.line	Number of decimal places specified (depending on available space) for "3.line" of "2. meas. page".

### C6.5 graphic page

C6.5.1 select range	Select: manual (set range in C6.5.2) / automatic (automatic depiction based on the measured values)
	Reset only after parameter change or after switching off and on.
C6.5.2 range	Set the scaling for the Y axis. Only available if "manual" is set in C6.5.1.
	±xxx...±xxx%; range: -100...+100%
	(1st value = lower limit / 2nd value = upper limit), condition: 1st value ≤ 2nd value
C6.5.3 time scale	Set the time scaling for the X axis, trend curve
	xxx min; range: 0...100 min

### C6.6 special function

C6.6.1 reset errors	Query: reset?
	Select: no / yes
C6.6.2 save settings	Save current settings.
	Select: break (exit function without saving) / backup 1 (saves the settings in the backup 1 storage place) / backup 2 (saves the settings in the backup 2 storage place)
	Query: go on with copy? (cannot be undone)
	Select: no (exit function without saving) / yes (copy current settings to storage backup 1 or backup 2)

Function	Setting / Description
<b>C setup - C6 device</b>	
C6.6.3 load settings	Load saved settings.  Select: break (exit function without loading) / factory settings (reload factory settings) / backup 1 (loads the settings from the backup 1 storage place) / backup 2 (loads the settings from the backup 2 storage place) / load sensor data (restore factory setting of the values for the flow sensor. Display and I/O settings are retained!)
	Query: go on with copy? (cannot be undone)  Select: no (exit function without saving) / yes (load data from the selected storage place)
C6.6.4 password quick set	Password required to change data in the menu "quick setup".  0000 (= to this menu without password)  xxxx (password required); range 4 digits: 0001...9999
C6.6.5 password setup	Password required to change data in the menu "setup".  0000 (= to this menu without password)  xxxx (password required); range 4 digits: 0001...9999

### C6.7 units

C6.7.1 volume flow	m <sup>3</sup> /h; m <sup>3</sup> /min; m <sup>3</sup> /s; L/h; L/min; L/s (L = litres); cf/h; cf/min; cf/s; gal/h; gal/min; gal/s; IG/h; IG/min; IG/s; free unit (set factor and text in the next two functions, sequence see below)
C6.7.2 Text free unit	For text to be specified refer to <i>Set free units</i> on page 64:
C6.7.3 [m <sup>3</sup> /s]*factor	Specification of the conversion factor, based on m <sup>3</sup> /s:  xxx.xxx refer to <i>Set free units</i> on page 64
C6.7.4 mass flow	kg/s; kg/min; kg/h; t/min; t/h; g/s; g/min; g/h; lb/s; lb/min; lb/h; ST/min; ST/h (ST = Short Ton); LT/h (LT = Long Ton); free unit (set factor and text in the next two functions, sequence see below)
C6.7.5 Text free unit	For text to be specified refer to <i>Set free units</i> on page 64:
C6.7.6 [kg/s]*factor	Specification of the conversion factor, based on kg/s:  xxx.xxx refer to <i>Set free units</i> on page 64
C6.7.7 volume	m <sup>3</sup> ; L; hL; mL; gal; IG; in <sup>3</sup> ; cf; yd <sup>3</sup> ; free unit (set factor and text in the next two functions, sequence see below)
C6.7.8 Text free unit	For text to be specified refer to <i>Set free units</i> on page 64:
C6.7.9 [m <sup>3</sup> ]*factor	Specification of the conversion factor, based on m <sup>3</sup> :  xxx.xxx refer to <i>Set free units</i> on page 64
C6.7.10 mass	kg; t; mg; g; lb; ST; LT; oz; free unit (set factor and text in the next two functions, sequence see below)
C6.7.11 Text free unit	For text to be specified refer to <i>Set free units</i> on page 64:
C6.7.12 [kg]*factor	Specification of the conversion factor, based on kg:  xxx.xxx refer to <i>Set free units</i> on page 64
C6.7.13 flow speed	m/s; ft/s
C6.7.14 density	kg/L; kg/m <sup>3</sup> ; lb/cf; lb/gal; free unit (set factor and text in the next two functions, sequence see below)
C6.7.15 Text free unit	For text to be specified refer to <i>Set free units</i> on page 64:
C6.7.16 [kg/m <sup>3</sup> ]*factor	Specification of the conversion factor, based on kg/m <sup>3</sup> :  xxx.xxx refer to <i>Set free units</i> on page 64

Function	Setting / Description
<b>C setup - C6 device</b>	
C6.7.17 conductivity	S/m; $\mu$ S/cm

### C6.8 quick setup

Activate quick access in menu "quick setup"; default setting: "quick setup" is active (yes) Select: yes (activated) / no (not activated)	
C6.8.1 reset counter 1	Reset counter 1 in menu "quick setup". Select: yes (activated) / no (not activated)
C6.8.2 reset counter 2	Reset counter 2 in menu "quick setup". Select: yes (activated) / no (not activated)
C6.8.3 process input	Activate quick access to the important process input parameters. Select: yes (activated) / no (not activated)

Table 6-12: Description of menu "C setup - C6 device"

### 6.4.4 Set free units

Free units	Sequences to set texts and factors
<b>Texts</b>	
Volume flow, mass flow, mass, volume, density and pressure	3 digits before and after the slash xxx/xxx (max. 6 characters plus a "/")
Permissible characters	A...Z; a...z; 0...9; / - + , . *; @ \$ % ~ () [] _
<b>Conversion factors</b>	
Desired unit	= base unit * conversion factor
Conversion factor	Max. 9 digits
Shift decimal point	↑ to the left and ↓ to the right

Table 6-13: Sequences to set texts and factors

## 6.5 Description of functions

### 6.5.1 Reset counter in the menu "quick setup"



**INFORMATION!**

*It may be necessary to activate resetting of the counter in the menu "quick setup".*

Key	Function	Description
>	A quick setup	Press and hold for 2.5 s, then release the key.
>	A1 language	-
3 x ↓	A4 reset	-
>	A4.1 reset errors	-
↓	A4.2 counter 1	Select desired counter.
↓	A4.3 counter 2	
>	Query: reset counter? Select: no	-
↓ or ↑	Query: reset counter? Select: yes	-
↵	A4.2 counter 1 or A4.3 counter 2	Counter has been reset.
3 x ↵	Measuring mode	-

Table 6-14: Reset counter in the menu "quick setup"

### 6.5.2 Deleting error messages in the menu "quick setup"



**INFORMATION!**

*For the detailed list of the possible error messages refer to Status messages and diagnostic information on page 66.*

Key	Function	Description
>	A quick setup	Press and hold for 2.5 s, then release the key.
>	A1 language	-
3 x ↓	A4 reset	-
>	A4.1 reset errors	-
>	Query: reset errors? Select: no	-
↓ or ↑	Query: reset errors? Select: yes	-
↵	A4.1 reset errors	Error has been reset.
3 x ↵	Measuring mode	-

Table 6-15: Deleting error messages in the menu "quick setup"

### 6.5.3 Conductivity measurement

The included conductivity measurement is meant to detect empty pipes only.

The measurement is done by measurement of the real part of the electrode impedance.

The measurement is developed for a range from 1 to 1000  $\mu\text{S}/\text{cm}$  at electrode factor  $EF = 3 \text{ mm}$ .

The measurement is limited to about 10000  $\mu\text{S}/\text{cm}$  at  $EF = 3 \text{ mm}$  on the high limit. The limitation to the low limit is depending on the cable length between the electronics and the flow sensor.

Cable length between electronics and flow sensor	Field frequency setting (C1.1.13)	Low conductivity limit
Compact version	1/4 and above	0.3 $\mu\text{S}/\text{cm}$
	1/2	1 $\mu\text{S}/\text{cm}$
Remote version: 10 m / 32.8 ft signal cable	1/4 and above	3 $\mu\text{S}/\text{cm}$
	1/2	10 $\mu\text{S}/\text{cm}$
Remote version: 100 m / 328 ft signal cable	1/4 and above	30 $\mu\text{S}/\text{cm}$
	1/2	100 $\mu\text{S}/\text{cm}$

Table 6-16: Low conductivity limit

## 6.6 Status messages and diagnostic information

The diagnostic messages are displayed in accordance with NAMUR standard NE 107.

Each status message (= status signal) has a specific symbol, determined by NAMUR, which is displayed with the message. The length of each message is limited to one line.

The symbols are shown in the top left corner of the display on every screen.





Symbol	Symbol background colour	Letter	Status signal	Description and consequence
	white	<b>F</b> (bold)	Error in device	No measurement possible.
	blue	F	Application error	No measurement possible due to process/application conditions. The device is still OK.
	blue	S	Out of specification	Measurements are available but are no longer sufficiently accurate and should be checked.
	blue	M	Maintenance required	Measurements are still accurate but this could soon change
	blue	C	Checks in progress	A test function is active. The displayed or transferred measured value does not correspond to the actual measured value.
-	-	I	Information	No direct influence on the measurements.
-	-	-	No message	-

Table 6-17: Description of the icons for the status level

Messages on the display	Description	Actions
Status: F _ _ _ _ _	Operational fault in device, mA output $\leq$ 3.6 mA or set fault current (depending on the seriousness of the fault), status output open, pulse / frequency output: no pulses	Repair necessary.
F error in device	Error or failure of device. Parameter or hardware error. No measurement possible.	Group message, when one of the following or some other severe error occurs.
F IO 1	Error, operational fault in IO 1. Parameter or hardware error. No measurement possible.	Load settings (C4.6.3) (backup 1, backup 2 or factory settings). If status message still does not disappear, replace electronic unit.
F parameter	Error, operational fault of data manager, electronic unit, parameter or hardware error. Parameters no longer usable.	
F configuration	Invalid configuration: display software, bus parameter or main software do not match existing configuration.	If device configuration unchanged: defective, replace electronic unit.
F display	Error, operational fault in display. Parameter or hardware error. No measurement possible.	Defective, replace electronic unit.
F sensor electronic	Error, operational fault in flow sensor electronics. Parameter or hardware error. No measurement possible.	Defective, replace electronic unit.
F sensor global	Data error in the global data of the flow sensor electronic equipment.	Load settings (C5.6.3) (backup 1, backup 2 or factory settings). If status message still does not disappear, replace electronic unit.
F sensor local	Data error in the local data of the flow sensor electronic equipment.	Defective, replace electronic unit.
F field current local	Data error in the local data of the field current supply.	Defective, replace electronic unit.
F current output A	Error, operational fault in current output. Parameter or hardware error. No measurement possible.	Defective, replace electronic unit.
F current output C		
F software user interface	Fault revealed by CRC check of operation software.	Replace electronic unit.
F hardware settings	The set hardware parameters do not match the identified hardware. A dialogue appears in the display.	Answer queries in dialogue mode, follow directions. Defective, replace electronic unit.
F hardware detection	Existing hardware cannot be identified.	Defective, replace electronic unit.
F RAM/ROM error IO1	A RAM or ROM error is detected during the CRC check.	Defective, replace electronic unit.

Table 6-18: Operational faults in device

Messages on the display	Description	Actions
Status: F _ _ _ _ _	<b>Application-dependent fault, device OK, but measured values affected.</b>	<b>Application test or operator action necessary.</b>
F application error	Application-dependent fault, but device is OK.	Group message, when errors as described below or other application errors occur.
F empty pipe	1 or 2 measuring electrodes are not in contact with the medium; measured value is set to zero. No measurement possible.	Measuring pipe not filled; function dependent on C1.3.2. Check installation. Or electrodes completely insulated e.g. by oil film. Clean!
F flow exceeding limit	Measuring range exceeded, filter setting limits measured values. No message if empty pipe.  If this limit occurs sporadically in processes with air pockets, solid contents or low conductivity, then either the limit has to be increased or a pulse filter used so as to quell the error messages and also reduce the measurement errors.	Limitation C1.2.1, increase values.
F field frequency too high	Field frequency is not reaching steady state, a measured flow value is still being supplied but may have errors. Measured values are still supplied, but they are always too low. No message if coil broken or bridged.	If "C1.1.14 settling time" is set to "manual", increase value in C1.1.15. If "standard" is set, set the field frequency in C1.1.13 according to the signal converter nameplate.
F DC offset	ADC over-ranged by DC offsets. No measurement can be performed, the flow is set to zero. No message if empty pipe.	For remote signal converter, check the connection of the signal cable.
F open circuit A	Load on current output A too high, effective current too low.	Current not correct, mA output cable has open circuit or load too high. Check cable, reduce load (set < 750 Ω).
F open circuit C		
F over range A	The current or the corresponding measured value is limited by a filter setting.	Check with "C2.1 hardware" or the sticker in the terminal compartment, which output is connected to the terminal. If current output: extend "C2.x.6 range" and "C2.x.8 limitation". If frequency output: extend values in "C2.x.5" and "C2.x.7".
F over range C		
F over range D	The pulse rate or the corresponding measured value is limited by a filter setting. Or the demanded pulse rate is too high.	
F active settings	Error during the CRC check of the active settings.	Upload backup 1 or backup 2 settings, check and adjust if necessary.
F factory settings	Error during the CRC check of the factory settings.	-
F backup 1 settings	Error during the CRC check of the backup 1 or 2 settings.	Save active settings in backup 1 or 2.
F backup 2 settings		

Table 6-19: Application error

Messages on the display	Description	Actions
Status: S _ _ _ _ _	Out of specification, measurement continues, accuracy possibly less.	Maintenance required.
S uncertain measurement	Device maintenance necessary; measured values only conditionally usable.	Group message, when errors as described below or other influences occur.
S empty pipe	1 or 2 measuring electrodes are not in contact with the medium; measured value is set to zero. No measurement possible.	Measuring pipe not filled, function dependent on C1.3.2. Check installation. Or electrodes completely insulated e.g. by oil film. Clean!
S field coil broken	Field coil resistance too high.	Check field coil connections to the electronic module (for remote versions: field current cable) for open circuit / short circuit
S field coil bridged	Field coil resistance too low.	
S electronic temperature	Upper limit for the permissible electronic temperature has been exceeded.	Ambient temperature too high, direct solar radiation or, for C version, process temperature too high.
S overflow counter 1	This is counter 1. Counter has overrun and started again at zero.	-
S overflow counter 2	This is counter 2. Counter has overrun and started again at zero.	-
S backplane invalid	The data record on the backplane is invalid. The CRC check has revealed a fault.	No data can be loaded from the backplane when replacing electronics. Save the data to the backplane again (Service).
S field frequency too high	The field frequency is set so high that the field current cannot settle. The measured values displayed are too low.	Set field frequency lower; refer to C1.1.13.

Table 6-20: Measurements out of specification

Messages on the display	Description	Actions
Status: C _ _ _ _ _	Output values partially simulated or fixed	Maintenance required.
C checks in progress	Test mode of the device. Measured values are possibly simulated values or values with fixed settings.	Message depending on the situation via HART® or FDT.
C test sensor	Test function of the flow sensor electronics is active.	-

Table 6-21: Simulation of the measured values

Messages on the display	Description	Actions
Status: I _ _ _ _ _	Information (current measurement OK)	
I counter 1 stopped	This is counter 1. The counter has stopped.	If counter to continue counting, activate "yes" in "C2.y.9 start counter".
I counter 2 stopped	This is counter 2. The counter has stopped.	
I power fail	The device was not in operation for an unknown period of time, because the power was switched off. This message is for information only.	Temporary power failure. Counters did not run during it.
I over range display 1	1st line on page 1 (2) of display limited by filter setting.	Menu display C4.3 and/or C4.4, select 1st or 2nd meas. page and increase values in "C4.z.3 range" and/or "C4.z.4 limitation".
I over range display 2		
I over range conductivity	The limits for the conductivity measurement have been exceeded (> 10000 $\mu\text{S}/\text{cm}$ ) or are lower than permitted (< 0.1 $\mu\text{S}/\text{cm}$ ).	If the flow sensor has been properly connected and filled with medium, this does not affect the flow measurement. The conductivity measured values cannot be used.
I backplane sensor	The data on the backplane are not usable because they have been generated with an incompatible version.	-
I backplane settings	The global settings on the backplane are not usable because they have been generated with an incompatible version.	-
I backplane difference	The data on the backplane differ from the data in the display. If the data are usable, a dialogue is indicated in the display.	-
I conductivity off	Conductivity measurement switched off.	Changing of settings in C1.3.1.
I empty pipe	1 or 2 measuring electrodes are not in contact with the medium; measured value is set to zero. No measurement possible.	Measuring pipe not filled, function dependent on C1.3.2. Check installation. Or electrodes completely insulated e.g. by oil film. Clean!
I diagnosis channel off	Diagnosis value switched off.	Changing of settings in C1.3.17.

Table 6-22: Information

## 7.1 Spare parts availability

The manufacturer adheres to the basic principle that functionally adequate spare parts for each device or each important accessory part will be kept available for a period of 3 years after delivery of the last production run for the device.

This regulation only applies to spare parts which are subject to wear and tear under normal operating conditions.

## 7.2 Availability of services

The manufacturer offers a range of services to support the customer after expiration of the warranty. These include repair, maintenance, technical support and training.



### **INFORMATION!**

*For more precise information, please contact your local sales office.*

## 7.3 Returning the device to the manufacturer

### 7.3.1 General information

This device has been carefully manufactured and tested. If installed and operated in accordance with these operating instructions, it will rarely present any problems.



### **WARNING!**

*Should you nevertheless need to return a device for inspection or repair, please pay strict attention to the following points:*

- *Due to statutory regulations on environmental protection and safeguarding the health and safety of the personnel, the manufacturer may only handle, test and repair returned devices that have been in contact with products without risk to personnel and environment.*
- *This means that the manufacturer can only service this device if it is accompanied by the following certificate (see next section) confirming that the device is safe to handle.*



### **WARNING!**

*If the device has been operated with toxic, caustic, radioactive, flammable or water-endangering products, you are kindly requested:*

- *to check and ensure, if necessary by rinsing or neutralising, that all cavities are free from such dangerous substances,*
- *to enclose a certificate with the device confirming that it is safe to handle and stating the product used.*

### 7.3.2 Form (for copying) to accompany a returned device



**CAUTION!**

*To avoid any risk for our service personnel, this form has to be accessible from outside of the packaging with the returned device.*

Company:		Address:	
Department:		Name:	
Telephone number:		Email address:	
Fax number:			
Manufacturer order number or serial number:			
The device has been operated with the following medium:			
This medium is:	<input type="checkbox"/>	radioactive	
	<input type="checkbox"/>	water-hazardous	
	<input type="checkbox"/>	toxic	
	<input type="checkbox"/>	caustic	
	<input type="checkbox"/>	flammable	
	<input type="checkbox"/>	We checked that all cavities in the device are free from such substances.	
	<input type="checkbox"/>	We have flushed out and neutralized all cavities in the device.	
We hereby confirm that there is no risk to persons or the environment caused by any residual media contained in this device when it is returned.			
Date:		Signature:	
Stamp:			

## 7.4 Disposal



**LEGAL NOTICE!**

*Disposal must be carried out in accordance with legislation applicable in your country.*

**Separate collection of WEEE (Waste Electrical and Electronic Equipment):**



According to the directive 2012/19/EU or UK Regulation 2013 No. 3113, the monitoring and control instruments marked with the WEEE symbol and reaching their end-of-life **must not be disposed of with other waste.**

The user must dispose of the WEEE to a designated collection point for the recycling of WEEE or send them back to our local organisation or authorised representative.

## 8.1 Measuring principle

An electrically conductive fluid flows inside an electrically insulated pipe through a magnetic field. This magnetic field is generated by a current, flowing through a pair of field coils.

Inside of the fluid, a voltage  $U$  is generated:

$$U = v * k * B * D$$

in which:

$v$  = mean flow velocity

$k$  = factor correcting for geometry

$B$  = magnetic field strength

$D$  = inner diameter of flowmeter

The signal voltage  $U$  is picked off by electrodes and is proportional to the mean flow velocity  $v$  and thus the flow rate  $Q$ . A is used to amplify the signal voltage, filter it and convert it into signals for totalizing, recording and output processing.

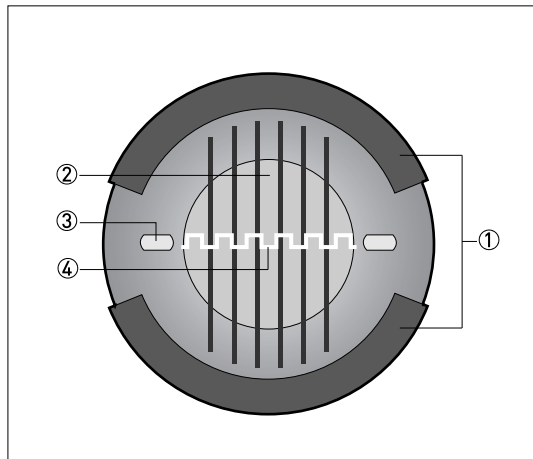

Figure 8-1: Measuring principle

- ① Field coils
- ② Magnetic field
- ③ Electrodes
- ④ Induced voltage (proportional to flow velocity)

## 8.2 Technical data



### INFORMATION!

- The following data is provided for general applications. If you require data that is more relevant to your specific application, please contact us or your local sales office.
- Additional information (certificates, special tools, software,...) and complete product documentation can be downloaded free of charge from the website (Downloadcenter).

### Measuring system

Measuring principle	Faraday's law of induction
Application range	Continuous measurement of current volume flow, flow velocity, conductivity, mass flow (at constant density), coil temperature of the flow sensor

### Design

Modular construction	The measuring system consists of a flow sensor and a signal converter.
<b>Flow sensor</b>	
OPTIFLUX 1000	DN10...150 / 3/8...6"
OPTIFLUX 2000	DN25...1200 / 1...48"
OPTIFLUX 4000	DN10...1200 / 3/8...48"
OPTIFLUX 5000	Flange: DN15...300 / 1/2...12" Sandwich: DN2.5...100 / 1/10...4"
OPTIFLUX 6000	DN10...150 / 3/8...6"
WATERFLUX 3000	DN25...600 / 1...24"
<b>Signal converter</b>	
Compact version (C)	IFC 050 C
Remote version (W)	IFC 050 W
<b>Options</b>	
Outputs	Current output (including HART®), pulse output, frequency output, status output and/or limit switch
	Note: It's not possible to use the pulse/frequency output with the status output at the same time!
Counter	2 internal counters with a max. of 10 counter places (e.g. for counting volume and/or mass units)
Verification	Integrated verification, diagnostic functions: measuring device, empty pipe detection, stabilisation
Communication interfaces	HART®
	Modbus

<b>Display and user interface</b>	
Graphic display	LC display, backlit white
	Size: 128 x 64 pixels, corresponds to 59 x 31 mm = 2.32" x 1.22"
	Ambient temperatures below -25°C / -13°F may affect the readability of the display.
Operating elements	4 push buttons for operating the signal converter when the housing is open.
	4 magnet keys for operating the signal converter when the housing is closed.
Remote control	Only generic and not device-specific DDs and DTMs available!
	PACTware™ (including Device Type Manager (DTM))
	HART® Hand Held Communicator from Emerson Process
	AMS® from Emerson Process
	PDM® from Siemens
All DTMs and drivers are available free of charge from the manufacturer's website.	
<b>Display functions</b>	
Operating menu	Setting the parameters using 2 measuring pages, 1 status page, 1 graphic page (measured values and graphics are freely adjustable)
Language display texts (as language package)	Standard: English, French, German, Dutch, Portuguese, Swedish, Spanish, Italian
	Eastern Europe: English, Slovenian, Czech, Hungarian
	Northern Europe: English, Danish, Polish, Finnish, Norwegian
	Southern Europe: English, Turkish
	China: English, German, Chinese
Russia: English, German, Russian	
Units	Metric, British and US units selectable as required from lists for volume / mass flow and counting, flow velocity, electrical conductivity, temperature

### Measuring accuracy

Max. measuring accuracy	<b>Standard:</b> ±0.5% of the measured value ± 1 mm/s
	<b>Option (optimised accuracy with extended calibration):</b> ±0.25% of the measured value ± 1.5 mm/s
	For detailed information and accuracy curves refer to <i>Measuring accuracy</i> on page 86.
	Special calibrations are available on request.
	Current output electronics: ±10 µA; ±100 ppm/°C (typically: ±30 ppm/°C)
Repeatability	±0.1%

### Operating conditions

<b>Temperature</b>	
Process temperature	Refer to the technical data of the flow sensor.
Ambient temperature	Depending on the version and combination of outputs.
	It is advised to protect the signal converter from external heat sources such as direct sunlight as higher temperatures reduce the life cycle of all electronic components.
	-40...+65°C / -40...+149°F
	Ambient temperatures below -25°C / -13°F may affect the readability of the display.
Storage temperature	-40...+70°C / -40...+158°F
<b>Pressure</b>	
Medium	Refer to the technical data of the flow sensor.
Ambient pressure	Atmosphere: altitude up to 2000 m / 6561.7 ft above sea level
<b>Chemical properties</b>	
Electrical conductivity	All media except for water: $\geq 5 \mu\text{S/cm}$ (also refer to the technical data of the flow sensor)
	Water: $\geq 20 \mu\text{S/cm}$
Type of measurement	Electrical conductive liquids
Solid content (volume)	$\leq 10\%$
Gas content (volume)	$\leq 3\%$
Flow rate	For detailed information, refer to chapter "Flow tables".
<b>Other conditions</b>	
Ingress protection	IP66/67, NEMA 4/4X

### Installation conditions

Installation	For detailed information, refer to chapter "Installation".
Inlet / outlet sections	Refer to the technical data of the flow sensor.
Dimensions and weight	For detailed information refer to chapter "Dimensions and weight".

### Materials

Signal converter housing	Aluminum with a polyester topcoat
Flow sensor	For housing materials, process connections, liners, grounding electrodes and gaskets, refer to the technical data of the flow sensor.

### Electrical connection

General	Electrical connection is carried out in conformity with the VDE 0100 directive "Regulations for electrical power installations with line voltages up to 1000 V" or equivalent national specifications.
Power supply	100...230 VAC (-15% / +10%), 50/60 Hz; 240 VAC + 5% is included in the tolerance range.
	24 VDC (-30% / +30%)
Power consumption	AC: 15 VA
	DC: 5.6 W
Signal cable	Only necessary for remote versions.
	<b>DS 300 (type A)</b> Max. length: 600 m / 1968 ft (depending on electrical conductivity and flow sensor version)
Cable entries	Standard: M20 x 1.5 (8...12 mm)
	Option: 1/2 NPT, PF 1/2

### Outputs

General	All outputs are electrically isolated from each other and from all other circuits.
	All operating data and output values can be adjusted.
Description of abbreviations	$V_{\text{ext}}$ = external voltage; $R_L$ = load + resistance; $V_0$ = terminal voltage; $I_{\text{nom}}$ = nominal current

<b>Current output</b>	
Output data	Flow
Settings	<b>Without HART®</b>
	Q = 0%: 0...20 mA; Q = 100%: 10...21.5 mA
	Error identification: 20...22 mA
	<b>With HART®</b>
	Q = 0%: 4...20 mA; Q = 100%: 10...21.5 mA
	Error identification: 3...22 mA
<b>Operating data</b>	<b>Basic I/Os</b>
Active	Observe connection polarity.
	$V_{int, nom} = 20 \text{ VDC}$
	$I \leq 22 \text{ mA}$
	$R_L \leq 750 \Omega$
	HART® at terminals A
Passive	Observe connection polarity.
	$V_{ext} \leq 32 \text{ VDC}$
	$I \leq 22 \text{ mA}$
	$V_0 \leq 2 \text{ V at } I = 22 \text{ mA}$
	$R_{L, max} = (V_{ext} - V_0) / I_{max}$
	HART® at terminals A
<b>HART®</b>	
Description	HART® protocol via active and passive current output
	HART® version: 5
	Universal Common Practice HART® parameter: completely supported
Load	$\geq 230 \Omega$ at HART® test point; Note maximum load for current output!
Multi-Drop mode	Yes, current output = 4 mA
	Multi-Drop address adjustable in operation menu 1...15

<b>Pulse output or frequency output</b>	
Output data	Flow
Function	Can be set as a pulse output or frequency output
Pulse rate/frequency	0.01...10000 pulses/s or Hz
Settings	Pulses per volume or mass unit or max. frequency for 100% flow
	Pulse width: adjustable as automatic, symmetric or fixed (0.05...2000 ms)
<b>Operating data</b>	<b>Basic I/Os + Modbus</b>
Active	This output is intended to drive mechanical or electronic counters directly.
	$V_{\text{int, nom}} \leq 20 \text{ V}$ $R_V = 1 \text{ k}\Omega$ $C = 1000 \mu\text{F}$
	<b>High current mechanical counter</b> $f_{\text{max}} \leq 1 \text{ Hz}$
	<b>Low current mechanical counter</b> $I \leq 20 \text{ mA}$ $R_L \leq 10 \text{ k}\Omega$ for $f \leq 1 \text{ kHz}$ $R_L \leq 1 \text{ k}\Omega$ for $f \leq 10 \text{ kHz}$ closed: $V_0 \geq 12.5 \text{ V}$ at $I = 10 \text{ mA}$ open: $I \leq 0.05 \text{ mA}$ at $V_{\text{nom}} = 20 \text{ V}$
Passive	Independent of connection polarity.
	$V_{\text{ext}} \leq 32 \text{ VDC}$
	$f_{\text{max}}$ in operating menu set to $f_{\text{max}} \leq 100 \text{ Hz}$ : $I \leq 100 \text{ mA}$ open: $I \leq 0.05 \text{ mA}$ at $V_{\text{ext}} = 32 \text{ VDC}$ closed: $V_{0, \text{max}} = 0.2 \text{ V}$ at $I \leq 10 \text{ mA}$ $V_{0, \text{max}} = 2 \text{ V}$ at $I \leq 100 \text{ mA}$
	$f_{\text{max}}$ in operating menu set to $100 \text{ Hz} < f_{\text{max}} \leq 10 \text{ kHz}$ : $I \leq 20 \text{ mA}$ open: $I \leq 0.05 \text{ mA}$ at $V_{\text{ext}} = 32 \text{ VDC}$ closed: $V_{0, \text{max}} = 1.5 \text{ V}$ at $I \leq 1 \text{ mA}$ $V_{0, \text{max}} = 2.5 \text{ V}$ at $I \leq 10 \text{ mA}$ $V_{0, \text{max}} = 5.0 \text{ V}$ at $I \leq 20 \text{ mA}$

<b>Low flow cut off</b>	
Function	Switching point and hysteresis separately adjustable for each output, counter and the display
Switching point	Set in increments of 0.1%.
	0...20% (current output, frequency output) or 0...±9.999 m/s (pulse output)
Hysteresis	Set in increments of 0.1%.
	0...5% (current output, frequency output) or 0...5 m/s (pulse output)
<b>Time constant</b>	
Function	The time constant corresponds to the elapsed time until 67% of the end value has been reached according to a step function.
Settings	Set in increments of 0.1 seconds.
	0...100 seconds
<b>Status output / limit switch</b>	
Function and settings	Adjustable as automatic measuring range conversion, display of flow direction, counter overflow, error, switching point or empty pipe detection
	Valve control with activated dosing function
	Status and/or control: ON or OFF
<b>Operating data</b>	
Passive	<b>Basic I/Os + Modbus</b>
	Independent of connection polarity. $V_{ext} \leq 32 \text{ VDC}$ $I \leq 100 \text{ mA}$ open: $I \leq 0.05 \text{ mA}$ at $V_{ext} = 32 \text{ VDC}$ closed: $V_0 = 0.2 \text{ V}$ at $I \leq 10 \text{ mA}$ $V_0 = 2 \text{ V}$ at $I \leq 100 \text{ mA}$
<b>Modbus</b>	
Description	Modbus RTU, Master / Slave, RS485
Address range	1...247
Broadcast	Supported with function code 16
Supported Baud rate	1200, 2400, 3600, 4800, 9600, 19200, 38400, 57600, 115200 Baud

### Approvals and certificates

Declaration of conformity	This device fulfils the statutory requirements of the relevant directives. The manufacturer certifies successful testing of the product by applying the conformity mark on the device.
	For more information on the directives, standards and the approved certifications, please refer to the declaration of conformity supplied with the device or downloadable from the manufacturer's website.
<b>Marine certificate</b>	
EU RO MR Type Approval	Certificate mutually recognized by: ABS, BV, CCS, CRS, DNG-GL, IRS, KR, ClassNK, PRS, RINA, RS
	For certificate and details refer to the manufacturer website.
<b>Other standards and approvals</b>	
Vibration resistance	Tested according to IEC 60068-2-64
NAMUR	NE 21, NE 43, NE 53

### 8.3 Dimensions and weight

#### 8.3.1 Housing

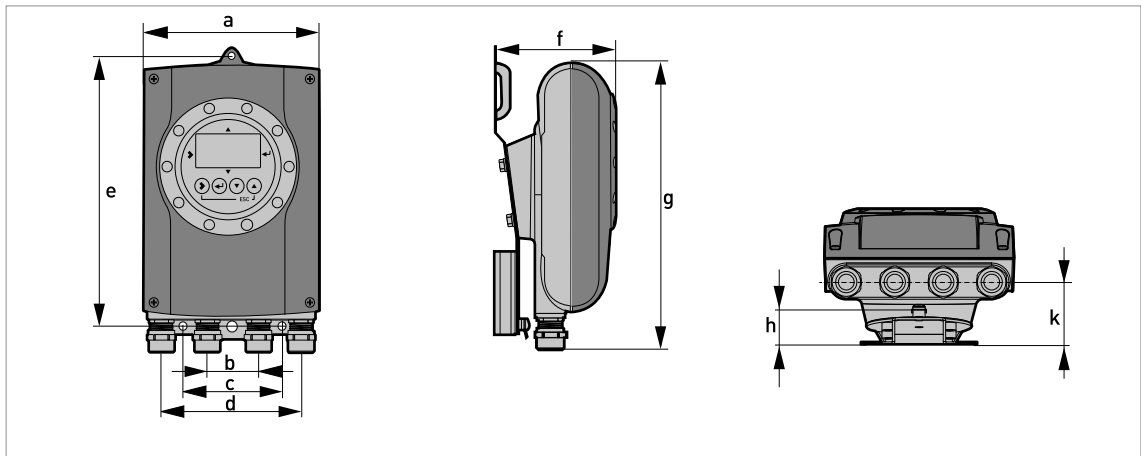

Figure 8-2: Dimensions of wall version

	Dimensions [mm]									Weight [kg]
	a	b	c	d	e	f	g	h	k	
Version with & without display	157	40	80	120	248	111.7	260	28.4	51.3	1.9

Table 8-1: Dimensions and weight in mm and kg

	Dimensions [inch]									Weight [lb]
	a	b	c	d	e	f	g	h	k	
Version with & without display	6.18	1.57	3.15	4.72	9.76	4.39	10.24	1.12	2.02	4.2

Table 8-2: Dimensions and weight in inch and lb

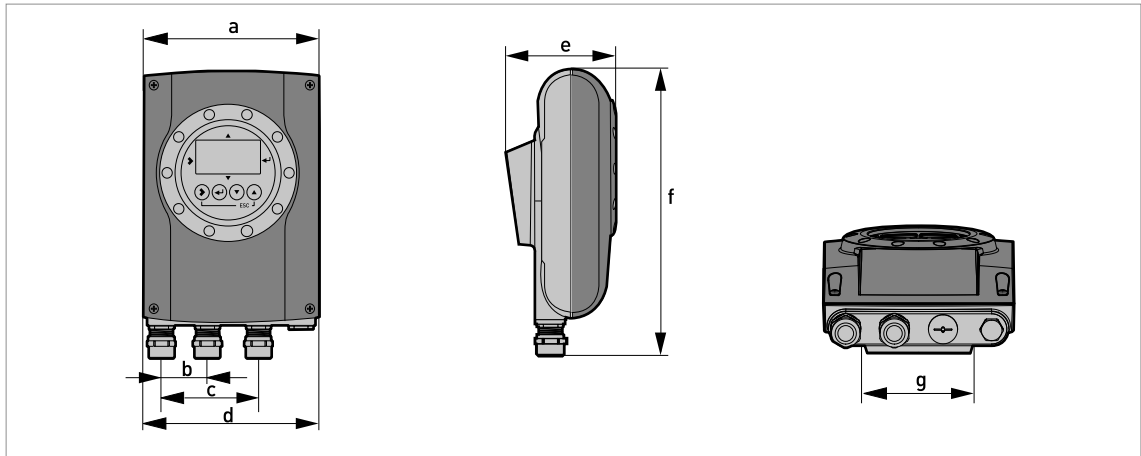

Figure 8-3: Dimensions of compact version

	Dimensions [mm]							Weight [kg]
	a	b	c	d	e	f	g	
Version with & without display	157	40	80	148.2	101	260	95.5	1.8

Table 8-3: Dimensions and weight in mm and kg

	Dimensions [inch]							Weight [lb]
	a	b	c	d	e	f	g	
Version with & without display	6.18	1.57	3.15	5.83	3.98	10.24	3.76	4.0

Table 8-4: Dimensions and weight in inch and lb

### 8.3.2 Mounting plate, wall version

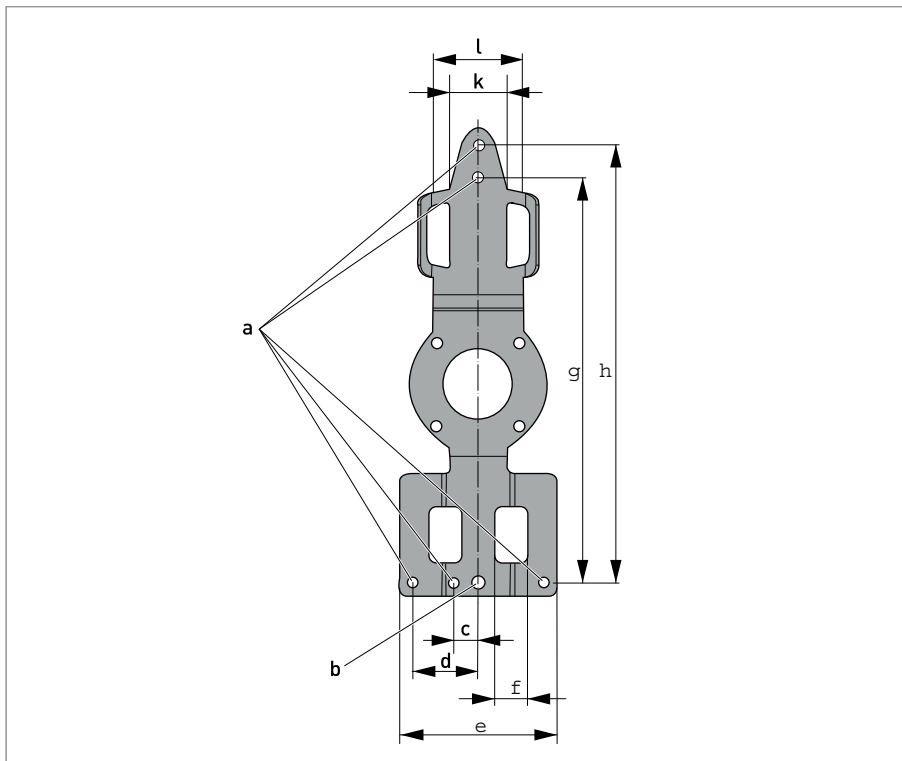

Figure 8-4: Dimensions of mounting plate, wall version

	[mm]	[inch]
a	Ø6.5	Ø0.26
b	Ø8.1	Ø0.3
c	15	0.6
d	40	1.6
e	96	3.8
f	20	0.8
g	248	9.8
h	268	10.5
k	35	1.4
l	55	2.2

Table 8-5: Dimensions in mm and inch

## 8.4 Flow tables

v [m/s]	Q <sub>100 %</sub> in m <sup>3</sup> /h			
	0.3	1	3	12
DN [mm]	Minimum flow	Nominal flow		Maximum flow
2.5	0.005	0.02	0.05	0.21
4	0.01	0.05	0.14	0.54
6	0.03	0.10	0.31	1.22
10	0.08	0.28	0.85	3.39
15	0.19	0.64	1.91	7.63
20	0.34	1.13	3.39	13.57
25	0.53	1.77	5.30	21.21
32	0.87	2.90	8.69	34.74
40	1.36	4.52	13.57	54.29
50	2.12	7.07	21.21	84.82
65	3.58	11.95	35.84	143.35
80	5.43	18.10	54.29	217.15
100	8.48	28.27	84.82	339.29
125	13.25	44.18	132.54	530.15
150	19.09	63.62	190.85	763.40
200	33.93	113.10	339.30	1357.20
250	53.01	176.71	530.13	2120.52
300	76.34	254.47	763.41	3053.64
350	103.91	346.36	1039.08	4156.32
400	135.72	452.39	1357.17	5428.68
450	171.77	572.51	1717.65	6870.60
500	212.06	706.86	2120.58	8482.32
600	305.37	1017.90	3053.70	12214.80
700	415.62	1385.40	4156.20	16624.80
800	542.88	1809.60	5428.80	21715.20
900	687.06	2290.20	6870.60	27482.40
1000	848.22	2827.40	8482.20	33928.80
1200	1221.45	3421.20	12214.50	48858.00

Table 8-6: Flow rate in m/s and m<sup>3</sup>/h

	Q <sub>100</sub> % in US gallons/min			
v [ft/s]	1	3.3	10	40
DN [inch]	Minimum flow	Nominal flow		Maximum flow
1/10	0.02	0.09	0.23	0.93
1/6	0.06	0.22	0.60	2.39
1/4	0.13	0.44	1.34	5.38
3/8	0.37	1.23	3.73	14.94
1/2	0.84	2.82	8.40	33.61
3/4	1.49	4.98	14.94	59.76
1	2.33	7.79	23.34	93.36
1.25	3.82	12.77	38.24	152.97
1.5	5.98	19.90	59.75	239.02
2	9.34	31.13	93.37	373.47
2.5	15.78	52.61	159.79	631.16
3	23.90	79.69	239.02	956.09
4	37.35	124.47	373.46	1493.84
5	58.35	194.48	583.24	2334.17
6	84.03	279.97	840.29	3361.17
8	149.39	497.92	1493.29	5975.57
10	233.41	777.96	2334.09	9336.37
12	336.12	1120.29	3361.19	13444.77
14	457.59	1525.15	4574.93	18299.73
16	597.54	1991.60	5975.44	23901.76
18	756.26	2520.61	7562.58	30250.34
20	933.86	3112.56	9336.63	37346.53
24	1344.50	4481.22	13445.04	53780.15
28	1829.92	6099.12	18299.20	73196.79
32	2390.23	7966.64	23902.29	95609.15
36	3025.03	10082.42	30250.34	121001.37
40	3734.50	12447.09	37346.00	149384.01
48	5377.88	17924.47	53778.83	215115.30

Table 8-7: Flow rate in ft/s and US gallons/min

### 8.5 Measuring accuracy

Every electromagnetic flowmeter is calibrated by direct volume comparison. The wet calibration validates the performance of the flowmeter under reference conditions against accuracy limits.

The accuracy limits of electromagnetic flowmeters are typically the result of the combined effect of linearity, zero point stability and calibration uncertainty.

#### Reference conditions

- Medium: water
- Temperature: +5...+35°C / +41...+95°F
- Operating pressure: 0.1...5 barg / 1.5...72.5 psig
- Inlet section: ≥ 5 DN; outlet section: ≥ 2 DN

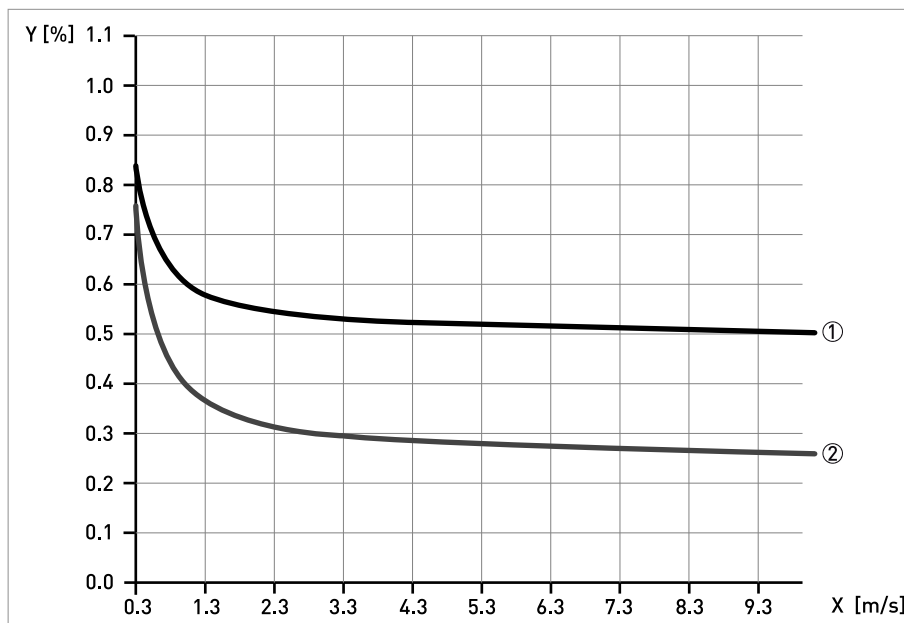

Figure 8-5: Measuring accuracy

X [m/s]: flow velocity

Y [%]: accuracy of measured value (mv)

	DN [mm]	DN [inch]	Standard accuracy ①	Optimised accuracy ②
OPTIFLUX 1050	10...150	3/8...6	±0.5% of mv ± 1 mm/s	-
OPTIFLUX 2050	10...1200	3/8...48		±0.25% of mv ± 1.5 mm/s
OPTIFLUX 4050				Extended calibration at 2 points
OPTIFLUX 5050	2.5...300	1/10...12		
OPTIFLUX 6050	10...150	3/8...6		
WATERFLUX 3050	25...600	1...24		-

Table 8-8: Measuring accuracy

## 9.1 General description

The open HART<sup>®</sup> protocol, which can be used freely, is integrated into the signal converter for communication.

Devices which support the HART<sup>®</sup> protocol are classified as either operating devices or field devices. When it comes to operating devices (Master), both manual control units (Secondary Master) and PC-supported workstations (Primary Master) are used in, for example, a control centre.

HART<sup>®</sup> field devices include flow sensors, signal converters and actuators. The field devices range from 2-wire to 4-wire to intrinsically safe versions for use in hazardous areas.

The HART<sup>®</sup> data are superimposed over the analogue 4...20 mA signal via FSK modem. This way, all of the connected devices can communicate digitally with one another via the HART<sup>®</sup> protocol while simultaneously transmitting the analogue signals.

When it comes to the field devices and secondary masters, the FSK or HART<sup>®</sup> modem is integrated, whereas with a PC communication takes place via an external modem which must be connected to the serial interface. There are, however, other connection variants which can be seen in the following connection diagrams.

## 9.2 Software history



### **INFORMATION!**

*In the table below, “\_” is a placeholder for possible multi-digit alphanumeric combinations, depending on the available version.*

Release date	Electronic revision (ER)	HART <sup>®</sup>	
		Device revision	DD revision
2012	ER 3.0.x_	1	1 and up
2021	ER 3.1.x_	1	1 and up

Table 9-1: Software history for HART<sup>®</sup> interface

Manufacturer ID:	69 (0x45)
Device Type Code:	203 (0xCB)
Device revision:	1
DD revision:	1 and up
HART <sup>®</sup> Universal Revision:	5
FDT version:	≥ 1.2

Table 9-2: HART<sup>®</sup> identification codes and revision numbers

### 9.3 Connection variants

The signal converter is a 4-wire device which is available in a variant with 4...20 mA current output and HART® interface.

Depending on the version, the settings and the wiring, the current output can operate as passive or active output.

- **Multi-drop mode is supported**

In a multi-drop communication system, more than 2 devices are connected to a common transmission cable.

- **Burst mode is not supported**

In the Burst mode a slave device transfers cyclic pre-defined response telegrams, to get a higher rate of data transfer.



**INFORMATION!**

*For detailed information about the electrical connection of the signal converter for HART®, refer to the section "Electrical connection".*

There are two ways of using the HART® communication:

- as Point-to-Point connection and
- as multi-drop connection, with 2-wire connection or as multi-drop connection, with 3-wire connection.

### 9.3.1 Point-to-Point connection - analogue / digital mode

Point-to-Point connection between the signal converter and the HART<sup>®</sup> Master.

The current output of the device may be active or passive.

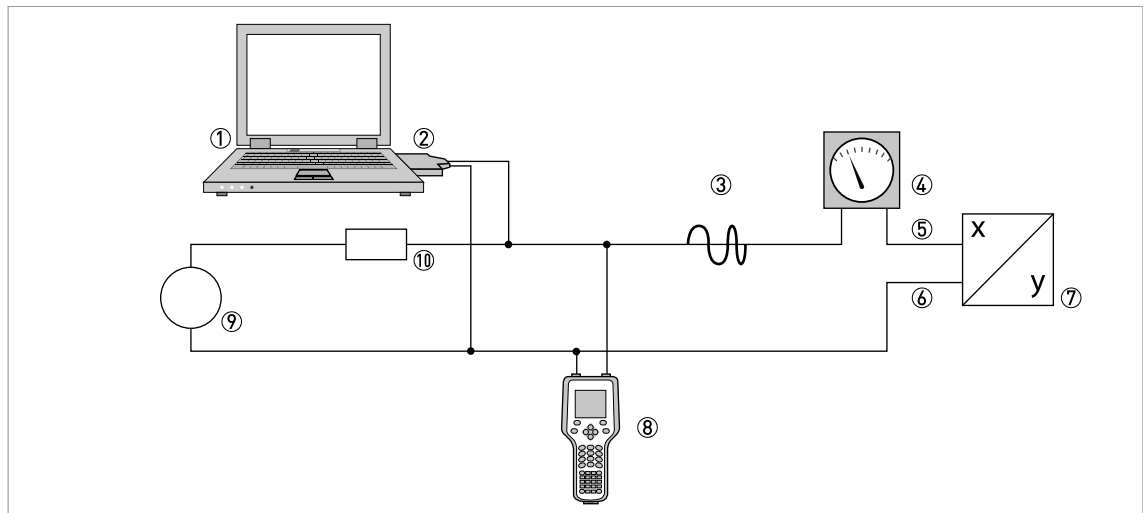

**Figure 9-1: Point-to-Point connection**

- ① Primary master
- ② FSK modem or HART<sup>®</sup> modem
- ③ HART<sup>®</sup> signal
- ④ Analog indication
- ⑤ Signal converter terminals A (C)
- ⑥ Signal converter terminals A- (C-)
- ⑦ Signal converter with address = 0 and passive or active current output
- ⑧ Secondary Master
- ⑨ Power supply for devices (slaves) with passive current output
- ⑩ Load  $\geq 230 \Omega$

### 9.3.2 Multi-drop connection (2-wire connection)

In the case of a multi-drop connection, up to 15 devices may be installed in parallel (this signal converter and other HART® devices).

The current outputs of the devices must be passive!

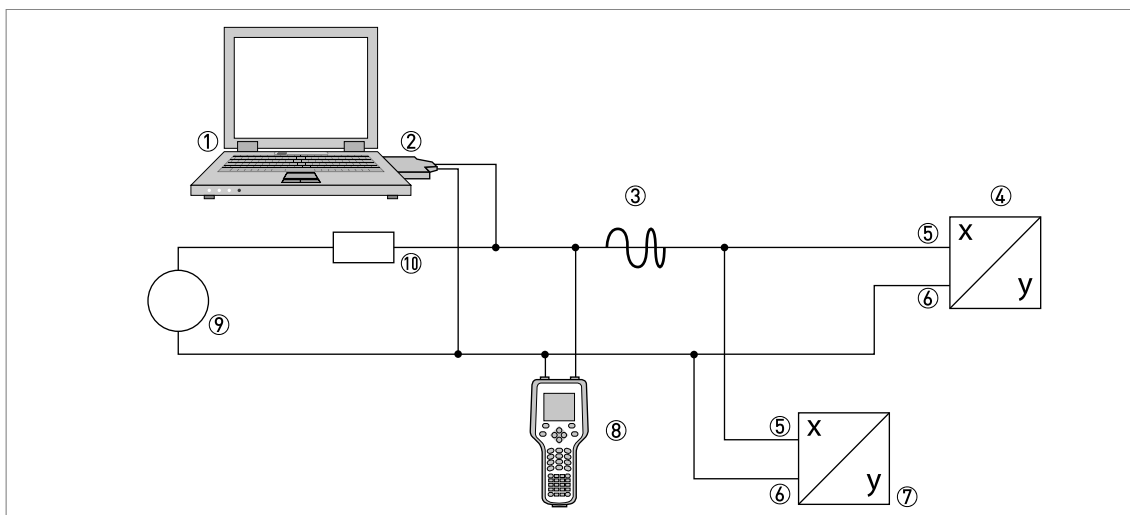

Figure 9-2: Multi-Drop connection (2-wire connection)

- ① Primary Master
- ② HART® modem
- ③ HART® signal
- ④ Other HART® devices or this signal converter (refer also to ⑦)
- ⑤ Signal converter terminals A (C)
- ⑥ Signal converter terminals A- (C-)
- ⑦ Signal converter with address  $\geq 0$  and passive current output, connection of max. 15 devices (slaves) with 4...20 mA
- ⑧ Secondary Master
- ⑨ Power supply
- ⑩ Load  $\geq 230 \Omega$

### 9.3.3 Multi-drop connection (3-wire connection)

Connection of 2-wire and 4-wire devices in the same network. In order that the current output of the signal converter is working continuously active, an additional third wire must be connected to the devices in the same network. These devices must be powered via a 2-wire loop.

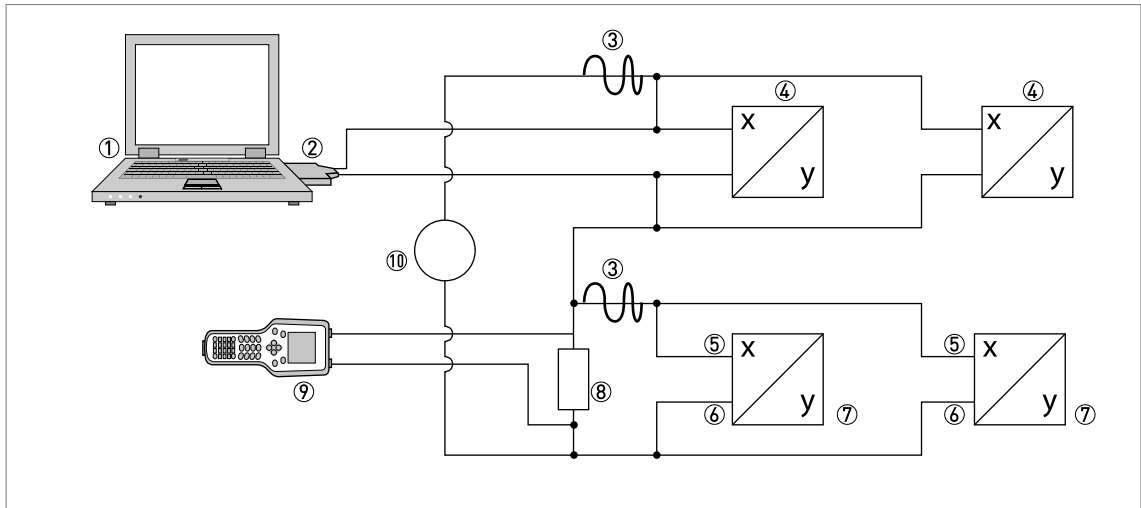

Figure 9-3: Multi-Drop connection (3-wire connection)

- ① Primary Master
- ② HART® modem
- ③ HART® signal
- ④ 2-wire external devices (slaves) with 4...20 mA, addresses > 0, powered by current loop
- ⑤ Signal converter terminals A (C)
- ⑥ Signal converter terminals A- (C-)
- ⑦ Connection of active or passive 4-wire devices (slaves) with 4...20 mA, addresses ≥ 0
- ⑧ Load ≥ 230 Ω
- ⑨ Secondary Master
- ⑩ Power supply

## 9.4 Inputs/outputs and HART dynamic variables and device variables

The signal converter is available with various input/output combinations.

The connection of the terminals A and D to the HART<sup>®</sup> dynamic variables PV, SV, TV and 4V depends on the device version.

PV = Primary Variable; SV = Secondary Variable; TV = Third Variable; 4V = Fourth Variable

Signal converter version	HART <sup>®</sup> dynamic variable			
	PV	SV	TV	4V
Basic I/O, connection terminals	A	D	-	-

Table 9-3: Connection of the terminals to the HART<sup>®</sup> dynamic variables

The signal converter can provide up to 8 measurement-related values. The measured values are accessible as so-called HART<sup>®</sup> device variables and can be connected to the HART<sup>®</sup> dynamic variables. The availability of these variables depends on the device versions and the settings.

Code = device variable code

HART <sup>®</sup> device variable	Code	Type	Explanations
flow speed	20	Linear	-
volume flow	21	Linear	
mass flow	22	Linear	
conductivity	24	Linear	
coil temperature	23	Linear	
counter 1	6	Counter	-
counter 2	14	Counter	
diagnosis value	25	Linear	Function and availability depends on diagnosis value setting.
operating hours	1	Counter	-

Table 9-4: Description of the HART<sup>®</sup> device variables

For the dynamic variables connected to the linear analogue outputs for current and/or frequency, the assignment of the device variables takes place by selecting the linear measurement for these outputs under the appropriate function of the signal converter. It follows that the dynamic variables connected to current or frequency outputs can only be assigned to the linear HART® device variables.

The HART® dynamic variable PV is always connected to the HART® current output which is, for example, assigned to the volume flow.

A totaliser device variable can thus not be assigned to the dynamic variable PV because the PV is always connected to the HART® current output.

Such correlations do not exist for dynamic variables not connected to linear analogue outputs. Both linear and totaliser device variables can be assigned.

The totaliser device variables can only be assigned to the dynamic variables SV, TV and 4V if the connected output is not a current or frequency output.

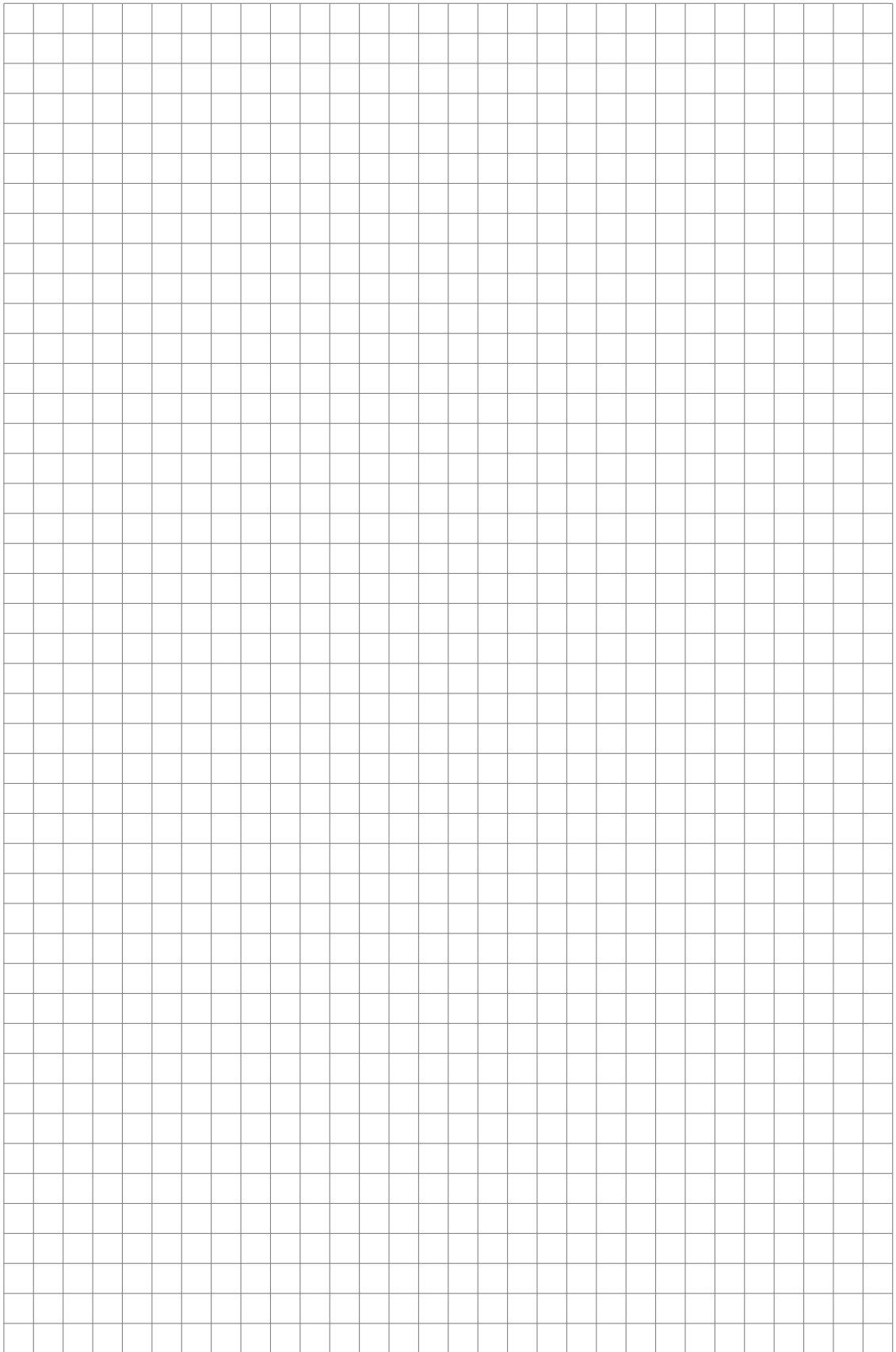

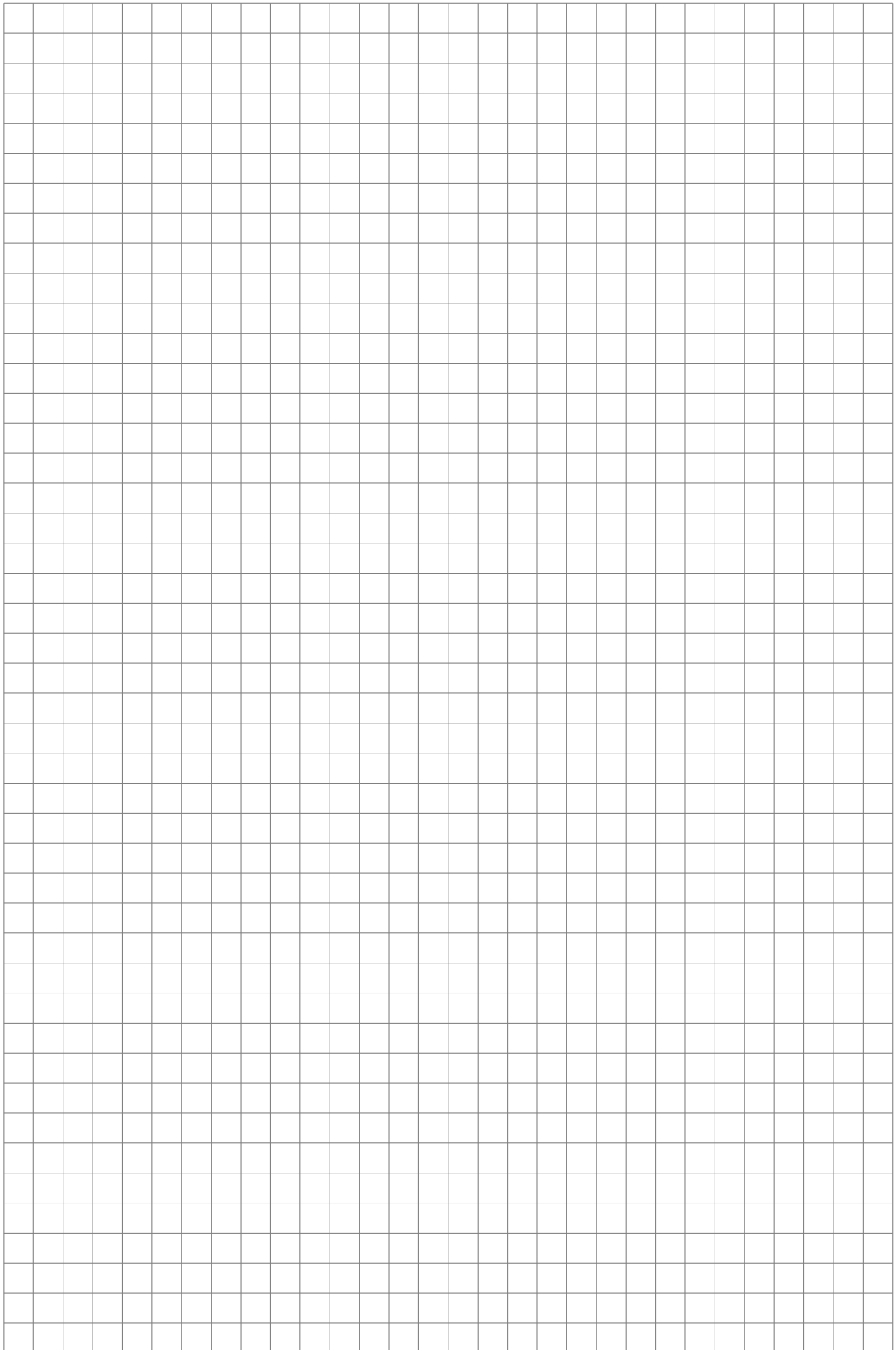



**JUMO GmbH & Co. KG**

Street address:  
Moritz-Juchheim-Straße 1  
36039 Fulda, Germany  
Delivery address:  
Mackenrodtstraße 14  
36039 Fulda, Germany  
Postal address:  
36035 Fulda, Germany  
Phone: +49 661 6003-0  
Fax: +49 661 6003-607  
Email: [mail@jumo.net](mailto:mail@jumo.net)  
Internet: [www.jumo.net](http://www.jumo.net)

**JUMO Instrument Co. Ltd.**

JUMO House  
Temple Bank, Riverway  
Harlow, Essex, CM20 2DY, UK  
Phone: +44 1279 63 55 33  
Fax: +44 1279 62 50 29  
Email: [sales@jumo.co.uk](mailto:sales@jumo.co.uk)  
Internet: [www.jumo.co.uk](http://www.jumo.co.uk)

**JUMO Process Control, Inc.**

6724 Joy Road  
East Syracuse, NY 13057, USA  
Phone: +1 315 437 5866  
Fax: +1 315 437 5860  
Email: [info.us@jumo.net](mailto:info.us@jumo.net)  
Internet: [www.jumousa.com](http://www.jumousa.com)

