

# JUMO flowTRANS MAG H20

Electromagnetic flowmeter  
for liquids



 Bluetooth®  IO-Link

IO-Link operating manual



40606511T90Z001K000

V1.00/EN/30050597/2025-02-12

**Further information and downloads**



[qr-406065-en.jumo.info](https://qr-406065-en.jumo.info)

# Table of contents

---

<b>1</b>	<b>About this documentation</b>	<b>6</b>
1.1	Purpose	6
1.2	Target group	6
1.3	Definition of terms	6
1.4	Trademark information	6
1.5	Symbols	6
<b>2</b>	<b>Safety</b>	<b>7</b>
2.1	Intended use	7
2.2	Qualification of personnel	7
2.3	Hot surfaces	7
2.4	Hazardous materials	7
2.5	Mechanical loads	7
2.6	Transport and storage damage	8
<b>3</b>	<b>Description</b>	<b>9</b>
3.1	Structure	9
3.2	Functions	9
3.3	Nameplate	10
3.4	Approval marks and certificates	10
3.5	Device ID	11
3.6	Scope of delivery	11
<b>4</b>	<b>Technical data</b>	<b>12</b>
4.1	Electrical safety	12
4.2	Electrical data	12
4.3	Inputs	13
4.3.1	Measurands	13
4.3.2	Digital inputs	14
4.4	Outputs	14
4.4.1	Analog outputs	14
4.4.2	Digital outputs	15
4.5	Interfaces	16
4.5.1	Bluetooth	16
4.5.2	IO-Link	16
4.6	Display	16
4.7	Environmental influences	17
4.8	Mechanical features	17
4.8.1	Materials	17

---

# Table of contents

---

4.8.2	Nominal pressure	18
4.8.3	Pressure loss diagram	18
4.9	Measurement media	18
4.10	Dimensions	19
4.10.1	Device	19
<b>5</b>	<b>Installation</b>	<b>21</b>
5.1	Preparing for installation	21
5.1.1	Installation site	21
5.1.2	Installation position	21
5.1.3	Avoid mechanical strain	22
5.1.4	Flow direction	22
5.1.5	Alignment of the housing for electronic components	22
5.2	Installing the device	23
<b>6</b>	<b>Electrical connection</b>	<b>25</b>
6.1	Connection elements	25
6.1.1	Terminal assignment	25
6.2	Connection diagram	25
6.2.1	Digital inputs	25
6.2.2	Analog outputs	26
6.2.3	Digital outputs	26
6.3	Connecting the device	28
<b>7</b>	<b>Operation</b>	<b>29</b>
7.1	Display elements	29
7.1.1	Startup display	29
7.1.2	Process display	29
7.1.3	Error messages	31
7.2	Interfaces	32
7.2.1	Bluetooth	32
7.2.2	IO-Link	32
<b>8</b>	<b>Functional descriptions</b>	<b>33</b>
8.1	Limit value monitoring	33
<b>9</b>	<b>Configuration via Bluetooth®</b>	<b>36</b>
9.1	Device	36
9.2	Measurands	36
9.3	Bluetooth	38
9.4	Display	38
9.5	Totalizer	38
9.6	Batch	39
9.7	Limit value monitoring	39

---

# Table of contents

---

9.8	Analog output	.41
9.9	Digital output	.42
9.10	IO-Link	.43
9.11	Digital input	.43
9.12	Pulse output	.43
<b>10</b>	<b>Configuration via IO-Link</b>	<b>.44</b>
10.1	Device	.44
10.2	Measurands	.45
10.3	Bluetooth	.47
10.4	Display	.47
10.5	Totalizer	.48
10.6	Batch	.49
10.7	Limit value monitoring	.49
10.8	Analog output	.53
10.9	Digital output	.55
10.10	IO-Link	.56
10.11	Digital input	.57
10.12	Pulse output	.57
<b>11</b>	<b>Cyclic data transfer via IO-Link</b>	<b>.58</b>
<b>12</b>	<b>Troubleshooting</b>	<b>.59</b>
12.1	Process value error	.59
12.2	Error messages in line with NAMUR	.60
12.3	Error messages outside NAMUR	.62
<b>13</b>	<b>Maintenance and cleaning</b>	<b>.63</b>
13.1	Cleaning device housing	.63
13.2	Decontamination	.63
13.3	Replacing sealing rings/O-rings	.63
<b>14</b>	<b>Shutdown</b>	<b>.64</b>
14.1	Uninstallation	.64
14.2	Returns	.64
14.3	Disposal	.64
<b>15</b>	<b>Accessories</b>	<b>.65</b>
<b>16</b>	<b>Open-source software</b>	<b>.66</b>

---

# 1 About this documentation

---

## 1.1 Purpose

This documentation is part of the device and includes all information to ensure that it is used safely and as intended across all phases of the product lifecycle.

If you do not follow the documentation and safety information, this may result in risk to life and damage to property due to improper use.

- Read and follow the documentation and the safety information and warnings.
- Store the document in its entirety, in an easily accessible location, and so that it can be read in full at all times.
- Contact the manufacturer if you have any questions about the device and documentation.

## 1.2 Target group

This documentation is intended to be used by personnel trained in electrical, mechanical, and plant engineering across all phases of the product lifecycle.

## 1.3 Definition of terms

Use in the documentation	Definition
Device, product	Electromagnetic flowmeter for liquids
Medium, measurement medium	Liquid
Flow	Totalized flow rate per time span
Product lifecycle	Overall consideration of product identification, storage, connection, installation, operation, troubleshooting, maintenance up to disposal

## 1.4 Trademark information

All trademarks and trade and company names used are the property of their rightful owners or authors.

## 1.5 Symbols

### NOTE!



This symbol is used in tables and indicates that further information is provided after the table.

---

### REFERENCE!



This symbol refers to **further information** in other sections, chapters, or other manuals.

---

### 2.1 Intended use

The electromagnetic flowmeter measures the flow and temperature of conductive liquid media. It is mounted in pipes made from plastic or metal.

The documentation is part of the device. The device is only intended for use according to this documentation.

### 2.2 Qualification of personnel

The personnel deployed must meet the following requirements in all phases of the product lifecycle:

- Trained electrical, mechanical, and plant engineering personnel.
- Members of personnel are familiar with this documentation and the safety information and warnings it contains.

### 2.3 Hot surfaces

Hot device surfaces pose a risk of injury. Hot device surfaces can be caused by the use of hot media in applications.

- If required, install contact protection.
- Take into account the alignment of the housing for electronic components, ⇒page 22.

When working on the device:

- Allow the device and plant to cool down.
- Wear suitable protective equipment.

### 2.4 Hazardous materials

Using hazardous materials as a medium may result in abrasive and corrosive damage to components of the product that come into contact with the medium. The medium may leak and present a fire hazard and a risk to health.

Carry out a risk assessment taking into consideration the safety data sheet for the relevant hazardous substance for mounting, operation, maintenance, cleaning, and disposal:

- Comparison and systematic checking of the durability of the components of the product that come into contact with the medium and the admissible environmental influences.
- Assessment of the risk to people and the environment.
- Assessment of the fire hazard due to the product materials, the admissible environmental influences, and the voltage supply.

### 2.5 Mechanical loads

Mechanical load on the device and process connections can lead to leaks.

- Do not place the device and the process connections under mechanical strain.
- Systematically check that the process connections are leak-tight.

## 2 Safety

---

### 2.6 Transport and storage damage

The device can be damaged if it is insufficiently protected during transport and/or improperly stored.

- Transport the device protected from moisture and dirt in shockproof packaging.
- Protect all electrical and mechanical connections from damage.
- Observe the admissible storage temperature of the device.
- Store the device in a dry and dust-free environment.

## 3.1 Structure

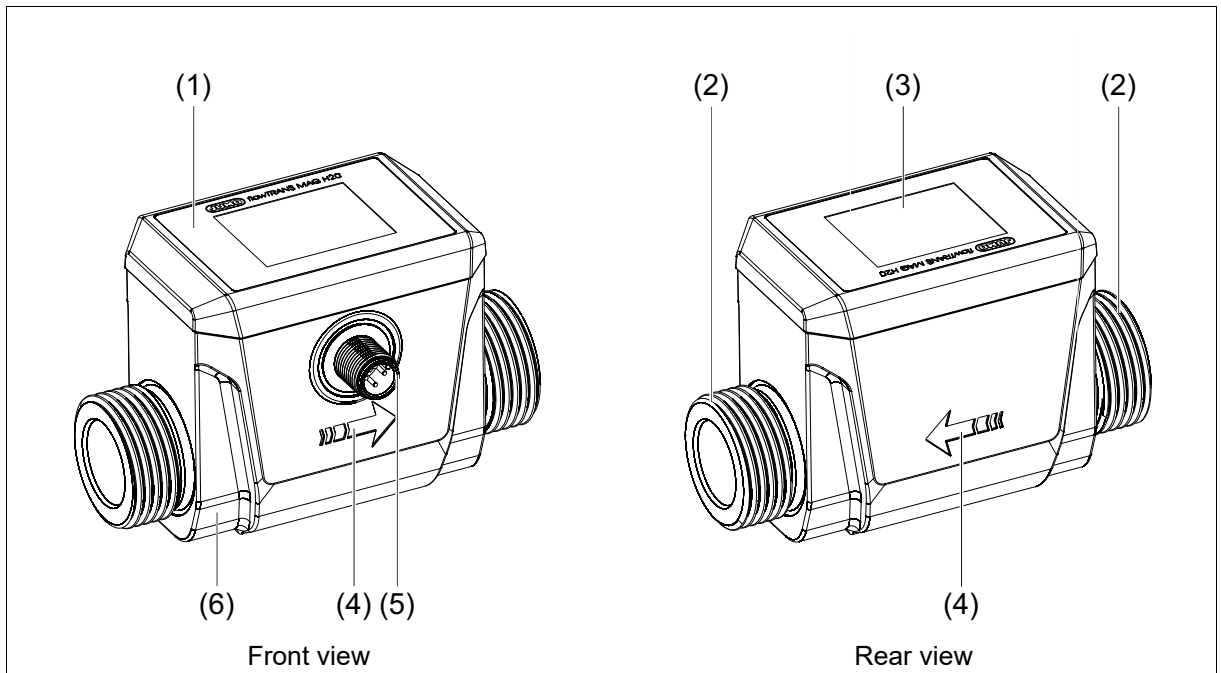

- 1 Top section of the housing
- 2 Process connection
- 3 Display

- 4 Flow direction
- 5 M12 plug connector
- 6 Case bottom section

## 3.2 Functions

The device records the flow according to the principle of electromagnetic flow measurement. This principle is based on Faraday's law of induction.

An electrically conductive liquid flows through a measuring pipe. A magnetic field is generated in the measuring pipe perpendicular to the flow direction. The magnetic field is created by current flowing through a pair of field coils.

The magnetic field induces a voltage in the liquid. Two electrodes are located opposite each other on the measuring pipe. The electrodes pick up the generated voltage and transmit the measurement results to the integrated evaluation electronics.

# 3 Description

## 3.3 Nameplate

Example:

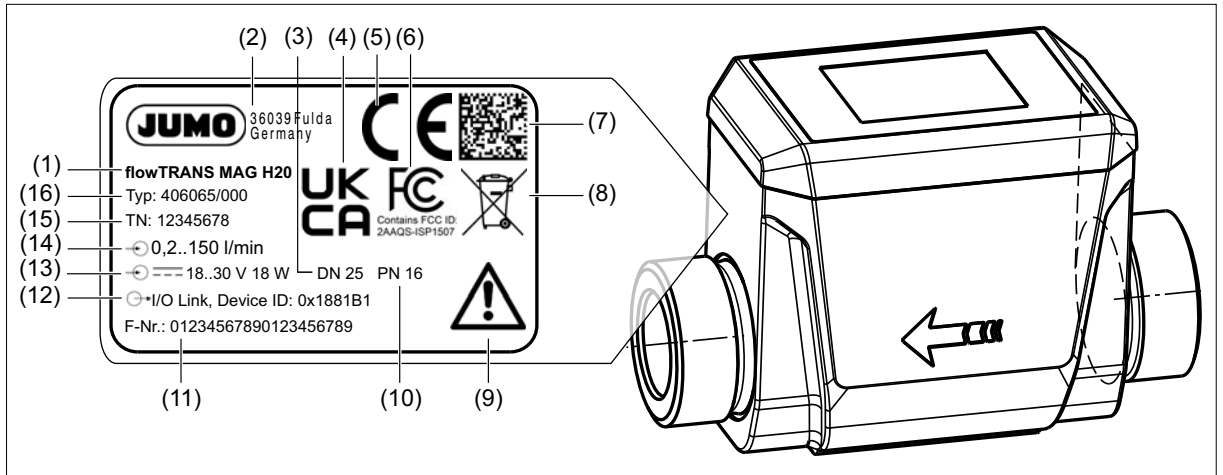

- |   |                             |    |                               |
|---|-----------------------------|----|-------------------------------|
| 1 | Device designation          | 9  | Observe device documentation! |
| 2 | Manufacturer and address    | 10 | Nominal pressure level        |
| 3 | Nominal width               | 11 | Fabrication number            |
| 4 | UKCA identification marking | 12 | IO-Link device ID             |
| 5 | CE identification marking   | 13 | Voltage supply (DC)           |
| 6 | FCC identification marking  | 14 | Measuring range               |
| 7 | Data Matrix Code            | 15 | Part no.                      |
| 8 | Disposal                    | 16 | Order code                    |

## 3.4 Approval marks and certificates

### Radio Equipment Directive (RED)

JUMO GmbH & Co. KG hereby states that the flowTRANS MAG H20 device complies with the Directive 2014/53/EU. The full text of the EU declaration of conformity is available at the following web address: [qr-406065-en.jumo.info](http://qr-406065-en.jumo.info).

### Radio equipment regulations 2017

JUMO GmbH & Co. KG hereby states that the flowTRANS MAG H20 device complies with the radio equipment regulations UK S.I. 2017 No. 1206. The full text of the UK Declaration of Conformity is available at the following web address: [qr-406065-en.jumo.info](http://qr-406065-en.jumo.info).

### Federal Communications Commission (FCC)

This device complies with part 15 of the FCC rules. Operation is subject to the following two conditions.

- (1) This device may not cause harmful interference.
- (2) This device must accept any interference received, including interference that may cause undesired operation.

Caution: Any Changes or modifications not expressly approved by the party responsible for compliance could void the user's authority to operate the equipment.

## 3.5 Device ID

The device ID is shown on the nameplate (⇒ Page 10) and identifies the device version. A device description file (IODD) is assigned to each device ID which is used for communication via the IO-Link interface, ⇒ Page 32.

Device ID	Device version	IODD
0x088031	Magmeter DN06	JUMO-088031-XXXXXXXX <sup>a</sup> -IODD <sup>b</sup> .xml
0x0880B1	Magmeter DN15	JUMO-0880B1-XXXXXXXX <sup>a</sup> -IODD <sup>b</sup> .xml
0x088131	Magmeter DN20	JUMO-088131-XXXXXXXX <sup>a</sup> -IODD <sup>b</sup> .xml
0x0881B1	Magmeter DN25	JUMO-0881B1-XXXXXXXX <sup>a</sup> -IODD <sup>b</sup> .xml

<sup>a</sup> Date (YearMonthDay) of the IODD release.

<sup>b</sup> Version of the IODD.

## 3.6 Scope of delivery

Device in the ordered version
Brief instructions

### Without FDA approval

2 × Centellen seals (only for variant with threaded connector)
--

## 4 Technical data

---

### 4.1 Electrical safety

Requirements	DIN EN 61010-1 The device must be equipped with an electrical circuit that meets the requirements for "Limited-energy circuits".
--------------	---

### 4.2 Electrical data

Voltage supply	DC 18 to 30 V PELV
Current consumption	
IO-Link operation	≤ 100 mA
Operation with switching output	≤ 600 mA
Power consumption	
IO-Link operation	≤ 3 W
Operation with switching output	≤ 18 W
Protection rating	DIN EN 61140, Class III (protective low voltage)
Electrical connection	
Connection elements	
Device	M12 plug connector, grounding terminal M4
Connecting cable	M12 plug connector
Grounding cable	Ring cable lug M4
Connecting cable	
Line length	≤ 20 m, unshielded
Temperature resistance	≥ 80 °C

## 4.3 Inputs

### 4.3.1 Measurands

#### Flow

$Flow_{max}$ DN 06 DN 15 DN 20 DN 25	0.005 to 5 l/min 0.05 to 35 l/min 0.1 to 75 l/min 0.2 to 150 l/min
Reference conditions Measurement medium Medium temperature Ambient temperature Medium pressure Measuring pipe Accuracy Response time $t_{90}$	Water 23 °C (73 °F) $\pm 5$ °C 23 °C (73 °F) $\pm 5$ °C 1 to 4 bar Horizontal installation 0.5 % of the measured value $\pm 1.5$ mm/s $\leq 250$ ms
Application conditions Accuracy Repeatability	0.8 % of the measured value $\pm 1.5$ mm/s +0.2 % of the measured value $\pm 1$ mm/s
X = Flow (%) in relation to $flow_{max}$ Y = Deviation (%) from measured value	

#### Temperature

Measuring range	-20 to +90 °C
Accuracy	$\pm 2,5$ K

## 4 Technical data

---

### 4.3.2 Digital inputs

Function	Reset totalizer, start/stop batch, measured value suppression
Type	Logic input (external voltage supply)
Switching voltage $V_{DI}$	DC $-30\text{ V} \leq V_{DI} \leq +30\text{ V}$
Protection	Against polarity and voltage peaks
Internal resistance	$> 100\text{ k}\Omega$
Switching thresholds	PLC level: logic level "0" $< 7\text{ V}$ , logic level "1" $> 15\text{ V}$

## 4.4 Outputs

### 4.4.1 Analog outputs

Current output	
Function	Output of the flow process values and temperature; output of a signal for error messaging
Signal range	4 to 20 mA
Signal limits	3.8 to 22 mA
Error message	3.4 or 22 mA or replacement value
Temperature influence	75 ppm/K
Burden	$\leq 500\ \Omega$
Burden influence	$\leq \pm 0.02\%$ per $100\ \Omega$
Voltage output	
Function	Output of the flow process values and temperature; output of a signal for error messaging
Signal range	DC 0 to 10 V
Signal limits	DC 0 to 11 V
Error message	DC 0 or 11 V or replacement value
Temperature influence	75 ppm/K
Load	$\geq 2000\ \Omega$
Load influence	$\leq \pm 15\text{ mV}$

### 4.4.2 Digital outputs

Type	Transistor output as switching output or pulse output (I/O pin 1 only)
Protection	Against polarity reversal, short circuiting and overload
Output signal	Push-pull, PNP, NPN
Ampacity	≤ 100 mA
Voltage drop	≤ 3 V
Switching output	
Function	Limit value monitoring function
Input signal	Flow, temperature
Output signal	Limit value monitoring function, batch active, batch error, device error
Switch-on and switch-off delay	0 to 100 s
Limit value function	Hysteresis (NO contact/NC contact), window (NO contact/NC contact), switch-on and switch-off delay
Switching point	Configurable
Pulse output	
Function	Output of the flow process value
Pulse frequency	0 to 10 kHz
Duty cycle	50 %
Output value at nominal width <sup>a</sup>	Pulses per liter (l)
DN 06	120000
DN 15	17100
DN 20	8000
DN 25	4000

<sup>a</sup> Default setting (configurable).

## 4 Technical data

---

### 4.5 Interfaces

#### 4.5.1 Bluetooth

Function	Transfer of configuration data and device information, display of process values
Communication	Via end device with JUMO smartCONNECT app
Authentication	Via Bluetooth® radio module and NFC tag
Connection status (configurable) Permanently Temporarily	Active Restricted (via NFC)
Range	10 m under reference conditions
Radio frequency Bluetooth® radio module NFC tag	2.4 GHz 13.56 MHz
Max. transmission power Bluetooth® radio module NFC tag	0 dBm –
JUMO smartCONNECT app System requirements iOS device Android device	iPhone 7 or later (recommended) with iOS 13 Android 8.0 or later

#### 4.5.2 IO-Link

Function	Transfer of process data, configuration data and device information, displaying of process values
Communication	Via end device with IO-Link master and device description file (IODD)
Communication interface	IO-Link device V 1.1
Data transfer rate (baud rate)	COM 3 (230.4 kBaud)
Cycle time	≥ 5 ms
Profile	Common Profile, Smart Sensor Profile

### 4.6 Display

Type	TFT display
Size Display range Screen size (diagonal)	35.04 × 28.03 mm 1.77"
Resolution	128 × 160 RGB
Brightness	10 levels active + 1 level inactive (configurable)
Rotation	0°, 90°, 180°, 270° (configurable)

### 4.7 Environmental influences

Admissible ambient temperature At a medium temperature $\leq 80$ °C At medium temperature of > 80 °C	DIN 60068-2-1, DIN 60068-2-2 -20 to +55 °C -20 to +45 °C
Admissible storage temperature	-20 to +60 °C
Climatic conditions Climate class Air temperature Relative humidity	DIN EN 60721-3-3 3K6 -20 to +55 °C $\leq 100$ % – condensation on device outer shell
Protection type	DIN EN 60529, EN 50102 IP65, IP67
Pollution degree	2
Electromagnetic compatibility (EMC) Interference emission Interference immunity	DIN EN 61326-1:2022, DIN EN 61326-2-3:2022 Class B <sup>a</sup> Industrial requirements
Oscillation Amplitude Acceleration	DIN EN 60068-2-6 0.35 mm at 10 to 2000 Hz 50 m/s <sup>2</sup> at 10 to 2000 Hz
Shock Peak acceleration Shock duration	DIN EN 60068-2-27 200 m/s <sup>2</sup> 11 ms
Pressure Equipment Directive Group 1 fluids - DN $\leq 25$	2014/68/EU Sound engineering practice according to Art. 4 (3) in conjunction with Art. 4 (1c.i)
Site altitude	$\leq 2000$ m above sea level

<sup>a</sup> The product is suitable for industrial use as well as for households and small businesses.

### 4.8 Mechanical features

#### 4.8.1 Materials

Housing Top section of the housing Case bottom section Threaded sleeve M12 × 1 Display	PA-GF25 (glass fiber reinforced) Stainless steel 304 Stainless steel 304 PMMA
Components in contact with the medium Process connection O-ring, sealing ring Measuring pipe Electrodes	Drinking-water-certified materials (when using EPDM seals) 1.4404 (stainless steel 316L) EPDM, FKM (optional) PEEK Carbon fiber

## 4 Technical data

### 4.8.2 Nominal pressure

Nominal pressure level	PN 16
------------------------	-------

### 4.8.3 Pressure loss diagram

Created under reference conditions ⇨ page 13.

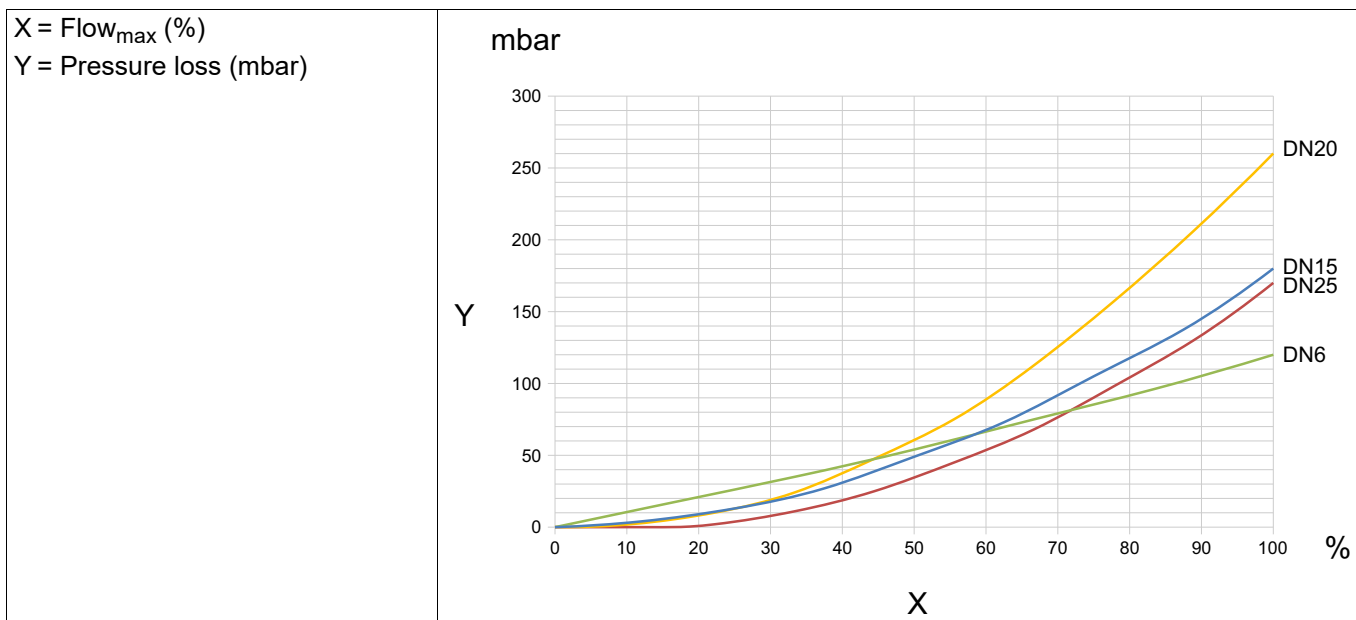

### 4.9 Measurement media

Medium type	Conductive liquids
Conductivity	≥ 20 μS/cm
Viscosity	≤ 70 mPa·s
Temperature range	-20 °C to +90 °C

## 4.10 Dimensions

### 4.10.1 Device

Threaded connector according to DIN EN ISO 228-1

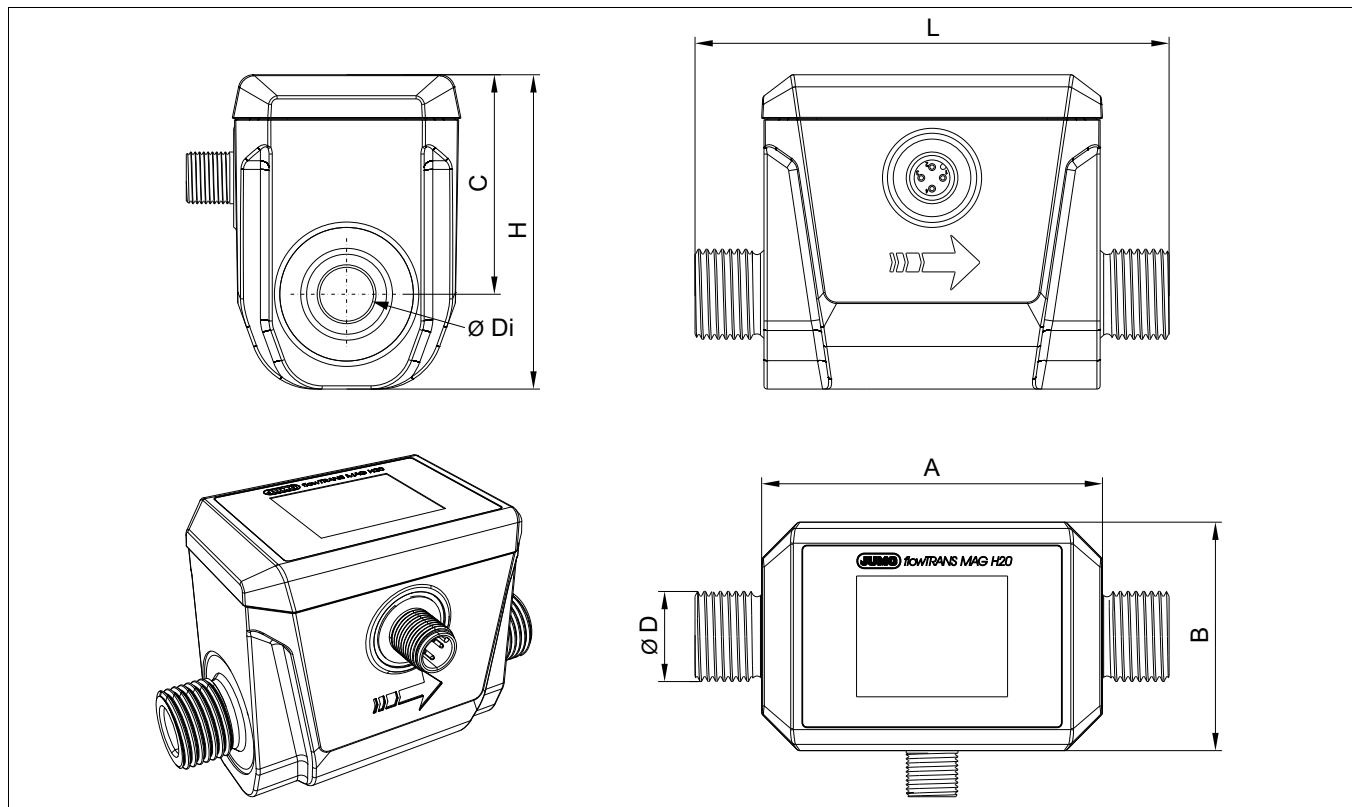

Nominal width	Ø Di [mm]	Ø D ["]	A [mm]	B [mm]	C [mm]	L [mm]	H [mm]
DN 6	6	1/4	79	53	51	110	73
DN 15	12.5	1/2					
DN 20	15	3/4					
DN 25	21	1					

## 4 Technical data

Tri-Clamp connection according to DIN 32676, Series A

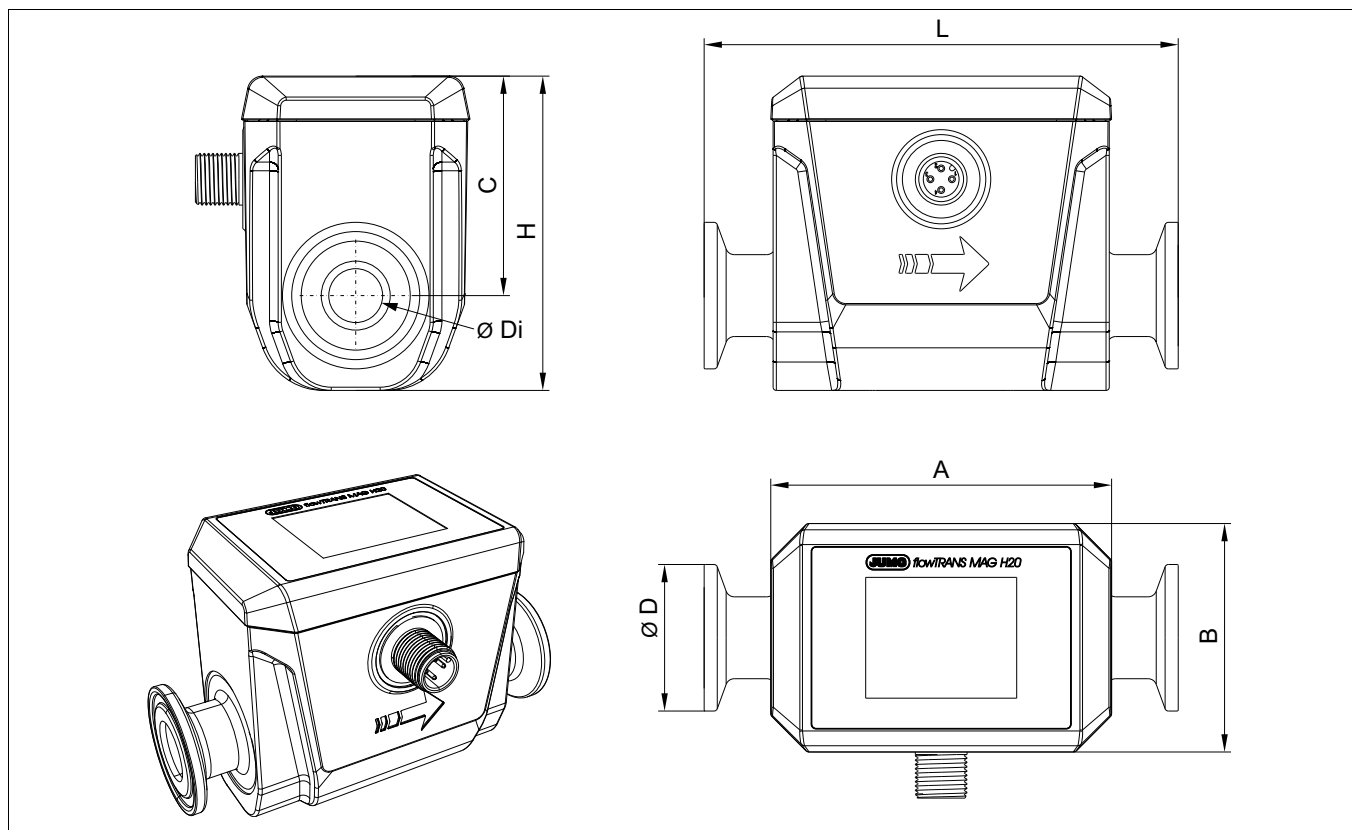

Nominal width	Ø Di [mm]	Ø D [mm]	A [mm]	B [mm]	C [mm]	L [mm]	H [mm]
DN 6	6	25	79	53	51	110	73
DN 15	12.5	34					
DN 20	15	34					
DN 25	26	50				130	

## 5.1 Preparing for installation

### 5.1.1 Installation site

Requirements:

- The device is protected from electromechanical interference.
- The device is protected from UV radiation.
- The device is protected from the weather in outdoor applications.

### 5.1.2 Installation position

→ = Flow direction

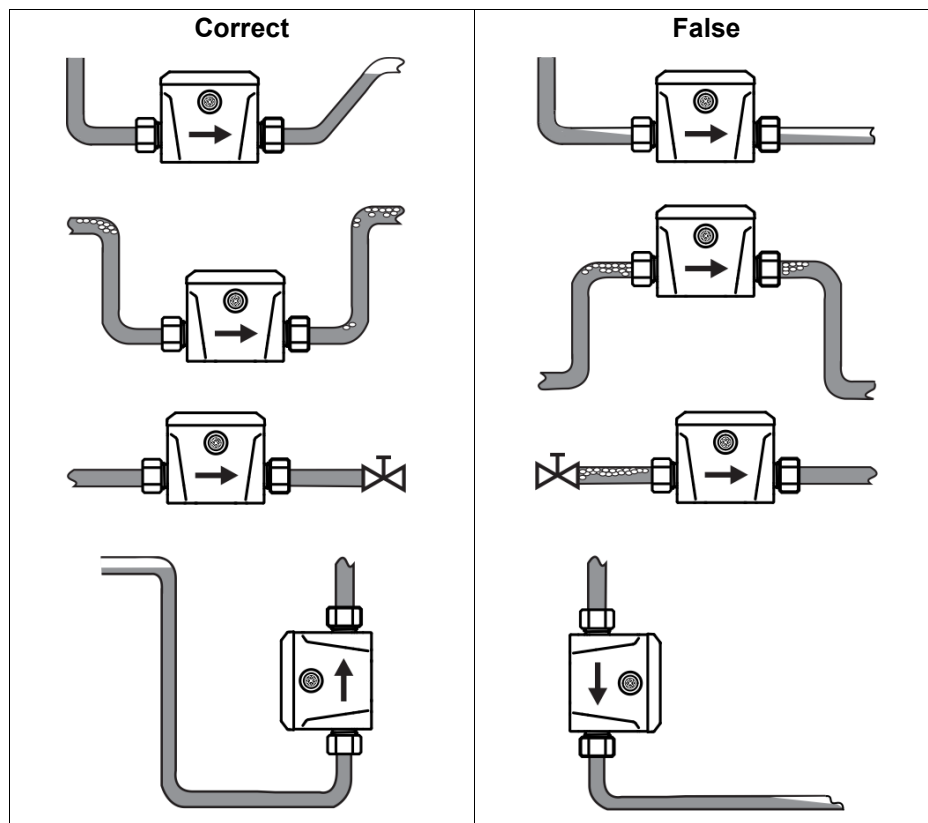

# 5 Installation

## 5.1.3 Avoid mechanical strain

Requirements:

- The center axes of both ends of the pipes are aligned before mounting in the pipe (1) (A-B).
- The ends of the pipes are aligned parallel and at an angle to one another (C).
- The insertion length (L) of the device is adhered to.

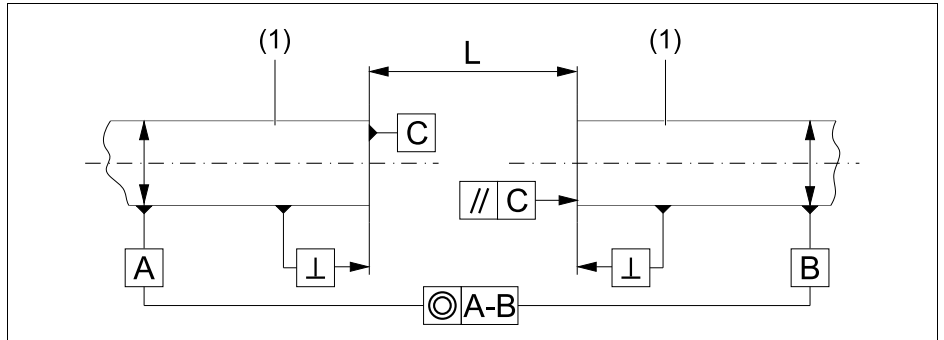

Nominal width	Insertion length X [mm]
DN 6	110
DN 15	110
DN 20	110
DN 25 with thread	110
DN 25 with Tri-Clamp	130

## 5.1.4 Flow direction

The positive flow direction (→) is shown on both sides of the device and must be observed during installation, in accordance with the application in question.

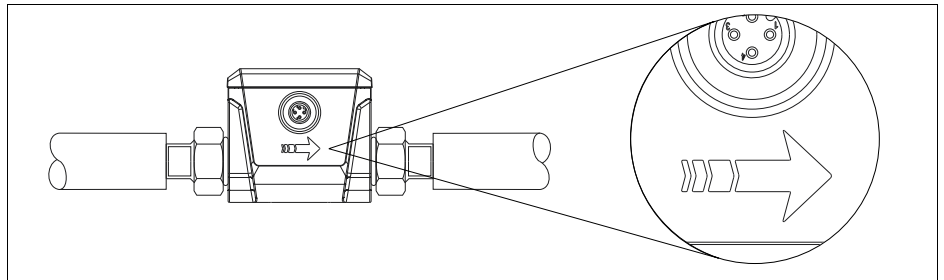

## 5.1.5 Alignment of the housing for electronic components

**CAUTION!** Protect the electronics housing from heating up by hot media. Install the electronics housing oriented 180° to the side at medium temperatures > 70 °C (158 °F).

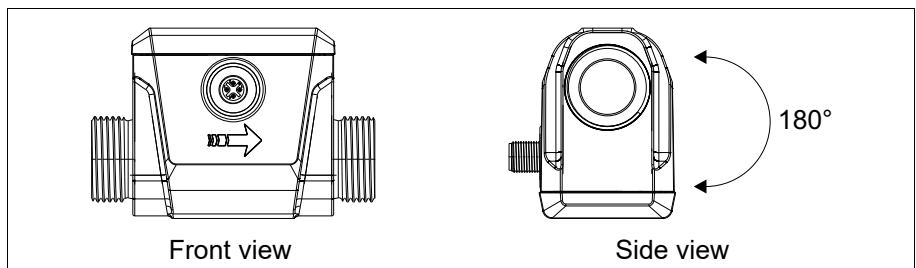

## 5.2 Installing the device

Material	Suitable tool
	Lubricating paste
	2 seals (for variant with threaded connector, the seals are included in the scope of delivery)
Threaded connector	2 suitable pipe adapters
	Suitable sealing material depending on pipe adapter
Tri-Clamp connection	2 Tri-Clamp clamps

### Requirements:

- The system has been de-energized and secured against being switched on again.
- The medium circulation of the plant is stopped.
- The pipe is drained and rinsed.
- Suitable protective equipment has been set up.
- The pipe is prepared for installation with the mounting kits.

### Procedure:

#### Threaded connector (DIN EN ISO 228-1)

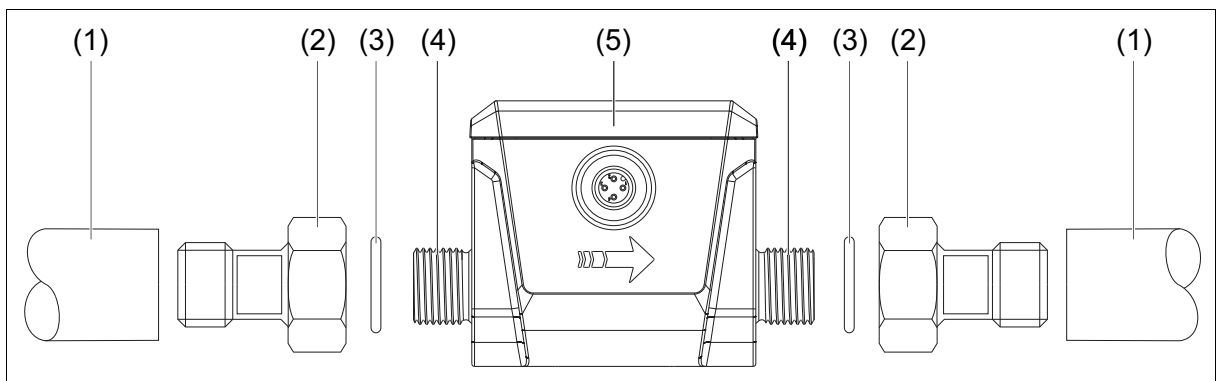

1. Lubricate the threads of the process connections (4) and the pipe adapters (2) with lubricating paste.
2. Screw the pipe adapters (2) into the pipes (1).
3. Make sure that the connections are tight.
4. Insert one seal (3) each into a pipe adapter.
5. Insert the device (5) according to the marked flow direction (→).
6. Screw the pipe adapters (2) hand-tight to the process connections (4).
7. Tighten the two adapters (2) in opposite directions.

Tightening torque DN 6: 15 Nm

Tightening torque DN 15 to DN 25: 30 Nm

*The device is now installed in the pipe.*

## 5 Installation

---

### Tri-Clamp connection (DIN 32676, Series A)

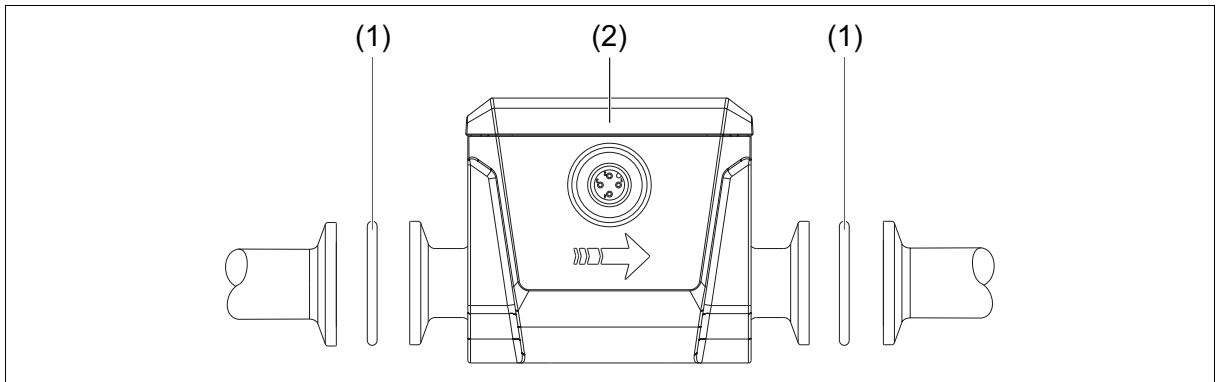

1. Insert the device (2) according to the marked flow direction (→).
2. Insert a suitable seal (1) between the two Tri-Clamp flanges on each side of the device.
3. Position one Tri-Clamp clamp around each of the two Tri-Clamp flanges on both sides of the device.
4. Fix the Tri-Clamp clamps.

*The device is now installed in the pipe.*

## 6.1 Connection elements

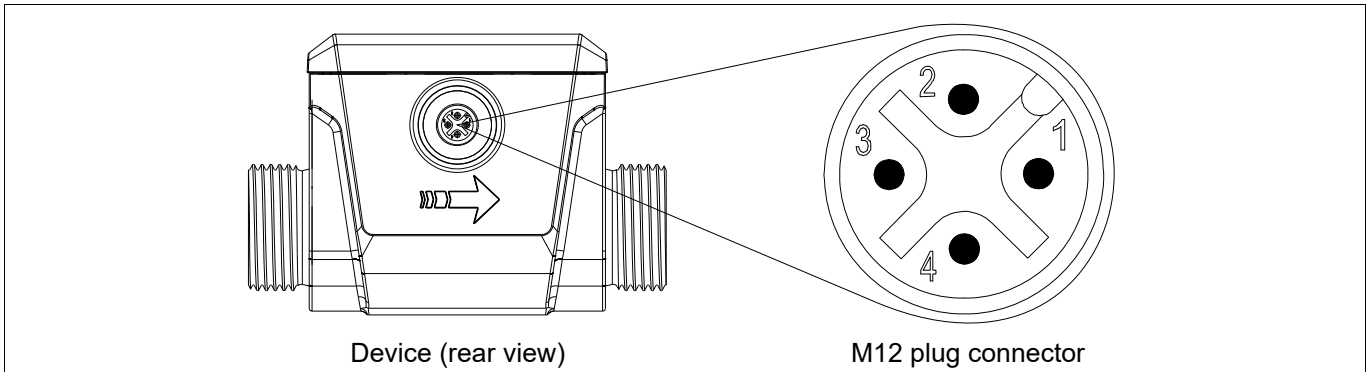

### 6.1.1 Terminal assignment

#### M12 plug connection

Designation	Description	Assignment
IO-Link	DC 24 V	1 BN (Brown)
	I/O-Pin 2 <sup>a</sup>	2 WH (White)
	GND	3 BU (Blue)
	IO-Link, I/O-Pin 1 <sup>b</sup>	4 BK (Black)

<sup>a</sup> Configurable as: Digital input, digital output, analog output.

<sup>b</sup> Configurable as: IO-Link, digital output, analog output.

## 6.2 Connection diagram

### Requirements:

- An unused current output is connected to GND.
- An unused voltage output is open.

### 6.2.1 Digital inputs

PLC level: logic level "0" < 7 V, logic level "1" > 15 V

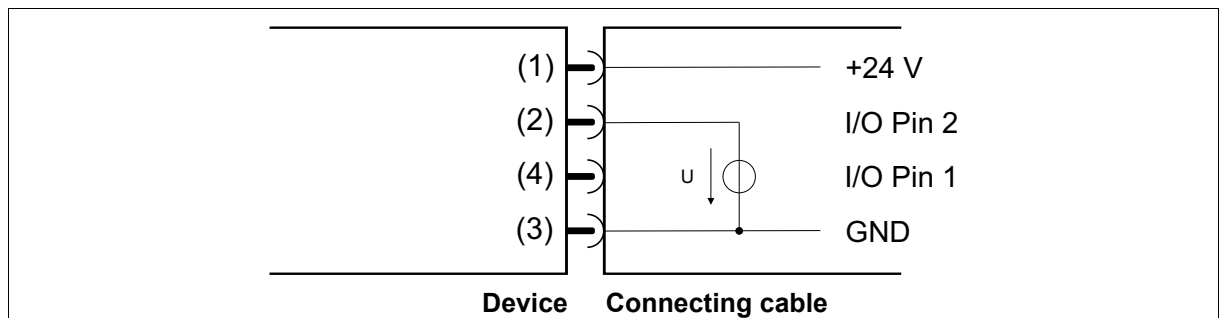

# 6 Electrical connection

## 6.2.2 Analog outputs

I/O Pin 1 and/or I/O Pin 2 can be configured as analog output.

The connection examples for I/O Pin 2 also apply to I/O Pin 1.

### Current output – 4 to 20 mA

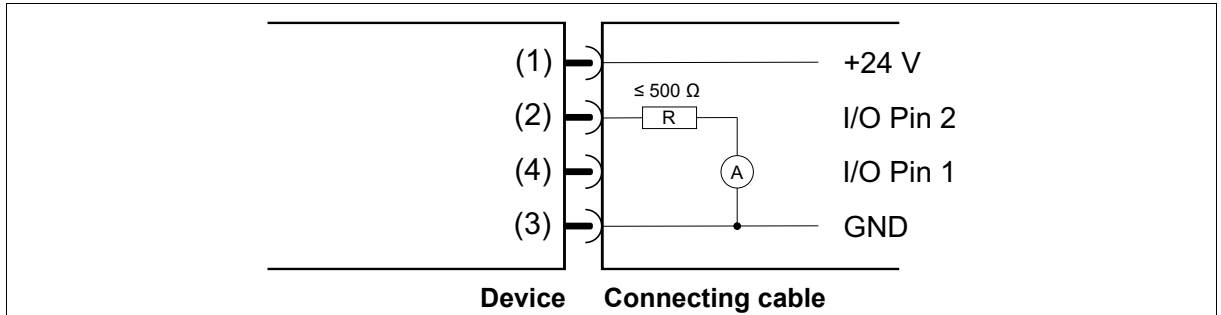

### Voltage output – 0 to 10 V

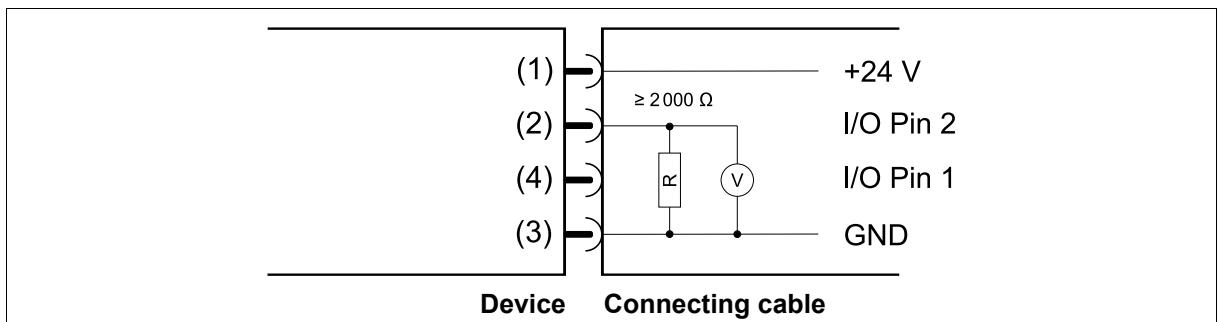

## 6.2.3 Digital outputs

I/O Pin 1 and/or I/O Pin 2 can be configured as digital output.

I/O Pin 1 can be configured as switching or pulse output; I/O Pin 2 can be configured as switching output.

The connection examples for I/O Pin 1 also apply to I/O Pin 2.

### Digital output – push-pull (example 1)

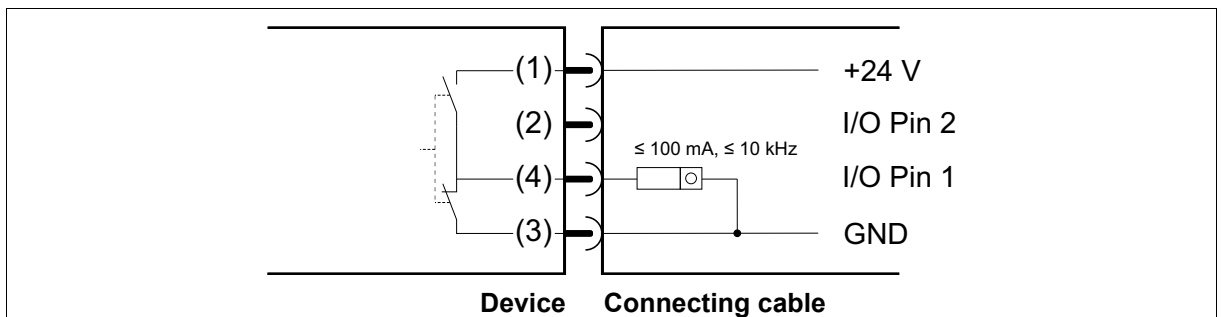

## 6 Electrical connection

### Digital output – push-pull (example 2)

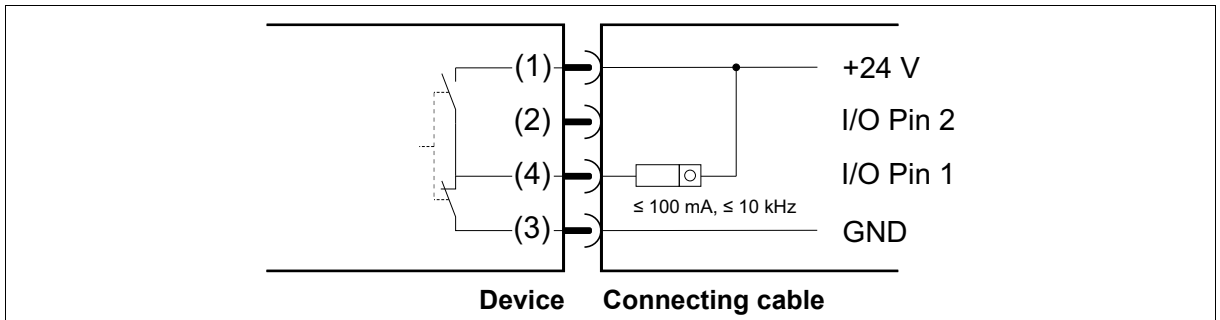

### Digital output – NPN (n-switching)

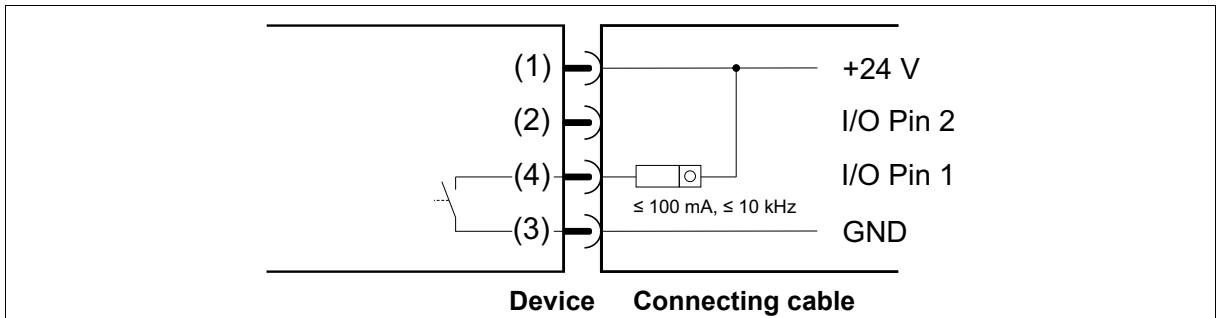

### Digital output – PNP (p-switching)

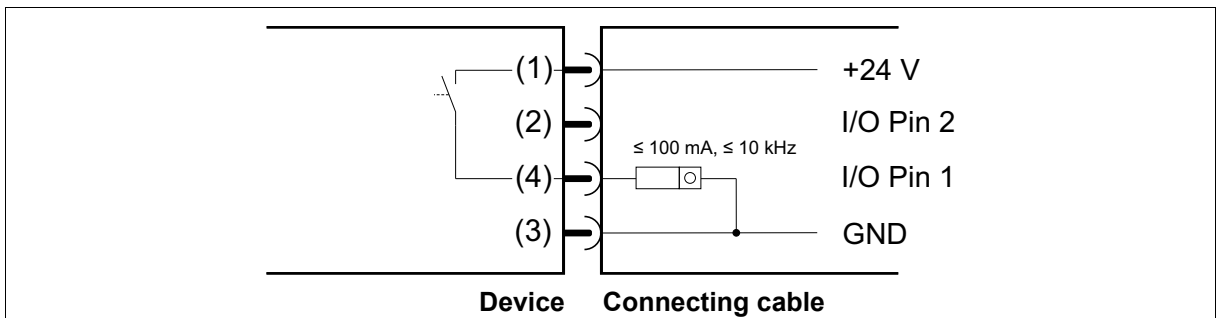

# 6 Electrical connection

## 6.3 Connecting the device

Material	Connecting cable for plug connector M12
----------	---

Requirements:

- The system has been de-energized and secured against being switched on again.
- The connections for grounding, voltage supply and signal processing are professionally prepared.
- The connection cable and the grounding cable are temperature resistant according to the process.
- The connection cable is installed at a minimum distance of 30 cm from high-voltage or high-frequency cables.

Procedure:

1. Screw the grounding wire (1) onto one of the 4 boreholes (2) on the bottom of the case bottom section.

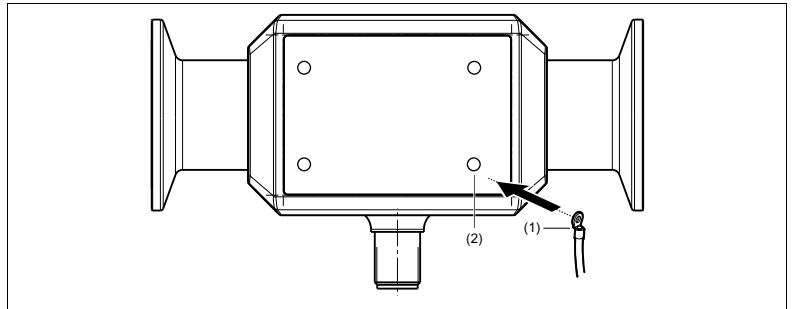

2. Insert the connecting cable (3) into the M12 plug connection (4).

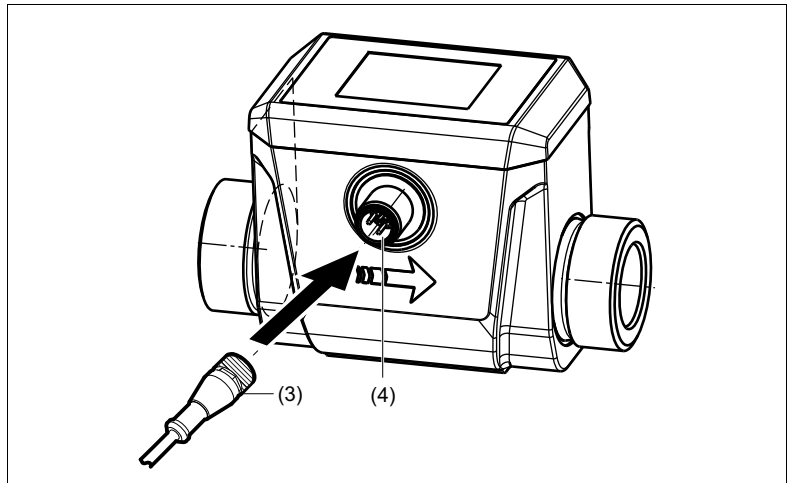

3. Tighten the plug housing (5) on the connecting cable hand-tight.

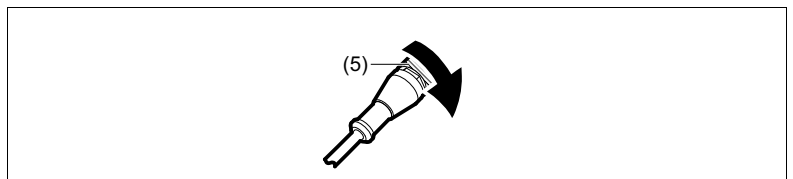

4. Connect the connecting cable to the device that is processing the signals and to the voltage supply.
  5. Lay the connecting cable and the grounding cable<sup>a</sup> so that they are protected from mechanical load.
- <sup>a</sup> Grounding (functional ground) must primarily be carried out when installing in a non-grounded pipe system (e.g. plastic pipes).

The device is ready for operation as soon as the voltage supply is established,  
⇒ "Startup display ", Page 29.

## 7.1 Display elements

### 7.1.1 Startup display

The startup display appears on the display as soon as the voltage supply to the device is established. The startup display switches to the process display after approximately five seconds.

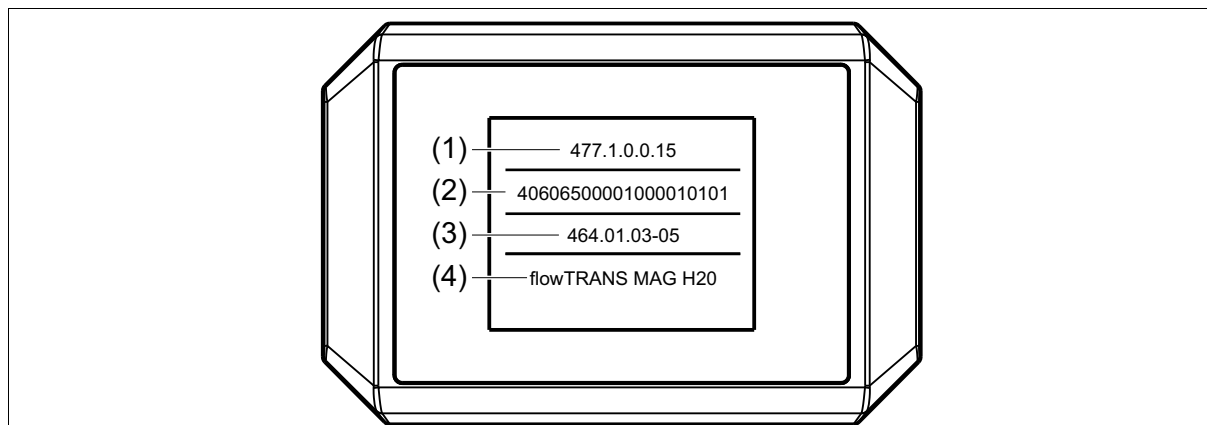

Pos.	Designation	Description
1	<b>Startup display</b>	Shows the device software version.
2		Shows the device hardware version.
3		Shows the Bluetooth® module software version.
4		Shows the device TAG (application-spec. marking).

### 7.1.2 Process display

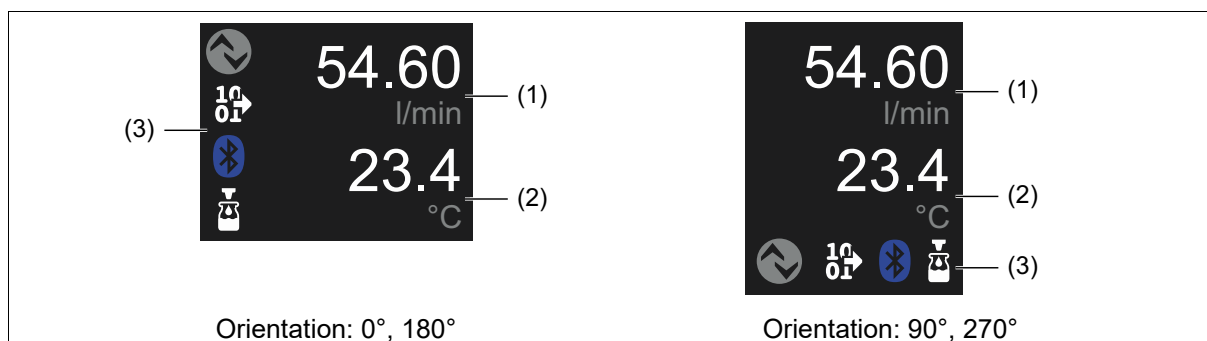



Pos.	Designation	Description
1, 2	<b>Process value 1, Process value 2</b>	Show the following values and messages: <ul style="list-style-type: none"> <li>• Both configured process values (actual values).</li> <li>• The process value system units.</li> <li>• The totalizer for the totalizer function.</li> <li>• The fill volume or remaining volume for the batch function.</li> <li>• Error messages, ⇨ "Troubleshooting ", Page 59</li> </ul>
3	<b>Toolbar</b>	Shows: <ul style="list-style-type: none"> <li>• The configuration and status of I/O pin 1 and I/O pin 2</li> <li>• The configuration and status of the interface connections</li> </ul>

# 7 Operation



## Totalizer, totalizer transmission

Only appears with a correspondingly configured process value.

Pos.	Symbol, display	Description
1		Shows negative count mode of the totalizer.
		Shows positive count mode of the totalizer.
		Shows balanced count mode of the totalizer.

## Batch

Only appears when the process value display is configured accordingly.

Pos.	Symbol, display	Description
1		Shows the fill volume.
		Shows the remaining volume.

## Process value (5-digit)

If the process value exceeds the 5-digit display range, the number of decimal places for the process value is reduced.

Pos.	Symbol, display	Description
2	12345	Shows the positive process value.
	-12345	Shows the negative process value.
	-----	The value -99999 is fallen below or the value +99999 is exceeded.



## System unit



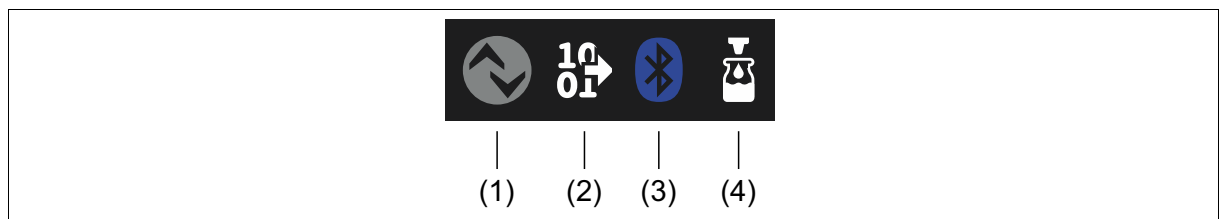

Pos.	Symbol, display	Description
3	l/s, m <sup>3</sup> /h, ft <sup>3</sup> /min, l/min, ft <sup>3</sup> /h, usgal/min, impgal/min, l/h, cm <sup>3</sup> /s, usgal/h, impgal/h, °C, °F	Shows the configured system unit of the process value.

## Toolbar







## Interface connections

Pos.	Symbol, display	Description
1		Interface connection: IO-Link <ul style="list-style-type: none"> <li>Lights up gray when an IO-Link connection is inactive via I/O pin 1.</li> </ul>
		Interface connection: IO-Link <ul style="list-style-type: none"> <li>Lights up white when an IO-Link connection is active via I/O pin 1.</li> </ul>

3		Interface connection: Bluetooth® <ul style="list-style-type: none"> <li>Lights up gray if NFC approval is needed for the connection or if Bluetooth® is permanently disabled.</li> </ul>
	 	Interface connection: Bluetooth® <ul style="list-style-type: none"> <li>Flashes white when Bluetooth® is ready for a connection.</li> </ul>
		Interface connection: Bluetooth® <ul style="list-style-type: none"> <li>Lights up blue when a Bluetooth® connection has been established.</li> </ul>





## I/O pin 1

Shows the configuration, function and status of the device **I/O pin 1**.



Pos.	Symbol, display	Description
1		Configuration: I/O pin 1 ≠ Digital output (switching output) <ul style="list-style-type: none"> <li>Lights up gray when the output is inactive.</li> </ul>
		Configuration: I/O pin 1 = Digital output (switching output) <ul style="list-style-type: none"> <li>Lights up white when the output is active.</li> </ul>
		Configuration: pulse output <ul style="list-style-type: none"> <li>Lights up white when the output is active.</li> </ul>
		Configuration: I/O pin 1 = Analog output <ul style="list-style-type: none"> <li>Lights up white when the output is active.</li> </ul>

## I/O pin 2

Shows the configuration, function and status of the device **I/O pin 2**.

Pos.	Symbol, display	Description
2		Configuration: I/O pin 2 ≠ Digital output (switching output) <ul style="list-style-type: none"> <li>Lights up gray when the output is inactive.</li> </ul>
		Configuration: I/O pin 2 = Digital output (switching output) <ul style="list-style-type: none"> <li>Lights up white when the output is active.</li> </ul>
		Configuration: I/O pin 2 = Analog output <ul style="list-style-type: none"> <li>Lights up white when the output is active.</li> </ul>
		Configuration: Digital input (switching input) <ul style="list-style-type: none"> <li>Lights up gray when the input is inactive.</li> </ul>
		Configuration: Digital input (switching input) <ul style="list-style-type: none"> <li>Lights up white when the input is active.</li> </ul>

## Batch function

Pos.	Symbol, display	Description
4		Lights up gray when the batch function is inactive.
		Lights up white when the batch function is active.

### 7.1.3 Error messages

Error messages and warnings are specified in the text line – alternately with the process display. If there are several error messages, only the error message with the highest priority is displayed.

Further information, ⇒ "Troubleshooting", Page 59.

# 7 Operation

## 7.2 Interfaces

### 7.2.1 Bluetooth

The JUMO smartCONNECT app allows the device to be configured and its parameters to be set using an end device. Configuration data and device information are transmitted via Bluetooth. The Bluetooth radio module of the device is permanently active during initial startup.

The app is available for free download from the [manufacturer's websites](#) or alternatively using the QR code:

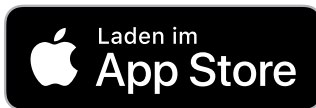
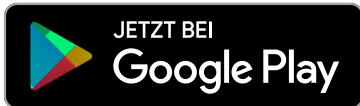

#### Bluetooth® mode

**Active:** The Bluetooth® radio module is permanently active. The device is detected by the smartCONNECT app as soon as it is within range of the Bluetooth® radio module.

**Restricted (via NFC):** The Bluetooth® radio module is inactive and can be temporarily activated via an NFC tag in the device. To establish a connection between the NFC tag and the end device, this device must be NFC-capable and held close to the device display.

**Inactive:** The Bluetooth® radio module can disabled and enabled via IO-Link.

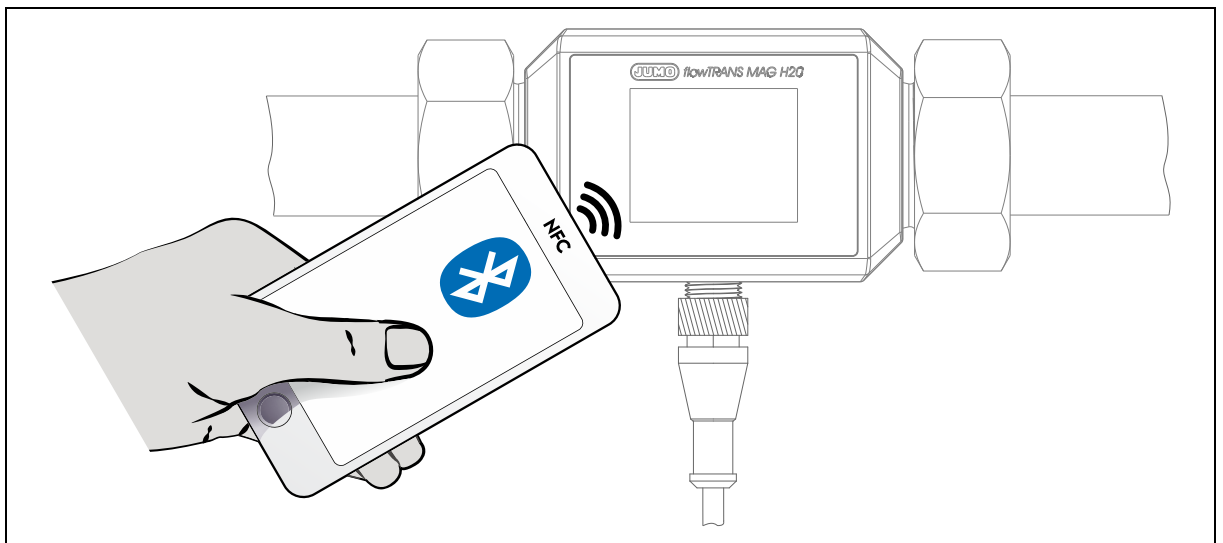

### 7.2.2 IO-Link

IO-Link enables the device to be configured and parameterized using an end device. Process data, configuration data and device information are transmitted using a standard IO-Link master.

The user software of the IO-Link master requires a device description file (IODD) for this, which is assigned to the device ID, ⇒Page 11.

The device IODD collection is available to download for free from the [manufacturer website](#) or alternatively directly via <http://ioddfinder.io-link.com>.

## 8.1 Limit value monitoring

Parameter	Value	Default setting	Description
Function	Inactive Single Point Mode Windows Mode Two Point Mode	Inactive	<b>Inactive:</b> The limit value monitoring function is inactive <b>Single Point Mode:</b> Hysteresis mode ("Switching point SP1" and "Hysteresis") <b>Windows Mode:</b> Windows mode ("Switching point SP1", "Release point SP2" and "Hysteresis") <b>Two Point Mode:</b> Two-point mode ("Switching point SP1" and "Release point SP2")
Logic	High-active Low-active	High-active	The limit value logic can be inverted. <b>High-active:</b> An active limit value monitoring function corresponds to the High signal (logic level 1). <b>Low-active:</b> An active limit value monitoring function corresponds to the Low signal (logic level 0).
Switching point SP1	-150 to +150 l/min	0 l/min	–
	-20 to +90 °C	0 °C	
Switching point SP2	-150 to +150 l/min	0 l/min	Only when "Switching function" = "Windows Mode" and "Two Point Mode"
	-20 to +90 °C	0 °C	
Hysteresis	0 to 150 l/min	0 l/min	Only when "Switching function" = "Single Point Mode" and "Windows Mode"
	0 to +90 °C	0 °C	
Switch-on delay	0 s to 100 s	0 s	The state is only given to the limit value monitoring function output after the time has elapsed.
Switch-off delay	0 s to 100 s	0 s	The state is only given to the limit value monitoring function output after the time has elapsed.
Error behavior	Inactive Active Frozen	Inactive	Behavior of the limit value monitoring function output signal when there is a process value error. <b>Inactive:</b> Inactive signal (logic level 0) <b>Active:</b> Active signal (logic level 1) <b>Frozen:</b> Last valid value

Two limit value monitoring functions are available for each measurand. All limit value monitoring functions can be configured independently of each other.

Different switching modes are selectable, all of which can be inverted. In addition, the limit value monitoring functions have a switching delay.

### Switching delay

A switching delay for switching on and / or switching off can be configured.

If the switching condition is fulfilled, the set timer for the switch-on delay ( $\Delta_{SP1}$ ) starts to elapse. The state is only output after the time has elapsed. If the switching condition is no longer fulfilled before the time has elapsed, the timer is restarted.

The switch-off delay ( $\Delta_{SP2}$ ) works analogously.

The delay times prevent the output from being switched by measured value peaks or by measured value dips.

# 8 Functional descriptions

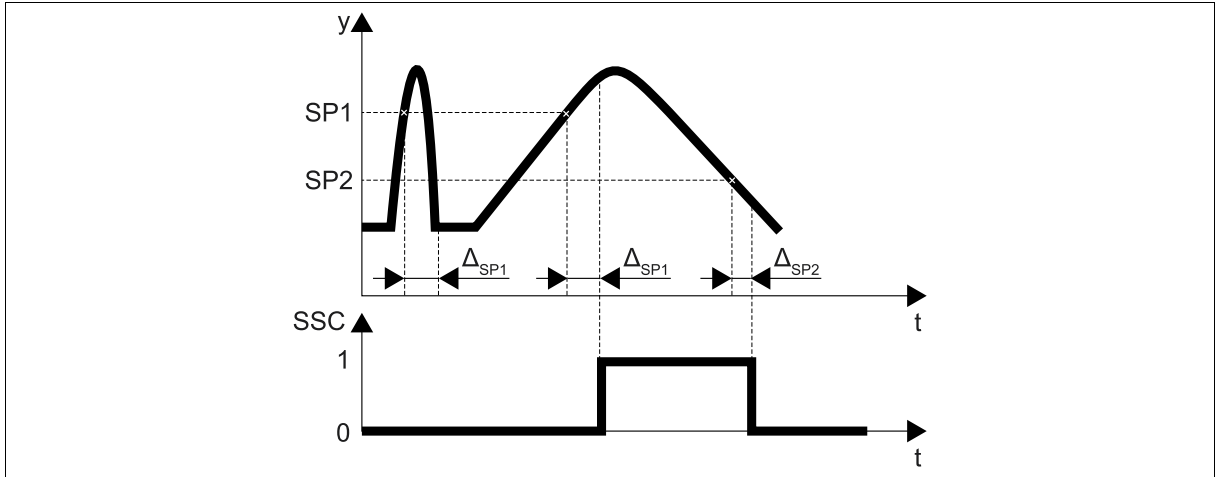

- ( $\Delta_{SP1}$ ) Switch-on delay
- ( $\Delta_{SP2}$ ) Switch-off delay
- (SSC) Limit value monitoring function output signal
- (SP1) Switching point
- (SP2) Release point
- (t) Time
- (y) Measured value

## Hysteresis mode

If the process value exceeds the switching point SP1, the output of the limit value monitoring function becomes active. If the switching point SP1 reduced by the amount of the hysteresis is undershot again, the output of the limit value monitoring function becomes inactive again.

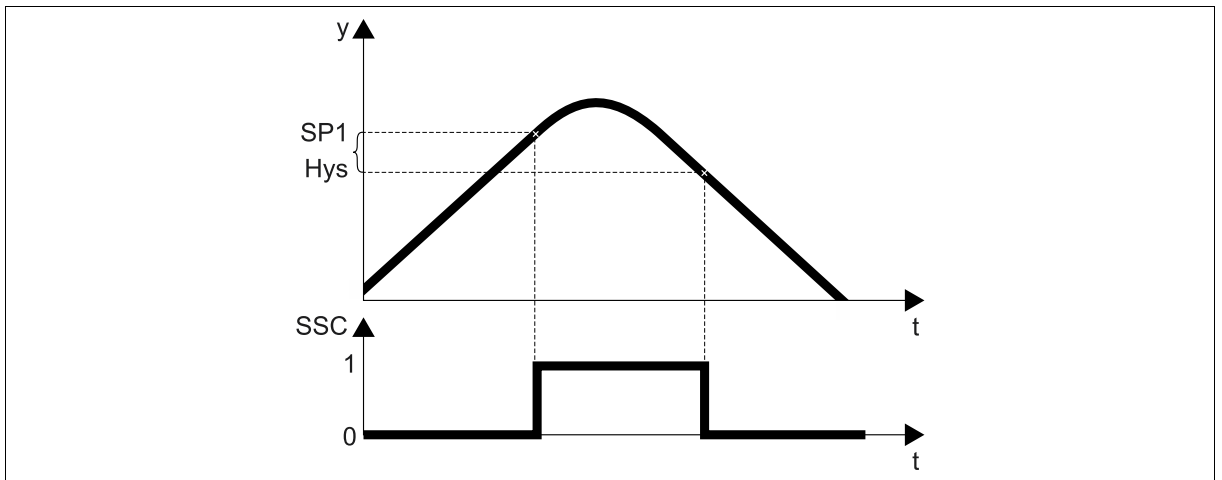

- (SSC) Limit value monitoring function output signal
- (Hys) Hysteresis
- (SP1) Switching point
- (t) Time
- (y) Measured value

## Window mode

Window mode checks whether the process value is within a certain range.  $SP_L$  is defined as the smaller value of switching points SP1 and SP2.  $SP_H$  is defined as the larger value of switching point SP1 and SP2.

The hysteresis of the switching points is adjustable.

## 8 Functional descriptions

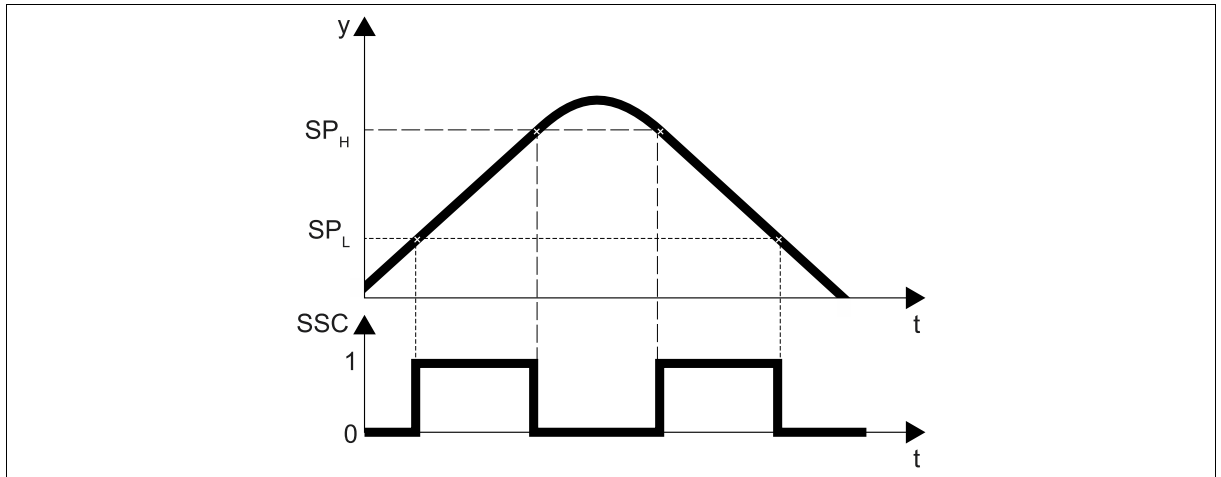

(SSC) Limit value monitoring function output signal  
 ( $t$ ) Time  
 ( $SP_H$ ) High switching point  
 ( $SP_L$ ) Low switching point  
 ( $y$ ) Measured value

### Two-point mode

In two-point mode, two switching points are defined. If the process value exceeds the  $SP_{act}$  switching point, the limit value monitoring function output becomes active. If the process value falls below the  $SP_{inact}$  switching point, the output becomes inactive.

$SP_{act}$  is defined as the larger value of switching points  $SP_1$  and  $SP_2$ ,  $SP_{inact}$  is correspondingly the smaller of the two values.

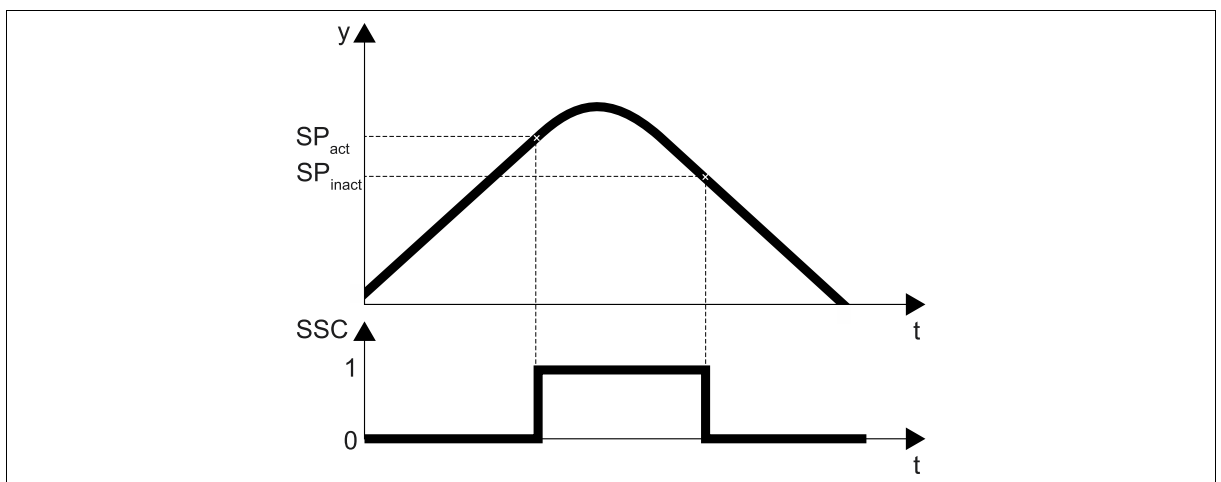

(SSC) Limit value monitoring function output signal  
 ( $t$ ) Time  
 ( $SP_{act}$ ) Active switching point  
 ( $SP_{inact}$ ) Inactive switching point  
 ( $y$ ) Measured value

## 9 Configuration via Bluetooth®

The parameter lists are based on the JUMO smartCONNECT app operating menu. The table headings locate the respective parameters in the app operating menu..

The default settings are shown in **bold** in the following tables.

### 9.1 Device

#### System data

Parameter	Value	Description
Language	Deutsch, <b>English</b> , Français, Español	National language for the process display error messages.
Application-specific marking	<b>flowTRANS MAG H20</b>	TAG designation (text entry with max. 19 characters possible).

#### System units

Parameter	Value	Description
Temperature	°C, °F	System unit for temperature.
Volume	<b>l</b> , cm <sup>3</sup> , m <sup>3</sup> , ft <sup>3</sup> , usgal, impgal	System unit for volume.
Flow	l/s, <b>l/min</b> , l/h, cm <sup>3</sup> /s, m <sup>3</sup> /h, ft <sup>3</sup> /min, ft <sup>3</sup> /h, usgal/min, usgal/h, impgal/min, impgal/h	System unit for flow.

### 9.2 Measurands

#### Flow

Parameter	Value	Description
Fine adjustment	–	–
Simulation	–	–
Filter	–	–
Low flow suppression switching threshold	Input range: 0.00 to 10.00 ( <b>0.15</b> ) %	–
Inversion	<b>Off</b> , On	–

#### Flow > Fine adjustment

Parameter	Value	Description
Function	<b>Inactive</b> , active	Parameter function.
Actual value 0	Input range: -165.00 to 165.00 ( <b>0.00</b> ) l/min	–
Setpoint value 0	Input range: -165.00 to 165.00 ( <b>0.00</b> ) l/min	–
Actual value 1	Input range: -165.00 to 165.00 ( <b>100.00</b> ) l/min	–
Setpoint value 1	Input range: -165.00 to 165.00 ( <b>100.00</b> ) l/min	–

## 9 Configuration via Bluetooth®

### Flow > Simulation

Parameter	Value	Description
Value	Input range: -165.00 to 165.00 (0.00) l/min	Input value for the simulation.
Function	Inactive, active	Function of the parameter. After a device restart, the default setting is always active.

### Flow > Filter

Parameter	Value	Description
Time constant	Input range: 0.0 to 25.0 (1.0) s	Optimization of the measured value update. The higher the filter time constant value, the slower the change in measured value at the output.

### Temperature

Parameter	Value	Description
Offset	Input range: -10.0 to 10.0 (0.0) °C	Offset correction for zero point adjustment.
Simulation	–	–
Filter	–	–

### Temperature > Simulation

Parameter	Value	Description
Value	Input range: -22.0 to 99.0 (0.0) °C	Input value for the simulation.
Function	Inactive, active	Function of the parameter. After a device restart, the default setting is always active.

### Temperature > Filter

Parameter	Value	Description
Time constant	Input range: 0.0 to 25.0 (1.0) s	Optimization of the measured value update. The higher the filter time constant value, the slower the change in measured value at the output.

## 9 Configuration via Bluetooth®

---

### 9.3 Bluetooth

Parameter	Value	Description
Function	Restricted (via NFC), <b>active</b>	Status of the Bluetooth® connection, ⇨ Page32.

### 9.4 Display

#### Appearance

Parameter	Value	Description
Brightness	0 to 10 ( <b>5</b> )	Brightness of the display.
Orientation	<b>0°</b> , 90°, 180°, 270°	Alignment of the display.

#### Process value display > Value 1 (2)

Parameter	Value	Description
–	<b>No selection</b>	Process value is hidden.
Process values	–	Display and configuration of the process value.

#### Process value display > Value 1 (2) > Process values

Parameter	Value	Description
Measurands	Flow, temperature	–
Totalizer	–	–
Batch	Filling volume, residual volume	–

#### Process value display > Value 1 (2) > Process values > Totalizer

Parameter	Value	Description
Totalizer 1	Volume, volume carry	–
Totalizer 2	Volume, volume carry	–

### 9.5 Totalizer

#### Totalizer 1

Parameter	Value	Description
Counting mode	<b>Positive</b> , negative, balanced	Depending on the counting modes, integrate the flow components. Positive: Only positive flow components. Negative: Only negative flow components. Balanced: Positive and negative flow components.

## 9 Configuration via Bluetooth®

### Totalizer 2

Parameter	Value	Description
Counting mode	Positive, negative, <b>balanced</b>	Depending on the counting modes, integrate the flow components. Positive: Only positive flow components. Negative: Only negative flow components. Balanced: Positive and negative flow components.

### 9.6 Batch

Parameter	Value	Description
Volume	Input range: <b>0</b> to 99999000 l	Input value of the volume to be filled in the totalizer system unit.
Max. batch time	Input range: <b>0</b> to 9999	If the input value is exceeded, the batch is aborted.

### 9.7 Limit value monitoring

#### Flow (teach channel 1 (2))

Parameter	Value	Description
Switching point SP1	Input range: -150.00 to 150.00 ( <b>0.00</b> ) l/min	Process value of the limit value monitoring function signal.
Switching point SP2	Input range: -150.00 to 150.00 ( <b>0.00</b> ) l/min	
Logic	<b>High-active</b> , Low-active	–
Function	<b>Inactive</b> , Single Point Mode, Windows Mode, Two Point Mode	–
Hysteresis	Input range: <b>0.00</b> to 150.00 l/min	–
Error behavior 	<b>Inactive</b> , active, frozen	Behavior of the output signal in case of a malfunction.
Switch-on delay	Input range: <b>0.0</b> to 100.0 s	–
Switch-off delay	Input range: <b>0.0</b> to 100.0 s	–

#### Error behavior

**Inactive** value: If the **function** parameter of digital output 1 is configured as a **switching output** value, a process value error sets the **switching output** value to **inactive**.

**Frozen** value: If the **function** parameter of digital output 1 is configured as a **switching output** value, a process value error does not have any influence on the configuration of the **switching output** value.

## 9 Configuration via Bluetooth®

### Flow (teach channel 11 (12))

Parameter	Value	Description
Switching point SP1	Input range: -20.0 to 90.0 (0.0) °C	Process value of the limit value monitoring function signal.
Switching point SP2	Input range: -20.0 to 90.0 (0.0) °C	
Logic	<b>High-active</b> , Low-active	–
Function	<b>Inactive</b> , Single Point Mode, Windows Mode, Two Point Mode	–
Hysteresis	Input range: <b>0.0</b> to 90.0 °C	–
Error behavior 	<b>Inactive</b> , active, frozen	Behavior of the output signal in case of a malfunction.
Switch-on delay	Input range: <b>0.0</b> to 100.0 s	–
Switch-off delay	Input range: <b>0.0</b> to 100.0 s	–

#### Error behavior

**Inactive** value: If the **function** parameter of digital output 1 is configured as a **switching output** value, a process value error sets the **switching output** value to **inactive**.

**Frozen** value: If the **function** parameter of digital output 1 is configured as a **switching output** value, a process value error does not have any influence on the configuration of the **switching output** value.

#### Teach

Parameter	Value	Description
Channel	Input range: 0 to 12 (1)	Selection of the channel that will be addressed by the teach functions.  The teach functions are triggered using 2 system commands. With the teach functions, the current process value is adopted in the respective switching point (SP1, SP2).
System command	65	Teach SP1
	66	Teach SP2
Teach Result	0	Idle
	1	Success Teach SP1
	2	Success Teach SP2
	5	Busy
	7	Error

## 9.8 Analog output

### Analog output 1

Parameter	Value	Description
Output signal	<b>Flow</b> , temperature	–
Output signal type	<b>4 to 20 mA</b> , 0 to 10 V	Parameter output signal.
Scale start	Input range: -1650.0 to 1650.0 ( <b>0.0</b> ) l/min, -99.0 to 99.0 °C	Process value for the current output (4 mA) or the voltage output (0 V).
Scale end	Input range: -1650.0 to 1650.0 (DN 06: <b>5</b> , DN 15: <b>35</b> , DN 20: <b>75</b> , DN 25: <b>150</b> ) l/min, -99.0 to 99.0 °C	Process value for the current output (20 mA) or the voltage output (10 V).
Error behavior	<b>Replacement value</b> , low, high	Output signal in the event of a malfunction: Replacement value: Input value for the parameter <b>replacement value</b> . Low: 3.4 mA or 0 V High: 22 mA or 11 V
Replacement value	Input range: <b>3.4</b> to 22 mA, 0 to 11 V	<b>Error behavior</b> parameter must be configured as a <b>replacement value</b> .

### Analog output 1 > Output signal

Parameter	Value	Description
Process values	–	–

### Analog output 1 > Output signal > Process values

Parameter	Value	Description
Measurands	Flow, temperature	–

### Analog output 2

Parameter	Value	Description
Output signal	Flow, <b>temperature</b>	–
Output signal type	<b>4 to 20 mA</b> , 0 to 10 V	Parameter output signal.
Scale start	Input range: -1650.0 to 1650.0 l/min, -99.0 to 99.0 ( <b>-20.0</b> ) °C	Process value for the current output (4 mA) or the voltage output (0 V).
Scale end	Input range: -1650.0 to 1650.0 l/min, -99.0 to 99.0 ( <b>90.0</b> ) °C	Process value for the current output (20 mA) or the voltage output (10 V).

## 9 Configuration via Bluetooth®

Parameter	Value	Description
Error behavior	Replacement value, low, high	Output signal in the event of a malfunction: Replacement value: Input value for the parameter <b>replacement value</b> . Low: 3.4 mA or 0 V High: 22 mA or 11 V
Replacement value	Input range: 3.4 to 22 mA, 0 to 11 V	<b>Error behavior</b> parameter must be configured as a <b>replacement value</b> .

### Analog output 2 > Output signal

Parameter	Value	Description
Process values	–	–

### Analog output 2 > Output signal > Process values

Parameter	Value	Description
Measurands	Flow, temperature	–

## 9.9 Digital output

### Digital output 1 (2)

Parameter	Value	Description
Output signal	–	–
Inversion	Off, On	Inverts the output signal.
Output signal type	Push-pull, n-switching, p-switching	Parameter function.

### Digital output 1 (2) > Output signal

Parameter	Value	Description
Process values	–	–

### Digital output 1 (2) > Output signal > Process values

Parameter	Value	Description
Limit value monitoring function	–	–
Batch	Batch active, batch error	–
Alarm overview	–	–

### Digital output 1 (2) > Output signal > Process values > Alarm overview

Parameter	Value	Description
Collective alarm	Device failure	–

### Digital output 1 (2) > Output signal > Process values > Limit value monitoring function

Parameter	Value	Description
Flow (teach channel 1)	Output	–
Flow (teach channel 2)	Output	–

## 9 Configuration via Bluetooth®

Parameter	Value	Description
Flow (teach channel 11)	Output	–
Flow (teach channel 12)	Output	–

### 9.10 IO-Link

#### I/O pin 1 (C/Q)

Parameter	Value	Description
Function	Inactive, <b>IO-Link</b> , digital output, pulse output, analog output	Parameter function.

#### I/O pin 2 (DI/DQ)

Parameter	Value	Description
Function	Inactive, digital output, <b>digital input</b> , analog output	Parameter function.

#### Identification

Parameter	Value	Description
Plant identification code	***	TAG designation (text entry with max. 32 characters possible).
Location identification code	***	

### 9.11 Digital input

#### Application

Parameter	Value	Description
Function	<b>Inactive</b> , reset all totalizers, start/stop batch, measured value suppression	Function of the parameter in the event of signaling at the digital input.

#### General information

Parameter	Value	Description
Inversion	<b>Off</b> , On	Inverts the input signal.

### 9.12 Pulse output

Parameter	Value	Description
Volume unit	cm <sup>3</sup> , l, m <sup>3</sup> , ft <sup>3</sup> , usgal, impgal	System unit for volume.
Pulses per unit	Input range: 1 to 120000 (DN 06: <b>120000</b> , DN 15: <b>17100</b> , DN 20: <b>8000</b> , DN 25: <b>4000</b> )	Output value in pulses per volume unit (system unit of the volume parameter).

# 10 Configuration via IO-Link

The default settings are shown in **bold** in the following tables.

## 10.1 Device

### System data

Parameter	Value	Description	Index	Sub-index	Data type	Access right <sup>a</sup>
Language	Deutsch, <b>English</b> , Français, Español	National language for the process display error messages.	500	1	Uint8	RW
Application-specific marking	<b>flowTRANS MAG H20</b>	TAG designation (text entry with max. 19 characters possible).	24	0	String	RW

<sup>a</sup> RW = Read and write access, RO = Read-only access, WO = Write-only access

### System units

Parameter	Value	Description	Index	Sub-index	Data type	Access right <sup>a</sup>
Temperature	°C, °F	System unit for temperature.	500	4	Uint8	RW
Volume	l, cm <sup>3</sup> , m <sup>3</sup> , ft <sup>3</sup> , usgal, impgal	System unit for volume.	500	3	Uint8	RW
Flow	l/s, <b>l/min</b> , l/h, cm <sup>3</sup> /s, m <sup>3</sup> /h, ft <sup>3</sup> /min, ft <sup>3</sup> /h, usgal/min, usgal/h, impgal/min, impgal/h	System unit for flow.	500	2	Uint8	RW

<sup>a</sup> RW = Read and write access, RO = Read-only access, WO = Write-only access

## 10.2 Measurands

### Flow

Parameter	Value	Description	Index	Sub-index	Data type	Access right <sup>a</sup>
Low flow suppression switching threshold	Input range: 0.00 to 10.00 (0.15) %	–	100	1	Float	RW
Inversion	Off, On	–	100	4	Boolean	RW

<sup>a</sup> RW = Read and write access

### Flow > Fine adjustment

Parameter	Value	Description	Index	Sub-index	Data type	Access right <sup>a</sup>
Function	Inactive, active	Parameter function.	110	1	Uint8	RW
Actual value 0	Input range: -165.00 to 165.00 (0.00) l/min	–	110	2	Float	RW
Setpoint value 0	Input range: -165.00 to 165.00 (0.00) l/min	–	110	4	Float	RW
Actual value 1	Input range: -165.00 to 165.00 (100.00) l/min	–	110	3	Float	RW
Setpoint value 1	Input range: -165.00 to 165.00 (100.00) l/min	–	110	5	Float	RW

<sup>a</sup> RW = Read and write access

### Flow > Simulation

Parameter	Value	Description	Index	Sub-index	Data type	Access right <sup>a</sup>
Value	Input range: -165.00 to 165.00 (0.00) l/min	Input value for the simulation.	100	3	Float	RW
Function	Inactive, active	Function of the parameter. After a device restart, the default setting is always active.	580	1	Action	WO

<sup>a</sup> RW = Read and write access, WO = Write-only access

# 10 Configuration via IO-Link

## Flow > Filter

Parameter	Value	Description	Index	Sub-index	Data type	Access right <sup>a</sup>
Time constant	Input range: 0.0 to 25.0 (1.0) s	Optimization of the measured value update. The higher the filter time constant value, the slower the change in measured value at the output.	100	2	Float	RW

<sup>a</sup> RW = Read and write access

## Temperature

Parameter	Value	Description	Index	Sub-index	Data type	Access right <sup>a</sup>
Offset	Input range: -10.0 to 10.0 (0.0) °C	Offset correction for zero point adjustment.	120	1	Float	RW

<sup>a</sup> RW = Read and write access

## Temperature > Simulation

Parameter	Value	Description	Index	Sub-index	Data type	Access right <sup>a</sup>
Value	Input range: -22.0 to 99.0 (0.0) °C	Input value for the simulation.	120	3	Float	RW
Function	Inactive, active	Function of the parameter. After a device restart, the default setting is always active.	581	0	Uint8	WO

<sup>a</sup> RW = Read and write access, WO = Write-only access

## Temperature > Filter

Parameter	Value	Description	Index	Sub-index	Data type	Access right <sup>a</sup>
Time constant	Input range: 0.0 to 25.0 (1.0) s	Optimization of the measured value update. The higher the filter time constant value, the slower the change in measured value at the output.	120	2	Float	RW

<sup>a</sup> RW = Read and write access

## 10.3 Bluetooth

Parameter	Value	Description	Index	Sub-index	Data type	Access right <sup>a</sup>
Function	Inactive, restricted (via NFC), <b>Active</b>	Status of the Bluetooth® connection, ⇨ Seite 32.	560	1	Uint8	RW

<sup>a</sup> RW = Read and write access

## 10.4 Display

### Appearance

Parameter	Value	Description	Index	Sub-index	Data type	Access right <sup>a</sup>
Brightness	0 to 10 (5)	Brightness of the display.	540	1	Uint32	RW
Orientation	0°, 90°, 180°, 270°	Alignment of the display.	540	2	Uint8	RW

<sup>a</sup> RW = Read and write access, RO = Read-only access, WO = Write-only access

### Process value display > Value 1 > Process values

Parameter	Value	Description	Index	Sub-index	Data type	Access right <sup>a</sup>
-	No selection	-	540	3	Uint8	RW
Measurands	Flow, temperature					
Totalizer 1	Volume, volume carry					
Totalizer 2	Volume, volume carry					
Batch	Filling volume, residual volume					

<sup>a</sup> RW = Read and write access, RO = Read-only access, WO = Write-only access

# 10 Configuration via IO-Link

## Process value display > Value 2 > Process values

Parameter	Value	Description	Index	Sub-index	Data type	Access right <sup>a</sup>
-	No selection	-	540	4	Uint8	RW
Measurands	Flow, temperature					
Totalizer 1	Volume, volume carry					
Totalizer 2	Volume, volume carry					
Batch	Filling volume, residual volume					

<sup>a</sup> RW = Read and write access, RO = Read-only access, WO = Write-only access

## 10.5 Totalizer

### Totalizer 1

Parameter	Value	Description	Index	Sub-index	Data type	Access right <sup>a</sup>
Counting mode	Positive, negative, balanced	Depending on the counting modes, integrate the flow components. Positive: Only positive flow components. Negative: Only negative flow components. Balanced: Positive and negative flow components.	340	1	Uint8	RW

<sup>a</sup> RW = Read and write access

### Totalizer 2

Parameter	Value	Description	Index	Sub-index	Data type	Access right <sup>a</sup>
Counting mode	Positive, negative, <b>balanced</b>	Depending on the counting modes, integrate the flow components. Positive: Only positive flow components. Negative: Only negative flow components. Balanced: Positive and negative flow components.	360	1	Uint8	RW

<sup>a</sup> RW = Read and write access

## 10.6 Batch

Parameter	Value	Description	Index	Sub-index	Data type	Access right <sup>a</sup>
Volume	Input range: <b>0</b> to 99999000 l	Input value of the volume to be filled in the totalizer system unit.	380	1	Float	RW
Max. batch time	Input range: <b>0</b> to 9999	If the input value is exceeded, the batch is aborted.	380	2	Uint32	RW

<sup>a</sup> RW = Read and write access

## 10.7 Limit value monitoring

### Flow (teach channel 1)

Parameter	Value	Description	Index	Sub-index	Data type	Access right <sup>a</sup>
Switching point SP1	Input range: -150.00 to 150.00 ( <b>0.00</b> ) l/min	Process value of the limit value monitoring function signal.	60	1	Float	RW
Switching point SP2	Input range: -150.00 to 150.00 ( <b>0.00</b> ) l/min		60	2	Float	RW
Logic	<b>High-active</b> , Low-active	-	61	1	Uint8	RW
Function	<b>Inactive</b> , Single Point Mode, Windows Mode, Two Point Mode	-	61	2	Uint8	RW
Hysteresis	Input range: <b>0.00</b> to 150.00 l/min	-	61	3	Float	RW
Error behavior 	<b>Inactive</b> , active, frozen	Behavior of the output signal in case of a malfunction.	77	1	Uint8	RW
Switch-on delay	Input range: <b>0.0</b> to 100.0 s	-	77	2	Float	RW
Switch-off delay	Input range: <b>0.0</b> to 100.0 s	-	77	3	Float	RW

<sup>a</sup> RW = Read and write access

### Error behavior

**Inactive** value: If the **function** parameter of digital output 1 is configured as a **switching output** value, a process value error sets the **switching output** value to **inactive**.

**Frozen** value: If the **function** parameter of digital output 1 is configured as a **switching output** value, a process value error does not have any influence on the configuration of the **switching output** value.

# 10 Configuration via IO-Link

## Flow (teach channel 2)

Parameter	Value	Description	Index	Sub-index	Data type	Access right <sup>a</sup>
Switching point SP1	Input range: -150.00 to 150.00 <b>(0.00)</b> l/min	Process value of the limit value monitoring function signal.	62	1	Float	RW
Switching point SP2	Input range: -150.00 to 150.00 <b>(0.00)</b> l/min					
Logic	<b>High-active</b> , Low-active	-	62	1	Uint8	RW
Function	<b>Inactive</b> , Single Point Mode, Windows Mode, Two Point Mode	-	63	2	Uint8	RW
Hysteresis	Input range: <b>0.00</b> to 150.00 l/min	-	63	3	Float	RW
Error behavior 	<b>Inactive</b> , active, frozen	Behavior of the output signal in case of a malfunction.	79	1	Uint8	RW
Switch-on delay	Input range: <b>0.0</b> to 100.0 s	-	79	2	Float	RW
Switch-off delay	Input range: <b>0.0</b> to 100.0 s	-	79	3	Float	RW

<sup>a</sup> RW = Read and write access

### Error behavior

**Inactive** value: If the **function** parameter of digital output 1 is configured as a **switching output** value, a process value error sets the **switching output** value to **inactive**.

**Frozen** value: If the **function** parameter of digital output 1 is configured as a **switching output** value, a process value error does not have any influence on the configuration of the **switching output** value.

## Temperature (teach channel 11)

Parameter	Value	Description	Index	Sub-index	Data type	Access right <sup>a</sup>
Switching point SP1	Input range: -20.0 to 90.0 <b>(0.0)</b> °C	Process value of the limit value monitoring function signal.	16396	1	Float	RW
Switching point SP2	Input range: -20.0 to 90.0 <b>(0.0)</b> °C					
Logic	<b>High-active</b> , Low-active	-	16397	1	Uint8	RW
Function	<b>Inactive</b> , Single Point Mode, Windows Mode, Two Point Mode	-	16397	2	Uint8	RW
Hysteresis	Input range: <b>0.0</b> to 90.0 °C	-	16397	3	Float	RW

Parameter	Value	Description	Index	Sub-index	Data type	Access right <sup>a</sup>
Error behavior 	Inactive, active, frozen	Behavior of the output signal in case of a malfunction.	16141	1	Uint8	RW
Switch-on delay	Input range: 0.0 to 100.0 s	–	16141	2	Float	RW
Switch-off delay	Input range: 0.0 to 100.0 s	–	16141	3	Float	RW

<sup>a</sup> RW = Read and write access

### Error behavior

**Inactive** value: If the **function** parameter of digital output 1 is configured as a **switching output** value, a process value error sets the **switching output** value to **inactive**.

**Frozen** value: If the **function** parameter of digital output 1 is configured as a **switching output** value, a process value error does not have any influence on the configuration of the **switching output** value.

### Temperature (teach channel 12)

Parameter	Value	Description	Index	Sub-index	Data type	Access right <sup>a</sup>
Switching point SP1	Input range: -20.0 to 90.0 (0.0) °C	Process value of the limit value monitoring function signal.	16398	1	Float	RW
Switching point SP2	Input range: -20.0 to 90.0 (0.0) °C			2	Float	RW
Logic	<b>High-active</b> , Low-active	–	16399	1	Uint8	RW
Function	<b>Inactive</b> , Single Point Mode, Windows Mode, Two Point Mode	–	16399	2	Uint8	RW
Hysteresis	Input range: 0.0 to 90.0 °C	–	16399	3	Float	RW
Error behavior 	<b>Inactive</b> , active, frozen	Behavior of the output signal in case of a malfunction.	16143	1	Uint8	RW
Switch-on delay	Input range: 0.0 to 100.0 s	–	16143	2	Float	RW
Switch-off delay	Input range: 0.0 to 100.0 s	–	16143	3	Float	RW

<sup>a</sup> RW = Read and write access

### Error behavior

**Inactive** value: If the **function** parameter of digital output 1 is configured as a **switching output** value, a process value error sets the **switching output** value to **inactive**.

# 10 Configuration via IO-Link

**Frozen value:** If the **function** parameter of digital output 1 is configured as a **switching output** value, a process value error does not have any influence on the configuration of the **switching output** value.

## Teach

Parameter	Value	Description	Index	Sub-index	Data type	Access right <sup>a</sup>
Channel	Input range: 0 to 12 (1)	Selection of the channel that will be addressed by the teach functions. The teach functions are triggered using 2 system commands. With the teach functions, the current process value is adopted in the respective switching point (SP1, SP2).	58	0	Uint8	RW
System command	65	Teach SP1	2	0	Uint8	WO
	66	Teach SP2	2	0	Uint8	WO
Teach Result	0	Idle	59	0	Bool	RO
	1	Success Teach SP1				
	2	Success Teach SP2				
	5	Busy				
	7	Error				

<sup>a</sup> RW = Read and write access, RO = Read-only access, WO = Write-only access

## 10.8 Analog output

### Analog output 1

Parameter	Value	Description	Index	Sub-index	Data type	Access right <sup>a</sup>
Output signal	Flow, temperature	–	260	1	Uint8	RW
Output signal type	4 to 20 mA, 0 to 10 V	Parameter output signal.	260	2	Uint8	RW
Scale start	Input range: -1650.0 to 1650.0 (0.0) l/min, -99.0 to 99.0 °C	Process value for the current output (4 mA) or the voltage output (0 V).	260	3	Float	RW
Scale end	Input range: -1650.0 to 1650.0 (DN 06: 5, DN 15: 35, DN 20: 75, DN 25: 150) l/min, -99.0 to 99.0 °C	Process value for the current output (20 mA) or the voltage output (10 V).	260	4	Float	RW
Error behavior	Replacement value, low, high	Output signal in the event of a malfunction: Replacement value: Input value for the parameter <b>replacement value</b> . Low: 3.4 mA or 0 V High: 22 mA or 11 V	260	5	Uint8	RW
Replacement value	Input range: 3.4 to 22 mA, 0 to 11 V	<b>Error behavior</b> parameter must be configured as a <b>replacement value</b> .	260	6	Float	RW

<sup>a</sup> RW = Read and write access, RO = Read-only access, WO = Write-only access

# 10 Configuration via IO-Link

## Analog output 2

Parameter	Value	Description	Index	Sub-index	Data type	Access right <sup>a</sup>
Output signal	Flow, <b>temperature</b>	-	280	1	Uint8	RW
Output signal type	<b>4 to 20 mA</b> , 0 to 10 V	Parameter output signal.	280	2	Uint8	RW
Scale start	Input range: -1650.0 to 1650.0 l/min, -99.0 to 99.0 (- <b>20.0</b> ) °C	Process value for the current output (4 mA) or the voltage output (0 V).	280	3	Float	RW
Scale end	Input range: -1650.0 to 1650.0 l/min, -99.0 to 99.0 ( <b>90.0</b> ) °C	Process value for the current output (20 mA) or the voltage output (10 V).	280	4	Float	RW
Error behavior	<b>Replacement value</b> , low, high	Output signal in the event of a malfunction: Replacement value: Input value for the parameter <b>replacement value</b> . Low: 3.4 mA or 0 V High: 22 mA or 11 V	280	5	Uint8	RW
Replacement value	Input range: <b>3.4 to 22 mA</b> , 0 to 11 V	<b>Error behavior</b> parameter must be configured as a <b>replacement value</b> .	280	6	Float	RW

<sup>a</sup> RW = Read and write access, RO = Read-only access, WO = Write-only access

## 10.9 Digital output

### Digital output 1

Parameter	Value	Description	Index	Sub-index	Data type	Access right <sup>a</sup>
Limit value monitoring function	<b>Flow (teach channel 1)</b> , Flow (teach channel 2), Temperature (teach channel 11), Temperature (teach channel 12)	–	200	1	Uint8	RW
Batch	Batch active, batch error					
Alarm overview	Collective alarm					
Inversion	<b>Off, On</b>	Inverts the output signal.	200	2	Uint8	RW
Output signal type	<b>Push-pull</b> , n-switching, p-switching	Parameter function.	200	3	Uint8	RW

<sup>a</sup> RW = Read and write access, RO = Read-only access, WO = Write-only access

### Digital output 2

Parameter	Value	Description	Index	Sub-index	Data type	Access right <sup>a</sup>
Limit value monitoring function	Flow (teach channel 1), <b>Flow (teach channel 2)</b> , Temperature (teach channel 11), Temperature (teach channel 12)	–	220	1	Uint8	RW
Batch	Batch active, batch error					
Alarm overview	Collective alarm					
Inversion	<b>Off, On</b>	Inverts the output signal.	220	2	Uint8	RW
Output signal type	<b>Push-pull</b> , n-switching, p-switching	Parameter function.	220	3	Uint8	RW

<sup>a</sup> RW = Read and write access, RO = Read-only access, WO = Write-only access

# 10 Configuration via IO-Link

## 10.10 IO-Link

### I/O pin 1 (C/Q)

Parameter	Value	Description	Index	Sub-index	Data type	Access right <sup>a</sup>
Function	Inactive, <b>IO-Link</b> , digital output, pulse output, analog output	Parameter function.	520	1	Uint8	RW

<sup>a</sup> RW = Read and write access

### I/O pin 2 (DI/DQ)

Parameter	Value	Description	Index	Sub-index	Data type	Access right <sup>a</sup>
Function	Inactive, digital output, <b>digital input</b> , analog output	Parameter function.	521	1	Uint8	RW

<sup>a</sup> RW = Read and write access

### Identification

Parameter	Value	Description	Index	Sub-index	Data type	Access right <sup>a</sup>
Plant identification code	***	TAG designation (text entry with max. 32 characters possible).	25	0	String	RW
Location identification code	***		26	0	String	RW

<sup>a</sup> RW = Read and write access

## 10.11 Digital input

### Application

Parameter	Value	Description	Index	Sub-index	Data type	Access right <sup>a</sup>
Function	Inactive, reset all totalizers, start/stop batch, measured value suppression	Function of the parameter in the event of signaling at the digital input.	300	2	Uint8	RW

<sup>a</sup> RW = Read and write access

### General information

Parameter	Value	Description	Index	Sub-index	Data type	Access right <sup>a</sup>
Inversion	Off, On	Inverts the input signal.	300	1	Uint8	RW

<sup>a</sup> RW = Read and write access

## 10.12 Pulse output

Parameter	Value	Description	Index	Sub-index	Data type	Access right <sup>a</sup>
Volume unit	cm <sup>3</sup> , l, m <sup>3</sup> , ft <sup>3</sup> , usgal, impgal	System unit for volume.	400	2	Uint8	RW
Pulses per unit	Input range: 1 to 120000 (DN 06: <b>120000</b> , DN 15: <b>17100</b> , DN 20: <b>8000</b> , DN 25: <b>4000</b> )	Output value in pulses per volume unit (system unit of the volume parameter).	400	1	Int32	RW

<sup>a</sup> RW = Read and write access

# 11 Cyclic data transfer via IO-Link

The data is transferred in a cycle via the IO-Link interface to the IO-Link Master (PDI = Process Data Input). All the process data can be extracted via index 40 and subindex 0.

Bit offset	48	16	4	3	2	1	0
Data type	Float32T	Float32T	Integer12T	Bool	Bool	Bool	Bool
Parameter	MDC <sup>a</sup> 1: Flow	MDC <sup>a</sup> 2: Temperature	Bit offset 4: Invalid flow Bit offset 5: Invalid temperature Bit offset 6: Active batch Bit offset 7: Batch error Bit offset 8: Invalid configuration Bit offset 9: Invalid calibration data	SSC <sup>b</sup> 2.2	SSC <sup>b</sup> 2.1	SSC <sup>b</sup> 1.2	SSC <sup>b</sup> 1.1

<sup>a</sup> Measuring Data Channel: Function class for measured values with a fixed set of attributes that define the measurement and precise description of the values within the process data.

<sup>b</sup> Switching Signal Channel, ⇨ Page 33.

## 12.1 Process value error

Process value errors are displayed flashing instead of the process value. In part, process value errors are supplemented with error messages by symbols and a two-line message – always alternating with the basic status.

Appearance	Cause	Remedy
-----	The input value is invalid. The sensor is defective or communication to the sensor is impaired.	Contact the manufacturer.
	There is an internal device error.	Contact the manufacturer.
<<<<<	The measuring range was undershot.	Operate the device within the device specifications. If necessary, contact the manufacturer.
>>>>>	The measuring range was exceeded.	Operate the device within the device specifications. If necessary, contact the manufacturer.

# 12 Troubleshooting

## 12.2 Error messages in line with NAMUR

Error messages according to NAMUR classification NE 107 are displayed by symbols and a two-line message (alternating with the process display).

Symbol	Designation					
	<b>Error/failure</b>					
Error message	Cause	Remedy	Bit offset for status in PDI	Event code	Event type	
Configuration faulty	The checksum of the configuration data is faulty.	Transfer the configuration data to the device again.	8	0x6320	Error	
Service data faulty	The process data partition is faulty.	Transfer the configuration data to the device again.	8	0x6320	Error	
Calibration data faulty	The checksum of the calibration data is faulty.	Contact the manufacturer.	9	0x5000	Error	
Device not calibrated	There is no calibration data.	Contact the manufacturer.	9	0x5000	Error	
Sensor communication	The communication to the sensor is impaired.	Contact the manufacturer.		0x1000	Error	
Flow faulty	The flow sensor has failed. Either the flow is too high or the sensor is defective.	Contact the manufacturer.	4	0x8C20	Error	
Temperature faulty	The temperature sensor has failed. There may be a short circuit.	Contact the manufacturer.	5	0x8C20	Error	
The sensor is faulty	The device is faulty.	Contact the manufacturer.	–	0x5000	Error	

<b>Symbol</b>	<b>Designation</b>
	<b>Functional check</b>

<b>Error message</b>	<b>Cause</b>	<b>Remedy</b>	<b>Bit offset for status in PDI</b>	<b>Event code</b>	<b>Event type</b>
Simulation active	Simulation mode is active.	Deactivate simulation mode or restart the device.	–	0x8C01	Warning

<b>Symbol</b>	<b>Designation</b>
	<b>Outside the specification</b>

<b>Error message</b>	<b>Cause</b>	<b>Remedy</b>	<b>Bit offset for status in PDI</b>	<b>Event code</b>	<b>Event type</b>
Device operating conditions	The device is being operated outside the device specifications.	Operate the device within the device specifications.	–	–	–
Temperature accuracy	The device is operated outside the specified range.	Operate the device within the device specifications.	–	0x8C10	Warning
Flow accuracy	The device is operated outside the specified range.	Operate the device within the device specifications.	–	0x8C10	Warning
Undervoltage	The voltage supply to the device is insufficient.	Check the voltage supply to the device.	–	0x5111	Warning
Overload at C/Q or DO	The switching outputs are overloaded.	Check the connection and load of the switching outputs.	–	–	–
Analog output error	The burden at the analog output is too high.	Observe the specified values for the burden of the analog output.	–	–	–

# 12 Troubleshooting

## 12.3 Error messages outside NAMUR

Error messages outside NAMUR classification NE 107 and additional information are displayed by symbols and a two-line message (alternating with the process display).

Symbol	Designation
	Caution

Error message	Cause	Remedy	Bit offset for status in PDI	Event code	Event type
Restart the device	The device must be restarted.	Restart the device.	–	–	–

Symbol	Designation
	Alarm

Error message	Cause	Remedy	Bit offset for status in PDI	Event code	Event type
Batch error	The maximum batch time has been exceeded or there is a process value error.	Check the filling volume of the batch and restart the function.	7	0x8CA1	Warning

## 13.1 Cleaning device housing

The device housing can be cleaned when the device has been installed.

Clean the device with a cloth dampened with water.

## 13.2 Decontamination

Use:

- When the medium is changed in the plant.
- Before replacing sealing rings/O-rings.
- Before returning the device.
- Before disposing of the device.

Requirements:

- The device is uninstalled, ⇒ Page 64.
- If the medium is a hazardous substance: The information in the safety data sheet is taken into account.
- Suitable protective equipment has been set up.
- Ein geeignetes Reinigungsmittel ist einsatzbereit.
- Ein Reinigungsplatz zum Spülen und Neutralisieren aller medienberührten Teile ist vorbereitet.

Procedure:

1. **CAUTION!** Do not damage the sealing ring grooves when removing the sealing rings/O-rings.  
Remove the sealing rings/O-rings from the sealing ring grooves.
2. **CAUTION!** Use only cleaning agents that are compatible with the materials used to make the device.  
Thoroughly flush and neutralize all parts that come into contact with the medium using a suitable cleaning agent.
3. When disposing the device: ⇒ Page 64.
4. When continuing to use the device: ⇒ Page 63.

## 13.3 Replacing sealing rings/O-rings

Requirements:

- All components in contact with the medium are decontaminated, ⇒ Page 63.

Proceeding:

1. Check the sealing rings/O-rings previously used for damage and replace them if necessary.
2. Install the device, ⇒ Page 23.

# 14 Shutdown

---

## 14.1 Uninstallation

Requirements:

- The system has been de-energized and secured against being switched on again.
- The medium circulation of the plant is stopped.
- The pipe is drained and rinsed.
- Suitable protective equipment has been set up.
- A clean and dry storage location has been prepared.

Procedure:

1. Loosen the knurled screw on the connecting cable by hand.
2. Pull the connecting cable out of the M12 plug connection.
3. Loosen the screw with the grounding wire and remove from the working area.
4. Threaded connector: Loosen both union nuts of the pipe adapters.  
Tri-Clamp connection: Dismantle both Tri-Clamp clamps.
5. Carefully remove the device from the plant and put in a clean and dry place.

## 14.2 Returns

Requirements:

- Clean the device housing ⇒ Page 63.
- Clean the parts that come into contact with the medium ⇒ Page 63.

Procedure:

1. The [supplementary sheet for product returns](#) must first be completed correctly and signed. Then enclose it with the shipping documents and attach it to the packaging, ideally on the outside.
2. Use the original packaging or a suitably secure container for sending the device.

## 14.3 Disposal

Requirements:

- Clean the device housing ⇒ Page 63.
- Clean the parts that come into contact with the medium ⇒ Page 63.
- Do not dispose of the device or replaced parts in the trash after use.
- Delete programs and data stored on the device.
- Remove batteries, if any, if this can be done without damaging the device.
- Dispose of the device and the packaging material in a responsible and environmentally friendly manner.
- Observe the country-specific laws and regulations for waste treatment and disposal.

In accordance with Directive 2012/19/EU on Waste from Electrical and Electronic Equipment, manufacturers are obliged to offer the option of returning waste equipment. Request the return from the manufacturer.



## 15 Accessories

### Without UL approval

Designation	Part no.
JUMO smartCONNECT (App)	00770436
IO-Link master, 1-channel (TMG Device Tool), including mini USB cable for use with Windows® PC	00694070
Line socket, 4-pole, M12 × 1, straight, length 2 m	00404585
Line socket, 4-pole, M12 × 1, angled, length 2 m	00409334

### With UL approval

Designation	Part no.
IO-Link master, 8-channel – TURCK TBEN-LL-8IOL	00759875
IO-Link master, 4-channel – TURCK TBEN-S2-4IOL	00759867
Connection line M8/voltage supply, length 2 m, IO-Link master, 4 channel	00767913
Connection line M12/voltage supply, length 2 m, IO-Link master, 8 channel	00767914
Connection line M8/Ethernet, length 2 m, IO-Link master, 4 channel	00767923
Connection line M12/Ethernet, length 2 m, IO-Link master, 8 channel	00767927
Connection line M12, M12, black, PUR, length 2 m (straight coupling/straight connector; 5 pole; A-coded)	00777804

## 16 Open-source software

---

The device software and/or device components were developed using open-source software.

Insofar as the respectively applicable license terms justify a claim on the provision of source code or other information, JUMO GmbH & Co. KG will provide the source code and the license texts on a conventional data carrier at the cost incurred for the provision of the data carrier.

This offer is valid for three years after the software is made available. This offer is valid beyond that time to the extent specified in the license terms.

For questions related to open-source software, please contact:

**Address** JUMO GmbH & Co. KG  
License Compliance  
Moritz-Juchheim-Straße 1  
36039 Fulda, Germany

**Email** [licensecompliance@jumo.net](mailto:licensecompliance@jumo.net)





**JUMO GmbH & Co. KG**

Street address:  
Moritz-Juchheim-Straße 1  
36039 Fulda, Germany

Delivery address:  
Mackenrodtstraße 14  
36039 Fulda, Germany

Postal address:  
36035 Fulda, Germany

Phone: +49 661 6003-0  
Fax: +49 661 6003-607  
Email: [mail@jumo.net](mailto:mail@jumo.net)  
Internet: [www.jumo.net](http://www.jumo.net)

**JUMO UK LTD**

JUMO House  
Temple Bank, Riverway  
Harlow, Essex, CM20 2DY, UK

Phone: +44 1279 63 55 33  
Fax: +44 1279 62 50 29  
Email: [sales@jumo.co.uk](mailto:sales@jumo.co.uk)  
Internet: [www.jumo.co.uk](http://www.jumo.co.uk)

**JUMO Process Control, Inc.**

6724 Joy Road  
East Syracuse, NY 13057, USA

Phone: +1 315 437 5866  
Fax: +1 315 437 5860  
Email: [info.us@jumo.net](mailto:info.us@jumo.net)  
Internet: [www.jumousa.com](http://www.jumousa.com)

