

# JUMO flowTRANS US W02

Ultrasonic flow meter  
for liquids



 Bluetooth®  IO-Link

Operating Manual



40605111T90Z001K000

V4.00/EN/00729309/2025-01-29

**Further information and downloads**



[qr-406051-en.jumo.info](https://qr-406051-en.jumo.info)

# Table of contents

---

<b>1</b>	<b>About this documentation</b>	<b>6</b>
1.1	Purpose	6
1.2	Target group	6
1.3	Definition of terms	6
1.4	Trademark information	6
1.5	Symbols	6
<b>2</b>	<b>Safety</b>	<b>7</b>
2.1	Intended use	7
2.2	Qualification of personnel	7
2.3	Hot surfaces	7
2.4	Hazardous materials	7
2.5	Mechanical loads	7
2.6	Transport and storage damage	8
<b>3</b>	<b>Description</b>	<b>9</b>
3.1	Structure	9
3.2	Function	9
3.3	Nameplate	10
3.4	Approval marks and certificates	10
3.5	Device ID	11
3.6	Scope of delivery	12
<b>4</b>	<b>Technical data</b>	<b>13</b>
4.1	Electrical safety	13
4.2	Electrical data	13
4.3	Inputs	14
4.3.1	Measurands	14
4.3.2	Digital inputs	15
4.4	Outputs	15
4.4.1	Analog outputs	15
4.4.2	Digital outputs	16
4.5	Interfaces	17
4.5.1	Bluetooth	17
4.5.2	IO-Link	17
4.6	Display	17
4.7	Environmental influences	18
4.8	Mechanical features	19
4.8.1	Device	19
4.8.2	Materials	19
4.8.3	Nominal pressure	19

---

# Table of contents

---

4.8.4	Pressure loss diagram	19
4.9	Measurement media	20
4.10	Dimensions	20
4.10.1	Device	20
4.10.2	Accessories	21
<b>5</b>	<b>Installation</b>	<b>22</b>
5.1	Preparing for installation	22
5.1.1	Installation site	22
5.1.2	Inlet and outlet sections	22
5.1.3	Installation position	22
5.1.4	Avoid mechanical strain	23
5.1.5	Flow direction	23
5.1.6	Alignment of the housing for electronic components	23
5.2	Installing the device	24
<b>6</b>	<b>Electrical connection</b>	<b>25</b>
6.1	Connection elements	25
6.1.1	Terminal assignment	25
6.2	Connection diagram	25
6.2.1	Digital inputs	25
6.2.2	Analog outputs	26
6.2.3	Digital outputs	26
6.3	Connecting the device	28
<b>7</b>	<b>Operation</b>	<b>30</b>
7.1	Display elements	30
7.1.1	Startup display	30
7.1.2	Process display	30
7.2	Interfaces	34
7.2.1	Bluetooth	34
7.2.2	IO-Link	34
<b>8</b>	<b>Device functions</b>	<b>35</b>
8.1	Switching points	35
8.1.1	Limit value function	35
8.1.2	Switch-on delay/switch-off delay	36
8.2	Measured value suppression	36
8.3	Low flow suppression	37
8.4	Fine adjustment	38
8.5	Totalizer	38
8.6	Batch	39

---

# Table of contents

---

<b>9</b>	<b>Configuration via Bluetooth®</b> .....	<b>40</b>
9.1	Basic settings .....	40
9.2	Functions .....	48
9.2.1	Switching points .....	48
9.2.2	Measured value suppression .....	48
9.2.3	Low flow suppression .....	48
9.2.4	Fine adjustment .....	49
9.2.5	Totalizer .....	49
9.2.6	Batch function .....	50
<b>10</b>	<b>Configuration via IO-Link</b> .....	<b>51</b>
<b>11</b>	<b>Troubleshooting</b> .....	<b>62</b>
11.1	Process value error .....	62
11.2	Error messages in line with NAMUR .....	63
11.3	Error messages outside NAMUR .....	65
<b>12</b>	<b>Maintenance and cleaning</b> .....	<b>66</b>
12.1	Cleaning device housing .....	66
12.2	Decontamination .....	66
12.3	Replacing O-rings .....	66
<b>13</b>	<b>Shutdown</b> .....	<b>67</b>
13.1	Uninstallation .....	67
13.2	Returns .....	67
13.3	Disposal .....	67
<b>14</b>	<b>Accessories</b> .....	<b>68</b>
<b>15</b>	<b>Certificates</b> .....	<b>69</b>
15.1	China RoHS .....	69

---

# 1 About this documentation

---

## 1.1 Purpose

This documentation is part of the device and includes all information to ensure that it is used safely and as intended across all phases of the product lifecycle.

If you do not follow the documentation and safety information, this may result in risk to life and damage to property due to improper use.

- Read and follow the documentation and the safety information and warnings.
- Store the document in its entirety, in an easily accessible location, and so that it can be read in full at all times.
- Contact the manufacturer if you have any questions about the device and documentation.

## 1.2 Target group

This documentation is intended to be used by personnel trained in electrical, mechanical, and plant engineering across all phases of the product lifecycle.

## 1.3 Definition of terms

Use in the documentation	Definition
Device, inline device, product	Ultrasonic flowmeter
Medium, measurement medium, fluid	Liquid
Transducer	Ultrasonic converter, transducer, sensor
Volume flow, flow	Totalized flow rate per time span
Product lifecycle	Overall consideration of Product identification, acceptance of the goods, storage, mounting, connection, operation, troubleshooting, maintenance to disposal

## 1.4 Trademark information

All trademarks and trade and company names used are the property of their rightful owners or authors.

## 1.5 Symbols

### NOTE!



This symbol is used in tables and indicates that further information is provided after the table.

---

### REFERENCE!



This symbol refers to **further information** in other sections, chapters, or other manuals.

---

### 2.1 Intended use

The ultrasonic flowmeter measures the flow, temperature and (optionally) the pressure of conductive and non-conductive liquid media.

It is mounted in pipes made from plastic or metal.

The documentation is part of the device. The device is only intended for use according to this documentation.

### 2.2 Qualification of personnel

The personnel deployed must meet the following requirements in all phases of the product lifecycle:

- Trained electrical, mechanical, and plant engineering personnel.
- Members of personnel are familiar with this documentation and the safety information and warnings it contains.

### 2.3 Hot surfaces

Hot device surfaces pose a risk of injury. Hot device surfaces can be caused by the use of hot media in applications.

- If required, install contact protection.
- Take into account the alignment of the housing for electronic components, ⇒page 23.

When working on the device:

- Allow the device and plant to cool down.
- Wear suitable protective equipment.

### 2.4 Hazardous materials

Using hazardous materials as a medium may result in abrasive and corrosive damage to components of the product that come into contact with the medium. The medium may leak and present a fire hazard and a risk to health.

Carry out a risk assessment taking into consideration the safety data sheet for the relevant hazardous substance for mounting, operation, maintenance, cleaning, and disposal:

- Comparison and systematic checking of the durability of the components of the product that come into contact with the medium and the admissible environmental influences.
- Assessment of the risk to people and the environment.
- Assessment of the fire hazard due to the product materials, the admissible environmental influences, and the voltage supply.

### 2.5 Mechanical loads

Mechanical load on the device and process connections can lead to leaks.

- Do not place the device and the process connections under mechanical strain.
- Systematically check that the process connections are leak-tight.

## 2 Safety

---

### 2.6 Transport and storage damage

The device can be damaged if it is insufficiently protected during transport and/or improperly stored.

- Transport the device protected from moisture and dirt in shockproof packaging.
- Protect all electrical and mechanical connections from damage.
- Observe the admissible storage temperature of the device.
- Store the device in a dry and dust-free environment.

## 3.1 Structure

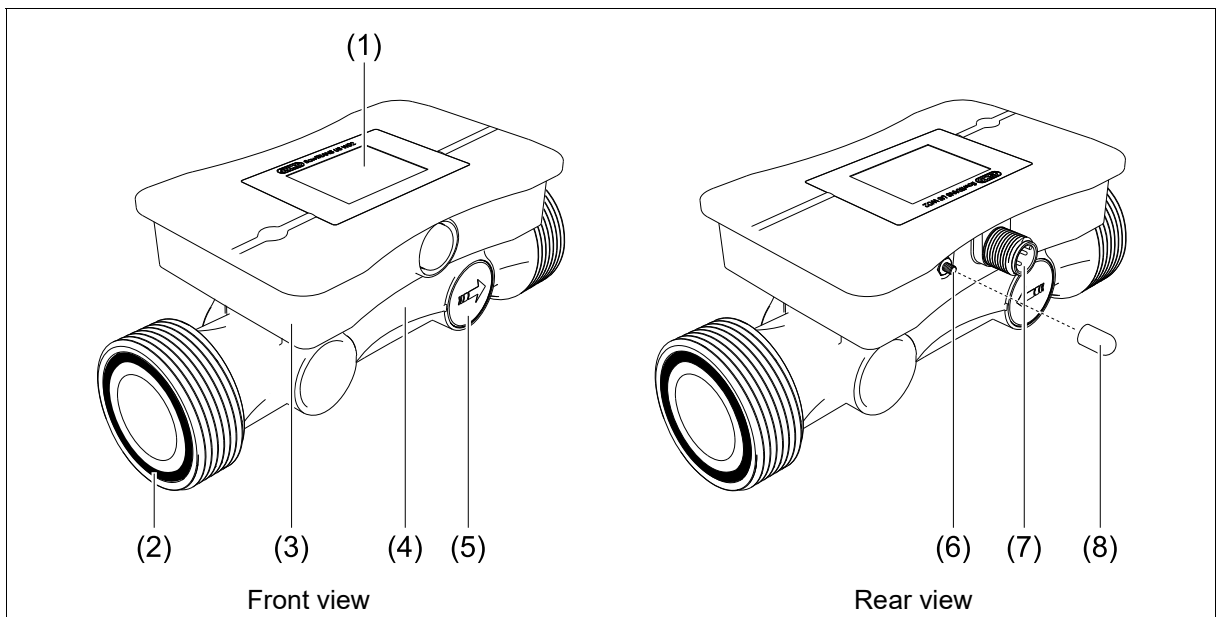

- |   |  |   |                                       |
|---|--|---|---------------------------------------|
| 1 | Display                                  | 5 | Transducer (ultrasonic converter)     |
| 2 | O-ring (seal for the process connection) | 6 | Grounding terminal                    |
| 3 | Housing for electronic components        | 7 | M12 plug connector                    |
| 4 | Measuring pipe                           | 8 | Protective cap for grounding terminal |

## 3.2 Function

The transducers are on opposite sides of the measuring section and act as transmitters and receivers, i.e. they convert the electrical energy into sound waves and the sound waves into electrical energy.

The electronic components supply power to the device, convert the raw signals into standard signals for communicating with other systems (PLC, recorder, indicating device, etc.), and provide interfaces for displaying measured values.

### Function principle

The ultrasonic flowmeter works according to the runtime method.

This method measures the runtimes  $t_1$  and  $t_2$  required by the sound to travel from transducer A to transducer B and vice versa.

→ = Flow direction

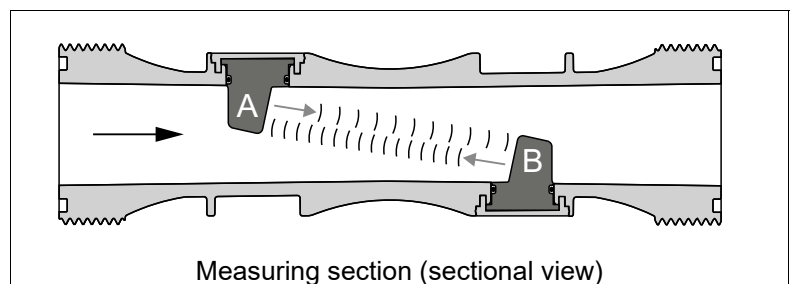

The runtime differential  $\Delta t$  is directly proportional to the flow velocity of the medium.

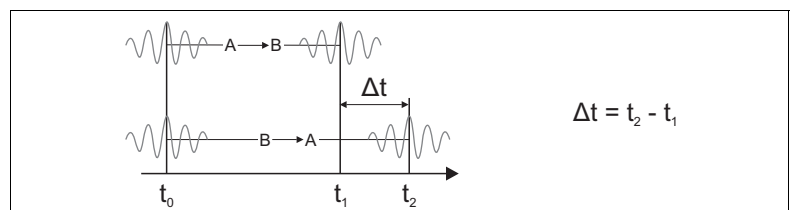

## 3 Description

### 3.3 Nameplate

Example:

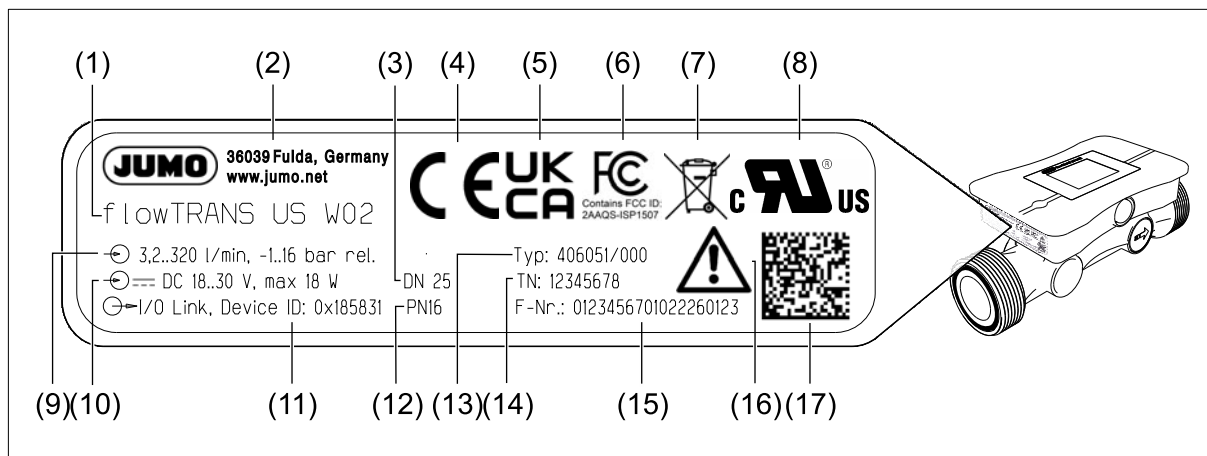

1	Device designation	10	Voltage supply (DC)
2	Manufacturer and address	11	IO-Link device ID
3	Nominal width	12	Nominal pressure level
4	CE identification marking	13	Order code
5	UKCA identification marking	14	Part no.
6	FCC identification marking	15	Fabrication number
7	Disposal	16	Observe device documentation!
8	UL identification marking	17	Data Matrix Code
9	Measuring range		

### 3.4 Approval marks and certificates



Certificates for approved device versions are available for download on the manufacturer's website.

#### Federal Communications Commission (FCC)

This device complies with part 15 of the FCC rules. Operation is subject to the following two conditions.

- (1) This device may not cause harmful interference.
- (2) This device must accept any interference received, including interference that may cause undesired operation.

Caution: Any Changes or modifications not expressly approved by the party responsible for compliance could void the user's authority to operate the equipment.

#### Radio Equipment Directive (RED)

JUMO GmbH & Co. KG hereby declares that the JUMO flowTRANs US W02 device complies with the Directive 2014/53/EU. The full text of the EU Declaration of Conformity is available at the following web address: [qr-406051-en.jumo.info](http://qr-406051-en.jumo.info).

## Radio equipment regulations 2017

JUMO GmbH & Co. KG hereby states that the flowTRANS W02 device complies with the radio equipment regulations UK S.I. 2017 No. 1206. The full text of the UK Declaration of Conformity is available at the following web address: [qr-406051-en.jumo.info](http://qr-406051-en.jumo.info).

## 3.5 Device ID

The device ID is shown on the nameplate (⇒ Page 10) and identifies the device version. A device description file (IODD) is assigned to each device ID which is used for communication via the IO-Link interface, ⇒ Page 34.

### Nominal width: DN 15 with low-flow calibration

Device ID	Device version	IODD
0x18403_	DN15LF flowmeter	JUMO-184031-*.xml
0x1841B_	DN15LF flowmeter/pressure sensor -1 to +10 bar rel.	JUMO-1841B1-*.xml
0x18423_	DN15LF flowmeter/pressure sensor -1 to +16 bar rel.	JUMO-184231-*.xml

### Nominal width: DN 15

Device ID	Device version	IODD
0x18483_	DN15 flowmeter	JUMO-184831-*.xml
0x1849B_	DN15 flowmeter/pressure sensor -1 to +10 bar rel.	JUMO-1849B1-*.xml
0x184A3_	DN15 flowmeter/pressure sensor -1 to +16 bar rel.	JUMO-184A31-*.xml

### Nominal width: DN 20

Device ID	Device version	IODD
0x18503_	DN20 flowmeter	JUMO-185031-*.xml
0x1851B_	DN20 flowmeter/pressure sensor -1 to +10 bar rel.	JUMO-1851B1-*.xml
0x18523_	DN20 flowmeter/pressure sensor -1 to +16 bar rel.	JUMO-185231-*.xml

### Nominal width: DN 25

Device ID	Device version	IODD
0x18583_	DN25 flowmeter	JUMO-185831-*.xml
0x1859B_	DN25 flowmeter/pressure sensor -1 to +10 bar rel.	JUMO-1859B1-*.xml
0x185A3_	DN25 flowmeter/pressure sensor -1 to +16 bar rel.	JUMO-185A31-*.xml

### Nominal width: DN 32

Device ID	Device version	IODD
0x1861B_	DN32 flowmeter/pressure sensor -1 to +10 bar rel.	JUMO-1861B1-*.xml

## 3 Description

---

### 3.6 Scope of delivery

Device in the ordered version
Brief instructions
Calibration certificate
2 O-rings (seal for the process connection) in the ordered version

### 4.1 Electrical safety

Requirements	DIN EN 61010-1 The device must be equipped with an electrical circuit that meets the requirements for "Limited-energy circuits".
--------------	---

### 4.2 Electrical data

Voltage supply	DC 18 to 30 V SELV, PELV, Class 2
Current consumption	
IO-Link operation	≤ 100 mA
Operation with switching output	≤ 600 mA
Power consumption	
IO-Link operation	≤ 3 W
Operation with switching output	≤ 18 W
Protection rating	DIN EN 61140, Class III (protective low voltage)
Electrical connection	
Connection elements	
Device	M12 plug connector, grounding terminal M2.5
Connecting cable	M12 plug connector
Grounding cable	Ring cable lug M2.5
M12 plug connector	IEC 61076-2-101
Version	4-pole, shielded
Connecting cable	
Conductor cross section	
IO-Link operation	≥ AWG 28
Operation with switching output	≥ AWG 21
Version	4-core, copper, shielded
Line length	≤ 20 m
Temperature resistance	≥ 80 °C
For UL application	
Approved cables <sup>a</sup>	CYJV2/8, CYJV/7, PVVA2/8, PVVA/7
Grounding cable	
Conductor cross section	1.5 mm <sup>2</sup>
Version	1-core, copper
Temperature resistance	≥ 80 °C

<sup>a</sup> The cables must be suitable for the voltage, current and temperature used.

## 4 Technical data

### 4.3 Inputs

#### 4.3.1 Measurands

##### Flow

Flow <sub>max</sub> DN 15 (Low-flow calibration) DN 15 DN 20 DN 25 DN 32	60 l/min 80 l/min 210 l/min 320 l/min 520 l/min
Accuracy <sup>a</sup> Pulse output Current output Voltage output Reproducibility Temperature drift Response time t <sub>90</sub>	≤ ±1.0% of the measured value ±0.03% of flow <sub>max</sub> Like pulse output, additionally ≤ ±0.1% of 16 mA Like pulse output, additionally ≤ ±0.1% of 10 V ≤ ±0.5% of measured value ±0.03% of flow <sub>max</sub> ≤ ±0.05% of measured value per 10 K temperature change (at -20 to +80 °C) ≤ 2 s
Reference conditions Measurement medium Medium temperature Ambient temperature Medium pressure Measuring tube	Water 23 °C (73 °F) ±5 K 23 °C (73 °F) ±5 K 1 to 4 bar Horizontal installation, compliance with the required inlet and outlet sections
X = Flow (%) based on flow <sub>max</sub> Y = Deviation (%) from measured value	<p>The graph plots Deviation (%) on the Y-axis (0 to 5) against Flow (%) on the X-axis (0 to 100). The curve shows a sharp initial drop from ~4% deviation at 0% flow to ~1.5% at 5% flow, then continues to decrease and levels off at approximately 1% deviation for flows above 10%.</p>

<sup>a</sup> Under reference conditions.

##### Temperature

Measuring range	-40 to +125 °C
Accuracy	±2 K

### Pressure (optional)

Measuring range DN 15, DN 20, DN 25 DN 32	-1 to +16 bar relative pressure -1 to +10 bar relative pressure
Accuracy At 20 °C <sup>a</sup> At -20 to +100 °C <sup>c</sup>	±0.4% MSP <sup>b</sup> ±1% MSP

<sup>a</sup> Includes: linearity, hysteresis, repeatability, deviation of measuring range initial value, and measuring range end value.

<sup>b</sup> MSP = measuring span.

<sup>c</sup> Includes: linearity, hysteresis, repeatability, deviation of measuring range initial value, and measuring range end value, thermal effect on measuring range start and measuring span.

### 4.3.2 Digital inputs

Function	Reset totalizer, start/stop batch, measured value suppression
Type	Logic input (external voltage supply)
Switching voltage $V_{DI}$	DC $-30\text{ V} \leq V_{DI} \leq +30\text{ V}$
Protection	Against polarity and voltage peaks
Internal resistance	> 100 k $\Omega$
Switching thresholds	PLC level: logic level "0" < 7 V, logic level "1" > 15 V

## 4.4 Outputs

### 4.4.1 Analog outputs

Current output Function Signal range Signal limits Error message Temperature influence Burden Burden influence	Output of the flow process values, temperature or pressure (optional), output of a signal for error message 4 to 20 mA 3.8 to 20.5 mA 3.4 or 22 mA 75 ppm/K $\leq 500\ \Omega$ $\leq \pm 0.02\%$ per 100 $\Omega$
Voltage output Function Signal range Signal limits Error message Temperature influence Load Load influence	Output of the flow process values, temperature or pressure (optional), output of a signal for error message DC 0 to 10 V DC 0 to 10.3 V DC 0 or 11 V 75 ppm/K $\geq 2000\ \Omega$ $\leq \pm 15\text{ mV}$

## 4 Technical data

---

### 4.4.2 Digital outputs

Type	Transistor output as switching output or pulse output (I/O pin 1 only)
Protection	Against polarity reversal, short circuiting and overload
Output signal	Push-pull, PNP, NPN
Ampacity	≤ 200 mA
Voltage drop	≤ 3 V
Switching output	
Function	Limit value monitoring function
Input signal	Flow, temperature or pressure (optional)
Output signal	Limit value switch, batch active, batch error, device error
Switch-on and switch-off delay	0 to 100 s
Limit value function	Hysteresis (NO contact/NC contact), window (NO contact/NC contact), switch-on and switch-off delay
Switching point	Configurable
Pulse output	
Function	Output of the flow process value
Pulse frequency	0 to 10 kHz
Duty cycle	50 %
Output value at nominal width <sup>a</sup>	Pulses per liter (l)
DN 15 (low-flow calibration)	10000
DN 15	4800
DN 20	2850
DN 25	1875
DN 32	1150

<sup>a</sup> Default setting (configurable).

### 4.5 Interfaces

#### 4.5.1 Bluetooth

Function	Transfer of configuration data and device information, display of process values
Communication	Via end device with JUMO smartCONNECT app
Authentication	Via Bluetooth® radio module and NFC tag
Connection status (configurable)	
Permanently	Active
Temporarily	Restricted (via NFC)
Range	10 m under reference conditions
Radio frequency	
Bluetooth® radio module	2.4 GHz
NFC tag	13.56 MHz
Max. transmission power	
Bluetooth® radio module	0 dBm
NFC tag	–
JUMO smartCONNECT app	
System requirements	
iOS device	iPhone 7 or later (recommended) with iOS 13
Android device	Android 8.0 or later

#### 4.5.2 IO-Link

Function	Transfer of process data, configuration data and device information, displaying of process values
Communication	Via end device with IO-Link master and device description file (IODD)
Communication interface	IO-Link device V 1.1
Data transfer rate (baud rate)	COM 3 (230.4 kBaud)
Cycle time	≥ 5 ms
Profile	Common Profile, Smart Sensor Profile

### 4.6 Display

Type	TFT display
Size	
Display range	35.04 × 28.03 mm
Screen size (diagonal)	1.77"
Resolution	128 × 160 RGB
Brightness	15 levels active + 1 level inactive (configurable)
Rotation	0°, 90°, 180°, 270° (configurable)

## 4 Technical data

---

### 4.7 Environmental influences

The product is UL-approved. The approval stipulates that the product may be used indoors only.

Admissible ambient temperature At medium temperature $\leq 50$ °C At medium temperature $\leq 80$ °C <sup>a</sup> At medium temperature $> 80$ °C <sup>a</sup>	DIN 60068-2-1, DIN 60068-2-2 -20 to +50 °C -20 to +60 °C -20 to +45 °C
Admissible storage temperature	-20 to +60 °C
Climatic conditions Climate class Air temperature Relative humidity	DIN EN 60721-3-1, DIN EN 60721-3-3, DIN EN 60068-2-78 3K6 -20 to +55 °C $\leq 100$ % – Condensation on device outer shell
Protection type	DIN EN 60529, EN 50102 IP65, IP67
Electromagnetic compatibility (EMC) Interference emission Interference immunity	DIN EN 61326-2-3:2022 Class B <sup>b</sup> Industrial requirements
Oscillation Amplitude Acceleration	DIN EN 60068-2-6 0,35 mm at 10 to 2000 Hz 5 g at 10 to 2000 Hz
Shock Peak acceleration Shock duration	DIN EN 60068-2-27 20 g 11 ms
Pressure Equipment Directive Group 1 fluids - DN $\leq 25$ Group 2 fluids - DN $\leq 32$ Group 1 fluids	2014/68/EU Sound engineering practice acc. to Art. 4, para. 3 i. c. w. Art. 4 para. 1c.i Sound engineering practice acc. to Art. 4, para. 3 i. c. w. Art. 4 para. 1c.i Sound engineering practice acc. to Art. 4, para. 3 i. c. w. Art. 4 para. 1c.ii

<sup>a</sup> Without UL approval.

<sup>b</sup> The product is suitable for industrial use as well as for households and small businesses.

## 4.8 Mechanical features

### 4.8.1 Device

Weight <sup>a</sup> Without screw connection	≥ 215 to ≤ 385 g
---	------------------

<sup>a</sup> Depends on version and DN.

### 4.8.2 Materials

Housing	PA66-GF25
Display cover	PMMA
Components in contact with the medium Measuring tube Transducer Seals Process connection, transducer	PPSU PEEK EPDM or FKM (optionally)
Approvals Components in contact with the medium	Drinking water certified materials (when using EPDM seals)

### 4.8.3 Nominal pressure

Nominal pressure level DN 15, DN 20, DN 25 DN 32	PN 16 PN 10
--	----------------

### 4.8.4 Pressure loss diagram

Created under reference conditions ⇨ Page 14.

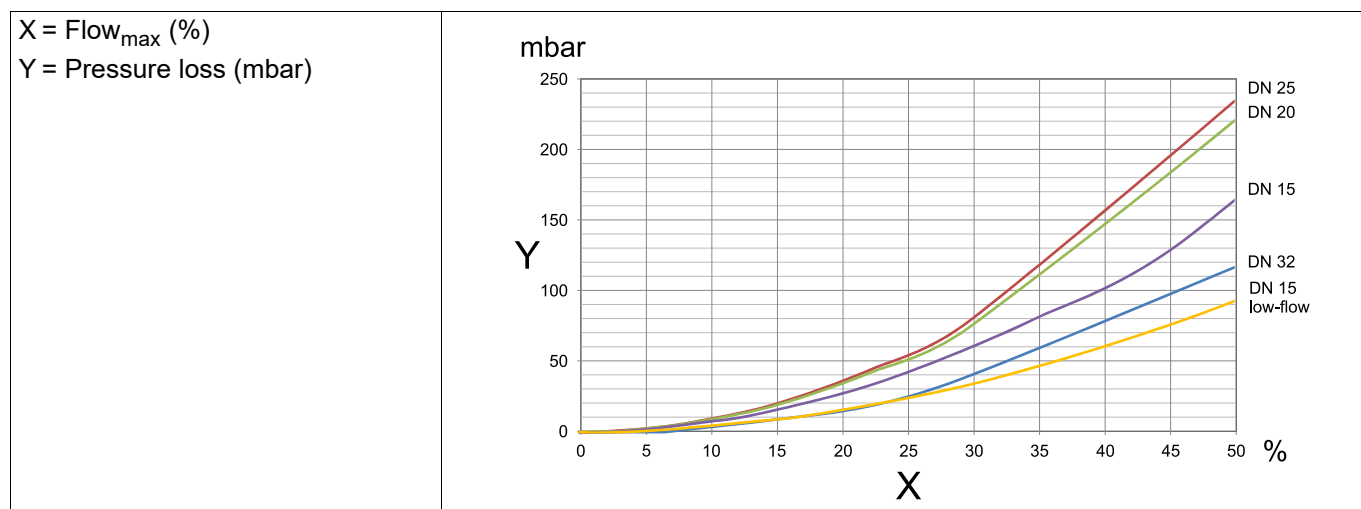

## 4 Technical data

### 4.9 Measurement media

Medium type	Conductive or non-conductive liquids
Viscosity	$\leq 100$ mPas
Foreign matter content	
Solids	$\leq 5$ % vol $\leq 1$ % vol
Medium temperature	
Temperature range	-20 to +95 °C
Within the accuracy	-20 to +50 °C
Within the accuracy <sup>a</sup>	-20 to +80 °C
Outside of the accuracy <sup>a, b</sup>	> 80 to 95 °C

<sup>a</sup> Without UL approval.

<sup>b</sup> Return to the accuracy after cooling down.

### 4.10 Dimensions

#### 4.10.1 Device

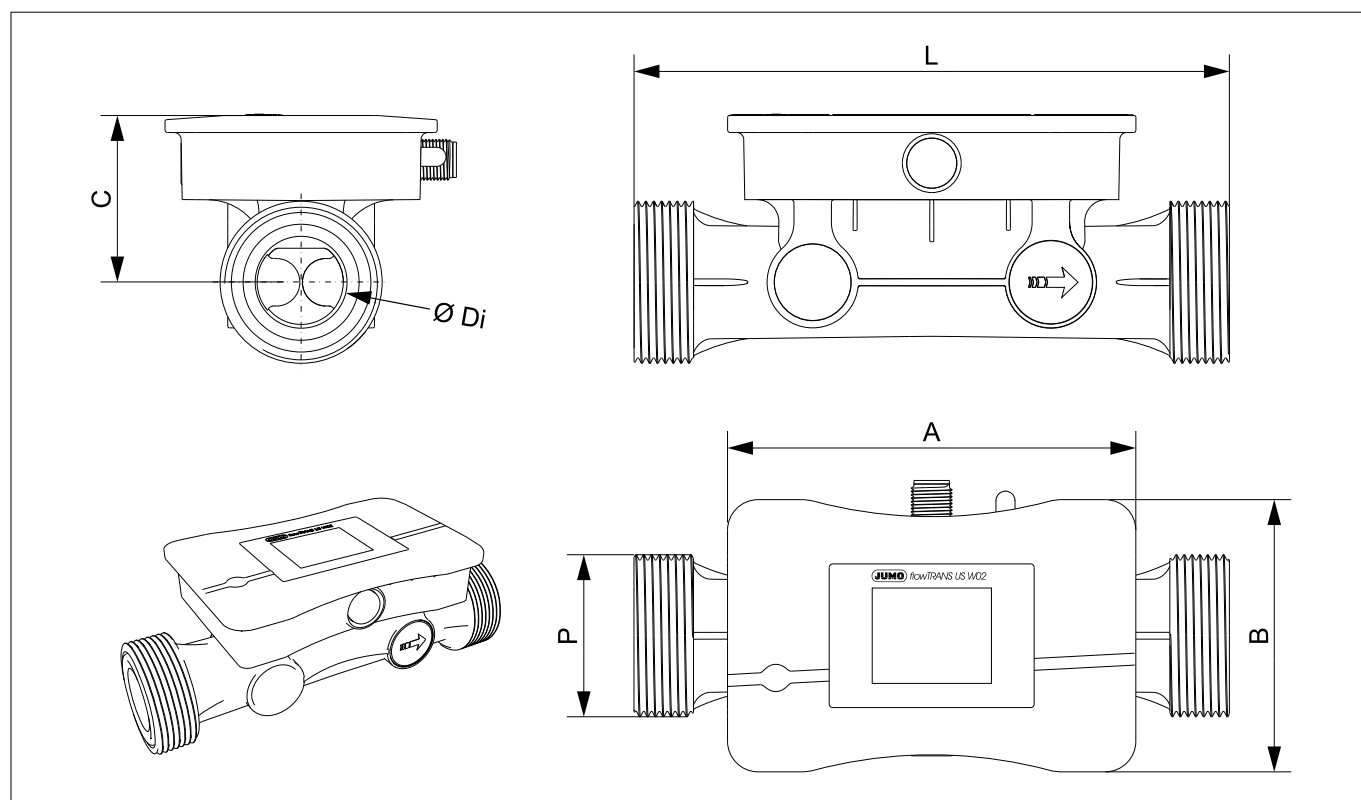

Nominal width	Ø Di [mm]	P	A [mm]	B [mm]	C [mm]	L [mm]
DN 15	16.5	G 1	120	80	43.5	155
DN 20	21.5	G 1 1/4			46	165
DN 25	27	G 1 1/2			49	175
DN 32	34	G 2			52.5	185

## 4.10.2 Accessories

### Mounting sets

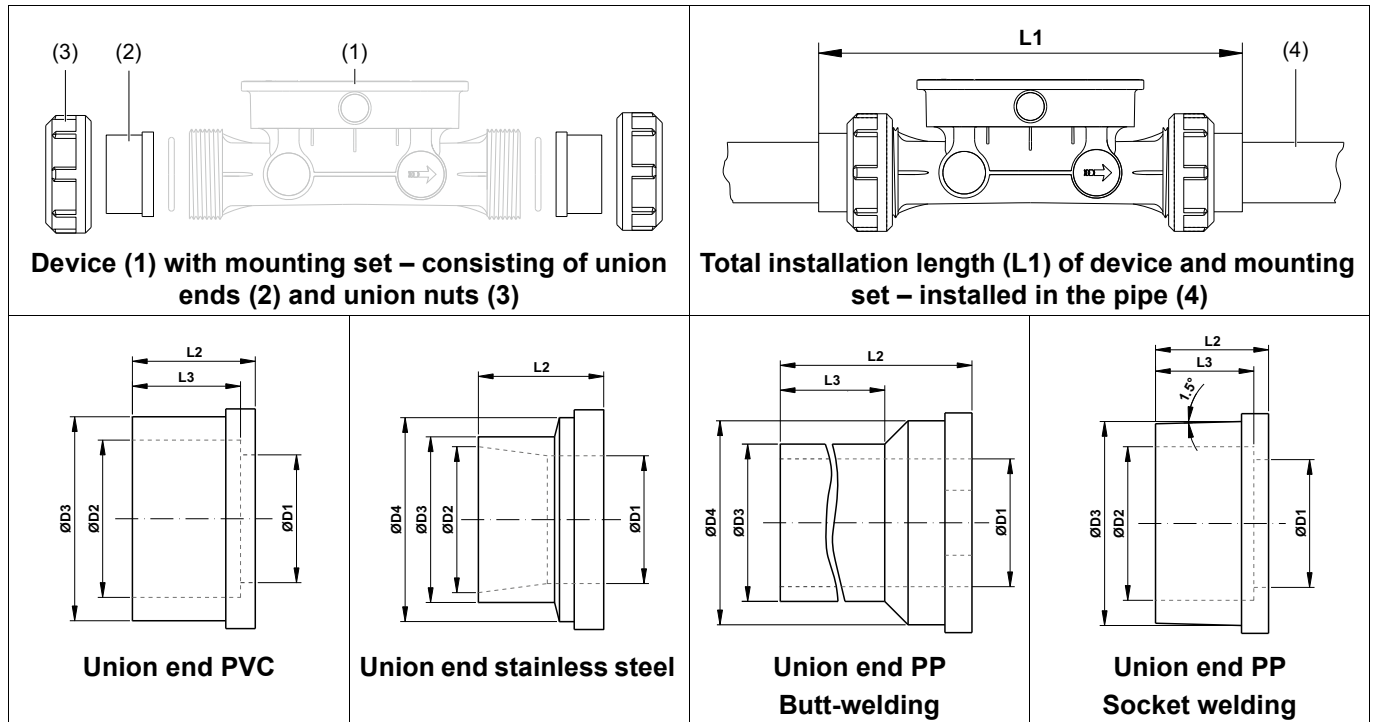

Nominal width	ØD1 [mm]	ØD2 [mm]	ØD3 [mm]	ØD4 [mm]	L1 [mm]	L2 [mm]	L3 [mm]
<b>Union end PVC</b>							
DN 15 to DN 10	10.5	16	23.5	27.5	203	24	16
DN 15	15	20	27.5	-	198	19	16
DN 20	22	25	36	-	209	22	19
DN 25	26	32	41.5	-	225	25	22
DN 32	33	40	53	-	243	29	26
<b>Union end stainless steel</b>							
DN 15 to DN 10	10.5	16	23.5	27.5	203	24	16
DN 15	15	17.3	21.3	27.5	203	21.5	-
DN 20	22	22.9	26.9	36	210	22.5	-
DN 25	26	29.7	33.7	41.5	226	25.5	-
DN 32	33	38.4	42.4	53	236	25.5	-
<b>Union end PP butt-welding</b>							
DN 15	15/16.2	-	20	27.5	266	53	37.75
DN 20	19.8	-	25	36	277.8	56.4	38.6
DN 25	26	-	32	41.5	293	59	41.25
DN 32	32.6	-	40	53	310.6	62.8	41.8
<b>Union end PP socket-welding</b>							
DN 15	17	19.35	27.5	-	198	19	16
DN 20	21	24.3	36	-	207	21	18
DN 25	26	31.25	41.5	-	221	23	20
DN 32	33	39.2	53	-	235	25	22

# 5 Installation

## 5.1 Preparing for installation

### 5.1.1 Installation site

Requirements:

- The device is protected from electromechanical interference.
- The device is protected from UV radiation.
- The device is protected from the weather in outdoor applications.

### 5.1.2 Inlet and outlet sections

To ensure measurement accuracy, longer inlet and outlet distances may be required depending on the application.

DN = Nominal pipe width

→ = Flow direction

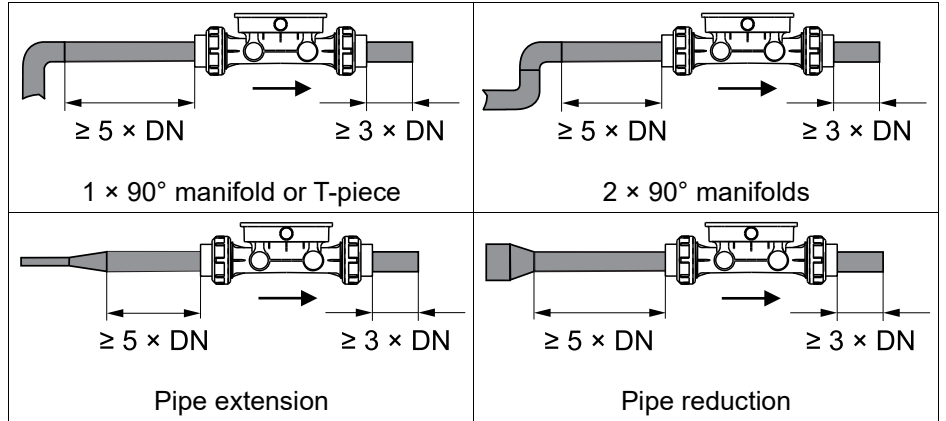

### 5.1.3 Installation position

→ = Flow direction

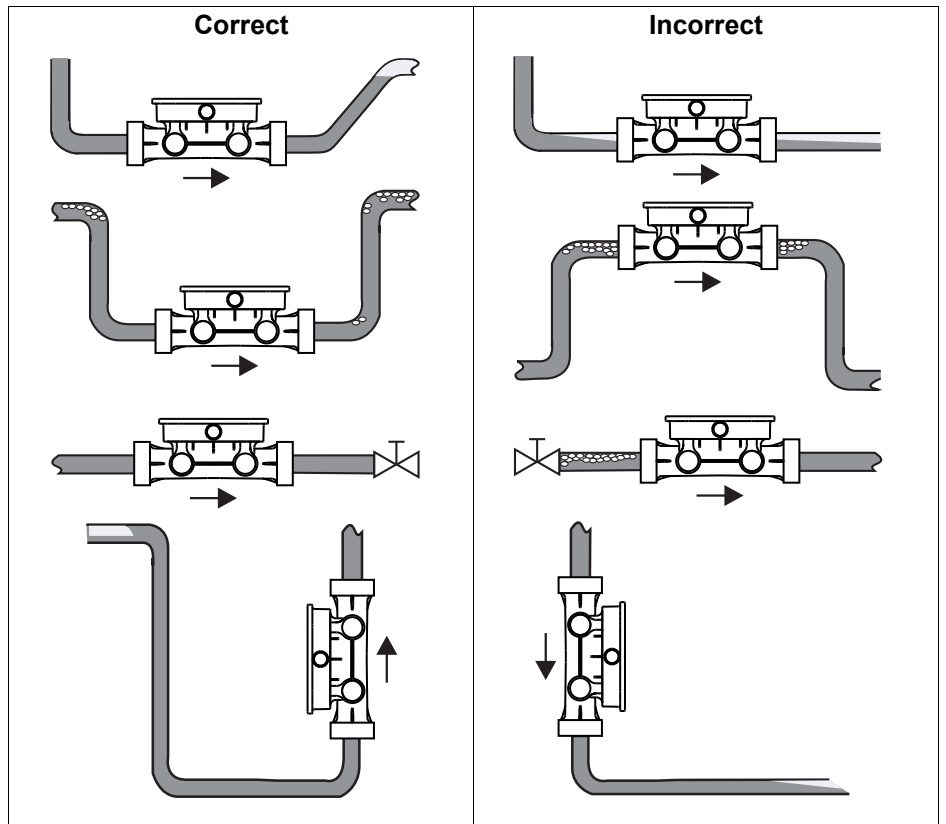

## 5.1.4 Avoid mechanical strain

Requirements:

- The center axes of both pipe ends are aligned (A-B) before mounting in the pipeline (1).
- The pipe ends are aligned parallel and at an angle to each other (C).
- The insertion length (L) of the device is observed.

Mounting sets, ⇨Page 68.

Dimensions, ⇨Page 21.

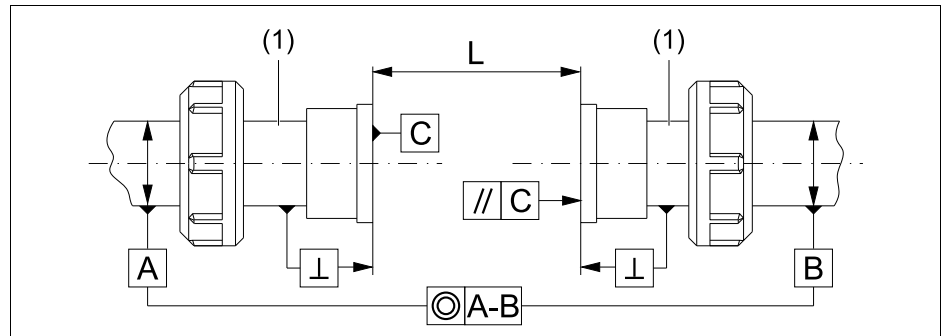

Nominal width	Insertion length L [mm]
DN 15	155
DN 20	165
DN 25	175
DN 32	185

## 5.1.5 Flow direction

The positive flow direction (→) is shown on the transducer covers on both sides of the device and must be observed during installation, in accordance with the application in question.

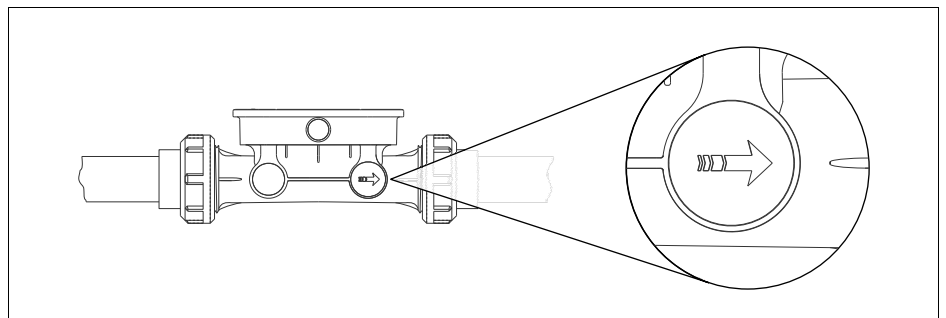

## 5.1.6 Alignment of the housing for electronic components

**CAUTION!** Protect the electronics housing from heating up by hot media. Install the electronics housing oriented 90° to the side at medium temperatures > 60 °C (140 °F).

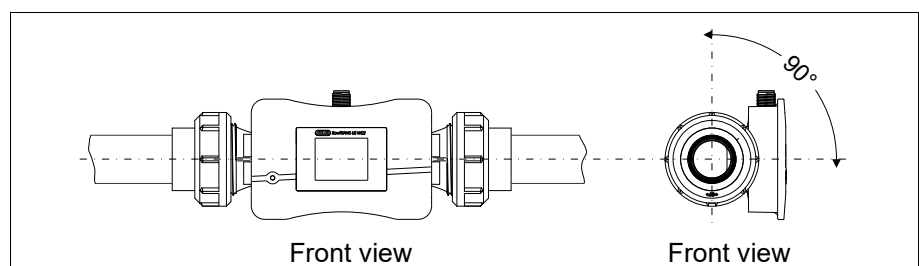

# 5 Installation

## 5.2 Installing the device

Describes the installation in the pipe with accessory mounting kits, ⇨Page 21.

Material	2 O-rings (process connection seals)
----------	--------------------------------------

Requirements:

- The system has been de-energized and secured against being switched on again.
- The medium circulation of the plant is stopped.
- The pipe is drained and rinsed.
- Suitable protective equipment has been set up.
- The pipe is prepared for installation with the mounting kits.

Procedure:

1. Insert the O-rings (1) into the sealing ring grooves in the two process connections.

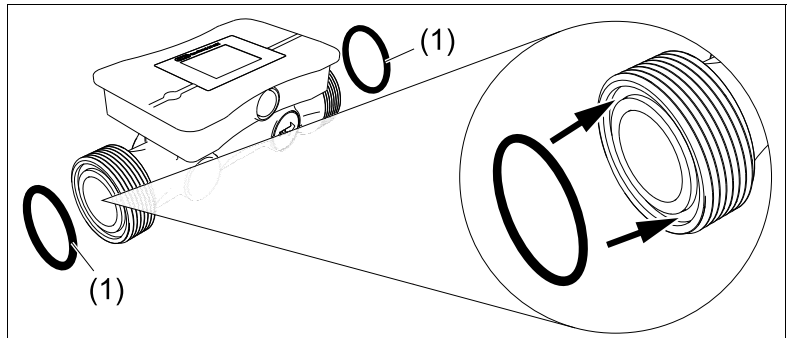

2. Install the device between the two union ends (3) of the mounting set.

Ensure that the O-rings (1) between the process connections (2) and union ends are correctly positioned.

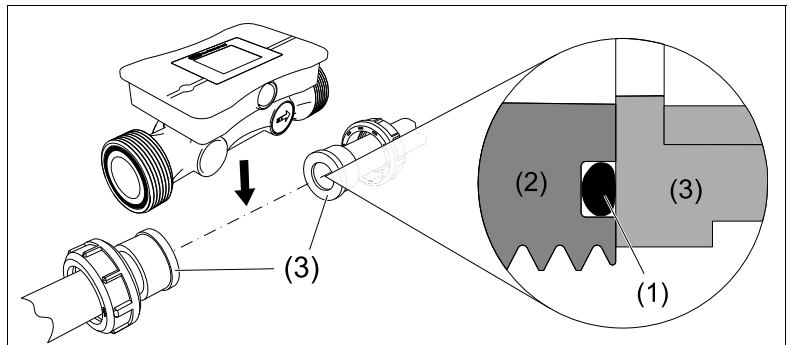

3. Manually screw union nuts (4) on both ends of the pipe to the process connections on the device.

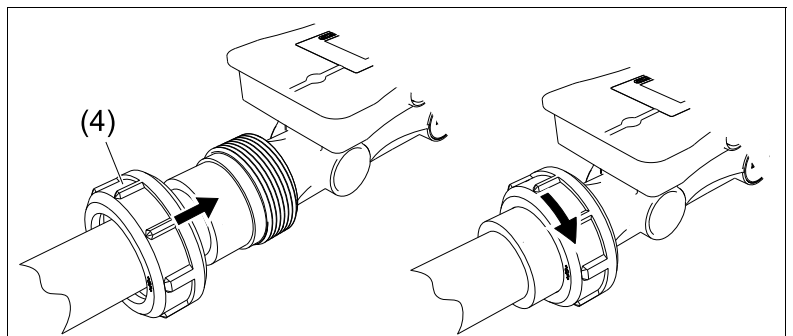

4. Switch on the plant, fill the pipe and check the tightness of the process connections under operating conditions.

The device is now installed in the pipe.

## 6.1 Connection elements

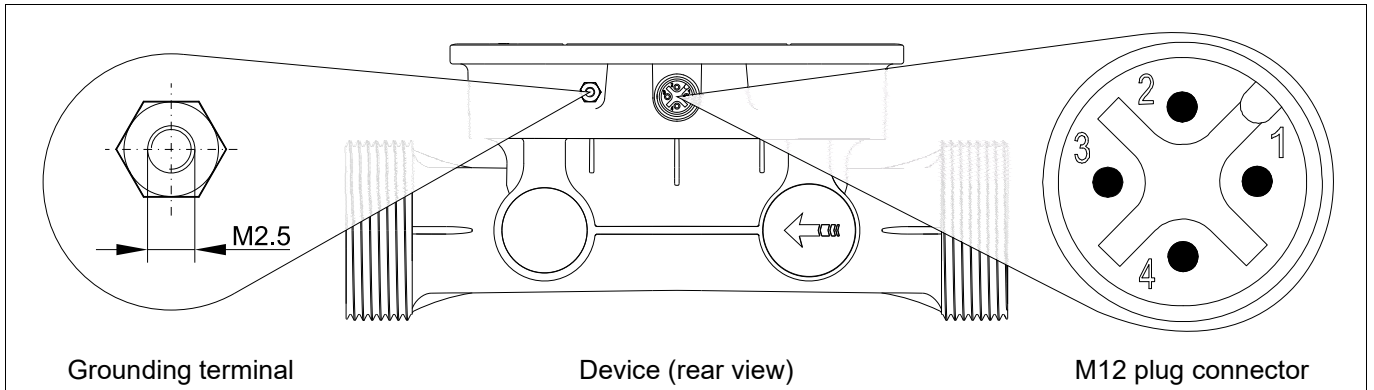

### 6.1.1 Terminal assignment

#### M12 plug connection

Designation	Description	Assignment
IO-Link	DC 24 V	1 BN (Brown)
	I/O-Pin 2 <sup>a</sup>	2 WH (White)
	GND	3 BU (Blue)
	IO-Link, I/O-Pin 1 <sup>b</sup>	4 BK (Black)

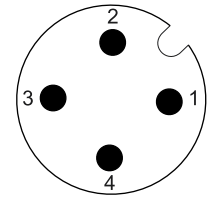
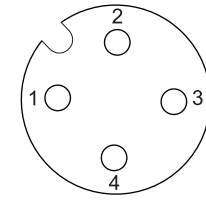
<sup>a</sup> Configurable as: Digital input, digital output, analog output.

<sup>b</sup> Configurable as: IO-Link, digital output, analog output.

## 6.2 Connection diagram

### Requirements:

- An unused current output is connected to GND.
- An unused voltage output is open.

### 6.2.1 Digital inputs

PLC level: logic level "0" < 7 V, logic level "1" > 15 V

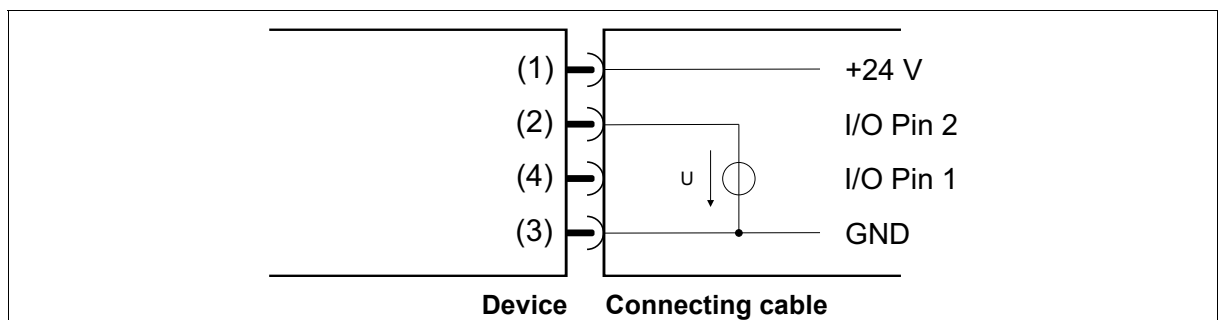

# 6 Electrical connection

## 6.2.2 Analog outputs

I/O Pin 1 and/or I/O Pin 2 can be configured as analog output.

The connection examples for I/O Pin 2 also apply to I/O Pin 1.

### Current output – 4 to 20 mA

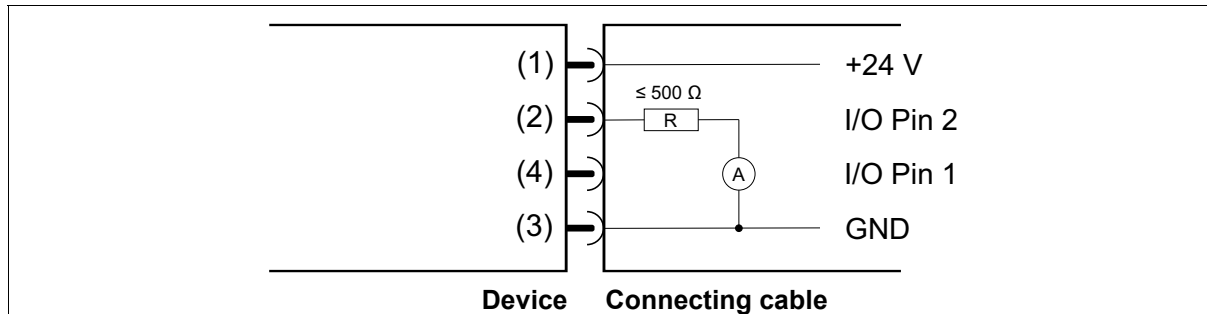

### Voltage output – 0 to 10 V

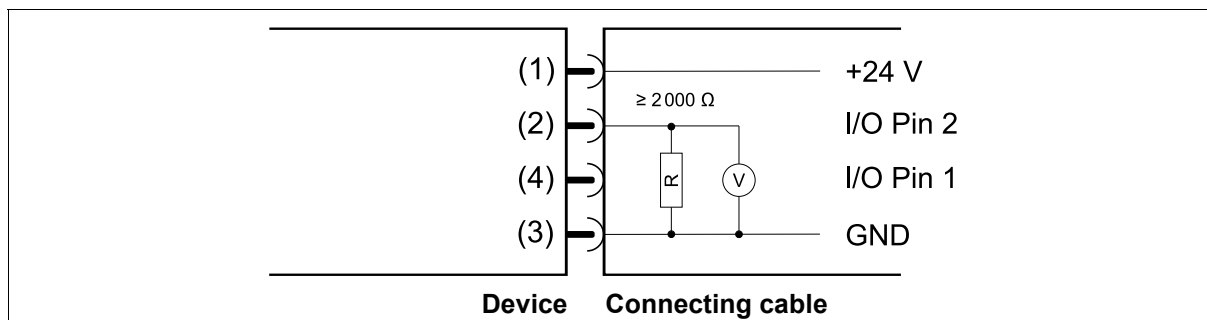

## 6.2.3 Digital outputs

I/O Pin 1 and/or I/O Pin 2 can be configured as digital output.

I/O Pin 1 can be configured as switching or pulse output; I/O Pin 2 can be configured as switching output.

The connection examples for I/O Pin 1 also apply to I/O Pin 2.

### Digital output – push-pull (example 1)

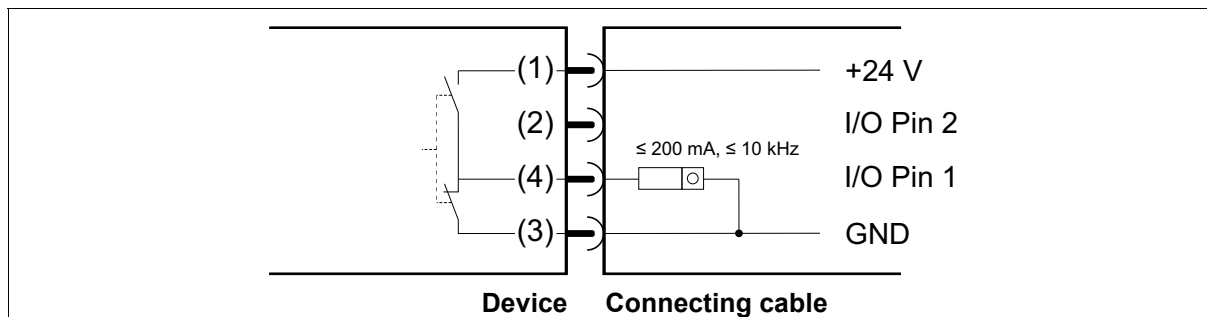

## 6 Electrical connection

### Digital output – push-pull (example 2)

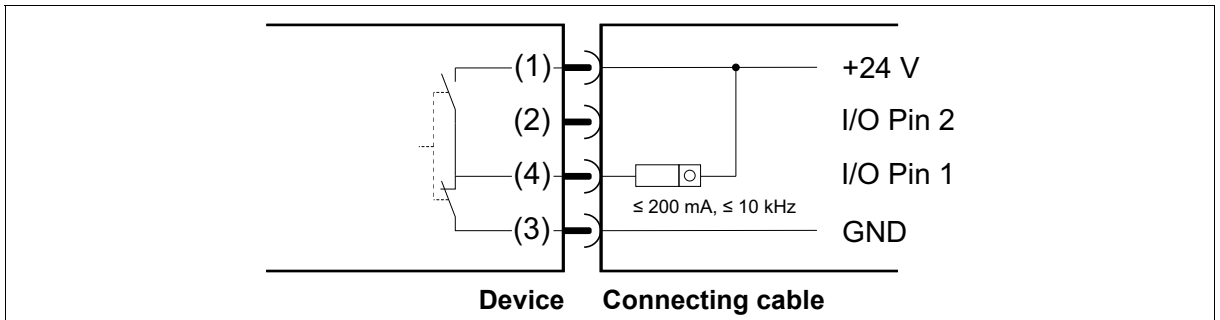

### Digital output – NPN (n-switching)

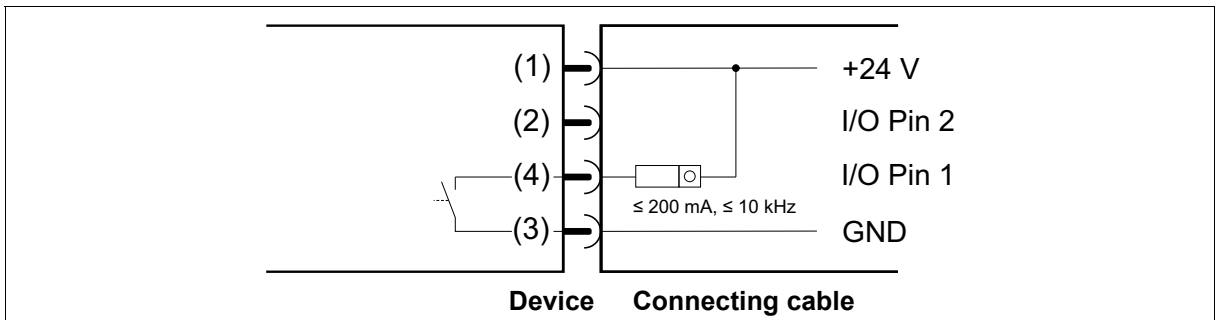

### Digital output – PNP (p-switching)

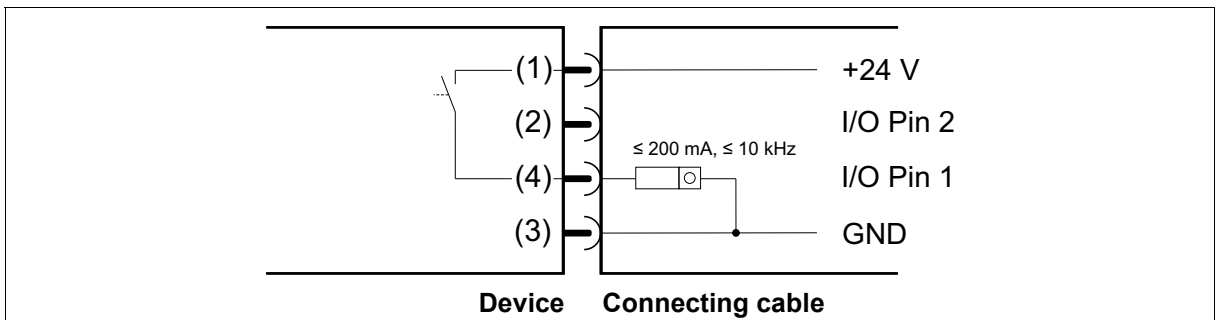

# 6 Electrical connection

## 6.3 Connecting the device

Aids	Torque wrench with socket insert, SW5
Materials	Connecting cable for plug connector M12
	Grounding cable with ring cable lug M2,5
	Hexagon nut DIN EN ISO 4032 M2,5

### Requirements:

- The system has been de-energized and secured against being switched on again.
- The connections for grounding, voltage supply and signal processing are professionally prepared.
- The connection cable and the grounding cable are temperature resistant according to the process.
- The connection cable is installed at a minimum distance of 30 cm from high-voltage or high-frequency cables.

### Procedure:

1. Remove the protective cap (1) from the grounding terminal (2).

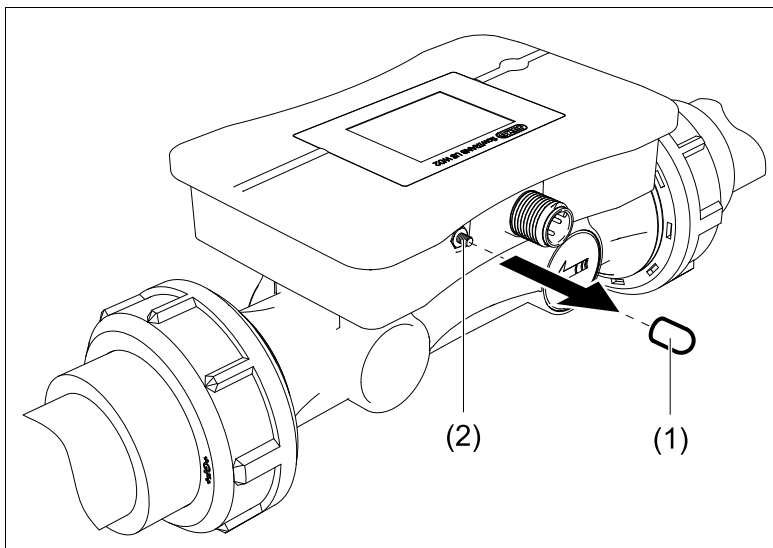

2. Plug the ring cable lug of the grounding cable (3) onto the grounding terminal and secure with the hexagon nut (4).

Tightening torque: 0.4 Nm.

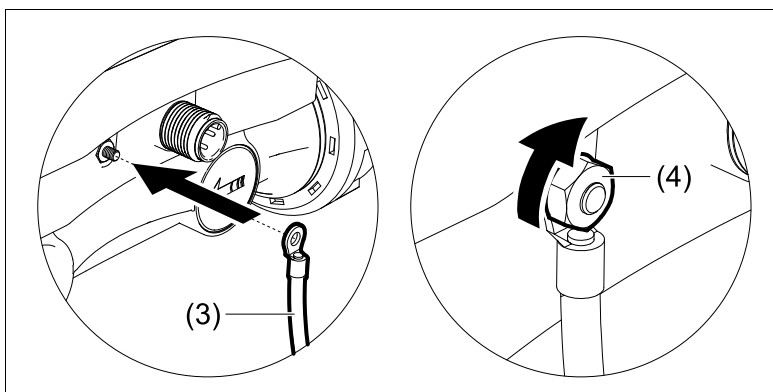

## 6 Electrical connection

3. Insert the connecting cable (5) into the M12 plug connection (6).

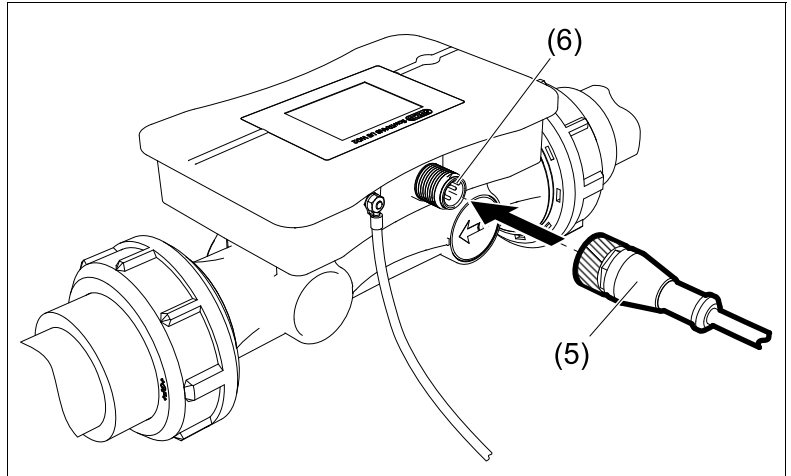

4. Screw the union nut (7) of the connecting cable onto the M12 plug connection.

Tightening torque: 0.4 Nm.

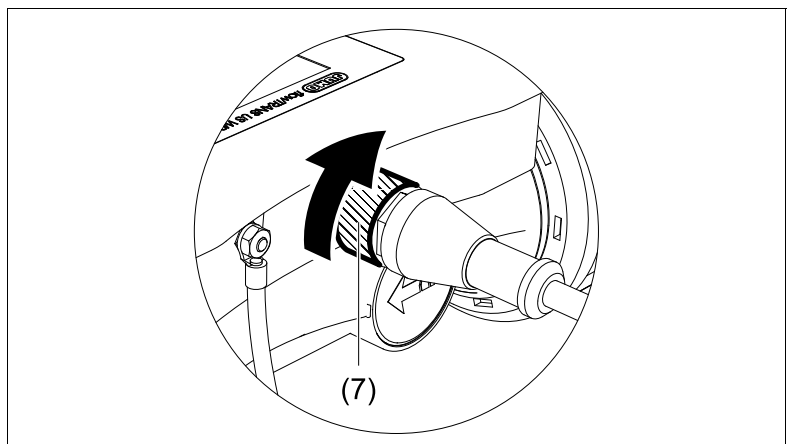

5. Connect the connecting cable to the device that is processing the signals and to the voltage supply.
  6. Lay the connecting cable and the grounding cable so that they are protected from mechanical load.
- The device is ready for operation as soon as the voltage supply is established,  
⇒ "Startup display ", Page 30.

# 7 Operation

## 7.1 Display elements

### 7.1.1 Startup display

The startup display appears on the display as soon as the voltage supply to the device is established. The startup display switches to the process display after approximately five seconds.

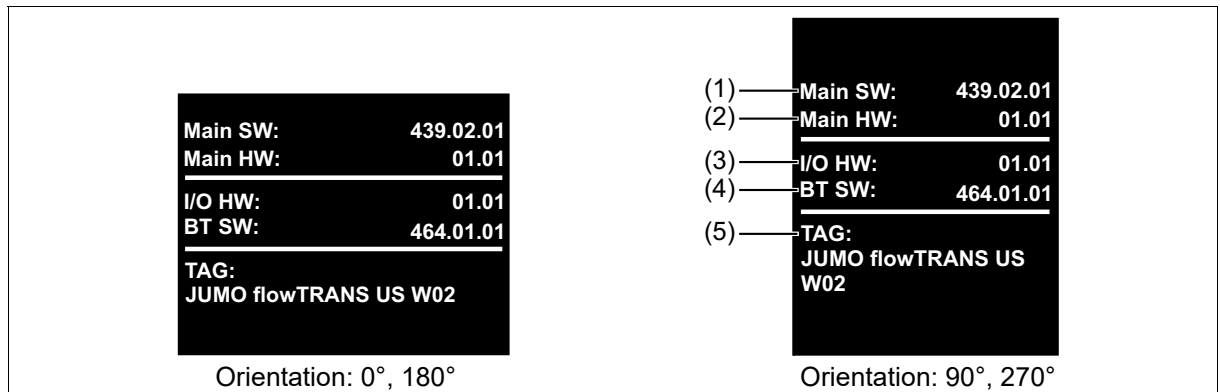

Pos.	Designation	Description
1	<b>Startup display</b>	Shows the device software version.
2, 3		Shows the device hardware version.
4		Shows the Bluetooth module software version.
5		Shows the device TAG (application-spec. marking).

### 7.1.2 Process display

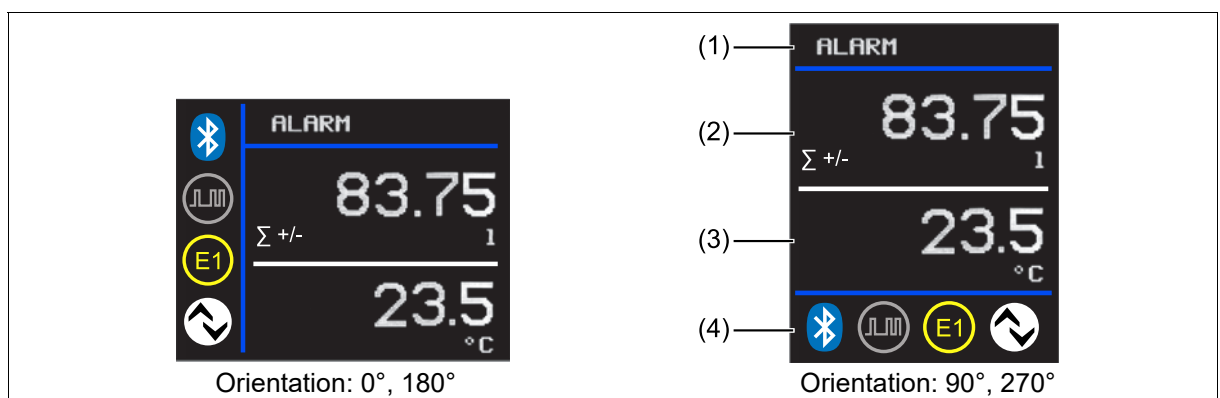

Pos.	Designation	Description
1	<b>Status bar</b>	Shows information about the device status.
2, 3	<b>Process value display 1, process value display 2</b>	Show the following values and messages: <ul style="list-style-type: none"> <li>Both configured process values (actual values)</li> <li>The process value system units</li> <li>The totalizer for the totalizer function</li> <li>The fill volume or residual volume for the batch function</li> <li>Error messages, ⇒ "Troubleshooting ", Page 62</li> </ul>
4	<b>Toolbar</b>	Shows: <ul style="list-style-type: none"> <li>The configuration and status of I/O pin 1 and I/O pin 2</li> <li>The configuration and status of the interface connections</li> </ul>

## Status bar

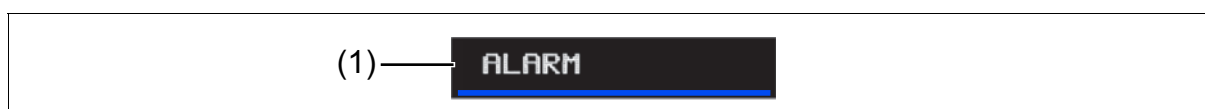

Pos.	Symbol, display	Description
1	ALARM	Shows a device error or a warning.
	BATCH	Shows an active batch operation.
	SIM	Shows an input that is in simulation mode.

## Process value display 1, Process value display 2

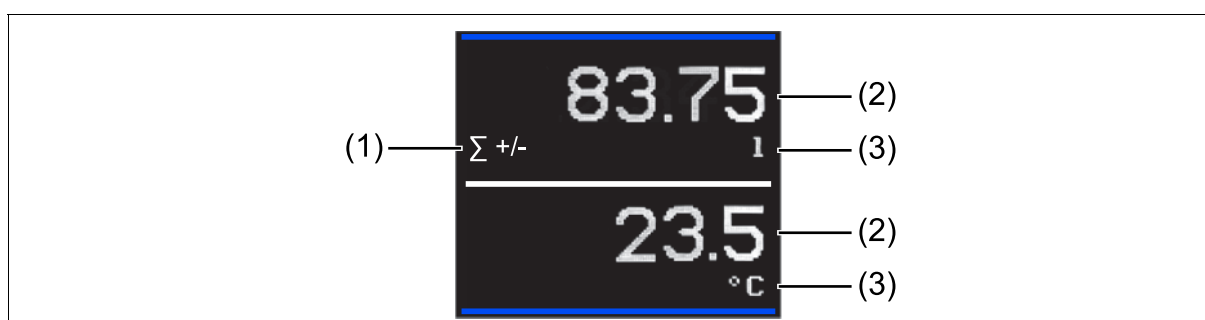

## Totalizer, totalizer transmission

Only appears if the process value display is configured accordingly.

Pos.	Symbol, display	Description
1		Shows negative count mode of the totalizer.
		Shows positive count mode of the totalizer.
		Shows balanced count mode of the totalizer.

## Batch

Only appears if the process value display is configured accordingly.

Pos.	Symbol, display	Description
1		Shows the fill volume.
		Shows the remaining volume.

## Process value (5-digit)

If the process value exceeds the 5-digit display range, the number of decimal places for the process value is reduced.

Pos.	Symbol, display	Description
2	12345	Shows the positive process value.
	-12345	Shows the negative process value.

# 7 Operation

## System unit

Pos.	Symbol, display	Description
3	l/s, m <sup>3</sup> /h, ft <sup>3</sup> /min, l/min, ft <sup>3</sup> /h, usgal/min, impgal/min, l/h, cm <sup>3</sup> /s, usgal/h, impgal/h, °C, °F, mbar, bar, psi, m/s, %, l, usgal, impgal, m <sup>3</sup> , ft <sup>3</sup>	Shows the configured system unit of the process value.

## Toolbar

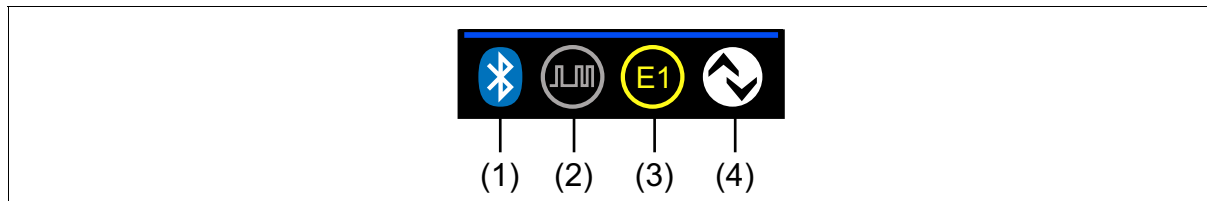





## Interface connections

Pos.	Symbol, display	Description
1		Interface connection: Bluetooth Status: Inactive
		Interface connection: Bluetooth Flashing status: Wait for connection to establish. Permanent status: Active
4		Interface connection: IO-Link Status: Inactive
		Interface connection: IO-Link Status: Active





## I/O Pin 1

Shows the configuration, function and status of the device **I/O Pin 1**.

Pos.	Symbol, display	Description
2		Configuration: IO-Link
		Configuration: Analog output
		Configuration: Digital output Function: Switching output, pulse output Status: Inactive (switching output)
		Configuration: Digital output Function: Switching output Status: Active

## I/O Pin 2

Shows the configuration, function and status of the device **I/O Pin 2**.

Pos.	Symbol, display	Description
3		Configuration: Analog output
		Configuration: Digital output Function: Switching output Status: Inactive
		Configuration: Digital output Function: Switching output Status: Active
		Configuration: Digital input Status: Inactive
		Configuration: Digital input Status: Active

# 7 Operation

## 7.2 Interfaces

### 7.2.1 Bluetooth

The JUMO smartCONNECT app allows the device to be configured and its parameters to be set using an end device. Configuration data and device information are transmitted via Bluetooth. The Bluetooth radio module of the device is permanently active during initial startup.

The app is available for free download from the [manufacturer's websites](#) or alternatively using the QR code:

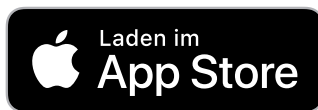

#### Bluetooth® mode

**Active:** The Bluetooth® radio module is permanently active. The device is detected by the smartCONNECT app as soon as it is within range of the Bluetooth® radio module.

**Restricted (via NFC):** The Bluetooth® radio module is inactive and can be temporarily activated via an NFC tag in the device. To establish a connection between the NFC tag and the end device, this device must be NFC-capable and held close to the device display.

**Inactive:** The Bluetooth® radio module can be disabled and enabled via IO-Link.

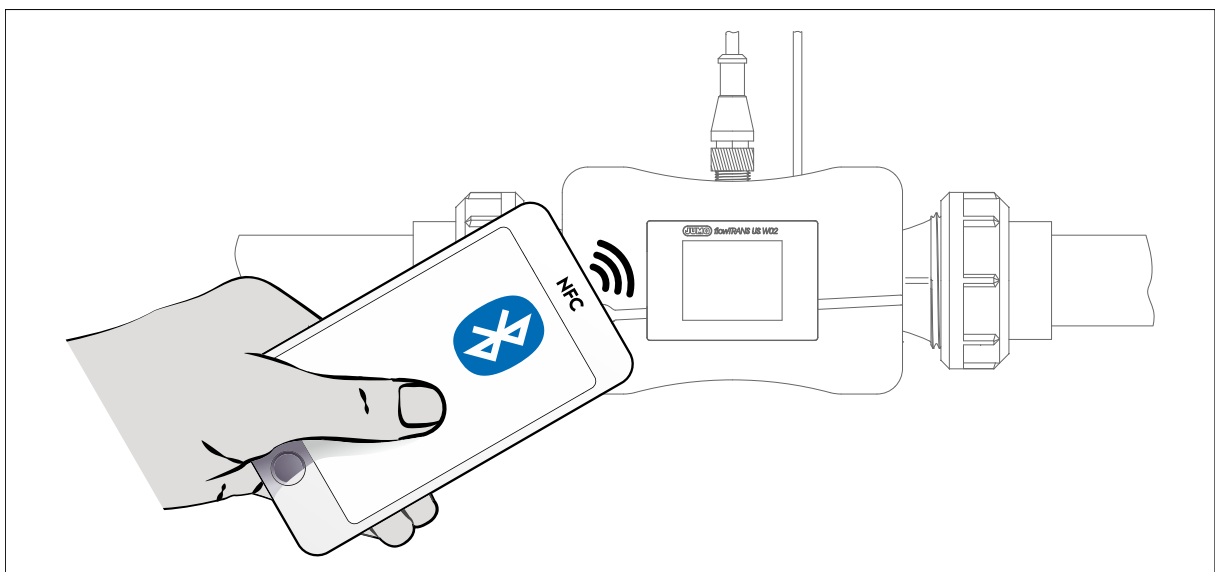

### 7.2.2 IO-Link

IO-Link enables the device to be configured and parameterized using an end device. Process data, configuration data and device information are transmitted using a standard IO-Link master.

The user software of the IO-Link master requires a device description file (IODD) for this, which is assigned to the device ID, ⇒ Seite 11.

The device IODD collection is available to download for free from the [manufacturer website](#) or alternatively directly via <http://ioddfinder.io-link.com>.

## 8.1 Switching points

### 8.1.1 Limit value function

#### Hysteresis function

Function chart

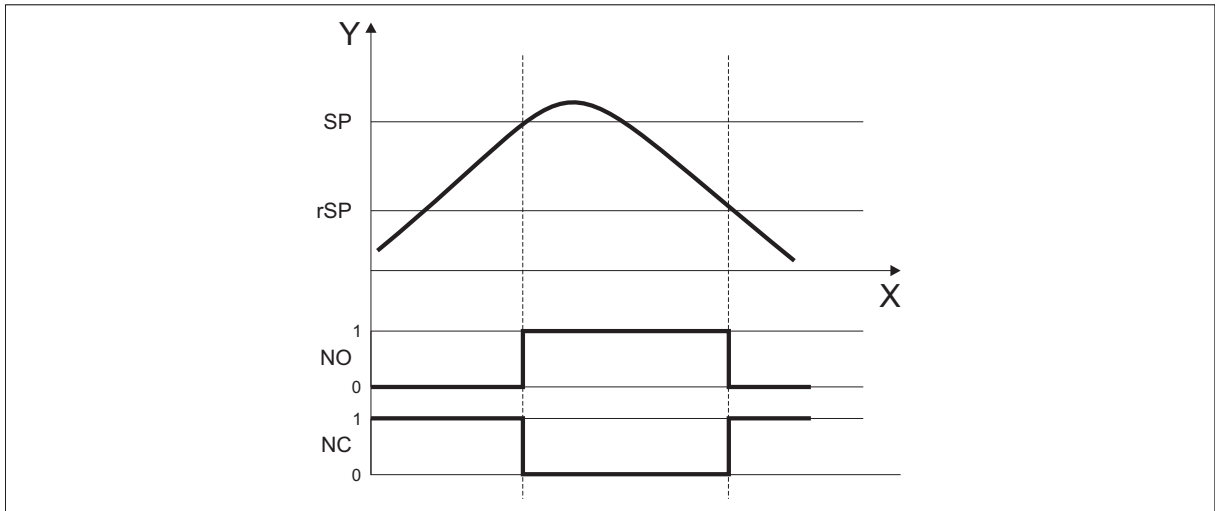

X	Time	rSP	Release point/window low
Y	Measured value	NO	Hysteresis function, NO contact
SP	Switching point/window high	NC	Hysteresis function, NC contact

#### Window function

Function chart

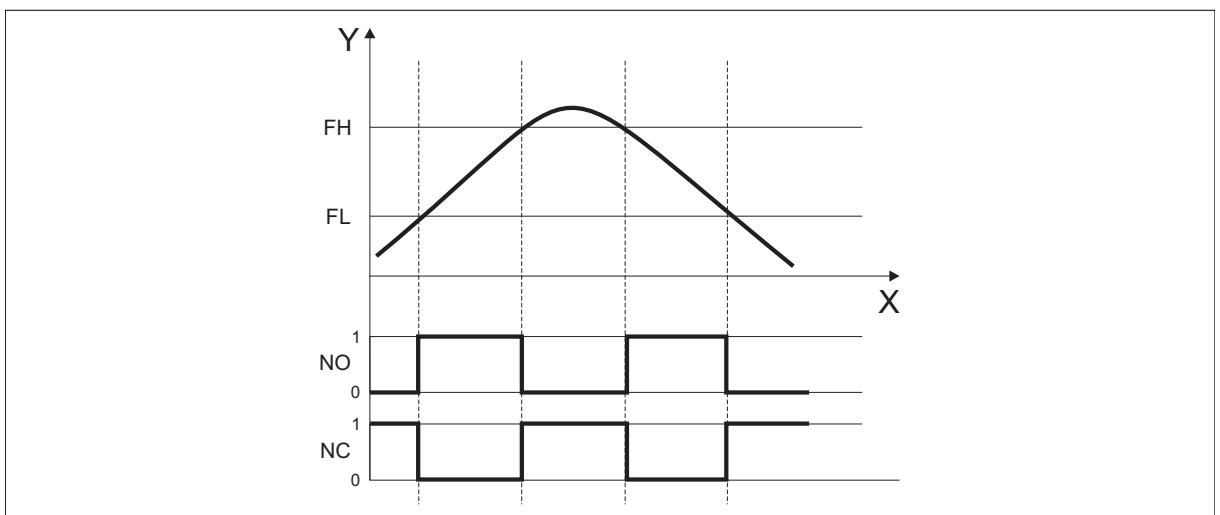

X	Time	FL	Release point/window low
Y	Measured value	NO	Window function, NO contact
FH	Switching point/window high	NC	Window function, NC contact

The switching points have a defined symmetrical hysteresis of  $\pm 0.25\%$  of the measuring range.

## 8 Device functions

### 8.1.2 Switch-on delay/switch-off delay

The delay times prevent the output from being switched by measured value peaks or by measured value dips.

Function chart

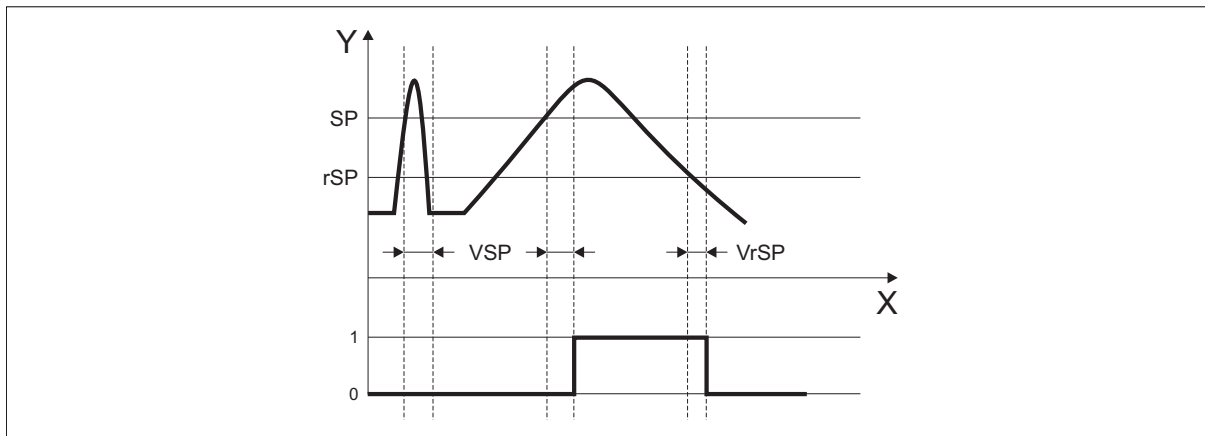

X Time

Y Measured value

SP Switching point

rSP Release point

VSP Switch-on delay

VrSP Switch-off delay

### 8.2 Measured value suppression

The function is activated via a voltage signal at the digital input.

Behavior in the event of an active function:

- No process value is output at the display and the outputs.
- The totalizers do not total any volume.
- The batch function does not add any volume.

## 8.3 Low flow suppression

The function defines a limit value as a threshold. The process value "0" is output below this threshold. A hysteresis can be configured above this threshold.

### Function chart

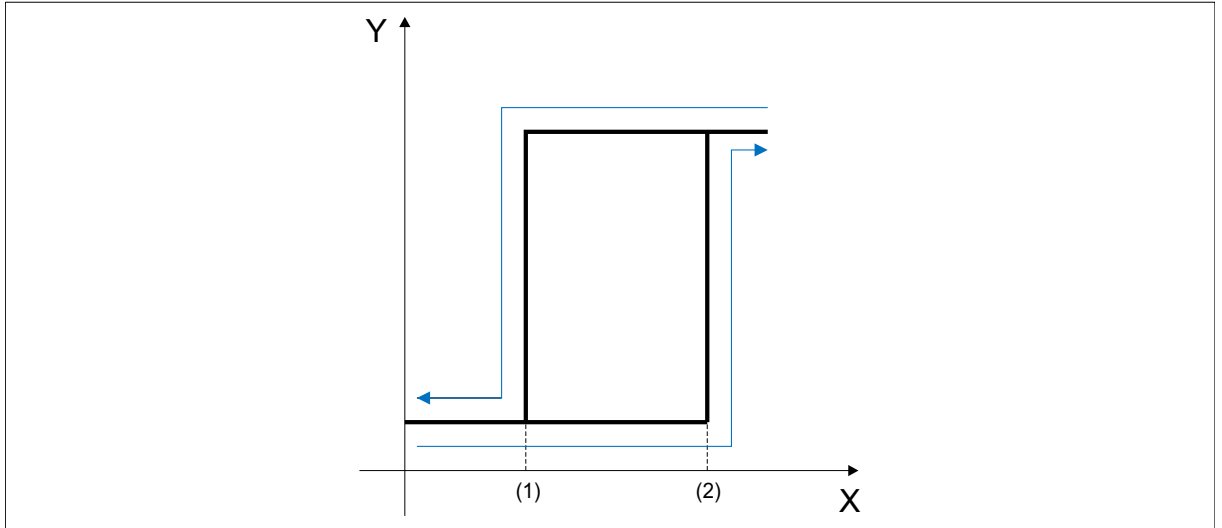

X Flow input signal  
Y Flow output signal

1 Low flow limit value  
2 Low flow hysteresis

# 8 Device functions

## 8.4 Fine adjustment

The fine adjustment is a linearization in the two-point form and influences the slope of the characteristic line and its intersection with the X-axis.

The function adjusts the measured value retrospectively to customer-specific environmental influences and does not have any effect on the default calibration data.

There are two calibrations:

- The measured value and the reference value are input.
- The plant travels to two measured values, which are saved via a command. The reference values are input.

### Example

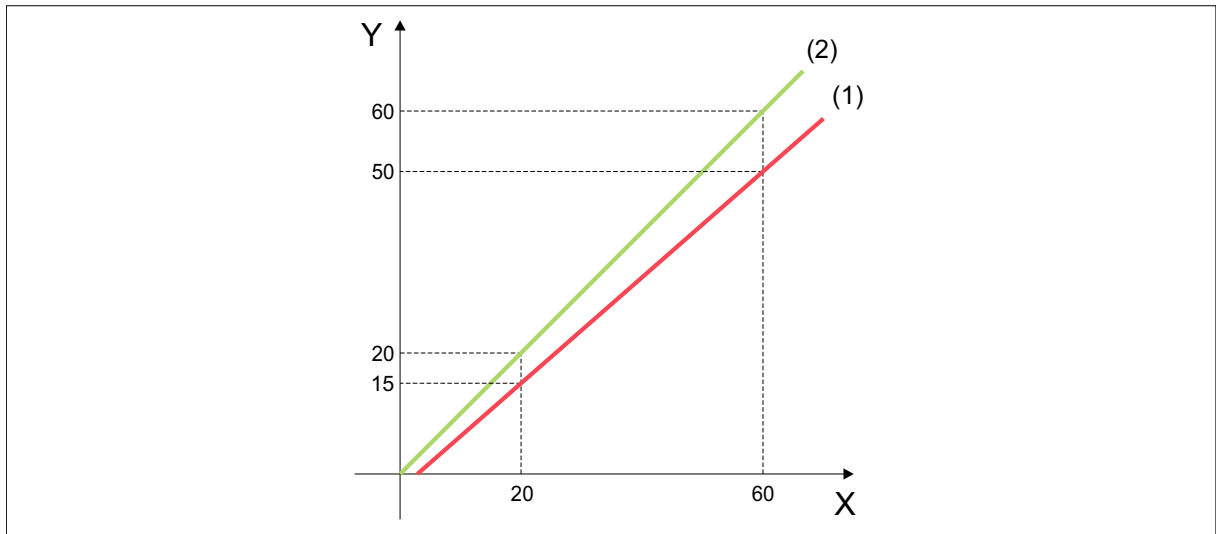

X	Reference value (TARGET start value/TARGET end value)	1	Characteristic line before fine adjustment
		2	Characteristic line after fine adjustment
Y	Measured value (ACTUAL start value/ACTUAL end value)		

## 8.5 Totalizer

### Features

- The function is active during device startup.
- There are a total of three counting modes. One counting mode for positive flow components, one counting mode for negative flow components, and one balanced counting mode that offsets the positive and negative flow components.
- From a counter reading > 99.999, the transmission is increased by 1 and the totalizer is reset to 0.
- The system unit of the totalizer can be changed in active operation.

### Behavior during a power off event

The totalized volumes are persistently saved at 15-minute intervals. The most recently saved counter reading is retained and continued during power on. The totalized volumes may deviate from the actual volume accordingly.

## 8.6 Batch

The function indicates volume quantities that have flowed through in a positive and negative flow direction and subtracts them cyclically from the specific filling volume.

### Function chart

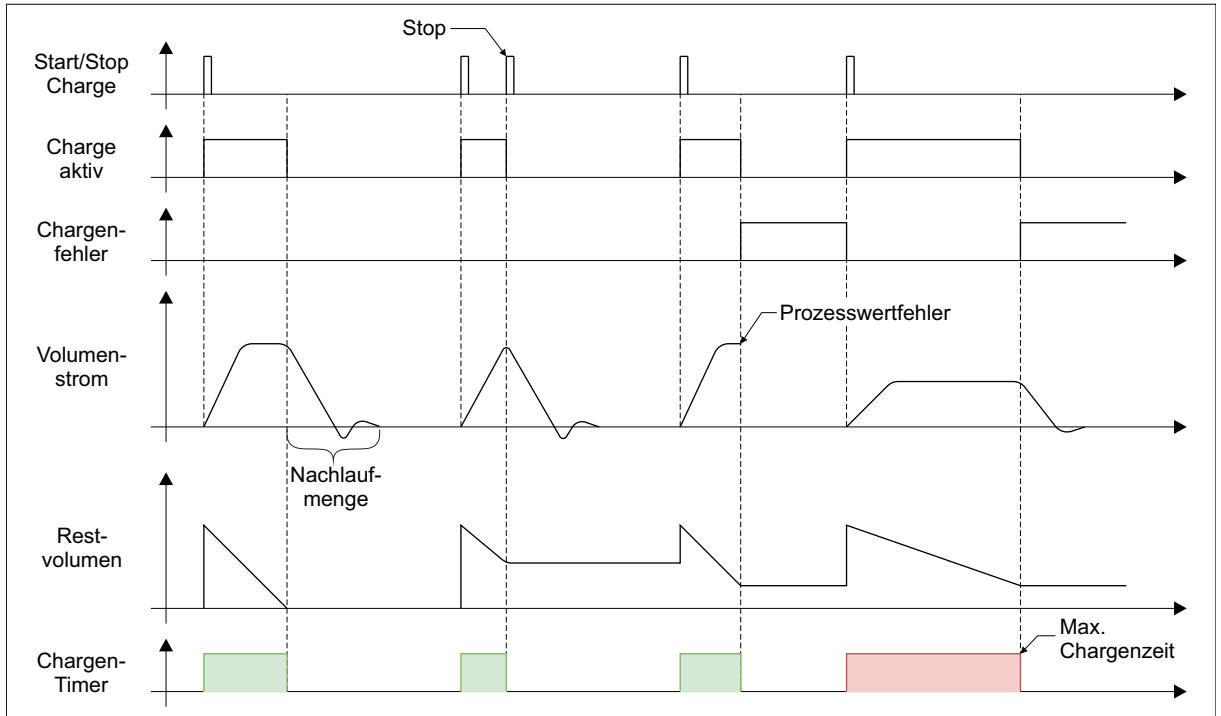

### Max. batch time

The parameter is an optional batch timer. When the **max. batch time** elapses and before the specified filling volume has been reached, the batch is deactivated and a batch error is output, ⇒ "Error messages outside NAMUR ", Page 65.

### Power off event

If an active batch is interrupted by a power off event, corresponding filling and residual volume values are lost and are reset to the default setting during power on.

## 9 Configuration via Bluetooth®

The parameter lists are based on the JUMO smartCONNECT app operating menu. The table headings locate the respective parameters in the app operating menu..

The default settings are shown in **bold** in the following tables.

### 9.1 Basic settings

#### Sensor > display

Parameter	Value	Description
Language	<b>German</b> , English, French, Spanish	National language for the device texts of the process display.
Process value 1, process value 2	No signal, <b>flow</b> , <b>temperature</b> , pressure, sound velocity, signal strength, fill volume, residual volume, totalizer 1 volume, totalizer 1 volume transmission, totalizer 2 volume, totalizer 2 volume transmission	Parameter output values (can be configured independently of one another).
Brightness	0 to 15 ( <b>8</b> )	Brightness of the process display backlight.
Rotation	<b>0°</b> , 90°, 180°, 270°	Process display alignment.

#### Sensor

Parameter	Value	Description
Application-specific marking	<b>JUMO flowTRANS US W02</b>	TAG designation (text entry with max. 32 characters possible).
Bluetooth® mode	Restricted (via NFC), <b>active</b>	Status of the Bluetooth® connection, ⇒ Seite 32.
Default settings	<b>Inactive</b> , reset	Resets the device to the default settings.

#### System units

Parameter	Value	Description
Flow	l/s, <b>l/min</b> , l/h, cm <sup>3</sup> /s, m <sup>3</sup> /h, ft <sup>3</sup> /min, ft <sup>3</sup> /h, usgal/min, usgal/h, imp.gal/min, imp.gal/h	System unit for these parameters.
Volume	cm <sup>3</sup> , <b>l</b> , m <sup>3</sup> , ft <sup>3</sup> , usgal, imp.gal	
Pressure	<b>bar</b> , mbar, psi	
Totalizer	cm <sup>3</sup> , <b>l</b> , m <sup>3</sup> , ft <sup>3</sup> , usgal, imp.gal	
Temperature	<b>°C</b> , °F	Unit for this parameter in the process value display. The output signal is always output in °C regardless of this setting.

## 9 Configuration via Bluetooth®

### Input/output 1

Parameter	Value	Description
I/O pin 1	<b>IO-Link</b> , analog output, digital output	Parameter function.

### Input/output 1 > IO-Link

Parameter	Value	Description
Application-specific marking	<b>JUMO flowTRANS US W02</b>	TAG designation (text entry with max. 32 characters possible).
System designation	***	
Location identification code	***	
Process data format	<b>Floating point</b> , whole number	IO-Link output format of process data.
Activate event	<b>Inactive</b> ; Process Data (PD) invalid; Device (D) defective; D defective & PD invalid; Application-spec. Events (AE); AE & PD invalid; AE & D defective; AE, D defective & PD invalid	Events are passed on to the IO-Link master. Determine measures on an application-specific basis.

### Input/output 1 > analog output 1

Parameter	Value	Description
Function	Inactive, <b>current output</b> , voltage output	Parameter function. Parameter <b>I/O pin 1</b> must be configured as an <b>analog output</b> value.
Output signal	<b>Flow</b> , temperature, pressure	Parameter output signal.
Scale start	Input range: -99999 to 99999 ( <b>0.000</b> )	Process value for the current output (4 mA) or the voltage output (0 V).
Scale end	Input range: -99999 to 99999 ( <b>flow<sub>max</sub> of the device</b> )	Process value for the current output (20 mA) or the voltage output (10 V).
Error behavior	<b>Low</b> , high, frozen, replacement value	Output signal in the event of a malfunction: Low: 3.4 mA or 0 V High: 22 mA or 11 V Frozen: Last valid value Replacement value: Specified replacement value
Replacement value	Input range: 0.000 to 22.00 mA ( <b>3.400</b> )	Parameter <b>error behavior</b> must be configured as a replacement value. Input range: 3.4 to 22 mA (current output) 0 to 11 V (voltage output)

## 9 Configuration via Bluetooth®

### Input/output 1 > digital output 1

Parameter	Value	Description
Function	Inactive, switching output, <b>pulse output</b>	Parameter function. Parameter <b>I/O pin 1</b> must be configured as a <b>digital output</b> value.

### Input/output 1 > digital output 1 > switching output

Parameter	Value	Description
Output signal	<b>Limit value switch</b> , batch active, batch error, device error	Parameter function. Parameter <b>I/O pin 1</b> must be configured as a <b>digital output</b> value. Parameter <b>function</b> of digital output 1 must be configured as a <b>switching output</b> value.
Inversion	On, <b>Off</b>	Inverts the output signal.
Output signal type	p-switching, n-switching, <b>push-pull</b>	Parameter function.
Limit value monitoring function	<b>Inactive</b> , hysteresis function NO contact, hysteresis function NC contact, window function NO contact, window function NC contact	Parameter function. Inactive: Switching output function inactive.
Limit value monitoring function signal	<b>Flow</b> , temperature, pressure	Process value signal of the limit value monitoring function.
Switching point/window high	Input range: -99999 to 99999 ( <b>75.00</b> )	Process value of the limit value monitoring function signal.
Release point/window low	Input range: -99999 to 99999 ( <b>50.00</b> )	
Switch-on delay	Input range: <b>0.000</b> to 100.0	—
Switch-off delay	Input range: <b>0.000</b> to 100.0	
Error behavior 	<b>Inactive</b> , active, frozen	Behavior of the output signal in case of a malfunction.

#### Error behavior

**Inactive** value: If the **function** parameter of digital output 1 is configured as a **switching output** value, a process value error sets the **switching output** value to **inactive**.

**Frozen** value: If the **function** parameter of digital output 1 is configured as a **switching output** value, a process value error does not have any influence on the configuration of the **switching output** value.

## 9 Configuration via Bluetooth®

### Input/output 1 > digital output 1 > pulse output

Parameter	Value	Description
Output signal type	p-switching, n-switching, <b>push-pull</b>	Parameter function. Parameter <b>I/O pin 1</b> must be configured as a <b>digital output</b> value. Parameter <b>function</b> of digital output 1 must be configured as a <b>pulse output</b> value.
Pulses per unit	Input range: 1 to 100000 ( <b>Output value at nominal width</b> )	Output value in pulses per volume unit (system unit of the <b>volume</b> parameter).

### Input/output 2

Parameter	Value	Description
I/O pin 2	Analog output, <b>digital output</b> , digital input	Parameter function.

### Input/output 2 > analog output 2

Parameter	Value	Description
Function	Inactive, <b>current output</b> , voltage output	Parameter function. Parameter <b>I/O pin 2</b> must be configured as an <b>analog output</b> value.
Output signal	<b>Flow</b> , temperature, pressure	Parameter output signal.
Scale start	Input range: -99999 to 99999 ( <b>0.000</b> )	Process value for the current output (4 mA) or the voltage output (0 V).
Scale end	Input range: -99999 to 99999 ( <b>flow<sub>max</sub> of the device</b> )	Process value for the current output (20 mA) or the voltage output (10 V).
Error behavior	<b>Low</b> , high, frozen, replacement value	Output signal in the event of a malfunction: Low: 3.4 mA or 0 V High: 22 mA or 11 V Frozen: Last valid value Replacement value: Input value for the parameter <b>replacement value</b>
Replacement value	Input range: 0.000 to 22.00 ( <b>3.400</b> )	<b>Error behavior</b> parameter must be configured as a <b>replacement value</b> . Input range: 3.4 to 22 mA (current output) 0 to 11 V (voltage output)

## 9 Configuration via Bluetooth®

### Input/output 2 > digital output 2

Parameter	Value	Description
Function	Inactive, <b>switching output</b>	Parameter function. Parameter <b>I/O pin 2</b> must be configured as a <b>digital output</b> value.

### Input/output 2 > digital output 2 > switching output

Parameter	Value	Description
Output signal	<b>Limit value switch</b> , batch active, batch error, device error	Parameter function. Parameter <b>I/O pin 2</b> must be configured as a <b>digital output</b> value. Parameter <b>function</b> of digital output 2 must be configured as a <b>switching output</b> value.
Inversion	On, <b>Off</b>	Inverts the output signal.
Output signal type	p-switching, n-switching, <b>push-pull</b>	Parameter function.
Limit value monitoring function	Inactive, <b>hysteresis function NO contact</b> , hysteresis function NC contact, window function NO contact, window function NC contact	Parameter function. Inactive: Switching output function inactive.
Limit value monitoring function signal	<b>Flow</b> , temperature, pressure	Process value signal of the limit value monitoring function.
Switching point/window high	Input range: -99999 to 99999 ( <b>75.00</b> )	Process value of the limit value monitoring function signal.
Release point/window low	Input range: -99999 to 99999 ( <b>50.00</b> )	
Switch-on delay	Input range: <b>0.000</b> to 100.0	—
Switch-off delay	Input range: <b>0.000</b> to 100.0	
Error behavior 	<b>Inactive</b> , active, frozen	Behavior of the output signal in case of a malfunction.

#### Error behavior

**Inactive** value: If the **function** parameter of digital output 2 is configured as a **switching output**, a process value error sets this value to **inactive**.

**Frozen** value: If the **function** parameter of digital output 1 is configured as a **switching output** value, a process value does not have any influence on the configuration of this value.

## 9 Configuration via Bluetooth®

### Input/output 2 > digital input

Parameter	Value	Description
Function	<b>Inactive</b> , reset all totalizers, start/stop batch, measured value suppression	Function of the parameter in the event of signaling at the digital input.
Inversion	On, <b>Off</b>	Inverts the input signal.

### Measurands > flow

Parameter	Value	Description
Filter time constant	Input range: 0.000 to 25.00 ( <b>0.450</b> )	Optimization of measured value updating. The higher the filter time constant value, the slower the change in measured value at the output. Response time $t_{90}$ with default setting: $\leq 2$ s.
Low flow limit value	Input range: 0.000 to 10.00 ( <b>0.050</b> )	Input value in % of $flow_{max}$ of nominal width (DN) of the device. No process value is output below the limit value.
Low flow hysteresis	Input range: 0.000 to 50.00 ( <b>10.00</b> )	Input value in % of the low flow. Sets hysteresis of low flow.
Inversion	On, <b>Off</b>	Inverts the flow signal, e.g. if the device has been installed in negative flow direction.
Characteristic line	<b>Standard</b> , user-defined 1 to 9	Standard: Water User-defined 1 to 9: Not defined

## 9 Configuration via Bluetooth®

### Measurands > flow > fine adjustment

Parameter	Value	Description
Function	On, <b>Off</b>	Parameter function.
ACTUAL start value	Input range: -99999 to 99999 ( <b>0.000</b> )	Input value for fine adjustment. Alternatively: parameter <b>adoption of ACTUAL start value</b>
ACTUAL end value	Input range: -99999 to 99999 ( <b>100.0</b> )	Input value for fine adjustment. Alternatively: parameter <b>adoption of ACTUAL end value</b>
TARGET start value	Input range: -99999 to 99999 ( <b>0.000</b> )	Input value for fine adjustment.
TARGET end value	Input range: -99999 to 99999 ( <b>100.0</b> )	
Adoption of ACTUAL start value	<b>Inactive</b> , apply ACTUAL start value	Travel to ACTUAL start value and use <b>apply ACTUAL start value</b> to apply the measured flow value. Alternatively: parameter <b>ACTUAL start value</b>
Adoption of ACTUAL end value	<b>Inactive</b> , apply ACTUAL end value	Travel to <b>ACTUAL</b> end value and use <b>apply ACTUAL end value</b> to apply the measured flow value. Alternatively: Parameter <b>ACTUAL end value</b>

### Measurands > temperature

Parameter	Value	Description
Filter time constant	Input range: 0.000 to 25.00 ( <b>1.000</b> )	Optimization of measured value updating. The higher the filter time constant value, the slower the change in measured value at the output.
Offset	Input range: -10.00 to 10.00 ( <b>0.000</b> )	Offset correction for zero point adjustment.

### Measurands > pressure

Parameter	Value	Description
Filter time constant	Input range: 0.000 to 25.00 ( <b>1.000</b> )	Optimization of measured value updating. The higher the filter time constant value, the slower the change in measured value at the output.
Offset	Input range: -10000 up to 10000 ( <b>0.000</b> )	Offset correction for zero point adjustment.

## 9 Configuration via Bluetooth®

### Totalizer

Parameter	Value	Description
Counting mode totalizer 1	<b>Positive</b> , negative, balanced	Integrate the flow components depending on the counting modes.
Counting mode totalizer 2	Positive, negative, <b>balanced</b>	Positive: Only positive flow components. Negative: Only negative flow components. Balanced: Positive and negative flow components.
Reset all totalizers	<b>Inactive</b> , reset	All totalizers and transmissions are reset.

### Batch

Parameter	Value	Description
Volume	Input range: 0.000 to 99999 ( <b>100.0</b> )	Input value of the volume to be filled in the system unit of the totalizer.
Max. batch time	Input range: <b>0</b> to 9999	If the input value is exceeded, the batch is aborted.

### Simulation > flow

Parameter	Value	Description
Simulation	On, <b>Off</b>	Parameter function.
Value	Input range: -99999 up to 99999 ( <b>0.000</b> )	Input value for the simulation.

### Simulation > temperature

Parameter	Value	Description
Simulation	On, <b>Off</b>	Parameter function.
Value	Input range: -99999 up to 99999 ( <b>0.000</b> )	Input value for the simulation.

### Simulation > pressure

Parameter	Value	Description
Simulation	On, <b>Off</b>	Parameter function.
Value	Input range: -99999 up to 99999 ( <b>0.000</b> )	Input value for the simulation.

## 9 Configuration via Bluetooth®

---

### 9.2 Functions

#### 9.2.1 Switching points

Hysteresis function, window function, switch-on delay/switch-off delay

##### Input/output 1/2

Parameter	Value	Description
I/O pin 1/2	Digital output	

##### Input/output 1/2 > digital output 1/2

Parameter	Value	Description
Function	Switching output	

##### Input/output 1/2 > digital output 1/2 > switching output

Parameter	Value	Description
Output signal	Limit value switch	
Limit value monitoring function	Hysteresis function, NO contact; hysteresis function, NC contact	
	Window function, NO contact; window function, NC contact	
Limit value monitoring function signal	Flow, temperature, pressure	
Switching point/window high	-99999 to 99999	Switching condition: switching point/window high $\geq$ release point/window low
Release point/window low	-99999 to 99999	
Switch-on delay	0.000 to 100.0	
Switch-off delay	0.000 to 100.0	

#### 9.2.2 Measured value suppression

##### Input/output 2

Parameter	Value	Description
I/O pin 2	Digital input	

##### Input/output 2 > digital input

Parameter	Value	Description
Function	Measured value suppression	

#### 9.2.3 Low flow suppression

##### Measurands > flow

Parameter	Value	Description
Low flow limit value	Parameter value	
Low flow hysteresis	Parameter value	

## 9.2.4 Fine adjustment

### Measurands > flow > fine adjustment

Manual fine adjustment

Parameter	Value	Description
Function	Off, On	On: Activating fine adjustment Off: Resetting fine adjustment
ACTUAL start value	Parameter value	
ACTUAL end value	Parameter value	
TARGET start value	Parameter value	
TARGET end value	Parameter value	
Adoption of ACTUAL start value	Inactive	
Adoption of ACTUAL end value	Inactive	

### Measurands > flow > fine adjustment

Automatic fine adjustment

Parameter	Value	Description
Function	Off, On	On: Activating fine adjustment Off: Resetting fine adjustment
ACTUAL start value		After configuration, <b>adoption of ACTUAL start value/ACTUAL end value</b> : travel to values in the plant.
ACTUAL end value		
TARGET start value	Parameter value	
TARGET end value	Parameter value	
Adoption of ACTUAL start value	Apply	
Adoption of ACTUAL end value	Apply	

## 9.2.5 Totalizer

### Measurands > flow

Parameter	Value	Description
Counting mode totalizer 1/2	Positive, negative, balanced	
Reset all totalizers	Reset	Manual reset

### Input/output 2

Parameter	Value	Description
I/O pin 2	Digital input	

### Input/output 2 > digital input

Parameter	Value	Description
Function	Reset all totalizers	

## 9 Configuration via Bluetooth®

---

### 9.2.6 Batch function

#### Input/output 1

Parameter	Value	Description
I/O pin 1	Digital output	

#### Input/output 1 > digital output 1

Parameter	Value	Description
Function	Switching output	

#### Input/output 1 > digital output 1 > switching output

Parameter	Value	Description
Output signal	Batch active	

#### Input/output 2

Parameter	Value	Description
I/O pin 2	Digital input	

#### Batch

Parameter	Value	Description
Volume	Parameter value	Filling volume
Max. batch time	Parameter value	Optional extra

#### Input/output 2 > digital input

Parameter	Value	Description
Function	Start/stop batch, inactive	

#### Sensor > display

Parameter	Value	Description
Process value 1/2	Filling volume, residual volume	Optional extra, displays the process values in the device display

The default settings are shown in **bold** in the following tables.

## Sensor > display

Parameter	Value	Description	Index	Sub-index	Data type	Access right <sup>a</sup>
Language	<b>German</b> , English, French, Spanish	National language for the device texts of the process display.	420	0	Enum	RW
Process value 1, process value 2	No signal, <b>flow</b> , <b>temperature</b> , pressure, sound velocity, signal strength, fill volume, residual volume, totalizer 1 volume, totalizer 2 volume, totalizer 2 volume transmission	Parameter output values (can be configured independently of one another).	421..422	0	Enum	RW
Brightness	0 to 15 ( <b>8</b> )	Brightness of the process display backlight.	423	0	Uint16	RW
Rotation	<b>0°</b> , 90°, 180°, 270°	Process display alignment.	424	0	Enum	RW

<sup>a</sup> RW = Read and write access, RO = Read-only access, WO = Write-only access

## Sensor

Parameter	Value	Description	Index	Sub-index	Data type	Access right <sup>a</sup>
Application-specific marking	<b>JUMO flowTRANS US W02</b>	TAG designation (text entry with max. 32 characters possible).	24	0	String	RW
Bluetooth® mode	Restricted (via NFC), <b>active</b>	Status of the Bluetooth® connection, ⇨ Seite 32.	440	0	Enum	RW
Default settings	<b>Inactive</b> , reset	Resets the device to the default settings.	2	0	-	WO

<sup>a</sup> RW = Read and write access, RO = Read-only access, WO = Write-only access

## System units

Parameter	Value	Description	Index	Sub-index	Data type	Access right <sup>a</sup>
Flow	l/s, <b>l/min</b> , l/h, cm <sup>3</sup> /s, m <sup>3</sup> /h, ft <sup>3</sup> /min, ft <sup>3</sup> /h, usgal/min, usgal/h, imp.gal/min, imp.gal/h	System unit for this parameter.	121	0	Enum	RW
Volume	cm <sup>3</sup> , l, m <sup>3</sup> , ft <sup>3</sup> , usgal, imp.gal					
Pressure	<b>bar</b> , mbar, psi					
Totalizer	cm <sup>3</sup> , l, m <sup>3</sup> , ft <sup>3</sup> , usgal, imp.gal					

# 10 Configuration via IO-Link

Parameter	Value	Description	Index	Sub-index	Data type	Access right <sup>a</sup>
Temperature	°C, °F	Unit for this parameter in the process value display. The output signal is always output in °C regardless of this setting.	425	0	Enum	RW

<sup>a</sup> RW = Read and write access, RO = Read-only access, WO = Write-only access

## Input/output 1

Parameter	Value	Description	Index	Sub-index	Data type	Access right <sup>a</sup>
I/O pin 1	IO-Link, analog output, digital output	Parameter function.	65	0	Enum	RW

<sup>a</sup> RW = Read and write access, RO = Read-only access, WO = Write-only access

## Input/output 1 > IO-Link

Parameter	Value	Description	Index	Sub-index	Data type	Access right <sup>a</sup>
Application-specific marking	JUMO flowTRANS US W02	TAG designation (text entry with max. 32 characters possible).	24	0	String	RW
System designation	***		25	0	String	RW
Location identification code	***		26	0	String	RW
Process data format	Floating point, whole number	IO-Link output format of process data.	64	0	Enum	RW
Activate event	Inactive; Process Data (PD) invalid; Device (D) defective; D defective & PD invalid; Application-spec. Events (AE); AE & PD invalid; AE & D defective; AE, D defective & PD invalid	Events are passed on to the IO-Link master. Determine measures on an application-specific basis.	111	0	UInt8	RW

<sup>a</sup> RW = Read and write access, RO = Read-only access, WO = Write-only access

## Input/output 1 > analog output 1

Parameter	Value	Description	Index	Sub-index	Data type	Access right <sup>a</sup>
Function	Inactive, <b>current output</b> , voltage output	Parameter function. Parameter <b>I/O pin 1</b> must be configured as an <b>analog output</b> value.	261	0	Enum	RW
Output signal	<b>Flow</b> , temperature, pressure	Parameter output signal.	260	0	Enum	RW
Scale start	Input range: -99999 to 99999 ( <b>0.000</b> )	Process value for the current output (4 mA) or the voltage output (0 V).	262	0	Float	RW
Scale end	Input range: -99999 to 99999 ( <b>flow<sub>max</sub> of the device</b> )	Process value for the current output (20 mA) or the voltage output (10 V).	263	0	Float	RW
Error behavior	<b>Low</b> , high, frozen, replacement value	Output signal in the event of a malfunction: Low: 3.4 mA or 0 V High: 22 mA or 11 V Frozen: Last valid value. Replacement value: Specified replacement value.	264	0	Enum	RW
Replacement value	Input range: 0.000 to 22.00 ( <b>3.4</b> )	Parameter <b>error behavior</b> must be configured as a replacement value. Input range: 3.4 to 22 mA (current output) 0 to 11 V (voltage output)	265	0	Float	RW

<sup>a</sup> RW = Read and write access, RO = Read-only access, WO = Write-only access

## Input/output 1 > digital output 1

Parameter	Value	Description	Index	Sub-index	Data type	Access right <sup>a</sup>
Function	Inactive, switching output, <b>pulse output</b>	Parameter function. Parameter <b>I/O pin 1</b> must be configured as a <b>digital output</b> value.	200	0	Enum	RW

<sup>a</sup> RW = Read and write access, RO = Read-only access, WO = Write-only access

# 10 Configuration via IO-Link

## Input/output 1 > digital output 1 > switching output

Parameter	Value	Description	Index	Sub-index	Data type	Access right <sup>a</sup>
Output signal	<b>Limit value switch</b> , batch active, batch error, device error	Parameter function. Parameter <b>I/O pin 1</b> must be configured as a <b>digital output</b> value. Parameter <b>function</b> of digital output 1 must be configured as a <b>switching output</b> value.	201	0	Enum	RW
Inversion	<b>Off</b> , On	Inverts the output signal.	202	0	Enum	RW
Output signal type	p-switching, n-switching, <b>push-pull</b>	Parameter function.	203	0	Enum	RW
Limit value monitoring function	<b>Inactive</b> , hysteresis function NO contact, hysteresis function NC contact, window function NO contact, window function NC contact	Parameter function. Inactive: Switching output function inactive.	205	0	Enum	RW
Limit value monitoring signal	<b>Flow</b> , temperature, pressure	Process value signal of the limit value monitoring function.	206	0	Enum	RW
Switching point/window high	Input range: -99999 to 99999 ( <b>75</b> )	Process value of the limit value monitoring function signal.	207	0	Float	RW
Release point/window low	Input range: -99999 to 99999 ( <b>50</b> )		208	0	Float	RW
Switch-on delay	Input range: <b>0.000</b> to 100.0	-	209	0	Float	RW
Switch-off delay	Input range: <b>0.000</b> to 100.0		210	0	Float	RW
Error behavior 	<b>Inactive</b> , active, frozen	Behavior of the output signal in case of a malfunction.	211	0	Enum	RW

<sup>a</sup> RW = Read and write access, RO = Read-only access, WO = Write-only access

### Error behavior

**Inactive** value: If the **function** parameter of digital output 1 is configured as a **switching output** value, a process value error sets the **switching output** value to **inactive**.

**Frozen** value: If the **function** parameter of digital output 1 is configured as a **switching output** value, a process value error does not have any influence on the configuration of the **switching output** value.

## Input/output 1 > digital output 1 > pulse output

Parameter	Value	Description	Index	Sub-index	Data type	Access right <sup>a</sup>
Output signal type	p-switching, n-switching, <b>push-pull</b>	Parameter function. Parameter <b>I/O pin 1</b> must be configured as a <b>digital output</b> value.	203	0	Enum	RW
Pulses per unit	Input range: 1 to 100000( <b>Output value at nominal width</b> )	Parameter <b>function</b> of digital output 1 must be configured as a <b>pulse output</b> value. Output value in pulses per volume unit (system unit of the <b>volume</b> parameter).	204	0	Uint32	RW

<sup>a</sup> RW = Read and write access, RO = Read-only access, WO = Write-only access

## Input/output 2

Parameter	Value	Description	Index	Sub-index	Data type	Access right <sup>a</sup>
I/O pin 2	Analog output, <b>digital output</b> , digital input	Parameter function.	66	0	Enum	RW

<sup>a</sup> RW = Read and write access, RO = Read-only access, WO = Write-only access

## Input/output 2 > analog output 2

Parameter	Value	Description	Index	Sub-index	Data type	Access right <sup>a</sup>
Function	Inactive, <b>current output</b> , voltage output	Parameter function. Parameter <b>I/O pin 2</b> must be configured as an <b>analog output</b> value.	281	0	Enum	RW
Output signal	<b>Flow</b> , temperature, pressure	Parameter output signal.	280	0	Enum	RW
Scale start	Input range: -99999 to 99999 ( <b>0.000</b> )	Process value for the current output (4 mA) or the voltage output (0 V).	282	0	Float	RW
Scale end	Input range: -99999 to 99999 ( <b>flow<sub>max</sub> of the device</b> )	Process value for the current output (20 mA) or the voltage output (10 V).	283	0	Float	RW

# 10 Configuration via IO-Link

Parameter	Value	Description	Index	Sub-index	Data type	Access right <sup>a</sup>
Error behavior	Low, high, frozen, replacement value	Output signal in the event of a malfunction: Low: 3.4 mA or 0 V High: 22 mA or 11 V Frozen: Last valid value. Replacement value: Input value for the parameter.	284	0	Enum	RW
Replacement value	Input range: 0.000 to 22.00 (3.4)	<b>Error behavior</b> parameter must be configured as a <b>replacement value</b> . Input range: 3.4 to 22 mA (current output) 0 to 11 V (voltage output)	285	0	Float	RW

<sup>a</sup> RW = Read and write access, RO = Read-only access, WO = Write-only access

## Input/output 2 > digital output 2

Parameter	Value	Description	Index	Sub-index	Data type	Access right <sup>a</sup>
Function	Inactive, <b>switching output</b>	Parameter function. Parameter <b>I/O pin 2</b> must be configured as a <b>digital output</b> value.	220	0	Enum	RW

<sup>a</sup> RW = Read and write access, RO = Read-only access, WO = Write-only access

## Input/output 2 > digital output 2 > switching output

Parameter	Value	Description	Index	Sub-index	Data type	Access right <sup>a</sup>
Output signal	<b>Limit value switch</b> , batch active, batch error, device error	Parameter function. Parameter <b>I/O pin 2</b> must be configured as a <b>digital output</b> value. Parameter <b>function</b> of digital output 2 must be configured as a <b>switching output</b> value.	221	0	Enum	RW
Inversion	<b>Off</b> , On	Inverts the output signal.	222	0	Enum	RW
Output signal type	p-switching, n-switching, <b>push-pull</b>	Parameter function.	223	0	Enum	RW

Parameter	Value	Description	Index	Sub-index	Data type	Access right <sup>a</sup>
Limit value monitoring function	Inactive, <b>hysteresis function NO contact</b> , hysteresis function NC contact, window function NO contact, window function NC contact	Parameter function. Inactive: Switching output function inactive.	225	0	Enum	RW
Limit value monitoring function signal	<b>Flow</b> , temperature, pressure	Process value signal of the limit value monitoring function.	226	0	Enum	RW
Switching point/window high	Input range: -99999 to 99999 ( <b>75</b> )	Process value of the limit value monitoring function signal.	227	0	Float	RW
Release point/window low	Input range: -99999 to 99999 ( <b>50</b> )		228	0	Float	RW
Switch-on delay	Input range: <b>0.000</b> to 100.0	–	229	0	Float	RW
Switch-off delay	Input range: <b>0.000</b> to 100.0		230	0	Float	RW
Error behavior 	<b>Inactive</b> , active, frozen	Behavior of the output signal in case of a malfunction.	231	0	Enum	RW

<sup>a</sup> RW = Read and write access, RO = Read-only access, WO = Write-only access

## Error behavior

**Inactive** value: If the **function** parameter of digital output 2 is configured as a **switching output**, a process value error sets this value to **inactive**.

**Frozen** value: If the **function** parameter of digital output 1 is configured as a **switching output** value, a process value does not have any influence on the configuration of this value.

## Input/output 2 > digital input

Parameter	Value	Description	Index	Sub-index	Data type	Access right <sup>a</sup>
Function	<b>Inactive</b> , reset all totalizers, start/stop batch, measured value suppression	Function of the parameter in the event of signaling at the digital input.	301	0	Enum	RW
Inversion	<b>On, Off</b>	Inverts the input signal.	300	0	Enum	RW

<sup>a</sup> RW = Read and write access, RO = Read-only access, WO = Write-only access

# 10 Configuration via IO-Link

## Measurands > flow

Parameter	Value	Description	Index	Sub-index	Data type	Access right <sup>a</sup>
Filter time constant	Input range: 0.000 to 25.00 ( <b>0.450</b> )	Optimization of measured value updating. The higher the filter time constant value, the slower the change in measured value at the output.	120	0	Float	RW
Low flow limit value	Input range: 0.000 to 10.00 ( <b>0.050</b> )	Response time $t_{90}$ with default setting: $\leq 2$ s. Input value in % of flow <sub>max</sub> of nominal width (DN) of the device. No process value is output below the limit value.	124	0	Float	RW
Low flow hysteresis	Input range: 0.000 to 50.00 ( <b>10</b> )	Input value in % of the low flow. Sets hysteresis of low flow.	125	0	Float	RW
Inversion	<b>Off</b> , On	Inverts the flow signal, e.g. if the device has been installed in negative flow direction.	126	0	Enum	RW
Characteristic line	<b>Standard</b> , user-defined 1 to 9	Standard: Water User-defined 1 to 9: Not defined.	128	0	Enum	RW

<sup>a</sup> RW = Read and write access, RO = Read-only access, WO = Write-only access

## Measurands > flow > fine adjustment

Parameter	Value	Description	Index	Sub-index	Data type	Access right <sup>a</sup>
Function	On, <b>Off</b>	Parameter function.	320	0	Enum	RW
ACTUAL start value	Input range: -99999 to 99999 ( <b>0.000</b> )	Input value for fine adjustment. Alternatively: parameter <b>adoption of ACTUAL start value</b>	321	0	Float	RW
ACTUAL end value	Input range: -99999 to 99999 ( <b>100.0</b> )	Input value for fine adjustment. Alternatively: parameter <b>adoption of ACTUAL end value</b>	322	0	Float	RW
TARGET start value	Input range: -99999 to 99999 ( <b>0.000</b> )	Input value for fine adjustment.	323	0	Float	RW
TARGET end value	Input range: -99999 to 99999 ( <b>100.0</b> )	Input value for fine adjustment.	324	0	Float	RW

Parameter	Value	Description	Index	Sub-index	Data type	Access right <sup>a</sup>
Adoption of ACTUAL start value	<b>Inactive</b> , apply ACTUAL start value	Travel to ACTUAL start value and use <b>apply ACTUAL start value</b> to apply the measured flow value. Alternatively: parameter <b>ACTUAL start value</b>	2	0	–	WO
Adoption of ACTUAL end value	<b>Inactive</b> , apply ACTUAL end value	Travel to <b>ACTUAL end value</b> and use <b>apply ACTUAL end value</b> to apply the measured flow value. Alternatively: Parameter <b>ACTUAL end value</b>	2	0	–	WO

<sup>a</sup> RW = Read and write access, RO = Read-only access, WO = Write-only access

## Measurands > temperature

Parameter	Value	Description	Index	Sub-index	Data type	Access right <sup>a</sup>
Filter time constant	Input range: 0.000 to 25.00 ( <b>1.000</b> )	Optimization of measured value updating. The higher the filter time constant value, the slower the change in measured value at the output.	140	0	Float	RW
Offset	Input range: -10.00 to 10.00 ( <b>0.000</b> )	Offset correction for zero point adjustment.	141	0	Float	RW

<sup>a</sup> RW = Read and write access, RO = Read-only access, WO = Write-only access

## Measurands > pressure

Parameter	Value	Description	Index	Sub-index	Data type	Access right <sup>a</sup>
Filter time constant	Input range: 0.000 to 25.00 ( <b>1.000</b> )	Optimization of measured value updating. The higher the filter time constant value, the slower the change in measured value at the output.	161	0	Float	RW
Offset	Input range: -10000 up to 10000 ( <b>0.000</b> )	Offset correction for zero point adjustment.	162	0	Float	RW

<sup>a</sup> RW = Read and write access, RO = Read-only access, WO = Write-only access

# 10 Configuration via IO-Link

## Totalizer

Parameter	Value	Description	Index	Sub-index	Data type	Access right <sup>a</sup>
Counting mode totalizer 1	Positive, negative, balanced	Integrate the flow components depending on the counting modes. Positive: Only positive flow components. Negative: Only negative flow components. Balanced: Positive and negative flow components.	340	0	Enum	RW
Counting mode totalizer 2	Positive, negative, <b>balanced</b>		360	0	Enum	RW
Reset all totalizers	Reset: 180	All totalizers and transmissions are reset.	2	0	-	WO

<sup>a</sup> RW = Read and write access, RO = Read-only access, WO = Write-only access

## Batch

Parameter	Value	Description	Index	Sub-index	Data type	Access right <sup>a</sup>
Volume	Input range: 0.000 to 99999 (100.0)	Input value of the volume to be filled in the system unit of the totalizer. If the input value is exceeded, the batch is aborted.	380	0	Float	RW
Max. batch time	Input range: 0 to 9999		381	0	Float	RW
Start/stop batch	Start/stop: 170	The batch can be started or stopped using commands from the IO-Link or digiLine/Modbus interfaces.	2	0	-	WO

<sup>a</sup> RW = Read and write access, RO = Read-only access, WO = Write-only access

## Simulation > flow

Parameter	Value	Description	Index	Sub-index	Data type	Access right <sup>a</sup>
Simulation Value	Off, On Input range: -99999 to 99999 (0.000)	Parameter function. Input value for the simulation.	1520	0	Enum	RW
			127	0	Float	RW

<sup>a</sup> RW = Read and write access, RO = Read-only access, WO = Write-only access

## Simulation > temperature

Parameter	Value	Description	Index	Sub-index	Data type	Access right <sup>a</sup>
Simulation	On, Off	Parameter function.	1521	0	Enum	RW
Value	Input range: -99999 to 99999 (0.000)	Input value for the simulation.	142	0	Float	RW

<sup>a</sup> RW = Read and write access, RO = Read-only access, WO = Write-only access

## Simulation > pressure

Parameter	Value	Description	Index	Sub-index	Data type	Access right <sup>a</sup>
Simulation	On, Off	Parameter function.	1522	0	Enum	RW
Value	Input range: -99999 to 99999 (0.000)	Input value for the simulation.	163	0	Float	RW

<sup>a</sup> RW = Read and write access, RO = Read-only access, WO = Write-only access

# 11 Troubleshooting

---

## 11.1 Process value error

Process value errors are displayed flashing instead of the process value. With error messages in line with the NAMUR classification NE 107, process value errors are supplemented by symbols and a two-line message (alternating with the process display).

Appearance	Cause	Remedy
----	No process value signal is configured.	Configure a process value signal.
	The process value signal is faulty.	At device restart: Wait for initialization (max. 15 s). At device restart, and with the batch function activated: Execute batch.
	Internal device error	Contact the manufacturer.
+++++	The temperature sensor is faulty.	Contact the manufacturer.
<<<<<	The measuring range was undershot.	Operate the device within the device specifications.
>>>>>	The measuring range was exceeded.	Operate the device within the device specifications.

## 11.2 Error messages in line with NAMUR

Error messages in line with NAMUR classification NE 107 are displayed by symbols and a two-line message (alternating with the process display).

Symbol	Designation
	Error/failure

Message	Cause	Remedy	Process value status in PDI (1 byte)	Event code	Event configurable	Event type
Internal error (TDC comm.)	The device is faulty.	Contact the manufacturer.	Bit2	0x1000	Yes	Error
Flow invalid	Too many air bubbles in the system. The sensor is faulty.	Bleed the system. Contact the manufacturer.	Bit2 Bit2	0x1000 0x1000	Yes Yes	Error Error
Temperature invalid	The measuring range has been fallen below/exceeded. The sensor is faulty.	Comply with measuring range. Contact the manufacturer.	– Bit3	0x8C20 0x1000	Yes Yes	Error Error
Pressure invalid	The measuring range has been fallen below/exceeded. The sensor is faulty.	Comply with measuring range. Contact the manufacturer.	– Bit4	0x8C20 0x1000	Yes Yes	Error Error
Configuration corrupted	The configuration data in the EEPROM are damaged.	Contact the manufacturer. Transfer the configuration data to the device again.	Bit10	0x6320	No	Error
Device not calibrated	The device is not calibrated The device is faulty.	Contact the manufacturer.	Bit11	0x5000	Yes	Error

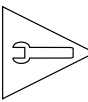
Symbol	Designation
	Functional check

Message	Cause	Remedy	Process value status in PDI (1 byte)	Event code	Event configurable	Event type
Simulation active	Simulation mode is active.	Deactivate simulation mode. Alternatively: Restart device.	–	–	–	–

# 11 Troubleshooting

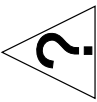
Symbol		Designation				
		Outside the specification				
		Message	Cause	Remedy	Process value status in PDI (1 byte)	Event code
Outside the specification	Flow: The measuring range was exceeded.	Comply with measuring range.	–	0x8C10	Yes	Warning
	Temperature: The measuring range has been fallen below/exceeded.					
	Pressure: The measuring range has been fallen below/exceeded.					
Undervoltage	The voltage supply to the device is insufficient.	Check the voltage supply to the device.	–	0x5111	No	Warning
Overload at C/Q or DO	The switching outputs are overloaded.	Check the connection and load of the switching outputs.	–	–	–	–
Error analog output	The burden at the analog output is too high.	Observe the specified values for the burden of the analog output.	–	–	–	–
Max. pulse freq. exceeded	The maximum output frequency of the pulse output has been exceeded.	Check the configuration of the pulse output.	–	–	–	–
Empty conduit	The meter run is empty.	Fill the meter run or the system.	Bit6	0x8CA0	Yes	Warning
Air bubbles detected	Air bubbles have been detected in the system.	Bleed the system.	Bit7	0x8CA1	No	Warning

## 11.3 Error messages outside NAMUR

Error messages outside NAMUR classification NE 107 and additional information are displayed by symbols and a two-line message (alternating with the process display).

Symbol	Designation					
	Caution					
Error message	Cause	Remedy	Process value status in PDI (1 byte)	Event code	Event user configurable	Event type
Batch error	The maximum batch time has been exceeded.	Check the filling volume of the batch and restart the process.	Bit9	0x8CA2	Yes	Warning
	A measurement error occurred during the batch.	Check the process for measurement errors and restart the process.				
Batch	The batch is active.	–	Bit8	0x8CA3	Yes	Information

# 12 Maintenance and cleaning

---

## 12.1 Cleaning device housing

The device housing can be cleaned when the device has been installed.  
Clean the device with a cloth dampened with water.

## 12.2 Decontamination

Use:

- When the medium is changed in the plant.
- Before replacing O-rings.
- Before returning the device.
- Before disposing of the device.

Requirements:

- The device is uninstalled, ⇒Page 67.
- If the medium is a hazardous substance: The information in the safety data sheet is taken into account.
- Suitable protective equipment has been set up.
- Ein geeignetes Reinigungsmittel ist einsatzbereit.
- Ein Reinigungsplatz zum Spülen und Neutralisieren aller medienberührten Teile ist vorbereitet.

Procedure:

1. **CAUTION!** Do not damage the sealing ring grooves of the process connections when removing the O-rings.  
Remove the two O-rings from the sealing ring grooves.
2. **CAUTION!** Use only cleaning agents that are compatible with the materials used to make the device.  
Thoroughly flush and neutralize all parts that come into contact with the medium using a suitable cleaning agent.
3. When disposing the device: ⇒Page 67.
4. When continuing to use the device: ⇒Page 66.

## 12.3 Replacing O-rings

Requirements:

- All components in contact with the medium are decontaminated, ⇒Page 66.

Procedure:

1. Check the O-rings previously used for damage and replace if necessary.
2. Install the device, ⇒Page 24.

## 13.1 Uninstallation

Requirements:

- The system has been de-energized and secured against being switched on again.
- The medium circulation of the plant is stopped.
- The pipe is drained and rinsed.
- Suitable protective equipment has been set up.
- A clean and dry storage location has been prepared.

Procedure:

1. Manually loosen the union nut of the connecting cable from the M12 plug connection on the device.
2. Pull the connecting cable out of the M12 plug connection and remove from the working range.
3. Release the hexagon nut from the grounding terminal.
4. Remove the grounding cable from the grounding terminal and remove from the working range.
5. Manually loosen the union nuts from the process connections on the device and slide over the ends of the pipe.
6. **CAUTION!** Make sure that the O-rings remain in the sealing ring grooves of the process connections of the device.

Carefully remove the device from the plant and put in a clean and dry place.

## 13.2 Returns

Requirements:

- Clean the device housing ⇒Page 66.
- Clean the parts that come into contact with the medium ⇒Page 66.

Procedure:

1. The [supplementary sheet for product returns](#) must first be completed correctly and signed. Then enclose it with the shipping documents and attach it to the packaging, ideally on the outside.
2. Use the original packaging or a suitably secure container for sending the device.

## 13.3 Disposal

Requirements:

- Clean the device housing ⇒Page 66.
- Clean the parts that come into contact with the medium ⇒Page 66.



- Do not dispose of the device or replaced parts in the trash after use.
- Delete programs and data stored on the device.
- Remove batteries, if any, if this can be done without damaging the device.
- Dispose of the device and the packaging material in a responsible and environmentally friendly manner.
- Observe the country-specific laws and regulations for waste treatment and disposal.

In accordance with Directive 2012/19/EU on Waste from Electrical and Electronic Equipment, manufacturers are obliged to offer the option of returning waste equipment. Request the return from the manufacturer.

# 14 Accessories

## Without UL approval

Designation	Part no.
Mounting set PVC, DN 10 with PP nut	00750869
Mounting set PVC, DN 15 with PP nut	00750871
Mounting set PVC, DN 20 with PP nut	00750872
Mounting set PVC, DN 25 with PP nut	00750874
Mounting set PVC, DN 32 with PP nut	00750876
Mounting set PP, socket welding DN 15	00750888
Mounting set PP, socket welding DN 20	00750890
Mounting set PP, socket welding DN 25	00750927
Mounting set PP, socket welding DN 32	00750926
Mounting set PP, butt welding DN 15	00750878
Mounting set PP, butt welding DN 20	00750881
Mounting set PP, butt welding DN 25	00750884
Mounting set PP, butt welding DN 32	00750887
Mounting set stainless steel, DN 10 with PP nut	00750924
Mounting set stainless steel, DN 15 with PP nut	00750923
Mounting set stainless steel, DN 20 with PP nut	00750920
Mounting set stainless steel, DN 25 with PP nut	00750919
Mounting set stainless steel, DN 32 with PP nut	00750918
JUMO smartCONNECT (App)	00770436
IO-Link master, 1-channel (TMG Device Tool), including mini USB cable for use with Windows® PC	00694070
Line socket, 4-pole, M12 × 1, straight, length 2 m	00404585
Line socket, 4-pole, M12 × 1, angled, length 2 m	00409334

## With UL approval

Designation	Part no.
IO-Link master, 4-channel – TURCK TBEN-S2-4IOL	00759867
IO-Link master, 8-channel – TURCK TBEN-LL-8IOL	00759875
Connection line M8/voltage supply, length 2 m, IO-Link master, 4 channel	00767913
Connection line M12/voltage supply, length 2 m, IO-Link master, 8 channel	00767914
Connection line M8/Ethernet, length 2 m, IO-Link master, 4 channel	00767923
Connection line M12/Ethernet, length 2 m, IO-Link master, 8 channel	00767927
Connection line M12, M12, black, PUR, length 2 m (straight coupling/straight connector; 5 pole; A-coded)	00777804

## 15.1 China RoHS

							
产品组别 Product group: 406051		产品中有害物质的名称及含量 China EEP Hazardous Substances Information					
部件名称 Component Name							
		铅 (Pb)	汞 (Hg)	镉 (Cd)	六价铬 (Cr(VI))	多溴联苯 (PBB)	多溴二苯醚 (PBDE)
外壳 Housing (Gehäuse)		○	○	○	○	○	○
过程连接 Process connection (Prozessanschluss)		○	○	○	○	○	○
螺母 Nuts (Mutter)		○	○	○	○	○	○
螺栓 Screw (Schraube)		○	○	○	○	○	○
电路板 Circuit boards (Leiterplatte)		X	○	○	○	○	○

本表格依据SJ/T 11364的规定编制。  
This table is prepared in accordance with the provisions SJ/T 11364.

○：表示该有害物质在该部件所有均质材料中的含量均在GB/T 26572规定的限量要求以下。  
Indicate the hazardous substances in all homogeneous materials for the part are below the limit of the GB/T 26572.

×：表示该有害物质至少在该部件的某一均质材料中的含量超出GB/T 26572规定的限量要求。  
Indicate the hazardous substances in at least one homogeneous material of the part exceed the limit of the GB/T 26572.

## 15 Certificates

---





**JUMO GmbH & Co. KG**

Street address:  
Moritz-Juchheim-Straße 1  
36039 Fulda, Germany

Delivery address:  
Mackenrodtstraße 14  
36039 Fulda, Germany

Postal address:  
36035 Fulda, Germany

Phone: +49 661 6003-0  
Fax: +49 661 6003-607  
Email: [mail@jumo.net](mailto:mail@jumo.net)  
Internet: [www.jumo.net](http://www.jumo.net)

**JUMO UK LTD**

JUMO House  
Temple Bank, Riverway  
Harlow, Essex, CM20 2DY, UK

Phone: +44 1279 63 55 33  
Fax: +44 1279 62 50 29  
Email: [sales@jumo.co.uk](mailto:sales@jumo.co.uk)  
Internet: [www.jumo.co.uk](http://www.jumo.co.uk)

**JUMO Process Control, Inc.**

6724 Joy Road  
East Syracuse, NY 13057, USA

Phone: +1 315 437 5866  
Fax: +1 315 437 5860  
Email: [info.us@jumo.net](mailto:info.us@jumo.net)  
Internet: [www.jumousa.com](http://www.jumousa.com)

