

# JUMO flowTRANS US W02

Ultrasonic flow meter  
for liquids



Operating Manual



40605106T90Z001K000

V1.00/EN/00778428/2024-11-11

**Further information and downloads**



[qr-406051-en.jumo.info](https://qr-406051-en.jumo.info)

# Table of contents

---

<b>1</b>	<b>About this documentation</b>	<b>6</b>
1.1	Purpose	6
1.2	Target group	6
1.3	Definition of terms	6
1.4	Trademark information	6
1.5	Symbols	6
<b>2</b>	<b>Safety</b>	<b>7</b>
2.1	Intended use	7
2.2	Qualification of personnel	7
2.3	Hot surfaces	7
2.4	Hazardous materials	7
2.5	Mechanical loads	7
2.6	Transport and storage damage	8
<b>3</b>	<b>Description</b>	<b>9</b>
3.1	Structure	9
3.2	Function	9
3.3	Nameplate	10
3.4	Approval marks and certificates	11
3.5	Scope of delivery	11
<b>4</b>	<b>Technical data</b>	<b>12</b>
4.1	Electrical safety	12
4.2	Electrical data	12
4.3	Inputs	13
4.3.1	Measurands	13
4.4	Interfaces	14
4.4.1	Bluetooth	14
4.4.2	RS485	15
4.5	Display	15
4.6	Environmental influences	16
4.7	Mechanical features	16
4.7.1	Device	16
4.7.2	Materials	17
4.7.3	Nominal pressure	17
4.7.4	Pressure loss diagram	17
4.8	Measurement media	18
4.9	Dimensions	18
4.9.1	Device	18
4.9.2	Accessories	19

---

# Table of contents

---

<b>5</b>	<b>Installation</b>	<b>20</b>
5.1	Preparing for installation	20
5.1.1	Installation site	20
5.1.2	Inlet and outlet sections	20
5.1.3	Installation position	20
5.1.4	Avoid mechanical strain	21
5.1.5	Flow direction	21
5.1.6	Alignment of the housing for electronic components	21
5.2	Installing the device	22
<b>6</b>	<b>Electrical connection</b>	<b>23</b>
6.1	Connection elements	23
6.1.1	Terminal assignment	23
6.2	Connecting the device	24
<b>7</b>	<b>Operation</b>	<b>26</b>
7.1	Display elements	26
7.1.1	Startup display	26
7.1.2	Process display	26
7.2	Interfaces	29
7.2.1	Bluetooth	29
7.2.2	JUMO digiLine	29
<b>8</b>	<b>Configuration via Bluetooth®</b>	<b>30</b>
<b>9</b>	<b>Modbus address tables</b>	<b>34</b>
9.1	Modbus functions	34
9.2	Nameplate	35
9.3	Measuring point info	36
9.4	Configuration of the interface	36
9.5	Calibration data	37
9.5.1	Calibration logbook entry 1	37
9.5.2	Calibration logbook entry 2	38
9.5.3	Calibration logbook entry 3	39
9.5.4	Calibration logbook entry 4	40
9.5.5	Calibration logbook entry 5	41
9.5.6	Calibration logbook entry 6	42
9.5.7	Calibration logbook entry 7	43
9.5.8	Calibration logbook entry 8	44
9.5.9	Calibration logbook entry 9	45
9.5.10	Calibration logbook entry 10	46
9.6	Configuration flow	47
9.7	Configuration temperature	47

---

# Table of contents

---

9.8	Configuration pressure	.48
9.9	Configuration display	.48
9.10	Configuration reset totalizer	.49
9.11	Configuration batch	.49
9.12	Configuration Bluetooth®	.49
9.13	Configuration fine adjustment	.49
9.14	Process values	.50
9.14.1	Inputs	.50
9.14.2	Simulation	.50
9.14.3	Limit value switch	.50
9.14.4	Batch function	.51
9.14.5	Totalizer	.51
9.14.6	Batch	.51
9.14.7	Fine adjustment	.51
9.14.8	Operation hours counter	.52
9.14.9	Date and time for time stamp	.52
9.14.10	Summary of important process values	.52
9.15	Error messages	.53
<b>10</b>	<b>Troubleshooting</b>	<b>.54</b>
10.1	Process value error	.54
10.2	Error messages in line with NAMUR	.54
10.3	Error messages outside NAMUR	.55
<b>11</b>	<b>Maintenance and cleaning</b>	<b>.56</b>
11.1	Cleaning device housing	.56
11.2	Decontamination	.56
11.3	Replacing O-rings	.56
<b>12</b>	<b>Shutdown</b>	<b>.57</b>
12.1	Uninstallation	.57
12.2	Returns	.57
12.3	Disposal	.57
<b>13</b>	<b>Accessories</b>	<b>.58</b>
<b>14</b>	<b>Certificates</b>	<b>.60</b>
14.1	China RoHS	.60

---

# 1 About this documentation

---

## 1.1 Purpose

This documentation is part of the device and includes all information to ensure that it is used safely and as intended across all phases of the product lifecycle.

If you do not follow the documentation and safety information, this may result in risk to life and damage to property due to improper use.

- Read and follow the documentation and the safety information and warnings.
- Store the document in its entirety, in an easily accessible location, and so that it can be read in full at all times.
- Contact the manufacturer if you have any questions about the device and documentation.

## 1.2 Target group

This documentation is intended to be used by personnel trained in electrical, mechanical, and plant engineering across all phases of the product lifecycle.

## 1.3 Definition of terms

Use in the documentation	Definition
Device, inline device, product	Ultrasonic flowmeter
Medium, measurement medium, fluid	Liquid
Transducer	Ultrasonic converter, transducer, sensor
Volume flow, flow	Totalized flow rate per time span
Product lifecycle	Overall consideration of Product identification, acceptance of the goods, storage, mounting, connection, operation, troubleshooting, maintenance to disposal

## 1.4 Trademark information

All trademarks and trade and company names used are the property of their rightful owners or authors.

## 1.5 Symbols

### NOTE!



This symbol is used in tables and indicates that further information is provided after the table.

---

### REFERENCE!



This symbol refers to **further information** in other sections, chapters, or other manuals.

---

### 2.1 Intended use

The ultrasonic flowmeter measures the flow, temperature and (optionally) the pressure of conductive and non-conductive liquid media.

It is mounted in pipes made from plastic or metal.

The documentation is part of the device. The device is only intended for use according to this documentation.

### 2.2 Qualification of personnel

The personnel deployed must meet the following requirements in all phases of the product lifecycle:

- Trained electrical, mechanical, and plant engineering personnel.
- Members of personnel are familiar with this documentation and the safety information and warnings it contains.

### 2.3 Hot surfaces

Hot device surfaces pose a risk of injury. Hot device surfaces can be caused by the use of hot media in applications.

- If required, install contact protection.
- Take into account the alignment of the housing for electronic components, ⇒page 21.

When working on the device:

- Allow the device and plant to cool down.
- Wear suitable protective equipment.

### 2.4 Hazardous materials

Using hazardous materials as a medium may result in abrasive and corrosive damage to components of the product that come into contact with the medium. The medium may leak and present a fire hazard and a risk to health.

Carry out a risk assessment taking into consideration the safety data sheet for the relevant hazardous substance for mounting, operation, maintenance, cleaning, and disposal:

- Comparison and systematic checking of the durability of the components of the product that come into contact with the medium and the admissible environmental influences.
- Assessment of the risk to people and the environment.
- Assessment of the fire hazard due to the product materials, the admissible environmental influences, and the voltage supply.

### 2.5 Mechanical loads

Mechanical load on the device and process connections can lead to leaks.

- Do not place the device and the process connections under mechanical strain.
- Systematically check that the process connections are leak-tight.

## 2 Safety

---

### 2.6 Transport and storage damage

The device can be damaged if it is insufficiently protected during transport and/or improperly stored.

- Transport the device protected from moisture and dirt in shockproof packaging.
- Protect all electrical and mechanical connections from damage.
- Observe the admissible storage temperature of the device.
- Store the device in a dry and dust-free environment.

## 3.1 Structure

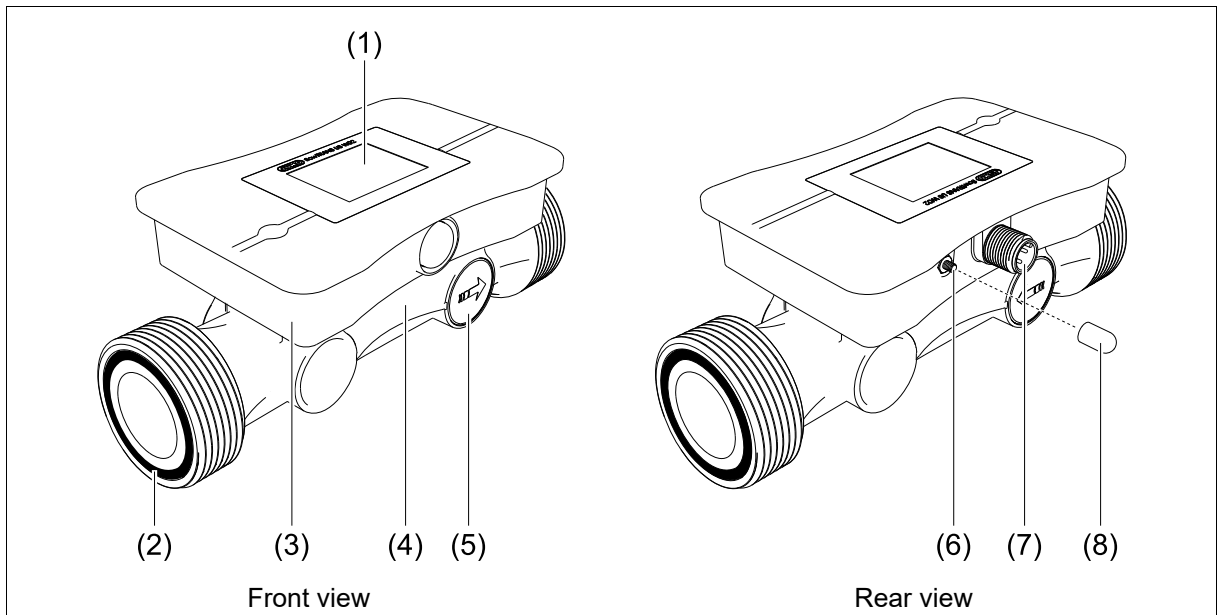

- |   |  |   |                                       |
|---|--|---|---------------------------------------|
| 1 | Display                                  | 5 | Transducer (ultrasonic converter)     |
| 2 | O-ring (seal for the process connection) | 6 | Grounding terminal                    |
| 3 | Housing for electronic components        | 7 | M12 plug connector                    |
| 4 | Measuring pipe                           | 8 | Protective cap for grounding terminal |

## 3.2 Function

The transducers are on opposite sides of the measuring section and act as transmitters and receivers, i.e. they convert the electrical energy into sound waves and the sound waves into electrical energy.

The electronic components supply power to the device, convert the raw signals into standard signals for communicating with other systems (PLC, recorder, indicating device, etc.), and provide interfaces for displaying measured values.

### Function principle

The ultrasonic flowmeter works according to the runtime method.

This method measures the runtimes  $t_1$  and  $t_2$  required by the sound to travel from transducer A to transducer B and vice versa.

→ = Flow direction

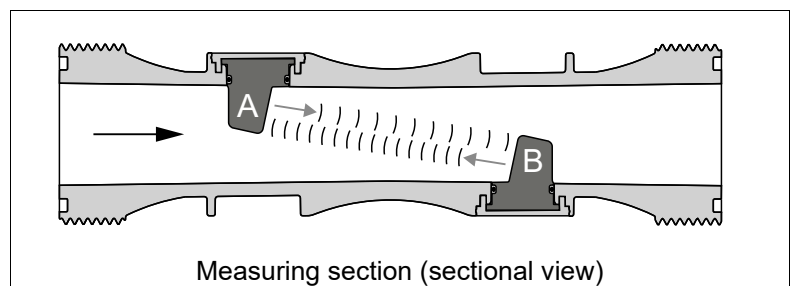

The runtime differential  $\Delta t$  is directly proportional to the flow velocity of the medium.

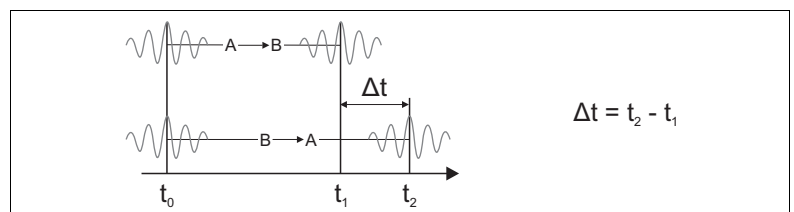

## 3 Description

### 3.3 Nameplate

Example:

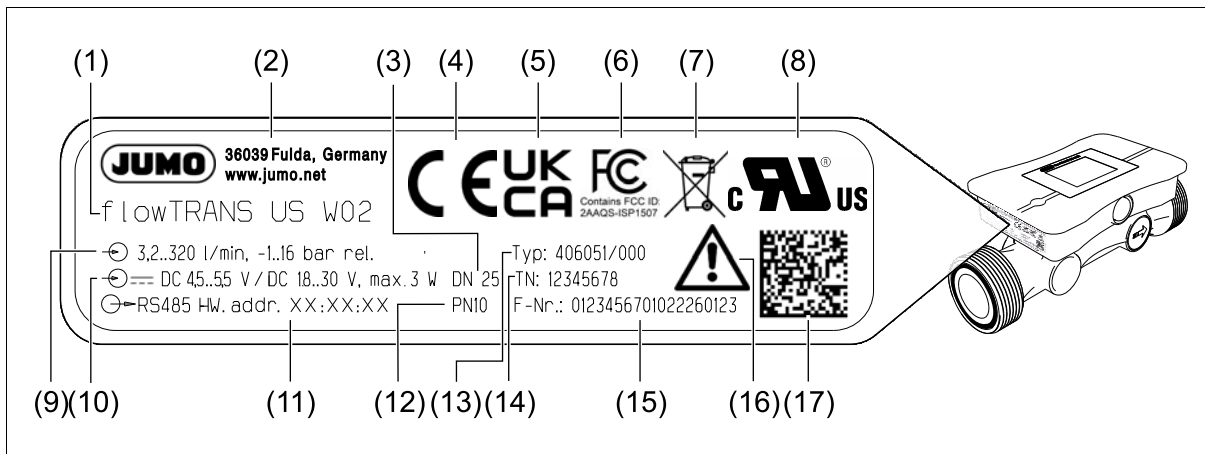

- |   |                             |    |                                |
|---|-----------------------------|----|--------------------------------|
| 1 | Device designation          | 10 | Voltage supply (DC)            |
| 2 | Manufacturer and address    | 11 | JUMO digiLine hardware address |
| 3 | Nominal width               | 12 | Nominal pressure level         |
| 4 | CE identification marking   | 13 | Order code                     |
| 5 | UKCA identification marking | 14 | Part no.                       |
| 6 | FCC identification marking  | 15 | Fabrication number             |
| 7 | Disposal                    | 16 | Observe device documentation!  |
| 8 | UL identification marking   | 17 | Data Matrix code               |
| 9 | Measuring range             |    |                                |

### 3.4 Approval marks and certificates



Certificates for approved device versions are available for download on the manufacturer's website.

#### **Federal Communications Commission (FCC)**

This device complies with part 15 of the FCC rules. Operation is subject to the following two conditions.

(1) This device may not cause harmful interference.

(2) This device must accept any interference received, including interference that may cause undesired operation.

Caution: Any Changes or modifications not expressly approved by the party responsible for compliance could void the user's authority to operate the equipment.

#### **Radio Equipment Directive (RED)**

JUMO GmbH & Co. KG hereby declares that the JUMO flowTRANS US W02 device complies with the Directive 2014/53/EU. The full text of the EU Declaration of Conformity is available at the following web address: [qr-406051-en.jumo.info](http://qr-406051-en.jumo.info).

#### **Radio equipment regulations 2017**

JUMO GmbH & Co. KG hereby states that the flowTRANS W02 device complies with the radio equipment regulations UK S.I. 2017 No. 1206. The full text of the UK Declaration of Conformity is available at the following web address: [qr-406051-en.jumo.info](http://qr-406051-en.jumo.info).

### 3.5 Scope of delivery

Device in the ordered version
Brief instructions
Calibration certificate
2 O-rings (seal for the process connection) in the ordered version

## 4 Technical data

---

### 4.1 Electrical safety

Requirements	DIN EN 61010-1 The device must be equipped with an electrical circuit that meets the requirements for "Limited-energy circuits".
--------------	---

### 4.2 Electrical data

Voltage supply	DC 4.5 to 5.5 V or DC 18 to 30 V SELV, PELV, Class 2
Current consumption	≤ 100 mA
Power consumption	≤ 3 W
Protection rating	DIN EN 61140, Class III (protective low voltage)
Electrical connection	
Connection elements	
Device	M12 plug connector, grounding pin M2.5
Connecting cable	M12 plug connector
Grounding cable	Ring cable lug M2.5
M12 plug connector	IEC 61076-2-101
Version	5-pole, shielded
Protection type	IP67
Connecting cable	
Conductor cross section	≥ AWG 28
Version	5-core, copper, shielded
Temperature resistance	≥ 80 °C
For UL application	
Approved cables <sup>a</sup>	CYJV2/8, CYJV/7, PVVA2/8, PVVA/7
Grounding cable	
Conductor cross section	1.5 mm <sup>2</sup>
Version	1-core, copper
Temperature resistance	≥ 80 °C

<sup>a</sup> The cables must be suitable for the voltage, current and temperature used.

## 4.3 Inputs

### 4.3.1 Measurands

#### Flow

Flow <sub>max</sub> DN 15 (Low-flow calibration) DN 15 DN 20 DN 25 DN 32	60 l/min 80 l/min 210 l/min 320 l/min 520 l/min
Accuracy <sup>a</sup> Reproducibility Temperature drift Response time t <sub>90</sub>	≤ ±1.0 % of the measured value ±0.03% of flow <sub>max</sub> ≤ ±0.5 % of measured value ±0.03% of flow <sub>max</sub> ≤ ±0.05 % of measured value per 10 K temperature change (at -20 to +80 °C) ≤ 2 s
Reference conditions Measurement medium Medium temperature Ambient temperature Medium pressure Measuring tube	Water 23 °C (73 °F) ±5 K 23 °C (73 °F) ±5 K 1 to 4 bar Horizontal installation, compliance with the required inlet and outlet sections
X = Flow (%) based on flow <sub>max</sub> Y = Deviation (%) from measured value	<p>The graph plots Deviation (%) on the Y-axis (0 to 5) against Flow (%) on the X-axis (0 to 100). The curve shows a sharp initial drop from ~4% deviation at 0% flow to ~1.5% at 10% flow, then continues to level off towards 1% deviation as flow increases to 100%.</p>

<sup>a</sup> Under reference conditions.

#### Temperature

Measuring range	-40 to +125 °C
Accuracy	±2 K

## 4 Technical data

---

### Pressure (optional)

Measuring range DN 15, DN 20, DN 25 DN 32	-1 to +16 bar relative pressure -1 to +10 bar relative pressure
Accuracy At 20 °C <sup>a</sup> At -20 to +100 °C <sup>c</sup>	±0.4% MSP <sup>b</sup> ±1% MSP

<sup>a</sup> Includes: linearity, hysteresis, repeatability, deviation of measuring range initial value, and measuring range end value.

<sup>b</sup> MSP = measuring span.

<sup>c</sup> Includes: linearity, hysteresis, repeatability, deviation of measuring range initial value, and measuring range end value, thermal effect on measuring range start and measuring span.

## 4.4 Interfaces

### 4.4.1 Bluetooth

Function	Transfer of configuration data and device information, display of process values
Communication	Via end device with JUMO smartCONNECT app
Authentication	Via Bluetooth® radio module and NFC tag
Connection status (configurable) Permanently Temporarily	Active Restricted (via NFC)
Range	10 m under reference conditions
Radio frequency Bluetooth® radio module NFC tag	2.4 GHz 13.56 MHz
Max. transmission power Bluetooth® radio module NFC tag	0 dBm –
JUMO smartCONNECT app System requirements iOS device Android device	iPhone 7 or later (recommended) with iOS 13 Android 8.0 or later

### 4.4.2 RS485

Function	Transfer of process data, configuration data, and device information
Communication	Via end device with JUMO DSM software, Modbus master, PLC
Data transmission	Serial
Transmission protocol	JUMO digiLine Modbus RTU
Data format	8 - 1 - no parity 8 - 1 - odd parity 8 - 1 - even parity 8 - 2 - no parity
Data transmission rate	9600 baud 19200 baud 38400 baud
Min. response time	0 to 500 ms
Device address	1 to 247

### 4.5 Display

Type	TFT display
Size	
Display range	35.04 × 28.03 mm
Screen size (diagonal)	1.77"
Resolution	128 × 160 RGB
Brightness	15 levels active + 1 level inactive (configurable)
Rotation	0°, 90°, 180°, 270° (configurable)

## 4 Technical data

### 4.6 Environmental influences

The product is UL-approved. The approval stipulates that the product may be used indoors only.

Admissible ambient temperature	DIN 60068-2-1, DIN 60068-2-2
At medium temperature $\leq 50$ °C	-20 to +50 °C
At medium temperature $\leq 80$ °C <sup>a</sup>	-20 to +60 °C
At medium temperature $> 80$ °C <sup>a</sup>	-20 to +45 °C
Admissible storage temperature	-20 to +60 °C
Climatic conditions	DIN EN 60721-3-1, DIN EN 60721-3-3, DIN EN 60068-2-78
Climate class	3K6
Air temperature	-20 to +55 °C
Relative humidity	$\leq 100$ % – Condensation on device outer shell
Protection type	DIN EN 60529, EN 50102 IP65, IP67
Electromagnetic compatibility (EMC)	DIN EN 61326-2-3:2022
Interference emission	Class B <sup>b</sup>
Interference immunity	Industrial requirements
Oscillation	DIN EN 60068-2-6
Amplitude	0,35 mm at 10 to 2000 Hz
Acceleration	5 g at 10 to 2000 Hz
Shock	DIN EN 60068-2-27
Peak acceleration	20 g
Shock duration	11 ms
Pressure Equipment Directive	2014/68/EU
Group 1 fluids - DN $\leq 25$	Sound engineering practice acc. to Art. 4, para. 3 i. c. w. Art. 4 para. 1c.i
Group 2 fluids - DN $\leq 32$	Sound engineering practice acc. to Art. 4, para. 3 i. c. w. Art. 4 para. 1c.i
Group 1 fluids	Sound engineering practice acc. to Art. 4, para. 3 i. c. w. Art. 4 para. 1c.ii

<sup>a</sup> Without UL approval.

<sup>b</sup> The product is suitable for industrial use as well as for households and small businesses.

### 4.7 Mechanical features

#### 4.7.1 Device

Weight <sup>a</sup>	
Without screw connection	$\geq 215$ to $\leq 385$ g

<sup>a</sup> Depends on version and DN.

## 4.7.2 Materials

Housing	PA66-GF25
Display cover	PMMA
Components in contact with the medium Measuring tube Transducer Seals Process connection, transducer	PPSU PEEK EPDM or FKM (optionally)
Approvals Components in contact with the medium	Drinking water certified materials (when using EPDM seals)

## 4.7.3 Nominal pressure

Nominal pressure level DN 15, DN 20, DN 25 DN 32	PN 16 PN 10
--	----------------

## 4.7.4 Pressure loss diagram

Created under reference conditions ⇒ Page 13.

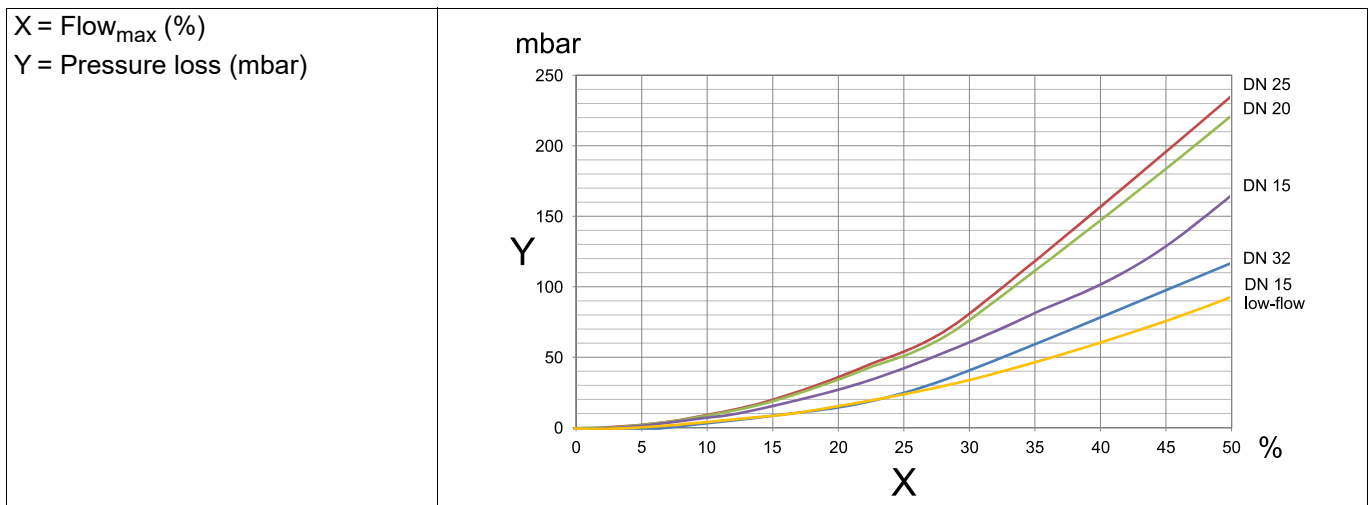

## 4 Technical data

### 4.8 Measurement media

Medium type	Conductive or non-conductive liquids
Viscosity	$\leq 100$ mPas
Foreign matter content	
Solids	$\leq 5$ % vol $\leq 1$ % vol
Medium temperature	
Temperature range	-20 to +95 °C
Within the accuracy	-20 to +50 °C
Within the accuracy <sup>a</sup>	-20 to +80 °C
Outside of the accuracy <sup>a, b</sup>	> 80 to 95 °C

<sup>a</sup> Without UL approval.

<sup>b</sup> Return to the accuracy after cooling down.

### 4.9 Dimensions

#### 4.9.1 Device

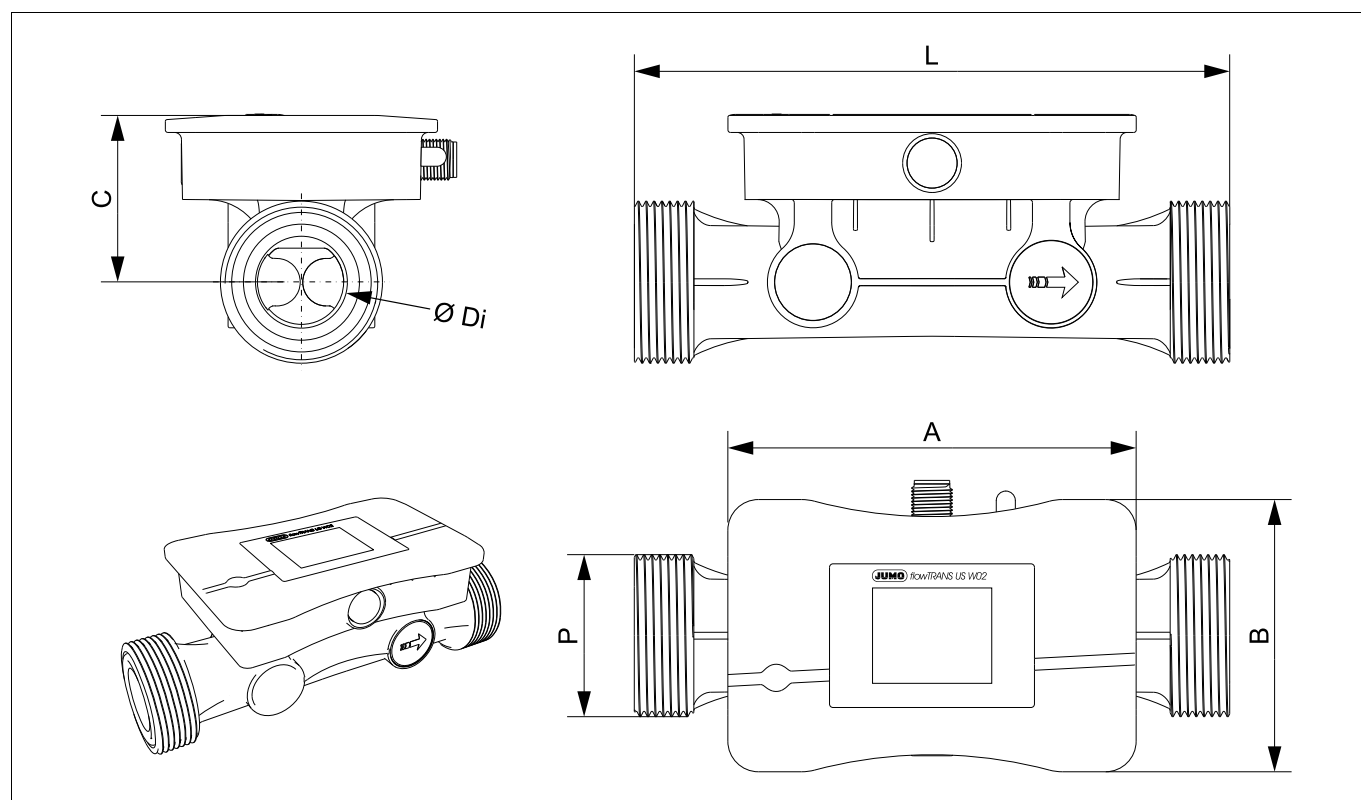

Nominal width	Ø Di [mm]	P	A [mm]	B [mm]	C [mm]	L [mm]
DN 15	16.5	G 1	120	80	43.5	155
DN 20	21.5	G 1 1/4			46	165
DN 25	27	G 1 1/2			49	175
DN 32	34	G 2			52.5	185

## 4.9.2 Accessories

### Mounting sets

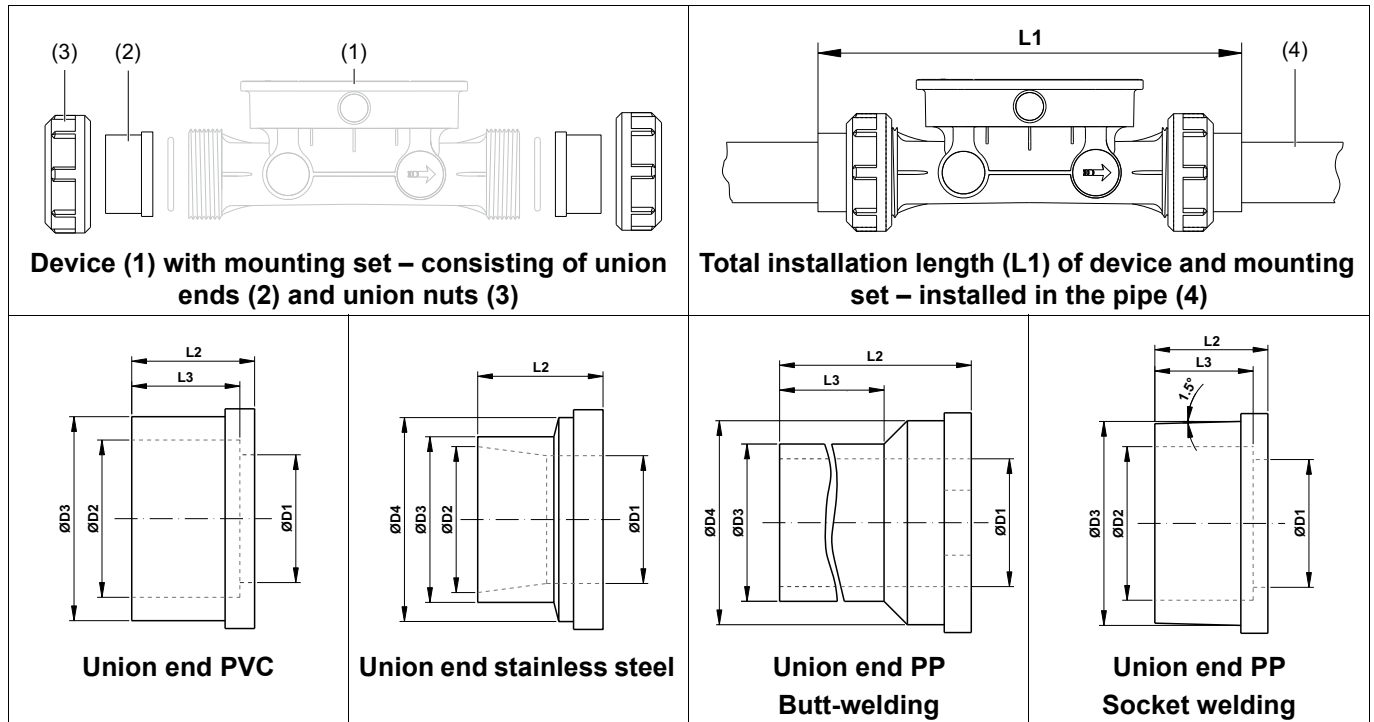

Nominal width	ØD1 [mm]	ØD2 [mm]	ØD3 [mm]	ØD4 [mm]	L1 [mm]	L2 [mm]	L3 [mm]
<b>Union end PVC</b>							
DN 15 to DN 10	10.5	16	23.5	27.5	203	24	16
DN 15	15	20	27.5	-	198	19	16
DN 20	22	25	36	-	209	22	19
DN 25	26	32	41.5	-	225	25	22
DN 32	33	40	53	-	243	29	26
<b>Union end stainless steel</b>							
DN 15 to DN 10	10.5	16	23.5	27.5	203	24	16
DN 15	15	17.3	21.3	27.5	203	21.5	-
DN 20	22	22.9	26.9	36	210	22.5	-
DN 25	26	29.7	33.7	41.5	226	25.5	-
DN 32	33	38.4	42.4	53	236	25.5	-
<b>Union end PP butt-welding</b>							
DN 15	15/16.2	-	20	27.5	266	53	37.75
DN 20	19.8	-	25	36	277.8	56.4	38.6
DN 25	26	-	32	41.5	293	59	41.25
DN 32	32.6	-	40	53	310.6	62.8	41.8
<b>Union end PP socket-welding</b>							
DN 15	17	19.35	27.5	-	198	19	16
DN 20	21	24.3	36	-	207	21	18
DN 25	26	31.25	41.5	-	221	23	20
DN 32	33	39.2	53	-	235	25	22

# 5 Installation

## 5.1 Preparing for installation

### 5.1.1 Installation site

Requirements:

- The device is protected from electromechanical interference.
- The device is protected from UV radiation.
- The device is protected from the weather in outdoor applications.

### 5.1.2 Inlet and outlet sections

To ensure measurement accuracy, longer inlet and outlet distances may be required depending on the application.

DN = Nominal pipe width

→ = Flow direction

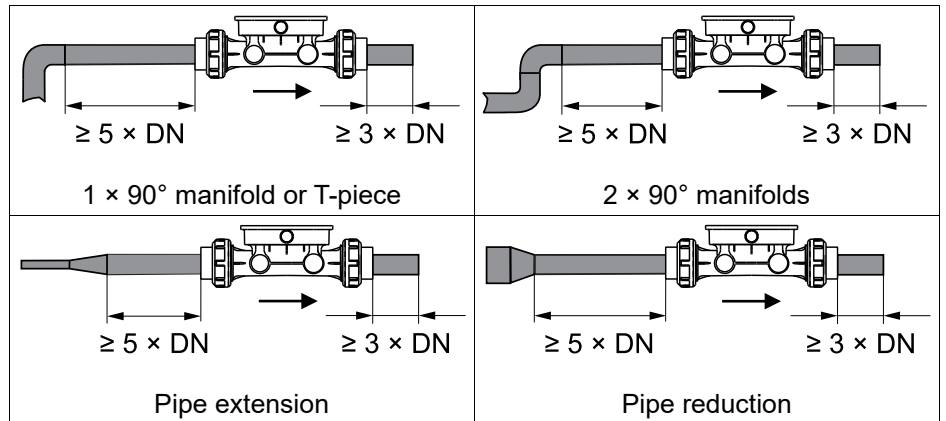

### 5.1.3 Installation position

→ = Flow direction

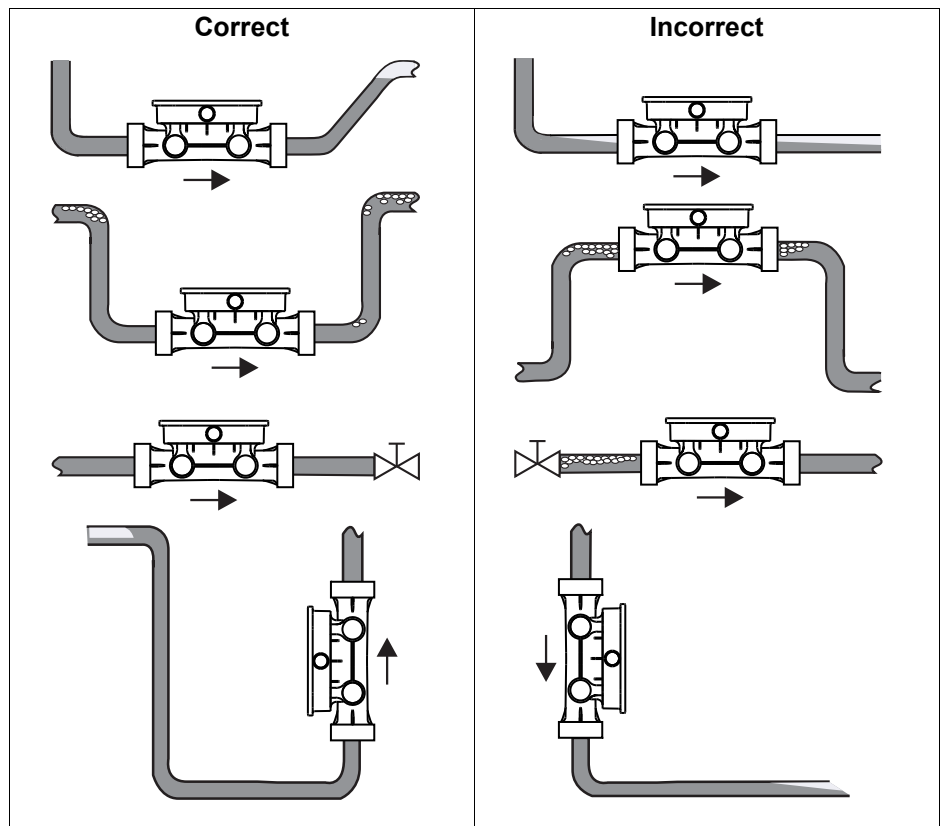

## 5.1.4 Avoid mechanical strain

Requirements:

- The center axes of both pipe ends are aligned (A-B) before mounting in the pipeline (1).
- The pipe ends are aligned parallel and at an angle to each other (C).
- The insertion length (L) of the device is observed.

Mounting sets, ⇨Page 58.

Dimensions, ⇨Page 19.

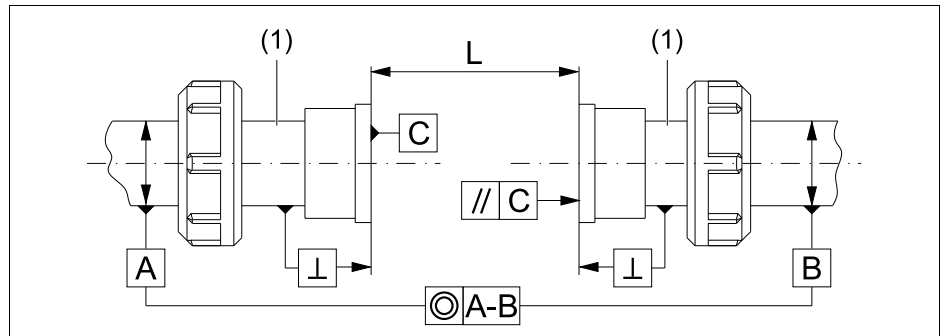

Nominal width	Insertion length L [mm]
DN 15	155
DN 20	165
DN 25	175
DN 32	185

## 5.1.5 Flow direction

The positive flow direction (→) is shown on the transducer covers on both sides of the device and must be observed during installation, in accordance with the application in question.

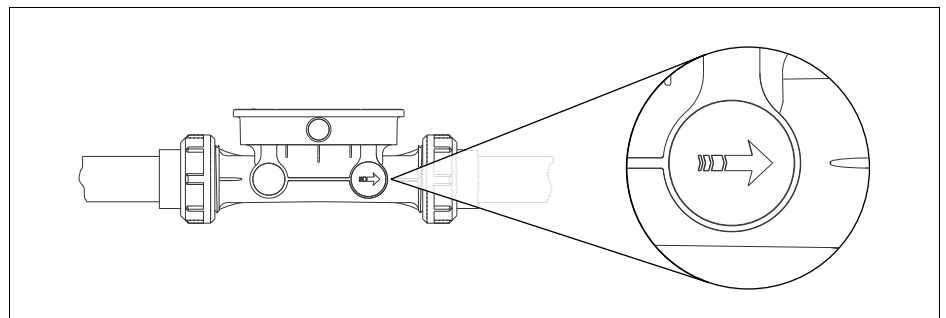

## 5.1.6 Alignment of the housing for electronic components

**CAUTION!** Protect the electronics housing from heating up by hot media. Install the electronics housing oriented 90° to the side at medium temperatures > 60 °C (140 °F).

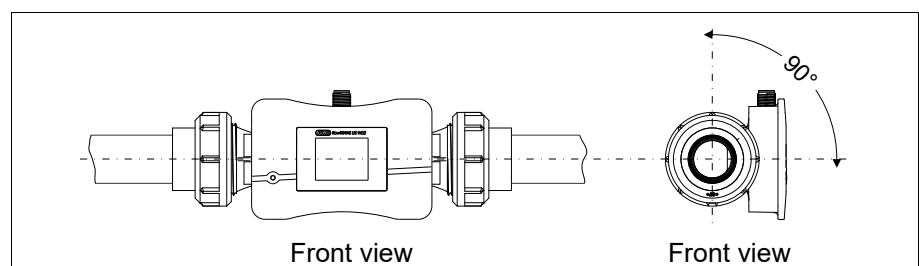

# 5 Installation

## 5.2 Installing the device

Describes the installation in the pipe with accessory mounting kits, ⇨Page 19.

Material	2 O-rings (process connection seals)
----------	--------------------------------------

Requirements:

- The system has been de-energized and secured against being switched on again.
- The medium circulation of the plant is stopped.
- The pipe is drained and rinsed.
- Suitable protective equipment has been set up.
- The pipe is prepared for installation with the mounting kits.

Procedure:

1. Insert the O-rings (1) into the sealing ring grooves in the two process connections.

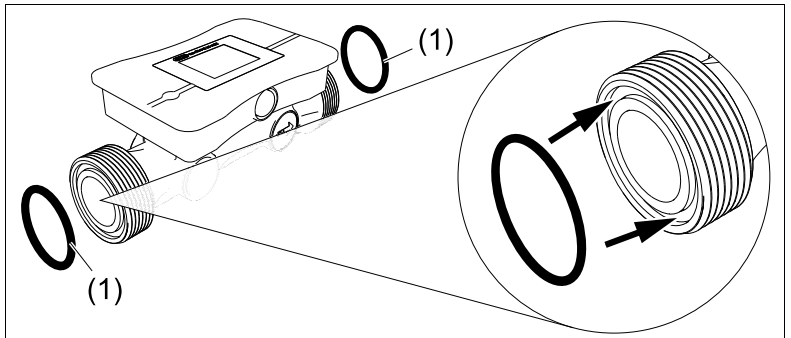

2. Install the device between the two union ends (3) of the mounting set.

Ensure that the O-rings (1) between the process connections (2) and union ends are correctly positioned.

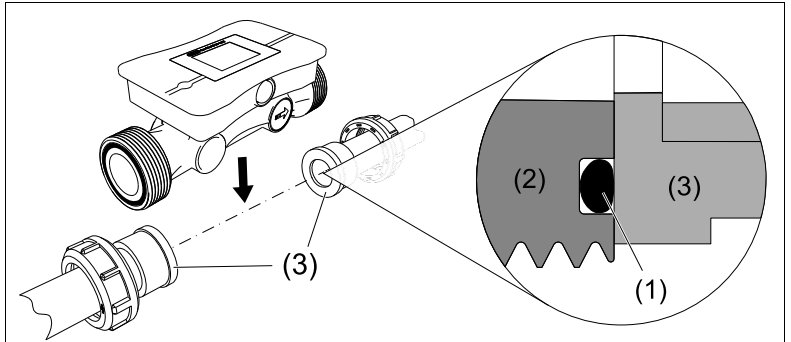

3. Manually screw union nuts (4) on both ends of the pipe to the process connections on the device.

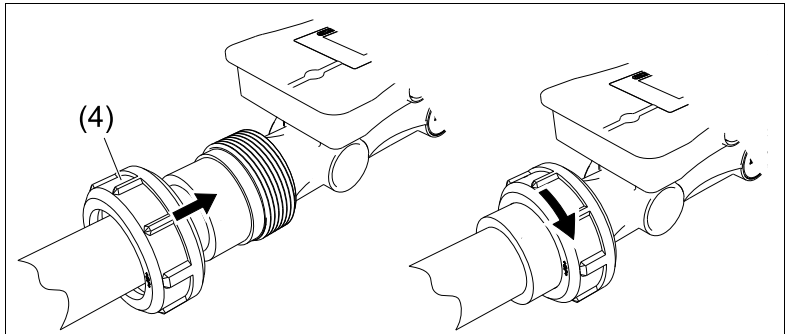

4. Switch on the plant, fill the pipe and check the tightness of the process connections under operating conditions.

The device is now installed in the pipe.

## 6.1 Connection elements

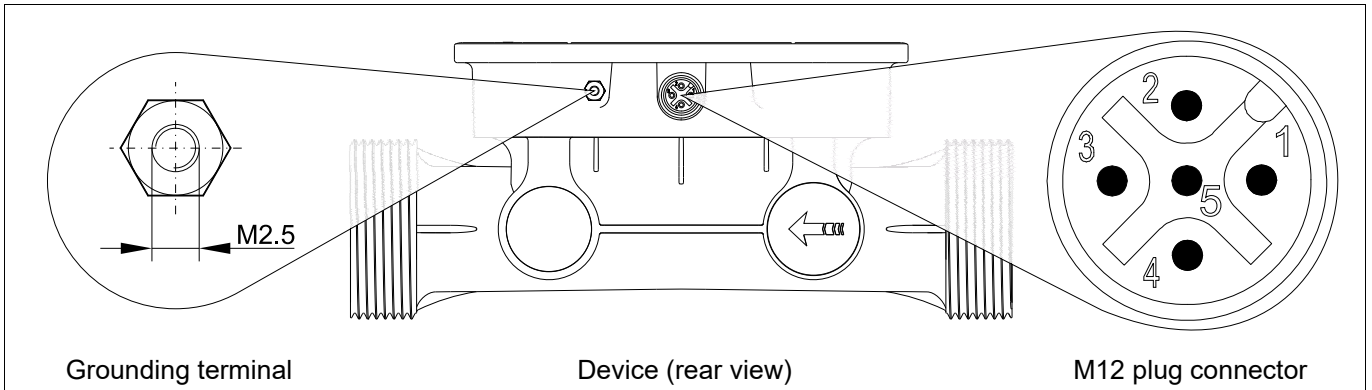

### 6.1.1 Terminal assignment

#### M12 plug connection

Designation	Description	Assignment		
RS485	DC 5 V	1 BN (Brown)		
	DC 24 V	2 WH (White)		
	GND	3 BU (Blue)		
	RS485 (RxD/TxD-)	4 BK (Black)		
	RS485 (RxD/TxD+)	5 GY (Grey)		
			Device	Connecting cable

# 6 Electrical connection

## 6.2 Connecting the device

Aids	Torque wrench with socket insert, SW5
Materials	Connecting cable for plug connector M12
	Grounding cable with ring cable lug M2,5
	Hexagon nut DIN EN ISO 4032 M2,5

### Requirements:

- The system has been de-energized and secured against being switched on again.
- The connections for grounding, voltage supply and signal processing are professionally prepared.
- The connection cable and the grounding cable are temperature resistant according to the process.
- The connection cable is installed at a minimum distance of 30 cm from high-voltage or high-frequency cables.

### Procedure:

1. Remove the protective cap (1) from the grounding terminal (2).

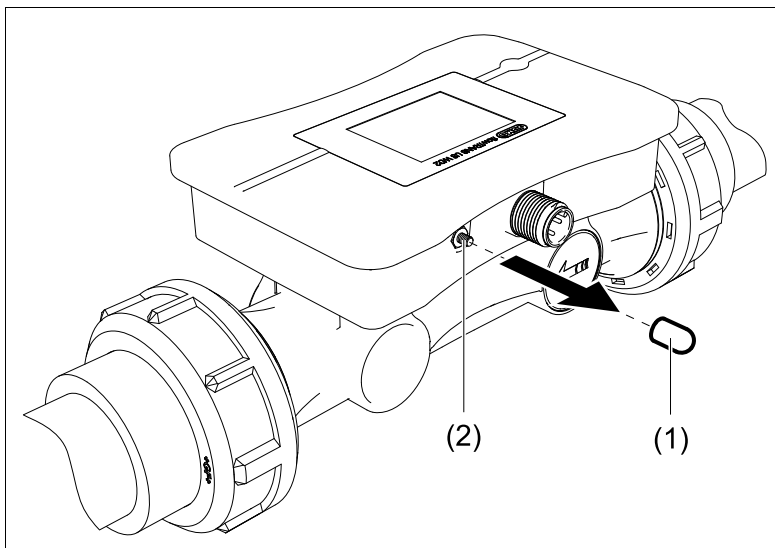

2. Plug the ring cable lug of the grounding cable (3) onto the grounding terminal and secure with the hexagon nut (4).

Tightening torque: 0.4 Nm.

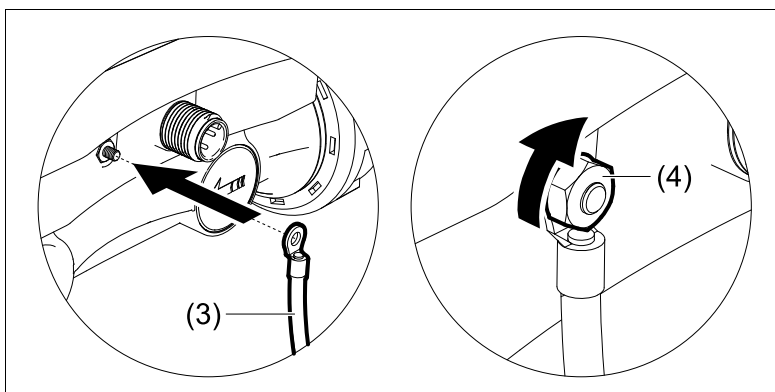

## 6 Electrical connection

3. Insert the connecting cable (5) into the M12 plug connection (6).

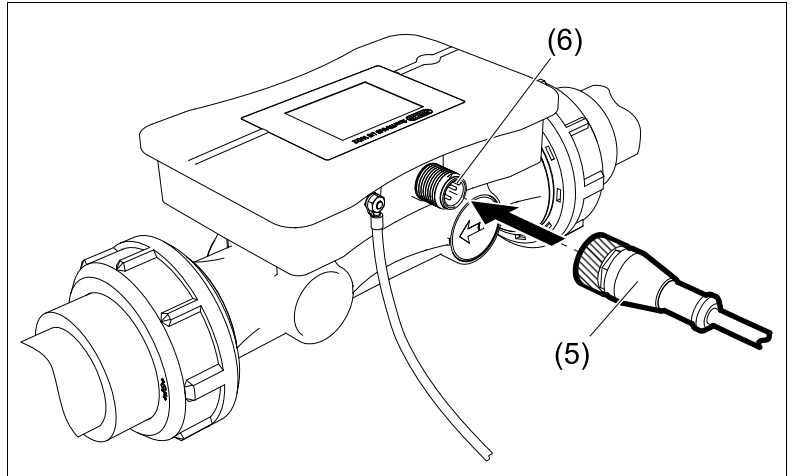

4. Screw the union nut (7) of the connecting cable onto the M12 plug connection.  
Tightening torque: 0.4 Nm.

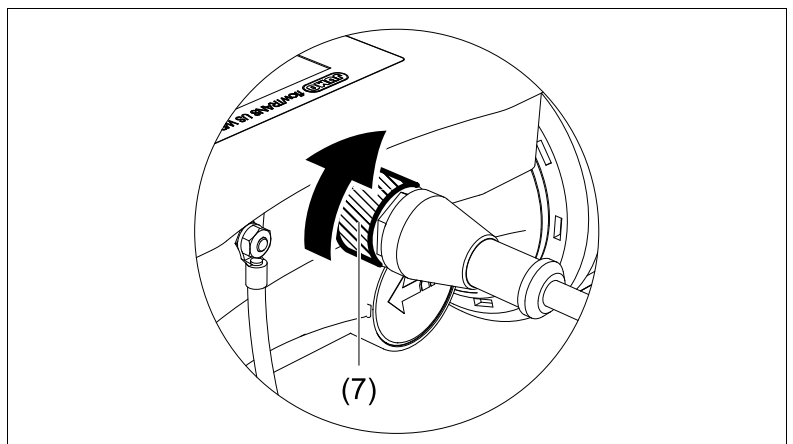

5. Connect the connecting cable to the device that is processing the signals and to the voltage supply.
6. Lay the connecting cable and the grounding cable so that they are protected from mechanical load.  
The device is ready for operation as soon as the voltage supply is established,  
⇒ "Startup display ", Page 26.

# 7 Operation

## 7.1 Display elements

### 7.1.1 Startup display

The startup display appears on the display as soon as the voltage supply to the device is established. The startup display switches to the process display after approximately five seconds.

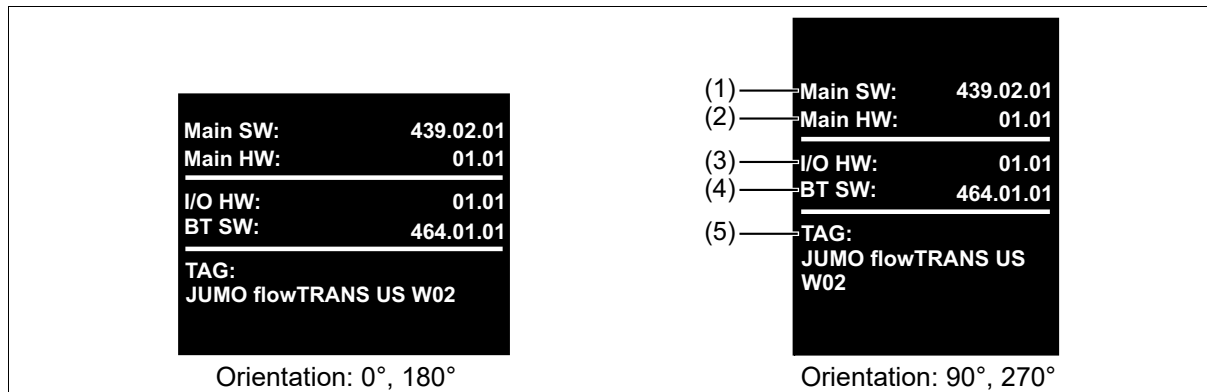

Pos.	Designation	Description
1	<b>Startup display</b>	Shows the device software version.
2, 3		Shows the device hardware version.
4		Shows the Bluetooth module software version.
5		Shows the device TAG (application-spec. marking).

### 7.1.2 Process display

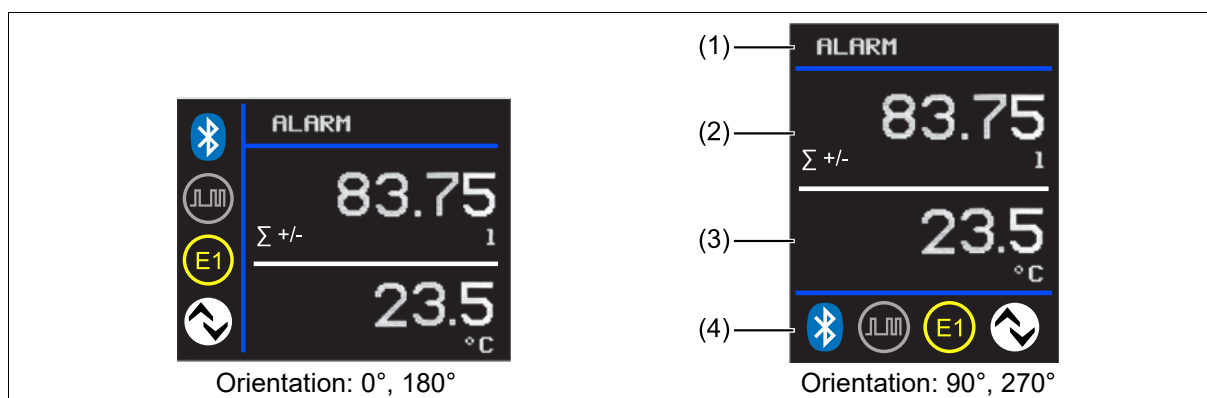

Pos.	Designation	Description
1	<b>Status bar</b>	Shows information about the device status.
2, 3	<b>Process value display 1, Process value display 2</b>	Show the following values and messages: <ul style="list-style-type: none"> <li>Both configured process values (actual values)</li> <li>The process value system units</li> <li>The totalizer for the totalizer function</li> <li>The fill volume or residual volume for the batch function</li> <li>Error messages, ⇒ "Troubleshooting ", Page 54</li> </ul>
4	<b>Toolbar</b>	Shows: <ul style="list-style-type: none"> <li>The configuration and status of the interface connections</li> </ul>

## Status bar

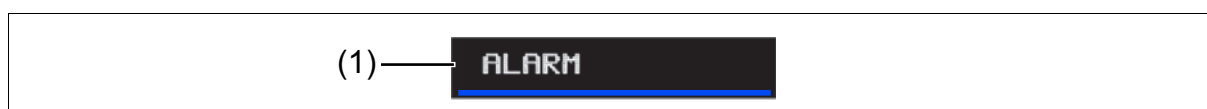

Pos.	Symbol, display	Description
1	ALARM	Shows a device error or a warning.
	BATCH	Shows an active batch operation.
	SIM	Shows an input that is in simulation mode.

## Process value display 1, process value display 2

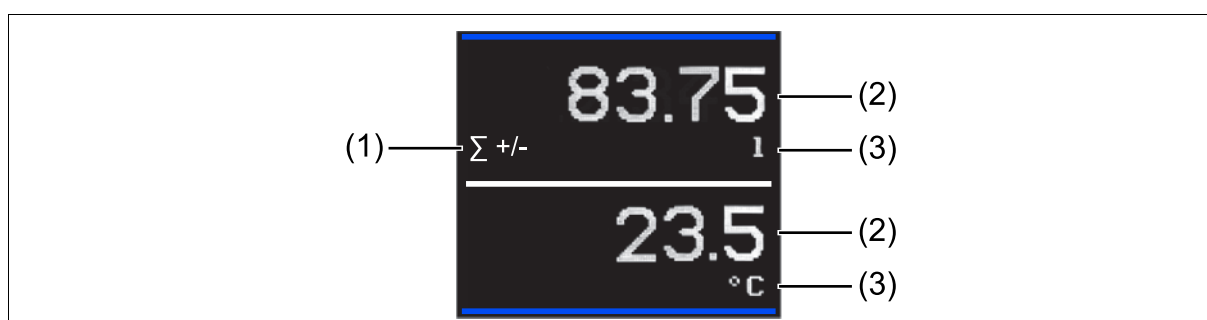

## Totalizer, totalizer transmission

Only appears when the process value display is configured accordingly.

Pos.	Symbol, display	Description
1	Σ -	Shows negative count mode of the totalizer.
	Σ +	Shows positive count mode of the totalizer.
	Σ +/-	Shows balanced count mode of the totalizer.

## Process value (5-digit)

If the process value exceeds the 5-digit display range, the number of decimal places for the process value is reduced.

Pos.	Symbol, display	Description
2	12345	Shows the positive process value.
	-12345	Shows the negative process value.

# 7 Operation





## System unit

Pos.	Symbol, display	Description
3	l/s, m <sup>3</sup> /h, ft <sup>3</sup> /min, l/min, ft <sup>3</sup> /h, usgal/min, impgal/min, l/h, cm <sup>3</sup> /s, usgal/h, impgal/h, °C, °F, mbar, bar, psi, m/s, %, l, usgal, impgal, m <sup>3</sup> , ft <sup>3</sup>	Shows the configured system unit of the process value.

## Toolbar



## Interface connections

Pos.	Symbol, display	Description
1		Interface connection: Bluetooth® Status: Inactive
		Interface connection: Bluetooth® Flashing status: Wait for connection to establish. Permanent status: Active
2		Interface connection: RS485/JUMO digiLine Status: Inactive
		Interface connection: RS485/JUMO digiLine Status: Active

## 7.2 Interfaces

### 7.2.1 Bluetooth

The JUMO smartCONNECT app allows the device to be configured and its parameters to be set using an end device. Configuration data and device information are transmitted via Bluetooth. The Bluetooth radio module of the device is permanently active during initial startup.

The app is available for free download from the [manufacturer's websites](#) or alternatively using the QR code:

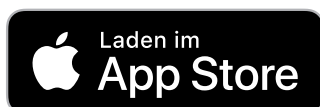

#### Bluetooth® mode

**Active:** The Bluetooth® radio module is permanently active. The device is detected by the smartCONNECT app as soon as it is within range of the Bluetooth® radio module.

**Restricted (via NFC):** The Bluetooth® radio module is inactive and can be temporarily activated via an NFC tag in the device. To establish a connection between the NFC tag and the end device, this device must be NFC-capable and held close to the device display.

**Inactive:** The Bluetooth® radio module can be disabled and enabled via Modbus RTU.

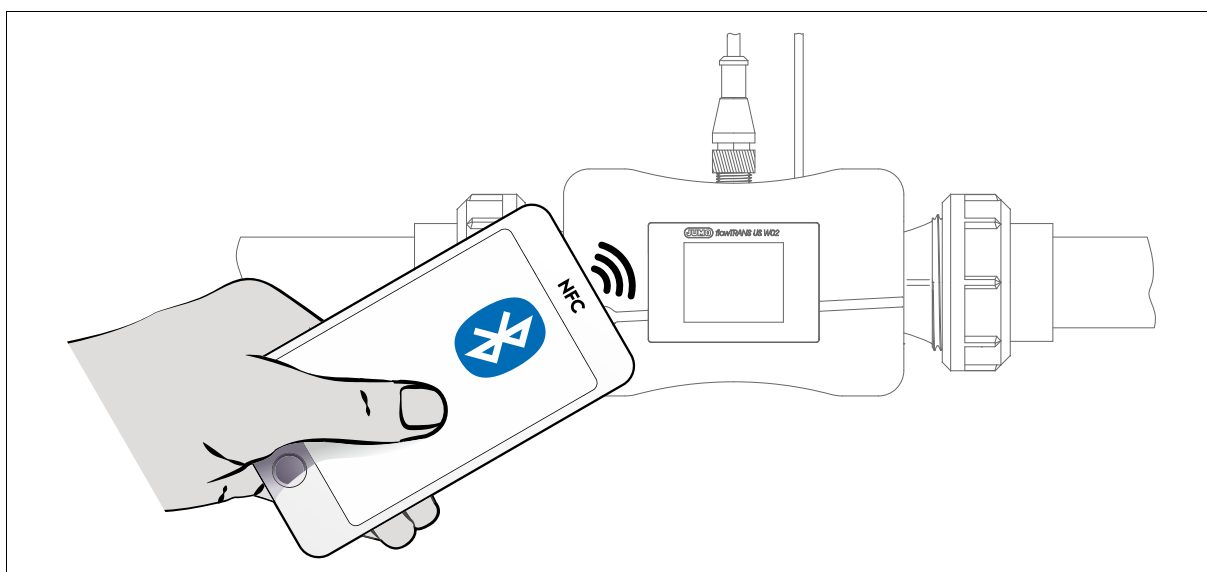

### 7.2.2 JUMO digiLine

JUMO digiLine is a bus-compatible connection system for digital sensors. The connection system enables sensor networks to be established where multiple sensors are connected to one another in a star shape or tree structure.

Multiple sensors simultaneously transfer their measurement data to the next JUMO digiLine master with Plug and Play support or in Modbus operation.

## 8 Configuration via Bluetooth®

The parameter lists are based on the JUMO smartCONNECT app operating menu. The table headings locate the respective parameters in the app operating menu..

The default settings are shown in **bold** in the following tables.

### Sensor > display

Parameter	Value	Description
Language	<b>German</b> , English, French, Spanish	National language for the device texts of the process display.
Process value 1, process value 2	No signal, <b>flow</b> , <b>temperature</b> , pressure, sound velocity, signal strength, fill volume, residual volume, totalizer 1 volume, totalizer 1 volume transmission, totalizer 2 volume, totalizer 2 volume transmission	Parameter output values (can be configured independently of one another).
Brightness	0 to 15 ( <b>8</b> )	Brightness of the process display backlight.
Rotation	<b>0°</b> , 90°, 180°, 270°	Process display alignment.

### Sensor

Parameter	Value	Description
TAG number	<b>JUMO flowTRANS US W02</b>	TAG designation (text entry with max. 32 characters possible).
Description		Description of the measuring point which can be edited with the JUMO DSM software.
Sensor origin		Displays the last used device (read-only).
Bluetooth® mode	Restricted (via NFC), <b>active</b>	Status of the Bluetooth® connection, ⇒ Seite 29.
Default settings	<b>Inactive</b> , reset	Resets the device to default settings.

### Interface

Parameter	Value	Description
Device address	<b>1</b> to 247	Bus user identification for the JUMO digiLine electronic components.
Baud rate	9600 baud/s, <b>19200 baud/s</b> , 38400 baud/s	Transmission speed (symbol rate) of the RS485 interface.
Data format	8 - 1 - no parity, 8 - 1 - odd parity, <b>8 - 1 - even parity</b> , 8 - 2 - no parity	Output format of the process data.
Min. response time	0 to 500 ( <b>20</b> )	Minimum time from receipt of a query to sending of the response. Response speed of the JUMO digiLine electronic components adjusts to match to slower bus users.

## 8 Configuration via Bluetooth®

Parameter	Value	Description
Floating point	<b>Standard</b> , LSB first, MSB first	Selectable transmission format for float values (floating-point numbers).

### System units

Parameter	Value	Description
Flow	l/s, <b>l/min</b> , l/h, cm <sup>3</sup> /s, m <sup>3</sup> /h, ft <sup>3</sup> /min, ft <sup>3</sup> /h, usgal/min, usgal/h, imp.gal/min, imp.gal/h	System unit for these parameters.
Totalizer	cm <sup>3</sup> , l, m <sup>3</sup> , ft <sup>3</sup> , usgal, imp.gal	
Temperature	°C, °F	Unit for this parameter in the process value display. The output signal is always output in °C regardless of this setting.
Pressure <sup>a</sup>	<b>bar</b> , mbar, psi	System unit for this parameter.

<sup>a</sup> Optional extra

### Measurands > flow

Parameter	Value	Description
Filter time constant	Input range: 0.000 to 25.00 ( <b>0.450</b> )	Optimization of measured value updating. The higher the filter time constant value, the slower the change in measured value at the output. Response time $t_{90}$ with default setting: $\leq 2$ s.
Low flow limit value	Input range: 0.000 to 10.00 ( <b>0.050</b> )	Input value in % of flow <sub>max</sub> of nominal width (DN) of the device. No process value is output below the limit value.
Low flow hysteresis	Input range: 0.000 to 50.00 ( <b>10.00</b> )	Input value in % of the low flow. Sets hysteresis of low flow.
Inversion	On, <b>Off</b>	Inverts the flow signal, e.g. if the device has been installed in negative flow direction.
Characteristic line	<b>Standard</b> , user-defined 1 to 9	Standard: Water User-defined 1 to 9: Not defined

## 8 Configuration via Bluetooth®

### Measurands > flow > fine adjustment

Parameter	Value	Description
Function	On, <b>Off</b>	Parameter function
ACTUAL start value	Input range: -99999 to 99999 ( <b>0.000</b> )	Input value for fine adjustment. Alternatively: parameter <b>adoption of ACTUAL start value</b>
ACTUAL end value	Input range: -99999 to 99999 ( <b>100.0</b> )	Input value for fine adjustment. Alternatively: parameter <b>adoption of ACTUAL end value</b>
TARGET start value	Input range: -99999 to 99999 ( <b>0.000</b> )	Input value for fine adjustment.
TARGET end value	Input range: -99999 to 99999 ( <b>100.0</b> )	
Adoption of ACTUAL start value	<b>Inactive</b> , adopt ACTUAL start value	Travel to ACTUAL start value and use <b>adopt ACTUAL start value</b> to adopt the measured flow value. Alternatively: parameter <b>ACTUAL start value</b>
Adoption of ACTUAL end value	<b>Inactive</b> , adopt ACTUAL end value	Travel to <b>ACTUAL</b> end value and use <b>adopt ACTUAL end value</b> to adopt the measured flow value. Alternatively: Parameter <b>ACTUAL end value</b>

### Measurands > temperature

Parameter	Value	Description
Filter time constant	Input range: 0.000 to 25.00 ( <b>1.000</b> )	Optimization of measured value updating. The higher the filter time constant value, the slower the change in measured value at the output.
Offset	Input range: -10.00 to 10.00 ( <b>0.000</b> )	Offset correction for zero point adjustment.

## 8 Configuration via Bluetooth®

### Measurands > pressure

Parameter	Value	Description
Filter time constant	Input range: 0.000 to 25.00 ( <b>1.000</b> )	Optimization of measured value updating. The higher the filter time constant value, the slower the change in measured value at the output.
Offset	Input range: -10000 up to 10000 ( <b>0.000</b> )	Offset correction for zero point adjustment.

### Totalizer

Parameter	Value	Description
Counting mode totalizer 1	<b>Positive</b> , negative, balanced	Integrate the flow components depending on the counting modes.
Counting mode totalizer 2	Positive, negative, <b>balanced</b>	Positive: Only positive flow components. Negative: Only negative flow components. Balanced: Positive and negative flow components.
Reset all totalizers	<b>Inactive</b> , reset	All totalizers and transmissions are reset.

### Simulation > flow

Parameter	Value	Description
Simulation	On, <b>Off</b>	Parameter function.
Value	Input range: -99999 up to 99999 ( <b>0.000</b> )	Input value for the simulation.

### Simulation > temperature

Parameter	Value	Description
Simulation	On, <b>Off</b>	Parameter function.
Value	Input range: -99999 up to 99999 ( <b>0.000</b> )	Input value for the simulation.

### Simulation > pressure

Parameter	Value	Description
Simulation	On, <b>Off</b>	Parameter function.
Value	Input range: -99999 up to 99999 ( <b>0.000</b> )	Input value for the simulation.

# 9 Modbus address tables

## 9.1 Modbus functions

### Function codes

The functions described in the following (from the Modbus standard) are available for extracting measured values, device and process data, and for writing data.

Function code		Function	Limit
Hex	Dec.		
03 or 04	3 or 4	Reading n words	Max. 125 words (250 bytes)
06	6	Writing one word	Max. 1 word (2 bytes)
10	16	Writing n words	Max. 123 words (246 bytes)

### Writing parameters

Write operations on specific r/w parameters result in them being saved in the EEPROM or flash memory. These memories have only a limited number of write cycles (approx. 100 000).

Frequent writing of these parameters can lead to a memory error. The number of write operations should be kept to a minimum.

### Float values

For floating-point values, this device functions with the IEEE 754 standard format (32-bit), but with the difference that bytes 1 and 2 are interchanged with bytes 3 and 4.

#### Float format (32-bit) according to IEEE 754 standard in standard Modbus byte order

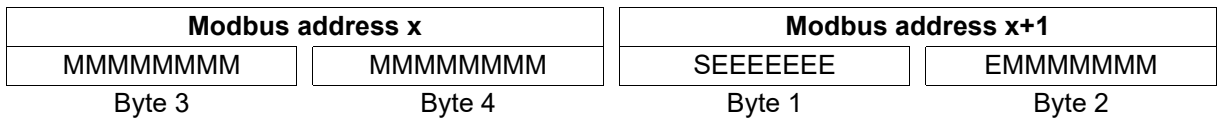

#### Float format (32-bit) according to IEEE 754 standard in Big Endian byte order

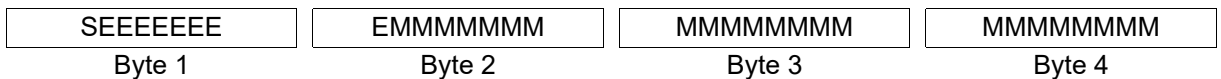

#### Float format (32-bit) according to IEEE 754 standard in Little Endian byte order

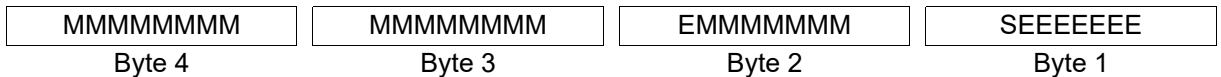

- S - Prefix sign bit
- E - Exponent (two's complement)
- M - 23-bit normalized mantissa

## 9 Modbus address tables

### 9.2 Nameplate

Modbus PDU address		Data type	Number of Modbus registers	Access <sup>a</sup>	Data	Encoding
Dec	Hex					
0	0×0000	string[10]	5	r	Device name	ASCII encoding with "ZERO" as end identifier
5	0×0005	string[12]	6	r	Software version	ASCII encoding with "ZERO" as end identifier
11	0×000B	short	1	r	Software number	–
12	0×000C	char	1	r	Sensor major version	–
13	0×000D	char	1	r	Sensor minor version	–
14	0×000E	short	1	r	Trial version	–
15	0×000F	char	1	r	Hardware major version	–
16	0×0010	char	1	r	Hardware minor version	–
17	0×0011	string[14]	7	r	VDN version	ASCII encoding with "ZERO" as end identifier
24	0×0018	short	1	r	VDN number	–
25	0×0019	short	1	r	VDN version number	–
64	0×0040	char	1	r	Major version of JUMO digiLine protocol	–
65	0×0041	char	1	r	Minor version of JUMO digiLine protocol	–
128	0×0080	char	1	r	Hardware type basis	–
129	0×0081	char	1	r	Hardware typ outputboard	–
130	0×0082	char	1	r	Hardware major version outputboard	–
131	0×0083	char	1	r	Hardware minor version outputboard	–

<sup>a</sup> r: Read access

## 9 Modbus address tables

### 9.3 Measuring point info

Modbus PDU address		Data type	Number of Modbus registers	Access <sup>a</sup>	Data	Encoding
Dec	Hex					
512	0x0200	string[60]	30	r/w	Tag number	UTF-8 encoding + "ZERO" as end identifier The number of bytes must be even (If necessary, append an additional ZERO character).
542	0x021E	string[192]	96	r/w	Description	UTF-8 encoding + "ZERO" as end identifier The number of bytes must be even (If necessary, append an additional ZERO character).
638	0x027E	string[108]	54	r/w	Sensor origin	This variable is managed automatically by the JUMO digiLine master and may not be described otherwise. UTF-8 encoding + "ZERO" as end identifier The number of bytes must be even (If necessary, append an additional ZERO character).

<sup>a</sup> r/w: Read/write access

### 9.4 Configuration of the interface

Modbus PDU address		Data type	Number of Modbus registers	Access <sup>a</sup>	Data	Encoding
Dec	Hex					
768	0x0300	char	1	r/w	Device address	–
769	0x0301	enum	1	r/w	Baud rate	0 = 9600 1 = 19200 2 = 38400
770	0x0302	enum	1	r/w	Data format	0 = 8 – 1 – no parity 1 = 8 – 1 – odd parity 2 = 8 – 1 – even parity 3 = 8 – 2 – no parity
773	0x0305	short	1	r/w	Minimum response time	–
775	0x0307	enum	1	r/w	Float value format	0 = Standard Modbus format 1 = IEEE 754 Little Endian 2 = IEEE 754 Big Endian

<sup>a</sup> r/w: Read/write access

# 9 Modbus address tables

## 9.5 Calibration data

In electronics, a calibration logbook with 10 entry data sets is stored. The addresses of the calibration logbook data are listed explicitly in the following tables.

Since all calibration logbooks have the same storage capacity, addresses can also be calculated. The address range of a calibration logbook is 0x0031 in hexadecimal or 49 in decimal notation. Using multiples of this value, jumps between different calibration logbooks can be calculated.

Example:  $0 \times 0600 + (n - 1) * 0 \times 0031$  yields the Modbus address of the parameter "Entry type" in the n-th calibration logbook.

### 9.5.1 Calibration logbook entry 1

Modbus PDU address		Data type	Number of Modbus registers	Access <sup>a</sup>	Data	Encoding
Dec	Hex					
1536	0x0600	enum	1	r	Entry type	0 = No entry 24 = 2-point fine adjustment
1537	0x0601	enum	1	r	Manual change	0 = Manual 1 = Calibration
1538	0x0602	enum	1	r	Calibration evaluation	0 = No evaluation 1 = OK 2 = Warning
1539	0x0603	long	2	r	Operating hours counter reading	Date/time stamp
1541	0x0605	short	1	r	Year	
1542	0x0606	char	1	r	Month	
1543	0x0607	char	1	r	Day	
1544	0x0608	char	1	r	Hour	
1545	0x0609	char	1	r	Minute	
1546	0x060A	char	1	r	Second	
1547	0x060B	short	1	r	Time zone	
1548	0x060C	char	1	r	Sensor change counter reading	
1549	0x060D	float[6]	12	r	Calibration values	
1561	0x0619	string[6][8]	24	r	Units	Calibration value units in the following format:  For each unit of the 6 calibration values, 8 bytes are available for the unit character string, including the ZERO character as end identifier in UTF-8 encoding. The character string may be up to 5 characters long.

<sup>a</sup> r: Read access

## 9 Modbus address tables

### 9.5.2 Calibration logbook entry 2

Modbus PDU address		Data type	Number of Modbus registers	Access <sup>a</sup>	Data	Encoding
Dec	Hex					
1585	0×0631	enum	1	r	Entry type	0 = No entry 24 = 2-point fine adjustment
1586	0×0632	enum	1	r	Manual change	0 = Manual 1 = Calibration
1587	0×0633	enum	1	r	Calibration evaluation	0 = No evaluation 1 = OK 2 = Warning
1588	0×0634	long	2	r	Operating hours counter reading	Date/time stamp
1590	0×0636	short	1	r	Year	
1591	0×0637	char	1	r	Month	
1592	0×0638	char	1	r	Day	
1593	0×0639	char	1	r	Hour	
1594	0×063A	char	1	r	Minute	
1595	0×063B	char	1	r	Second	
1596	0×063C	short	1	r	Time zone	
1597	0×063D	char	1	r	Sensor change counter reading	
1598	0×063E	float[6]	12	r	Calibration values	
1610	0×064A	string[6][8]	24	r	Units	Calibration value units in the following format:  For each unit of the 6 calibration values, 8 bytes are available for the unit character string, including the ZERO character as end identifier in UTF-8 encoding. The character string may be up to 5 characters long.

<sup>a</sup> r: Read access

## 9 Modbus address tables

### 9.5.3 Calibration logbook entry 3

Modbus PDU address		Data type	Number of Modbus registers	Access <sup>a</sup>	Data	Encoding
Dec	Hex					
1634	0×0662	enum	1	r	Entry type	0 = No entry 24 = 2-point fine adjustment
1635	0×0663	enum	1	r	Manual change	0 = Manual 1 = Calibration
1636	0×0664	enum	1	r	Calibration evaluation	0 = No evaluation 1 = OK 2 = Warning
1637	0×0665	long	2	r	Operating hours counter reading	Date/time stamp
1639	0×0667	short	1	r	Year	
1640	0×0668	char	1	r	Month	
1641	0×0669	char	1	r	Day	
1642	0×066A	char	1	r	Hour	
1643	0×066B	char	1	r	Minute	
1644	0×066C	char	1	r	Second	
1645	0×066D	short	1	r	Time zone	
1646	0×066E	char	1	r	Sensor change counter reading	
1647	0×066F	float[6]	12	r	Calibration values	
1659	0×067B	string[6][8]	24	r	Units	Calibration value units in the following format:  For each unit of the 6 calibration values, 8 bytes are available for the unit character string, including the ZERO character as end identifier in UTF-8 encoding. The character string may be up to 5 characters long.

<sup>a</sup> r: Read access

## 9 Modbus address tables

### 9.5.4 Calibration logbook entry 4

Modbus PDU address		Data type	Number of Modbus registers	Access <sup>a</sup>	Data	Encoding
Dec	Hex					
1683	0×0693	enum	1	r	Entry type	0 = No entry 24 = 2-point fine adjustment
1684	0×0694	enum	1	r	Manual change	0 = Manual 1 = Calibration
1685	0×0695	enum	1	r	Calibration evaluation	0 = No evaluation 1 = OK 2 = Warning
1686	0×0696	long	2	r	Operating hours counter reading	Date/time stamp
1688	0×0698	short	1	r	Year	
1689	0×0699	char	1	r	Month	
1690	0×069A	char	1	r	Day	
1691	0×069B	char	1	r	Hour	
1692	0×069C	char	1	r	Minute	
1693	0×069D	char	1	r	Second	
1694	0×069E	short	1	r	Time zone	
1695	0×069F	char	1	r	Sensor change counter reading	
1696	0×06A0	float[6]	12	r	Calibration values	
1708	0×06AC	string[6][8]	24	r	Units	Calibration value units in the following format:  For each unit of the 6 calibration values, 8 bytes are available for the unit character string, including the ZERO character as end identifier in UTF-8 encoding. The character string may be up to 5 characters long.

<sup>a</sup> r: Read access

## 9 Modbus address tables

### 9.5.5 Calibration logbook entry 5

Modbus PDU address		Data type	Number of Modbus registers	Access <sup>a</sup>	Data	Encoding
Dec	Hex					
1732	0×06C4	enum	1	r	Entry type	0 = No entry 24 = 2-point fine adjustment
1733	0×06C5	enum	1	r	Manual change	0 = Manual 1 = Calibration
1734	0×06C6	enum	1	r	Calibration evaluation	0 = No evaluation 1 = OK 2 = Warning
1735	0×06C7	long	2	r	Operating hours counter reading	Date/time stamp
1737	0×06C9	short	1	r	Year	
1738	0×06CA	char	1	r	Month	
1739	0×06CB	char	1	r	Day	
1740	0×06CC	char	1	r	Hour	
1741	0×06CD	char	1	r	Minute	
1742	0×06CE	char	1	r	Second	
1743	0×06CF	short	1	r	Time zone	
1744	0×06D0	char	1	r	Sensor change counter reading	
1745	0×06D1	float[6]	12	r	Calibration values	
1757	0×06DD	string[6][8]	24	r	Units	Calibration value units in the following format:  For each unit of the 6 calibration values, 8 bytes are available for the unit character string, including the ZERO character as end identifier in UTF-8 encoding. The character string may be up to 5 characters long.

<sup>a</sup> r: Read access

## 9 Modbus address tables

### 9.5.6 Calibration logbook entry 6

Modbus PDU address		Data type	Number of Modbus registers	Access <sup>a</sup>	Data	Encoding	
Dec	Hex						
1781	0x06F5	enum	1	r	Entry type	0 = No entry 24 = 2-point fine adjustment	
1782	0x06F6	enum	1	r	Manual change	0 = Manual 1 = Calibration	
1783	0x06F7	enum	1	r	Calibration evaluation	0 = No evaluation 1 = OK 2 = Warning	
1784	0x06F8	long	2	r	Operating hours counter reading	Date/time stamp	
1786	0x06FA	short	1	r	Year		
1787	0x06FB	char	1	r	Month		
1788	0x06FC	char	1	r	Day		
1789	0x06FD	char	1	r	Hour		
1790	0x06FE	char	1	r	Minute		
1791	0x06FF	char	1	r	Second		
1792	0x0700	short	1	r	Time zone		
1793	0x0701	char	1	r	Sensor change counter reading		
1794	0x0702	float[6]	12	r	Calibration values		Array elements for entry type "2-point fine adjustment": [0] = ACTUAL start value [1] = ACTUAL end value [2] = TARGET start value [3] = TARGET end value [4] = Function
1806	0x070E	string[6][8]	24	r	Units		Calibration value units in the following format:  For each unit of the 6 calibration values, 8 bytes are available for the unit character string, including the ZERO character as end identifier in UTF-8 encoding. The character string may be up to 5 characters long.

<sup>a</sup> r: Read access

## 9 Modbus address tables

### 9.5.7 Calibration logbook entry 7

Modbus PDU address		Data type	Number of Modbus registers	Access <sup>a</sup>	Data	Encoding
Dec	Hex					
1830	0×0726	enum	1	r	Entry type	0 = No entry 24 = 2-point fine adjustment
1831	0×0727	enum	1	r	Manual change	0 = Manual 1 = Calibration
1832	0×0728	enum	1	r	Calibration evaluation	0 = No evaluation 1 = OK 2 = Warning
1833	0×0729	long	2	r	Operating hours counter reading	Date/time stamp
1835	0×072B	short	1	r	Year	
1836	0×072C	char	1	r	Month	
1837	0×072D	char	1	r	Day	
1838	0×072E	char	1	r	Hour	
1839	0×072F	char	1	r	Minute	
1840	0×0730	char	1	r	Second	
1841	0×0731	short	1	r	Time zone	
1842	0×0732	char	1	r	Sensor change counter reading	
1843	0×0733	float[6]	12	r	Calibration values	
1855	0×073F	string[6][8]	24	r	Units	Calibration value units in the following format:  For each unit of the 6 calibration values, 8 bytes are available for the unit character string, including the ZERO character as end identifier in UTF-8 encoding. The character string may be up to 5 characters long.

<sup>a</sup> r: Read access

## 9 Modbus address tables

### 9.5.8 Calibration logbook entry 8

Modbus PDU address		Data type	Number of Modbus registers	Access <sup>a</sup>	Data	Encoding
Dec	Hex					
1879	0×0757	enum	1	r	Entry type	0 = No entry 24 = 2-point fine adjustment
1880	0×0758	enum	1	r	Manual change	0 = Manual 1 = Calibration
1881	0×0759	enum	1	r	Calibration evaluation	0 = No evaluation 1 = OK 2 = Warning
1882	0×075A	long	2	r	Operating hours counter reading	Date/time stamp
1884	0×075C	short	1	r	Year	
1885	0×075D	char	1	r	Month	
1886	0×075E	char	1	r	Day	
1887	0×075F	char	1	r	Hour	
1888	0×0760	char	1	r	Minute	
1889	0×0761	char	1	r	Second	
1890	0×0762	short	1	r	Time zone	
1891	0×0763	char	1	r	Sensor change counter reading	
1892	0×0764	float[6]	12	r	Calibration values	
1904	0×0770	string[6][8]	24	r	Units	Calibration value units in the following format:  For each unit of the 6 calibration values, 8 bytes are available for the unit character string, including the ZERO character as end identifier in UTF-8 encoding. The character string may be up to 5 characters long.

<sup>a</sup> r: Read access

## 9 Modbus address tables

### 9.5.9 Calibration logbook entry 9

Modbus PDU address		Data type	Number of Modbus registers	Access <sup>a</sup>	Data	Encoding
Dec	Hex					
1928	0×0788	enum	1	r	Entry type	0 = No entry 24 = 2-point fine adjustment
1929	0×0789	enum	1	r	Manual change	0 = Manual 1 = Calibration
1930	0×078A	enum	1	r	Calibration evaluation	0 = No evaluation 1 = OK 2 = Warning
1931	0×078B	long	2	r	Operating hours counter reading	Date/time stamp
1933	0×078D	short	1	r	Year	
1934	0×078E	char	1	r	Month	
1935	0×078F	char	1	r	Day	
1936	0×0790	char	1	r	Hour	
1937	0×0791	char	1	r	Minute	
1938	0×0792	char	1	r	Second	
1939	0×0793	short	1	r	Time zone	
1940	0×0794	char	1	r	Sensor change counter reading	
1941	0×0795	float[6]	12	r	Calibration values	
1953	0×07A1	string[6][8]	24	r	Units	Calibration value units in the following format:  For each unit of the 6 calibration values, 8 bytes are available for the unit character string, including the ZERO character as end identifier in UTF-8 encoding. The character string may be up to 5 characters long.

<sup>a</sup> r: Read access

## 9 Modbus address tables

### 9.5.10 Calibration logbook entry 10

Modbus PDU address		Data type	Number of Modbus registers	Access <sup>a</sup>	Data	Encoding
Dec	Hex					
1977	0×07B9	enum	1	r	Entry type	0 = No entry 24 = 2-point fine adjustment
1978	0×07BA	enum	1	r	Manual change	0 = Manual 1 = Calibration
1979	0×07BB	enum	1	r	Calibration evaluation	0 = No evaluation 1 = OK 2 = Warning
1980	0×07BC	long	2	r	Operating hours counter reading	Date/time stamp
1982	0×07BE	short	1	r	Year	
1983	0×07BF	char	1	r	Month	
1984	0×07C0	char	1	r	Day	
1985	0×07C1	char	1	r	Hour	
1986	0×07C2	char	1	r	Minute	
1987	0×07C3	char	1	r	Second	
1988	0×07C4	short	1	r	Time zone	
1989	0×07C5	char	1	r	Sensor change counter reading	
1990	0×07C6	float[6]	12	r	Calibration values	
2002	0×07D2	string[6][8]	24	r	Units	Calibration value units in the following format:  For each unit of the 6 calibration values, 8 bytes are available for the unit character string, including the ZERO character as end identifier in UTF-8 encoding. The character string may be up to 5 characters long.

<sup>a</sup> r: Read access

## 9 Modbus address tables

### 9.6 Configuration flow

Modbus PDU address		Data type	Number of Modbus registers	Access <sup>a</sup>	Data	Encoding
Dec	Hex					
20736	0×5100	enum	1	r/w	Unit for flow	0 = l/s 1 = l/min 2 = l/h 3 = cm <sup>3</sup> /s 4 = m <sup>3</sup> /h 5 = ft <sup>3</sup> /min 6 = ft <sup>3</sup> /h 7 = usgal/min 8 = usgal/h 9 = impgal/min 10 = impgal/h
20737	0×5101	enum	1	r/w	Unit for volume	0 = cm <sup>3</sup> 1 = l
20738	0×5102	enum	1	r/w	Unit for volume counter	2 = m <sup>3</sup> 3 = ft <sup>3</sup> 4 = usgal 5 = impgal
20739	0×5103	float	2	r/w	Filter time	Unit: s
20741	0×5105	float	2	r/w	Switching threshold	Unit: %
20743	0×5107	float	2	r/w	Hysteresis	
20745	0×5109	float	1	r/w	Inversion	0 = Inactive 1 = Active
20746	0×510A	float	2	r/w	Simulation value	⇒ "Unit for flow" in this table
20748	0×510C	enum	1	r/w	Medium	0 = Standard 1 = User-specific 1 2 = User-specific 2 3 = User-specific 3 4 = User-specific 4 5 = User-specific 5 6 = User-specific 6 7 = User-specific 7 8 = User-specific 8 9 = User-specific 9

<sup>a</sup> r/w: Read/write access

### 9.7 Configuration temperature

Modbus PDU address		Data type	Number of Modbus registers	Access <sup>a</sup>	Data	Encoding
Dec	Hex					
20992	0×5200	float	2	r/w	Filter time constant	Unit: s
20994	0×5202	float	2	r/w	Offset	Unit: °C
20996	0×5204	float	2	r/w	Simulation value	

<sup>a</sup> r/w: Read/write access

## 9 Modbus address tables

### 9.8 Configuration pressure

Modbus PDU address		Data type	Number of Modbus registers	Access <sup>a</sup>	Data	Encoding
Dec	Hex					
21248	0×5300	enum	1	r/w	Unit for pressure	0 = bar 1 = mbar 2 = psi
21249	0×5301	float	2	r/w	Filter time constant	Unit: s
21251	0×5303	float	2	r/w	Offset	⇒"Unit for pressure" in this table
21253	0×5305	float	2	r/w	Simulation value	

<sup>a</sup> r/w: Read/write access

### 9.9 Configuration display

Modbus PDU address		Data type	Number of Modbus registers	Access <sup>a</sup>	Data	Encoding
Dec	Hex					
23808	0×5D00	enum	1	r/w	Language	0 = German 1 = English 2 = French 3 = Spanish
23809	0×5D01	enum	1	r/w	Process value 1	0 = No signal 1 = Flow 2 = Temperature 3 = Pressure 4 = Sound velocity 5 = Signal strength 6 = Filling volume 7 = Residual volume 8 = Totalizer 1 volume 9 = Totalizer 1 volume carry 10 = Totalizer 2 volume 11 = Totalizer 2 volume carry
23810	0×5D02	enum	1	r/w	Process value 2	
23811	0×5D03	short	1	r/w	Brightness	⇒Page 15
23812	0×5D04	enum	1	r/w	Rotation	0 = 0° 1 = 90° 2 = 180° 3 = 270°
23813	0×5D05	enum	1	r/w	Unit for temperature	0 = °C 1 = °F

<sup>a</sup> r/w: Read/write access

## 9 Modbus address tables

### 9.10 Configuration reset totalizer

Modbus PDU address		Data type	Number of Modbus registers	Access <sup>a</sup>	Data	Encoding
Dec	Hex					
23040	0×5A00	enum	1	r/w	Counting mode totalizer 1	0 = Positive 1 = Negative 2 = Balanced
23072	0×5A20	enum	1	r/w	Counting mode totalizer 2	

<sup>a</sup> r/w: Read/write access

### 9.11 Configuration batch

Modbus PDU address		Data type	Number of Modbus registers	Access <sup>a</sup>	Data	Encoding
Dec	Hex					
23104	0×5A40	float	2	r/w	Volume	⇒"Unit for volume counter", Page 47
23106	0×5A42	long	2	r/w	Maximum batch time	Unit: s

<sup>a</sup> r/w: Read/write access

### 9.12 Configuration Bluetooth®

Modbus PDU address		Data type	Number of Modbus registers	Access <sup>a</sup>	Data	Encoding
Dec	Hex					
23168	0×5A80	enum	1	r/w	Bluetooth® mode	0 = Inactive 1 = Restricted (via NFC) 2 = Active

<sup>a</sup> r/w: Read/write access

### 9.13 Configuration fine adjustment

Modbus PDU address		Data type	Number of Modbus registers	Access <sup>a</sup>	Data	Encoding
Dec	Hex					
20800	0×5140	char	1	r/w	Function	0 = Inactive 1 = Active
20801	0×5141	float	2	r/w	TARGET start value	⇒"Unit for volume counter", Page 47
20803	0×5143	float	2	r/w	TARGET end value	
20805	0×5145	float	2	r/w	ACTUAL start value	
20807	0×5147	float	2	r/w	ACTUAL end value	

<sup>a</sup> r/w: Read/write access

## 9 Modbus address tables

### 9.14 Process values

#### 9.14.1 Inputs

Modbus PDU address		Data type	Number of Modbus registers	Access <sup>a</sup>	Data	Encoding
Dec	Hex					
8256	0×2040	float	2	r	Flow	⇒"Unit for volume counter", Page 47
8258	0×2042	float	2	r	Sound velocity	Unit: m/s
8260	0×2044	float	2	r	Signal strength	Unit: %
8264	0×2048	char	1	r	Alarm flow input	–
8320	0×2080	float	2	r	Temperature in °C	Unit: °C
8322	0×2082	float	2	r	Temperature in °F	Unit = °F
8324	0×2084	char	1	r	Alarm temperature input	–
8384	0×20C0	float	2	r	Pressure	⇒"Unit for pressure", Page 48
8386	0×20C2	char	1	r	Alarm pressure input	–

<sup>a</sup> r: Read access

#### 9.14.2 Simulation

Modbus PDU address		Data type	Number of Modbus registers	Access <sup>a</sup>	Data	Encoding
Dec	Hex					
8192	0×2000	enum	1	r/w	Flow simulation	0 = Inactive 1 = Active
8193	0×2001	enum	1	r/w	Temperature simulation	
8194	0×2002	enum	1	r/w	Pressure simulation	

<sup>a</sup> r/w: Read/write access

#### 9.14.3 Limit value switch

Modbus PDU address		Data type	Number of Modbus registers	Access <sup>a</sup>	Data	Encoding
Dec	Hex					
9216	0×2400	char	1	r	Limit value switch 1 output	–
9248	0×2420	char	1	r	Limit value switch 2 output	–

<sup>a</sup> r: Read access

# 9 Modbus address tables

## 9.14.4 Batch function

Modbus PDU address		Data type	Number of Modbus registers	Access <sup>a</sup>	Data	Encoding
Dec	Hex					
9856	0×2680	float	2	r	Residual volume	⇒"Unit for volume", Page 47
9858	0×2682	float	2	r	Filling volume	
9860	0×2684	enum	1	r	Status	0 = Inactive 1 = Active
9861	0×2685	char	1	r	Alarm signal	–
9862	0×2686	enum	1	r/w	Activation	0 = Idle 1 = StartStop

<sup>a</sup> r/w: Read/write access

## 9.14.5 Totalizer

Modbus PDU address		Data type	Number of Modbus registers	Access <sup>a</sup>	Data	Encoding
Dec	Hex					
9728	0×2600	enum	1	r/w	Reset all totalizers	0 = Idle 1 = ResetAllTotalizer

<sup>a</sup> r/w: Read/write access

## 9.14.6 Batch

Modbus PDU address		Data type	Number of Modbus registers	Access <sup>a</sup>	Data	Encoding
Dec	Hex					
9760	0×2620	float	2	r	Volume totalizer 1	–
9792	0×2640	float	2	r	Volume totalizer 2	–

<sup>a</sup> r: Read access

## 9.14.7 Fine adjustment

Modbus PDU address		Data type	Number of Modbus registers	Access <sup>a</sup>	Data	Encoding
Dec	Hex					
9985	0×2701	enum	1	r/w	Adoption of ACTUAL start value	0 = Idle 1 = Transfer start/end value 2 = Transfer successful 3 = Error
9986	0×2702	enum	1	r/w	Adoption of ACTUAL end value	

<sup>a</sup> r/w: Read/write access

# 9 Modbus address tables

## 9.14.8 Operation hours counter

Modbus PDU address		Data type	Number of Modbus registers	Access <sup>a</sup>	Data	Encoding
Dec	Hex					
1024	0x0400	long	2	r	Operating time counter	Unit: s

<sup>a</sup> r: Read access

## 9.14.9 Date and time for time stamp

Modbus PDU address		Data type	Number of Modbus registers	Access <sup>a</sup>	Data	Encoding
Dec	Hex					
10304	0x2840	short	1	r/w	Year	–
10305	0x2841	char	1	r/w	Month	–
10306	0x2842	char	1	r/w	Day	–
10307	0x2843	char	1	r/w	Hour	–
10308	0x2844	char	1	r/w	Minute	–
10309	0x2845	char	1	r/w	Second	–
10310	0x2846	short	1	r/w	Time zone	Offset for UTC in minutes

<sup>a</sup> r/w: Read/write access

## 9.14.10 Summary of important process values

The variables from the summarized process values are set to invalid during the boot phase to prevent unstable measured values from creating problems in masters that access these measured values. In contrast, the original variables are always represented transparently (i.e. fluctuating).

Modbus PDU address		Data type	Number of Modbus registers	Access <sup>a</sup>	Data	Encoding
Dec	Hex					
32768	0x8000	float	2	r	Flow	⇒"Unit for volume counter", Page 47
32770	0x8002	float	2	r	Sound velocity	Unit: m/s
32772	0x8004	float	2	r	Signal strength	Unit: %
32774	0x8006	short	2	r	Amplitude	–
32776	0x8008	float	2	r	Temperature in °C	Unit: °C
32778	0x800A	float	2	r	Pressure	⇒"Unit for pressure", Page 48
32780	0x800C	short	1	r	Status word	The status word is a bit field consisting of 16 status bits. The structure of the status word is shown in the following table.

<sup>a</sup> r: Read access

## 9 Modbus address tables

### Structure of the status word and meaning of its 15 status bits

Bit number	#15 (msb)	#14	#13	#12	#11	#10	#9	#8
Function	Calibration data error	Configuration data error	-	-	-	-	-	-

#7	#6	#5	#4	#3	#2	#1	#0 (lsb)
-	-	-	-	-	Pressure alarm signal	Temperature alarm signal	Flow alarm signal

## 9.15 Error messages

### Modbus error codes

Error code	Error
01	Invalid function ⇒ Page 34
02	Invalid address or too many words or bits are to be read or written.
03	Value is outside the admissible range.
08	Value is write-protected.

### Error messages for invalid values

For measured values in float format, the error number itself is displayed as a value, i.e. instead of the measured value, the error number is returned.

Error code for float values	Error
$1,0 \times 10^{37}$	Measuring range underflow
$2,0 \times 10^{37}$	Measuring range overflow
$3,0 \times 10^{37}$	No valid input value
$4,0 \times 10^{37}$	Division by zero
$5,0 \times 10^{37}$	Mathematical error
$6,0 \times 10^{37}$	Invalid compensation temperature
$7,0 \times 10^{37}$	Probe short circuit
$8,0 \times 10^{37}$	Probe break
$9,0 \times 10^{37}$	Timeout

# 10 Troubleshooting

## 10.1 Process value error

Process value errors are displayed flashing instead of the process value. With error messages in line with the NAMUR classification NE 107, process value errors are supplemented by symbols and a two-line message (alternating with the process display).

Appearance	Cause	Remedy
----	No process value signal is configured.	Configure a process value signal.
	The process value signal is faulty.	At device restart: Wait for initialization (max. 15 s). At device restart, and with the batch function activated: Execute batch.
	Internal device error	Contact the manufacturer.
+++++	The temperature sensor is faulty.	Contact the manufacturer.
<<<<<	The measuring range was undershot.	Operate the device within the device specifications.
>>>>>	The measuring range was exceeded.	Operate the device within the device specifications.

## 10.2 Error messages in line with NAMUR

Error messages in line with NAMUR classification NE 107 are displayed by symbols and a two-line message (alternating with the process display).

Symbol	Designation
	<b>Error/failure</b>

Message	Cause	Remedy
Internal error (TDC comm.)	The device is faulty.	Contact the manufacturer.
Flow invalid	Too many air bubbles in the system.	Bleed the system.
	The sensor is faulty.	Contact the manufacturer.
Temperature invalid	The measuring range has been fallen below/exceeded.	Comply with measuring range.
	The sensor is faulty.	Contact the manufacturer.
Pressure invalid	The measuring range has been fallen below/exceeded.	Comply with measuring range.
	The sensor is faulty.	Contact the manufacturer.
Configuration corrupted	The configuration data in the EEPROM are damaged.	Transfer the configuration data to the device again.
Device not calibrated	The device is not calibrated	Contact the manufacturer.
	The device is faulty.	

Symbol	Designation
	<b>Functional check</b>

Message	Cause	Remedy
Simulation active	Simulation mode is active.	Deactivate simulation mode. Alternatively: Restart device.

Symbol	Designation
	<b>Outside the specification</b>

Message	Cause	Remedy
Outside the specification	Flow: The measuring range was exceeded.	Comply with measuring range.
	Temperature: The measuring range has been fallen below/exceeded.	
	Pressure: The measuring range has been fallen below/exceeded.	
Undervoltage	The voltage supply to the device is insufficient.	Check the voltage supply to the device.
Overload at C/Q or DO	The switching outputs are overloaded.	Check the connection and load of the switching outputs.
Error analog output	The burden at the analog output is too high.	Observe the specified values for the burden of the analog output.
Max. pulse freq. exceeded	The maximum output frequency of the pulse output has been exceeded.	Check the configuration of the pulse output.
Empty conduit	The meter run is empty.	Fill the meter run or the system.
Air bubbles detected	Air bubbles have been detected in the system.	Bleed the system.

## 10.3 Error messages outside NAMUR

Error messages outside NAMUR classification NE 107 are displayed by symbols and a two-line message (alternating with the process display).

Symbol	Designation
	<b>Caution</b>

Message	Cause	Remedy
Batch error	The maximum batch time has been exceeded.	Check the filling volume of the batch and restart the process.
	A measurement error occurred during the batch.	Check the process for measurement errors and restart the process.
Batch	The batch is active.	–

# 11 Maintenance and cleaning

---

## 11.1 Cleaning device housing

The device housing can be cleaned when the device has been installed.  
Clean the device with a cloth dampened with water.

## 11.2 Decontamination

Use:

- When the medium is changed in the plant.
- Before replacing O-rings.
- Before returning the device.
- Before disposing of the device.

Requirements:

- The device is uninstalled, ⇒Page 57.
- If the medium is a hazardous substance: The information in the safety data sheet is taken into account.
- Suitable protective equipment has been set up.
- Ein geeignetes Reinigungsmittel ist einsatzbereit.
- Ein Reinigungsplatz zum Spülen und Neutralisieren aller medienberührten Teile ist vorbereitet.

Procedure:

1. **CAUTION!** Do not damage the sealing ring grooves of the process connections when removing the O-rings.  
Remove the two O-rings from the sealing ring grooves.
2. **CAUTION!** Use only cleaning agents that are compatible with the materials used to make the device.  
Thoroughly flush and neutralize all parts that come into contact with the medium using a suitable cleaning agent.
3. When disposing the device: ⇒Page 57.
4. When continuing to use the device: ⇒Page 56.

## 11.3 Replacing O-rings

Requirements:

- All components in contact with the medium are decontaminated, ⇒Page 56.

Procedure:

1. Check the O-rings previously used for damage and replace if necessary.
2. Install the device, ⇒Page 22.

## 12.1 Uninstallation

Requirements:

- The system has been de-energized and secured against being switched on again.
- The medium circulation of the plant is stopped.
- The pipe is drained and rinsed.
- Suitable protective equipment has been set up.
- A clean and dry storage location has been prepared.

Procedure:

1. Manually loosen the union nut of the connecting cable from the M12 plug connection on the device.
2. Pull the connecting cable out of the M12 plug connection and remove from the working range.
3. Release the hexagon nut from the grounding terminal.
4. Remove the grounding cable from the grounding terminal and remove from the working range.
5. Manually loosen the union nuts from the process connections on the device and slide over the ends of the pipe.
6. **CAUTION!** Make sure that the O-rings remain in the sealing ring grooves of the process connections of the device.

Carefully remove the device from the plant and put in a clean and dry place.

## 12.2 Returns

Requirements:

- Clean the device housing ⇒Page 56.
- Clean the parts that come into contact with the medium ⇒Page 56.

Procedure:

1. The [supplementary sheet for product returns](#) must first be completed correctly and signed. Then enclose it with the shipping documents and attach it to the packaging, ideally on the outside.
2. Use the original packaging or a suitably secure container for sending the device.

## 12.3 Disposal

Requirements:

- Clean the device housing ⇒Page 56.
- Clean the parts that come into contact with the medium ⇒Page 56.



- Do not dispose of the device or replaced parts in the trash after use.
- Delete programs and data stored on the device.
- Remove batteries, if any, if this can be done without damaging the device.
- Dispose of the device and the packaging material in a responsible and environmentally friendly manner.
- Observe the country-specific laws and regulations for waste treatment and disposal.

In accordance with Directive 2012/19/EU on Waste from Electrical and Electronic Equipment, manufacturers are obliged to offer the option of returning waste equipment. Request the return from the manufacturer.

# 13 Accessories

---

## Without UL approval

### Connecting cable

Designation	Part no.
JUMO M12 digiLine master connecting cable for 705001, 5-pole, A-coded, length 10 m	00665547
JUMO M12 digiLine master connecting cable for 705001, 5-pole, A-coded, length 5 m	00665539
JUMO M12 digiLine master connecting cable for 705001, 5-pole, A-coded, length 1.5 m	00665529
JUMO M12 digiLine master connecting cable, 5-pole, A-coded, length 10 m (PG 203590)	00638341
JUMO M12 digiLine master connecting cable, 5-pole, A-coded, length 5 m (PG 203590)	00638337
JUMO M12 digiLine master connecting cable, 5-pole, A-coded, length 1.5 m (PG 203590)	00638333
JUMO M12 connecting cable, 5-pole, A-coded, length 15 m	00638324
JUMO M12 connecting cable, 5-pole, A-coded, length 10 m	00638322
JUMO M12 connecting cable, 5-pole, A-coded, length 5 m	00638315
JUMO M12 connecting cable, 5-pole, A-coded, length 1.5 m	00638313
JUMO M12 connecting cable, 5-pole, A-coded, length 0.5 m	00638312
JUMO Y-distributor 5-pole (connector, socket, socket)	00638327
USB converter (Y distributor M12, USB, DC coupling)	00746250

### Electronic components

Designation	Part no.
Plug-in power supply unit 24 V / 1 A	00743955
JUMO digiLine hub	00646871
JUMO power supply unit for JUMO digiLine hub	00661597

### Software

Designation	Part no.
JUMO DSM software for JUMO digiLine sensors	00655787
JUMO DSM software for JUMO digiLine sensors incl. data management	00663703

### Suitable indicating devices/controllers

Designation	Data sheet
Modular multichannel measuring devices for liquid analysis with integrated controller and paperless recorder JUMO AQUIS touch S/P	202580/ 202581
Scalable measurement, control, and automation system JUMO mTRON T	705000/ 705001
JUMO AQUIS 500 RS indicating device/controller	202569

# 13 Accessories

---

## Accessories for JUMO AQUIS touch S/P

Designation	Part no.
Pipe-mounted kit for JUMO AQUIS touch S	00602401
Protective roof kit for JUMO AQUIS touch S	00602404
Setup program JUMO AQUIS touch S/P on mini-DVD	00594355

## Accessories for JUMO AQUIS 500 RS

Designation	Part no.
Pipe-mounted kit for JUMO AQUIS 500 RS	00398162
Weather protection canopy for JUMO AQUIS 500 RS	00398161
Setup program for JUMO AQUIS 500 on DVD	00483602
PC interface, converter RS232/TTL	00301315
PC interface, converter USB/TTL and adapter (pins/socket)	00456352

# 14 Certificates

## 14.1 China RoHS

						
产品组别 Product group: 406051	产品中有害物质的名称及含量 <b>China EEP Hazardous Substances Information</b>					
部件名称 Component Name						
	铅 (Pb)	汞 (Hg)	镉 (Cd)	六价铬 (Cr(VI))	多溴联苯 (PBB)	多溴二苯醚 (PBDE)
外壳 Housing (Gehäuse)	○	○	○	○	○	○
过程连接 Process connection (Prozessanschluss)	○	○	○	○	○	○
螺母 Nuts (Mutter)	○	○	○	○	○	○
螺栓 Screw (Schraube)	○	○	○	○	○	○
电路板 Circuit boards (Leiterplatte)	X	○	○	○	○	○
<p>本表格依据SJ/T 11364的规定编制。          This table is prepared in accordance with the provisions SJ/T 11364.</p> <p>○：表示该有害物质在该部件所有均质材料中的含量均在GB/T 26572规定的限量要求以下。          Indicate the hazardous substances in all homogeneous materials for the part are below the limit of the GB/T 26572.</p> <p>×：表示该有害物质至少在该部件的某一均质材料中的含量超出GB/T 26572规定的限量要求。          Indicate the hazardous substances in at least one homogeneous material of the part exceed the limit of the GB/T 26572.</p>						





**JUMO GmbH & Co. KG**

Street address:  
Moritz-Juchheim-Straße 1  
36039 Fulda, Germany

Delivery address:  
Mackenrodtstraße 14  
36039 Fulda, Germany

Postal address:  
36035 Fulda, Germany

Phone: +49 661 6003-0  
Fax: +49 661 6003-607  
Email: [mail@jumo.net](mailto:mail@jumo.net)  
Internet: [www.jumo.net](http://www.jumo.net)

**JUMO UKL TD**

JUMO House  
Temple Bank, Riverway  
Harlow, Essex, CM20 2DY, UK

Phone: +44 1279 63 55 33  
Fax: +44 1279 62 50 29  
Email: [sales@jumo.co.uk](mailto:sales@jumo.co.uk)  
Internet: [www.jumo.co.uk](http://www.jumo.co.uk)

**JUMO Process Control, Inc.**

6724 Joy Road  
East Syracuse, NY 13057, USA

Phone: +1 315 437 5866  
Fax: +1 315 437 5860  
Email: [info.us@jumo.net](mailto:info.us@jumo.net)  
Internet: [www.jumousa.com](http://www.jumousa.com)

