



Construction and application of resistance thermometers

Temperature-dependent resistance

The variation of the electrical resistance of metals with temperature is very often employed for the electrical measurement of temperature. Since the electrical resistance increases with increasing temperature, we speak of a **positive temperature coefficient** or **PTC** (in platinum temperature sensors, for example).

In order to employ this effect for temperature measurement, the electrical resistance of the metal must vary in a reproducible manner depending on temperature. The characteristics of the metal must not change during operation, as this would introduce measurement errors. The temperature coefficient should be as independent as possible of temperature, pressure and chemical effects.

Standardized platinum temperature sensors

Platinum has established itself as the resistance material of choice in industrial instrumentation. Its advantages include high chemical stability, relatively easy workability (especially in wire manufacture), its availability in highly pure form, and the good reproducibility of its electrical properties. In order to ensure universal interchangeability, these properties are defined in the standard EN 60 751.

This standard lays down the electrical resistance and the permitted tolerances at different temperatures.

Additional definitions cover the nominal value of the temperature sensor and the temperature range. The calculation makes a distinction between the two temperature ranges -200 to 0°C and 0 to 850°C.

The range from -200 to 0°C is covered by the third-order polynomial:

$$R(t) = R_0(1 + A \times t + B \times t^2 + C \times (t - 100^\circ\text{C}) \times t^3)$$

A second-order polynomial applies to the range 0 to 850°C ...

$$R(t) = R_0(1 + A \times t + B \times t^2)$$

...with the coefficients:

$$A = 3,9083 \times 10^{-3} \text{ } ^\circ\text{C}^{-1}$$

$$B = -5,775 \times 10^{-7} \text{ } ^\circ\text{C}^{-2}$$

$$C = -4,183 \times 10^{-12} \text{ } ^\circ\text{C}^{-4}$$

The term R_0 is referred to as the **nominal value**, and represents the resistance at 0°C.

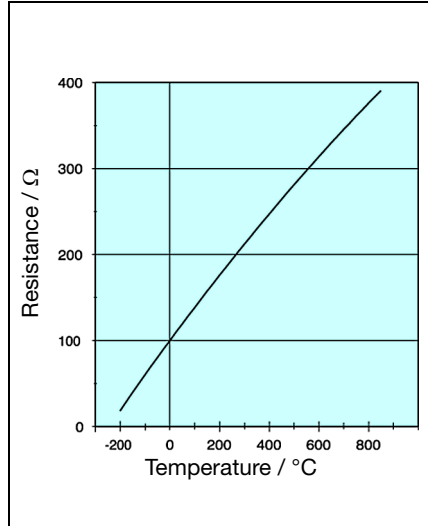

Fig. 1: Pt100 characteristic

According to EN 60 751, the nominal value is 100.000 Ω at 0°C. We therefore speak of a Pt100 temperature sensor.

Temperature sensors with nominal values of 500 and 1000Ω are also available. Their advantage is a higher sensitivity, i.e. a larger variation of their resistance with temperature.

The resistance change in the temperature range up to 100°C is approximately:

0.4Ω/°C for Pt100 temperature sensors
 2.0Ω/°C for Pt500 temperature sensors
 4.0Ω/°C for Pt1000 temperature sensors
 As an additional parameter, the standard defines a mean temperature coefficient between 0°C and 100°C. This represents the average change in resistance, referred to the nominal value at 0°C:

$$\alpha = \frac{R_{100} - R_0}{R_0 \times 100^\circ\text{C}} = 3,850 \times 10^{-3} \text{ } ^\circ\text{C}^{-1}$$

R_0 and R_{100} are the resistances at the temperatures 0°C and 100°C respectively.

Calculating the temperature from the resistance

In its application as a thermometer, the resistance of the temperature sensor is used to calculate the corresponding temperature. The formulae above represent the variation of electrical resistance with temperature.

For temperatures above 0°C it is possible to derive an explicit expression from the characteristic according to EN 60 751:

$$t = \frac{-R_0 \times A + [(R_0 \times A)^2 - 4 \times R_0 \times B \times (R_0 - R)]^{1/2}}{2 \times R_0 \times B}$$

R = measured resistance in Ω
 t = calculated temperature in °C
 R_0, A, B = parameter as per IEC 751

Tolerance limits

EN 60 751 distinguishes between two tolerance classes:

Class A: $\Delta t = \pm (0.15 + 0.002 \times |t|)$
 Class B: $\Delta t = \pm (0.30 + 0.005 \times |t|)$

t = temperature in °C (without sign)

The formula for calculating the tolerance ΔR in Ω at a temperature of $t > 0^\circ\text{C}$ is:

$$\Delta R = R_0(A + 2 \times B \times t) \times \Delta t$$

For $t < 0^\circ\text{C}$ it is:

$$\Delta R = R_0(A + 2 \times B \times t - 300^\circ\text{C} \times C \times t^2 + 4 \times C \times t^3) \times \Delta t$$

Tolerance Class A applies for temperatures between -200 and +600°C.

Tolerance Class B covers the entire definition range of -200 to +850°C.

Extended tolerance classes

It is frequently found that the two tolerance classes specified in the standard are not adequate to meet particular requirements. On the basis of the standard tolerances, **JUMO** have defined additional classes in order to meet the different requirements of the market.

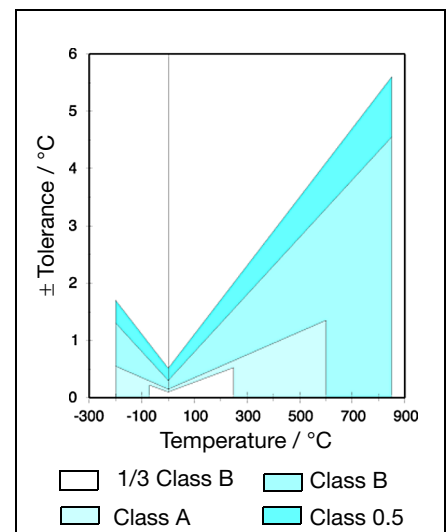

Fig. 2: Tolerance variation, depending on measurement temperature



Tolerance class	Sensor category	Temperature range	Tolerance in K
Class 1/3 DIN B	Thin-film Wire	-50 to +200°C -70 to +250°C	$\pm (0.10K + 0.0017 \times t_{tl})$
Class A	Thin-film Wire	-70 to +300°C -200 to +600°C	$\pm (0.15K + 0.002 \times t_{tl})$
Class B	Thin-film Wire	-70 to +600°C -200 to +850°C	$\pm (0.30K + 0.005 \times t_{tl})$
Class 0.5	Thin-film Wire	-70 to +600°C -200 to +850°C	$\pm (0.50K + 0.006 \times t_{tl})$

Table 1: Tolerance classes - Temperature validity range

t_{tl} = measured temperature in °C (without sign)

Construction of resistance thermometer probes

Apart from the virtually unlimited number of special models, there is also a series of probes whose components are completely defined by standard specifications.

Resistance thermometers with terminal head

These **resistance thermometers** are of modular construction, consisting of the measurement insert, protection tube, the terminal head and the terminal plate inside the head. A flange or a screw fitting can also be provided.

The **temperature sensor** is that part of the resistance thermometer which is directly affected by the measured temperature.

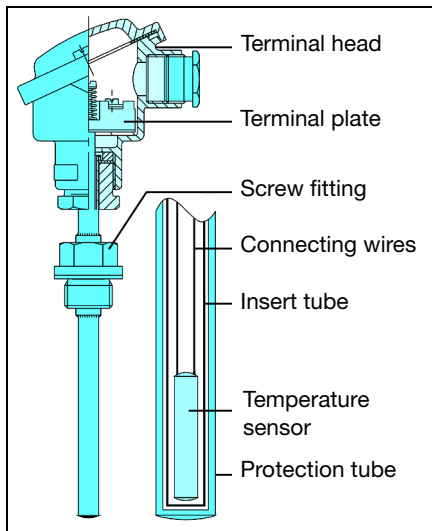

Fig. 3: Construction of an electrical thermometer

Measuring inserts are completely fabricated units, consisting of a temperature sensor and a terminal plate, with the sensor contained in an **insert tube** of 6 or 8mm diameter, made from bronze SnBz6 as per DIN 17 681 (up to 300°C) or nickel. It is inserted into the actual **protection tube**, which is often made from stainless steel.

The tip of the insert tube is in full contact with the inside of the protection tube end plate, in order to ensure good heat transfer. The insert fixing screws are backed by springs so that bottom contact is maintained even with differential expansion between the insert tube and protection tube lengths. This arrangement makes it easy to replace the insert at a later date. The thermometers are available in single and twin versions. Their dimensions are specified in the standard DIN 43 762. Inserts with an integral 2-wire transmitter are also available. If no insert is used, the temperature sensor is positioned directly inside the protection tube, embedded in aluminium oxide or a thermally conducting medium. After assembly, the terminal plate is mounted inside the terminal head and the connecting wires are soldered up.

In this arrangement, the sensor cannot be changed later; the complete resistance thermometer has to be replaced.

If a **pocket** is used, the thermometer can be removed without having to drain or depressurize the system.

The pocket is a type of protection tube which is mounted permanently at the measurement site, and in which the thermometer can be inserted and fixed in position. Other forms of pocket have an internal thread, so that a thermometer can be screwed in. The thermometer can then be made simply as an insert, or have its own protection tube. This, however, results in a much poorer response. The pocket itself is welded in position (which is not possible with a protection tube, because of the thin wall of the tube) or has an external thread, usually a pipe thread.

Since pockets are in direct contact with the fluid, they have to meet the same requirements for chemical resistance and mechanical robustness as protection tubes.

For the **terminal heads**, the DIN 43 729 standard defines two forms, A and B, which differ in size and also slightly in shape.

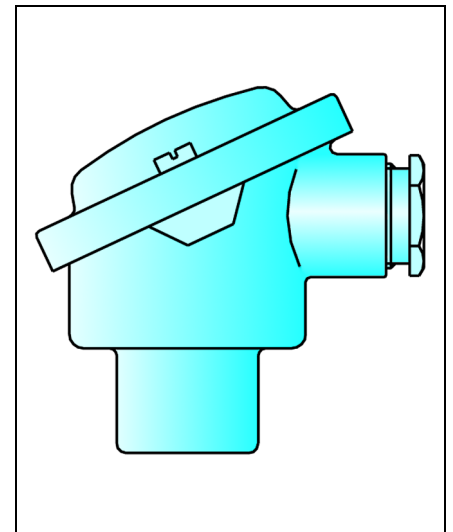

Fig. 4: Terminal head to DIN 43 729, Form B

The material used is cast iron, aluminium or plastic.

In addition, there are various other forms which are adapted to meet special requirements. The enclosure protection is not covered by the standard, it is usually a splashproof form (IP 54).

The nominal diameter of the bore in the terminal head, to take the protection tube, is: for Form A: 22, 24 or 32mm.

for Form B: 15mm or thread M 24 x 1.5.

The smaller terminal head (Form B) is the most widely used one, and the 2-wire transmitters are designed for this form.

JUMO GmbH & Co. KG
 Delivery address: Mackenrodtstraße 14,
 36039 Fulda, Germany
 Postal address: 36035 Fulda, Germany
 Phone: +49 661 6003-0
 Fax: +49 661 6003-607
 e-mail: mail@jumo.net
 Internet: www.jumo.net

JUMO Instrument Co. Ltd.
 JUMO House
 Temple Bank, Riverway
 Harlow, Essex CM 20 2TT, UK
 Phone: +44 1279 635533
 Fax: +44 1279 635262
 e-mail: sales@jumo.co.uk
 Internet: www.jumo.co.uk

JUMO Process Control, Inc.
 8 Technology Boulevard
 Canastota, NY 13032, USA
 Phone: 315-697-JUMO
 1-800-554-JUMO
 Fax: 315-697-5867
 e-mail: info@jumo.us
 Internet: www.jumo.us

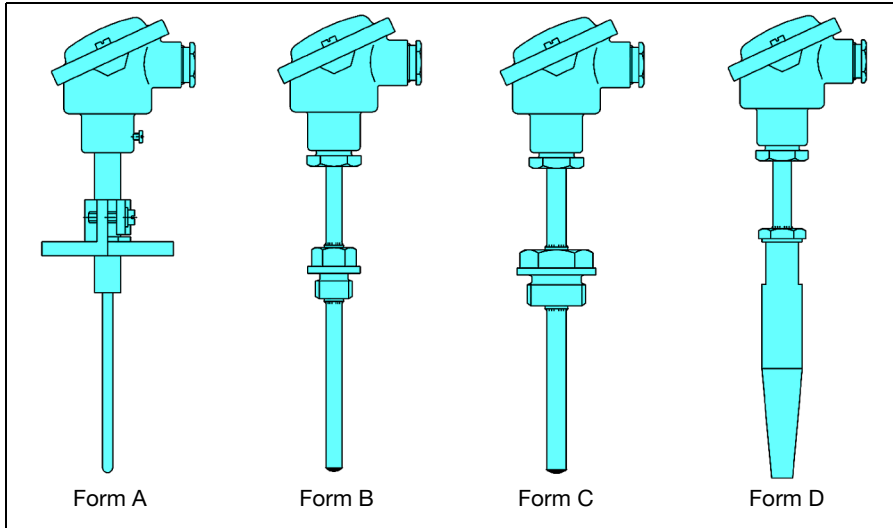

Fig. 5: Thermometers to DIN 43 770

The standards DIN 43 764 to 43 769 define various protection tube designs for different resistance thermometers and thermocouples in different applications. They are all fitted with an insert and a terminal head Form B. The diameters and lengths of the protection tubes are also fixed.

The design of the protection tubes of these thermometers (with flange, taper, etc.) are identified by code letters A to G, which themselves are laid down in DIN 43 763.

Form A: enamelled tube for mounting by sliding stop flange, for flue gas measurement

Form B: tube with fixed external 1/2" pipe thread

Form C: tube with fixed external 1" pipe thread

Form D: pressure-resistant thick-walled tube, for welding into position

Form E: tube tapering at the tip, for rapid response and mounting by sliding stop flange

Form F: tube as Code E, but with fixed flange

Form G: tube as Code E, but with fixed external 1" pipe thread

The above-mentioned standard DIN 43 763 also lays down the materials and their abbreviations in the form of special codes. For instance: the designation "Protection tube DIN 43 763-B1-H" identifies a tube to Form B, i.e. with a welded-on external 1/2" pipe thread, length 305mm (code number 1), in steel St 35.8 (code letter H). The standard also indicates the maximum pressure in air, water or steam as well as

the maximum flow velocity. This makes it easy to select the protection tubes during the design phase of system construction. There are also numerous special versions available, partly with standardized terminal heads and partly in highly specialized non-standard forms with plug connectors or attached cable.

Resistance thermometers to DIN EN 14 597

Resistance thermometers for use with temperature controllers or limiters for heating systems must meet the requirements of the standard DIN EN 14 597. These are resistance thermometers, as described in the previous section, but with an additional TUV type approval.

The resistance thermometer must withstand temperatures which are 15% above the upper temperature limit for at least one hour, and must meet specific response times, depending on the fluid (e.g. in air: $t_{0.63} = 120$ sec).

Furthermore, the thermometer must be designed to withstand mechanical loading caused by the external pressure and the flow rate of the medium, at the operating temperatures.

Alterations to such thermometers are not permitted without obtaining a fresh TUV approval!

Explosion-protected resistance thermometers

In all areas where flammable materials are stored, processed or manufactured, there is a possibility that, in combination with air, an explosive atmosphere may be formed which represents a hazard to the environment. The necessary conditions and requirements which electrical equipment has to meet in order that it can be used in an area exposed to an explosion hazard are summarized in the European Standards EN 50 014 ... EN 50 020. Equipment that conforms to these standards can therefore be used throughout Europe.

Pressure-tight enclosure EEx "d"

Transducers in pressure-tight enclosures are designed so that all components which could ignite an explosive atmosphere are safely enclosed in the protective fitting or in the terminal head. Any explosion produced inside can therefore not be propagated to the outside. This is achieved by close tolerances, special cable glands and a particularly robust construction of the terminal head. Advantages of this version:

- an intrinsically safe power supply is not required
- connection in 2-wire, 3-wire or 4-wire circuit is possible
- also available with 2-wire transmitter

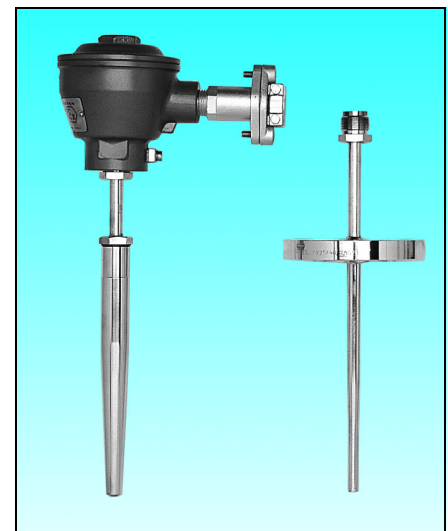

Fig. 6: Resistance thermometer in pressure-tight enclosure EEx "d"

Intrinsic safety EEx "i"

By contrast with protection "d", which refers generally to the actual device, protection "i" always considers the complete circuit.

JUMO GmbH & Co. KG
 Delivery address: Mackenrodtstraße 14,
 36039 Fulda, Germany
 Postal address: 36035 Fulda, Germany
 Phone: +49 661 6003-0
 Fax: +49 661 6003-607
 e-mail: mail@jumo.net
 Internet: www.jumo.net

JUMO Instrument Co. Ltd.
 JUMO House
 Temple Bank, Riverway
 Harlow, Essex CM 20 2TT, UK
 Phone: +44 1279 635533
 Fax: +44 1279 635262
 e-mail: sales@jumo.co.uk
 Internet: www.jumo.co.uk

JUMO Process Control, Inc.
 8 Technology Boulevard
 Canastota, NY 13032, USA
 Phone: 315-697-JUMO
 1-800-554-JUMO
 Fax: 315-697-5867
 e-mail: info@jumo.us
 Internet: www.jumo.us



In this form of resistance thermometer, the intrinsically safe 2-wire transmitter with a 4 – 20 mA output signal is located directly inside the enlarged terminal head of the thermometer, and is included in an intrinsically safe circuit.

This arrangement offers decisive advantages:

- interference-free output signal, directly from the thermometer
- low installation cost
- no lead compensation required
- signal can be transmitted over long distances
- installation and repair while the system is in operation

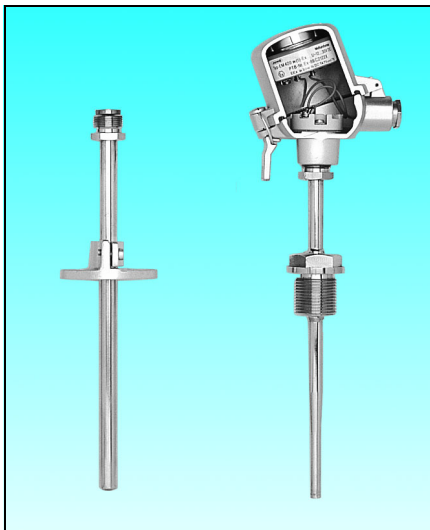

Fig. 7: Resistance thermometer with intrinsic safety EEx "i"

Resistance thermometers with 2-wire transmitters

Resistance thermometers with transmitter are used for measuring temperatures in liquids and gases when measurement signals have to be transmitted over considerable distances, free from interference. The transmitter converts the sensor signal into a standard 4 – 20mA current signal which is linear with temperature.

The supply for the transmitter is fed through the same connections, utilizing the quiescent current level of 4 mA. Because of the zero offset, this method is also referred to as "live zero". The 2-wire transmitter amplifies the signal and achieves a considerable reduction in its sensitivity to interference. In these styles, the 2-wire transmitter is encapsulated in epoxy resin and mounted directly inside the terminal head of the resistance thermometer.

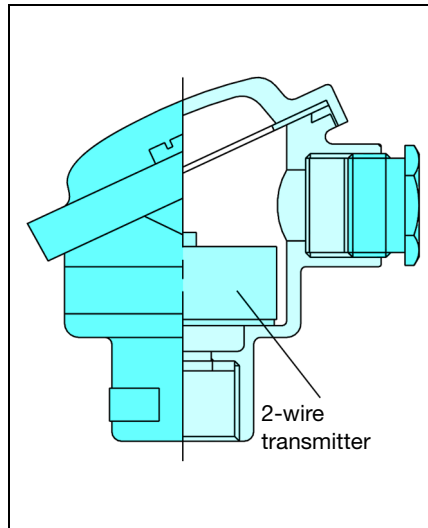

Fig. 8: Terminal head with a 2-wire transmitter

The transmitter is suitable for operating temperatures up to 90°C. Terminal heads are available in Forms BUZ, BBK and BUZH, as well as the standard Form B.

Resistance thermometers with connecting cable

On resistance thermometers with a connecting cable, the insert and terminal head are omitted. The temperature sensor is joined directly to the connecting cable, and placed in the protection tube. Strain relief is provided, for instance by grooving or compressing the end of the protection tube several times (enclosure IP65). The internal space between the protection tube and the temperature sensor is normally filled with thermally conductive material to improve the thermal contact to the fluid being measured. The maximum operating temperature is determined mainly by the temperature limit for the sheathing and insulating material of the connecting cable. The table shows some typical materials and their temperature limits.

Material	t _{max} /°C
PVC	80
PVC 105	105
Silicone	180
PTFE	260

The thermometers are available in many different styles, which are frequently designed to suit particular user requirements.

Some typical data values are:

- diameter: 2 – 8 mm
- protection tube length: 35 – 150 mm
- protection tube material: stainless steel, brass, coated steel
- circuit connection: 2, 3, or 4-wire
- mounting: flange with union connector, fixed nipple and clamping nipple

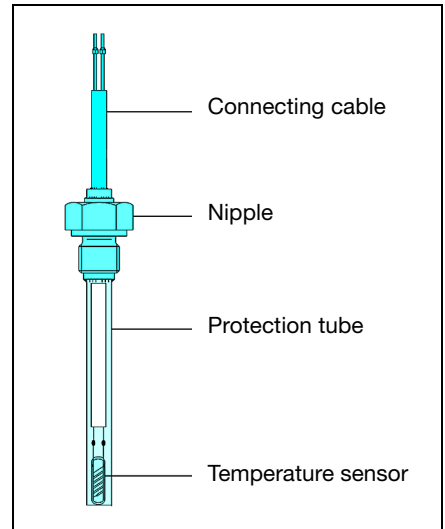

Fig. 9: Construction of a resistance thermometer with attached cable

Another type is resistance thermometers for sterilizers.

The temperature probes must have an especially high reliability, since these installations usually operate 24 hours a day. The transition from the protection tube to the connecting cable is sealed steam-tight and can withstand absolute pressures of 0.1 to 4 bar at temperatures up to 150°C. The basic versions are fitted with high-temperature PTFE connecting cables and smooth protection tubes. Up to three Pt100 temperature sensors to EN 60 751 can be fitted in these temperature probes (see Data Sheet 90.2830).

Mineral-insulated resistance thermometers

Mineral-insulated resistance thermometers are constructed using a mineral-insulated cable. The thin stainless-steel cable sheath contains the copper conductors embedded in compressed, fire-resistant magnesium oxide. The temperature sensor (in 2-, 3- or 4-wire circuit) is connected to the internal conductors and fitted into the stainless steel protection tube, which is welded to the cable sheath. Diameters as small as 1.9 mm are available.

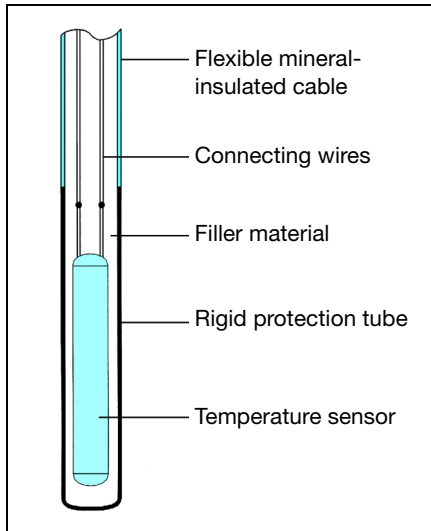

Fig. 10: Construction of a mineral-insulated resistance thermometer

The excellent heat transfer between the **protection tube** and the temperature sensor leads to a fast response ($t_{0.5}$ from 1.2 sec) and high accuracy. The shockproof construction ensures a long life. The flexible **mineral-insulated cable**, with a minimum bending radius of 5 x outside diameter (1.9/3/6mm), permits temperature measurement at relatively inaccessible locations. Because of their special properties, mineral-insulated resistance thermometers are used in chemical plant, power stations, pipelines, in engines, on test beds and in all locations where flexibility and problem-free installation are required.

Heat meter resistance thermometers

Resistance thermometers for heat meters have a federal type approval from the German Physikalisch-Technische-Bundesanstalt (PTB). The various styles meet the requirements of the Draft European Standard EN 1434 and are recommended by the German District Heating Association (AGFW = Arbeitsgemeinschaft für Fernwärme). **Thermometers with a terminal head** are available for direct temperature measurement as well as for use in suitable close-fitting pockets. The fitting length varies from 85 to 400mm. A variant is the **resistance thermometer with attached cable**, as a screw-in or push-in version. Screw-in resistance thermometers with an M 10x1 thread measure temperature directly inside the liquid, with the advantages of fast response and low heat conduction error. Using push-in thermometers in close-fitting pockets makes it unnecessary to drain the system when replacing the

thermometer at the end of the certification period. The ideal locations for screw-in resistance thermometers with an attached cable are ball valves for 1/2", 3/4" and 1" pipes. The special design of the ball valves makes it unnecessary to drain the system when fitting or replacing the temperature probe. The small pipe diameters lead to a fitting length no greater than 30mm. This gives rise to a heat conduction error which affects the measurement. The optimized internal construction of **JUMO** resistance thermometers results in a negligible heat conduction error of less than 0.03°C, and is thus even lower than the PTB specification of 0.1°C.

Insertion resistance thermometers

The design is essentially a resistance thermometer with attached cable, which is fitted with a handle. Special features of this thermometer style are: it is unaffected by alternating temperatures, sealed against water (vapor), resistant to mechanical shock and vibration. The temperature sensor in 2-wire or 3-wire circuit is inserted into the protection tube which is then sealed. The stainless steel protection tube is 100 mm long and has a concentric point or angled tip. The handles in PTFE, PPS plastics or HTV silicone are resistant to a large number of aggressive media. The connecting cable has PTFE insulation for good heat resistance.

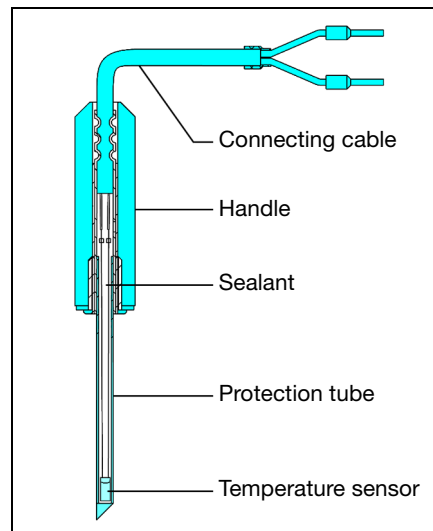

Fig. 11: Construction of an insertion resistance thermometer

A special feature of the internal construction is the sealing, which withstands high temperatures and prevents entry of water (vapor).

Surface resistance thermometers

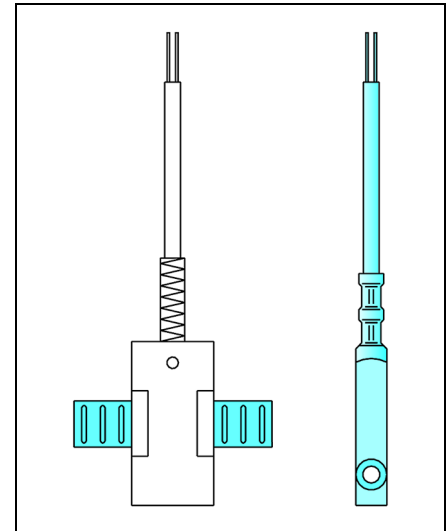

Fig. 12: Surface resistance thermometers

Surface resistance thermometers are used preferably for measuring temperatures on closed pipe systems and other round or flat surfaces. Simple installation by tension bands or hose clips avoids any mechanical preparation of the measurement location. Other versions have a mounting hole, for securing to any form of surface by a screw. Indirect temperature measurement avoids disturbing the flow of the liquid or gas. In addition, pressure and chemical effects do not influence the life of the resistance thermometer.

The object being measured is hardly affected by the small thermal mass. Heat-conductive paste can be used to improve the heat transfer. Large temperature differences between the gas/liquid and the surroundings have a direct effect on the measurement. In such cases, it is advisable to provide the thermometer with thermal insulation.

Indoor and outdoor resistance thermometers

Different versions are available for temperature measurement indoors and in the open. In the **domestic version**, the temperature sensor is enclosed in an elegant plastic housing with IP20 protection. On **outdoor thermometers for industrial use**, with IP65 protection, the temperature sensor is mounted outside the housing and enclosed by a protective cap.

JUMO GmbH & Co. KG
 Delivery address: Mackenrodtstraße 14,
 36039 Fulda, Germany
 Postal address: 36035 Fulda, Germany
 Phone: +49 661 6003-0
 Fax: +49 661 6003-607
 e-mail: mail@jumo.net
 Internet: www.jumo.net

JUMO Instrument Co. Ltd.
 JUMO House
 Temple Bank, Riverway
 Harlow, Essex CM 20 2TT, UK
 Phone: +44 1279 635533
 Fax: +44 1279 635262
 e-mail: sales@jumo.co.uk
 Internet: www.jumo.co.uk

JUMO Process Control, Inc.
 8 Technology Boulevard
 Canastota, NY 13032, USA
 Phone: 315-697-JUMO
 1-800-554-JUMO
 Fax: 315-697-5867
 e-mail: info@jumo.us
 Internet: www.jumo.us



A further version is provided with a stainless steel protection tube, into which the temperature sensor is inserted. Electrical connection is made through a Pg9 cable gland. The measuring range covers -30 to +80°C. Various versions can be fitted with a 2-wire transmitter having a 4 – 20mA output signal.

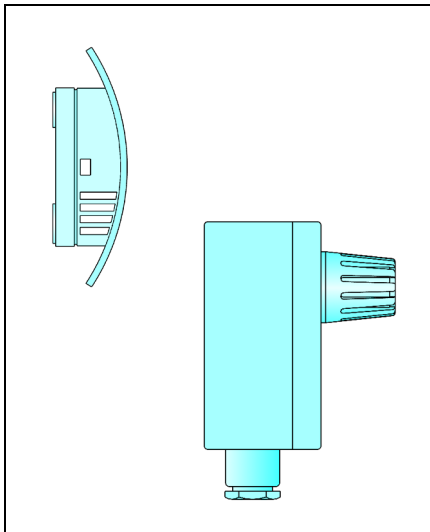

Fig. 13: Indoor and outdoor resistance thermometers

Precision resistance thermometers

For maximum stability, it is usual to arrange the resistance coil freely suspended inside the protection tube.

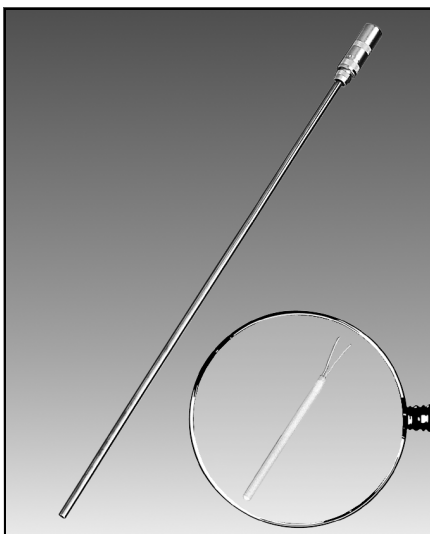

Fig. 14: Certifiable thermometer

This prevents mechanical loading under temperature, caused by differential expansion. But vibration can very easily result in a break in the coil. So, while these thermometers have excellent long-term stability, of the order of 0.001°C or less, the low

mechanical strength means that they are unsuited for industrial use. For such applications **JUMO** employs a temperature sensor with a platinum coil that is secured in a ceramic sleeve. The leads to the connector are made as a 4-wire circuit. A stainless steel tube protects the sensor from mechanical influences. The temperature range covers -200 to +450°C, depending on the version. The measurement accuracy can be up to ±0.025°C.

Measurement

Connection of resistance thermometers
 In a resistance thermometer, the electrical resistance varies with temperature. For evaluating the output signal, a constant current is passed through the thermometer and the voltage drop across it is measured. For this voltage drop, Ohm's Law states that:

$$V = R \times I$$

The measuring current should be as small as possible, in order to avoid heating of the sensor. It can be assumed that a measuring current of 1 mA does not introduce any appreciable errors. This current produces a voltage drop of 0.1 V in a Pt100 at 0°C. This signal voltage must now be transmitted through the connecting cables to the indicating or evaluation point, with a minimum of alteration.

Three different types of connecting circuit are used for this purpose:

2-wire circuit

The connection between the thermometer and the evaluation electronics is provided by a 2-core cable. Like any other electrical conductor, this cable has an electrical resistance which is in series with the temperature sensor. So the two resistances are added, and the result is a systematically higher temperature indication. For longer distances, the lead resistance may amount to a few ohms and produce an appreciable shift in the measured value. In order to avoid this error, the resistance is compensated electrically.

The instrument is designed to allow always for a lead resistance of, for instance, 10Ω. When the resistance thermometer is connected up, a compensating resistance is connected in one of the measurement lines and the sensor is replaced initially by a 100.00Ω resistor. The compensating resistance is then altered until a reading of

0°C appears on the instrument. Because of the relative large amount of work involved and the fact that effects of temperature on the measurement cable are not covered, the use of the 2-wire circuit is becoming increasingly rare.

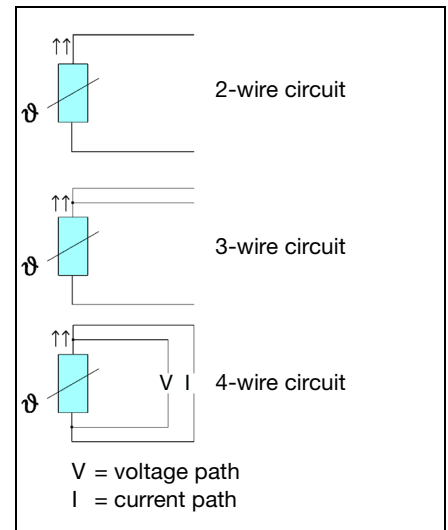

Fig. 15: Connection of resistance thermometers

3-wire circuit

The effects of the lead resistances and their fluctuation with temperature are reduced to a minimum in the 3-wire circuit. In this circuit, an additional lead is brought out to a contact on the resistance thermometer. This results in two measuring circuits, one of which is used as a reference.

The 3-wire circuit makes it possible to compensate for both the value and the temperature dependency of the lead resistance. But it is a requirement that all three cores have identical properties and are at the same temperature. In most cases, this is true to a sufficient degree of accuracy, so that the 3-wire circuit is the one most frequently used these days. No lead compensation is required.

4-wire circuit

The optimum form of connection for resistance thermometers is the 4-wire circuit. The measurement depends neither on the lead resistances nor on their variation due to temperature. No lead compensation is required. The thermometer receives the measuring current I through the supply connections. The voltage drop V across the temperature sensor is picked off by the measuring leads.

JUMO GmbH & Co. KG

Delivery address: Mackenrodtstraße 14,
36039 Fulda, Germany
Postal address: 36035 Fulda, Germany
Phone: +49 661 6003-0
Fax: +49 661 6003-607
e-mail: mail@jumo.net
Internet: www.jumo.net

JUMO Instrument Co. Ltd.

JUMO House
Temple Bank, Riverway
Harlow, Essex CM 20 2TT, UK
Phone: +44 1279 635533
Fax: +44 1279 635262
e-mail: sales@jumo.co.uk
Internet: www.jumo.co.uk

JUMO Process Control, Inc.

8 Technology Boulevard
Canastota, NY 13032, USA
Phone: 315-697-JUMO
1-800-554-JUMO
Fax: 315-697-5867
e-mail: info@jumo.us
Internet: www.jumo.us



If the input resistance of the electronics is many times greater than the lead resistance, then the latter can be neglected. The voltage drop determined in this way is independent of the properties of the connecting wires.

With both 3-wire and 4-wire circuits it must be remembered that the circuit is not always taken right up to the actual sensing element. The connection from the sensor to the terminal head of the fitting, the so-called internal connection, is frequently made in a 2-wire circuit. This results in similar problems to those discussed for the 2-wire circuit, although to a much smaller extent. The total resistance, consisting of the sum of internal connection and sensor, is defined by DIN 16 160 as the **thermometer resistance**.

Insufficient insulation resistance

Because of the finite resistance between the connections and within the insulation material in which the sensor is embedded, there is a possibility of a further error due to poor insulation resistance which reduces the indicated temperature. Based on a Pt100 thermometer, an insulation resistance of 100 kΩ results in an error of 0.25°C, and 25 kΩ one of 1°C. Because of the variation of insulation resistance with temperature, it is possible for this error to vary with the measuring conditions. For ceramic insulating materials in particular, the resistance decreases with increasing temperature.

In view of the relatively low maximum temperature of about 600°C, this effect is hardly noticeable for platinum temperature sensors. Much more important is any moisture which may penetrate the insulation, as this can cause a substantial measurement error. Sensors are therefore usually covered by a glaze or some other form of hermetic sealing. The measuring insert itself is also sealed, in order to prevent entry of moisture into the probe tube. Inserts are readily interchangeable, since they are completely enclosed units. For resistance thermometers without inserts, on the other hand, it is vital to ensure a reliable seal if they have to be repaired.

Self-heating

The output signal of a resistance thermometer can only be measured by passing a current through the sensor. This measurement current produces a power loss and therefore heats up the sensor, with the re-

sult that the temperature indication is increased. Self-heating depends on a number of factors, including the extent to which the heat generated can be removed by the fluid (or gas) being measured. Because the relationship for electrical power is $P = R \times I^2$, the effect depends also on the basic resistance of the temperature sensor. For the same measurement current, a Pt1000 temperature sensor is heated ten times as much as a Pt100. In addition, design features (thermometer size) and thermal conduction and capacity also determine the error. The thermal capacity of the fluid and its flow velocity also have a large influence on this effect.

Thermometer manufacturers often specify a self-heating coefficient, which represents a measure for the temperature increase through a defined power loss in the sensor. Such calorimetric measurements are carried out under standard conditions (in water at 0.5m/sec, or air at 2m/sec), but the information is somewhat theoretical and serves only for comparison between different designs.

In most cases, the measurement current is set at 1mA by the instrument manufacturer, since this value has been found appropriate in practice and produces no appreciable self-heating.

For example, a Pt100 temperature sensor is placed in a closed and fully insulated container with 10cm³ of air, and this measurement current of 1 milliamperere increases the air temperature by 39°C after one hour. With flowing gases and liquids the effect is very much less pronounced, because of the much greater heat dissipation.

Because of differences in measurement conditions it is necessary to measure the actual self-heating effect on site. The current is varied and the corresponding temperature is measured. The self-heating coefficient E is derived as:

$$E = \Delta t / (R \times I^2)$$

where

- Δt = (indicated temperature)
– (fluid temperature),
- R = thermometer resistance
- I = measurement current

The self-heating coefficient can be used to determine the maximum measurement current if an error Δt is permitted.

$$I = (\Delta t / E \times R)^{1/2}$$

Parasitic thermal voltages

The effect of thermo-electric voltages can also be seen during temperature measurement with resistance thermometers, in this case as a highly undesirable side effect. Thermal voltages can be generated at the junction of two different metals. Such metal junctions occur at the lead connections in the resistance thermometer. The connecting wires of the sensor frequently consist of silver, with extensions of copper or nickel as internal conductors, for example.

Under normal conditions, it can be assumed that both junctions are at the same temperature and that the resulting thermal voltages cancel each other. Differences in heat conduction to the outside may however lead to the establishment of different temperatures; the resulting thermal voltage is interpreted by the electronics as a voltage drop, thus producing a measurement error.

This can take the form of an increase or a decrease, depending on the polarity of the thermal voltage which is produced.

The magnitude of the resulting error depends very much on the characteristics of the electronics, in particular on how the voltage is evaluated as a temperature.

A simple method for diagnosing such errors consists of performing two measurements with the measurement current in opposite directions. The larger the difference between the two measurements, the greater is the thermal voltage generated.

Transfer function

A sensor will never respond instantaneously, but always with a certain delay, because of the ever-present thermal resistances within the probe. The resulting measurement error, caused by the measurement or output signal lagging behind a change in the substance being measured, is known as the **dynamic error**.

As a simplification, it is possible to think of the probe as consisting of a combination of resistances and energy stores. The material masses and the corresponding thermal capacities form the energy stores. The materials have different thermal conductivities which cause the resistances. The components of the thermometer often have both characteristics simultaneously.



The speed with which the thermometer responds depends in the first instance on the ratio of the thermal resistance to the thermal capacity of the probe. The larger this thermal resistance, the slower the probe heats up. So in order to achieve a fast response it is desirable to use small sensors and thin materials which conduct heat readily. A particularly unfavourable feature is the air gap between the measurement insert and its protection tube, since all gases are poor heat conductors. The remedy consists of embedding the insert in thermally conductive pastes or metal oxides. Thermocouples have essentially shorter response times than resistance thermometers, because of their lower thermal mass. This applies in particular to thin mineral-insulated thermocouples. However, in most cases the difference is largely outweighed by the comparatively high thermal capacity of the protective fitting. The response time generally increases with increasing protection tube diameter. It is therefore advisable to use thin-walled fittings of small diameter, as far as the mechanical circumstances allow.

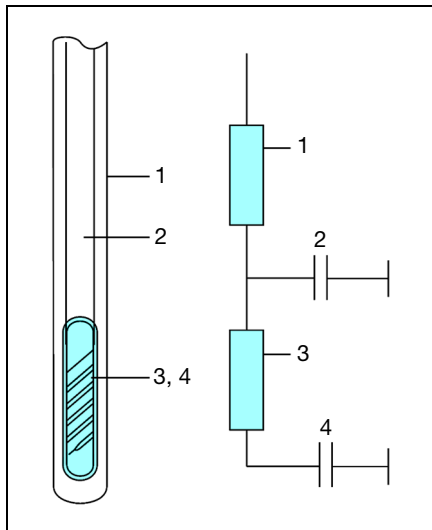

Fig. 16: Thermal resistances in a thermometer

The thermal conductivity of the protection tube material is also very important. Copper and iron are comparatively good heat conductors, but stainless steel and ceramics are not so good.

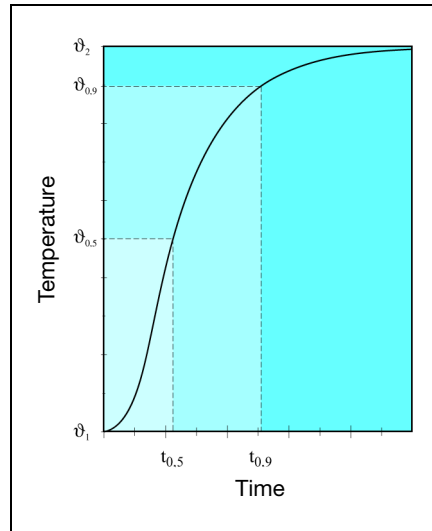

Fig. 17: The transfer function

The **transfer function**, i.e. the variation of the measured value following a sudden change in temperature, provides information on this effect. Tests to determine the transfer function of the thermometer are carried out in a flow of warm water or air, using special test set-ups, as specified for example in EN 60 751. Two times (response periods) characterize the transfer function:

- **Half-value time $t_{0,5}$**
 The half-value time indicates the period during which the measured value reaches 50% of its final value.
- **90%-time $t_{0,9}$**
 The 90%-time indicates the period during which the measured value reaches 90% of its final value.

A time τ taken to reach 63.2% of the final value is not generally specified, because of possible confusion with the time constant of an exponential function. The heat transfer function of virtually all thermometers deviates clearly from such a function.

Errors in resistance thermometers

Effect of the cable

In measurements using resistance thermometers, the results may be falsified by design features or measurement effects. The following section explains the most important effects which may cause erroneous measurements.

As described elsewhere, the lead resistance enters into the measurement as a resistor in series with the sensor.

Particularly in large installations, with the resulting longer transmission distances, the lead resistance can reach the same order of magnitude as the sensor resistance itself. Compensation of the lead resistance is therefore absolutely essential, and usually consists of shifting the zero of the instrument connected to the sensor. However, such compensation does not take account of the changes in the lead resistance with temperature. If the connecting cable is subjected to fluctuating temperatures, this will lead to varying degrees of measurement error. The effect only becomes apparent with larger lead resistances, i.e. with longer cable lengths and small conductor cross-sections.

Heat conduction error

A thermometer is rarely used in the range of ambient temperatures. If the measured temperature is above or below the ambient temperature, a temperature gradient will result at the thermometer, between the measurement point and the surroundings. This leads to an error in the temperature indication: heat flows through the protection tube and the internal components from the hotter to the cooler location. In addition, the sensor is connected to the cable, forming a direct metallic contact between the sensor and the surroundings – a thermal bridge which also causes an error. Good electrical conductors always have a low thermal resistance, so the requirement for a lower lead resistance is counteracted by a higher heat conduction error. Furthermore, the design of the thermometer influences the heat conduction error. The sensor must have a good thermal connection to the protection tube, but at the same time be thermally decoupled from the connecting cable. The installation length of the thermometer must not be made too short, otherwise too much heat will be dissipated. The **immersion depth** (the length of the portion of the thermometer which is exposed to the medium being measured) depends on the type of medium and the rate at which it transports heat. For example, a fast-flowing liquid will transfer more heat than still air, and will therefore provide better compensation for the heat conduction of the thermometer. Measurements in liquids only require about half of the installation length compared with that used with gases.

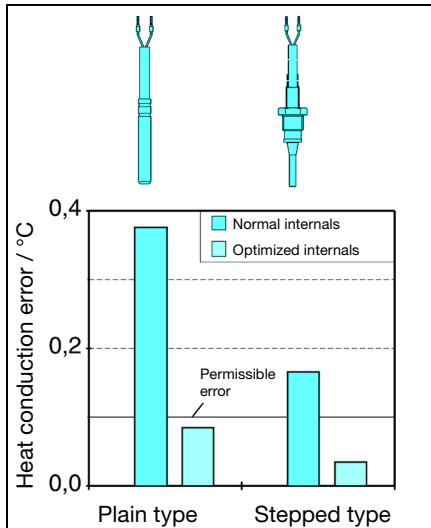

Fig. 18: Optimizing the heat conduction error, through protection tube geometry and internal layout

An example will demonstrate the effect of design on the heat conduction error. When used with heat meters, thermometers must have a heat conduction error not exceeding 0.1°C under the following conditions:

- Measured temperature: 80°C,
- Ambient temperature: 20°C,
- Measured medium: water, at a flow velocity of 0.1 to 0.2 m/sec

Particularly in short temperature probes with a fitting length less than 50mm, the achievement of the accuracy specified above raises problems which have to be solved through the design. The connecting cable is taken right up to the sensor and consists of copper. The thermal interface between sensor and protection tube is usually provided by heat conductive paste.

In the absence of any special precautions for thermal decoupling, there is a heat conduction error of about 0.3°C.

A 50% improvement is achieved by reducing the protection tube diameter in the region of the sensor. The error of 0.15°C for this probe version is still not adequate to meet the test criteria. Finally, a thermal decoupling of the connecting cable from the sensor reduces the heat conduction error to 0.03°C, which is now a factor of 10 better than the original version.

Measures for reducing the heat conduction error

It is not always possible to optimize the probe design for a particular measurement application so that the result is not affected by heat conduction errors. The publication "Electrical Temperature Measurement", described on page 15, summarizes the most important selection criteria for a probe with regard to heat conduction errors.

Calibration

During its operational life, a thermometer experiences changes in its characteristic compared with its original ex-factory condition, because of chemical and mechanical effects, as well as through ageing phenomena such as recrystallization and diffusion. In order to allow for drift and to compensate for it, it is necessary to recalibrate the thermometer at regular intervals.

cannot predict the future application and frequency of use, and the resulting stresses on the thermometer. It is advisable to recalibrate a thermometer initially every year and to compare the results with the previous calibration data. In the course of time, this produces a life history of the thermometer, from which its stability can be seen.

Depending on whether the reproducibility is adequate or not for the particular application, the recalibration period can then be extended or shortened.

The question concerning the actual details and the accuracy of a calibration cannot be answered in general terms. It is always subject to agreement between the user and the calibration laboratory, including temperature ranges and test points. The accuracy is determined by the type of measurement that is applied.

The German Calibration Service (Deutscher Kalibrierdienst, DKD)

The opening of the internal European trade boundaries after 1992, the new quality standards such as ISO 9001, and the more stringent product liability regulations make increasing demands on the documentation of processes and on the monitoring of measuring devices. In addition, there is an increasing demand from users for higher product quality standards. A particularly stringent requirement arises from the ISO 9001 standard, which describes the global concept of a quality assurance system.

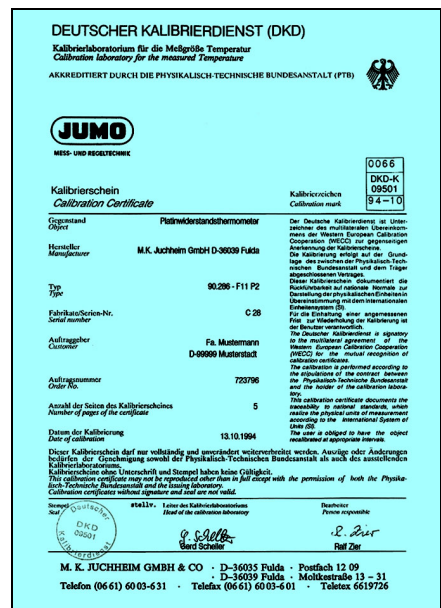

Fig. 19: Calibration certificate

Recalibration consists of checking the indicated temperature values and, where appropriate, recording the amounts by which they deviate from the true temperatures. By contrast, the concept of **adjustment**, which is often used in this connection, means altering the instrument to render the deviation small, at least to within the tolerance limits.

Calibration is identical with testing and measuring the accuracy for each individual thermometer. The manufacturer is, however, unable to provide any guarantee for the long-term stability of these values, since he

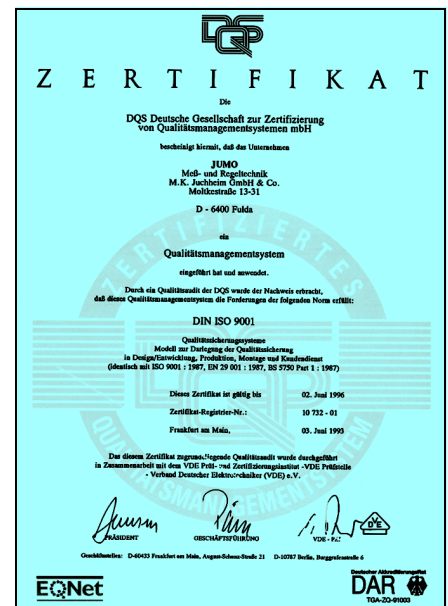

Fig. 20: Certificate to ISO 9001

JUMO GmbH & Co. KG
 Delivery address: Mackenrodtstraße 14,
 36039 Fulda, Germany
 Postal address: 36035 Fulda, Germany
 Phone: +49 661 6003-0
 Fax: +49 661 6003-607
 e-mail: mail@jumo.net
 Internet: www.jumo.net

JUMO Instrument Co. Ltd.
 JUMO House
 Temple Bank, Riverway
 Harlow, Essex CM 20 2TT, UK
 Phone: +44 1279 635533
 Fax: +44 1279 635262
 e-mail: sales@jumo.co.uk
 Internet: www.jumo.co.uk

JUMO Process Control, Inc.
 8 Technology Boulevard
 Canastota, NY 13032, USA
 Phone: 315-697-JUMO
 1-800-554-JUMO
 Fax: 315-697-5867
 e-mail: info@jumo.us
 Internet: www.jumo.us



If a manufacturer wishes to issue certificates based on this standard, it is necessary that the testing devices involved in production can be traced back to recognized national standards.

Traceability to a national standard means that in the checking of a testing device, the actual measurements are documented so that they can be traced back to legal instrument standards. In Germany, the PTB (Physikalisch-Technische-Bundesanstalt) lays down the national standards and compares them with the results from other organizations so that the representation of important parameters such as temperature can be ensured uniformly by physical means throughout the world.

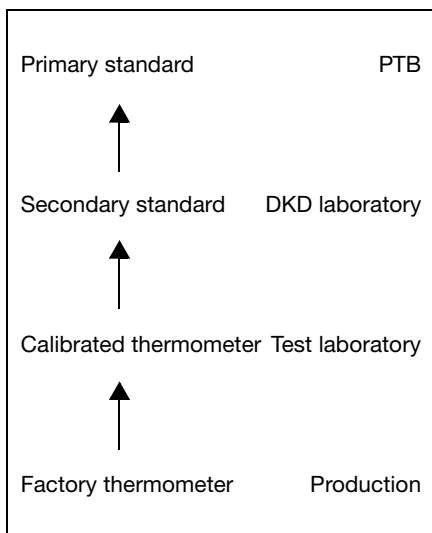

Fig. 21: Traceability

Because of the large demand for such calibrated devices, the government laboratories are found to have insufficient capacity and industry has therefore established and supports special calibration laboratories. These laboratories, including the **JUMO DKD Laboratory for Temperature 9501**, are linked to the German Calibration Service (DKD) and are subordinate to the national PTB laboratory for instrumental aspects. This ensures that the measuring devices used in a DKD laboratory can be traced back unequivocally to the national standards, and therefore also to the thermometers used there.

Safety note

All welded joints on thermometers and pockets are monitored through a fundamental quality assurance system according to DIN 85 63, Part 113. Special safety regulations apply to the "Mandatory monitored area" (e.g. pressure vessels) according to Section 24 of the German Trade Regulations. In cases where the customer specifies such an application, the welding is monitored according to EN 287 and EN 288.

Pressure loading for temperature probes

The pressure resistance of protection fittings, such as are used for electric thermometers, depends largely on the different process parameters.

These include:

- temperature
- pressure
- flow velocity
- vibration

In addition, physical properties, such as material, fitting length, diameter and type of process connection have to be taken into account.

The diagrams below are taken from DIN 43 763 and show the load limit for the different basic types in relation to the temperature and the fitting length, as well as the flow velocity, temperature and medium.

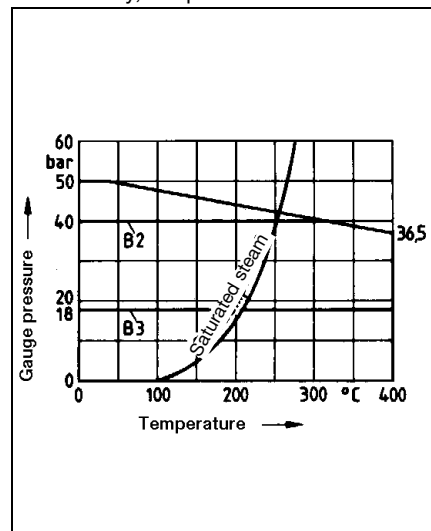

Fig. 22: Pressure loading for Form B protection tubes

stainless steel 1.4571
 velocity up to 25m/sec in air
 velocity up to 3m/sec in water

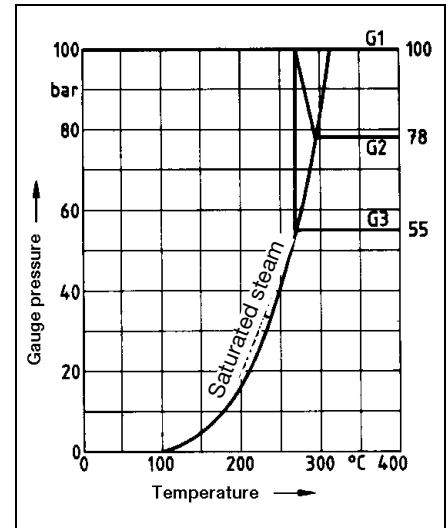

Fig. 23: Pressure loading for Form G protection tubes

stainless steel 1.4571
 velocity up to 40m/sec in air
 velocity up to 4m/sec in water

JUMO GmbH & Co. KG
 Delivery address: Mackenrodtstraße 14,
 36039 Fulda, Germany
 Postal address: 36035 Fulda, Germany
 Phone: +49 661 6003-0
 Fax: +49 661 6003-607
 e-mail: mail@jumo.net
 Internet: www.jumo.net

JUMO Instrument Co. Ltd.
 JUMO House
 Temple Bank, Riverway
 Harlow, Essex CM 20 2TT, UK
 Phone: +44 1279 635533
 Fax: +44 1279 635262
 e-mail: sales@jumo.co.uk
 Internet: www.jumo.co.uk

JUMO Process Control, Inc.
 8 Technology Boulevard
 Canastota, NY 13032, USA
 Phone: 315-697-JUMO
 1-800-554-JUMO
 Fax: 315-697-5867
 e-mail: info@jumo.us
 Internet: www.jumo.us



As explained in the standard, the values indicated are guide values, which have to be individually examined for the specific application. Slight differences in the measurement conditions may suffice to destroy the protection tube.

If, when ordering an electric thermometer, it is required that the protection fitting be checked, the load type and the limit values have to be specified.

Fig. 24 shows the load limits (guide values) for different tube dimensions on a variety of additional thermometer designs. The maximum pressure loading of cylindrical protection tubes is shown in relation to the wall thickness with different tube diameters. The data refer to protection tubes in stainless steel 1.4571, 100mm fitting length, 10m/sec flow velocity in air, or 4m/sec in water, and a temperature range from -20 to +100°C. A safety factor of 1.8 has been taken into account. For higher temperatures or different materials, the maximum pressure loading has to be reduced by the percentage values given in the table.

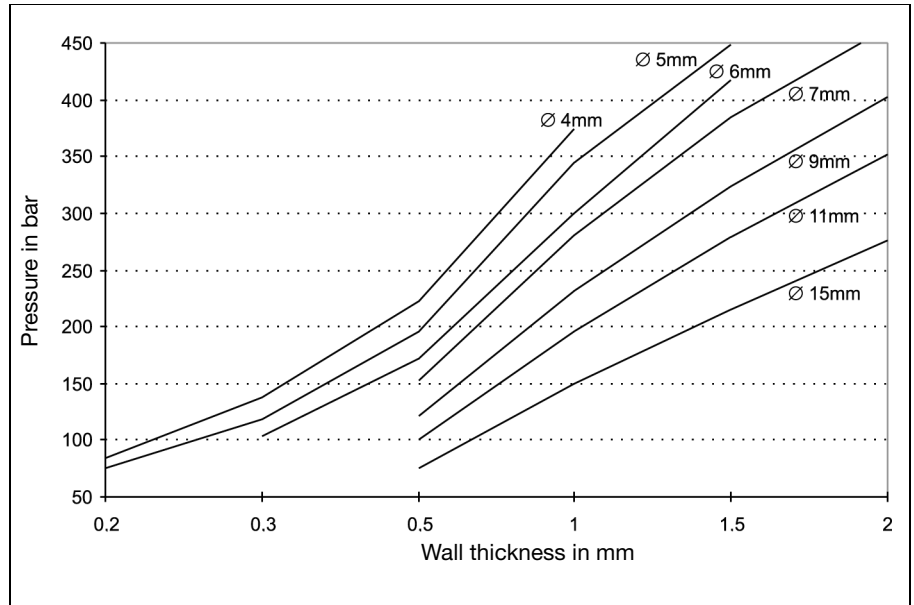

Fig. 24: Load limits on protection tubes, for various tube dimensions

Material	Temperature	Reduction
CrNi 1.4571	up to +200°C	-10%
CrNi 1.4571	up to +300°C	-20%
CrNi 1.4571	up to +400°C	-25%
CrNi 1.4571	up to +500°C	-30%
CuZn 2.0401	up to +100°C	-15%
CuZn 2.0401	up to +175°C	-60%

JUMO GmbH & Co. KG
 Delivery address: Mackenrodtstraße 14,
 36039 Fulda, Germany
 Postal address: 36035 Fulda, Germany
 Phone: +49 661 6003-0
 Fax: +49 661 6003-607
 e-mail: mail@jumo.net
 Internet: www.jumo.net

JUMO Instrument Co. Ltd.
 JUMO House
 Temple Bank, Riverway
 Harlow, Essex CM 20 2TT, UK
 Phone: +44 1279 635533
 Fax: +44 1279 635262
 e-mail: sales@jumo.co.uk
 Internet: www.jumo.co.uk

JUMO Process Control, Inc.
 8 Technology Boulevard
 Canastota, NY 13032, USA
 Phone: 315-697-JUMO
 1-800-554-JUMO
 Fax: 315-697-5867
 e-mail: info@jumo.us
 Internet: www.jumo.us



Pressure test for thermometer protection fittings

The welded protection fittings of JUMO thermometers are subjected to a leakage test or a pressure test, depending on the construction of the protection fitting.

Thermometers which are manufactured to DIN or to application-specific guidelines (chemical or petrochemical plant, pressure vessel regulation, steam boilers) require different pressure tests according to the specific application.

If the thermometers are to be manufactured to such standards or guidelines, then the required tests or standards and/or guidelines have to be specified when ordering.

Scope of test

Tests can be carried out on each individual protection fitting and documented with a test report or acceptance certificate to EN 10 204 (at extra cost).

Type of test

Tests can be performed on protection fittings up to a fitting length of 1050mm with flange connection DN25 or screw connection up to 1" thread size.

The following tests can be carried out:

Test type	Test medium	Pressure range	Test duration
Leakage test	helium	vacuum	10sec
Pressure test I	nitrogen	1 – 50bar	10sec
Pressure test II	water	50 – 300bar	10sec

Leakage test

A vacuum is produced inside the protection tube. From the outside, helium is applied to the protection fitting. If there is a leak in the protection tube, helium will penetrate and will be recognized through analysis. A leakage rate is determined by the rise in pressure (leakage rate > 1 x 10⁻⁶ l/bar).

Pressure test I

A positive pressure of nitrogen is applied to the protection tube from the outside. If there is a leak in the fitting, a volume flow will be produced inside the protection tube, which will be recognized.

Pressure test II

Water pressure is applied to the protection tube from the outside. The pressure must remain constant for a certain length of time. If this is not the case, the protection fitting has a leak.

Qualified welding processes for the production of protection tubes for thermometers

In addition to using perfect materials, it is the joining technique which, in the end, determines the mechanical stability and quality of the protection fittings. This is why the welding techniques at JUMO comply with the European Standards EN 287 and EN 288. Manual welding is carried out by qualified welders according to EN 287. Automatic welding processes are qualified by a WPS (welding instruction) to EN 288.

The following table provides an overview of the qualified welding processes:

Material	WIG welding	
	manual	automatic
W11, W11 with W01-W04 to EN 287	Tube diameter 2 – 30mm Wall thickness 0.75 – 5.6mm	Tube diameter 5 – 10mm Wall thickness 0.5 – 1.0mm

Table. 2: Qualified welding processes

Based on this experience, our welders can also join different materials and dimensions.

Laser beam welding is employed for wall thicknesses of less than 0.6mm, which is monitored by a laser beam specialist according to guideline DSV 1187.

On customers' request, material test certificates can be issued at extra cost. Likewise, special tests and treatments can be carried out, which are calculated according to the extent of the work, as set out in various application guidelines. This includes X-ray examinations, crack test (dye penetration test), thermal treatment, special cleaning processes and markings.

JUMO GmbH & Co. KG
 Delivery address: Mackenrodtstraße 14,
 36039 Fulda, Germany
 Postal address: 36035 Fulda, Germany
 Phone: +49 661 6003-0
 Fax: +49 661 6003-607
 e-mail: mail@jumo.net
 Internet: www.jumo.net

JUMO Instrument Co. Ltd.
 JUMO House
 Temple Bank, Riverway
 Harlow, Essex CM 20 2TT, UK
 Phone: +44 1279 635533
 Fax: +44 1279 635262
 e-mail: sales@jumo.co.uk
 Internet: www.jumo.co.uk

JUMO Process Control, Inc.
 8 Technology Boulevard
 Canastota, NY 13032, USA
 Phone: 315-697-JUMO
 1-800-554-JUMO
 Fax: 315-697-5867
 e-mail: info@jumo.us
 Internet: www.jumo.us



**Reference values according to EN 60 751 (ITS 90)
 in ohms, for Pt100 temperature sensors, in 1°C steps**

°C	-0	-1	-2	-3	-4	-5	-6	-7	-8	-9
-200	18.520	-	-	-	-	-	-	-	-	-
-190	22.825	22.397	21.967	21.538	21.108	20.677	20.247	19.815	19.384	18.952
-180	27.096	26.671	26.245	25.819	25.392	24.965	24.538	24.110	23.682	23.254
-170	31.335	30.913	30.490	30.067	29.643	29.220	28.796	28.371	27.947	27.522
-160	35.543	35.124	34.704	34.284	33.864	33.443	33.022	32.601	32.179	31.757
-150	39.723	39.306	38.889	38.472	38.055	37.637	37.219	36.800	36.382	35.963
-140	43.876	43.462	43.048	42.633	42.218	41.803	41.388	40.972	40.556	40.140
-130	48.005	47.593	47.181	46.769	46.356	45.944	45.531	45.117	44.704	44.290
-120	52.110	51.700	51.291	50.881	50.470	50.060	49.649	49.239	48.828	48.416
-110	56.193	55.786	55.378	54.970	54.562	54.154	53.746	53.337	52.928	52.519
-100	60.256	59.850	59.445	59.039	58.633	58.227	57.821	57.414	57.007	56.600
- 90	64.300	63.896	63.492	63.088	62.684	62.280	61.876	61.471	61.066	60.661
- 80	68.325	67.924	67.522	67.120	66.717	66.315	65.912	65.509	65.106	64.703
- 70	72.335	71.934	71.534	71.134	70.733	70.332	69.931	69.530	69.129	68.727
- 60	76.328	75.929	75.530	75.131	74.732	74.333	73.934	73.534	73.134	72.735
- 50	80.306	79.909	79.512	79.114	78.717	78.319	77.921	77.523	77.125	76.726
- 40	84.271	83.875	83.479	83.083	82.687	82.290	81.894	81.497	81.100	80.703
- 30	88.222	87.827	87.432	87.038	86.643	86.248	85.853	85.457	85.062	84.666
- 20	92.160	91.767	91.373	90.980	90.586	90.192	89.798	89.404	89.010	88.616
- 10	96.086	95.694	95.302	94.909	94.517	94.124	93.732	93.339	92.946	92.553
0	100.000	99.609	99.218	98.827	98.436	98.044	97.653	97.261	96.870	96.478

°C	0	1	2	3	4	5	6	7	8	9
0	100.000	100.391	100.781	101.172	101.562	101.953	102.343	102.733	103.123	103.513
10	103.903	104.292	104.682	105.071	105.460	105.849	106.238	106.627	107.016	107.405
20	107.794	108.182	108.570	108.959	109.347	109.735	110.123	110.510	110.898	111.286
30	111.673	112.060	112.447	112.835	113.221	113.608	113.995	114.382	114.768	115.155
40	115.541	115.927	116.313	116.699	117.085	117.470	117.856	118.241	118.627	119.012
50	119.397	119.782	120.167	120.552	120.936	121.321	121.705	122.090	122.474	122.858
60	123.242	123.626	124.009	124.393	124.777	125.160	125.543	125.926	126.309	126.692
70	127.075	127.458	127.840	128.223	128.605	128.987	129.370	129.752	130.133	130.515
80	130.897	131.278	131.660	132.041	132.422	132.803	133.184	133.565	133.946	134.326
90	134.707	135.087	135.468	135.848	136.228	136.608	136.987	137.367	137.747	138.126
100	138.506	138.885	139.264	139.643	140.022	140.400	140.779	141.158	141.536	141.914
110	142.293	142.671	143.049	143.426	143.804	144.182	144.559	144.937	145.314	145.691
120	146.068	146.445	146.822	147.198	147.575	147.951	148.328	148.704	149.080	149.456
130	149.832	150.208	150.583	150.959	151.334	151.710	152.085	152.460	152.835	153.210
140	153.584	153.959	154.333	154.708	155.082	155.456	155.830	156.204	156.578	156.952
150	157.325	157.699	158.072	158.445	158.818	159.191	159.564	159.937	160.309	160.682
160	161.054	161.427	161.799	162.171	162.543	162.915	163.286	163.658	164.030	164.401
170	164.772	165.143	165.514	165.885	166.256	166.627	166.997	167.368	167.738	168.108
180	168.478	168.848	169.218	169.588	169.958	170.327	170.696	171.066	171.435	171.804
190	172.173	172.542	172.910	173.279	173.648	174.016	174.384	174.752	175.120	175.488
200	175.856	176.224	176.591	176.959	177.326	177.693	178.060	178.427	178.794	179.161
210	179.528	179.894	180.260	180.627	180.993	181.359	181.725	182.091	182.456	182.822
220	183.188	183.553	183.918	184.283	184.648	185.013	185.378	185.743	186.107	186.472
230	186.836	187.200	187.564	187.928	188.292	188.656	189.019	189.383	189.746	190.110
240	190.473	190.836	191.199	191.562	191.924	192.287	192.649	193.012	193.374	193.736
250	194.098	194.460	194.822	195.183	195.545	195.906	196.268	196.629	196.990	197.351
260	197.712	198.073	198.433	198.794	199.154	199.514	199.875	200.235	200.595	200.954
270	201.314	201.674	202.033	202.393	202.752	203.111	203.470	203.829	204.188	204.546
280	204.905	205.263	205.622	205.980	206.338	206.696	207.054	207.411	207.769	208.127
290	208.484	208.841	209.198	209.555	209.912	210.269	210.626	210.982	211.339	211.695
300	212.052	212.408	212.764	213.120	213.475	213.831	214.187	214.542	214.897	215.252

The reference values have been calculated according to the International Temperature Scale ITS 90.
 (The reference values must be multiplied by the factor 5 or 10 for Pt500 or Pt1000 temperature sensors).

JUMO GmbH & Co. KG
 Delivery address: Mackenrodtstraße 14,
 36039 Fulda, Germany
 Postal address: 36035 Fulda, Germany
 Phone: +49 661 6003-0
 Fax: +49 661 6003-607
 e-mail: mail@jumo.net
 Internet: www.jumo.net

JUMO Instrument Co. Ltd.
 JUMO House
 Temple Bank, Riverway
 Harlow, Essex CM 20 2TT, UK
 Phone: +44 1279 635533
 Fax: +44 1279 635262
 e-mail: sales@jumo.co.uk
 Internet: www.jumo.co.uk

JUMO Process Control, Inc.
 8 Technology Boulevard
 Canastota, NY 13032, USA
 Phone: 315-697-JUMO
 1-800-554-JUMO
 Fax: 315-697-5867
 e-mail: info@jumo.us
 Internet: www.jumo.us



Reference values according to EN 60 751 (ITS 90) in ohms, for Pt100 temperature sensors, in 1°C steps

°C	0	1	2	3	4	5	6	7	8	9
310	215.608	215.962	216.317	216.672	217.027	217.381	217.736	218.090	218.444	218.798
320	219.152	219.506	219.860	220.213	220.567	220.920	221.273	221.626	221.979	222.332
330	222.685	223.038	223.390	223.743	224.095	224.447	224.799	225.151	225.503	225.855
340	226.206	226.558	226.909	227.260	227.612	227.963	228.314	228.664	229.015	229.366
350	229.716	230.066	230.417	230.767	231.117	231.467	231.816	232.166	232.516	232.865
360	233.214	233.564	233.913	234.262	234.610	234.959	235.308	235.656	236.005	236.353
370	236.701	237.049	237.397	237.745	238.093	238.440	238.788	239.135	239.482	239.829
380	240.176	240.523	240.870	241.217	241.563	241.910	242.256	242.602	242.948	243.294
390	243.640	243.986	244.331	244.677	245.022	245.367	245.713	246.058	246.403	246.747
400	247.092	247.437	247.781	248.125	248.470	248.814	249.158	249.502	249.845	250.189
410	250.533	250.876	251.219	251.562	251.906	252.248	252.591	252.934	253.277	253.619
420	253.962	254.304	254.646	254.988	255.330	255.672	256.013	256.355	256.696	257.038
430	257.379	257.720	258.061	258.402	258.743	259.083	259.424	259.764	260.105	260.445
440	260.785	261.125	261.465	261.804	262.144	262.483	262.823	263.162	263.501	263.840
450	264.179	264.518	264.857	265.195	265.534	265.872	266.210	266.548	266.886	267.224
460	267.562	267.900	268.237	268.574	268.912	269.249	269.586	269.923	270.260	270.597
470	270.933	271.270	271.606	271.942	272.278	272.614	272.950	273.286	273.622	273.957
480	274.293	274.628	274.963	275.298	275.633	275.968	276.303	276.638	276.972	277.307
490	277.641	277.975	278.309	278.643	278.977	279.311	279.644	279.978	280.311	280.644
500	280.978	281.311	281.643	281.976	282.309	282.641	282.974	283.306	283.638	283.971
510	284.303	284.634	284.966	285.298	285.629	285.961	286.292	286.623	286.954	287.285
520	287.616	287.947	288.277	288.608	288.938	289.268	289.599	289.929	290.258	290.588
530	290.918	291.247	291.577	291.906	292.235	292.565	292.894	293.222	293.551	293.880
540	294.208	294.537	294.865	295.193	295.521	295.849	296.177	296.505	296.832	297.160
550	297.487	297.814	298.142	298.469	298.795	299.122	299.449	299.775	300.102	300.428
560	300.754	301.080	301.406	301.732	302.058	302.384	302.709	303.035	303.360	303.685
570	304.010	304.335	304.660	304.985	305.309	305.634	305.958	306.282	306.606	306.930
580	307.254	307.578	307.902	308.225	308.549	308.872	309.195	309.518	309.841	310.164
590	310.487	310.810	311.132	311.454	311.777	312.099	312.421	312.743	313.065	313.386
600	313.708	314.029	314.351	314.672	314.993	315.314	315.635	315.956	316.277	316.597
610	316.918	317.238	317.558	317.878	318.198	318.518	318.838	319.157	319.477	319.796
620	320.116	320.435	320.754	321.073	321.391	321.710	322.029	322.347	322.666	322.984
630	323.302	323.620	323.938	324.256	324.573	324.891	325.208	325.526	325.843	326.160
640	326.477	326.794	327.110	327.427	327.744	328.060	328.376	328.692	329.008	329.324
650	329.640	329.956	330.271	330.587	330.902	331.217	331.533	331.848	332.162	332.477
660	332.792	333.106	333.421	333.735	334.049	334.363	334.677	334.991	335.305	335.619
670	335.932	336.246	336.559	336.872	337.185	337.498	337.811	338.123	338.436	338.748
680	339.061	339.373	339.685	339.997	340.309	340.621	340.932	341.244	341.555	341.867
690	342.178	342.489	342.800	343.111	343.422	343.732	344.043	344.353	344.663	344.973
700	345.284	345.593	345.903	346.213	346.522	346.832	347.141	347.451	347.760	348.069
710	348.378	348.686	348.995	349.303	349.612	349.920	350.228	350.536	350.844	351.152
720	351.460	351.768	352.075	352.382	352.690	352.997	353.304	353.611	353.918	354.224
730	354.531	354.837	355.144	355.450	355.756	356.062	356.368	356.674	356.979	357.285
740	357.590	357.896	358.201	358.506	358.811	359.116	359.420	359.725	360.029	360.334
750	360.638	360.942	361.246	361.550	361.854	362.158	362.461	362.765	363.068	363.371
760	363.674	363.977	364.280	364.583	364.886	365.188	365.491	365.793	366.095	366.397
770	366.699	367.001	367.303	367.604	367.906	368.207	368.508	368.810	369.111	369.412
780	369.712	370.013	370.314	370.614	370.914	371.215	371.515	371.815	372.115	372.414
790	372.714	373.013	373.313	373.612	373.911	374.210	374.509	374.808	375.107	375.406
800	375.704	376.002	376.301	376.599	376.897	377.195	377.493	377.790	378.088	378.385
810	378.683	378.980	379.277	379.574	379.871	380.167	380.464	380.761	381.057	381.353
820	381.650	381.946	382.242	382.537	382.833	383.129	383.424	383.720	384.015	384.310
830	384.605	384.900	385.195	385.489	385.784	386.078	386.373	386.667	386.961	387.255
840	387.549	387.843	388.136	388.430	388.723	389.016	389.310	389.603	389.896	390.188
850	390.481	-	-	-	-	-	-	-	-	-

The reference values have been calculated according to the International Temperature Scale ITS 90.
 (The reference values must be multiplied by the factor 5 or 10 for Pt500 or Pt1000 temperature sensors).

JUMO GmbH & Co. KG
Delivery address: Mackenrodtstraße 14,
36039 Fulda, Germany
Postal address: 36035 Fulda, Germany
Phone: +49 661 6003-0
Fax: +49 661 6003-607
e-mail: mail@jumo.net
Internet: www.jumo.net

JUMO Instrument Co. Ltd.
JUMO House
Temple Bank, Riverway
Harlow, Essex CM 20 2TT, UK
Phone: +44 1279 635533
Fax: +44 1279 635262
e-mail: sales@jumo.co.uk
Internet: www.jumo.co.uk

JUMO Process Control, Inc.
8 Technology Boulevard
Canastota, NY 13032, USA
Phone: 315-697-JUMO
1-800-554-JUMO
Fax: 315-697-5867
e-mail: info@jumo.us
Internet: www.jumo.us



Electrical Temperature Measurement

with thermocouples and resistance thermometers

Matthias Nau

Electrical temperature sensors have become indispensable components in modern automation, consumer goods and production technology. As a result of the rapid expansion of automation during recent years, they have become firmly established in industrial engineering.

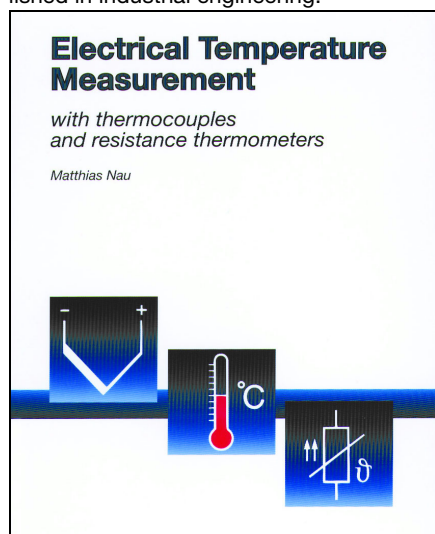

Fig. 25: Publication Electrical Temperature Measurement with thermocouples and resistance thermometers

In view of this large spectrum of available products for temperature measurement it is becoming ever more important for the user to select the one suitable for his application.

On 160 pages this publication deals with the theoretical fundamentals of electrical temperature measurement, the practical implementation of temperature sensors, their standardization, electrical connection, tolerances and types of construction.

In addition, it describes in detail the different fittings for electrical thermometers, their classification according to DIN standards, and the great variety of applications. An extensive section with tables for voltage and resistance series according to DIN and EN makes the book a valuable guide, both for the experienced practical engineer and the novice in the field of electrical temperature measurement.

You can order a copy by quoting Sales No. 90/00085081 or download from www.jumo.net.

Because of the high handling costs, schools, institutes and universities are asked to place a bulk order.

Error Analysis of a Temperature Measurement System

with worked examples

Gerd Scheller

This 44-page publication helps in the evaluation of measurement uncertainty, particularly through the worked examples in Chapter 3. Where problems arise, we are glad to discuss specific problems with our customers, and to give practical advice.

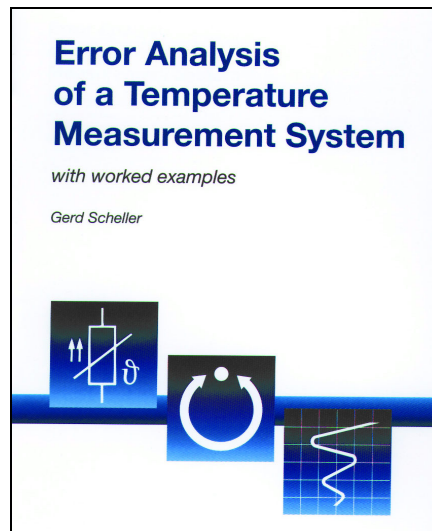

Fig. 26: Publication Error Analysis of a Temperature Measurement System, with worked examples

In order to be able to make comparable measurements, their quality must be expressed through specifying the measurement uncertainty. The ISO/BIPM "Guide to the Expression of Uncertainty in Measurement", published in 1993 and usually referred to as GUM, introduced a standardized method for the determination and definition of measurement uncertainty. This method was adopted by calibration laboratories around the world. However, the application requires a certain level of mathematical understanding. Further chapters present the topic of measurement uncertainty in a simplified and easily understandable fashion to all users of tempera-

ture measurement systems.

Errors in the installation of the temperature sensors and the connections to the evaluation electronics lead to increased errors in measurement. To these must be added the measurement uncertainty components of the sensor and the evaluation electronics. The explanation of the various components of measurement uncertainty is followed by some worked examples.

Knowledge of the measurement uncertainty components and their magnitudes enable the user to reduce individual components through the choice of equipment or altered installation conditions. The decisive factor is always, which level of measurement uncertainty is acceptable for a specific application. For instance, if a standard specifies tolerance limits for the deviation of a temperature from a nominal value, the measurement uncertainty of the method used for temperature measurement should not be larger than 1/3 of the tolerance.

You can order a copy by quoting Sales No. 90/00415704 or download from www.jumo.net

Because of the high handling costs, schools, institutes and universities are asked to place a bulk order.

JUMO GmbH & Co. KG

Delivery address: Mackenrodtstraße 14,
36039 Fulda, Germany
Postal address: 36035 Fulda, Germany
Phone: +49 661 6003-0
Fax: +49 661 6003-607
e-mail: mail@jumo.net
Internet: www.jumo.net

JUMO Instrument Co. Ltd.

JUMO House
Temple Bank, Riverway
Harlow, Essex CM 20 2TT, UK
Phone: +44 1279 635533
Fax: +44 1279 635262
e-mail: sales@jumo.co.uk
Internet: www.jumo.co.uk

JUMO Process Control, Inc.

8 Technology Boulevard
Canastota, NY 13032, USA
Phone: 315-697-JUMO
1-800-554-JUMO
Fax: 315-697-5867
e-mail: info@jumo.us
Internet: www.jumo.us



German Calibration Service (DKD) at JUMO

Certification laboratory for temperature

Raised quality expectations, improved measurement technology and, of course, quality assurance systems, such as ISO 9000, make increasing demands on the documentation of processes and the monitoring of measuring devices.

In addition, there are increasing calls from customers for high product quality standards. Particularly stringent demands arise from ISO 9000 and EN 45 000, whereby measurements must be traceable to national or international standards. This provides the legal basis for obliging suppliers and manufacturers (of products that are subject to processes where temperature is relevant) to check all testing devices which can affect the product quality, before use or at specified intervals. Generally, this is done by calibrating or adjusting with certified devices. Because of the high demand for calibrated instruments and the large number of instruments to be calibrated, the state laboratories have insufficient capacity. The industry has therefore established and supports special calibration laboratories which are linked to the German Calibration Service (DKD) and subordinate to the PTB (Physikalisch-Technische-Bundesanstalt) for all aspects of instrumentation.

The certification laboratory of the German Calibration Service at JUMO has carried out calibration certification for temperature since 1992. This service provides fast and economical certification for everyone.

DKD calibration certificates can be issued for resistance thermometers, thermocouples, direct-reading measuring systems, data loggers and temperature block calibrators as well as temperature probes with built-in transmitter, within the measuring range -80 to +1100°C.

The traceability of the reference standard is the central issue here. All DKD calibration certificates are recognized as documents of traceability, without any further specifications. The DKD certification laboratory at JUMO has the identification DKD-K-09501-04 and is accredited to EN ISO/IEC 17 025.

You can order a brochure free of charge, either by ordering Publication PR 90029 or download from www.jumo.net