

Temperature transmitter

Model : WTT-3100, WTT-3200

Spec. sheet no. **WD03-01**

Service intended

Temperature transmitters are designed to fit into a standard molded terminal heads used on RTD and thermocouple assemblies to provide a 4~20 mA transmission signals. It is a cost effective solution for all temperature measuring process. It is accurate, durable and reliable. Numerous configurations for measurement in many deferent mediums are offered. Generally the transmitter produces a linear 4~20 mA output carried on a two-wire system. The transmitter is supplied factory calibrated, but also has zero and span potentiometers for a field adjustment.



WTT-3100



WTT-3200

Standard features

Power supply

10~32 V DC

Permissible ambient temperature

-40 ~ 85 °C

Input

Thermocouple : K, E, N, T, J, B, R, S
RTD : Pt 100 Ω at 0 °C

Humidity limits

10~90% Relative humidity

Output

4~20 mA with HART Protocol
(HART Version : Revision 7 (Generic))
4~20 mA

Programmable function setting

- Input signal type
- Measuring range
- Burnout Low/High setting

Accuracy

See table "Sensor type, range and accuracy"

WISE[®]

Main order

1. Base model

WTT-3100 Head mounted type (Hockey puck)

2. Type

- A** 4~20 mA with HART protocol
- B** 4~20 mA

3. Input signal

- PT** Pt 100 Ω (RTD)
 - TR** R type (Thermocouple)
 - TK** K type (Thermocouple)
 - TE** E type (Thermocouple)
 - TJ** J type (Thermocouple)
 - TT** T type (Thermocouple)
 - TB** B type (Thermocouple)
 - TS** S type (Thermocouple)
 - TN** N type (Thermocouple)
 - mV** mV Input (Signals)
- * See table "Sensor type, range and accuracy"

4. Measuring range (°C)

- XX** Other calibration ranges available on request

Ordering information

1. Base model

WTT-3200 Din rail type

2. Type

- A** 4~20 mA with HART protocol

3. Input signal

- PT** Pt 100 Ω (RTD)
 - TR** R type (Thermocouple)
 - TK** K type (Thermocouple)
 - TE** E type (Thermocouple)
 - TJ** J type (Thermocouple)
 - TT** T type (Thermocouple)
 - TB** B type (Thermocouple)
 - TS** S type (Thermocouple)
 - TN** N type (Thermocouple)
 - mV** mV Input (Signals)
- * See table "Sensor type, range and accuracy"

4. Measuring range (°C)

- XX** Other calibration ranges available on request

Sample ordering code

1	2	3	4
WTT-3100	A	PT	XX

1-1. WTT-3100 Head mounted type (Hockey puck)_w/HART Protocol

Sensor type, range, accuracy

Resistance temperature detector (RTD)

Input	Measuring range (°C)	Recommended Temperature range (°C)	Min. measured span (°C)	Accuracy
Pt100	-200 ~ 850	-200 ~ 850	10	±0.15 °C or Span *0.1 %

Thermocouple elements (T/C)

Input	Measuring range (°C)	Recommended Temperature range (°C)	Min. measured span (°C)	Accuracy
Type B	150 ~ 1820	600 ~ 1820	100	±1.0 °C or Span *0.1 %
Type R	0 ~ 1768	0 ~ 1768	100	±0.8 °C or Span *0.1 %
Type S	0 ~ 1768	0 ~ 1768	100	±0.8 °C or Span *0.1 %
Type K	-200 ~ 1372	-200 ~ 1372	25	±0.4 °C or Span *0.1 %
Type E	-200 ~ 1000	-200 ~ 1000	25	
Type N	-200 ~ 1300	-200 ~ 1300	25	
Type J	-210 ~ 1200	-210 ~ 1200	25	
Type T	-200 ~ 400	-200 ~ 400	25	

mV sensor

Input	Measuring range (°C)	Recommended Temperature range (°C)	Min. measured span (°C)	Accuracy
mV	-120 ~ 120 mV	-120 ~ 120 mV	10 mV	±10 µV or Span *0.1 %
	-1000 ~ 1000 mV	-1000 ~ 1000 mV	50 mV	±100 µV or Span *0.1 %

* **Note.** The transmitter must be used in conjunction with a WISE sensor.

1-2. WTT-3100 Head mounted type (Hockey puck)

Sensor type, range, accuracy

Resistance temperature detector (RTD)

Input	Measuring range (°C)	Recommended Temperature range (°C)	Accuracy
Pt100	-200 ~ 850	-200 ~ 850	±0.1 °C

Thermocouple elements (T/C)

Input	Measuring range (°C)	Recommended Temperature range (°C)	Accuracy
Type B	150 ~ 1820	600 ~ 1820	±1.0 °C
Type R	0 ~ 1768	0 ~ 1760	
Type S	0 ~ 1768	0 ~ 1760	
Type K	-200 ~ 1372	-200 ~ 1372	±0.5 °C
Type E	-200 ~ 1000	-200 ~ 1000	
Type N	-200 ~ 1300	-200 ~ 1300	
Type J	-210 ~ 1200	-210 ~ 1200	
Type T	-200 ~ 400	-200 ~ 400	

mV sensor

Input	Measuring range (°C)	Recommended Temperature range (°C)	Accuracy
mV	-120 ~ 120 mV	-120 ~ 120 mV	±10 µV
	-1000 ~ 1000 mV	-1000 ~ 1000 mV	±100 µV

* **Note.** The transmitter must be used in conjunction with a WISE sensor.

2. WTT-3200 Din rail type_w/HART Protocol

Sensor type, range, accuracy

Resistance temperature detector (RTD)

Input	Measuring range (°C)	Recommended Temperature range (°C)	Min. measured span (°C)	Accuracy
Pt100	-200 ~ 850	-200 ~ 850	10	±0.15 °C or Span *0.2 %

Thermocouple elements (T/C)

Input	Measuring range (°C)	Recommended Temperature range (°C)	Min. measured span (°C)	Accuracy
Type B	150 ~ 1820	600 ~ 1820	100	±1.0 °C or Span *0.2 %
Type R	0 ~ 1768	0 ~ 1760	100	±0.8 °C or Span *0.2 %
Type S	0 ~ 1768	0 ~ 1760	100	±0.8 °C or Span *0.2 %
Type K	-200 ~ 1372	-200 ~ 1372	25	±0.4 °C or Span *0.2 %
Type E	-200 ~ 1000	-200 ~ 1000	25	
Type N	-200 ~ 1300	-200 ~ 1300	25	
Type J	-210 ~ 1200	-210 ~ 1200	25	
Type T	-200 ~ 400	-200 ~ 400	25	

mV sensor

Input	Measuring range (°C)	Recommended Temperature range (°C)	Min. measured span (°C)	Accuracy
mV	-120 ~ 120 mV	-120 ~ 120 mV	10 mV	±10 µV or Span *0.2 %
	-1000 ~ 1000 mV	-1000 ~ 1000 mV	50 mV	±100 µV or Span *0.2 %

Input resistor : 250 Ω (External)

Dimension

WTT-3100 Head mounted type (Hockey puck)

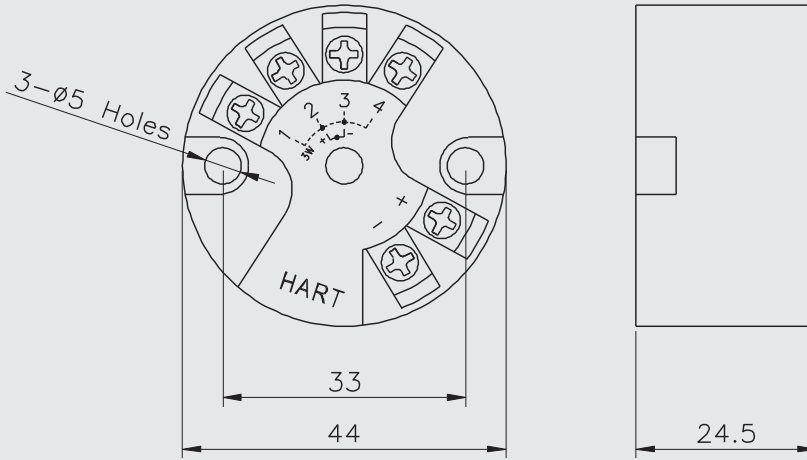

WTT-3200 (Din rail type)

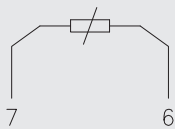
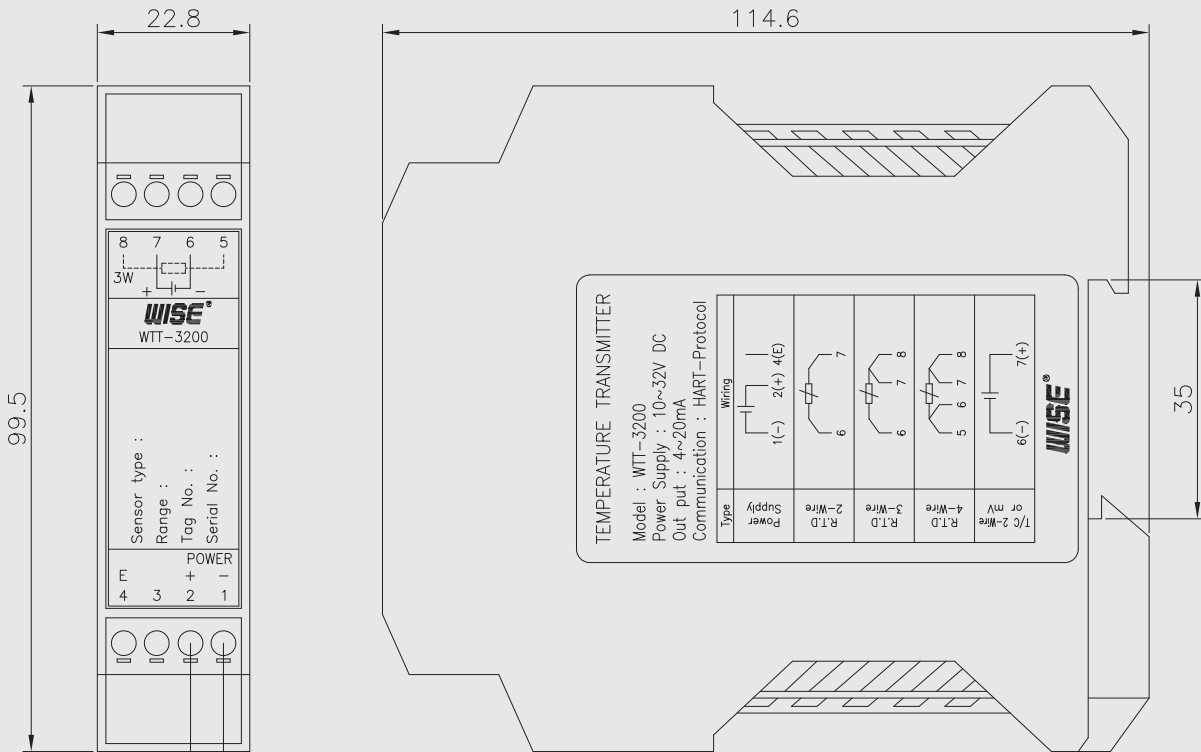

RTD (2-Wire)
& Ω

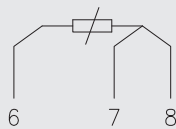

RTD (3-Wire)
& Ω

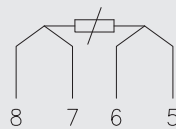

RTD (4-Wire)
& Ω

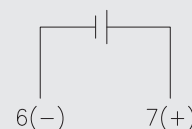

TC (2-Wire)
& mV

Wiring diagram

WTT-3100 Head mounted type (Hockey puck)

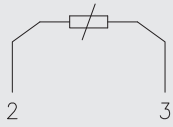
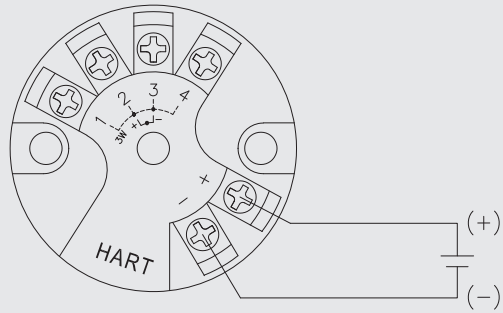

RTD (2-Wire)
& Ω

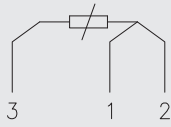

RTD (3-Wire)
& Ω

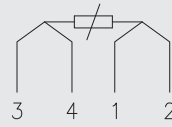

RTD (4-Wire)
& Ω

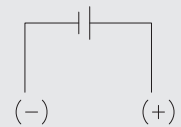

TC (2-Wire)
& mV

WTT-3200 Din rail type

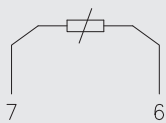
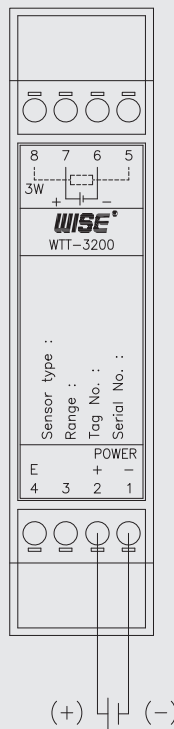

RTD (2-Wire)
& Ω

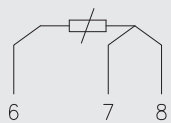

RTD (3-Wire)
& Ω

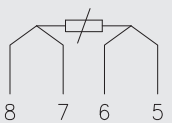

RTD (4-Wire)
& Ω

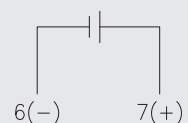

TC (2-Wire)
& mV

Transmitter failure (NAMUR NE43)

Namur NE43 specifies a sensor fault is signaled by extending the range of the 4-20 mA signal. When the loop current is below 3.6 mA or above 21 mA this is interpreted as a sensor fault. In order to avoid false alarms, the signal shall be present for at least 4 seconds before it is interpreted as sensor fault.

Transmitter failure can be caused because of sensor or converter failure. When these errors occur, smart instruments will adjust the output signal to 3.6 mA or 21.0 mA, based on how the user set the fail-safe mode. Now a days there are many transmitters and equipments that are set fail safe mode according to NAMUR NE43 standard and also let you allow to choose between down scale and upscale failure mode.

There is only 0.2 mA gap between the medium saturation area's 3.6 mA downscale signal rate and the higher saturation area's 3.8 mA start value as a 2-wire transmitter needs the current below 3.6 mA for its proper operation. Many suppliers also have equipment that uses less than 3.6 mA.

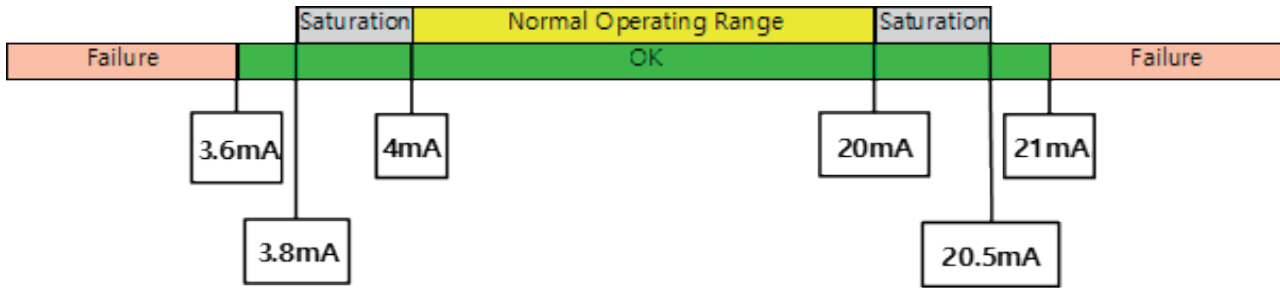

Level	NAMUR NE43		WTT-3100, WTT-3200	
	Saturation	Alarm	Saturation	Alarm
Low	3.8 mA (3.7~3.9)	≤ 3.6 mA (3.5~3.75)	3.9 mA	≤ 3.75 mA
High	20.5 mA (20.5~20.9)	≥ 21 mA (21~23)	21 mA	≥ 22 mA

* Error signal (NAMUR NE43) : High/Low (Adjustable)

* Note : The standard setting of failure alarm is High mode