

Multi point thermocouple and resistance temperature detector

Model : R500 series

Spec. sheet no. RD05-01



Service intended

This type of detector is designed to be used in a situation where the user wants to measure the distributed temperature of a reactor or a container. It can measure horizontally distributed temperature and also can measure the temperature in each depth of the container or the reactor. It is also designed to consider the size of nozzle, installation space and requirement and convenience of repairing and replacing. WISE Control Inc. can manufacture any types of multi point temperature sensors, and upon request of the customer, we can employ the requested material of protection tube, the material of sheath, size, measuring points and the method of attaching the sensor.

Especially, we can provide the temperature sensors without protection tube in a high pressure line by employing our own safety measures. The temperature sensors for junction box to connect the terminal can be manufactured in a both non-explosion proof and explosion proof type.



Standard features

Element

Thermocouple : K, E, J, T, N
R.T.D. : Pt 100 Ω at 0 °C

Number of measuring temperature point

Possible to manufacture according to customer's required number of points within the allowed range of nozzle bore

Junction box material

Aluminium (Standard)
Stainless steel

Tolerances on temperature reading

■ Thermocouple
Class 1, Class 2 (DIN/IEC584-2, BS/EN60584-2, JIS C1602)
Special, Standard (ASTM E230, E988, ISA-MC96.1)

Sheath outer diameter

■ Thermocouple
1.0, 1.6, 2.3, 3.2, 4.8, 6.4, 8.0, 9.5 and 12.7 mm
* Double element is not available for 1.0 mm sheath outer diameter

■ R.T.D.

Class A : $\pm (0.15 + 0.002 | t |)$
Class B : $\pm (0.3 + 0.005 | t |)$

■ R.T.D.

3.2, 4.8, 6.4 and 8.0 mm

Degree of protection

EN60529/IEC529/IP65

WISE[®]

1. Base model

- R511** Thermocouple single element
- R512** Thermocouple double element
- R521** RTD single element
- R522** RTD double element

2. Head and stem type

- 0** General and protection tube
- 1** General and non - protection tube
- 2** Explosion proof and protection tube
- 3** Explosion proof and non - protection tube
- 9** Other

3. Head extension type and sealing location

- 0** Nipple and head
- 1** Nipple and flange
- 2** Union - Nipple and head
- 3** Union - Nipple and flange

4. Element (Tolerance)

- | | |
|-----------------------|-----------------------|
| K K (0.75) | 1 K (0.4) |
| J J (0.75) | 2 J (0.4) |
| T T (0.75) | 3 T (0.4) |
| N N (0.75) | 4 E (0.4) |
| E E (0.5) | 5 N (0.4) |
| Q Pt 100 Ω (B) | 9 Pt 100 Ω (A) |
| Z Other | |

5. Number of measuring temperature point

- | | |
|------------|----------------|
| A 2 | J 10 |
| B 3 | K 11 |
| C 4 | L 12 |
| D 5 | M 13 |
| E 6 | N 14 |
| F 7 | P 15 |
| G 8 | Z Other |
| H 9 | |

6. Sheath outer diameter (mm)

- | | |
|--------------|-------------------------|
| 0 1.6 | 5 1.6 / weld PAD |
| 1 3.2 | 6 3.2 / weld PAD |
| 2 4.8 | 7 4.8 / weld PAD |
| 3 6.4 | 8 6.4 / weld PAD |
| 4 8.0 | 9 8.0 / weld PAD |

7. Sheath material

- 1** 316SS
- 2** Inconel
- 3** 310SS
- 4** 446SS
- 5** 347SS
- 6** 321SS
- 7** 316L SS
- 9** Other

8. Protecting tube material

- 1** 316SS
- 2** Inconel
- 3** 310SS
- 4** 446SS
- 5** 347SS
- 6** 321SS
- 7** Other

9. Process connection

- XX** Refer to connection table (12th and 13th character)

10. Insert length

- X** Refer to insert length table (14th character)

11. Option

- 0** None
- 1** Accessories

Sample ordering code

1	2	3	4	5	6	7	8	9	10	11
R511	0	3	K	J	3	1	1	XX	X	0



© WISE Control Inc. All rights reserved. ALL PRODUCT, PRODUCT SPECIFICATIONS AND DATA ARE SUBJECT TO CHANGE WITHOUT NOTICE TO IMPROVE RELIABILITY, FUNCTION OR DESIGN OR OTHERWISE.

Mounting, connection type and insert length table - 12th thru 14th characters

12 th character		13 th character		14 th character	
Code	Connection size	Code	Connection type	Code	Insertion length (m)
0	1"	A	NPT	A	2
1	1¼"	B	PT	B	3
2	1½"	C	B16.5 Class 150 RF	C	4
3	2"	D	B16.5 Class 150 FF	D	5
4	2½"	E	B16.5 Class 300 RF	E	6
5	3"	F	B16.5 Class 300 FF	F	7
6	4"	G	B16.5 Class 600 RF	G	8
7	6"	H	B16.5 Class 600 FF	H	9
9	Other	I	B16.5 Class 600 RTJ	J	10
		J	B16.5 Class 900 RF	K	15
		K	B16.5 Class 900 FF	L	20
		L	B16.5 Class 1500 RF	M	25
		M	B16.5 Class 1500 FF	N	30
		N	B16.5 Class 1500 RTJ	P	35
		P	B16.5 Class 2500 RF	Q	40
		Q	B16.5 Class 2500 FF	R	45
		R	B16.5 Class 2500 RTJ	S	50
		S	JIS 10K RF	Z	Other
		T	JIS 10K FF		
		U	JIS 20K RF		
		V	JIS 20K FF		
		Z	Other		

■14th characters note : Please choose the longest among measuring points.

R500 : Standard product drawing (1/2)

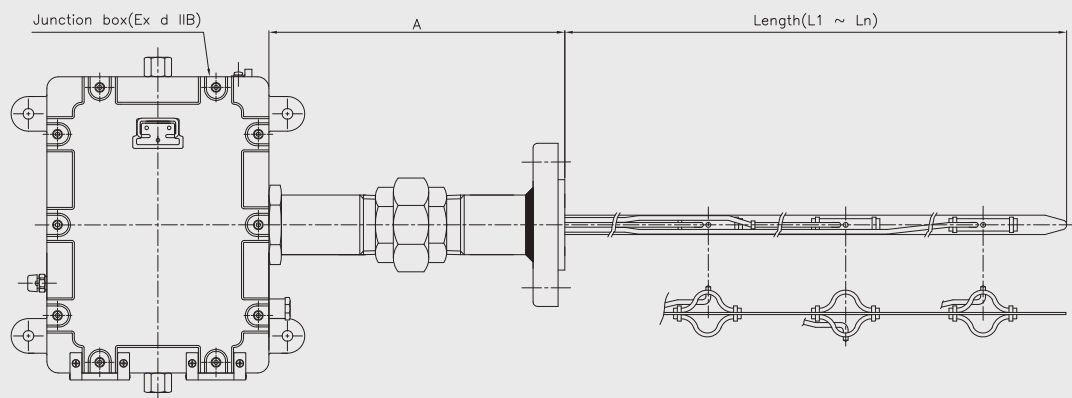
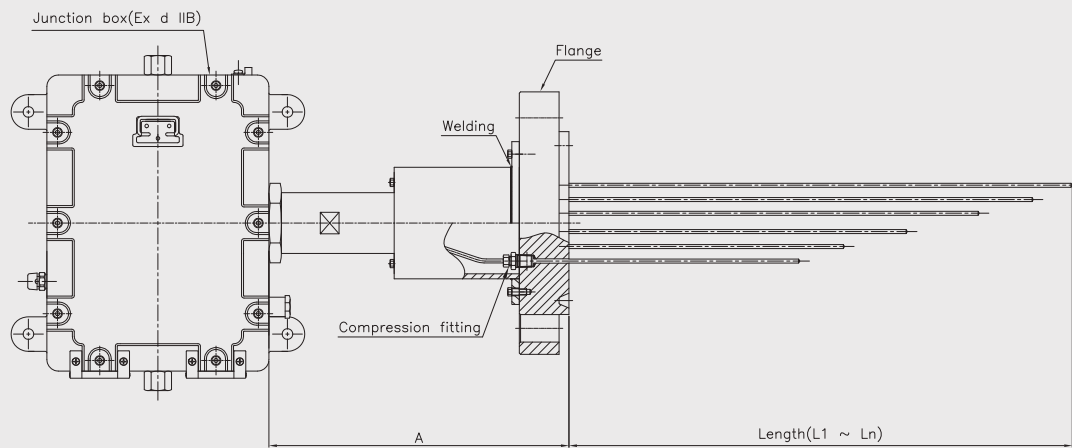
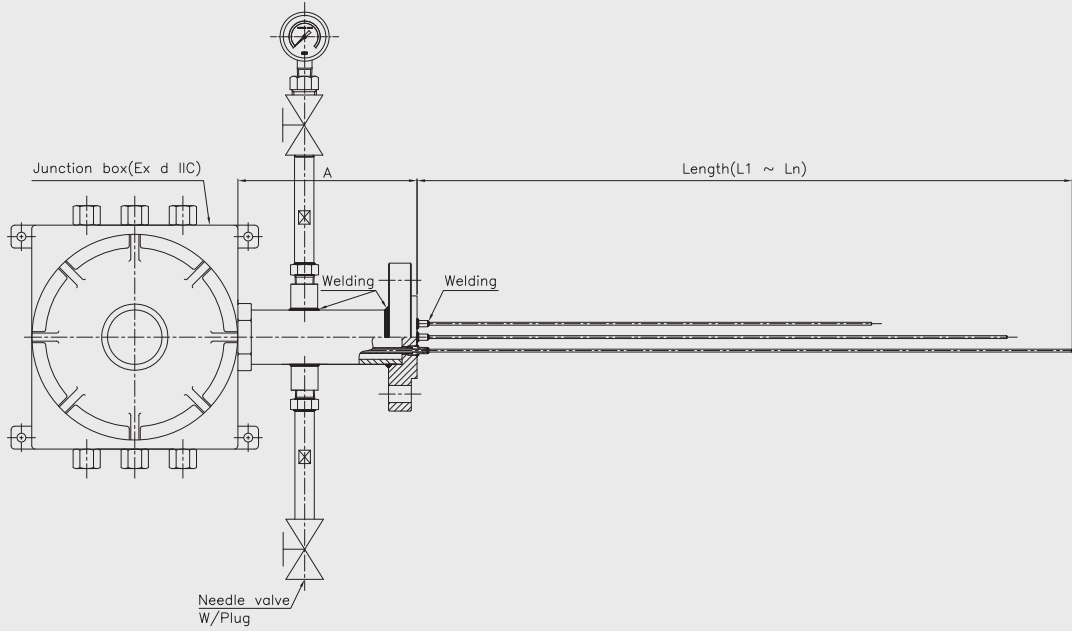

R500 : Standard product drawing (2/2)

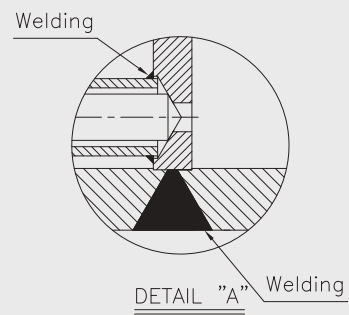
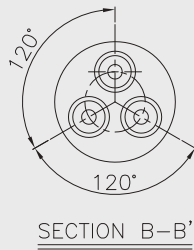
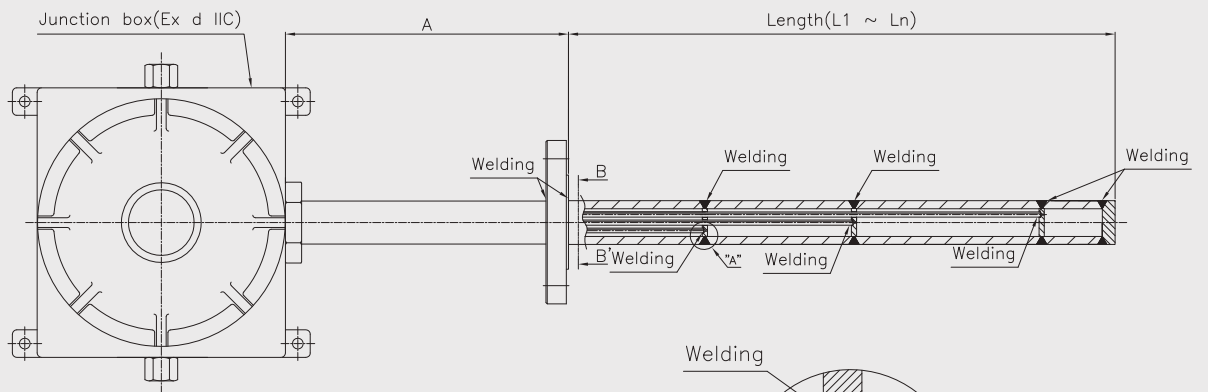
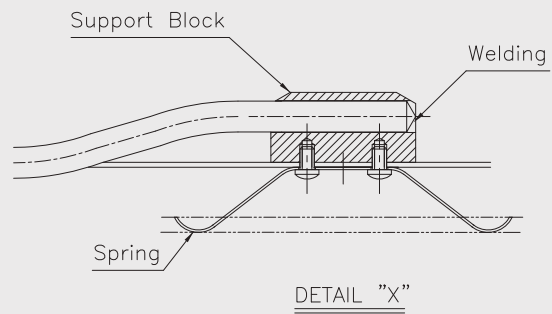
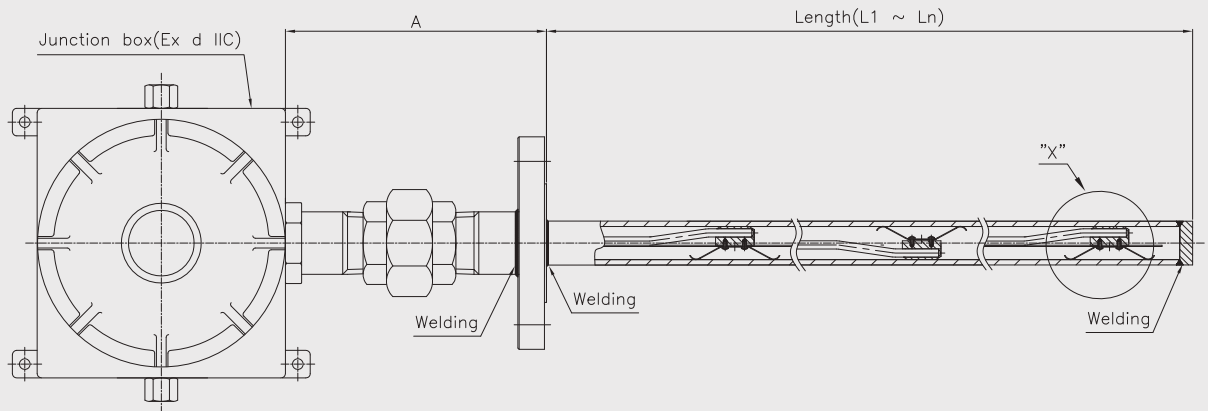

Large empty rectangular box for memo content.