

Level switch for magnetic type level gauge

Model : LS30 series

Spec. sheet no. LD03-01

Service intended

The level switch is an instrument that can notice the water level inside the tank by activating by activating the contact point of the reed switch inside the switch by the magnet of the float when the float inside the level gauge reaches the attached level switch.

It is used in the process of performing alarm and control functions when supplying or draining water.

Standard features

- Switch type : Reed switch
- Switch form : SPDT
- Max. switching voltage / Current : 230VAC / 24 VDC / 0.5A
- Material : Head - Aluminium / Body - Aluminium
- LS31 : Weather proof
- LS32 : Ex-proof (KCs, Ex db IIC T4, IP65)



Main order

Ordering information

1. Base model

LS31 Weather proof type

LS32 Ex-proof type (KCs, Ex db IIC T4, IP65)

2. Conduit connection (Ex-proof adapter should be applied to Ex-proof.)

- 1 ½" PF(F) (S.T.D)
- 3 ½" NPT(F) w / Adapter
- 4 ¾" PF(F) w / Adapter
- 6 ¾" NPT(F) w / Adapter
- 8 M20X1.5P w / Adapter
- 9 Other

3. Accessory

- B** Special bracket
(When the set point is within 20 mm of the C to C connection)
- N** None

Sample ordering code

1	2	3
LS32	1	N

LS30 series dimension

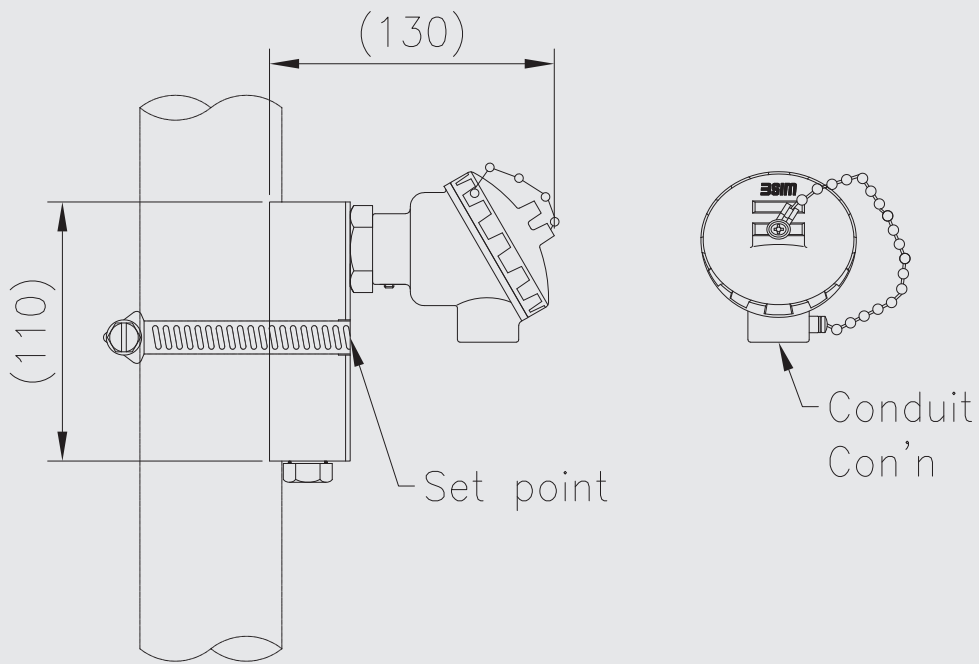

LS31 – Weather proof

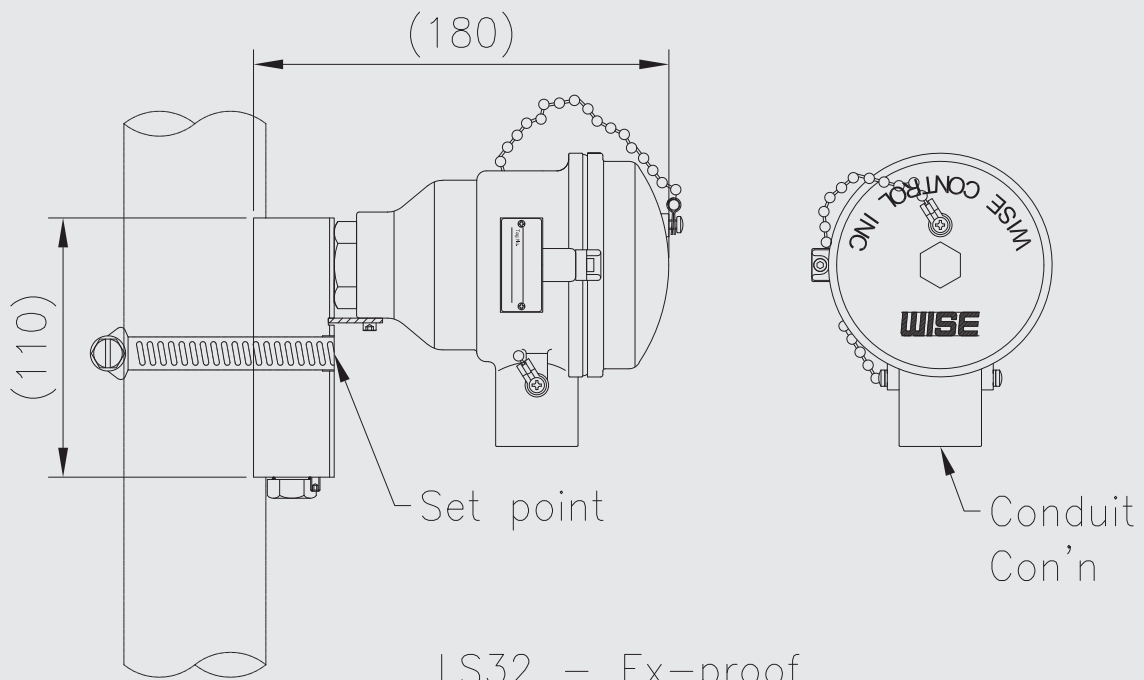

LS32 – Ex-proof