

Averaging pitot tube

Model : F760

Spec. sheet no. FD07-03

Description

Averaging pitot tube is an energy saving device used to measuring the flow of liquids, gases and steam in pipes, stacks and rectangular ducts.

It provides high, long term stability with low permanent pressure loss.

Examples of their applications are precise volumetric flow measurement in batch processes, continuous measurement of liquid ingredients in the process industry, fuel, air, steam and gases as primary energy source as well as in control functions requiring a high degree of stability and repeatability.

Advantages

- Dual averaging for better accuracy
- Short upstream and downstream straight pipe lengths
- Long term accuracy unaffected by wear

EAC



Specification

Measuring fluid

Liquid, Gas, Steam and etc.

Max. working temperature

600 °C

Material

304SS, 316SS, 316L SS and Monel
Special materials are available

Accuracy

±1 % of actual flow rate

Pipe size

50~1000 mm
2~40"

Max. working pressure

900Lb

Rangeability

5:1

WISE[®]

1. Base model

F760 Averaging pitot tube

2. Line size

A01	½"	J01	15A
A02	¾"	J02	20A
A03	1"	J03	25A
A04	1½"	J04	40A
A05	2"	J05	50A
A06	3"	J06	80A
A07	4"	J07	100A
A08	6"	J08	150A
A09	8"	J09	200A
A10	10"	J10	250A
A11	12"	J11	300A
A12	14"	J12	350A
A13	16"	J13	400A
A14	18"	J14	450A
A15	20"	J15	500A
A16	24"	J16	600A
ZZZ	Other		

3. Mounting connection

A1	2" ANSI 150Lb RF
A2	2" ANSI 300Lb RF
A3	2½" ANSI 150Lb RF
A4	2½" ANSI 300Lb RF
J1	50A JIS 10K RF
J2	50A JIS 16K RF
J3	50A JIS 20K RF
J4	65A JIS 10K RF
J5	65A JIS 16K RF
J6	65A JIS 20K RF
ZZ	Other

4. Support type

1	Single
2	Double

5. Sensor material

4S	304SS
6S	316SS
6L	316L SS
ZZ	Other

6. Tap valve

1	½" NPT, Needle valve
2	½" NPT, Ball valve
O	Other
N	None

7. Option

C	Calibration test
O	Other
N	None

Sample ordering code

1	2	3	4	5	6	7
F760	A01	A1	1	4S	1	C



© WISE Control Inc. All rights reserved. ALL PRODUCT, PRODUCT SPECIFICATIONS AND DATA ARE SUBJECT TO CHANGE WITHOUT NOTICE TO IMPROVE RELIABILITY, FUNCTION OR DESIGN OR OTHERWISE.

Measurement principal of pitot tube

Averaging pitot tubes are generally used for large line sizes or ducts where other primary devices become relatively expensive.

Averaging pitot tube comprises of following components :

- Outer impact tube
- Internal averaging tube
- Low pressure chamber
- Head

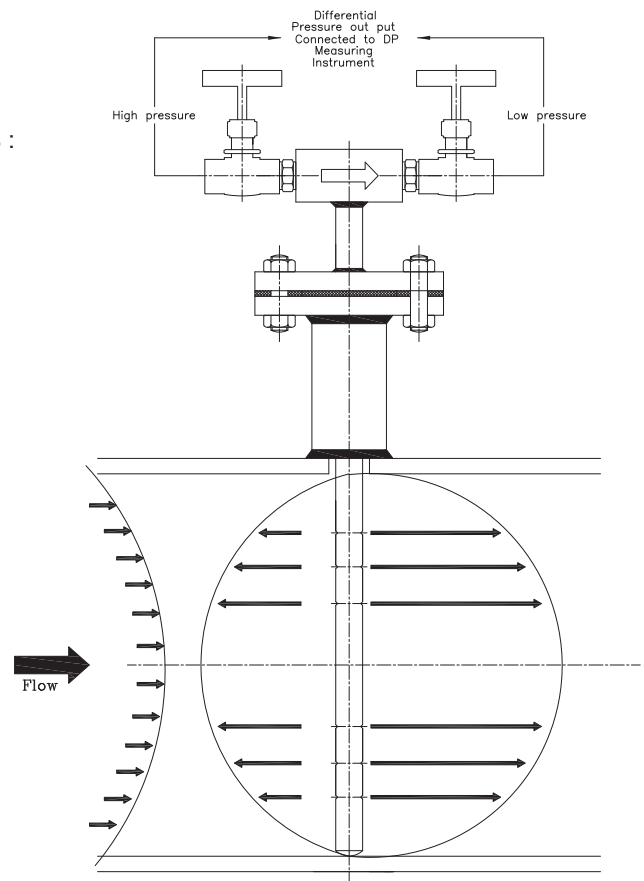

The outer impact tube has a number of pressure sensing holes facing upstream which are positioned at equal annular points in accordance with a loglinear distribution.

The total pressure developed at each upstream hole by the impact of the flowing medium are firstly averaged within the outer impact tube and then to a second order (and more accurately) averaged within the internal averaging tube.

This pressure is represented at the head as the high pressure component of the DP output.

The low pressure component is generated from a single sensing hole located on the downstream side of the outer impact tube.

Stable flow coefficient which is the result of typical diamond shape, makes it a reliable flow measuring primary flow element.

Simple and inexpensive, long term accuracy within acceptable limits over wide range of flow, low permanent pressure loss and minimum operating cost makes it ideal choice of any design engineer.

Orientation in pipe

1. Horizontal pipe mounting - Gas

To ensure the instrument lines contain only gas, install APT with the instrument connections above the centre line of the pipe, at least 5° above the horizontal

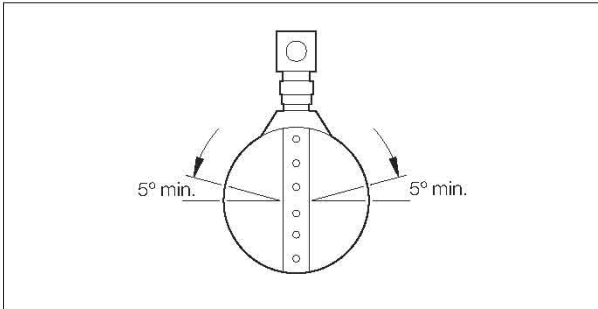

<Horizontal pipe mounting - Gas>

2. Horizontal pipe mounting - Liquids

To ensure the instrument lines contain only the process liquid, install APT with the instrument connections below the centre line of the pipe, at least 5° below the horizontal

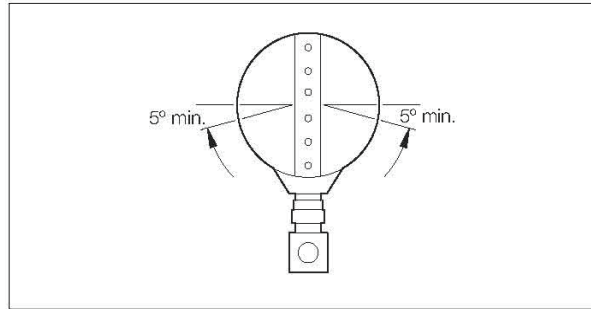

<Horizontal pipe mounting - Liquid>

3. Horizontal pipe mounting - Steam

To ensure the instrument lines contain only steam, install APT with the instrument connections at or below the centre line of the pipe

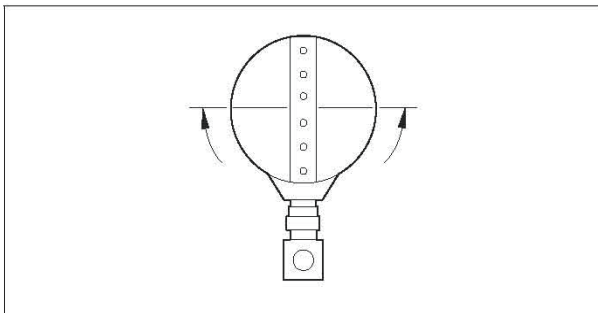

<Horizontal pipe mounting - Steam>

4. Vertical pipe mounting - All applications

Any lateral - mounting angle is suitable

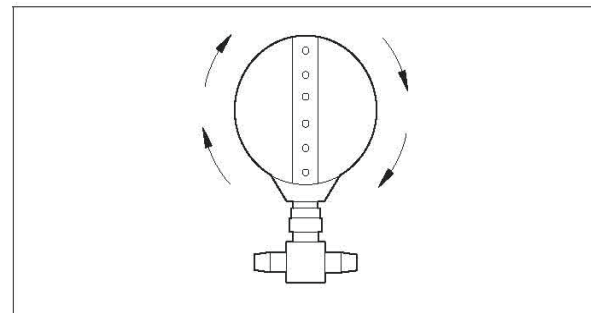

<Vertical pipe mounting - All applications>

Recommended straight run

In common with other differential pressure primary flow elements, averaging pitot tubes require a well developed flow profile. Disturbances created by various pipe configurations can reduce measurement accuracy. Recommended upstream and downstream straight pipe lengths are shown below, in terms of multiples of the pipe diameter.

Averaging pitot tubes installed with shorter pipe lengths can still provide an repeatable flow measurement.

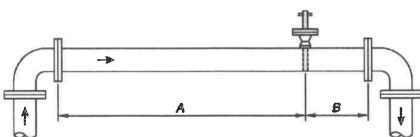
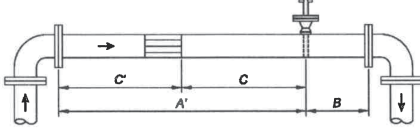
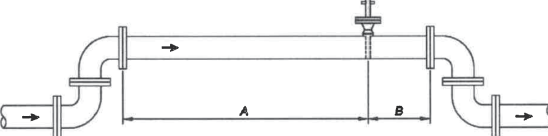
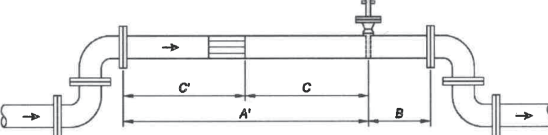
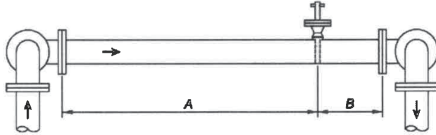
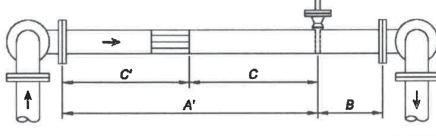
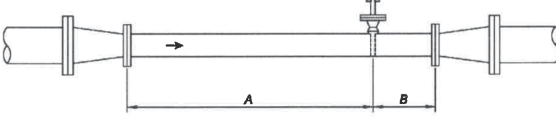
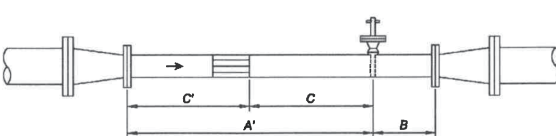
Minimum Length of a Straight Run	Upstream					Down stream
	Without vanes		With vanes			
	In plane	Out of plane	A'	C	C'	B
	A	A				
 	7	9				3
			6	3	3	
 	9	14				3
			8	4	4	
 	19	24				4
			9	4	5	
 	8	8				3
			8	4	4	

Large empty rectangular box for notes or memos.