

JUMO Wtrans T01/T02

RTD Temperature Probe with Wireless Data Transmission

FC c **UL**[®] US



Operating Manual



90293000T90Z004K000

V3.00/EN/00489934/2025-07-29

Table of contents

1	Introduction	5
1.1	Safety information	5
1.2	Description	6
1.3	Block diagram	6
1.4	Dimensions	7
1.5	Declaration of conformity	7
2	Identifying the device version	9
2.1	Type specifications	9
2.2	Scope of delivery	10
2.3	Accessories	10
2.4	Order details	12
3	Preparing the transmitter	19
3.1	Inserting/changing the battery	19
3.2	Safety information concerning lithium batteries	21
3.3	Disposal of lithium batteries	21
3.4	Battery operating life	22
3.5	Attaching the color coding of a transmitter	23
4	Transmission range	25
4.1	General information about wireless transmission	25
4.2	Possible impairment of radio transmission	26
5	Mounting	29
5.1	Information about fastening, securing and arrangement	29
5.2	Wall holder dimensions	30
5.3	Installing the holder for wall mounting and transmitter	31
6	Connection diagram	33
6.1	Machine connector M12 × 1, 4-pin according to IEC 60947-5-2	33
7	Setup program	35
7.1	General information about the setup program	35
7.2	Hardware and software requirements	36
7.3	Establishing the connection between PC and transmitter	37
7.4	Transmitter configuration	39
7.4.1	Establishing the communication	39
7.4.2	Reading the current transmitter parameters	40
7.4.3	Editing transmitter parameters	40
7.4.4	Transmitting new parameters to the transmitter	40
7.5	Parameter overview	41

Table of contents

8	Technical data43
9	China RoHS47

1.1 Safety information

General

This manual contains information that must be observed in the interest of your own safety and to avoid material damage. This information is supported by symbols which are used in this manual as indicated.

Please read this manual before starting up the device. Store this manual in a place that is accessible to all users at all times.

If difficulties occur during startup, please do not intervene in any way that could jeopardize your warranty rights!

Warning symbols



CAUTION!

This symbol in connection with the signal word indicates that **material damage or data loss** will occur if the respective precautionary measures are not taken.



READ THE DOCUMENTATION!

This symbol, which is attached to the device, indicates that the associated **documentation for the device** must be **observed**. This is necessary to identify the nature of the potential hazard, and to take measures to prevent it.

Note symbols



NOTE!

This symbol refers to **important information** about the product, its handling, or additional benefits.



REFERENCE!

This symbol refers to **additional information** in other sections, chapters, or other manuals.

1 Introduction

1.2 Description

The Wtrans T01/T02 is used in connection with a Wtrans receiver for stationary or mobile detection of temperatures within the operating range of -30 to +260 °C or -200 to +600 °C. This measured temperature value is transmitted wirelessly to the receiver of the Wtrans measuring system; here it is displayed and available digitally at the RS485 interface as well as an analog output. One receiver variant can signal various alarms on two relay outputs.

The transmission electronics of the RTD temperature probe are placed in the case so that they are vibration-proof; the case is oil-resistant and acid-proof. The ambient temperature of the case may either be from -30 to +85 °C or -25 to +125 °C. The protection type is IP67. A durable lithium battery with 3.6 V is used for voltage supply.

The radio frequencies of the Wtrans measuring system (868.4 MHz or 915 MHz) are largely impervious to external interferences and allow transmission even in a rough industrial environment. When using the antenna holder for wall mounting with the 3 m antenna cable for the receiver, the open air range is 300 m.

The stainless steel protection tube with the Pt1000 temperature sensor according to DIN EN 60751, class A in a 3-wire circuit is available with a flat, oblique, or centered probe tip. The insertion length extends from 30 to 10000 mm. Variants are available with an extension tube or an M12 × 1 plug connection to connect Pt1000 RTD temperature probes.

A setup program is available as an accessory for easy configuration and parameterization of the Wtrans measuring system on the PC. The OnlineChart function can be used optionally to record the measured values on the PC.

1.3 Block diagram

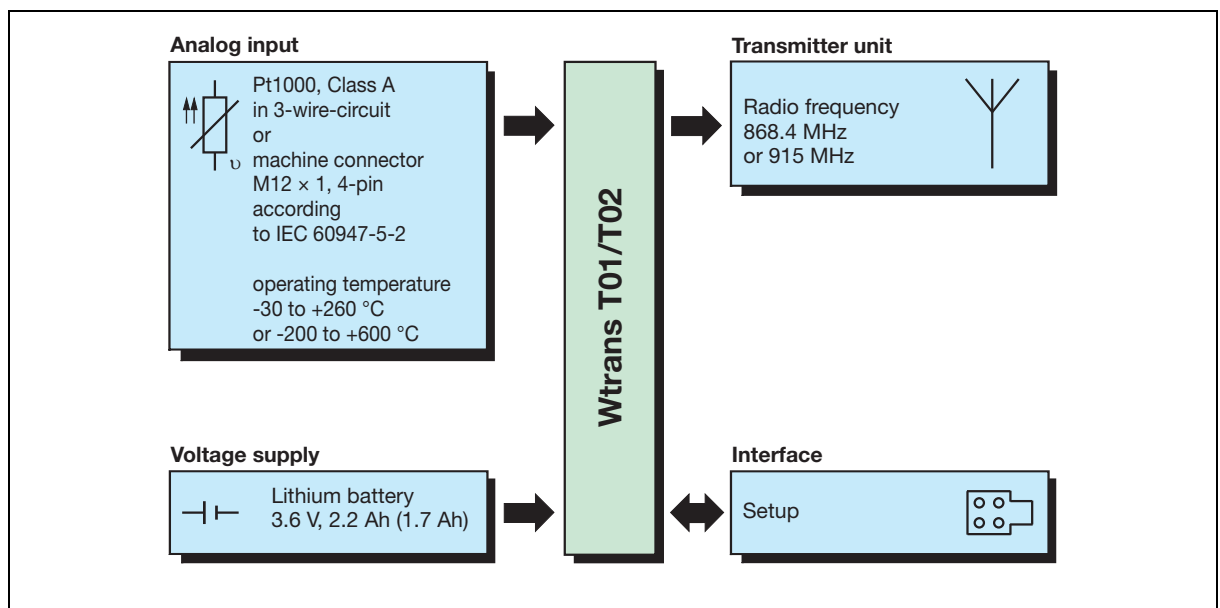

Fig. 1-1 Block diagram of the transmitter

1.4 Dimensions

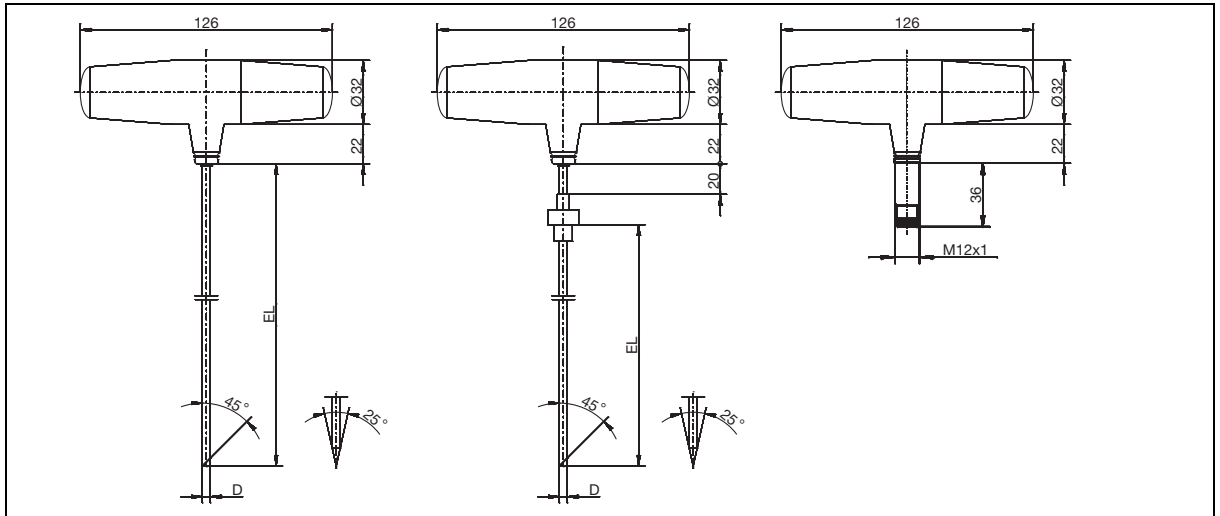

Fig. 1-2 Basic types 902930/10, 902930/12, 902930/20 and 902930/22 (left)
Basic types 902930/10, 902930/12, 902930/20 and 902930/22 with process connection (center)
Basic types 902930/50 and 902930/60 with M12 plug connection (right)

1.5 Declaration of conformity



NOTE!

Hereby JUMO GmbH & Co. KG declares that the radio equipment type Wtrans T01/T02 is in compliance with Directive 2014/53/EU. The full text of the EU declaration of conformity is available at the following Internet address: qr-902930-en.jumo.info



qr-902930-en.jumo.info

1 Introduction

2 Identifying the device version

2.1 Type specifications

Position

A laser has been used to label the type specifications on the protection tube/housing.

Contents

The specifications contain important information. This includes:

Description	Example
Fabrication number (F-no.)	0070033801207430006
Transmitter detection (transmitter ID)	12345
Radio frequency	868.4 or 915

F-no.

The fabrication number is used by the manufacturer to identify the device.

The fabrication number (F-no.) indicates the production date (year/week).

The figures used for this are 12, 13, 14, 15.

Example: F-no. = 00700338012**0743**0006

The device was produced in the 43rd calendar week of 2007.

Transmitter ID

The transmitter ID is factory set. It must be entered and activated on the receiver to establish communication between the transmitter and receiver. The transmitter ID can be changed to customer specific requirements using the setup program.

Radio frequency

The radio frequency identifies the frequency used by the device for transmission. In the 868 MHz band, the transmission is carried out at 868.4 MHz. In the 915 MHz band, 10 frequencies can be configured.

2 Identifying the device version

2.2 Scope of delivery

1 device in the ordered version
1 preconfigured 3.6 V, 2.2 Ah lithium battery (ambient temperature of housing: -30 to +85 °C) or
1 preconfigured 3.6 V, 1.7 Ah lithium battery (ambient temperature of housing: -25 to +125 °C)
4 color rings made of silicone (white, green, red, blue) for visual transmitter identification
1 operating manual

2.3 Accessories

The following articles must be ordered separately and with costs:

Description	Part no.
1 setup program on CD-ROM, multilingual	00488887
1 setup program including OnlineChart on CD-ROM, multilingual	00549067
1 OnlineChart activation	00549188
1 preset lithium battery 3.6 V, 2.2 Ah (ambient temperature of housing: -30 to +85 °C)	00525539
1 preset lithium battery 3.6 V, 1.7 Ah (ambient temperature of housing: -25 to +125 °C)	00534690
1 housing seal set with axial gaskets made of EPDM (ethylene propylene diene rubber) (contents: 3 pieces, white) and radial O-ring seals made of FPM (fluorinated rubber) (contents 3 pieces, black)	00532794
4 color rings made of silicone (white, green, red, blue) for visual transmitter identification	00489047
1 color cap set made of PEI (polyetherimide) (contents: 10 pieces, gray) for visual transmitter identification	00525950
1 color cap set made of PEI (polyetherimide) (contents: 10 pieces, brown) for visual transmitter identification	00525951
1 color cap set made of PEI (polyetherimide) (content: 10 pieces, green) for visual transmitter identification	00525952
1 color cap set made of PEI (polyetherimide) (contents: 10 pieces, blue) for visual transmitter identification	00525953
1 PC interface with USB/TTL converter, adapter (socket), and adapter (pins)	00456352
1 holder for wall mounting for Wtrans T01/T02 with protection tube diameter 4 mm	00503317
1 holder for wall mounting for Wtrans T01/T02 with protection tube diameter 4.5 mm	00503326
1 holder for wall mounting for Wtrans T01/T02 with protection tube diameter 6 mm	00503328
1 holder for wall mounting for Wtrans T01/T02 with protection tube diameter 12 mm	00503329
1 machine connector M12 × 1, 4-pin according to IEC 60947-5-2	00506319
1 push-in RTD temperature probe with Pt1000 temperature sensor and machine connector M12 × 1, 4-pin according to IEC 60947-5-2 Type 902150/10-386-1006-2-6-100-56-2500/315,317 Protection tube diameter 6 mm, insertion length 100 mm, Connecting cable length 2500 mm	00514417

2 Identifying the device version

<p>1 push-in RTD temperature probe with Pt1000 temperature sensor and machine connector M12 × 1, 4-pin according to IEC 60947-5-2 Type 902150/10-386-1006-2-6-200-56-2500/315,317 Protection tube diameter 6 mm, insertion length 200 mm, Connecting cable length 2500 mm</p>	<p>00514440</p>
---	-----------------

2 Identifying the device version

2.4 Order details

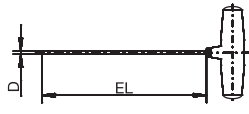
	902930/10	(1) Basic type Wtrans T01.G1 Insertion RTD temperature probes (ambient temperature of housing: -30 to +85 °C)	
x	596	(2) Operating temperature in °C -30 to +260 °C	
x	1006	(3) Measuring insert 1× Pt1000 in 3-wire circuit	
x	2	(4) Tolerance class according to DIN EN 60751 Class A	
x	2.5	(5) Protection tube diameter D in mm Stepped down from Ø 4 mm to Ø 2.5 mm (particularly fast response), available with flat and central probe tip	
x	4	Ø 4 mm	
x	4.5	Ø 4.5 mm	
x	6	Ø 6 mm	
x	100	(6) Insertion length EL in mm (EL 50 to 1000 mm) 100 mm	
x	150	150 mm	
x	200	200 mm	
x	...	For orders, specify in plain text (50 mm increments)	
x	1	(7) Insertion tip Flat	
x	2	Concentric	
x	3	Oblique	
x	10	(8) Radio frequency 868.4 MHz (Europe)	
x	20	915 MHz (America, Australia, Canada, and New Zealand)	
x	000	(9) Process connection None	
x	103	Screw connection G 3/8	
x	104	Screw connection G 1/2	
x	...	Other process connections upon request	
x	000	(10) Extra code None	
x	778	Customer-specific transmission interval of 1 to 3600 s; for orders, specify in plain text (default setting 10 s)	

Order code	(1)	(2)	(3)	(4)	(5)	(6)	(7)	(8)	(9)	(10)
Order example	902930/10	596	1006	2	4	100	2	10	000	000

2 Identifying the device version

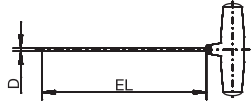
	902930/12	(1) Basic type Wtrans T01.G1 Mineral-insulated RTD temperature probes with flexible protection tube (ambient temperature of housing: -30 to +85 °C)	
x	415	(2) Operating temperature in °C -50 to +600 °C	
x	1006	(3) Measuring insert 1× Pt1000 in 3-wire circuit	
x	2	(4) Tolerance class according to DIN EN 60751 Class A	
x	1.9	(5) Protection tube diameter D in mm Ø 1.9 mm	
x	3	Ø 3 mm	
x	6	Ø 6 mm	
x	100	(6) Insertion length EL in mm (EL 100 to 1000 mm) 100 mm	
x	150	150 mm	
x	...	For orders, specify in plain text (50 mm increments)	
x	1	(7) Insertion tip Flat	
x	10	(8) Radio frequency 868.4 MHz (Europe)	
x	20	915 MHz (America, Australia, Canada, and New Zealand)	
x	000	(9) Process connection None	
x	...	Other process connections upon request	
x	000	(10) Extra code None	
x	778	Customer-specific transmission interval of 1 to 3600 s; for orders, specify in plain text (default setting 10 s)	

Order code	(1)	(2)	(3)	(4)	(5)	(6)	(7)	(8)	(9)	(10)
Order example	902930/12	- 415	- 1006	- 2	- 3	- 100	- 1	- 10	- 000	/ 000

2 Identifying the device version

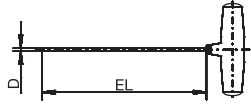
	902930/20	(1) Basic type Wtrans T02.G1 Insertion RTD temperature probes (ambient temperature of housing: -25 to +125 °C)	
x	596	(2) Operating temperature in °C -30 to +260 °C	
x	1006	(3) Measuring insert 1× Pt1000 in 3-wire circuit	
x	2	(4) Tolerance class according to DIN EN 60751 Class A	
x	2.5	(5) Protection tube diameter D in mm Stepped down from Ø 4 mm to Ø 2.5 mm (particularly fast response), available with flat and central probe tip	
x	4	Ø 4 mm	
x	4.5	Ø 4.5 mm	
x	6	Ø 6 mm	
x	100	(6) Insertion length EL in mm (EL 50 to 1000 mm) 100 mm	
x	150	150 mm	
x	200	200 mm	
x	...	For orders, specify in plain text (50 mm increments)	
x	1	(7) Insertion tip Flat	
x	2	Concentric	
x	3	Oblique	
x	10	(8) Radio frequency 868.4 MHz (Europe)	
x	20	915 MHz (America, Australia, Canada, and New Zealand)	
x	000	(9) Process connection None	
x	103	Screw connection G 3/8	
x	104	Screw connection G 1/2	
x	...	Other process connections upon request	
x	000	(10) Extra code None	
x	778	Customer-specific transmission interval of 5 to 3600 s; for orders, specify in plain text (default setting 15 s)	

Order code	(1)	(2)	(3)	(4)	(5)	(6)	(7)	(8)	(9)	(10)
Order example	902930/20	- 596	- 1006	- 2	- 4	- 100	- 2	- 10	- 000	/ 000

2 Identifying the device version

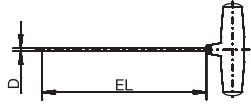
	902930/22	(1) Basic type Wtrans T02.G1 Mineral-insulated RTD temperature probe with flexible protection tube (ambient temperature of housing: -25 to +125 °C)	
x	415	(2) Operating temperature in °C -50 to +600 °C	
x	1006	(3) Measuring insert 1× Pt1000 in 3-wire circuit	
x	2	(4) Tolerance class according to DIN EN 60751 Class A	
x	1.9	(5) Protection tube diameter D in mm Ø 1.9 mm	
x	3	Ø 3 mm	
x	6	Ø 6 mm	
x	100	(6) Insertion length EL in mm (EL 100 to 1000 mm) 100 mm	
x	150	150 mm	
x	...	For orders, specify in plain text (50 mm increments)	
x	1	(7) Insertion tip Flat	
x	10	(8) Radio frequency 868.4 MHz (Europe)	
x	20	915 MHz (America, Australia, Canada, and New Zealand)	
x	000	(9) Process connection None	
x	...	Other process connections upon request	
x	000	(10) Extra code None	
x	778	Customer-specific transmission interval of 5 to 3600 s; for orders, specify in plain text (default setting 15 s)	

	(1)	(2)	(3)	(4)	(5)	(6)	(7)	(8)	(9)	(10)
Order code	<input type="text"/>	- <input type="text"/>	- <input type="text"/>	- <input type="text"/>	- <input type="text"/>	- <input type="text"/>	- <input type="text"/>	- <input type="text"/>	- <input type="text"/>	/ <input type="text"/>
Order example	902930/22	- 415	- 1006	- 2	- 3	- 100	- 1	- 10	- 000	/ 000

2 Identifying the device version

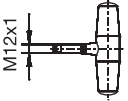
	902930/50	(1) Basic type Wtrans T01.G2 with M12 × 1 plug connection for RTD temperature probe (ambient temperature of housing: -30 to +85 °C)	
x	150	(2) Operating temperature in °C -200 to +600 °C	
x	1006	(3) Measurement input 1× Pt1000 in 3-wire circuit	
x	0	(4) Tolerance class according to DIN EN 60751 Without (not relevant)	
x	0	(5) Protection tube diameter D in mm Without (not relevant)	
x	000	(6) Insertion length EL in mm Without (not relevant)	
x	0	(7) Insertion tip Without (not relevant)	
x	10	(8) Radio frequency 868.4 MHz (Europe)	
x	20	915 MHz (America, Australia, Canada, and New Zealand)	
x	000	(9) Process connection Without (not relevant)	
x	000	(10) Extra code None	
x	778	Customer-specific transmission interval of 1 to 3600 s; for orders, specify in plain text (default setting 10 s)	

	(1)	(2)	(3)	(4)	(5)	(6)	(7)	(8)	(9)	(10)
Order code	<input type="text"/>	- <input type="text"/>	- <input type="text"/>	- <input type="text"/>	- <input type="text"/>	- <input type="text"/>	- <input type="text"/>	- <input type="text"/>	- <input type="text"/>	/ <input type="text"/>
Order example	902930/50	- 150	- 1006	- 0	- 0	- 000	- 0	- 10	- 000	/ 000

2 Identifying the device version

(1) Basic type

902930/60

Wtrans T02.G2
with M12 × 1 plug connection for RTD temperature probe
(ambient temperature of housing: -25 to +125 °C)

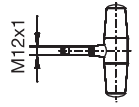

(2) Operating temperature in °C

x 150 -200 to +600 °C

(3) Measurement input

x 1006 1× Pt1000 in 3-wire circuit

(4) Tolerance class according to DIN EN 60751

x 0 Without (not relevant)

(5) Protection tube diameter D in mm

x 0 Without (not relevant)

(6) Insertion length EL in mm

x 000 Without (not relevant)

(7) Insertion tip

x 0 Without (not relevant)

(8) Radio frequency

x 10 868.4 MHz (Europe)

x 20 915 MHz (America, Australia, Canada, and New Zealand)

(9) Process connection

x 000 Without (not relevant)

(10) Extra code

x 000 None

x 778 Customer-specific transmission interval of 5 to 3600 s;
for orders, specify in plain text (default setting 15 s)

	(1)	(2)	(3)	(4)	(5)	(6)	(7)	(8)	(9)	(10)
Order code	<input type="text"/>	- <input type="text"/>	- <input type="text"/>	- <input type="text"/>	- <input type="text"/>	- <input type="text"/>	- <input type="text"/>	- <input type="text"/>	- <input type="text"/>	/ <input type="text"/>
Order example	902930/60	- 150	- 1006	- 0	- 0	- 000	- 0	- 10	- 000	/ 000

2 Identifying the device version

3.1 Inserting/changing the battery

**CAUTION!**

Ensure that soiling, moisture and vapors cannot enter the device.

The device could be destroyed.

- ▶ When inserting/changing the preset lithium battery, ensure that the device is not exposed to soiling, moisture and vapors.
-

**CAUTION!**

The transmitter does not function, if the poles are incorrectly connected.

The battery and the transmitter electronics could be damaged.

- ▶ Ensure that the poles are correctly connected.
-

**CAUTION!**

Incorrect batteries put safety at risk.

The device could be destroyed when using incorrect batteries.

- ▶ Only use the preset lithium battery available as accessories.
Do not solder in the lithium battery.
-

3 Preparing the transmitter

As standard, the transmitter's voltage supply is provided by a lithium battery 3.6 V, 2.2 Ah (1.7 Ah) to be inserted prior to startup.

The battery operating life depends on the configured transmission interval and the ambient temperature. The life span lasts approx. one year with the default settings (transmission interval of 10 s (15 s)) and a room temperature of 25 °C.

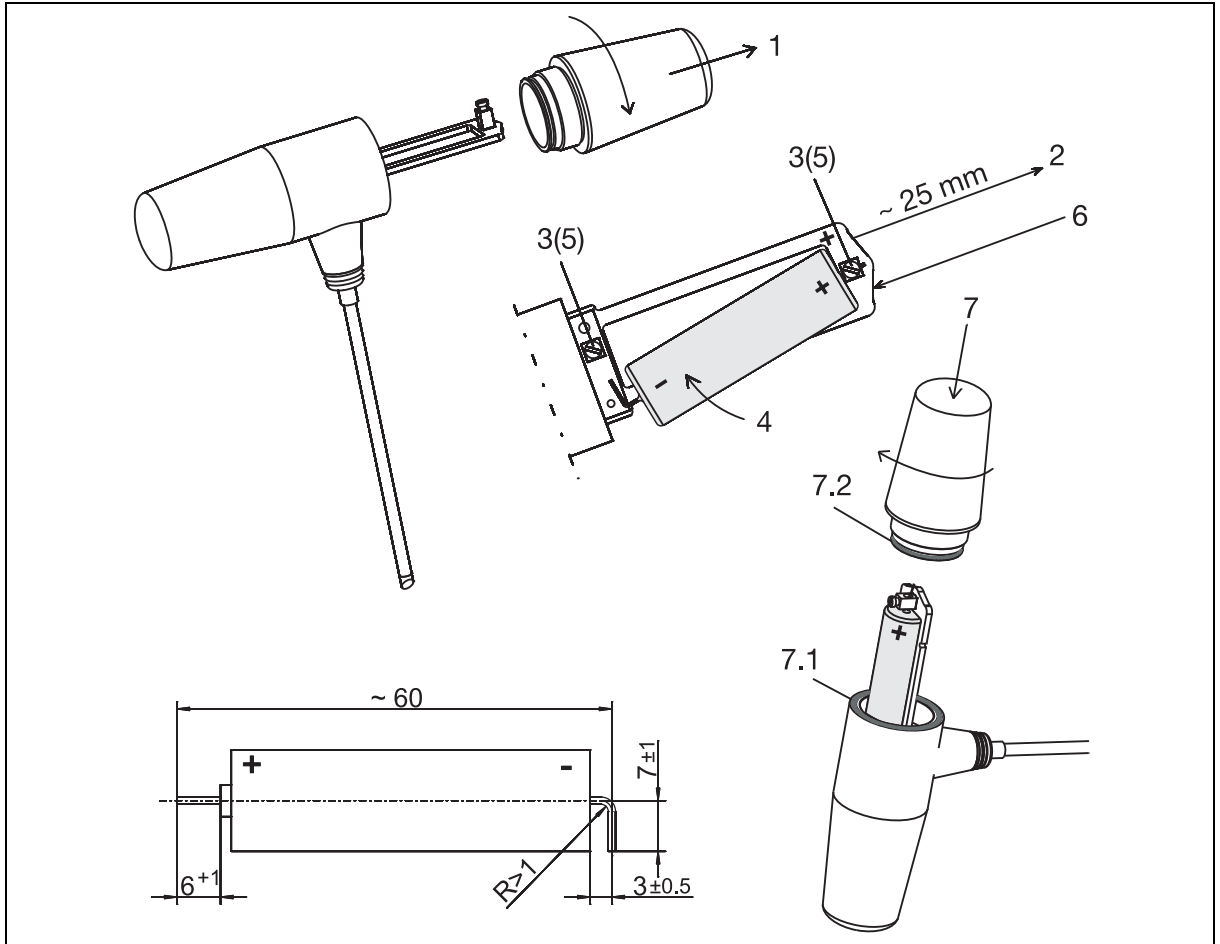

Fig. 3-1 Inserting/changing the battery

1. Unscrew the housing counter-clockwise and pull off the cover.
2. Pull the circuit board out of the basic housing by approx. 25 mm.
Never damage or remove the blue safety cable.
3. Undo the screw terminals of the minus and plus pole using a screwdriver. Remove the battery if empty.
4. Insert the plus pole of the new battery into the (+) screw terminal. Swivel the battery and insert the minus pole into the (-) screw terminal.
5. Tighten the screw terminals of the minus and plus pole using a screwdriver.
6. Slide the circuit board back into the basic housing up to the limit stop.
7. Hold the housing vertically (as shown in the figure) and, moving clockwise, tightly screw the basic housing together with the housing cover.

When doing so, ensure that the two seals 7.1 and 7.2 are correctly fitted on the basic housing and housing cover. The basic housing is correctly screwed to the housing cover when the gap is no longer visible.

3.2 Safety information concerning lithium batteries

⇒ <http://battery.jumo.info>

3.3 Disposal of lithium batteries

Please dispose of all batteries as specified by the legislator according to the German Closed Substance Cycle and Waste Management Act or national regulations.

The contacts of lithium batteries that are not fully discharged electrically need to be insulated. Disposal of batteries together with domestic waste is expressly prohibited. Batteries can be taken to municipal waste collection points or local retailers at no extra charge.

3 Preparing the transmitter

3.4 Battery operating life

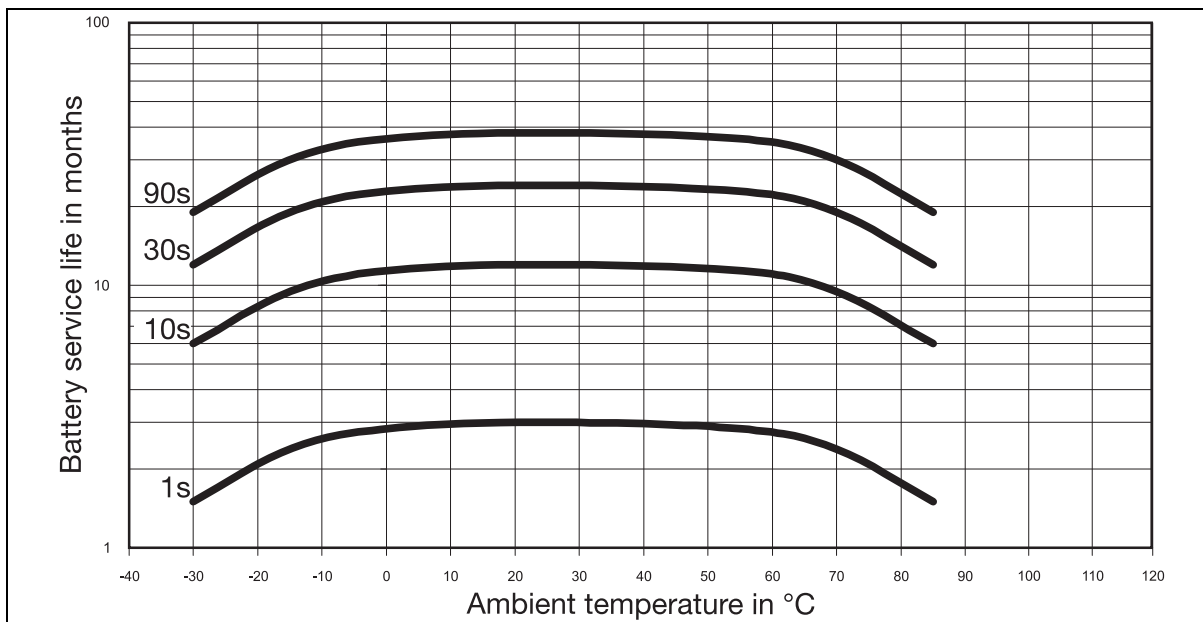

Fig. 3-2 Battery service life depends on the transmission interval (1 s, 10 s, 30 s or 90 s) and the ambient temperature for Wtrans T01

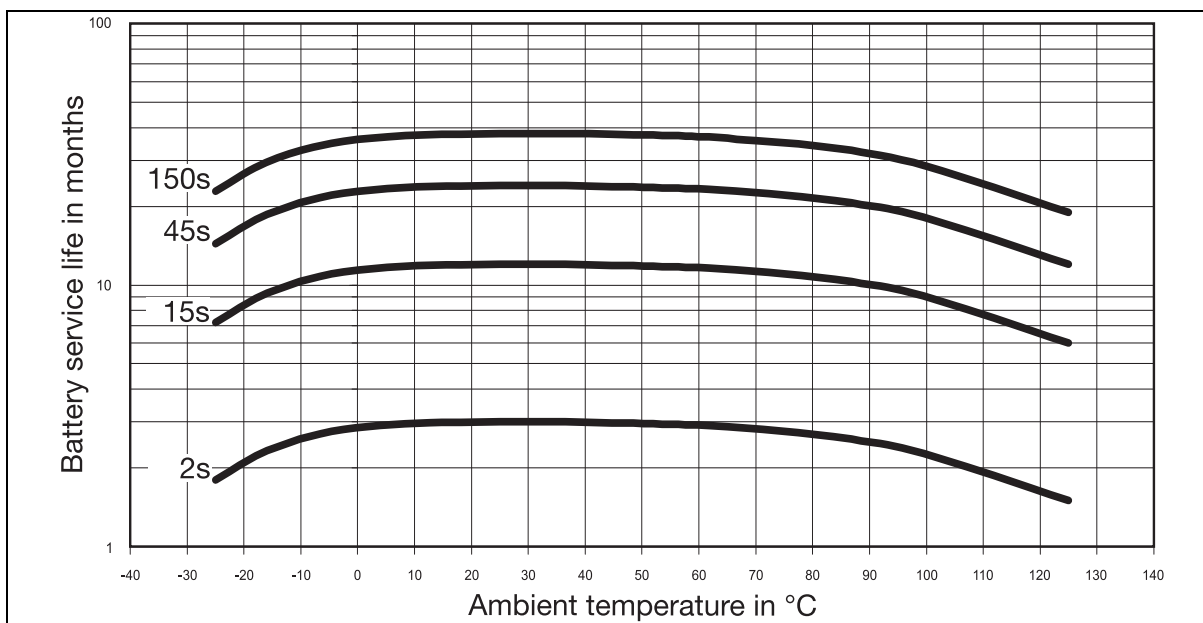

Fig. 3-3 Battery service life depends on the transmission interval (2 s, 15 s, 45 s or 150 s) and the ambient temperature for Wtrans T02

The figures symbolize the dependence of the battery service life on the transmission interval and the average temporarily temperature load and are to be understood as a description.

The specifications concerning battery service life depend on the real application conditions and cannot be understood as guaranteed feature.

The service life can be reduced when the device is used at fast cyclical temperature changes or when permanently operated at the temperature limit values.

3.5 Attaching the color coding of a transmitter

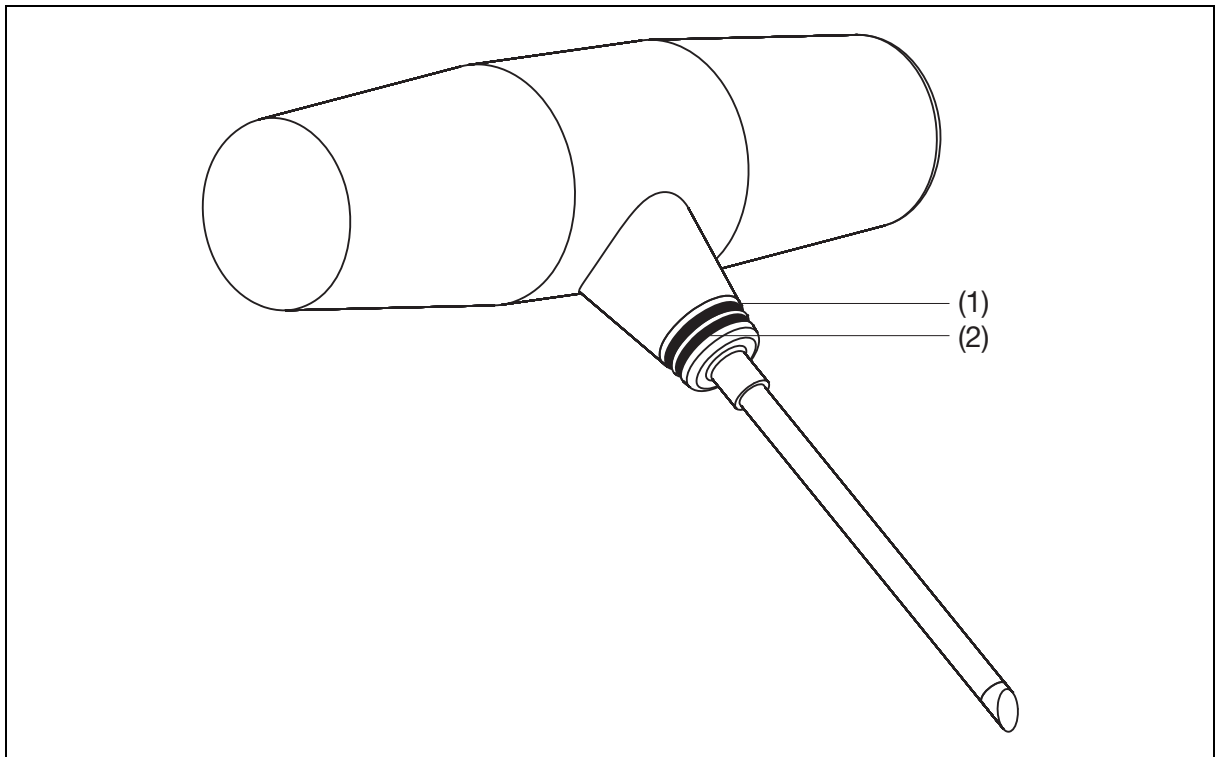

Fig. 3-4 Attaching the color coding of a transmitter

- 1 Top color coding
- 2 Bottom color coding

Per default, the transmitter comes with four color rings made of silicone (white, green, red, and blue), with which the transmitters can be clearly identified visually.

Proceed as follows to clearly mark the transmitters visually:

1. To add a clear combination of silicone rings on the transmitter, push the rings onto the transmitter shaft.
2. Write down the color combinations of the transmitter.



NOTE!

Color caps (colored housing covers in gray, brown, green or blue) for the visual transmitter identification are available as accessories as an alternative to the color rings.

The color caps can be replaced by screw-on case covers.

3 Preparing the transmitter

4.1 General information about wireless transmission

Wireless signals are electromagnetic waves, the signal of which weakens during travel from the transmitter to the receiver (this is referred to as path attenuation). The field strength reduces inversely proportional to the square of the distance between the transmitter and receiver.

In addition to this natural range restriction, a reduced range may also be caused by the following:

- Ferroconcrete walls, metallic objects and surfaces, heat insulation, or heat-absorbing windows with a vapor-deposited metal layer reflect and absorb electromagnetic waves, meaning a dead spot is formed behind them.
- Metal tubes, chains, etc. on the transmitter housing; therefore, do not fasten any metallic objects to the transmitter housing.
- Insufficient spacing between several transmitters; therefore, ensure a minimum spacing of 20 cm.
- The antenna is installed at an insufficient height; therefore, install as high as possible above the ground and ensure there is a line of sight between the transmitter and receiver.

The following values are reference values concerning the permeability of wireless signals:

Material	Permeability
Wood, plaster, glass (uncoated)	90 to 100 %
Brickwork, press boards	65 to 95 %
Armored concrete	10 to 90 %
Metal, aluminum lamination	0 to 10 %

When using the antenna holder for wall mounting for the receiver, the open air range between the transmitter and the receiver is 300 m. Optimum reception is achieved when a line of sight can be established between the transmitter and the receiver.

If the receiver is mounted in a control cabinet, behind concrete walls, or behind concrete ceilings, the antenna must always be installed with the receiver holder for wall mounting and antenna cable pointing in the direction of the transmitters.

4 Transmission range

4.2 Possible impairment of radio transmission

Collisions when using an excessive number of transmitters

When using a large number of transmitters, do not select a transmission interval which is too low, otherwise the radio channel will be unnecessarily occupied. A too low transmission interval means a very high data volume on the selected frequency which can lead to collisions with other transmitters. Telegrams can be destroyed during radio transmission caused by collisions.

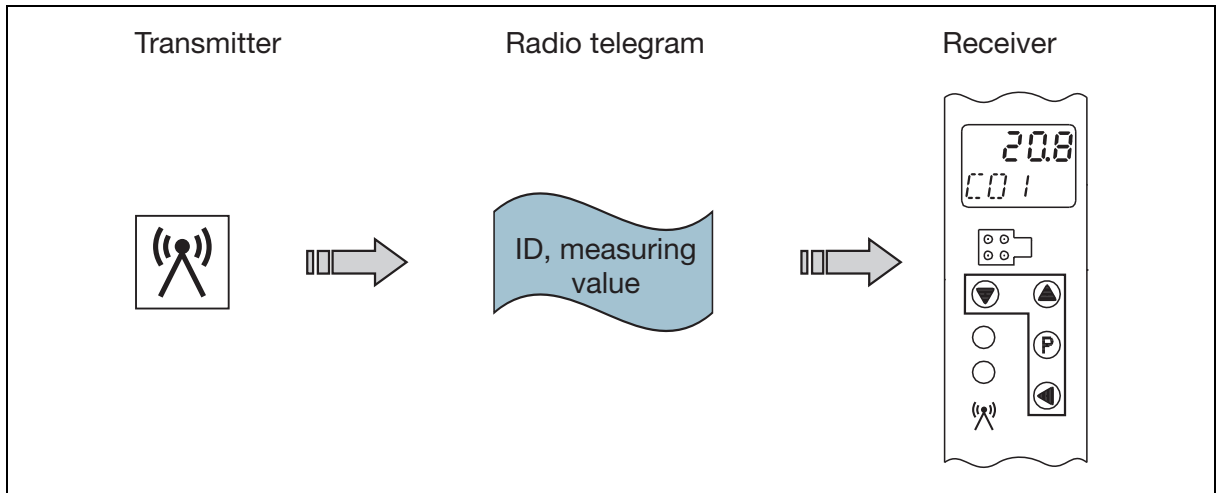

Fig. 4-1 The telegrams of a transmitter reach the receiver without collisions.

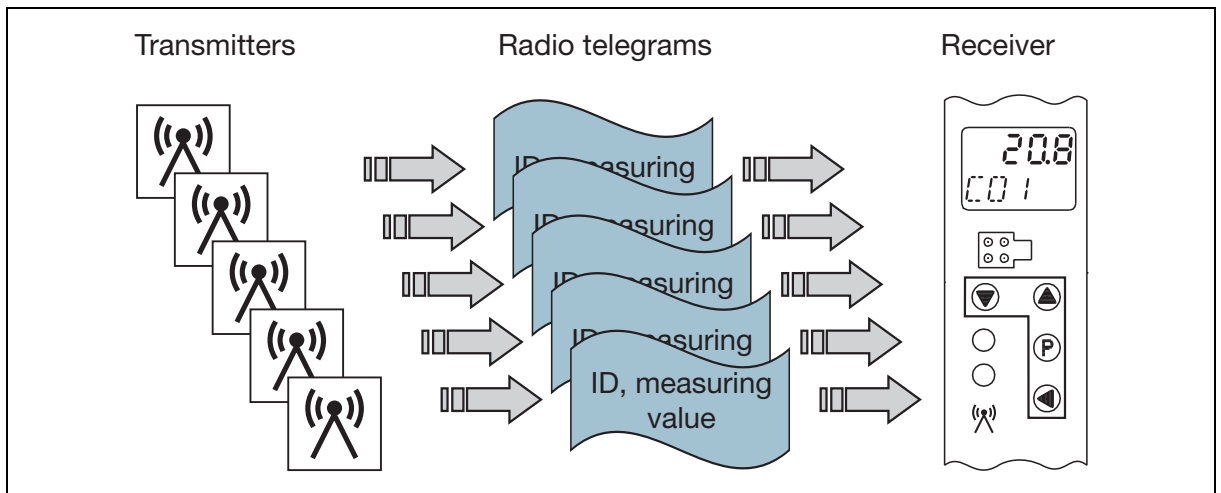

Fig. 4-2 Telegrams of several transmitters can collide.

4 Transmission range

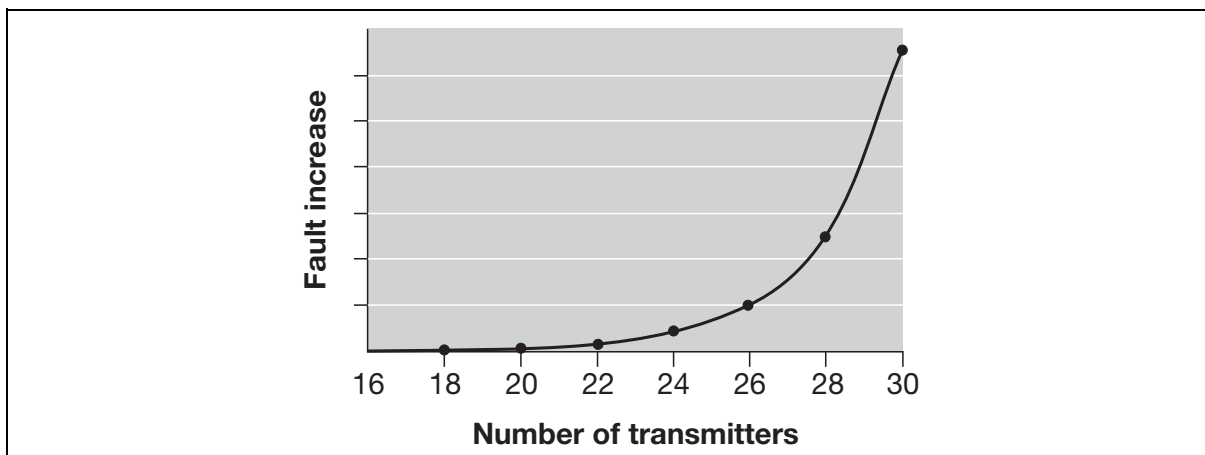

Fig. 4-3 Collisions depending on the number of transmitters at a transmission interval of 1 s

As the Fig. 4-3 shows, the error curve increases sharply once 24 transmitters are reached.

For this reason, we recommend using a maximum of 16 transmitters for the smallest transmission interval of 1 s. For the factory setting of 10 s, a considerably larger number of transmitters is possible.

Estimating the maximum number of transmitters

If more than the recommended 16 transmitters are to be used with a transmission interval of 1 s, select a higher transmission interval to prevent an increased error quota.

Example:

16 transmitters with a transmission interval of 1 s = 32 transmitters with a transmission interval of 2 s

The calculation displayed in the next example applies when the number of transmitters is to be increased further.

Example:

16 transmitters with a transmission interval of 1 s = 48 transmitters with a transmission interval of 3 s (in theory)

However, from a transmission interval of ≥ 3 s, the telegram is transmitted twice. This means the number of transmitters that can be used is cut in half.

16 transmitters with a transmission interval of 1 s = 24 transmitters with a transmission interval of 3 s (effective)

The same occurs with a transmission interval of ≥ 60 s. As of this transmission interval the telegram is transmitted three times.

External transmitters

The frequency bands used by the device are also freely available to other users. External transmitters can transmit on the same frequency. If, for example, the transmitter and an external transmitter transmit their wireless telegrams at the same time, the telegram is destroyed. No error is detected because the transmitters cannot check their own transmission while transmitting.

Electrical devices

In a harsh industrial environment, wireless telegrams can be destroyed by such things as frequency converters, electrical welding equipment, poorly shielded PCs, audio/video devices, electronic transformers, electronic ballasts, etc.

4 Transmission range

Error map-out

The radio transmission timeout parameter on the receiver can be used to map out lost telegrams (either by external influence or collisions caused by a large number of probes) and no error message appears. The value received last is retained over 2 to 10 transmission intervals and the alarm radio transmission timeout is only then activated (display "----").



NOTE!

In the event of collisions caused by an excessive number of transmitters, observe and, if necessary, correct the factors "number of transmitters", "transmission intervals", and, on the receiver, "wireless time-out".

5.1 Information about fastening, securing and arrangement



NOTE!

When fastening or securing a transmitter to prevent it from falling, ensure that the plastic housing is not wrapped with metallic objects (e.g. chains or circlips). Otherwise, the transmitter range will be impaired.



NOTE!

For optimum transmitter function, ensure minimum spacing of 200 mm between the transmitters.



NOTE!

To prevent damage to the protection tube, do not subject the transmitter to undue force when pushing into solid media.

5 Mounting

5.2 Wall holder dimensions

Wall holder for sheath diameter 4 mm, 4.5 mm, 6 mm and 12 mm

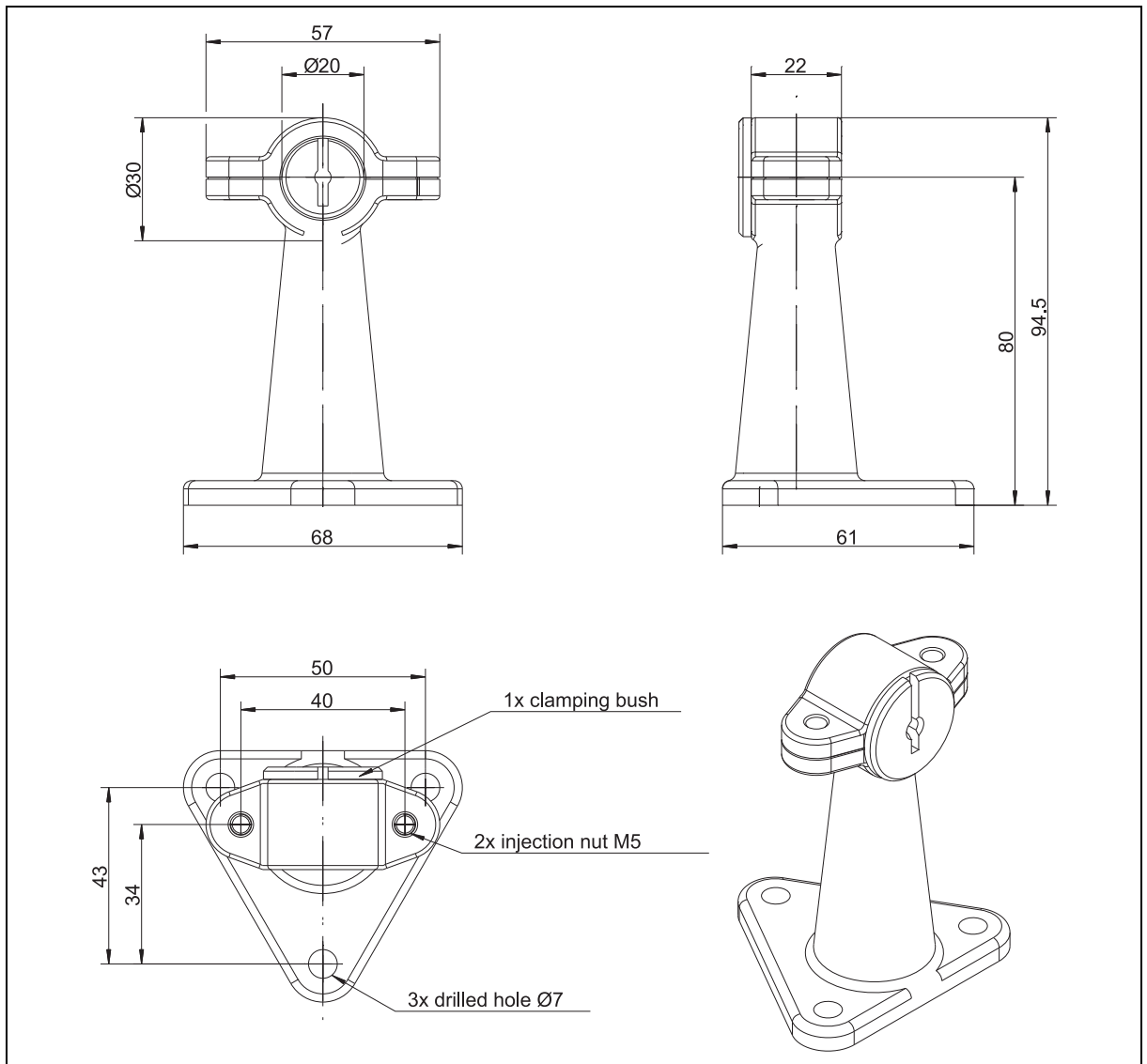

Fig. 5-1 Wall holder dimensions

5.3 Installing the holder for wall mounting and transmitter

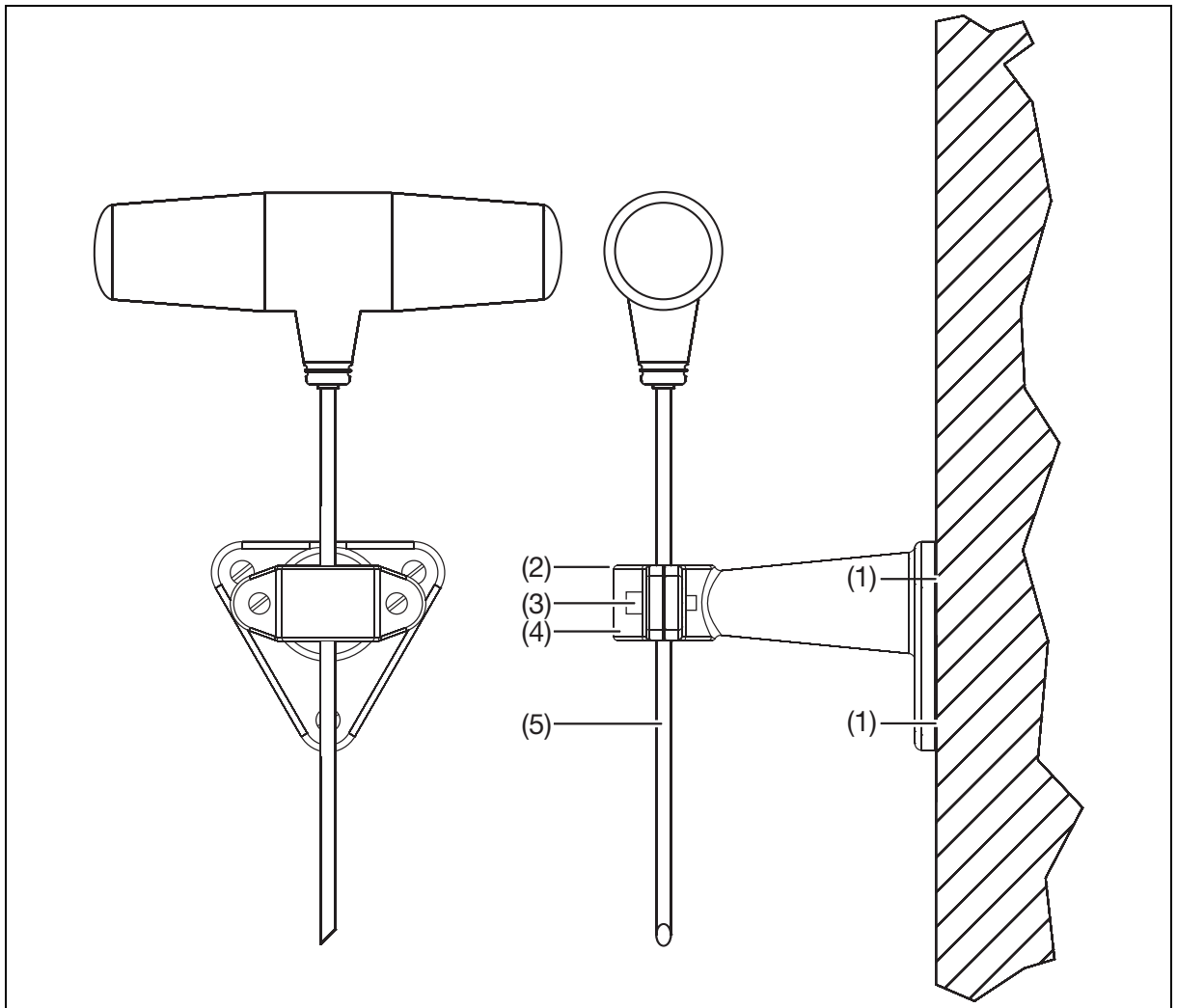

Fig. 5-2 Installing the holder for wall mounting and transmitter

- 1 Holes for holder for wall mounting
- 2 Clamping bush (use for different protection tube diameters)
- 3 Cylinder head screws M5
- 4 Plastic clamp
- 5 Transmitter protection tube

Proceed as follows to install the holder for wall mounting and the transmitter:

1. Fasten the holder for wall mounting to the wall using three suitable screws and dowels (not included in the scope of delivery).
2. Insert the clamping bush into the holder for wall mounting from above. Align the open end of the guide in the direction of the wall. Slightly tighten the two M5 cylinder head screws using a screwdriver.
3. Insert the protection tube into the clamping bush from above and tighten with the two M5 cylinder head screws.

5 Mounting

6 Connection diagram

6.1 Machine connector M12 × 1, 4-pin according to IEC 60947-5-2

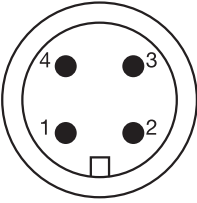
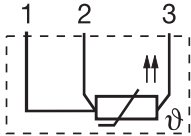
	Electrical connection	Connection assignment
	Basic type 902930/50 and 902930/60	
	RTD temperature probe in three-wire circuit (input)	



NOTE!

For safe, interference-free device operation, only connect shielded measuring inserts with shielded cables and connected shielding on both sides (shielding connected to protection tube and to machine connector M12).

6 Connection diagram

7.1 General information about the setup program

The setup program serves to configure transmitters and receivers by means of a PC. The configuration data can be archived on data carriers and printed.

Configurable parameters include:

- Transmitter detection (transmitter ID)
- Transmission interval
- Radio frequency (for 915 MHz only)

The default settings are:

- Transmitter detection (transmitter ID), consecutive
 - Transmission interval (10 s) or (15 s), depending on the basic type
 - Radio frequency 868.4 MHz (Europe) or 915.4 MHz (America, Australia, Canada, and New Zealand)
- In the 915 MHz frequency band, ten frequencies can be configured for the transmitter and receiver

The setup program can be used to overwrite changed parameters with the default settings at any time.

The connection between the transmitter and PC is established via a PC interface (USB/TTL converter).

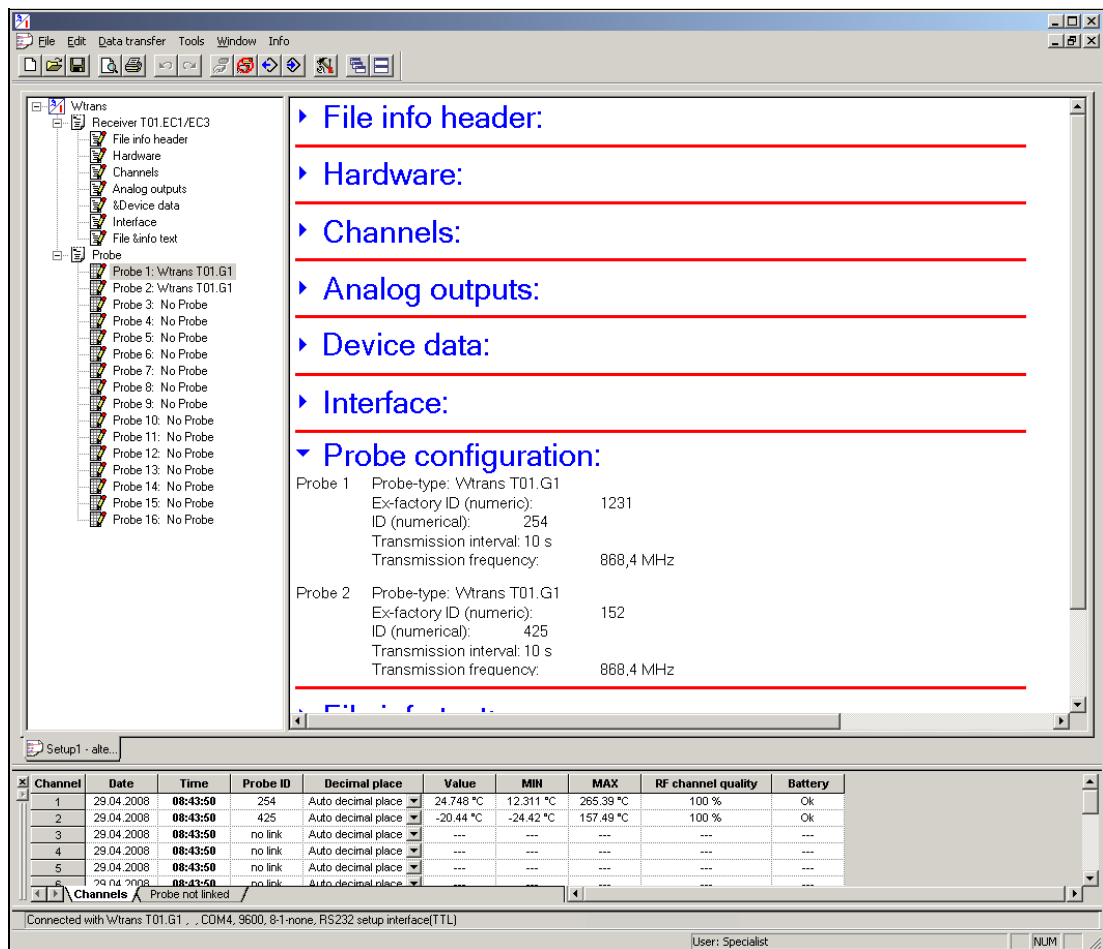

Fig. 7-1 Setup program of the transmitter

7 Setup program

7.2 Hardware and software requirements

The hardware and software requirements can be obtained from the manufacturer's website.



NOTE!

If no connection can be established with the transmitter or receiver using the setup program, the setup program must be updated.

The latest version of the setup program can be downloaded from the manufacturer's website.

7.3 Establishing the connection between PC and transmitter

The connection between the transmitter and PC is established via a PC interface (USB/TTL converter) and adapter (socket).



CAUTION!

Permanent interface operation!

The PC interface USB/TTL converter is only designed for a time-limited interface connection.

- ▶ Please ensure that the interface connection is disconnected and the transmitter correctly closed once the setup data transfer is completed.
-



CAUTION!

Low battery!

A low battery can lead to interface problems and result in an incorrect configuration or data loss.

- ▶ Please ensure that the battery used for the connection between the PC and transmitter never reaches the "Low battery" status.
-

7 Setup program

USB/TTL

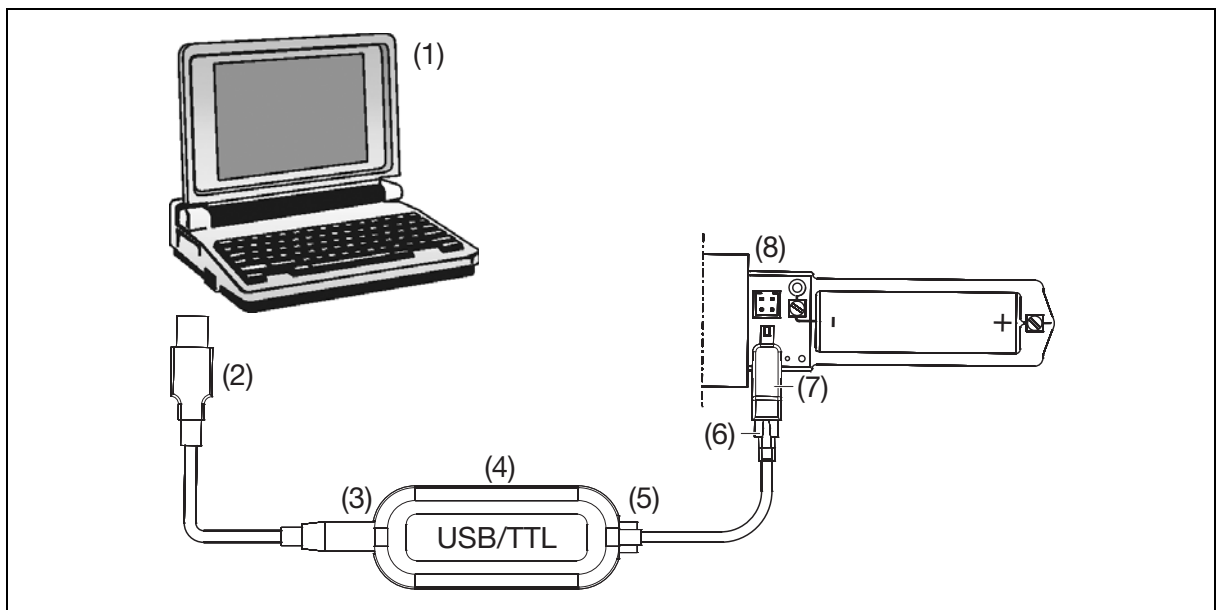

Fig. 7-2 Establish the connection between the PC and transmitter via USB/TTL converter and adapter socket

- 1 Laptop/PC
- 2 USB connector
- 3 USB socket
- 4 USB/TTL converter
- 5 Modular jack RJ-45
- 6 Adapter of the modular cable
- 7 Adapter socket, 4-pin
- 8 Transmitter interface

For the setup via USB/TTL converter, establish the following connections:

Procedure:

1. Insert the USB connector of the USB cable (2) into the laptop/PC (1).
2. Open the transmitter.
⇒ chapter 3.1 "Inserting/changing the battery", Page 19
3. Insert the USB socket of the USB cable (3) into the connector of the USB/TTL converter (4).
4. Connect the RJ-45 connector (5) of the modular line to the RJ-45 socket of the USB/TTL converter (4).
5. Connect the 4-pin adapter socket (7) to the adapter of the modular line (6).
6. Connect the adapter socket, 4-pin, (7) to the transmitter interface (8).

7.4 Transmitter configuration

This chapter explains the configuration of a transmitter via the setup program. Prerequisite being that the transmitter and the PC are connected via an interface.

7.4.1 Establishing the communication

There are two different ways of establishing communication between the transmitter and the setup program:

- Establishing communication using the "Assistant for device settings".
This is the case when the setup program is used for the first time (device list empty).
- Establish communication without using the "Assistant for device settings".
This is the case when the receiver/transmitter and setup program have already communicated (device list with entries).

Establishing communication using the assistant

Procedure:

1. Start the setup program.
2. Select the "Establish connection" function in the "Data transfer" menu.
Once the setup program has started, the "Assistant for the device settings" appears.
3. Select the transmitter under the "Device version" and confirm by pressing "Next".
4. Confirm the PC communication interface "Serial interface" by pressing "Next".
5. Select the serial interface (e.g. COM1) and confirm with "Next".
6. Confirm the MU protocol (transmitter) by pressing "Continue".
7. Exit the assistant by clicking "Finish".
The device list with the selected transmitter appears.
8. Click the "Connect" button.
The device list is closed, the assistant is exited, and communication between the transmitter and setup program is established.

Establishing communication without using the assistant

Procedure:

1. Start the setup program.
2. Select the "Establish connection" function in the "Data transfer" menu.
The device list containing all devices entered is displayed.
3. Left-click the desired transmitter to select it.
4. Click the "Connect" button.
The device list is closed, the assistant is exited, and communication between the transmitter and setup program is established.

7 Setup program

7.4.2 Reading the current transmitter parameters

Procedure:

1. In the "File" menu, select the "New" function.
The "Device assistant" starts.
2. Confirm the "User-defined setting" by clicking the "Next" button.
3. Select the "Frequency band" and confirm with "Next".
4. Select the receiver variant and confirm by clicking "Next".
5. Exit the overview of the selected settings by clicking "Finish".
The current settings are displayed in the setup program.
6. Select the desired transmitter from the navigation tree by left-clicking it.
7. In the "Data transfer" menu, select the "Data transfer from device" function.
8. Exit the "Save file" prompt by clicking "Skip".
The current transmitter parameters are imported into the setup program.

7.4.3 Editing transmitter parameters

Procedure:

1. In the navigation tree, select the transmitter to be edited by left-clicking it twice.
The "Transmitter configuration" is opened.
2. Edit the desired parameters.
3. Exit the editing procedure with "OK".
4. Save the parameters in the "File" menu with the "Save" function.

7.4.4 Transmitting new parameters to the transmitter

Procedure:

1. In the "Data transfer" menu, select the "Data transfer to device" function.
The current parameters are transmitted to the transmitter.
2. End communication between the setup program and transmitter in the "Data transfer" menu using the "Disconnect connection" function.

7.5 Parameter overview

Parameters	Default setting	Value range/Selection	
Transmitter detection (transmitter ID)	Deactivated	1 to 99999	
Transmission interval	10 s (15 s)	1 to 3600 s	
Radio frequency	868.4 MHz 915.4 MHz	868.4 MHz with 868 MHz hardware 912.6 MHz with 915 MHz hardware 913.0 MHz 913.6 MHz 914.0 MHz 914.6 MHz 915.4 MHz 916.0 MHz 916.4 MHz 917.0 MHz 917.4 MHz	



NOTE!

At a transmission interval of > 15 s, the transmitter transmits a so-called Link telegram, i. e. the telegrams are transmitted at the default intervals for a period of 30 minutes, and only afterwards at the set transmission interval.



NOTE!

If the setup connector is connected, the transmitter automatically transmits telegrams at a transmission interval of 1 s to enable the receiver to detect changes immediately. After the setup connector is removed, the telegrams are transmitted again at the set transmission interval.

Term definition

Transmitter detection (transmitter ID)

The transmitter detection (transmitter ID) is a unique ID with max. 5 characters, which is recognized by the receiver. The ID can be individually changed, for example, to obtain a better overview of the plant. However, ensure that an ID is only assigned once within the reception range to avoid malfunctions.

Transmission interval

This parameter defines the time intervals used to transmit data to a receiver. The setting of the "Transmission interval" parameter affects the battery operating life. For this reason, exercise caution and do not consider transmission quality only when selecting the interval.

Radio frequency

The radio frequency defines the frequency band used to transmit data to a receiver. The radio frequency in Europe has been specified as 868.4 MHz because special regulations regarding the transmission interval and transmission power are determined for the frequency band. In the 915 MHz frequency band, 10 frequencies are selectable.

7 Setup program

8 Technical data

Analog input

Measurement input	Pt1000 according to DIN EN 60751 in 3-wire circuit
Operating temperature range	-30 to +260 °C for basic types 902930/10 and 902930/20; -50 to +600 °C for basic types 902930/12 and 902930/22; -200 to +600 °C for basic types 902930/50 and 902930/60; The admissible ambient temperature range of the housing must be noted.
Accuracy of the temperature sensor	Class A $\pm(0.15 \text{ K} + 0.002 \times t)$ $ t $ = measured temperature in °C without prefix sign
Sensor line resistance	$\leq 11 \text{ ohm}$ per lead with 3-wire circuit
Sensor current	$\leq 500 \text{ }\mu\text{A}$
Measuring circuit monitoring	Detection of probe break and probe short circuit

Output (wireless transmission)

Transmitter detection (transmitter ID)	Max. 5-digit ID, default setting, can be configured for the specific customer
Transmission interval	Adjustable from 1 to 3600 s; For basic types 902930/10, 902930/12, and 902930/50 (default setting = 10 s); Adjustable from 5 to 3600 s; For basic type 902930/20, 902930/22, and 902930/60 (default setting = 15 s);
Radio frequency	868.4 MHz (Europe); 915 MHz (America, Australia, Canada, and New Zealand); In the 915 MHz frequency band, ten frequencies can be configured
Transmission power	< +10 dBm
Open air range	300 m with 868.4 MHz, 100 m with 915 MHz when using the antenna holder for wall mounting for the receiver and the 3 m antenna cable. When mounting the antenna directly to the receiver, a reduction in the range of approx. 40 % must be taken into account.
Output signal	882.2 to 1977.1 ohm corresponds to -30 to +260 °C; 185.2 to 3137.1 ohm corresponds to -200 to +600 °C;
Response time of the complete probe	0.4 m/s in water / 3.0 m/s in air Ø 4.0 mm: Water $t_{0.5}$ approx. 3 s, $t_{0.9}$ approx. 7 s / air $t_{0.5}$ approx. 25 s, $t_{0.9}$ approx. 80 s Ø 6.0 mm: Water $t_{0.5}$ approx. 4 s, $t_{0.9}$ approx. 10 s / air $t_{0.5}$ approx. 32 s, $t_{0.9}$ approx. 98 s
Calibration accuracy of the electronics	$\leq \pm 0.05 \text{ \%}^a$
Configuration	with setup program
Configurable parameters	Transmitter ID (max. 5-digit ID), transmission interval, Radio frequency (for 915 MHz only)

^a All accuracy specifications in % relating to the measuring range of 290 K or 800 K.

Voltage supply

Lithium battery	Voltage: 3.6 V (— Symbol for direct voltage), rated capacity: 2.2 Ah For basic types 902930/10, 902930/12 and 902930/50; Voltage: 3.6 V (— Symbol for direct voltage), rated capacity: 1.7 Ah For basic types 902930/20, 902930/22 and 902930/60
Operating life	Approx. 1 year with the default settings and at room temperature (a fast transmission interval and a high or low ambient temperature will reduce the operating life of the lithium battery)
Battery change	Only use the preconfigured lithium battery that is available in the accessories

8 Technical data

Environmental influences

Ambient temperature range of the housing	-30 to +85 °C (housing incl. electronics) For basic types 902930/10, 902930/12 and 902930/50; -25 to +125 °C (housing incl. electronics) For basic types 902930/20, 902930/22 and 902930/60
Storage temperature range	-40 to +85 °C (housing incl. electronics) For basic types 902930/10, 902930/12 and 902930/50; -40 to +125 °C (housing incl. electronics) For basic types 902930/20, 902930/22 and 902930/60
Temperature influence	$\leq \pm 0.0025 \%^a/K$; per K deviation from the reference temperature 22 °C (± 3 K) (housing)
Site altitude	Max. 2000 m above sea level
Resistance to climatic conditions	Rel. humidity ≤ 95 % without condensation according to IEC 68-2-30
Vibration resistance	Max. 2 g at 10 to 2000 Hz (relating to the housing including electronics) According to DIN IEC 60 068-2-6
Admissible mechanical shock resistance	25 g/6 ms (relating to the housing including electronics) DIN IEC 68-2-29 per 1000 cycles
Electromagnetic compatibility (EMC) - Interference emission - Interference immunity - Radio frequency spectrum	DIN EN 61326-1 Class B – household and small businesses – Industrial requirement ETSI EN 300 220-1 and ETSI EN 300 220-2

^a All accuracy specifications in % relating to the measuring range of 290 K or 800 K.

Housing

Material	PEI (polyetherimide), color: black or gray
Flammability class	UL 94 HB
Dimensions	Diameter approx. 32 mm, length approx. 126 mm; For insertion lengths, refer to order details
Mounting	Optional wall mounting by means of holder for wall mounting (use inside and outside of buildings)
Protection type	IP67 according to DIN EN 60529 For basic types 902930/10, 902930/12, 902930/20 and 902930/22; For basic types 902930/50 and 902930/60; Only with screwed-on machine connector M12 × 1
Cleaning	The device can be cleaned with conventional washing, rinsing, and cleaning agents
Installation position	Any
Weight	Approx. 120 g (without protection fitting)

Approvals / approval marks

Approval mark	Test facility	Certificates / certification numbers	Inspection basis	Valid for
c UL us	Underwriters Laboratories	E201387	UL 61010-1 CAN/CSA-22.2 No. 61010-1	3.6 V, Basic type 902930/10 Basic type 902930/12 Basic type 902930/20 Basic type 902930/22 Basic type 902930/50 Basic type 902930/60

8 Technical data

IC	Industry Canada	7472A-WTRANST01 7472A-WTRANST0102	RSS210 Issue 7 RSS-210 Issue 8 RSS-GEN Issue 3 RSS-102 Issue 4	915 MHz, Basic type 902930/10 915 MHz, Basic type 902930/10 Basic type 902930/12 Basic type 902930/20 Basic type 902930/22 Basic type 902930/50 Basic type 902930/60
FCC	Federal Communications Commission	VT4-WTRANST01 VT4-WTRANST0102	FCC Rule Part 15C FCC Rule Part 15C	915 MHz, Basic type 902930/10 915 MHz, Basic type 902930/10 Basic type 902930/12 Basic type 902930/20 Basic type 902930/22 Basic type 902930/50 Basic type 902930/60

8 Technical data

		有毒有害物质或元素 Hazardous substances						
								
部件名称		铅 (Pb)	汞 (Hg)	镉 (Cd)	六价铬 (Cr(VI))	多溴联苯 (PBB)	多溴二苯醚 (PBDE)	
Product group: 902930								
外壳 Housing (Gehäuse)	过程连接 Process connection (Prozessanschluss)	X	○	○	○	○	○	
-螺母 Nut (Mutter)		○	○	○	○	○	○	
螺钉 Screw (Schraube)		X	○	○	○	○	○	

本表格依据 SJ/T 11364-2014的规定编制。
 (This table is prepared in accordance with the provisions of SJ/T 11364-2014.)
 O : 表示该有害物质在该部件所有均质材料中的含量均在 GB/T 26572 规定的限量要求以下。
 (O: Indicates that said hazardous substance contained in all of the homogeneous materials for this part is below the limit requirement of GB/T 26572.)
 X : 表示该有害物质至少在该部件的某一均质材料中的含量超出 GB/T 26572 规定的限量要求。
 (X: Indicates that said hazardous substance contained in one of the homogeneous materials used for this part is above the limit requirement of GB/T 26572.)

9 China RoHS



JUMO GmbH & Co. KG

Street address:
Moritz-Juchheim-Straße 1
36039 Fulda, Germany

Delivery address:
Mackenrodtstraße 14
36039 Fulda, Germany

Postal address:
36035 Fulda, Germany

Phone: +49 661 6003-0
Fax: +49 661 6003-607
Email: mail@jumo.net
Internet: www.jumo.net

JUMO UK LTD

JUMO House
Temple Bank, Riverway
Harlow, Essex, CM20 2DY, UK

Phone: +44 1279 63 55 33
Fax: +44 1279 62 50 29
Email: sales@jumo.co.uk
Internet: www.jumo.co.uk

JUMO Process Control, Inc.

6724 Joy Road
East Syracuse, NY 13057, USA

Phone: +1 315 437 5866
Fax: +1 315 437 5860
Email: info.us@jumo.net
Internet: www.jumousa.com

