

# JUMO Wtrans E01

Measuring probe for humidity, temperature,  
and CO<sub>2</sub> with wireless data transmission



Operating Manual



90292800T90Z001K000

V4.00/EN/00599280/2022-02-15



<b>1</b>	<b>Introduction</b>	<b>7</b>
1.1	Safety information	7
1.2	Brief description	8
1.3	Block diagram	8
1.4	Connection elements	9
1.4.1	View from below	9
1.4.2	View from above	9
1.4.3	Rear view	10
1.5	Dimensions	11
1.5.1	Measuring probe	11
1.5.2	Sensors and lambda/4 antenna	11
1.6	Declaration of conformity	12
<b>2</b>	<b>Identifying the device version</b>	<b>13</b>
2.1	Nameplate	13
2.2	Order details	14
2.3	Scope of delivery	14
2.4	Accessories	15
<b>3</b>	<b>Preparing the measuring probe</b>	<b>17</b>
3.1	Receiver software version	17
3.2	Supply with batteries	17
3.2.1	Inserting/changing the battery	17
3.2.2	Safety information concerning lithium batteries	19
3.2.3	Battery operating life	20
3.2.4	Disposal of batteries	20
3.3	Supply with external voltage supply	21
3.4	Antenna installation	23
3.4.1	Installing the antenna	23
3.4.2	Installing antenna cable	24
<b>4</b>	<b>Transmission range</b>	<b>25</b>
4.1	General information about wireless transmission	25
4.2	Possible impairment of wireless transmission	26
<b>5</b>	<b>Mounting</b>	<b>29</b>
5.1	Notes about mounting, arrangement, and safety	29
5.2	Safety information	29
5.3	Mounting and dismounting the measuring probe	30

---

# Contents

---

<b>6</b>	<b>Electrical connection</b>	<b>31</b>
6.1	Installation notes	31
6.2	Voltage supply	31
6.3	Input	31
6.4	Output	32
6.5	Interface	32
<b>7</b>	<b>Introduction to operation</b>	<b>33</b>
7.1	Display and control elements	33
7.2	Normal display (NA) (displaying measured values)	34
7.3	Startup level (In) (measuring and transmitting measured values quickly)	37
7.4	Parameter level (PA) (configuring parameters)	38
<b>8</b>	<b>Operating the measuring probe</b>	<b>39</b>
8.1	Normal display (NA)	40
8.2	Displaying measured values	40
8.3	Changing to different levels	41
8.4	Code request	42
<b>9</b>	<b>Configuring the transmitter</b>	<b>45</b>
9.1	Startup level (In)	45
9.2	Parameter level (PA)	46
9.2.1	Editing parameters	47
9.2.2	General parameters	48
9.2.3	Measured value-specific parameters	48
<b>10</b>	<b>Setup program</b>	<b>51</b>
10.1	Setup program	51
10.1.1	Interface	52
10.2	Hardware and software requirements	52
10.3	Establishing the connection between the laptop/PC and measuring probe	52
10.4	Configuring the transmitter	54
10.4.1	Establishing the communication	54
10.4.2	Extracting the current transmitter parameters	54
10.4.3	Editing the transmitter parameters	55
10.4.4	Transferring new parameters to the transmitter	55
<b>11</b>	<b>Technical data</b>	<b>57</b>
11.1	JUMO Wtrans E01	57
11.1.1	Sensor inputs 1 and 2	57
11.1.2	Output (wireless transmission)	57

---

11.1.3	Display .....	.58
11.1.4	Electrical data .....	.58
11.1.5	Environmental influences .....	.59
11.1.6	Case .....	.59
11.2	Sensors .....	.60
<b>12</b>	<b>China RoHS .....</b>	<b>61</b>

# Contents

---

---

## 1.1 Safety information

### General

This manual contains information that must be observed in the interest of your own safety and to avoid material damage. This information is supported by symbols which are used in this manual as indicated.

Please read this manual before starting up the device. Store this manual in a place that is accessible to all users at all times.

If difficulties occur during startup, please do not intervene in any way that could jeopardize your warranty rights!

### Warning symbols



#### CAUTION!

This symbol in connection with the signal word indicates that **material damage or data loss** will occur if the respective precautionary measures are not taken.

---



#### CAUTION!

This symbol indicates that **components could be destroyed** by electrostatic discharge (ESD = Electro Static Discharge) if the respective cautionary measures are not taken.

Only use the ESD packages intended for this purpose to return device inserts, assembly groups, or assembly components.

---



#### READ THE DOCUMENTATION!

This symbol, which is attached to the device, indicates that the associated **documentation for the device** must be **observed**. This is necessary to identify the nature of the potential hazard, and to take measures to prevent it.

---

### Note symbols



#### NOTE!

This symbol refers to **important information** about the product, its handling, or additional benefits.

---



#### REFERENCE!

This symbol refers to **additional information** in other sections, chapters, or other manuals.

---

# 1 Introduction

## 1.2 Brief description

The Wtrans E01 measuring probe is used in combination with a Wtrans receiver for recording measured values using digital sensors for humidity, temperature, and CO<sub>2</sub>. The measuring probe has two inputs with plug connectors M12 × 1 to which the sensors can be connected and where the sensors are detected in any combination (plug and play).

Other measurands can be derived from the measured values determined. Up to four measured values are recorded. They are transmitted to the receiver of the Wtrans measuring system at a radio frequency of 868.4 MHz and displayed there. They are available as digital or analog output variables. The voltage is supplied externally (DC 18 to 30 V) or internally by means of four lithium batteries (size AA). The battery operating life with the recommended type of battery is one year (with default settings and one sensor).

The electronics of the measuring probe with backlit LCD display and operating keys are encased in a wall-mounted case (protection type IP65). The ambient temperature range of the measuring probe is -30 to +80 °C, but the differing ambient temperatures of the sensors and lithium batteries must also be considered. The measuring probe can be configured using the USB interface or the operating keys.

## 1.3 Block diagram

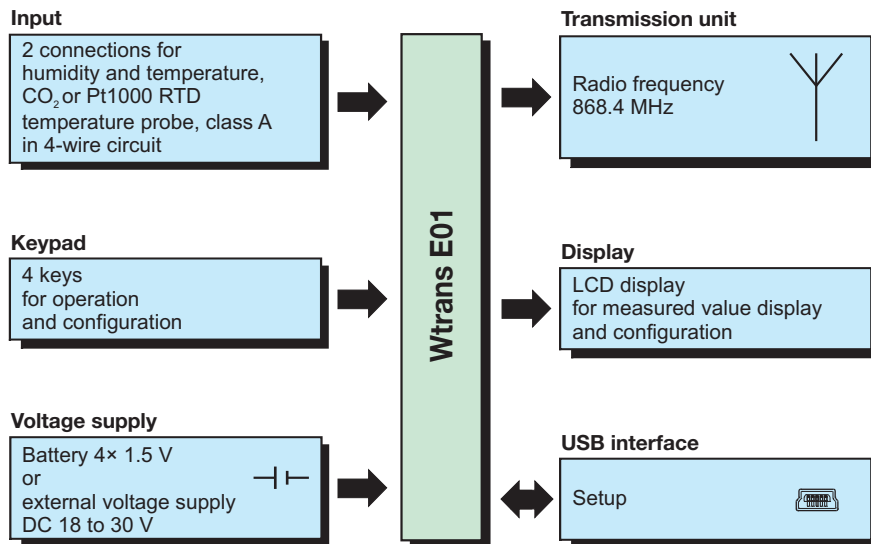

## 1.4 Connection elements

### 1.4.1 View from below

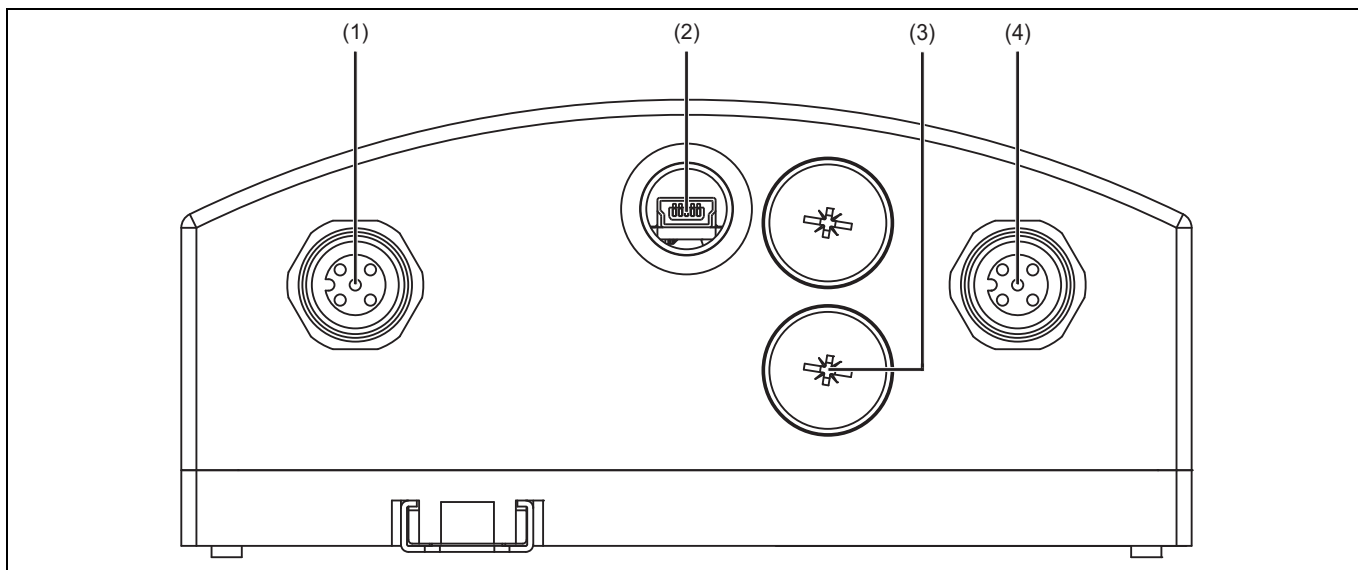

- (1) Connection for sensor 1: sensor for humidity and temperature, sensor for CO<sub>2</sub>, or RTD temperature probe Pt1000
- (2) Connection for USB connector (Mini-B): if the interface is not needed or after a configuration, the opening on the device must be sealed using the sealing screw M12 × 1.5 supplied (accessories set) with the help of the mounting key (accessories set).
- (3) Connection for external voltage supply: if the voltage is supplied externally, the cable fitting supplied (accessories set) must be used instead of the M12 × 1.5 sealing screw. Install the cable fitting instead of the sealing screw labeled with (3).
- (4) Connection for sensor 2: sensor for humidity and temperature, sensor for CO<sub>2</sub>, or RTD temperature probe Pt1000

### 1.4.2 View from above

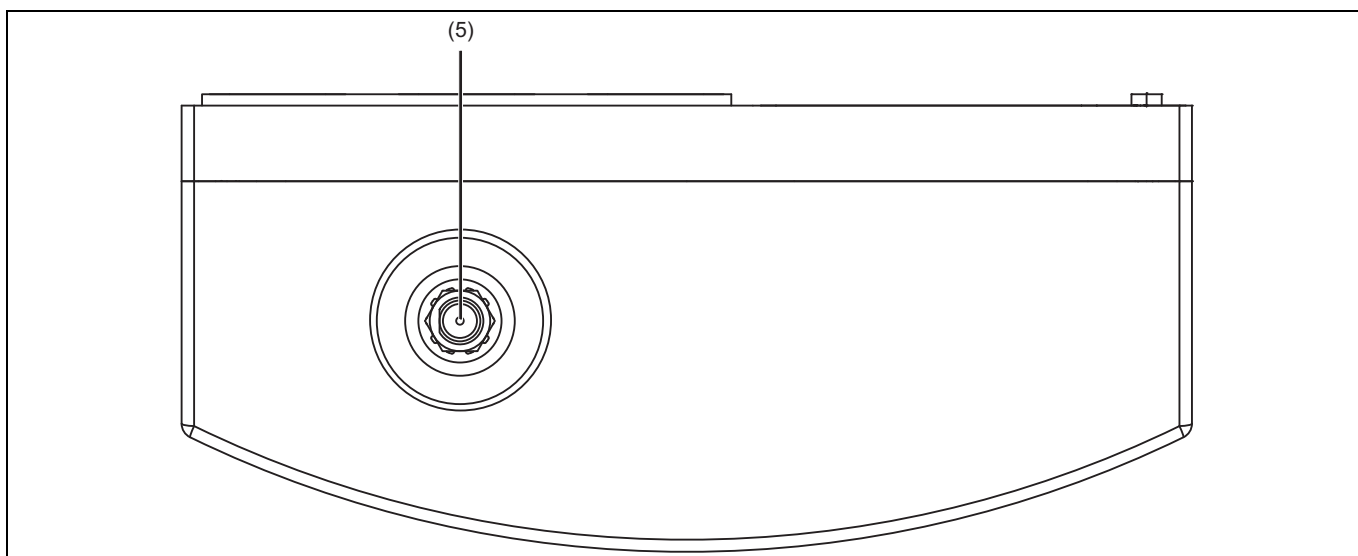

- (5) Connection for lambda/4 antenna, or optionally lambda/4 antenna with antenna cable and antenna holder for wall mounting

# 1 Introduction

---

## 1.4.3 Rear view

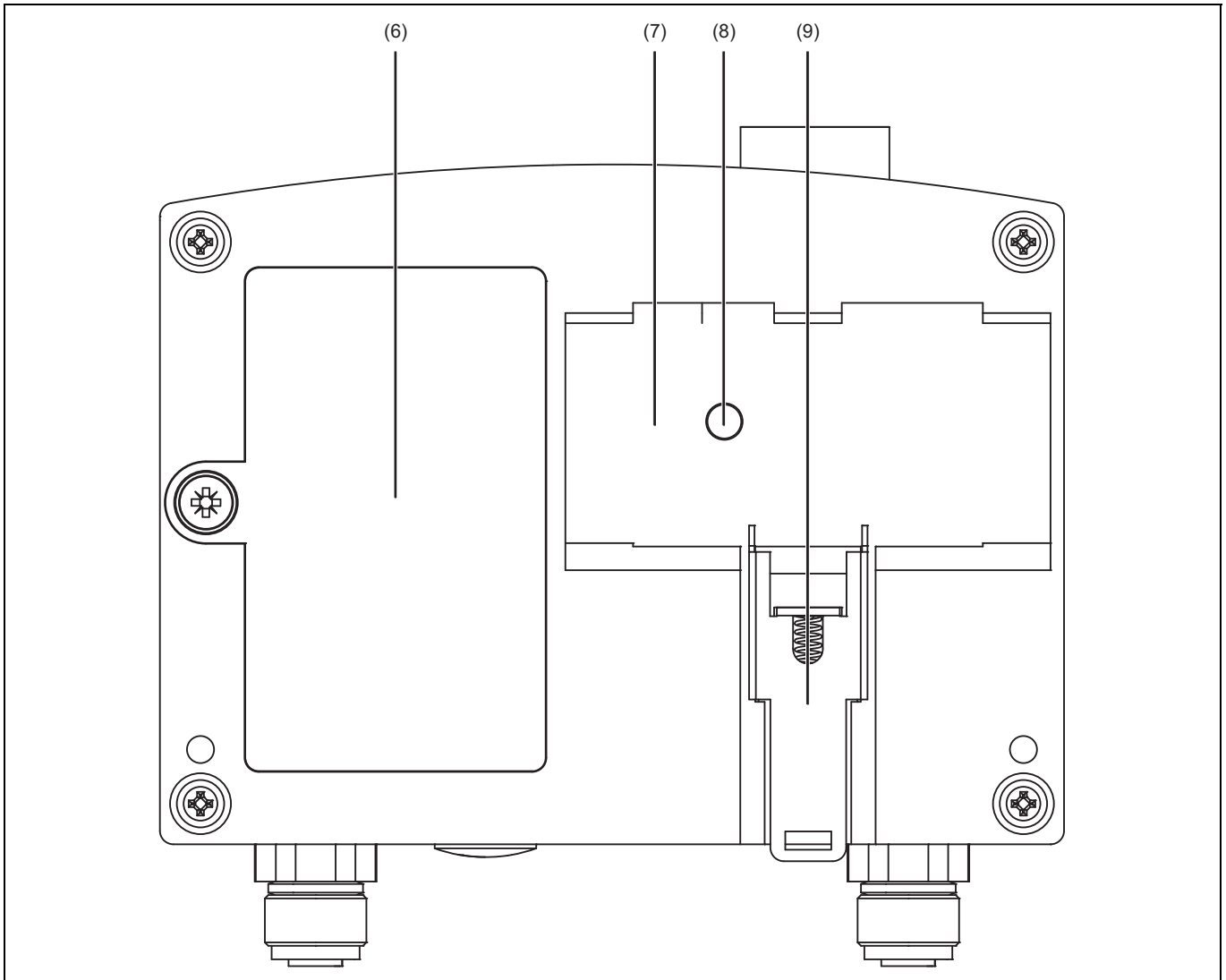

- (6) Battery compartment for inserting batteries and connecting to external voltage supply
- (7) Recess for DIN rail for mounting the case
- (8) Pressure compensation element (do not tape)
- (9) Unlocking to release the device from the DIN rail

## 1.5 Dimensions

### 1.5.1 Measuring probe

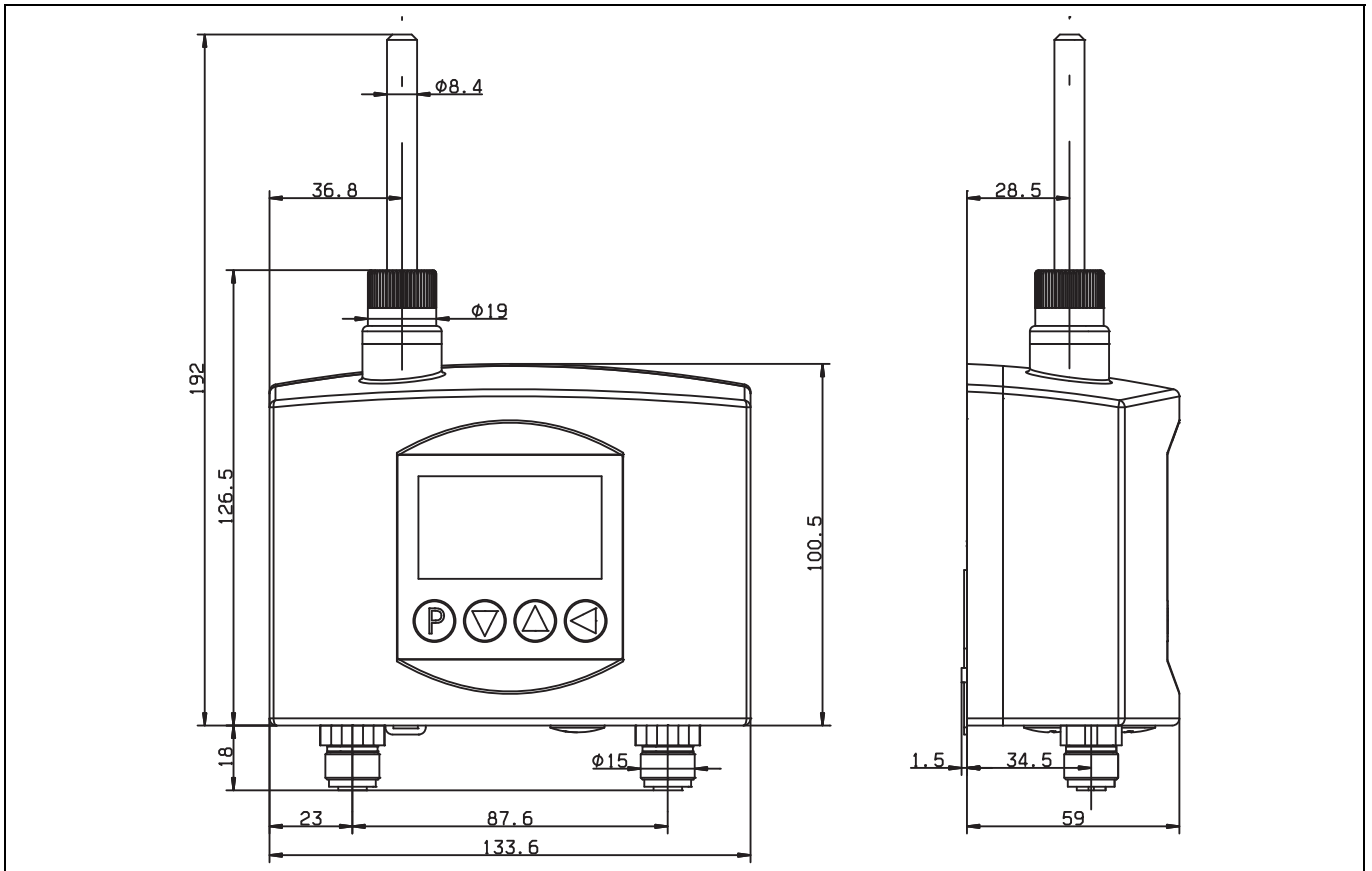

### 1.5.2 Sensors and lambda/4 antenna

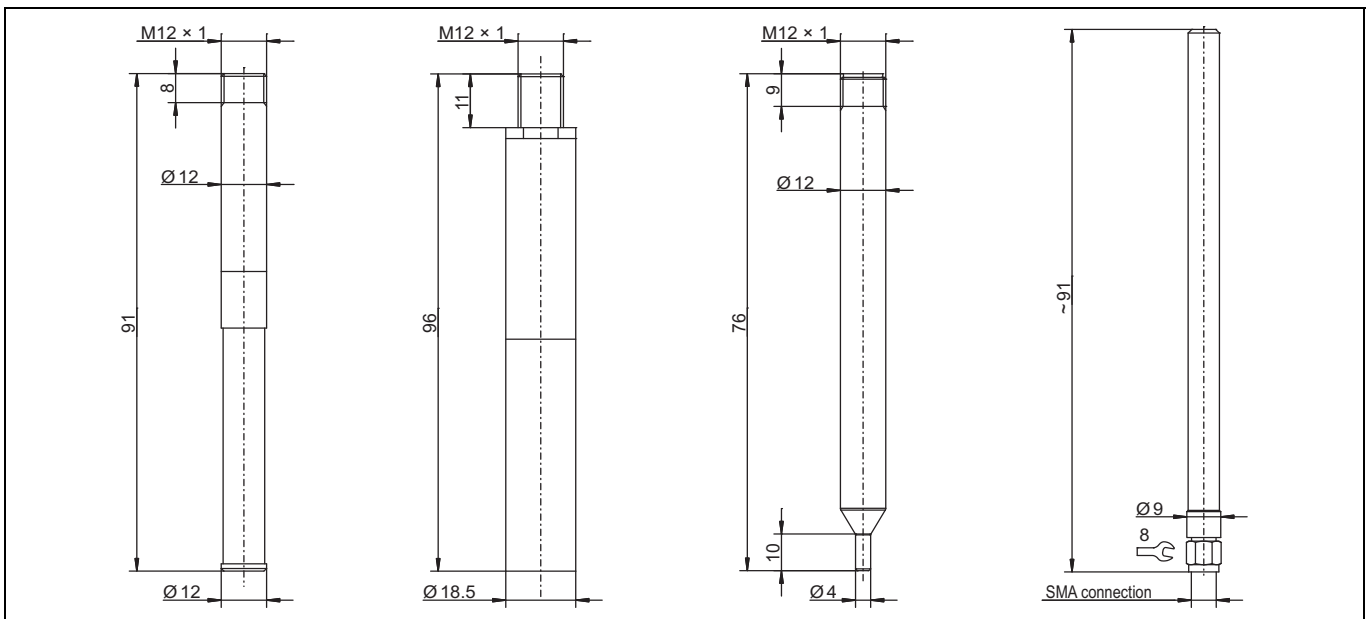

Sensor for humidity and temperature, and CO<sub>2</sub>, RTD temperature probe Pt1000, and lambda/4 antenna (from left to right)

# 1 Introduction

---

## 1.6 Declaration of conformity



### NOTE!

Hereby JUMO GmbH & Co. KG declares that the radio equipment type Wtrans E01 is in compliance with Directive 2014/53/EU. The full text of the EU declaration of conformity is available at the following Internet address: [qr-902928-en.jumo.info](http://qr-902928-en.jumo.info)

---



[qr-902928-en.jumo.info](http://qr-902928-en.jumo.info)

## 2 Identifying the device version

### 2.1 Nameplate

#### Position

The nameplate is affixed to the back cover of the device.

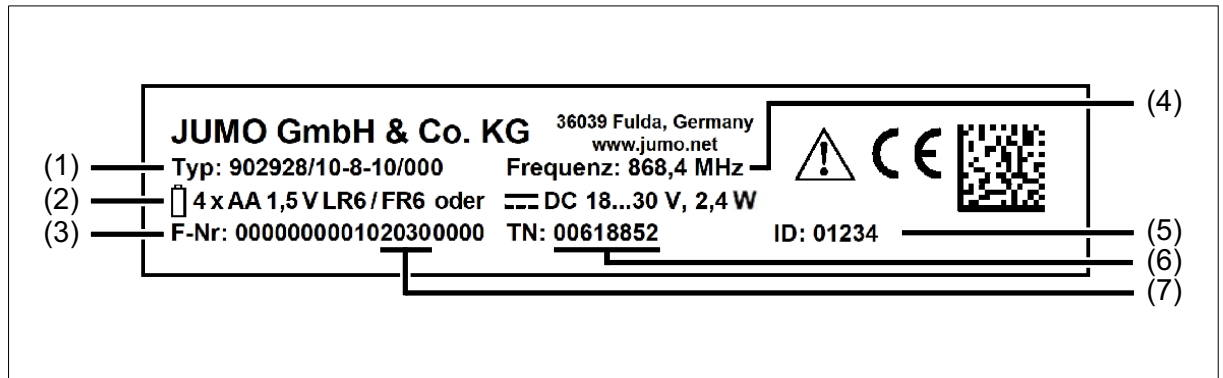

- (1) Device type
- (2) Voltage supply (— DC Symbol for direct voltage)
- (3) Fabrication number
- (4) Radio frequency
- (5) Transmitter detection (transmitter ID)
- (6) Part no.
- (7) Date of manufacture 2030 = 2020/30 (year/calendar week)

#### Device type

Compare the specifications on the nameplate with your order documents. The supplied device version can be identified using the order code in chapter 2.2 "Order details", Page 14.

#### Part no.

The part no. uniquely identifies an article in the catalog. It is important for communication between the customer and the sales department.

#### Fabrication number

Among other things, the fabrication number indicates the date of manufacture (year/calendar week) and the version number of the hardware.

#### Date of manufacture

Example: fabrication number = 00000000010**2030**00000

The characters in question are digits 12, 13, 14, and 15 (from the left).

The device was produced in the 30th calendar week of 2020.

#### Radio frequency

The radio frequency identifies the frequency used by the device for transmission. In the 868 MHz band (Europe), the transmission is carried out at 868.4 MHz.

#### Transmitter detection (transmitter ID)

The transmitter ID is a default setting. It must be entered and activated on the receiver to establish a connection between the transmitter and receiver. The transmitter ID can be changed to customer-specific requirements using the setup program. The user must ensure that several transmitters with identical transmitter IDs are not active.

## 2 Identifying the device version

### 2.2 Order details

<b>(1) Basic type</b>	
902928/10	Wtrans E01 Measuring probe for humidity, temperature, and CO <sub>2</sub> with wireless data transmission
<b>(2) Version</b>	
8	Standard with default settings
9	Customer-specific configuration (specification in plain text) <sup>a</sup>
<b>(3) Parameters</b>	
10	Humidity, temperature, and CO <sub>2</sub> (standard)
20	Activation of other parameters (absolute humidity (a), enthalpy (h), wet-bulb temperature (Tw), mixing ratio (x), dew point temperature (Td), and steam pressure (pw))
<b>(4) Extra code</b>	
000	Without

<sup>a</sup> The customer-specific configuration only applies to the transmission interval (depends on the sensor connected and RTD temperature probe Pt1000) and offset. Sensor for humidity and temperature (5 to 3600 s, per default 90 s), sensor for CO<sub>2</sub> (30 to 3600 s, per default 1200 s), RTD temperature probe Pt1000 (1 to 3600 s, per default 15 s), offset (-99.9 to +99.9, per default 0). Transmission interval and offset can also be set using the setup program (see accessories).

	<b>(1)</b>		<b>(2)</b>		<b>(3)</b>		<b>(4)</b>
<b>Order code</b>		-		-		/	
<b>Order example</b>	902928/10	-	8	-	10	/	000

### 2.3 Scope of delivery

1 device in the ordered version (sensors for humidity, temperature and CO <sub>2</sub> must be ordered separately, see accessories)
1 lambda/4 antenna, impedance 50 ohm, 868.4 MHz, T <sub>max.</sub> 125 °C
4× 1.5 V lithium batteries (size AA) in blister packaging
1 battery case for 4× 1.5 V batteries (size AA)
1 spring-cage terminal for DC 18 to 30 V external voltage supply, SELV voltage
2 accessories sets
1 operating manual

## 2 Identifying the device version

### 2.4 Accessories

Description	Part no.
Setup program on CD-ROM, multilingual <sup>a</sup>	00488887
Setup program incl. OnlineChart on CD-ROM, multilingual <sup>a</sup>	00549067
OnlineChart activation	00549188
USB cable, type A USB connector on Mini-B USB connector, length 3 m <sup>a</sup>	00506252
Lambda/4 antenna, impedance 50 ohm, 868.4 MHz, T <sub>max.</sub> 125 °C	00503151
Antenna holder for wall mounting with antipole for lambda/4 antenna	00482648
Antenna cable with preconfigured screw-type connection, length 3 m, T <sub>max.</sub> 85 °C	00601189
Antenna cable with preconfigured screw-type connection, length 5 m, T <sub>max.</sub> 85 °C	00601190
Antenna cable with preconfigured screw-type connection, length 10 m, T <sub>max.</sub> 125 °C	00669026
4× 1.5 V lithium batteries (size AA) in blister packaging	00617446
1 battery case for 4× 1.5 V batteries (battery size AA)	00606043
Spring-cage terminal for DC 18 to 30 V external voltage supply, SELV voltage	00598340
Plug-in power supply unit Voltage supply: AC 100 to 240 V, 50 to 60 Hz Output: DC 24 V, 0.5 A Ambient temperature range: 0 to 40 °C	00619184
Sensor for humidity and temperature, measuring range 0 to 100 % RH and -40 to +80 °C For connecting directly Protection tube diameter 12 mm, length 91 mm	00614528
Sensor for CO <sub>2</sub> , measuring range 0 to 2000 ppm For connecting directly Protection tube diameter 18.5 mm, length 96 mm	00614530
Sensor for CO <sub>2</sub> , measuring range 0 to 5000 ppm For connecting directly Protection tube diameter 18.5 mm, length 96 mm	00614531
Sensor for CO <sub>2</sub> , measuring range 0 to 10,000 ppm For connecting directly Protection tube diameter 18.5 mm, length 96 mm	00614532
RTD temperature probe with Pt1000 temperature sensor and machine connector M12 × 1 For connecting directly Protection tube diameter 12 mm, reduced to 4 mm, length 76 mm	00606033
Push-in RTD temperature probe with Pt1000 temperature sensor and machine connector M12 × 1 902150/99-386-1013-2-6-100-56-2500/315 Protection tube diameter 6 mm, insertion length 100 mm, connecting cable length 2500 mm	00551310
Push-in RTD temperature probe with Pt1000 temperature sensor and machine connector M12 × 1 902150/99-386-1013-2-6-200-56-2500/315 Protection tube diameter 6 mm, insertion length 200 mm, connecting cable length 2500 mm	00551311
Screw-in RTD temperature probe without transmitter with Pt1000 temperature sensor and machine connector M12 × 1 902815/10-380-1013-2-6-100-000-24/000 Protection tube diameter 6 mm, insertion length 100 mm	00511233

## 2 Identifying the device version

---

Description	Part no.
Compression fitting G 1/2 (stainless steel) for protection tube diameter 6 mm	00305445
Compression fitting G 1/2 (stainless steel) for protection tube diameter 12 mm	00312448
Compression fitting M20 × 1.5 (stainless steel) for protection tube diameter 12 mm	00558447
Cable fitting M20 × 1.5 (nickel-plated brass)	00575665
Holder for wall mounting for RTD temperature probe Pt1000 with plug connection M12 × 1	00503329
Holder for wall mounting for RTD temperature probe Pt1000 with protection tube diameter 6 mm	00503328
PUR <sup>b</sup> extension cable (shielded) with machine connector M12 × 1, length 2000 mm	00503577
PUR <sup>b</sup> extension cable (shielded) with M12 × 1 machine connector, length 5000 mm	00503578
PUR <sup>b</sup> extension cable (shielded) with M12 × 1 machine connector, length 10,000 mm	00503579
<b>Note:</b> for compression fittings and flanges refer to data sheet 909750	

<sup>a</sup> Configuration using a laptop/PC is only possible with the USB cable and one of the two setup programs.

<sup>b</sup> Polyurethane

## 3 Preparing the measuring probe

---



### CAUTION!

#### Explosion of the batteries or fire hazard.

Supply is either via batteries or external voltage supply.

- u Simultaneous supply via batteries and external voltage supply not possible.
- 

### 3.1 Receiver software version



#### NOTE!

The measuring probe requires a receiver with a software version (firmware) of 05.01 or higher.

---

### 3.2 Supply with batteries

#### 3.2.1 Inserting/changing the battery



### CAUTION!

#### Make sure that pollutants, moisture, and steam cannot enter the measuring probe.

The measuring probe could be destroyed.

- u When inserting/changing the batteries make sure that the measuring probe is not exposed to pollutants, moisture, and steam. In addition, it must be ensured that the seal is correctly fitted between the battery compartment and measuring probe.
- 



### CAUTION!

#### The measuring probe does not function if the poles of the batteries are incorrectly connected.

The transmitter's batteries and electronics could become damaged.

- u Make sure that the poles of the batteries are correctly connected.
- 



### CAUTION!

#### Incorrect batteries put safety at risk.

The measuring probe may be destroyed if incorrect batteries are used.

- u It is preferable that you only use the lithium batteries recommended as accessories.
- 



### CAUTION!

#### Electrostatic discharge

The measuring probe is fitted with electronic components that may be destroyed by electrostatic discharge.

- u When opening the measuring probe to change the battery or connect the external voltage supply, it must be ensured that the personnel are sufficiently electrostatically discharged.
-

## 3 Preparing the measuring probe

---



### CAUTION!

#### Incorrect battery setting (default setting: lithium)

If the setting of the battery type does not correspond to the type of battery used, this leads to significant loss of battery operating life or to malfunction of the low battery detection.

- u Make sure the setting on the measuring probe or setup program is correct.
- 



### NOTE!

A mixed operation of alkaline and lithium batteries can also result in the abovementioned faults. Always use batteries of the same type and charge.

---



### CAUTION!

#### Possible data loss

If measuring and transmission intervals are selected that are quicker than the default settings (especially in the case of 2 sensors), this will shorten the battery operating life, which leads to shorter alarm times between battery low and battery empty (only hours in extreme cases). In the worst case, the alarm time is approx. 2 % of the battery operating life calculated by the calculation program.

---

For the voltage supply of the measuring probe, 4 × FR6 or LR6 1.5V AA batteries are required. Lithium batteries and alkaline batteries are admissible. The battery operating life depends on the sensors used (type and number), the selected measuring and transmission intervals, the ambient temperature, and the battery type. Recommended lithium battery: Energizer Ultimate Lithium AA-L91-FR6-1.5V (this type of battery is part of the measuring probe equipment).

The measuring probe has been optimized for the recommended lithium battery. The recommended battery type achieves the best results, particularly when operating CO<sub>2</sub> sensors with high peak voltage loads. On account of its high capacity, this lithium battery guarantees the maximum battery service life, even at minus temperatures.

Recommended alkaline battery type: Duracell Ultra Power AA-MX1500-LR6-1.5 V (not available as an accessory). If alkaline batteries are used, an adjustment of the measuring probe to this battery type is recommended to optimize its lower capacity and to safeguard the battery low function. This type of battery is less suited to the operation of CO<sub>2</sub> sensors. The probe can be adjusted using the operating keys or the setup program, see chapter 9.2.2 "General parameters", Page 48.



### CAUTION!

#### Battery assortment

Due to the large assortment of batteries, it cannot be guaranteed that the measuring probe will work fault-free with each type of battery commercially available.

- u Use the recommended lithium or alkaline batteries.
-

## 3 Preparing the measuring probe

If the batteries were removed or if they must be replaced, proceed as follows:

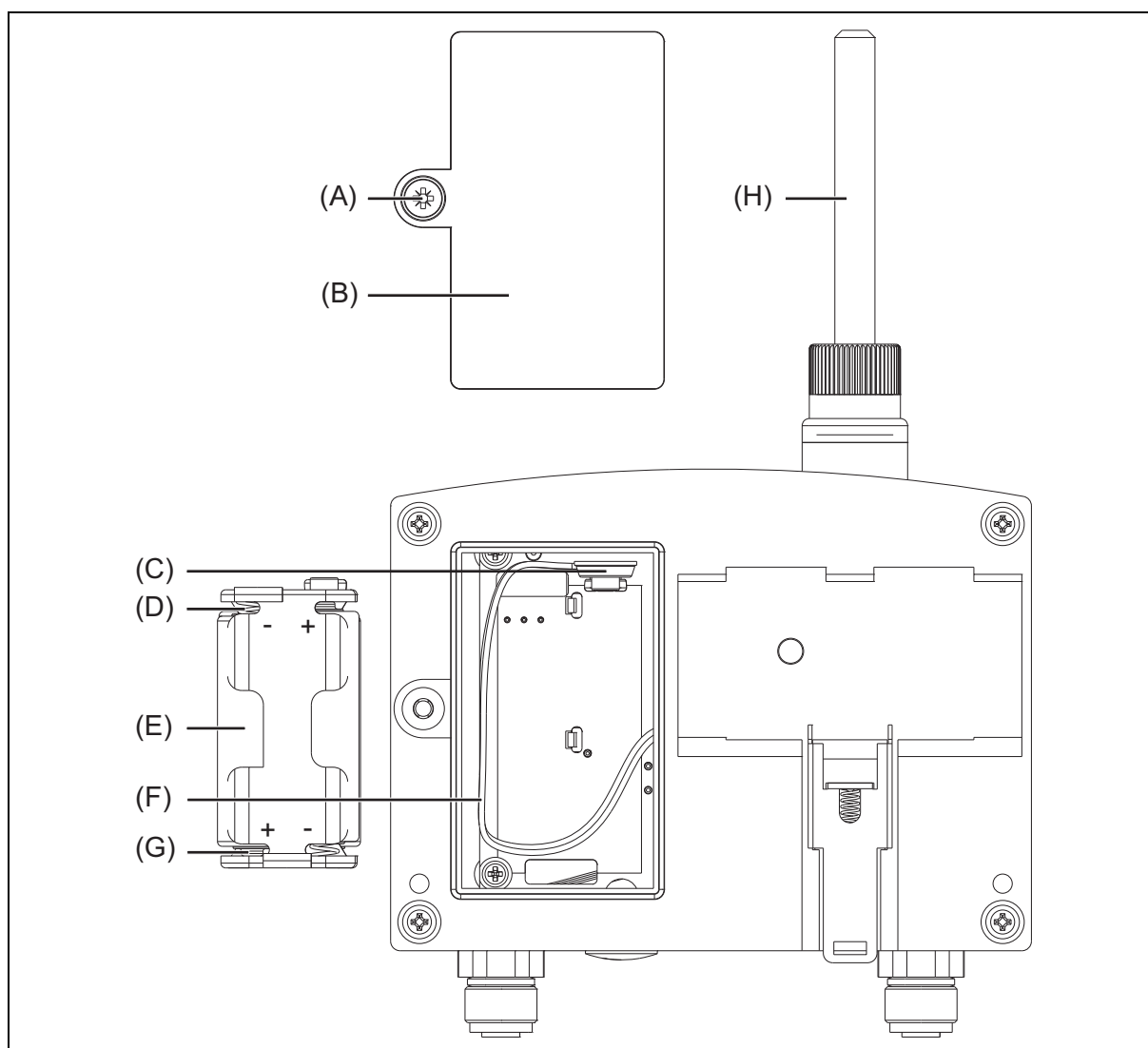

1. Unscrew screw (A) on the battery compartment cover (B) counterclockwise.
2. Remove the battery compartment cover (B) and battery case (E) from the transmitter. Remove the battery clip (C) from the battery case (E). Disconnect the internal voltage supply connection (F) and battery case from the cover (B) for the battery compartment. Remove the used batteries from the battery case (E).  
For the initial startup, the battery case is in the accessories set and not fitted to the measuring probe.
3. To insert the 4 batteries, first move the batteries up/down against the contact spring (D) of the negative pole and then connect the positive pole (G). Make the sure the polarity (+ and -) is correct!
4. Fit the battery case (E) and voltage supply connection (F) in the cover (B) for the battery compartment. Connect the battery clip (C) with the battery case (E). Insert the cover (B) on the transmitter. Make sure that the internal voltage supply connection is not damaged by pinching or bending!
5. Tighten the screw (A) clockwise on the battery compartment cover (B) (max. 1 Nm).
6. Fit the antenna (H), see chapter 3.4.1 "Installing the antenna", Page 23.  
For the initial startup, the antenna is in the accessories set and not fitted to the measuring probe.

### 3.2.2 Safety information concerning lithium batteries

⇒ <http://battery-e.jumo.info>

## 3 Preparing the measuring probe

---

### 3.2.3 Battery operating life

The expected battery operating life can be determined with the calculation program in the setup program (accessories) or with a 30-day test version (free) for lithium and alkaline batteries.

The battery operating life can only be calculated with fixed configured measurands in measured values 1 to 4. The operating life cannot be calculated with automatic sensor detection.

The low bat alarm time is approximately 2 % of the calculated battery life.

The measuring probe's battery operating life is calculated for room temperature and depends on the battery type, sensor type, transmission interval, measuring interval, and ambient temperature.

Operating the probe at the limit of the battery's admissible ambient temperature or in environments with frequent temperature fluctuations can reduce the batteries' actual operating life by up to 50 %.

Leaving the backlight switched on permanently reduces the battery operating life to a few days.

### 3.2.4 Disposal of batteries

Please dispose of all batteries as specified by the legislator according to the German Closed Substance Cycle and Waste Management Act or local regulations.

The contacts of batteries that are not fully discharged electrically need to be insulated. Disposal of batteries together with domestic waste is expressly prohibited. Batteries can be taken to municipal waste collection points or local retailers at no extra charge.

## 3 Preparing the measuring probe

### 3.3 Supply with external voltage supply



#### CAUTION!

Only a SELV voltage is admissible for external voltage supply DC 18 to 30 V. The device must be equipped with an electrical circuit that meets the requirements of EN 61010-1 with regard to "Limited-energy circuits".

If the measuring probe is connected to an external voltage supply (DC 18 to 30 V, SELV voltage), proceed as follows:

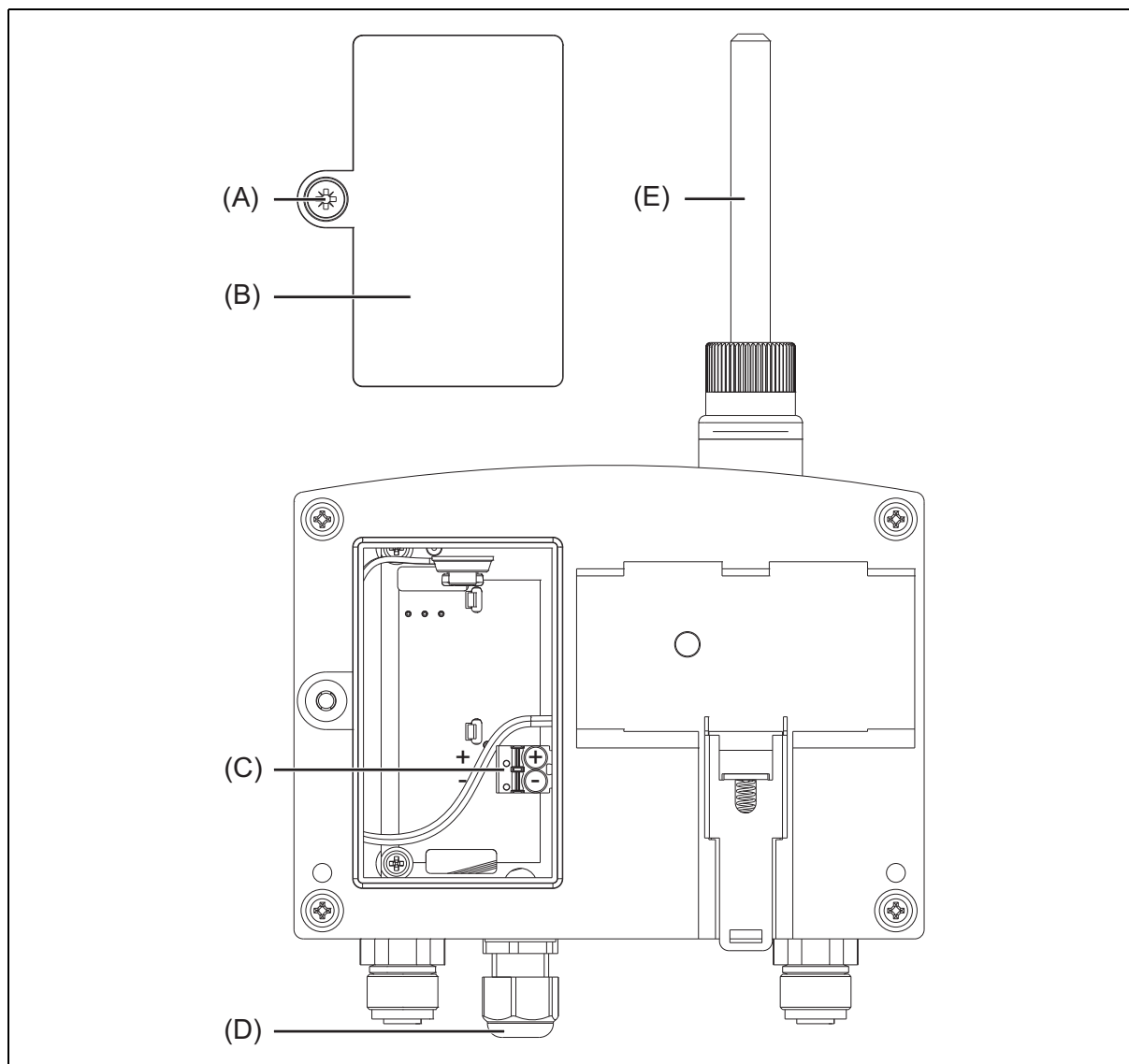

1. Unscrew screw (A) on the battery compartment cover (B) counterclockwise.
2. Remove the spring-cage terminal (C), cable fitting (D), and O-ring 11 × 1.5 mm from the accessories set.
3. Insert the spring-cage terminal (C) onto the circuit board's two connection pins.  
For the initial startup, the spring-cage terminal is in the accessories set and not fitted to the measuring probe.

### 3 Preparing the measuring probe

---

4. Unscrew the sealing screw M12 × 1.5, replace the cable fitting (D) with O-ring 11 × 1.5 mm, and tighten on the measuring probe (max. 1 Nm).  
For the initial startup, the cable fitting with O-ring is in the accessories set and not fitted to the measuring probe.
5. Guide the external voltage supply connection out through the cable fitting (D) and connect to the spring-cage terminal (C). Make the sure the polarity (+ and -) is correct!
6. Manually tighten the union nut of the cable fitting (D). Place the battery compartment cover (B) on the measuring probe. Make sure that the external voltage supply connection is not damaged by pinching or bending!
7. Tighten the screw (A) clockwise on the battery compartment cover (B) (max. 1 Nm).
8. Fit the antenna (E), see chapter 3.4.1 "Installing the antenna", Page 23.  
For the initial startup, the antenna is in the accessories set and not fitted to the measuring probe.

## 3 Preparing the measuring probe

### 3.4 Antenna installation

#### 3.4.1 Installing the antenna

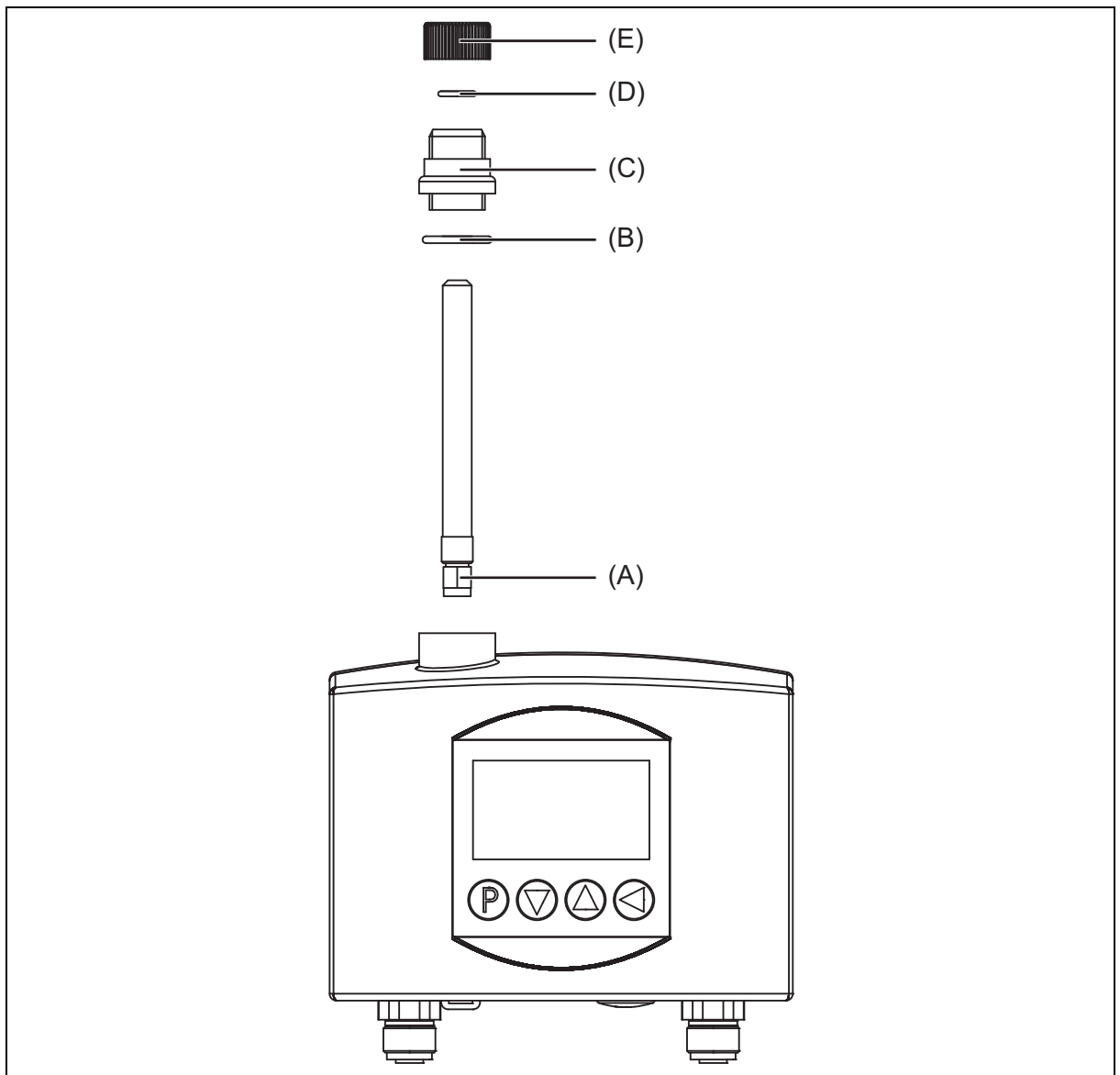

1. Screw the antenna (A) clockwise onto the transmitter (max. 1 Nm).  
For the initial startup, parts A to E are in the accessories set.
2. Insert O-ring 16 × 2 mm (B) into the recess of the protective cap (lower section) (C).
3. Screw the protective cap (lower section) (C) clockwise onto the transmitter. Make sure the O-ring (B) is positioned correctly!
4. Insert O-Ring 8 × 1.5 mm (D) onto the antenna and move it all the way down into the recess of the protective cap (lower section) (C).
5. Screw the protective cap (upper section) (E) clockwise onto the protective cap (lower section) (C). Manually tighten the protective cap (upper section) (E) onto the knurl so that there is no gap at the screw connection.

## 3 Preparing the measuring probe

### 3.4.2 Installing antenna cable

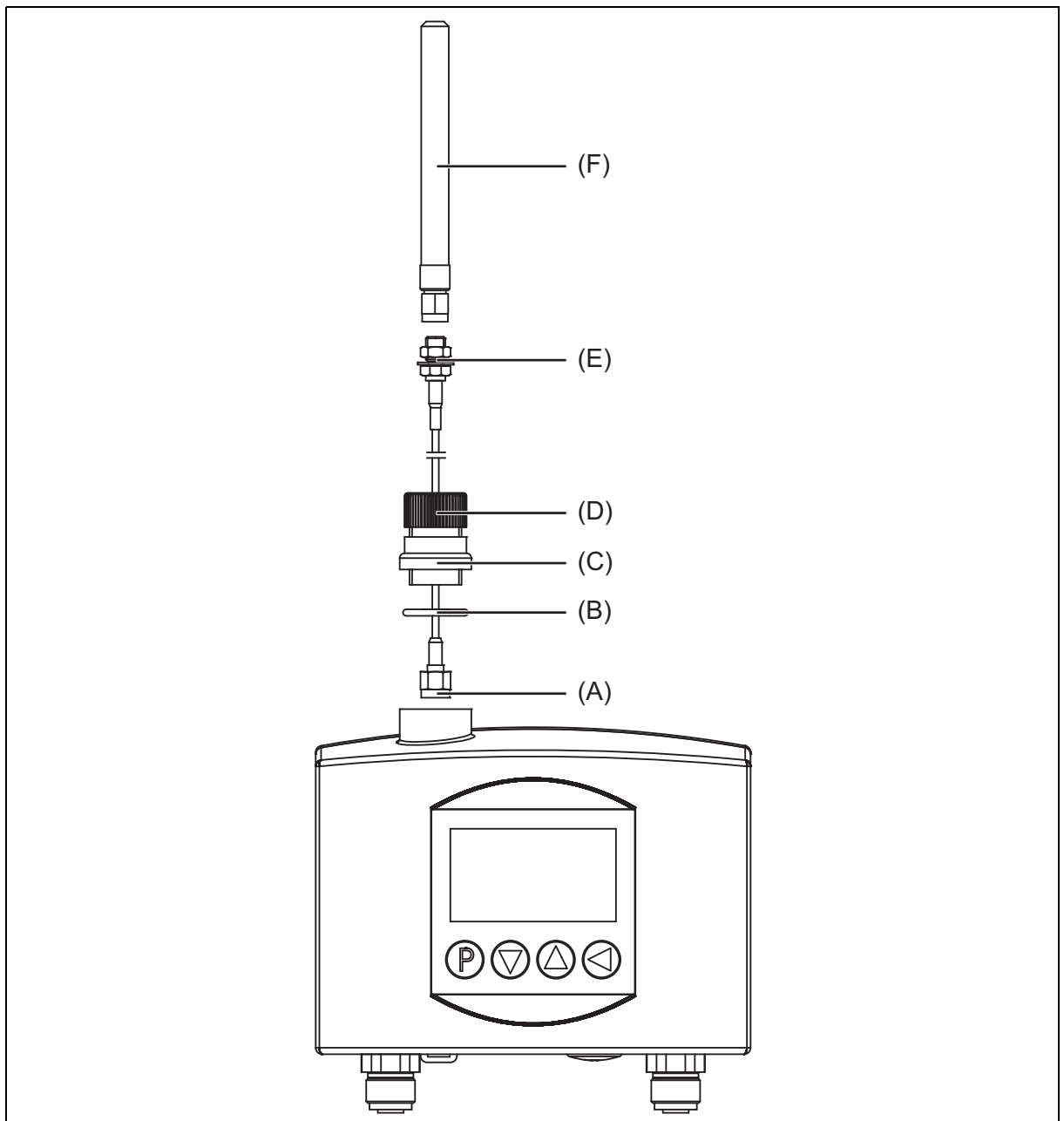

1. Screw the SMA socket (A) clockwise onto the transmitter (max. 1 Nm).  
For the initial startup, parts A to F are in the accessories set.
2. Insert O-ring 16 × 2 mm (B) into the recess of the protective cap (lower section) (C).
3. Move the protective caps (lower section (C) and upper section (D)) down onto the antenna cable. Manually tighten the protective cap (upper section) (D) onto the knurl so that there is no gap at the screw connection. Make sure the O-ring (B) is positioned correctly!
4. Install the end of the antenna cable (E) at the desired position (antenna holder for wall mounting accessories) and screw the antenna (F) clockwise onto the external thread (max. 1 Nm).

## 4.1 General information about wireless transmission

Wireless signals are electromagnetic waves whose strength becomes weaker on their path from the transmitter to the receiver (this is referred to as path attenuation). The field strength reduces at an inverse proportion to the square of the distance between the transmitter and receiver.

In addition to this natural range restriction, a reduced range may also be caused by the following:

- Reinforced concrete walls, metallic objects and surfaces, heat insulation, or heat-absorbing windows with a vapor-deposited metal layer reflect and absorb electromagnetic waves, meaning a dead spot is formed behind them.
- Metal tubes, chains, etc. on the transmitter housing; therefore, do not fasten any metallic objects to the transmitter housing.
- Insufficient spacing between several transmitters; therefore, ensure a minimum spacing of 20 cm.
- The antenna is installed at an insufficient height; therefore, install as high as possible above the ground and ensure there is a line of sight between the transmitter and receiver.

The following values are reference values concerning the permeability of wireless signals:

Material	Permeability
Wood, plaster, glass (uncoated)	90 to 100 %
Brickwork, press boards	65 to 95 %
Armored concrete (reinforced)	10 to 90 %
Metal, aluminum lamination	0 to 10 %

The range between the transmitter and the receiver in an open area is up to 300 m. Optimum reception is achieved when a line of sight can be established between the transmitter and the receiver.

If the receiver is mounted in a control cabinet or behind concrete walls or concrete ceilings, the antenna must always be installed with the holder for wall mounting and 3 m antenna cable for the receiver pointing in the direction of the transmitters.

# 4 Transmission range

## 4.2 Possible impairment of wireless transmission

### Collisions when using too many transmitters

When using a large number of transmitters, do not select a transmission interval which is too low, otherwise the radio channel will be unnecessarily occupied. A transmission interval that is too low leads to a very high data volume on the selected radio frequency, which can lead to collisions with other transmitters. The collisions can cause wireless telegrams to be destroyed during wireless transmission.

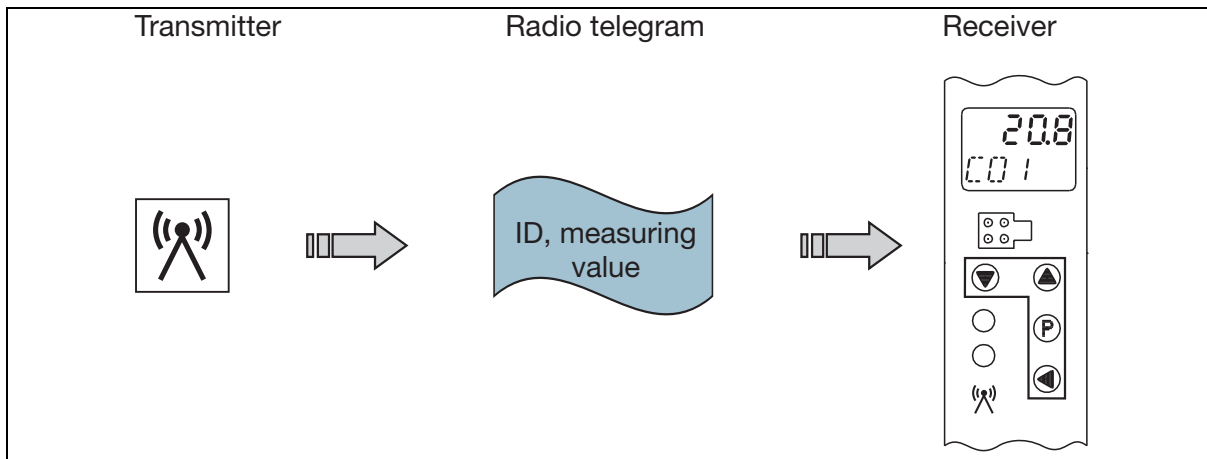

Fig. 4-1 A transmitter's wireless telegrams reach the receiver without collisions

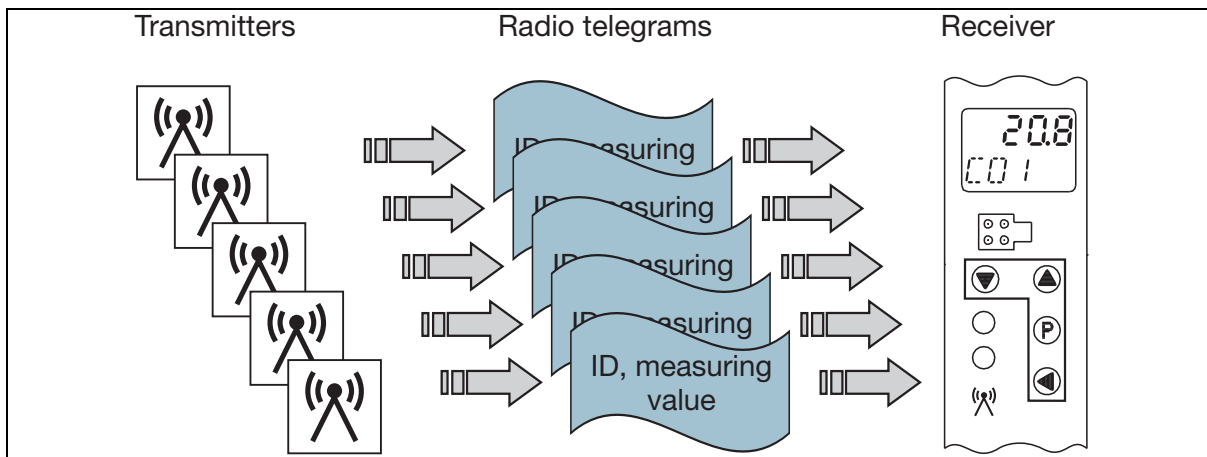

Fig. 4-2 Wireless telegrams from several transmitters may collide

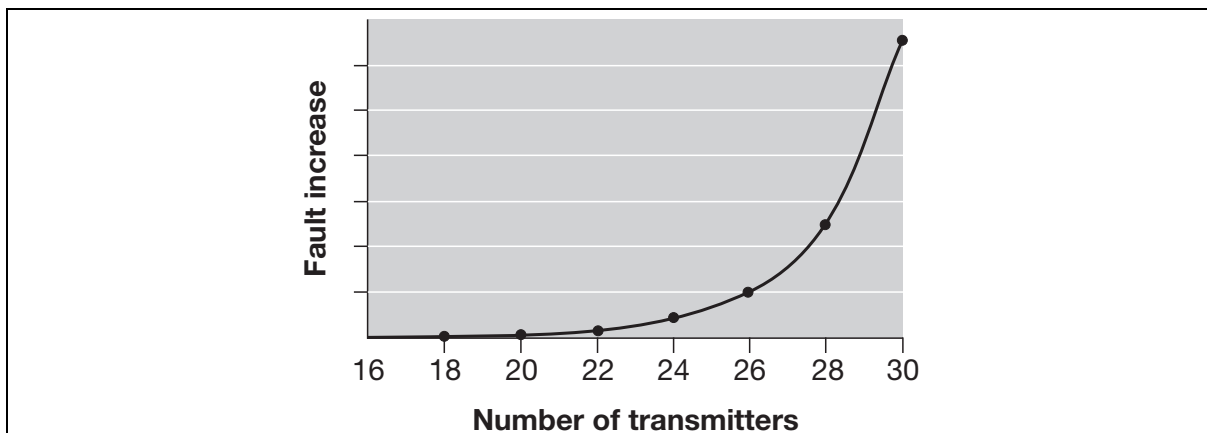

Fig. 4-3 Collisions depending on the number of transmitters with a transmission interval of 1 s

As Fig. 4-3 shows, the error curve increases sharply once there are 24 transmitters.

## 4 Transmission range

---

For this reason, we recommend using a maximum of 16 transmitters for a transmission interval of 1 s. Selecting a larger transmission interval allows for a significantly larger number of transmitters.

### Estimating the maximum number of transmitters

If more than the recommended 16 transmitters are to be used with a transmission interval of 1 s, select a higher transmission interval to prevent an increased error quota.

Example:

16 transmitters with a transmission interval of 1 s = 32 transmitters with a transmission interval of 2 s

The calculation displayed in the next example applies when the number of transmitters is to be increased further.

Example:

16 transmitters with a transmission interval of 1 s = 48 transmitters with a transmission interval of 3 s (in theory)

However, as from a transmission interval of  $\geq 3$  s, the wireless telegram is transmitted twice. This means the number of transmitters that can be used is cut in half.

16 transmitters with a transmission interval of 1 s = 24 transmitters with a transmission interval of 3 s (effective)

The same occurs with a transmission interval of  $\geq 60$  s. As of this transmission interval the wireless telegram is transmitted three times.

### External transmitters

External transmitters may transmit on the same radio frequency. If, for example, the transmitter and an external transmitter transmit their wireless telegrams at the same time, the wireless telegram is destroyed. No error is detected because the transmitters cannot check their own transmission while transmitting.

### Electrical devices

In a harsh industrial environment, wireless telegrams can be destroyed, for example, by frequency converters, electrical welding equipment, poorly-shielded laptops/PCs, audio/video devices, electronic transformers, electronic ballasts, etc.

### Error fade-out

Lost telegrams (caused either by external interference sources or by collisions when using a large number of transmitters) can be faded out at the receiver by the wireless timeout parameter and do not cause error messages. The value received last is retained over 2 to 20 transmission intervals and only then is the wireless timeout alarm activated (display "----").



#### NOTE!

In the event of collisions caused by an excessive number of transmitters, observe and, if necessary, correct the factors "number of transmitters", "transmission intervals", and, on the receiver, "wireless timeout".

---

## 4 Transmission range

---

## 5.1 Notes about mounting, arrangement, and safety



**NOTE!**

Never cover or coat the case with metallic objects. Otherwise, the measuring probe range is impaired.

---



**NOTE!**

To ensure the measuring probe functions optimally, ensure a minimum spacing of 200 mm.

---

## 5.2 Safety information



**NOTE!**

The measuring probe is not suitable for safety-critical applications.

---



**NOTE!**

The measuring probe is not suitable for installation and application in potentially explosive areas.

---



**NOTE!**

When installing and operating the measuring probe, ensure that no electrostatic charging can take place.

---



**NOTE!**

Never expose the measuring probe to magnetic or electrical fields (caused by transformers, walkie-talkies, or electrostatic discharge, for example).

---

# 5 Mounting

## 5.3 Mounting and dismounting the measuring probe

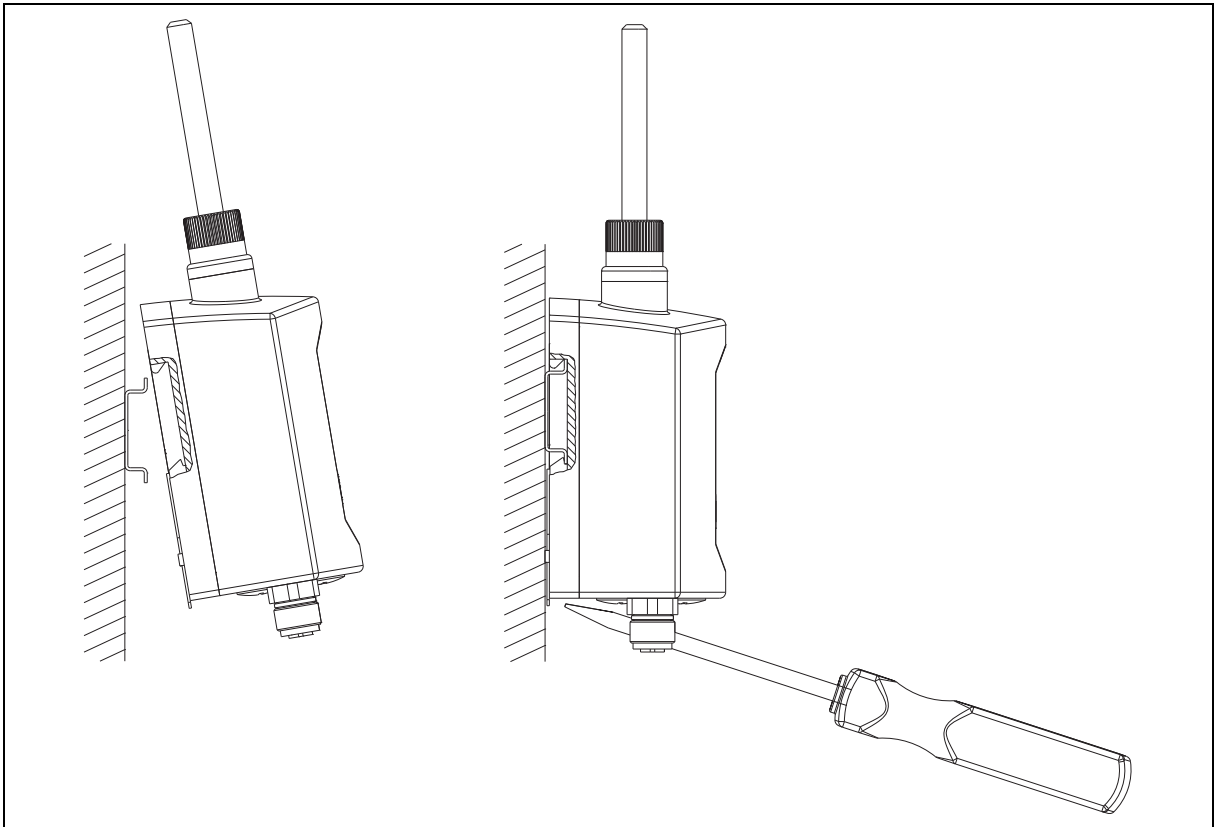

Fig. 5-1 Mounting (left) and dismounting (right) of the measuring probe

### Mount the measuring probe on the DIN rail

The measuring probe is intended for wall mounting on the DIN rail piece according to DIN EN 60715. The measuring probe is mounted and dismounted as follows:

#### Mounting

1. Hook the housing into the DIN rail from above.
2. Swing the housing downwards until it engages.

#### Dismounting

1. Insert the appropriate screwdriver into the metal foot catch and pull downwards.
2. Swing the measuring probe up and out of the DIN rail and remove.



#### NOTE!

At the mounting site, ensure a minimum clearance of 100 mm below the measuring probe to allow access to the metal foot catch for dismounting with a screwdriver. Maintain a minimum clearance of 150 mm from the top if the antenna is fitted directly on the measuring probe.

## 6.1 Installation notes

The choice of cable material, the installation, and the electrical connection of the device must conform to the requirements of VDE 0100 "Regulations on the Installation of Power Circuits with Nominal Voltages below 1000 V" or the appropriate local regulations.

The electrical connection must only be carried out by qualified personnel.

The device is intended for wall mounting.

The electromagnetic compatibility meets the standards and regulations cited in the technical data.

Probe and interface cables should be shielded cables with twisted conductors. Do not run cables close to current-carrying components or cables. Ground the shielding on one side.

Do not connect additional loads to the voltage supply cables of the device.

The device is not suitable for installation in potentially explosive areas.

In addition to a faulty installation, incorrectly set parameters may also impair the proper function of the following process or lead to damage.

## 6.2 Voltage supply

Connection	Connection element	Comment
4× 1.5 V lithium or alkaline batteries (size AA)	6	Connection in the battery compartment by inserting batteries 

or

Connection	Connection element	Comment
DC 18 to 30 V, SELV voltage	3 and 6	Connection in the battery compartment using spring-cage terminal (Drawing out of the connecting cable via the cable fitting on the underside of the case) 

## 6.3 Input

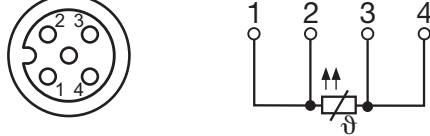
Connection	Connection element	Symbol
Sensor for humidity and temperature	1 or 4	
Sensor for CO <sub>2</sub>	1 or 4	
RTD temperature probe Pt1000 in four-wire circuit	1 or 4	

## 6 Electrical connection

---

### 6.4 Output

Connection	Connection element	Symbol
Lambda/4 antenna	5	

### 6.5 Interface

Connection	Connection element	Symbol
USB interface (Mini-B)	2	

# 7 Introduction to operation

## 7.1 Display and control elements

Operation and configuration of the measuring probe require four operating keys located at the front. These have various functions depending on the menu. The dialog is supported by an LCD display. The operation and configuration of the parameters are organized into three different levels:

- Normal display (display of measured value, measured value no., and measurand)
- Parameter level (editing of configuration parameters)
- Startup level (display of measured value, measured value no., and measurand)

The startup level differs from the normal display in that it uses a temporary fast measuring and transmission interval.

A code can be used to protect the parameter level from unauthorized access.

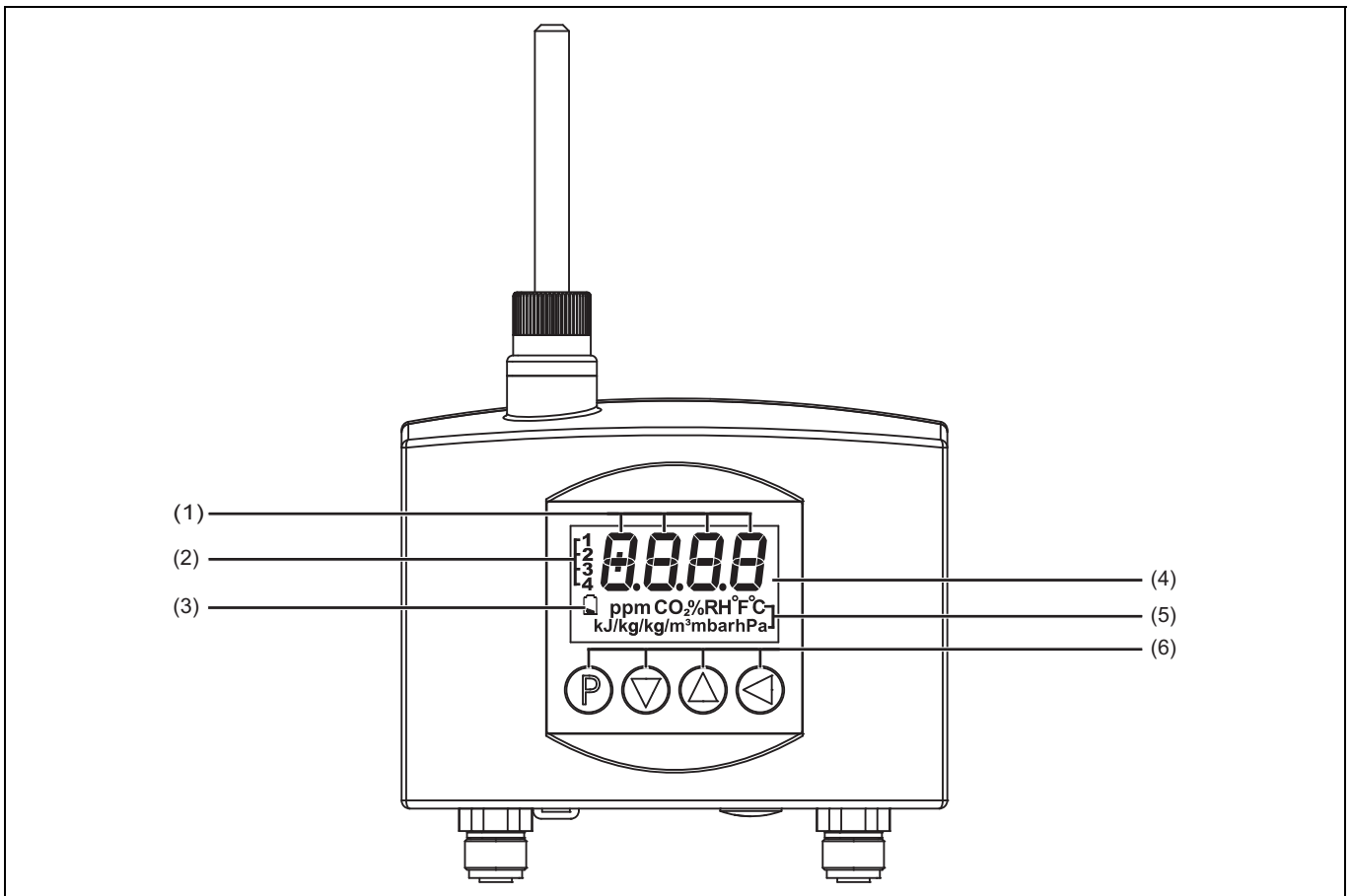

- (1) Measured value
- (2) Measured value no. (1, 2, 3, and 4)
- (3) Battery symbol (battery low/battery empty)
- (4) LCD display,  
15 mm-high 4-digit segment display and 4 mm-high symbols for measurands with white backlight
- (5) Measurands (ppm CO<sub>2</sub>, %RH, °F, °C, kJ/kg, g/kg, g/m<sup>3</sup>, mbar, and hPa)
- (6) Operating keys (P key, down key, up key, and left key)

# 7 Introduction to operation

## 7.2 Normal display (NA) (displaying measured values)

When the device is started, all segments will be activated (check LCD display). If the LCD display is switched off, the user can switch on the LCD display for at least 10 s by touching one of the four keys (LCD display switches off 10 s after the last touch of the key). The same also applies to the illumination of the LCD display (depending on configuration).

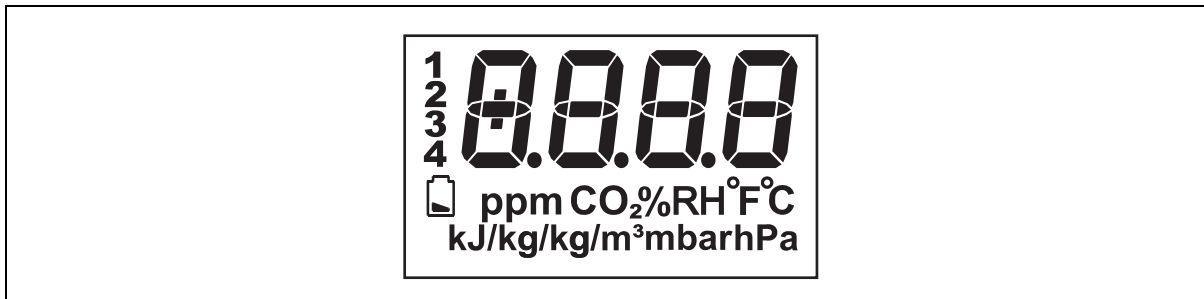

Sample appearance of measured values:

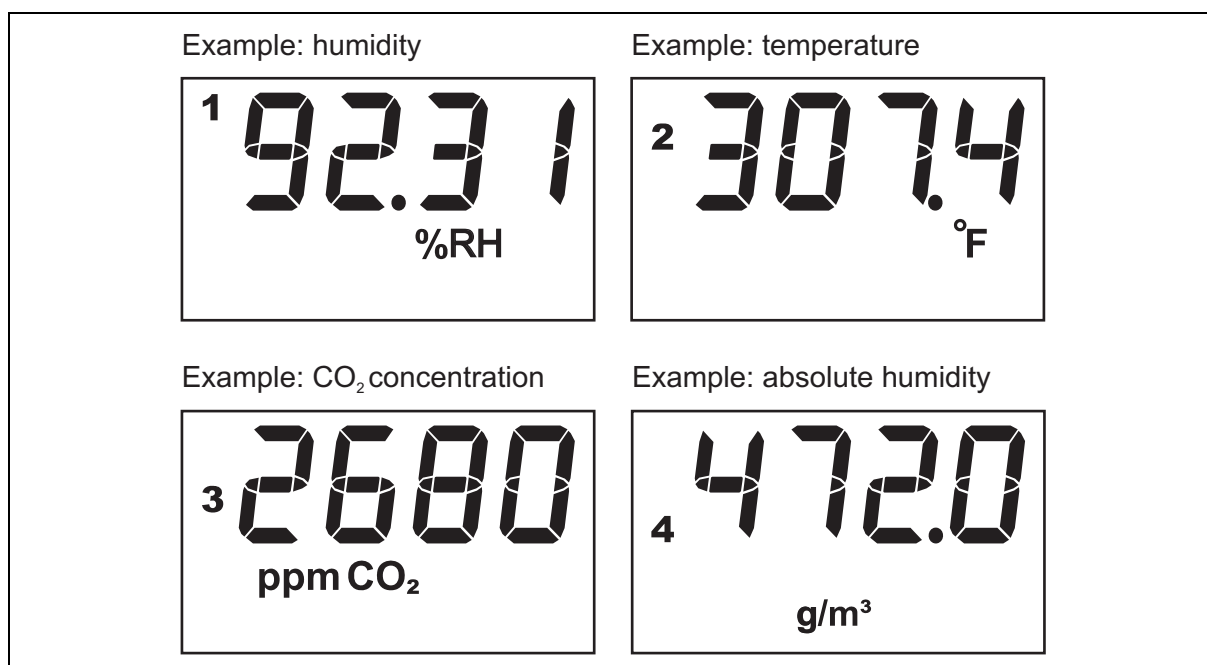

### NOTE!

If a USB connector is inserted, all measurements are carried out except the CO<sub>2</sub> measurement. The CO<sub>2</sub> measured values are "frozen" in the inserted USB connector. If no measured value is available, "- - -" is displayed on the LCD display alongside the measured value number and measurand.



### NOTE!

It is **not** possible to take a CO<sub>2</sub> measurement while a USB connector is inserted.













### NOTE!



A configuration at an ambient temperature of < -10 °C is only possible with the setup program because of the lengthy response time of the LCD display.

## 7 Introduction to operation



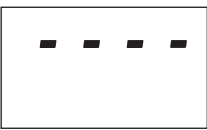
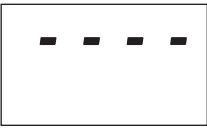

### Appearances

Display	Description
	Measured value 1 without/with decimal place
	No sensor connected
	Sensor connected, all measurands configured to "no measured value" and/or "measured value display" not activated Explanation: no.UA (no.Va) = no Value
	Ovrange
	Underrange
	Configuration does not correspond to the connected sensors or the parameters have to be activated
	Transmission failure between controller and sensor
	Sensor signals incorrect measurements
	Sensor was not connected or not recognized (message only displayed if measurand has fixed configuration).
	The measuring probe has adopted the default configuration values. The error can be reset with a configuration transfer (setup) or by configuring the measuring probe.
	Unknown error

## 7 Introduction to operation

Display	Description
	Measured value $\geq 10000$ These four dashes are also displayed if a sensor has already been recognized, but has not yet carried out a measurement.
	Measured value $\leq -1000$ These four dashes are also displayed if a sensor has already been recognized, but has not yet carried out a measurement.
	Low battery voltage: Battery symbol is displayed; measured value recording and transfer is carried out
	Empty battery: Empty battery symbol and also "bAt" displayed; measured value recording and transfer is <b>not</b> carried out; operation using key no longer possible

### Keys and key combinations

Keys	Function
 or 	Selection of measured values 1 to 4
 > 2 s	Change to the startup level
 > 2 s	Change to the parameter level

## 7.3 Startup level (In) (measuring and transmitting measured values quickly)

The startup level comes in useful if, for example, you wish to determine the optimum antenna position when mounting the device, as this level allows measured values to be "measured and sent quickly".

By changing to the startup level (In), "InbE" and the measured value of 1 are displayed alternately. In addition, the measured value number and the corresponding measurand may also appear.

The display changes after 2 minutes if none of the operating keys are pressed. Once this time has passed, it will automatically return to the normal display (NA).

The measured values are taken every 15 s and transmitted every 1 s, even with a USB connector inserted. If the configured measuring interval is less than 15 s, the shorter interval is used. At the shortest measuring interval, the CO<sub>2</sub> sensor measures every 30 s.

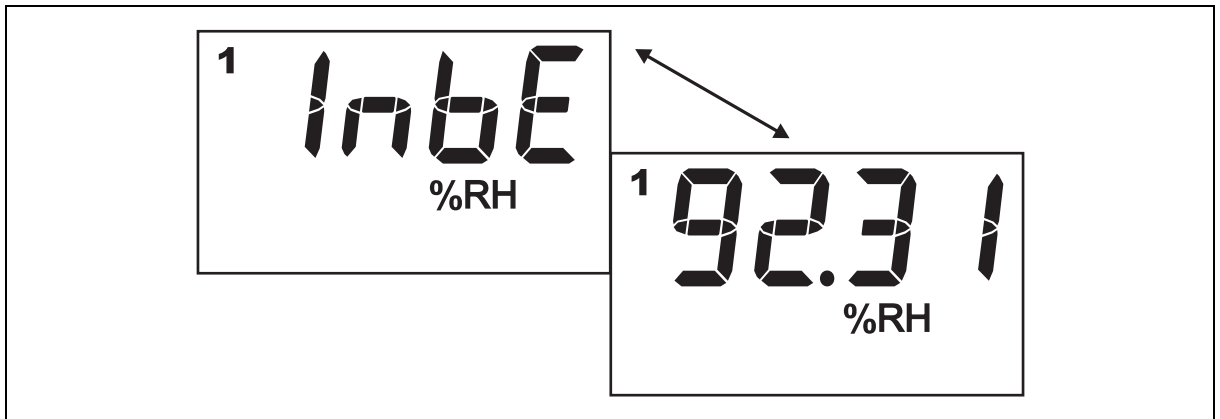

### NOTE!

If a USB connector is inserted, all measurements are carried out except the CO<sub>2</sub> measurement. The CO<sub>2</sub> measured values are "frozen" in the inserted USB connector. If no measured value is available, "- - - -" is displayed on the LCD display alongside the measured value number and measurand.



### NOTE!

It is **not** possible to take a CO<sub>2</sub> measurement while a USB connector is inserted.

### Keys and key combinations

Keys	Function
▲ or ▼	Selection of measured values 1 to 4
◀ > 2 s	Return to the normal display (NA)

# 7 Introduction to operation

## 7.4 Parameter level (PA) (configuring parameters)

By changing to the parameter level (PA), the parameter and parameter value are displayed alternately. The display changes after 40 s if none of the operating keys are pressed. Once this time has passed, it will automatically return to the normal display (NA).

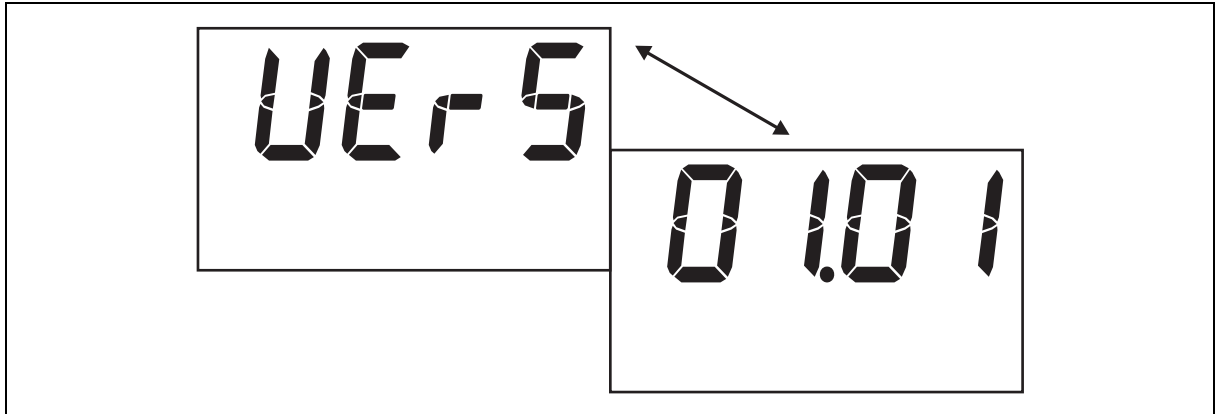

### Keys and key combinations

Keys	Function
▲ or ▼	Change to the next or previous parameter
▲ > 2 s	Change to the first parameter of the next group (general, measured value 1, 2, 3, or 4) (large jump)
▼ > 2 s	Change to the first parameter of the previous group (general, measured value 1, 2, 3, or 4) (large jump)
◀ > 2 s	Return to the normal display (NA)
P	Select the currently displayed parameter value for editing
P > 2 s	If parameter editing is selected: Save the currently displayed value in Parameter.
▲ or ▼	If parameter editing is selected: Selection of the possible parameter settings; changing of values step by step.
◀	If parameter editing is selected: Direct entry of the parameter value through digit by digit editing of the desired parameter values (only possible with numerical values!).

⇒ chapter 9.2 "Parameter level (PA)", Page 46

# 8 Operating the measuring probe

---

## On the measuring probe

Operation and configuration of the measuring probe require four operating keys located at the front. These have various functions depending on the menu. The dialog is supported by an LCD display. The operation and configuration of the parameters are organized into three different levels:

- Normal display (displaying measured values)  
⇒ chapter 8.1 "Normal display (NA)", Page 40
- Startup level (measuring and transmitting measured values quickly)  
⇒ chapter 9.1 "Startup level (In)", Page 45
- Parameter level (editing configuration parameters)  
⇒ chapter 9.2 "Parameter level (PA)", Page 46

By using a code, the parameter level can be protected from unauthorized access.

## Via setup program for laptop/PC

Configuration via the setup program is more comfortable than using the measuring probe keypad. The configuration data can be archived and printed.

- ⇒ chapter 10 "Setup program", Page 51

## 8 Operating the measuring probe

### 8.1 Normal display (NA)

The normal display is active when the measuring probe is connected via the battery or an external voltage supply.

In the normal display, a maximum of 4 measured values can be alternately displayed every 4 s (depending on configuration).

### 8.2 Displaying measured values

#### Measured values available

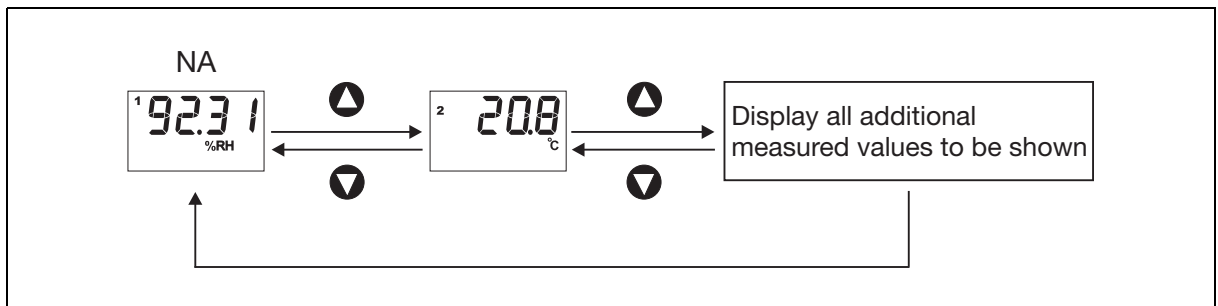

The ▲ and ▼ keys can be used to consecutively display all measured values either in an ascending or descending order.

#### No measured values available

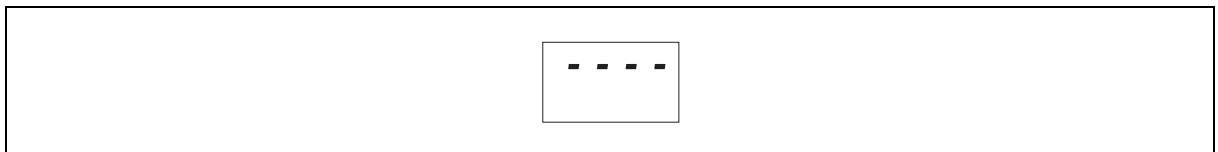

If no measured values are available, this is shown by the note "----".

# 8 Operating the measuring probe

## 8.3 Changing to different levels

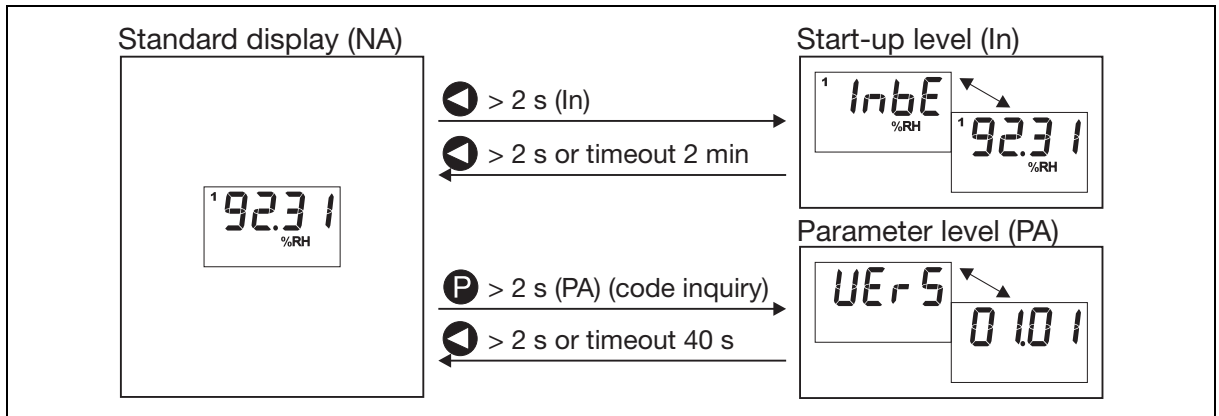

Fig. 8-1 Changing to different levels

Hold the ◀ key for > 2 s to change to the startup level (In). Here the measured values are taken every 15 s and transmitted every 1 s, even with a USB connector inserted. If the configured measuring interval is less than 15 s, the shorter interval is used. At the shortest measuring interval, the CO<sub>2</sub> sensor measures every 30 s.

Hold the P key for > 2 s to change to the parameter level (PA). All functions of the measuring probe, the general parameters of the measuring probe, and the specific parameters for the measured values are determined here.

### Key timeout

If no key is pressed in the startup level for a period of 2 min and or 40 s in the parameter level, the measuring probe automatically returns to the normal display.

### Code request

The transmitter features one code request for each change to the parameter level. However, this code request is not active when delivered. In the parameter level, a code (minimum 1 digit, maximum 4 digits) can be assigned.

⇒ chapter 8.4 "Code request", Page 42

# 8 Operating the measuring probe

## 8.4 Code request

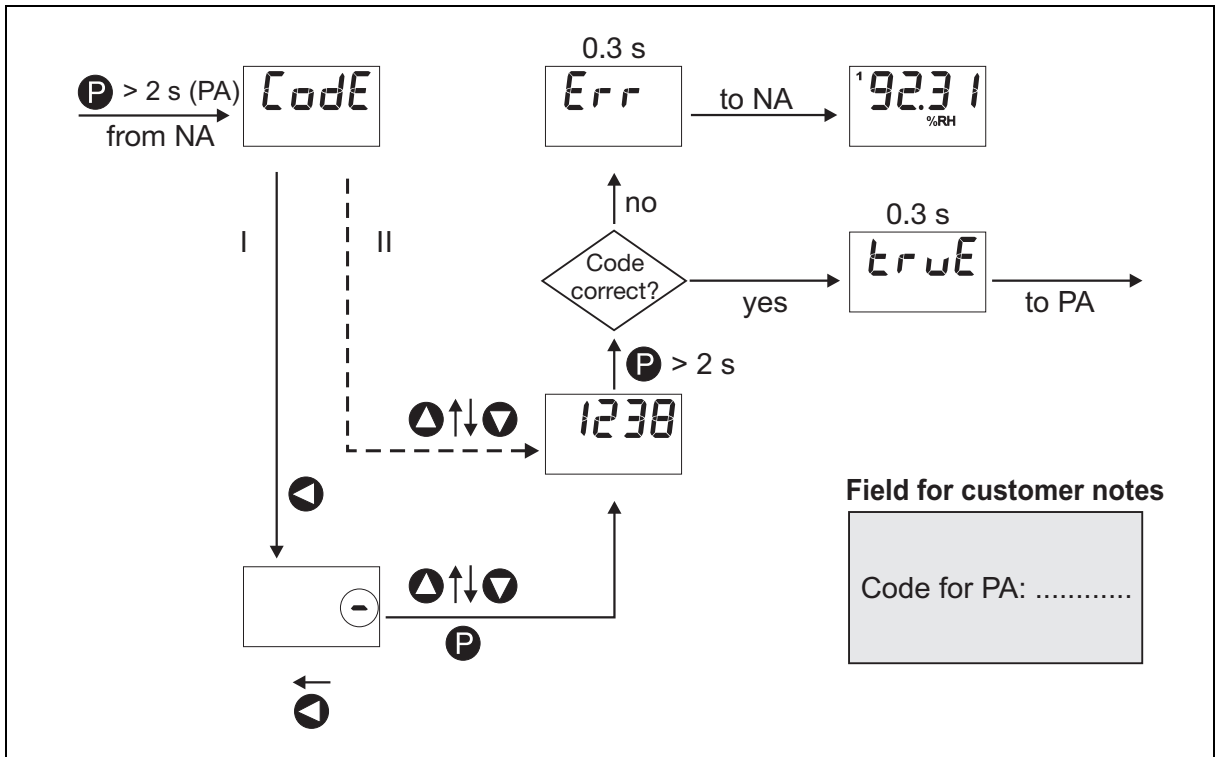

Fig. 8-2 Code request for the parameter level

The code for changing from the normal display (NA) to the parameter level (PA) can be edited either directly or digit by digit.

### Direct editing

This approach is selected if short codes are generally sufficient (see path II in Fig. 8-2).

1. Hold the **P** key for > 2 s to change from the normal display to the parameter level.  
*When a code is assigned for the parameter level, "CodE" appears on the display.  
 The device waits for a code to be entered (min. 1 digit, max. 4 digits).*
2. Edit code using keys **▲** and **▼**.
3. Confirm the code entry by pressing the **P** key for > 2 s.  
*If the code is correct, "truE" appears for 0.3 s.  
 The transmitter switches to the parameter level.  
 If the code is incorrect, "Err" appears for 0.3 s.  
 The transmitter returns to the normal display.*



### Editing digit by digit

This approach is practical if longer codes are generally required (see path I in Fig. 8-2).

1. Hold the **P** key for > 2 s to change from the normal display to the parameter level.  
*When a code is assigned for the parameter level, "CodE" appears on the display.  
 The measuring probe waits for a code to be entered (min. 1 digit, max. 4 digits).*
2. Initiate code editing by pressing the **◀** key.  
*The bottom segment of the right digit flashes.*
3. Edit digits using keys **▲** and **▼**.

## 8 Operating the measuring probe

---

4. To confirm the first digit, press the  key.  
*The bottom segment of the second digit to the right flashes.*
5. Repeat steps 3 and 4 until all digits are edited  
(min. 1 digit, max. 4 digits).
6. To confirm the code, press the  key.  
*The bottom segment of the last entered digit no longer flashes.*
7. Confirm the code entry by pressing the  key for > 2 s.  
*If the code is correct, "truE" appears for 0.3 s.  
The measuring probe switches to the parameter level.  
If the code is incorrect, "Err" appears for 0.3 s.  
The measuring probe returns to the normal display.*



### NOTE!

To deactivate, set the code for the parameter level to 0.

---

⇒ chapter 9.2.2 "General parameters", Page 48

## 8 Operating the measuring probe

---

# 9 Configuring the transmitter

## 9.1 Startup level (In)

In this level, the measured values are measured and transmitted quickly. The measured values are taken every 15 s and transmitted every second, even with a USB connector inserted. If the configured measuring interval is less than 15 s, the shorter interval is used. At the shortest measuring interval, the CO<sub>2</sub> sensor measures every 30 s.



### NOTE!

If a USB connector is inserted, all measurements are carried out except the CO<sub>2</sub> measurement. The CO<sub>2</sub> measured values are "frozen" in the inserted USB connector. If no measured value is available, "- - - -" is displayed on the LCD display alongside the measured value number and measurand.



### NOTE!

It is **not** possible to take a CO<sub>2</sub> measurement while a USB connector is inserted.

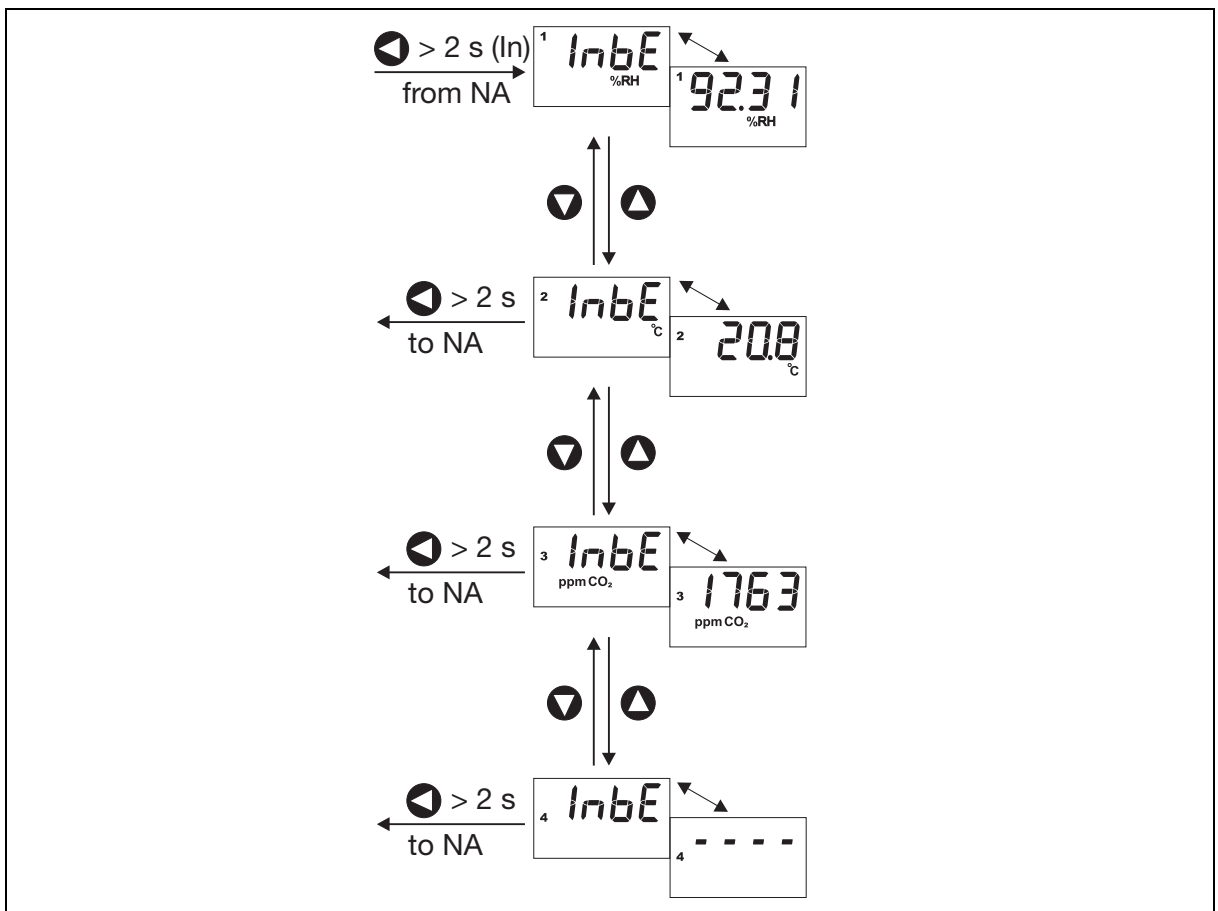

Fig. 9-1 Sample appearance for the startup level

1. Hold the key for > 2 s to change from the normal display to the startup level.  
*Startup level is activated.*
2. Select the measured values of the measuring probe using the or keys.  
*The measured values are taken every 15 s and transmitted every 1 s, even with a USB connector inserted. If the configured measuring interval is less than 15 s, the shorter interval is used. At the shortest measuring interval, the CO<sub>2</sub> sensor measures every 30 s.*
3. To return to the normal display, hold the key for > 2 s or use the 2 min key timeout.

# 9 Configuring the transmitter

## 9.2 Parameter level (PA)

This level is used to adapt the measuring probe to its task. Settings can be selected for the individual parameters or values can be entered within the default limits.

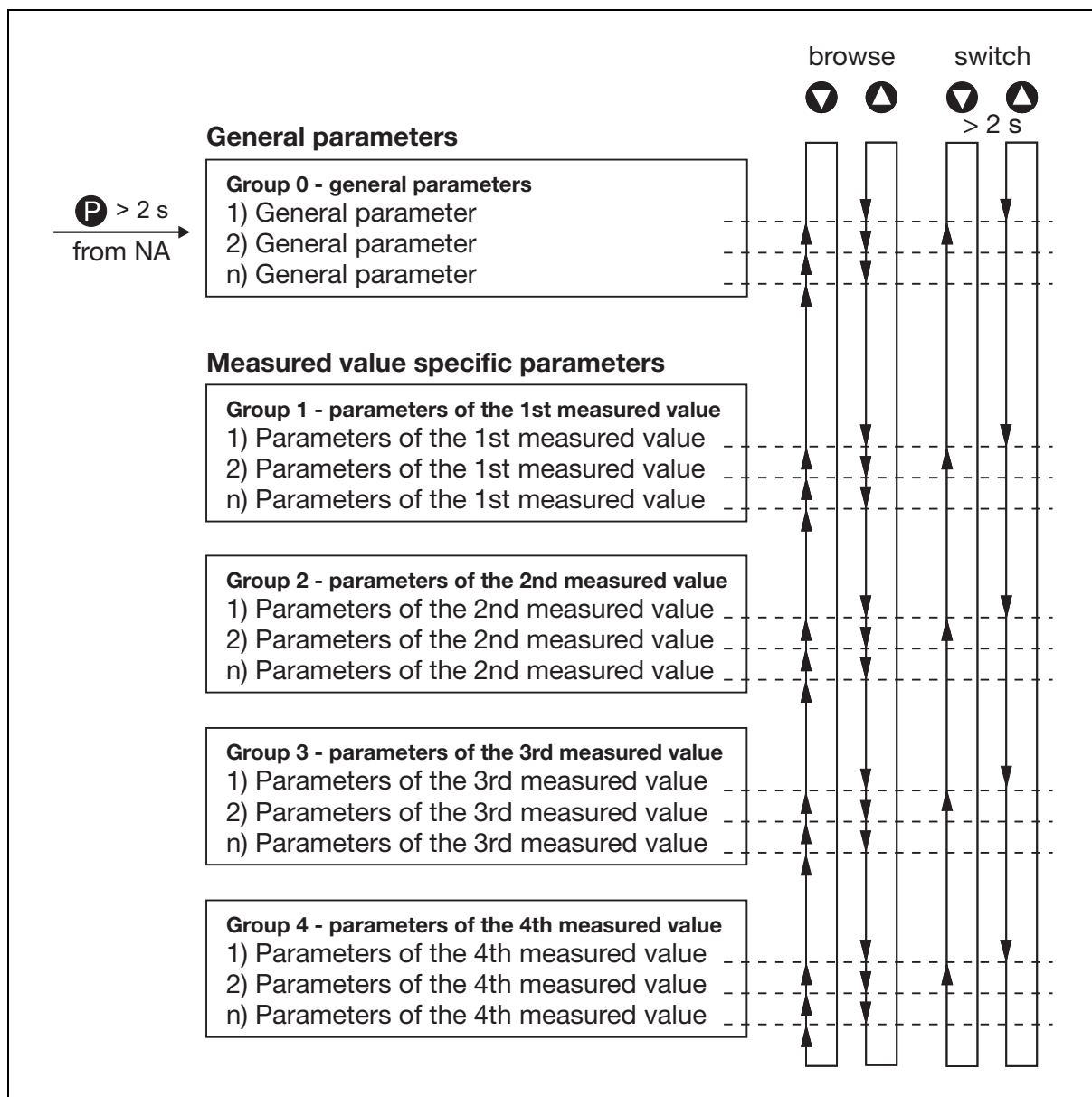

Fig. 9-2 Browsing in steps and jumping in groups

The parameter level comprises an extensive list of editable parameters that are grouped in a user-friendly manner. The key functions shown permit quick browsing up and down or jumping from one group to another.

If you are in group 1, 2, 3, or 4, the measured value no. is always displayed. Also, the configured measurand is shown within the group. No measurand is displayed for "no measured value". All measurands are displayed for the "default measured value of the automatically recognized sensor type" (plug and play).

## 9 Configuring the transmitter

### 9.2.1 Editing parameters

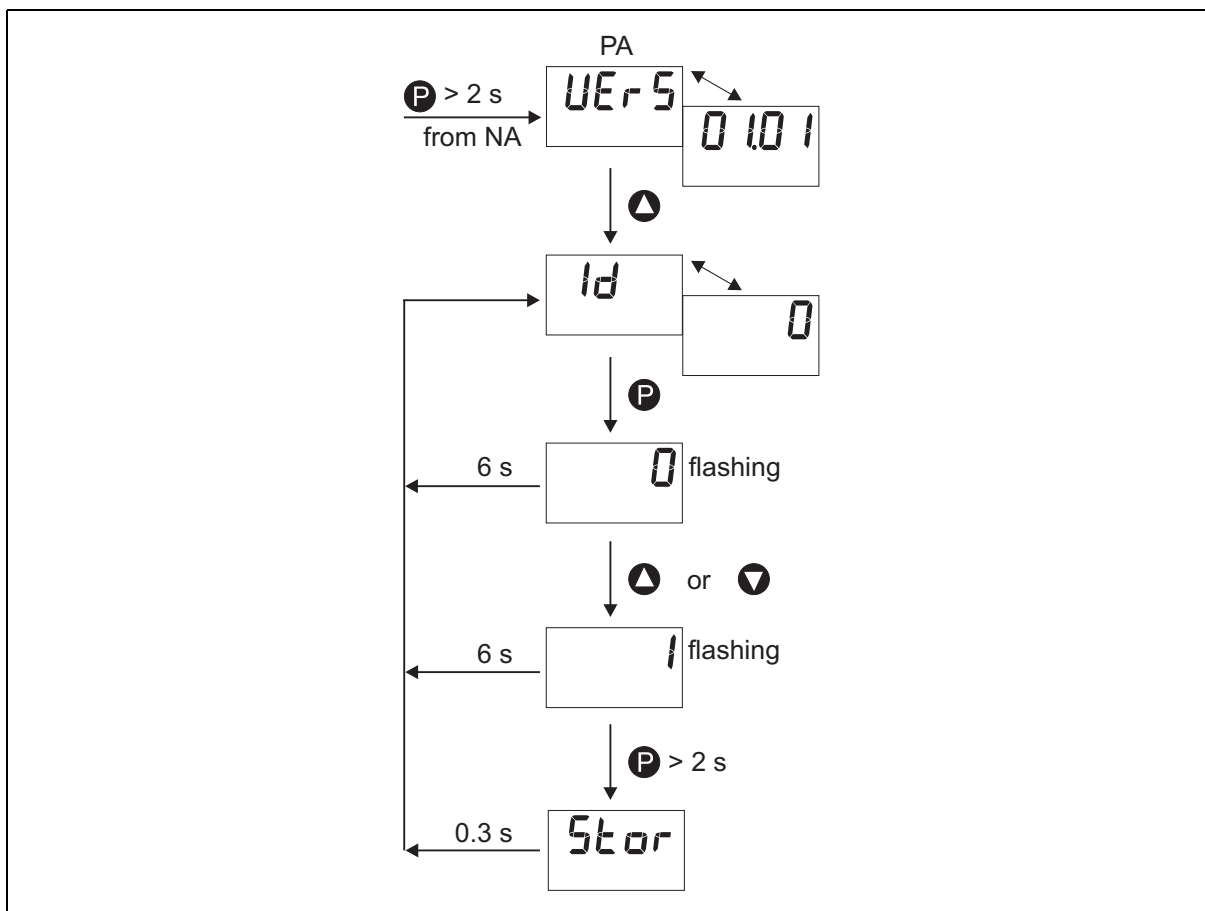

Fig. 9-3 Sample appearance for editing parameters

## 9 Configuring the transmitter

### 9.2.2 General parameters



#### NOTE!

Default settings are shown in **bold**.

Recommended procedure:

1. Enter the desired settings/values in the right-hand column of the following tables.
2. Individually select and edit the parameters one after the other.  
*This is the only way to ensure parameter entry within the default key timeout of 40 s, after the elapse of which the measuring probe automatically returns to the normal display.*  
*The selections/settings carried out so far remain unchanged.*

#### Device data

Parameter	Display	Value range/selection	
Software version	UErS	0 to 99.99 <b>Display only, cannot be edited</b>	
Customer ID	Id	<b>0</b> to 9999	
Transmission interval	Int	<b>1 (15)</b> to 3600 s	
Radio frequency	FrEq	<b>868.4 MHz</b> <b>Display only, cannot be edited</b>	
Switch on LCD display Switch off LCD display	diSP	<b>on</b> oFF	
LCD display Backlight Switch on Backlight Switch off	LigH	 on  <b>oFF</b>	
Cyclical measured value display Switch on Cyclical measured value display Switch off	AUto	<b>on</b>  oFF	
Temperature unit (Display on the transmitter)	Unit	<b>°C (degrees Celsius)</b> °F (degrees Fahrenheit)	
Code for parameter level	CodE	<b>0</b> to 9999 No code request at 0	
Battery type Lithium Alkaline	bAt	<b>LI</b> AL	

### 9.2.3 Measured value-specific parameters



#### NOTE!

Default settings are shown in **bold**.

Recommended procedure:

1. Enter the desired settings/values in the right-hand column of the following tables.
2. Individually select and edit the parameters one after the other.  
*This is the only way to ensure parameter entry within the default key timeout of 40 s, after the elapse of which the measuring probe automatically returns to the normal display.*  
*The selections/settings carried out so far remain unchanged.*

## 9 Configuring the transmitter

### Measured values 1 to 4

The following table shows the parameters to be selected for measured value 1. The same setting options can also be used for the measured values 2 to 4.

Parameter	Display	Value range/selection	
<p>Selecting the measurand</p> <p>If activation for the measurands (value range/selection 6 to 12) is not available, then these are not available for selection and are also not displayed.</p>	dAtA	<p>0 = No measured value</p> <p>1 = Measured value for automatically recognized sensor type (Plug and Play)</p> <p>2 = Pt1000 temperature [°C]</p> <p>3 = CO<sub>2</sub> [ppm CO<sub>2</sub>]</p> <p>4 = Relative humidity [%RH]</p> <p>5 = Temperature [°C]</p> <p>6 = Absolute humidity [g/m<sup>3</sup>]</p> <p>7 = Dew point temperature [°C]</p> <p>8 = Mixing ratio [g/kg]</p> <p>9 = Steam pressure [mbar]</p> <p>10 = Steam pressure [hPa]</p> <p>11 = Wet-bulb temperature [°C]</p> <p>12 = Enthalphy [kJ/kg]</p>	
<p>Measuring interval factor (Measuring interval = Transmission interval × Measuring interval factor)</p> <p>This is not displayed if the measurand has been configured to "no measured value".</p> <p><b>Restrictions:</b> Sensor for temperature (Pt1000) Min. measuring interval 1 s Default measuring interval 15 s Sensor for humidity Min. measuring interval 5 s Default measuring interval 90 s Sensor for CO<sub>2</sub> Min. measuring interval 30 s Default measuring interval 1200 s</p> <p>If Plug and Play is active, this parameter has no function.</p>	FAct	1 to 30 to 3600	
<p>Selection of the sensor channel</p> <p>This is not displayed if the measurand has been configured to "no measured value".</p>	SEnS	1 to 2	
<p>Offset (Process value correction)</p> <p>This is not displayed if the measurand has been configured to "no measured value".</p>	oFFS	-99.9 to 0.0 to +99.9	
<p>Display measured value Do not display measured value</p> <p>This is not displayed if the measurand has been configured to "no measured value".</p>	SHo	on oFF	

## 9 Configuring the transmitter

---



**NOTE!**

While editing the "Measurand selection (dAtA)" parameter with the operating keys, the measurand changes automatically.

---



**NOTE!**

The default setting for the "Measurand selection (dAtA)" parameter has the following benefits: Connect and go, no need to install device drivers or adjust further settings, the setting detects changes to the configuration if sensors or RTD temperature probes are added or removed.

---



**NOTE!**

The measuring interval factor is automatically increased in whole numbers by the measuring probe in case of lower settings until a valid measuring interval is reached.

---

## 10.1 Setup program

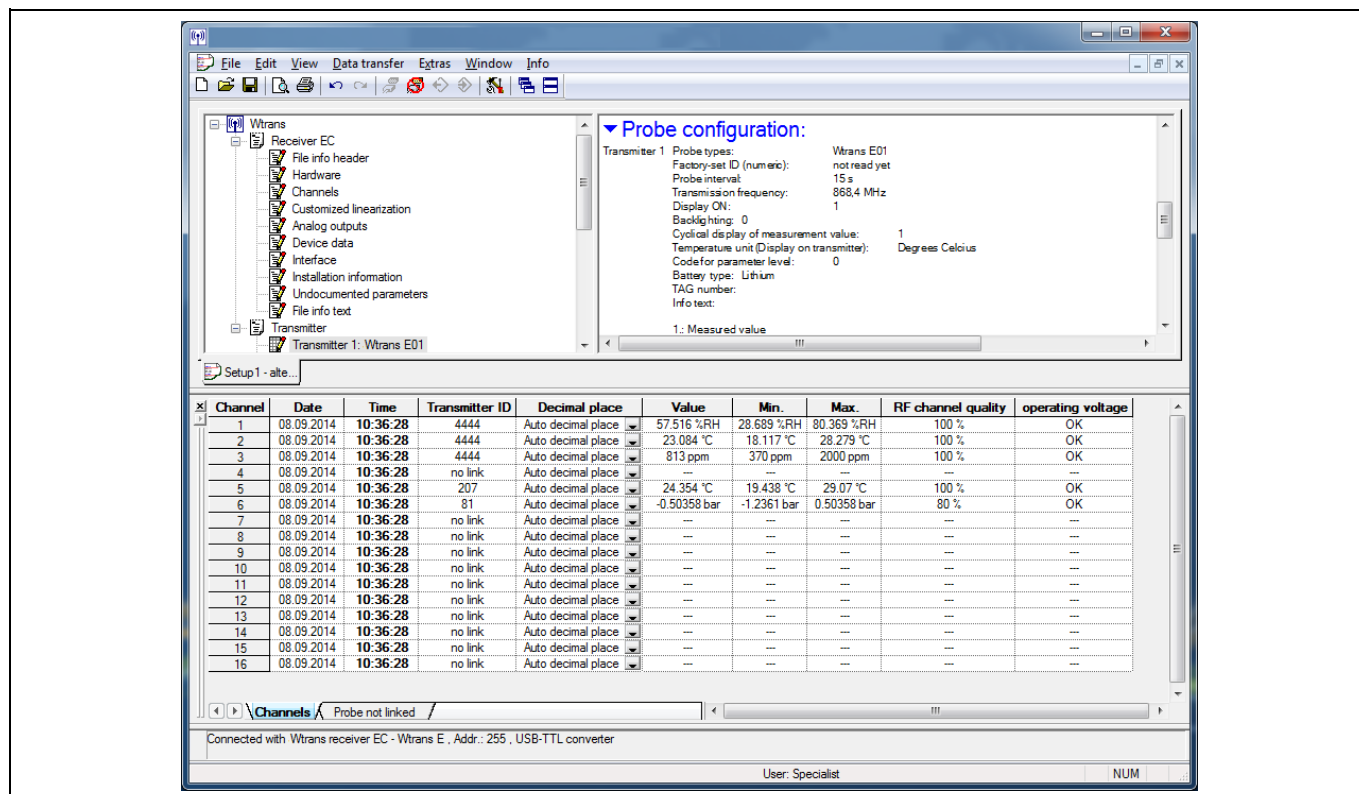

The setup program enables the measuring probe to be configured using a laptop/PC. The configuration data can be archived and printed.

Configurable parameters	Default settings
Transmitter detection (transmitter ID)	Transmitter detection (transmitter ID), consecutive
Transmission interval	All measured values are always transmitted together with a default transmission interval of 15 s. Each sensor type has its own measuring interval. <ul style="list-style-type: none"> <li>Sensor for humidity and temperature: 5 to 3600 s (per default 90 s)</li> <li>Sensor for CO<sub>2</sub>: 30 to 3600 s (per default 1200 s)</li> <li>RTD temperature probe Pt1000: 1 to 3600 s (per default 15 s)</li> </ul>
1st and 2nd measured value	Automatic sensor detection
3rd and 4th measured value	Without measured value

The setup program can be used to overwrite changed parameters with the default settings at any time. The connection between measuring probe and laptop/PC is established via a USB interface (Mini-B).

The setup program also enables other parameters to be configured, such as LCD display (switch-off, automatic measured value forwarding, backlight permanently on). Each of the four measured values can be configured (sensor selection, measurand selection, offset, measuring interval, measured value permanently on, etc.)

# 10 Setup program

---

## 10.1.1 Interface

Connection for	Type	Terminal assignment
USB connection to laptop/PC	USB interface (Mini-B)	Standard (5-pin) 

The USB interface is designed only to configure the measuring probe. Continuous operation is not admissible.

## 10.2 Hardware and software requirements

The hardware and software requirements can be obtained from the manufacturer's website.



### NOTE!

If a connection to the measuring probe or receiver cannot be established using the setup program, you may need to update the setup program.

The latest version of the setup program can be downloaded from the manufacturer's website.

---

## 10.3 Establishing the connection between the laptop/PC and measuring probe

The connection between the measuring probe and laptop/PC is established using a USB cable, type A USB connector to a Mini-B USB connector.



### CAUTION!

#### Permanent interface operation!

The USB interface is designed only to configure the measuring probe. Continuous operation is not admissible.

u Please ensure that the interface connection is disconnected after the setup data transfer.

---



### NOTE!

The setup data can also be transferred between the measuring probe and the laptop/PC without the battery or external voltage supply! The measuring probe is well supplied via the USB interface.

---

## USB connection between the laptop/PC and measuring probe

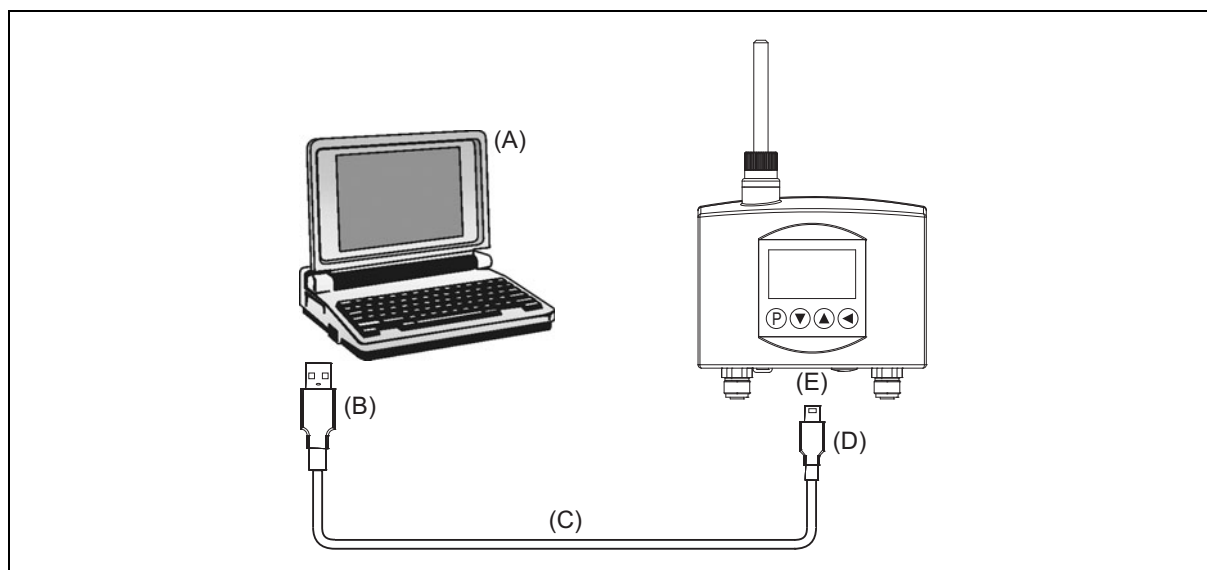

- |                          |                          |
|--------------------------|--------------------------|
| (A) Laptop/PC            | (D) Mini-B USB connector |
| (B) Type A USB connector | (E) Mini-B USB socket    |
| (C) USB cable            |                          |

For setup via USB cable, establish the following connections:

1. Insert the type A USB connector (B) of the USB cable (C) into the laptop/PC (A).
2. Insert the Mini-B USB connector (D) of the USB cable (C) into the Mini-B USB socket (E) of the measuring probe.
3. Remove the Mini-B USB connector (D) after the setup data transfer.
4. Seal the opening on the device using the supplied sealing screw M12 × 1.5 (accessories set) with the help of the mounting key (accessories set).



### NOTE!

If a USB connector is inserted, all measurements are carried out except the CO<sub>2</sub> measurement. The CO<sub>2</sub> measured values are "frozen" in the inserted USB connector. If no measured value is available, "- - - -" is displayed on the LCD display alongside the measured value number and measurand.



### NOTE!

It is **not** possible to take a CO<sub>2</sub> measurement while a USB connector is inserted.

# 10 Setup program

---

## 10.4 Configuring the transmitter

This chapter explains how to configure a transmitter using the setup program. To do this, the transmitter and the laptop/PC must be connected via a USB cable.

### 10.4.1 Establishing the communication

There are two different ways to establish the communication between the transmitter and setup program:

- Establishing the communication using the "Assistant for device settings".  
This is the case when the setup program is used for the first time (Device list empty).
- Establishing the communication without using the "Assistant for device settings".  
This is the case when the receiver/transmitter and setup program have already communicated with one another (device list with entries).

#### Establishing the communication using the "Assistant for device settings"

1. Start the setup program.
2. Select the "Establish connection" function in the "Data transfer" menu.  
*The "Assistant for device settings" appears.*
3. Select the transmitter under the "Device version" and confirm by pressing "Next".
4. Exit the assistant by clicking "Finish".  
*The device list with the selected transmitter appears.*
5. Click the "Connect" button.  
*The device list is closed, the assistant is exited, and communication between the transmitter and set-up program is established.*

#### Establishing the communication without the "Assistant for device settings"

1. Start the setup program.
2. Select the "Establish connection" function in the "Data transfer" menu.  
*The device list containing all devices entered is displayed.*
3. Left-click the desired transmitter data record to select it.
4. Click the "Connect" button.  
*The device list is closed, the assistant is exited, and communication between the transmitter and set-up program is established.*

### 10.4.2 Extracting the current transmitter parameters

1. In the "File" menu, select the "New" function.  
*The "Device assistant" starts.*
2. Confirm "**User-defined setting**" by clicking the "Next" button.
3. Select "Frequency band" and confirm with "Next".
4. Select the receiver variant and confirm by clicking "Next".
5. Exit the overview of the selected settings by clicking "Finish".  
*The current settings are displayed in the setup program.*
6. Select the desired transmitter data record from the navigation tree by left-clicking it.
7. In the "Data transfer" menu, select the "Data transfer from device" function.
8. Exit the "Save file" prompt by clicking "Skip".

The current transmitter parameters are imported to the setup program.

## 10.4.3 Editing the transmitter parameters

1. In the navigation tree, select the transmitter data record to be edited by left-clicking it twice.  
*The "Transmitter configuration" is opened.*
2. Edit the desired parameters.
3. Exit the editing procedure with "OK".
4. Save the parameters in the "File" menu with the "Save" function.

## 10.4.4 Transferring new parameters to the transmitter

1. Select the desired transmitter data record (1 to 16) from the left of the navigation tree.
2. In the "Data transfer" menu, select the "Data transfer to device" function.  
*The current parameters are transmitted to the transmitter.*
3. End the communication between the setup program and transmitter in the "Data transfer" menu using the "Disconnect connection" function.



### NOTE!

At a transmission interval of > 30 s, the transmitter transmits a link telegram (not after a change in the setup program, but after the device is started), i.e. the telegrams are transmitted at an interval of 30 s for a period of 30 minutes, and only then at the set transmission interval.

---



### NOTE!

If the setup plug is connected, the probe automatically transmits telegrams with a transmission interval of 1 s to enable the receiver to detect changes immediately. After the setup connector is removed, the telegrams are transmitted again at the set transmission interval.

---



### NOTE!

If the device is in the startup level, then it proceeds as if the USB connector had been inserted (transmission interval 1 s).

---



### NOTE!

If the configuration has been closed at the USB interface, seal the opening on the device using the supplied sealing screw M12 × 1.5 (accessories set) with the help of the mounting key (accessories set).

---

## 10 Setup program

---

## 11.1 JUMO Wtrans E01

### 11.1.1 Sensor inputs 1 and 2

Measurand/Description	Measuring range	Measuring accuracy
Humidity and temperature	see Technical data – Sensors	No impact on sensor accuracy
CO <sub>2</sub>	see Technical data – Sensors	No impact on sensor accuracy
RTD temperature probe Pt1000 in four-wire circuit (IEC 60751)	-200 to +600 °C	≤ ±0.2 K
Sensor current	≤ 500 µA	
Lead wire resistance	Maximum 11 ohm per wire	
Measuring interval		
Sensor for humidity and temperature	5 to 3600 s (per default 90 s)	
Sensor for CO <sub>2</sub>	30 to 3600 s (per default 1200 s)	
RTD temperature probe Pt1000	1 to 3600 s (per default 15 s)	

#### Measuring circuit monitoring

Behavior upon probe break or short circuit	
Sensor for humidity and temperature	Is recognized as an error and indicated with an error message (Err) on the LCD display
Sensor for CO <sub>2</sub>	Is recognized as an error and indicated with an error message (Err) on the LCD display
RTD temperature probe Pt1000	Is recognized as an error and indicated with an error message (Err) on the LCD display (if plug and play is deactivated, over or under range is indicated)

### 11.1.2 Output (wireless transmission)

Transmitter detection (transmitter ID)	Five-digit ID, factory set, four digits can be configured according to customer specifications
Transmission interval	1 to 3600 s All measured values are always transmitted together with a default transmission interval of 15 s.
Radio frequency	868.4 MHz (Europe)
Transmission power	< +10 dBm
Open air range	300 m
Output signal	All measured values can be selected. Other measurands can be derived from the values measured. They must be activated on the device (extra code/accessories). Up to four measured values can be displayed and sent to the receiver.
Configuration	Via operating keys or USB interface in combination with the setup program available as an accessory
Configurable parameters	Transmitter detection (max. 4-digit ID), transmission interval, measurands, offset, measuring interval, and LCD display

# 11 Technical data

---

## 11.1.3 Display

Technology	Positive, transfective LCD display
Size (W × H)	52 × 30 mm
LCD display	Can be switched on and off
Backlight	Can be switched on and off

## 11.1.4 Electrical data

### Voltage supply

Lithium battery	4× 1.5 V (size AA) — — —
Operating life	One year with the default settings and one sensor connected (an additional sensor, fast measuring and transmission interval, or high or low ambient temperatures reduce the batteries' operating life).
Recommended lithium batteries	Energizer Ultimate Lithium AA-L91-FR6-1.5 V This battery is part of the initial Wtrans E01 equipment and is available as an accessory.
Recommended alkaline batteries	Duracell Ultra Power Alkaline AA-MX1500-LR6-1.5 V, not available as an accessory. The information about the operating life of the lithium batteries applies only to the batteries recommended by JUMO.
External voltage supply	DC 18 to 30 V, SELV voltage — — —
Power consumption	2.4 W
Peak current	250 mA
Requirement	The device must be equipped with an electrical circuit that meets the requirements of EN 61010-1 with regard to "Limited-energy circuits".
Reverse voltage protection	Yes

## 11.1.5 Environmental influences

Ambient temperature range	With external voltage supply: -30 to +80 °C With batteries: Energizer Ultimate Lithium -20 to +60 °C Duracell Ultra Power Alkaline 0 to 50 °C
Storage temperature range	With external voltage supply: -40 to +85 °C With batteries: Energizer Ultimate Lithium -40 to +60 °C Duracell Ultra Power Alkaline -20 to +35 °C
Temperature influence for RTD temperature probe Pt1000	≤ ±0.005 % per K deviation from the reference temperature of 22 °C (% of the measuring span of -200 to +600 °C)
Site altitude	Max. 2000 m above sea level
Resistance to climatic conditions	DIN EN 60721-3-3 Standard climate 3K8H (-30 to +70 °C, 100 % RH) Dripping water 3Z7
Vibration resistance	DIN EN 60068-2-6 Table C.2 (general industrial use) Frequency range: 10 to 55 Hz Amplitude: 0.15 mm Cycles per axis: 10
Electromagnetic compatibility (EMC) Interference emission Interference immunity Radio frequency spectrum	DIN EN 61326-1 Class B – household and small businesses – Industrial requirements ETSI EN 300 220-1 and ETSI EN 300 220-2

## 11.1.6 Case

Material	PC-ABS (polycarbonate acrylonitrile butadiene styrene), RAL 9003 signal white
Flammability class	UL94 V-0
Dimensions with lambda/4 antenna, connection for sensor and RTD temperature probe Pt1000 (W × H × D)	133.6 × 210.0 × 60.5 mm
Mounting	Wall mounting using DIN rail piece (can be used inside and outside of buildings)
Connections for sensors and RTD temperature probe Pt1000	2× plug connector M12 × 1 with internal thread and union nut
Protection type	IP65
Cleaning	The device can be cleaned with conventional washing, rinsing, and cleaning agents
Installation position	Vertical ⊥
Weight	Approx. 550 g (incl. 4 batteries)

# 11 Technical data

## 11.2 Sensors

These sensors are available as accessories. They can be connected directly to the measuring probe. Antenna and extension cables enable indirect mounting.

### Sensor for humidity and temperature

Measurand	Measuring range	Measuring accuracy
Relative humidity	0 to 100 % RH (RH = relative humidity)	±2 % RH (0 to 90 % RH) ±3 % RH (90 to 100 % RH)
Temperature	-40 to +80 °C	±0.2 K at 20 °C

More technical data for the sensor for humidity and temperature can be downloaded from the Internet.

### Sensor for CO<sub>2</sub>

Measurand	Measuring range	Measuring accuracy
CO <sub>2</sub> concentration	0 to 2000 ppm	≤ ±(50 ppm + 2 % of the measuring range)
CO <sub>2</sub> concentration	0 to 5000 ppm	≤ ±(50 ppm + 3 % of the measuring range)
CO <sub>2</sub> concentration	0 to 10000 ppm	≤ ±(100 ppm + 5 % of the measuring range)

More technical data for the sensor for CO<sub>2</sub> can be downloaded from the Internet.

### RTD temperature probe Pt1000

Description	Measuring range	Measuring accuracy
RTD temperature probe Pt1000, class A acc. to DIN EN 60751	-50 to +150 °C	±(0.15 K + 0.002 ×  t )  t  = measured temperature in °C without prefix
Connection type	Four-wire circuit	
Response times	Water 0.4 m/s, air 3.0 m/s	
Protection tube diameter 4.0 mm	Water t <sub>0.5</sub> approx. 3 s, t <sub>0.9</sub> approx. 7 s, air t <sub>0.5</sub> approx. 25 s, t <sub>0.9</sub> approx. 80 s	
Ambient temperature range	-50 to +150 °C	
Storage temperature range	-50 to +150 °C	
Case material	Stainless steel	
Connection	Plug connector M12 × 1 with external thread	
Protection type	IP65 with connected mating connector	
Installation position	Any	
Weight	Approx. 10 g	

Other connectable RTD temperature probes Pt1000 can be found in the Accessories section and the data sheets 902150 and 902815.

 有毒有害物质或元素 Hazardous substances		铅 (Pb)	汞 (Hg)	镉 (Cd)	六价铬 (Cr(VI))	多溴联苯 (PBB)	多溴二苯醚 (PBDE)
		部件名称 Product group: 902928	X	○	○	○	○
外壳 Housing (Gehäuse)	○	○	○	○	○	○	○
过程连接 Process connection (Prozessanschluss)	○	○	○	○	○	○	○
-螺母 Nut (Mutter)	○	○	○	○	○	○	○
螺钉 Screw (Schraube)	○	○	○	○	○	○	○

本表格依据 SJ/T 11364-2014 的规定编制。  
 (This table is prepared in accordance with the provisions of SJ/T 11364-2014.)  
 O : 表示该有害物质在该部件所有均质材料中的含量均在 GB/T 26572 规定的限量要求以下。  
 (O: Indicates that said hazardous substance contained in all of the homogeneous materials for this part is below the limit requirement of GB/T 26572.)  
 X : 表示该有害物质至少在该部件的某一均质材料中的含量超出 GB/T 26572 规定的限量要求。  
 (X: Indicates that said hazardous substance contained in one of the homogeneous materials used for this part is above the limit requirement of GB/T 26572.)

## 12 China RoHS

---





**JUMO GmbH & Co. KG**

Street address:  
Moritz-Juchheim-Straße 1  
36039 Fulda, Germany

Delivery address:  
Mackenrodtstraße 14  
36039 Fulda, Germany

Postal address:  
36035 Fulda, Germany

Phone: +49 661 6003-0  
Fax: +49 661 6003-607  
Email: [mail@jumo.net](mailto:mail@jumo.net)  
Internet: [www.jumo.net](http://www.jumo.net)

**JUMO Instrument Co. Ltd.**

JUMO House  
Temple Bank, Riverway  
Harlow, Essex, CM20 2DY, UK

Phone: +44 1279 63 55 33  
Fax: +44 1279 62 50 29  
Email: [sales@jumo.co.uk](mailto:sales@jumo.co.uk)  
Internet: [www.jumo.co.uk](http://www.jumo.co.uk)

**JUMO Process Control, Inc.**

6724 Joy Road  
East Syracuse, NY 13057, USA

Phone: +1 315 437 5866  
Fax: +1 315 437 5860  
Email: [info.us@jumo.net](mailto:info.us@jumo.net)  
Internet: [www.jumousa.com](http://www.jumousa.com)

