

# JUMO dTRANS T06

Multifunctional Four-Wire-Transmitter  
in Mounting Rail Case in Accordance with  
DIN EN 61508 and EN ISO 13849



**RA**<sup>®</sup>  
US



**Operating instructions**  
(translation of the German  
original manual)

70707100T90Z001K000

**JUMO**

V8.00/EN/00690362/2025-02-28

# Operating overview

Normal display (12s after switch-on or Time-out)

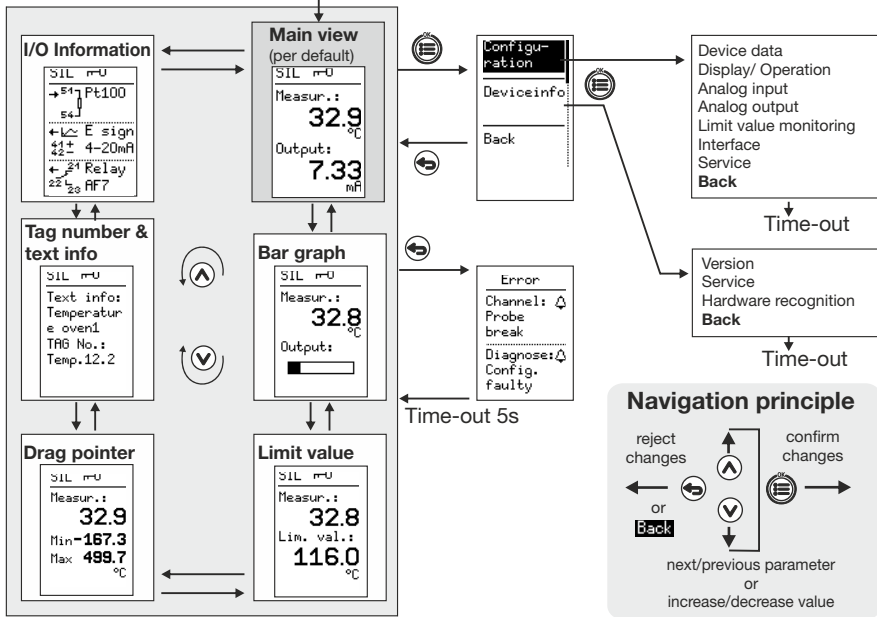

---

	<b>Operating overview</b> .....	<b>2</b>
<b>1</b>	<b>Brief description</b> .....	<b>10</b>
1.1	Safety information .....	11
<b>2</b>	<b>Identifying the device version</b> .....	<b>12</b>
2.1	Scope of delivery .....	13
2.2	Accessories .....	14
2.3	Device software version, fabrication number .....	14
2.4	Service addresses .....	15
<b>3</b>	<b>Mounting</b> .....	<b>16</b>
3.1	Dimensions .....	16
3.2	Mounting site, DIN-rail mounting .....	17
3.3	Close mounting .....	17
3.4	Dismounting .....	18
3.5	Galvanic isolation .....	19
3.6	Use of the USB interface .....	19
<b>4</b>	<b>Electrical connection</b> .....	<b>20</b>
4.1	Installation notes .....	20
4.2	Connection diagram .....	21
4.2.1	Analog input (part of the safety channel) .....	22
4.2.2	Analog output (part of the safety channel) .....	24
4.2.3	Voltage supply (on the nameplate) .....	24
4.2.4	Extra codes .....	25
<b>5</b>	<b>Startup of the device</b> .....	<b>26</b>

---

5.1	Display and control elements . . . . .	26
5.2	Setting the display after device is switched on . . . . .	26
5.3	Extra code SIL . . . . .	28
5.4	Signal flow . . . . .	29
<b>6</b>	<b>Safety Manual . . . . .</b>	<b>32</b>
6.1	Brief description, intended use . . . . .	32
6.2	Validity of the safety manual . . . . .	33
6.3	Special operating statuses. . . . .	33
6.3.1	Behavior after a power failure . . . . .	33
6.3.2	During setup data transfer. . . . .	33
6.3.3	After alteration of the configuration level (at the device or through setup) . . . . .	33
6.3.4	Issue of an error signal (safe state) . . . . .	34
6.4	Relevant standards . . . . .	34
6.5	Connection possibilities of the sensors . . . . .	34
6.5.1	Terms and abbreviations according to DIN EN 61508 and DIN EN 61511. . . . .	35
6.5.2	Safety-relevant parameters. . . . .	38
6.5.3	Failure rates and SFF for 707071/X – 23/XXX (AC240V) . . . . .	38
6.5.4	Failure rates and SSF for 707071/X – 29/XXX (DC24V) . . . . .	38
6.5.5	Calculation of PFD avg . . . . .	39
6.6	Determining the safety integrity level (SIL) . . . . .	41
6.6.1	Safety integrity of the hardware . . . . .	42
6.6.2	Safety-relevant system properties . . . . .	43
6.6.3	Redundant use of the system . . . . .	44
6.6.4	Sensor connection possibilities. . . . .	45
6.7	Determining the achieved performance level PL . . . . .	45
6.7.1	Terms and abbreviations according to standards series DIN EN ISO 13849 . . . . .	46

---

6.7.2	Calculations of the DIN EN ISO 13849-1 performance level – 707071/X - 23/XXX (AC240V) .....	47
6.7.3	Calculations of the DIN EN ISO 13849-1 performance level – 707071/X - 29/XXX (DC24V) .....	47
6.7.4	Risk reduction through the control system .....	48
6.8	Other applicable device documentation .....	49
6.9	Behavior during operation and in case of malfunction .....	49
6.10	Regular tests .....	49
6.10.1	Proof test A .....	50
6.10.2	Proof test B .....	51
6.10.3	Proof test C .....	56
6.10.4	Recommended tests for temperature probes .....	57
<b>7</b>	<b>Configuration .....</b>	<b>60</b>
7.1	Overview .....	60
7.2	Device data .....	61
7.2.1	Language .....	61
7.2.2	Unit .....	61
7.2.3	Language after power on .....	61
7.3	Display/operation .....	62
7.3.1	Normal display .....	62
7.3.2	Decimal place .....	62
7.3.3	Contrast .....	62
7.3.4	Lighting .....	63
7.3.5	Time-out lighting .....	63
7.3.6	Time-out operation .....	63
7.3.7	Code .....	63
7.4	Analog input .....	64
7.4.1	Sensor type .....	64
7.4.2	Linearization .....	65

- 7.4.3 Temperature difference . . . . .66
- 7.4.4 Temperature compens. . . . .66
- 7.4.5 Resistance measuring range . . . . .66
- 7.4.6 Line resistance . . . . .66
- 7.4.7 Sensor factor . . . . .66
- 7.4.8 Resistance Rx . . . . .67
- 7.4.9 Line resistance RL . . . . .67
- 7.4.10 Resistance R0 . . . . .67
- 7.4.11 Resistance RA, RS and RE . . . . .68
- 7.4.12 Scaling start . . . . .68
- 7.4.13 Scaling end . . . . .68
- 7.4.14 Offset . . . . .68
- 7.4.15 Fine calibration start actual . . . . .68
- 7.4.16 Fine calibration end actual . . . . .68
- 7.4.17 Fine calibration start target . . . . .68
- 7.4.18 Fine calibration end target. . . . .68
- 7.4.19 Noise suppression. . . . .68
- 7.5 Analog output. . . . .69
  - 7.5.1 Signal type. . . . .69
  - 7.5.2 Output range start . . . . .69
  - 7.5.3 Output range end . . . . .69
  - 7.4.20 Filter time constant . . . . .69
  - 7.5.4 Scaling start . . . . .70
  - 7.5.5 Scaling end . . . . .70
  - 7.5.6 Reversion output . . . . .70
  - 7.5.7 Error signal . . . . .70
  - 7.5.8 Response for limit error. . . . .70

---

- 7.5.9 Signal from diagnosis error .....70
- 7.5.10 Simulation output .....71
- 7.5.11 Simulation value .....71
- 7.5.12 Behavior when leaving the scaling range .....72
- 7.6 Limit value monitoring .....73
  - 7.6.1 Function.....73
- 7.7 RS485 interface .....74
  - 7.7.1 Baud rate.....74
  - 7.6.2 Limit value .....74
  - 7.6.3 Switch difference.....74
  - 7.6.4 Switching behavior .....74
  - 7.6.5 Switch on delay.....74
  - 7.6.6 Switch off delay.....74
- 7.8 Service .....75
  - 7.8.1 Minimum meas. value .....75
  - 7.8.2 Maximum meas. value.....75
  - 7.8.3 Min.value reset .....75
  - 7.8.4 Max.value reset.....75
  - 7.8.5 Switching cycle limit .....75
  - 7.7.2 Data format .....75
  - 7.7.3 Device address .....75
  - 7.8.6 Current switching cycles.....76
- 8 Device info .....77**
  - 8.1 Version .....77
  - 8.2 Service .....78
    - 8.2.1 Operating hours total.....78

---

8.2.2	Operating hours since last configuration	.78
8.3	Hardware recognition	.78
<b>9</b>	<b>Technical data</b>	<b>80</b>
9.1	Analog input	.80
9.1.1	RTD temperature probe	.80
9.1.2	Thermocouples	.82
9.1.3	Standard signals	.83
9.1.4	Resistance transmitter	.84
9.1.5	Resistance/potentiometer	.85
9.2	Measuring circuit monitoring	.85
9.3	Test voltages	.86
9.4	Electrical safety	.86
9.5	Analog output	.86
9.6	Relay output (extra code 018)	.87
9.7	Display	.87
9.8	Electrical data	.88
9.9	Environmental influences	.88
9.10	Housing	.88
9.11	Approvals/approval marks	.89
<b>10</b>	<b>Setup program</b>	<b>90</b>
10.1	Minimum hardware and software requirements	.90
10.2	Displaying the device software version	.90
10.3	Forgotten the code?	.91
10.4	Customer-specific linearization	.91
10.5	Reset drag indicator	.92

---

10.6 Switch on / switch off SIL extra code .....93

10.7 Checking of safety relevant system settings .....93

**11 Error messages ..... 94**

11.1 Display types .....94

11.2 Safety channel .....95

11.3 Diagnostics channel .....97

11.4 Measured value recording .....99

**12 What to do, if ... ..... 100**

**13 Certificates ..... 104**

13.1 EU-Conformity .....105

13.2 SIL and PL .....109

13.3 DNV .....110

13.4 China RoHS .....113

---

## **1 Brief description**

The transmitter acquires the temperature through an RTD temperature probe or a thermocouple (double thermocouple). The transmitter can also acquire standard signals such as .current 0(4) to 20 mA or voltage 0 to (1)10 V.

Additionally resistance transmitter with three-wire circuit, or resistance/potentiometer with two-wire/three-wire/four-wire circuit can be acquired.

The output signal is galvanically isolated from the measurement input and the voltage supply.

Depending on the measurement input, different linearization variants (linear, temperature-linear, customer-specific, etc.) are possible. Output signal: variants 0(4) to 20 mA and, alternatively, 0(2) to 10 V are available.

Process variables such as temperature or pressure are reliably emitted at the analog output and monitored for measuring over-range and underrange.

Type 707071 is functionally expandable through the extra code, relay output and an RS485 interface.

Visualization of measured values is accomplished using a dot-matrix LCD display with white backlight.

On the LCD display, it is possible to call up the connection diagram of the configured sensor input, signal output, as well as the optional relay and interface assignment.

If a malfunction occurs the transmitter sends a defined output signal when the analog output is configured to 4 to 20 mA according to the recommendation of NAMUR NE 43, which can be recognized by downstream systems.

The operating status is signaled optically using a two-color LED (red/green).

Smooth operation is indicated by a permanent green LED; malfunction statuses are indicated by a permanent red LED.

The sensor type, measuring range, linearization, output signal, limit values, etc. can be configured via setup program.

Alternatively, configuration is also possible via four keys on the device.





Type 707071/8-XX-058 fulfills the requirements of SIL 2, or SIL 3 in redundant use, according to DIN EN 61508 and PL c/PL d according to DIN EN ISO 13849 as well as the requirements of DIN EN 60730-2-9.

The systematic suitability is defined at SC = 3 for HW and SW.

This means that SIL 2 or PL c for HFT = 0 (individual device) and SIL 3 or PL d for HFT = 1 (2 devices) is achieved.

The use of type 707071/8-XX-058 enables early and reliable detection of risks which could potentially result in personal injuries, environmental damage, or destruction of the production plant and production materials.

## 1.1 Safety information

Symbol	Meaning	Explanation
	Important information	This symbol refers to important information about the product, its handling, or additional benefits.
	Danger	This symbol indicates that personal injury from electrocution may occur if the appropriate precautionary measures are not taken.
	Caution	This symbol in connection with the signal word indicates that <b>material damage</b> or <b>data loss</b> will occur if the respective precautionary measures are not taken.
	Warning	This symbol in connection with the signal word indicates that <b>personal injury</b> may occur if the respective precautionary measures are not carried out.
	Read	This symbol, which is attached to the device, indicates that the device-specific documentation must be followed. This is necessary in order to recognize the nature of the potential danger and take the necessary measures to prevent it. Manipulations not described in the operating manual or expressly forbidden will jeopardize your warranty rights.
⇒	Reference	This symbol refers to further information in other manuals, chapters, or sections.
abc <sup>1</sup>	Footnote	Remarks at the end of a page that <b>refer to</b> specific text passages and are marked with a number placed in superscript.
★	Action instruction	The steps (marked with an asterisk) must be carried out one after another in the reading order.

## 2 Identifying the device version

The nameplate is glued laterally to the device.

**JUMO GmbH & Co. KG** 36039 Fulda  
Germany  
www.jumo.net



Typ: 707071/8-23/000  
SW: 348.01.01/349.01.01  
⊖ 0...100 °C Pt100 dl  
⊕ 4...20 mA  
~ AC 110...240 V +10/-15 %, 48...63 Hz, max. 3 W, 10 VA

**UL US CE**

F-Nr: 0000000001001010000 TN: 00694860

Voltage supply AC 110 to 240 V:

**JUMO GmbH & Co. KG** 36039 Fulda  
Germany  
www.jumo.net



Typ: 707071/8-29/018,058,  
SW: 348.01.01/349.01.01  
⊖ 0...100 °C Pt100 dl  
⊕ 4...20 mA  
= DC 24V +10/-15 %, max. 3 W

**UL US CE**

F-Nr: 0000000001001010000 TN: 00700595

SIL approval



Voltage supply DC 24 V:

(The device has only to be connected at SELV- or PELV-circuits)



### Caution

The voltage supply that is connected must correspond to the voltage specified on the nameplate!

<b>(1)</b>	<b>Basic type</b>
707071	dTRANS T06
<b>(2)</b>	<b>Version</b>
8	Standard with default settings
9	Customer-specific configuration (specifications in plain text)
<b>(3)</b>	<b>Voltage supply</b>
23	AC 110 to 240 V +10/-15 %, 48 to 63 Hz
29	DC 24 V +10/-15 % (The device has only to be connected at SELV- or PELV-circuits)
<b>(4)</b>	<b>Extra codes <sup>a</sup></b>
000	None
018	RS485 interface Modbus RTU and relay output
058	SIL and PL approval (yellow front foil)
062	DNV approval

**(1)** / **(2)** - **(3)** / **(4)**

**Order code**

/  -  /  , <sup>a</sup>

**Order example**

707071 / 8 - 23 / 000 , 000

<sup>a</sup> List extra codes in sequence, separated by commas

## 2.1 Scope of delivery

- Type 707071 in the ordered version
  - Operating manual
- ⇒ The interface description is available as a download.

## 2.2 Accessories

Item	Part no.
Setup program on CD-ROM, multilingual	00668006
USB cable A-connector to Micro-B connector, length 3 m, for type 707071	00616250
Screw-on end clamp for mounting rail	00528648

## 2.3 Device software version, fabrication number

⇒ Chapter 8.1 "Version"



### Read

This operating manual is the translation of the **German manual**.  
It is valid for the following hardware and software version(s):

Hardware-Version(en)	Software-Version(en)
0	Channel: 348.01.01, 348.02.01, 348.02.02 Diagnosis: 349.01.01, 349.02.01, 349.02.02, 349.02.03
1	Channel: 348.03.02 Diagnosis: 349.03.03



### Important information

Keep the operating manual in a place that is accessible to all users at all times.  
Use the device software version to check that the documentation matches your device.



### **Caution**

All the necessary settings are described in the operating manual.

Manipulations that are not described in the operating manual or that are expressly forbidden will jeopardize your warranty rights and may render the assured function inoperative!

Any interference with the inside of the device is prohibited!

Repairs may be only performed by JUMO in the company's headquarters in Fulda.

If you have any problems, please contact the nearest branch office or the head office.

## **2.4 Service addresses**

⇒ See back cover

## 3 Mounting

### 3.1 Dimensions

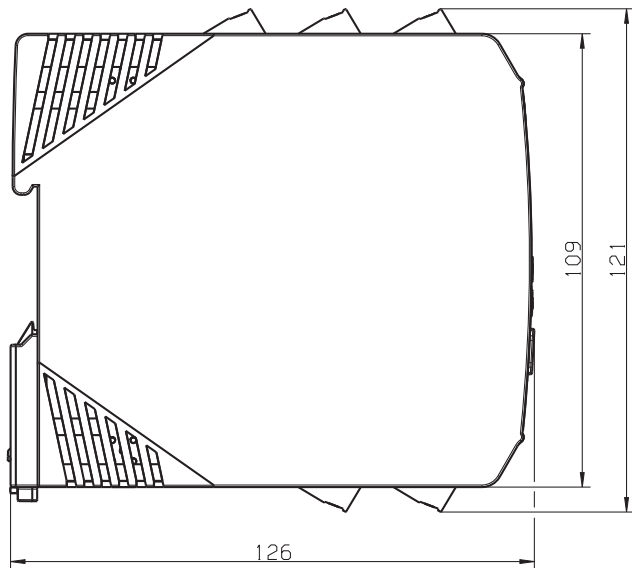
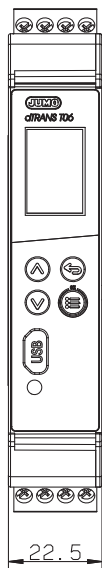

## 3.2 Mounting site, DIN-rail mounting



### Warning

The device is **not** suitable for installation in potentially explosive areas.  
The device is clipped to a 35 mm DIN-rail (DIN EN 60715) from the front and locked into place by pressing downwards.

- The ambient conditions at the installation site must meet the requirements specified in the technical data.  
⇒ Chapter 9 "Technical data"

- Ensure vibration-free installation to prevent the screw connections from working loose!
- The atmosphere must be free from aggressive media (e.g. acids and lyes), as well as free from dust, flour, or other suspended solids to prevent blocking of the cooling slots!



## 3.3 Close mounting

- Maintain the minimum distance of 20 mm to the top and the bottom.
  1. So that the release slot can still be accessed with a screwdriver from the bottom.
  2. So that when dismantling, the device can be swiveled upwards and removed from the DIN rail.
- Several devices can be mounted right next to one another without a minimum distance.

### 3.4 Dismounting

- Place screwdriver in release slot and press upwards (1).
- Remove housing upwards (2).

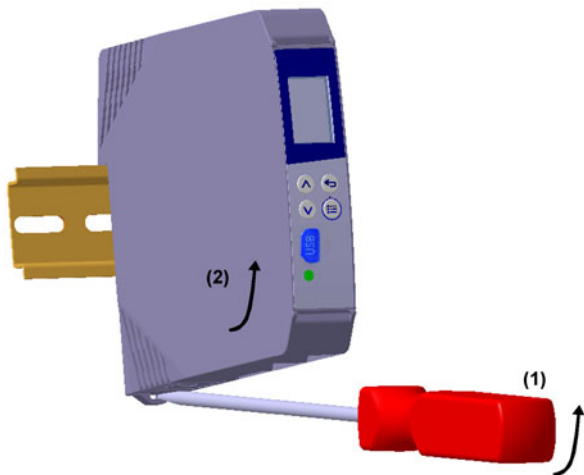

## 3.5 Galvanic isolation

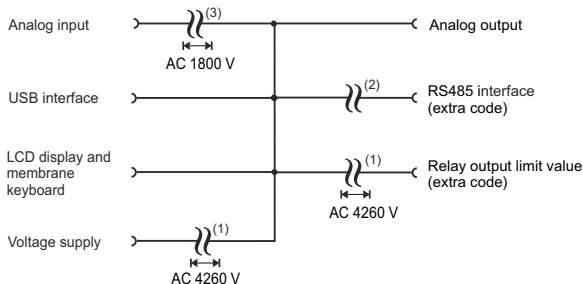

(1) The voltage specifications correspond to the alternating test voltages (effective values) according to EN 61010-1 for type testing.

(2) Functional galvanic isolation for the connection of SELV or PELV circuits.

(3) The voltage specification corresponds to the alternating test voltage (effective value) according to DIN EN 61010-1 for type testing to connect SELV or PELV electrical circuits [secondary electrical circuits which are derived from supply current circuits with overvoltage category III (>150 V ≤ 300 V)].

## 3.6 Use of the USB interface

- The USB interface is only designed for service use over a limited period, since the device switches the output signal to safe state when in SIL operation during data transmission with the setup program!
- The RS485 interface is suitable for unlimited operation of the interface in a fixed installation.

## 4 Electrical connection

### 4.1 Installation notes

- Check to see if the device is installed in a manner appropriate to the application (temperature measurement) and that it is operated within the admissible plant parameters.
- The device is intended to be installed in switch cabinets, machines, or plants. Ensure that the customer's fuse protection does not exceed 20 A.
- Disconnect the device from the mains voltage on all poles prior to starting service or repair work.
- All incoming and outgoing lines without a connection to the power supply network must be laid with shielded and twisted lines. Connect the screen on the device to ground.
- Do not lay the input and output cables close to components or lines through which current is flowing.
- Do not connect any additional loads to the screw terminals for the voltage supply of the device.
- Both the choice of cable material for the installation as well as the electrical connection of the device must conform to the local requirements of VDE 0100 "Regulations on the Installation of Power Circuits with Nominal Voltages below 1000 V" or the appropriate regulations for the country.
- Suitable measures must be taken to protect the relay circuit. The maximum switching capacity is 240 V, 3 A (resistive load).
- The electromagnetic compatibility conforms to the standards and regulations cited in the technical data.  
⇒ Chapter 9 "Technische Daten"
- As part of the startup, it is recommended to carry out a test run of the system until the measuring range is exceeded (output of a diagnostic error) so that the output signal switches to safe state.
- Under operating conditions the temperature on the screw terminals can exceed 60° C. This can destroy the cable isolation of the connection wires. The cabling must be temperature resistant up to 80 °C.

#### Caution



The electrical connection and settings in the configuration level up to system startup may only be carried out by qualified personnel.

## 4.2 Connection diagram

The connection is made via slot-encoded screw terminals.







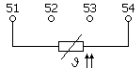
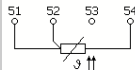
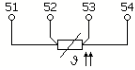
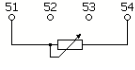
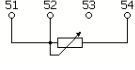
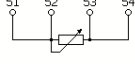

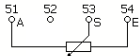
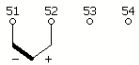
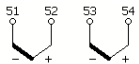
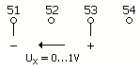
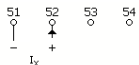
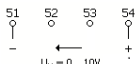

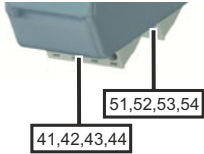
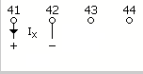
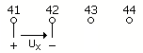
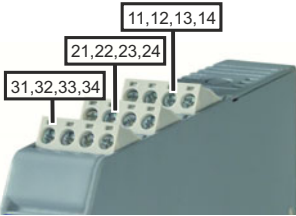

**Note:** Please ensure that any terminals removed for wiring or device exchange are reconnected at the correct position.



Conductor	Admissible cross section
Rigid or flexible	0.2 to 2.5 mm <sup>2</sup>
Flexible with ferrule with or without plastic sleeve	0.25 to 2.5 mm <sup>2</sup>
AWG	12 to 24
2 rigid / flexible conductors with equal cross section	0.2 to 1 mm <sup>2</sup>
2 flexible conductors with equal cross section, ferrule without plastic sleeve	0.25 to 1 mm <sup>2</sup>
2 flexible conductors with equal cross section, ferrule with plastic sleeve	0.5 to 1.5 mm <sup>2</sup>
AWG according to UL/CUL	12 to 30
Tightening torque of screws: max. 0.6 Nm	
<p><b>Caution</b></p>  <p>See special notes relating to the heat resistance of cables.</p>	

Terminals	Comment	Screw terminals
<b>4.2.1 Analog input (part of the safety channel)</b>		
 <p data-bbox="59 919 244 940">■ Default setting</p>	RTD temperature probe in two-wire circuit	
	RTD temperature probe in three-wire circuit	
	RTD temperature probe in four-wire circuit	
	Resistance/potentiometer in two-wire circuit	
	Resistance/potentiometer in three-wire circuit	
	Resistance/potentiometer in four-wire circuit	

Terminals	Comment	Screw terminals
	Potentiometer/WFG A: Start resistance S: Loop resistance E: End resistance	
	Thermocouple	
	Double thermocouple (galvanically isolated) The thermocouple on terminals 53 and 54 is only used for sensor breakage detection and is not displayed as a measured value.	
	mV input (0 to 1 V)	
	4 to 20 mA	
	0 to 20 mA	
0 to 10 V		

Terminals	Comment	Screw terminals												
<b>4.2.2 Analog output (part of the safety channel)</b>														
<p><b>Note:</b> An open current output is detected and leads to an error.</p> <p><b>Remedy:</b> Install a 470 <math>\Omega</math> resistor until the output in the system is wired correctly.</p>														
	0(4) to 20 mA													
	0(2) to 10 V													
<b>4.2.3 Voltage supply (on the nameplate)</b>														
<p>⇒ Chapter 2 "Identifying the device version"</p>														
	<p><b>AC:</b>                      L1 line conductor                      N Neutral conductor</p> <p><b>DC:</b>                      (L+)                      (L-)                      The device has only to be connected at SELV- or PELV-circuits</p>	<table style="margin: auto;"> <tr> <td>L1</td> <td>N</td> <td>(L+)</td> <td>(L-)</td> </tr> <tr> <td></td> <td></td> <td></td> <td></td> </tr> <tr> <td>11</td> <td>12</td> <td>13</td> <td>14</td> </tr> </table>	L1	N	(L+)	(L-)					11	12	13	14
L1	N	(L+)	(L-)											
														
11	12	13	14											

Terminals	Comment	Screw terminals
(3)	<b>USB interface</b> (Device) Micro-B connector, standard (5-pin)	

#### 4.2.4 Extra codes

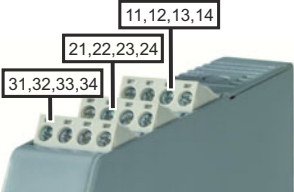
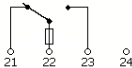
	<p><b>Relay output (zero-current state)</b> Relay (changeover contact) with installed micro fuse 3.15 A, slow is is part of the safety channel.</p>	
	<p><b>RS485 interface</b></p>	

■ Default setting

## 5 Startup of the device

### 5.1 Display and control elements

- \* When the voltage supply is set up, a self-test begins during which the back-lit display shows white pixels for 2 s and then black pixels for 2 s. The LED lights up simultaneously red and green.

The self-test



is followed by a language request



and then the main measured value appears:

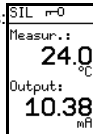

⇒ If an error message appears, see Chapter 11 "Error messages".

### 5.2 Setting the display after device is switched on

The main measured value appears on the screen in German (default setting).

Once a probe has been connected, the device displays a measured value of 24.0 °C and an output signal of 10.38 mA as an example here.



#### Important information

If something else is to be displayed after switch-on, this can be adjusted as follows:





⇒ Chapter 7.3.1 "Normal display"

Since the relay output is set to **"no function"** at the factory, the relay does not respond at all.

⇒ Chapter 7.6 "Limit value monitoring"

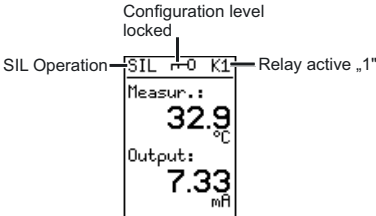
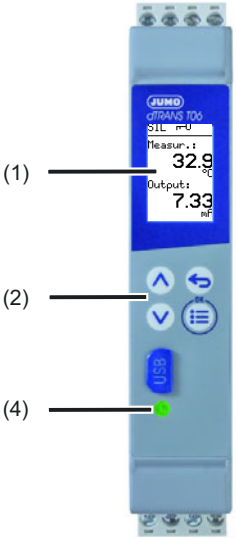
As long as the measured value is detected correctly, it switches, depending on the set limit value and switching behavior.

In the event of an error, the relay is switched off (inactive "0").

Legend	Comment	Diagram
1	<p><b>LCD display</b> Black/white with backlight, 64 x96 pixels</p> 	
2	<p><b>Keys</b></p> <ul style="list-style-type: none"> <li> Increase value / previous menu item</li> <li> Reduce value / next menu item</li> <li> Back / cancel change</li> <li> One level lower in the menu, confirm change</li> </ul>	
4	<p><b>LED</b> Lights up ● <b>green</b> if the diagnostic function does not detect any errors. Lights up ● <b>simultaneously red and green</b> upon device restart, during simulation of analog output, and during active setup data transfer. Lights up ● <b>red</b> if the diagnostic function detects errors (e.g. if the limits for the signal type are exceeded in the signal flow figure below).</p>	

### 5.3 Extra code SIL

For a device with extra code 058, SIL operation is activated per default and shown in the display at the top left.

#### The following specifications apply in SIL operation:

- 1.) Only the following sensor types can be set at the analog input:  
Double thermocouple, RTD temperature probe or 4 to 20 mA
- 2.) Only the signal type 4 to 20 mA can be set at the analog output, simulation cannot be activated and only high or low can be selected as an error signal, not any value.
- 3.) The following changes during operation:  
Double confirmation for safety relevant parameters is active.
- 4.) Diagnostics:  
No check of analog output, safe state during setup transmission, temperature range of terminal is monitored, device enters safe state when leaving the range.
- 5.) Display:  
Display of SIL in top left corner
- 6.) The membrane keyboard on a device with extra code 058 is yellow:



#### Important information

It is possible to deactivate SIL in the setup program:

⇒ Chapter 10.6 "Switch on / switch off SIL extra code"

## 5.4 Signal flow

The following example shows which parameters influence the measured value from the analog input to the analog output.

### Analog input

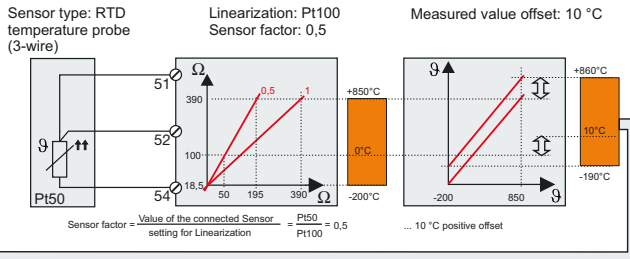

### Analog output

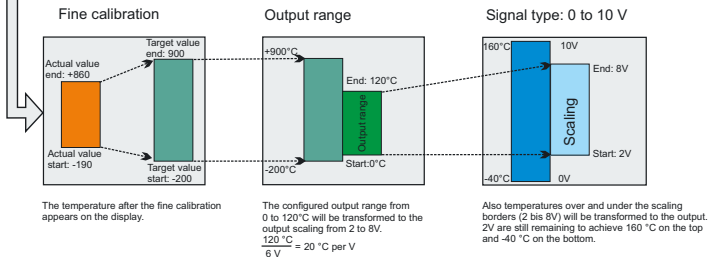

Here is a summary of the parameters from the figure above:

### ▾ Analog input:

Sensor type:	RTD temperature probe (3-wire)
Linearization:	Pt100, IEC 60751:2008, ITS-90
Noise suppression:	no
Sensor factor:	0.50
Filter time constant:	0.1 s
Measured value offset:	10.00 °C
Fine adjustment	
Fine adjustment start value (actual):	-190.00 °C
Fine adjustment end value (actual):	860.00 °C
Fine adjustment start value (target):	-200.00 °C
Fine adjustment end value (target):	900.00 °C

### ▾ Analog output:

Signal type:	0 ... 10 V
Output range start:	0.00 °C
Output range end:	120.00 °C
Scaling start:	2.00 V
Scaling end:	8.00 V
Simulation:	off
Reversion of the output:	No reversion
Error signal:	Negative signaling
Replacement value:	-0.20 V



## 6 Safety Manual



### Warning

All safety relevant parameters must be validated by the plant operator. In devices with extra code 058 the SIL operation is activated per default.

The settings for SIL operation are described in Chapter 5.3 and the default settings in Chapter 7 are marked (**bold**) and SIL-Parameter are marked yellow (printed in grey). Via Setup-program the data can be read from the device and after verification of the Parameter overview transferred back into the device.

Parameter	Value
Sensor type	RTD temperature probe (2-wire)
Linearization	Pt100IEC 60751:2008ITS-90
Temperature difference	10 °C
Temperature compensation	Internal
Fixed value	0.00 °C
Resistance measuring range	400 Ohm
Line resistance	0.0 Ohm
Sensor factor	1.00
Scaling start	0.00 *

### 6.1 Brief description, intended use

⇒ Chapter 1 "Brief description".

## 6.2 Validity of the safety manual



### Note

The evaluation described in this safety manual in terms of functional safety and display of certificates is valid for the specified transmitter in SIL operation, including probe versions.

⇒ Safety manual (probe for connection to 707071 Variant 1 and 2)

## 6.3 Special operating statuses

### 6.3.1 Behavior after a power failure

Analog output issues  $\leq 3.6$  mA; relay output (extra code 018) limit value is deactivated.

After the return of the mains voltage, the device starts as described in Chapter 5 and converts the measured value at the analog input in the configured output signal.

### 6.3.2 During setup data transfer

If LED illuminates  simultaneously red and green, the device is transferred to a safe state until the setup data reaches the device and a data comparison is carried out.

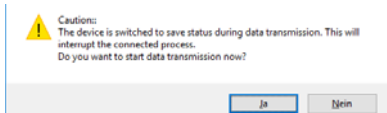

### 6.3.3 After alteration of the configuration level (at the device or through setup)

The device carries out a plausibility check that can also trigger an error message.

⇒ Chapter 12 "What to do, if ..." "Check dependent parameters"

⇒ Chapter 11 "Error messages"

### 6.3.4 Issue of an error signal (safe state)

In SIL operation, the measured value at the analog input is always issued at the analog output 4 to 20 mA.

The limit values according to Namur NE 43 ( $\leq 3.6$  or  $\geq 21$  mA) are only issued when internal errors and probe errors are identified. However, the behavior of the analog output in case of limit value errors is configurable.

⇒ Chapter 7.5.8 "Response for limit error"

## 6.4 Relevant standards

Type 707071 SIL fulfills the requirements for SIL 2, or SIL 3 in redundant use, according to DIN EN 61508 and PL c/PL d according to DIN EN ISO 13849-1, as well as the requirements of DIN EN 60730-2-9.

The systematic suitability is defined at SC = 3 for HW and SW.

This means that SIL 2 or PL c for HFT = 0 (individual device) and SIL 3 or PL d for HFT = 1 (2 devices) are achieved.

For the safety function up to SIL 3 according to DIN EN 61508 Part 1 to 7:

Functional safety of electrical/electronic/programmable electronic safety-related systems

DIN EN 60730-2-9:

Automatic electrical controls for household and similar use – Part 2-9: Particular requirements for temperature sensing controls

DIN EN ISO 13849-1:

Safety of machinery - Safety-related parts of control systems - Part 1: General design guidelines

DIN EN ISO 13849-2:

Safety of machinery - Safety-related parts of control systems - Part 2: Validation (ISO 13849-2)

## 6.5 Connection possibilities of the sensors

Variant	connected Sensors
Variant 1	RTD temperature probe in a 2-, 3- or 4-wire circuit
Variant 2	double thermocouple
Variant 3	4 to 20 mA

## 6.5.1 Terms and abbreviations according to DIN EN 61508 and DIN EN 61511.

Name	Description
Actuator	Part of a safety-related system that intervenes in the process to achieve a safe state.
EUC	EUC (equipment under control) Equipment, machine, apparatus, or system used for manufacturing, shaping materials, for transport, medical purposes, or other activities.
E/E/PE	Electrical/electronic/programmable electronic (E/E/PE): based on electrical (E) and/or electronic (E) and/or programmable electronic (PE) technology
Failure	End of the ability of a functional unit to perform a required function.
Diagnostic coverage	Partial reduction in the probability of critical hardware failures due to the use of automatic diagnostic tests.
Error	An abnormal condition that can cause a reduction or the loss of the ability of a functional unit to perform a required function.
Functional safety	A part of overall safety related to the EUC and EUC control system that depends on the proper function of the E/E/EP safety-relevant system, safety-relevant systems of other technology, and external equipment for risk reduction.
Functional unit	Unit consisting of hardware or software or both that is suitable for performing a specified task.
Dangerous failure	Failure of an element and/or subsystem, and/or system involved in implementing the safety function, which  a) prevents the safety function being executed on demand (on-demand operation type), or causes the failure of a safety function (operation with continuous demand), so that the EUC transitions to a dangerous or potentially dangerous state; or  b) reduces the probability of executing the safety function correctly on demand.

Name	Description
Safe failure	Failure of an element and/or subsystem, and/or system involved in implementing the safety function, which a) causes false triggering of the safety function, switching the EUC (or parts of it) to a safe state, or maintaining a safe state; or a) increases the probability of false triggering of the safety function, switching the EUC (or parts of it) to a safe state, or maintaining a safe state.
Hazard	Potential source of damage
Safety	Freedom from unreasonable risk
Safety function	A function that is performed by an E/E/PE safety-related system, safety-related system based on other technology, or external equipment for reducing risk with the goal of achieving or maintaining a safe state for the EUC taking into consideration a specified dangerous event
Safety integrity	The probability of a safety-related system performing the required safety function under all specified conditions within a specified period of time according to requirements.
Safety integrity level (SIL)	One of four discrete levels for specifying the requirement for safety integrity of the safety functions assigned to the E/E/PE safety-related system. Safety integrity level 4 represents the highest level of safety integrity, while safety integrity level 1 represents the lowest.
Safety-related system	System that both - performs the required safety functions that are necessary to achieve or maintain a safe state for the EUC, and - is intended to achieve the necessary safety integrity for the required safety functions on its own or with other E/E/PE safety-related systems, safety-related systems of other technology, or external equipment for risk reduction.
Safety instrumented system (SIS)	Safety instrumented system to perform one or more safety-related functions. A SIS consists of sensor(s), logic system, and actuator(s).
Lambda $\lambda$	Failure rate per hour
Lambda <b>D</b> angerous: $\lambda_D$	Rate of dangerous failures per hour
Lambda <b>D</b> angerous <b>D</b> etect: $\lambda_{DD}$	Rate of detected dangerous failures per hour

<b>Name</b>	<b>Description</b>
Lambda <b>D</b> angerous <b>U</b> ndetect: $\lambda_{DU}$	Rate of undetected dangerous failures per hour
Lambda Safe: $\lambda_S$	Rate of safe failures per hour
Lambda Safe <b>D</b> etect: $\lambda_{SD}$	Rate of detected safe failures per hour
Lambda Safe <b>U</b> ndetect: $\lambda_{SU}$	Rate of undetected safe failures per hour
BPCS	Basic process control system
DC	<b>D</b> iagnostic <b>c</b> overage
FIT	<b>F</b> ailure in <b>t</b> ime ( $1 \times 10^{-9}$ per h)
HFT	<b>H</b> ardware <b>f</b> ailure <b>t</b> olerance
PFD	<b>P</b> robability of <b>f</b> ailure on <b>d</b> emand
PFD <sub>avg</sub>	<b>P</b> robability of <b>f</b> ailure on <b>d</b> emand <b>a</b> verage
PFH	Probability of dangerous failure per hour
MooN	Architecture with M from N channels
MTBF	<b>M</b> ean <b>t</b> ime <b>b</b> etween <b>f</b> ailures
MTTR	<b>M</b> ean <b>t</b> ime <b>t</b> o <b>r</b> estoration (mean time between discovery of the fault and repair of the system)
MRT	<b>M</b> ean <b>r</b> epair <b>t</b> ime (mean time to repair the system)
SFF	<b>S</b> afe <b>f</b> ailure <b>f</b> raction
SIL	<b>S</b> afety <b>i</b> ntegrity <b>l</b> evel
SC	<b>S</b> ystematic <b>c</b> apability
PTC	<b>P</b> roof <b>t</b> est <b>c</b> overage (diagnostic coverage during repeat test)
T <sub>i</sub>	Proof <b>T</b> est intervall

### 6.5.2 Safety-relevant parameters

All following informations relate to the connection-**Variant 3**.

The following parameters were calculated using the formular in Chapter 6.5.5 for  $T_i = 1, 3, \text{ and } 5$  years.

### 6.5.3 Failure rates and SFF for 707071/X – 23/XXX (AC240V)

<b>Variant 3</b> 4 to 20 mA (without sensor technology 1oo1D architecture)	$\lambda_S$ [FIT]	$\lambda_{DD}$ [FIT]	$\lambda_{DU}$ [FIT]	SFF	PFH (1/h)	PFD <sub>avg</sub> (Proof test A PTC=76.2%)	PFD <sub>avg</sub> (Proof test B PTC=70.4 %)	PFD <sub>avg</sub> (Proof test C PTC=45.6 %)
$T_i = 1$ year	49,5	2106,0	159,1	93 %	$1,59 \times 10^{-7}$	$2,35 \times 10^{-3}$	$2,71 \times 10^{-3}$	$4,27 \times 10^{-3}$
$T_i = 3$ years						$3,41 \times 10^{-3}$	$3,70 \times 10^{-3}$	$4,90 \times 10^{-3}$
$T_i = 5$ years						$4,48 \times 10^{-3}$	$4,68 \times 10^{-3}$	$5,54 \times 10^{-3}$

■ see examples in Chapter 6.5.5

### 6.5.4 Failure rates and SSF for 707071/X – 29/XXX (DC24V)

<b>Variant 3</b> 4 to 20 mA (without sensor technology 1oo1D architecture)	$\lambda_S$ [FIT]	$\lambda_{DD}$ [FIT]	$\lambda_{DU}$ [FIT]	SFF	PFH (1/h)	PFD <sub>avg</sub> (Proof test A PTC=71.3 %)	PFD <sub>avg</sub> (Proof test B PTC=67.3 %)	PFD <sub>avg</sub> (Proof test C PTC=44.2 %)
$T_i = 1$ year	49,5	2144,9	166,2	93 %	$1,66 \times 10^{-7}$	$2,77 \times 10^{-3}$	$3,03 \times 10^{-3}$	$4,54 \times 10^{-3}$
$T_i = 3$ years						$3,81 \times 10^{-3}$	$4,01 \times 10^{-3}$	$5,18 \times 10^{-3}$
$T_i = 5$ years						$4,85 \times 10^{-3}$	$4,99 \times 10^{-3}$	$5,83 \times 10^{-3}$

## 6.5.5 Calculation of PFD<sub>avg</sub>

The operator defines the following topics:

- Proof test interval  $T_i$
- Planned operating duration mission time  $T_M$  and
- the PTC-value for the performed Proof test (A,B or C)

The mission time  $T_M$  has to be at least equal the time for the proof test interval  $T_i$ , but not exceed the Lifetime of 10 years. This must be taken into consideration when evaluating the probability of a dangerous failure PFD<sub>avg</sub> of the sensor system. In the case of a single-channel system architecture, the mean probability of a dangerous failure PFD<sub>avg</sub> of the transmitter can be calculated from the following formula:

**Formula:**

$PFD_{avg} = \lambda_{dd} \cdot MTTR + PTC \cdot \lambda_{du} \cdot \left( \frac{T_i}{2} + MRT \right) + (1 - PTC) \cdot \lambda_{du} \cdot \frac{T_M}{2}$	
$\lambda_{dd}$	Rate of detected dangerous failures per hour
$\lambda_{du}$	Rate of undetected dangerous failures per hour
MTTR	<b>M</b> ean <b>T</b> ime <b>T</b> o <b>R</b> estoration, (mean time between discovery of the fault and repair of the system)
PTC	<b>P</b> roof <b>T</b> est <b>C</b> overage (diagnostic coverage during repeat test)
$T_i$	Proof <b>T</b> est <b>I</b> nterval (Interval that can be defined by the the plant operator)
MRT	<b>M</b> ean <b>R</b> epair <b>T</b> ime (mean time to repair the system)
$T_M$	<b>M</b> ission <b>T</b> ime, Planned operating duration (10 years = 87600 hours)

Type 707071, 240V, without sensor, examples:

Proof test	$\lambda_{dd}$ [Fit]	$\lambda_{du}$ [Fit]	MTTR [h]	PTC [%]	$T_i$ [h]	MRT [h]	$T_M$ [h]	PFD <sub>avg</sub>
A	2106	159,1	72	76,2	8760	72	87600	$2,35 \cdot 10^{-3}$
	$\text{PFD}_{\text{avg}} = 2106,0 \cdot 10^{-9} \frac{1}{h} \cdot 72 \text{ h} + 0,762 \cdot 159,1 \cdot 10^{-9} \frac{1}{h} \left( \frac{8760 \text{ h}}{2} + 72 \text{ h} \right) + (1 - 0,762) \cdot 159,1 \cdot 10^{-9} \frac{1}{h} \cdot \frac{87600 \text{ h}}{2} = 2,35 \cdot 10^{-3}$							
B	2106	159,1	72	70,4	8760	72	87600	$2,71 \cdot 10^{-3}$
	$\text{PFD}_{\text{avg}} = 2106,0 \cdot 10^{-9} \frac{1}{h} \cdot 72 \text{ h} + 0,704 \cdot 159,1 \cdot 10^{-9} \frac{1}{h} \left( \frac{8760 \text{ h}}{2} + 72 \text{ h} \right) + (1 - 0,704) \cdot 159,1 \cdot 10^{-9} \frac{1}{h} \cdot \frac{87600 \text{ h}}{2} = 2,71 \cdot 10^{-3}$							
C	2106	159,1	72	45,6	8760	72	87600	$4,27 \cdot 10^{-3}$
	$\text{PFD}_{\text{avg}} = 2106,0 \cdot 10^{-9} \frac{1}{h} \cdot 72 \text{ h} + 0,456 \cdot 159,1 \cdot 10^{-9} \frac{1}{h} \left( \frac{8760 \text{ h}}{2} + 72 \text{ h} \right) + (1 - 0,456) \cdot 159,1 \cdot 10^{-9} \frac{1}{h} \cdot \frac{87600 \text{ h}}{2} = 4,27 \cdot 10^{-3}$							

Information:  $1 \text{ Fit} = 1 \cdot 10^{-9} \frac{1}{h}$

## 6.6 Determining the safety integrity level (SIL)

The achievable safety integrity level is determined by the following safety-related parameters:

- Average probability of dangerous failures of a safety function on demand ( $PFD_{avg}$ ),
- Hardware fault tolerance (HFT) and
- Safe failure fraction (SFF).

The specific safety-related parameters for the 707071 measuring system can be found in the table in the "Safety-related parameters" chapter. They apply to the instrument with extra code 018 and 058.

The following table shows how the "safety integrity level" (SIL) depends on the "average probability of dangerous failures of a safety function of the entire safety-related system" ( $PFD_{avg}$ ) according to DIN EN 61508. The "low demand mode" is considered here, i.e. the demand rate for the safety-related system averages once a year.

Table for high demand PFH and low demand PFD

Safety integrity level (SIL)	Operating mode with high demand rate <b>PFH</b> (high demand mode)	Operating mode with low demand rate <b>PFD<sub>avg</sub></b> (low demand mode)
4	$\geq 10^{-9}$ to $<10^{-8}$	$\geq 10^{-5}$ to $<10^{-4}$
3	$\geq 10^{-8}$ to $<10^{-7}$	$\geq 10^{-4}$ to $<10^{-3}$
2	$\geq 10^{-7}$ to $<10^{-6}$	$\geq 10^{-3}$ to $<10^{-2}$
1	$\geq 10^{-6}$ to $<10^{-5}$	$\geq 10^{-2}$ to $<10^{-1}$

### 6.6.1 Safety integrity of the hardware

According to DIN EN 61508, a distinction must be made between systems of type A and systems of type B.

A subsystem can be considered to be type A if, for the components required to achieve the safety function,

- the failure behavior of all components used is sufficiently defined, and
- the behavior of the subsystem can be fully determined under error conditions; and
- reliable failure data from experience in the field exists for the subsystem to show that the assumed failure rates for detected and undetected dangerous failures are achieved.

A subsystem can be considered to be type B if, for the components required to achieve the safety function,

- the failure behavior of at least one of the components used is not sufficiently defined, or
- the behavior of the subsystem cannot be fully determined under error conditions, or
- no sufficiently reliable failure data from experience in the field exists for the subsystem to support the utilized failure rates for detected and undetected dangerous failures.

The type 707071 transmitter corresponds to a type B system.

The following table shows the achievable safety integrity level (SIL) depending on the safe failure fraction (SFF) and the hardware fault tolerance (HFT) for safety-related type B subsystems.

For 707071 the following table applies:

Safe failure fraction (SFF)	Hardware fault tolerance (HFT) for type B		
	0	1	2
<60 %	Not allowed	SIL 1	SIL 2
60 to <90 %	SIL 1	SIL 2	SIL 3
90 to <99 %	SIL 2	SIL 3	SIL 4
≥ 99 %	SIL 3	SIL 4	SIL 4

## 6.6.2 Safety-relevant system properties

The type 707071 transmitter is realized as a 1oo1D architecture.

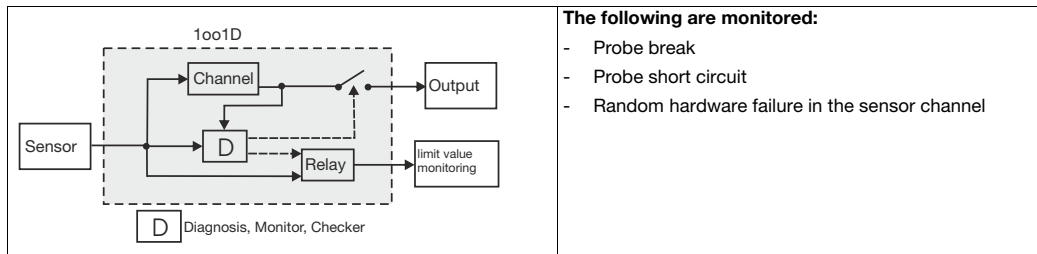

Safety feature	Requirement / comment
SIL	SIL2
Systematic suitability of HW and SW	SC3
Operating mode in terms of safety function	Operating mode with low and high demand rate possible on a customer-specific basis
Safety-critical inputs	Temperature sensor input for double thermocouple and RTD temperature probe with 2, 3, and 4-wire technology, 4-20 mA current input
Overall safety accuracy	The defined value for the accuracy of the safety function of this device is $\pm 3.5\%$ of 20 mA.
Safety-relevant inputs	Setup and parameterization
Safety-critical output	Analog output 4 to 20 mA Relay output (extra code 018)

Safety feature	Requirement / comment
Subsystem type	Type B
707071 safety architecture	1oo1D This corresponds to architecture category 2 according to DIN EN ISO 13849, i.e. the system has a safety channel and an additional diagnostics channel.
Hardware failure tolerance	HFT = 0
Safe failure fraction	SFF $\geq$ 90 %
CCF	If the system is used redundantly: calculation according to DIN EN 61508 Part 7 Appendix D and/or DIN EN ISO 13849-1 Table F.1 at least 65
Average failure probability of a safety function on demand (overall system)	SIL 2: Low demand: $PFD_{avg} < 10^{-2}$ High demand: $PFH < 10^{-6}$
Interval for the proof test $T_i$	max. 10 years
Lifetime	10 years
Planned operating duration Mission time ( $T_M$ )	max. 10 years
Architecture according to DIN EN ISO 13849-1	Category 2
$MTTF_{d-DC_{avg}}$ according to DIN EN ISO 13849-1 Table K.1	PL c: $\geq$ 22 years ( $DC_{avg} \geq$ 60 %)
Modes of operation and software class according to DIN EN 60730-2-9	The system has the following modes of operation: 2K Only in the case of redundancy: 2N Software class C

### 6.6.3 Redundant use of the system

If the transmitter is used redundantly (HFT > 0), it can meet SIL 3 according to DIN EN 61508-2, 7.4.3.2 (systematic suitability) and 7.4.4.2.4 (suitability of the architecture).

SIL of the used Sensor	systematic capability (SC) of the used Sensor	max. achievable SIL of the system with 1oo1 sensor system and temperature transmitter architecture	max. achievable SIL of the system in redundant use (HFT = 1) of Sensor and temperature transmitter
1	1	1	1
1	2	1	2
2	2	2	2
2	3	2	3
3	3	2	3

#### 6.6.4 Sensor connection possibilities

The connection of RTD temperature probes with 2, 3, and 4-wire technology or double thermocouples is described in the safety manual (probe for connection to 707071 Variant 1 and 2).

#### 6.7 Determining the achieved performance level PL

The following safety-related parameters are required to determine the performance level of components/devices:

As further parameters to be observed, operational aspects such as the demand rate and/or the test rate of the safety function can also influence the resulting PL.

Excerpt from DIN EN ISO 13849-1



##### Note

This excerpt contains references to the complete standard DIN EN ISO 13849-1, which are therefore not reproduced in this chapter

## 6.7.1 Terms and abbreviations according to standards series DIN EN ISO 13849

Formula symbol or abbreviation	Description	Definition or location
PL (a, b, c, d, e)	Designation for the performance level	Table 3 in DIN EN ISO13849-1
AOPD	Active opto-electronic protective device (e.g. light barrier)	Annex H
B, 1, 2, 3, 4	Designation for the categories	Table 7
$B_{10d}$	Number of cycles in which a dangerous failure occurred in 10 % of a random sample of the observed pneumatic or electromechanical components that are subject to wear (mean time to dangerous failure)	Annex C
Cat.	Category	3.1.2
CC	Current converter	Annex I
CCF	<b>C</b> ommon <b>c</b> ause <b>f</b> ailure	3.1.6
DC	<b>D</b> iagnostic <b>c</b> overage	3.1.26
$DC_{avg}$	Average diagnostic coverage	E.2
MTTF	Mean time to failure	Annex C
$MTTF_c$	Mean time to critical failure	3.1.25
$MTTF_d$	Mean time to dangerous failure	
n, N, $\bar{N}$	Number of units	6.3, D.1
$M_{low}$	Number of SRP/CS with $PL_{low}$ in an SRP/CS combination	6.3
PL	Performance level	3.1.23
PLC	Programmable logic controller	Annex I
$PL_{low}$	Lowest performance level of an SRP/CS in an SRP/CS combination	6.3

Formula symbol or abbreviation	Description	Definition or location
$PL_f$	Required performance level	3.1.24
$T_M$	<b>Mission time</b> (functional life, designated period of utilization)	3.1.28
$T_{10d}$ -value	Reference value for a preventative replacement (10 % of the B10d value). At this value, a dangerous failure has already occurred for approx. 63 % of all components. In this case, the standard DIN EN ISO 13849-1 recommends replacement.	

The following table shows the achievable PL level for the two voltage versions each with relay output (extra code 018):

### 6.7.2 Calculations of the DIN EN ISO 13849-1 performance level – 707071/X - 23/XXX (AC240V)

Variant	$MTTF_d$	$DC_{avg}$	CCF	PL
4 to 20 mA also with relay output (without sensor technology 1oo1D architecture)	52 years	93.54 %	75 points	PL c

### 6.7.3 Calculations of the DIN EN ISO 13849-1 performance level – 707071/X - 29/XXX (DC24V)

Variant	$MTTF_d$	$DC_{avg}$	CCF	PL
4 to 20 mA also with relay output (without sensor technology 1oo1D architecture)	51 years	93.28 %	75 points	PL c

The two variants of the dTRANS T06 meet the architecture requirements for a category 2 system. The necessary limit values according to DIN EN ISO 13849-1, Table K.1 for **performance level c** and the fundamental and established safety principals are adhered to for all voltage versions of type 707071 considered.

If the temperature transmitter is used redundantly (i.e. HFT = 1), the requirements for a category 3 system are adhered to. The

necessary limit values according to DIN EN ISO 13849-1, Table K.1 for **performance level d** are met here for both voltage versions.

The following chart can be used to determine the PL if the  $MTTF_d$  value of the sensor is 100 years. The reached DC for identifying the errors of the sensor of the temperature transmitter will be calculated at (HFT = 1) with  $\geq 60\%$  in a redundant application.

PL of the used Sensor $MTTF_d=100$ years	max. achievable PL of the system with 1oo1 architecture	max. achievable PL of the system in redundant use (HFT = 1) $DC \geq 60\%$
b	b	d
c	c	d
d	c	d
e	c	d

#### 6.7.4 Risk reduction through the control system

In order to meet safety aims for the machine, the entire design process must be followed. The design of the SRP/CS (safety-related part of a control system) is a necessary part of the entire design process in order to provide the risk reduction required. This can only be achieved with a PL that achieves the required risk reduction. By installing a protective guard or protective device, the design of the SRP/CS is part of the risk reduction strategy.

The features of each safety function (see section 5) and the required performance level must be described and documented in the specification of the safety requirements.

In this part of DIN EN ISO 13849-1, the performance levels are defined in the form of the probability of a dangerous failure per hour. Five performance levels (a to e) have been specified (see Table).

Performance level (PL)	Average probability of a dangerous failure per hour 1/h
a	$\geq 10^{-5}$ to $< 10^{-4}$
b	$\geq 3 \times 10^{-6}$ to $< 10^{-5}$

Performance level (PL)	Average probability of a dangerous failure per hour 1/h
c	$\geq 10^{-6}$ to $< 3 \times 10^{-6}$
d	$\geq 10^{-7}$ to $< 10^{-6}$
e	$\geq 10^{-8}$ to $< 10^{-7}$
NOTE: in addition to the average probability of a dangerous failure per hour, further measures are required to achieve the PL.	

## 6.8 Other applicable device documentation

For the transmitter type 707071, the measures, values, and requirements specified in this operating manual regarding installation, electrical connection, function, and startup must be observed.

## 6.9 Behavior during operation and in case of malfunction

The behavior during operation is described in Chapter 5 "Startup of the device" and in case of malfunction is described in Chapter 11 "Error messages".

A functional test must be performed after startup, repair in the safety system, or a change in safety-related parameters.

If an error is detected during a functional test, measures must be taken to once again ensure the functional capability of the safety system. This, for example, can be done by replacing the logic unit.

Appropriate documentation of the tests performed is recommended.

## 6.10 Regular tests

The device test can be carried out as follows:

- Proof test A: complete test by the manufacturer; the device must be sent to the manufacturer for this purpose.
- Proof test B: comprehensive test; the device must be removed from the operating facility for this purpose.
- Proof test C: simplified test; the device can remain in the operating facility for this purpose.

Depending on the voltage supply of the device, different values occur for the proof test coverage (PTC):

### 6.10.1 Proof test A

(corresponds to factory calibration)

For a complete check, the device must be removed from the operating facility and sent to the manufacturer.

⇒ For service addresses see back cover

Voltage supply	Detection of dangerous undetected failures ( $\lambda_{DU}$ )	PTC
AC 110 to 240 V +10/-15 %, 48 to 63 Hz	0.750	75 %
DC 24 V +10/-15 %	0.699	69.9 %

## 6.10.2 Proof test B

Step	Action	Please note
1	Disconnect all test piece connections. Test the resistance between the following connections with an ohmmeter: 21 to 22: low-resistance, 0 $\Omega$ 21 to 23: high-resistance, ohmmeter overrun 22 to 23: high-resistance, ohmmeter overrun	Test piece is completely disconnected from the operating facility and without power supply. Verification that there is no short circuit in the area of connections 21 to 23 and 22 to 23.
2	Test the resistance between the following connections with an ohmmeter: 41 to 42: > 10 k $\Omega$	Verification that there is no short circuit in the area of the analog output connection terminal.
3	Test the resistance between the following connections with an ohmmeter: 52 to 51: > 10 k $\Omega$ 53 to 51: > 10 k $\Omega$ 54 to 51: > 10 k $\Omega$ 53 to 52: > 10 k $\Omega$ 54 to 52: > 10 k $\Omega$ 54 to 53: > 10 k $\Omega$	Verification that there is no short circuit in the area of the measurement input connection terminal.
4	Connect short-circuit jumper between connection 41(+) and connection 42(-), restore energy supply connection and switch on test piece, configure test piece for connection to RTD temperature probe sensor type in 4-wire connection and configure analog output for current signal (4 mA to 20 mA; error signal: negative signaling). Connect current meter between connection 54(+) and 51(-) and measure the current: 200 $\mu$ A to 300 $\mu$ A can be expected.	Verification that components determining the current are OK.

Step	Action	Please note
5	<p>Connect resistance decade for simulation of the input signal that is appropriate for the chosen configuration. Verify whether the expected value (display value) corresponds to the input signal.</p> <p>Test the current device status of the test piece using the setup program. Status must be 'OK'.</p> <p>If, for example, Pt100 is configured, 0 °C must be displayed at the input at 100 Ω.</p>	Verification that there is no error status internally if display correct without error signaling.
6	Produce line break for each of the 4 lines. The test piece must signal an error (display and LED).	Verification of proper function of the probe break/line break detection.
7	<p>Switch off test piece and replace short-circuit jumper at the analog output with the current meter; connection 41(+) and connection 42(-).</p> <p>Switch on test piece again.</p> <p>Check output signal by applying a corresponding reference signal using a resistance decade at two points; for the start of measurement (measuring range start up to +20 % of the range) and for the end of measurement (measuring range end up to -20 % of the range).</p> <p>The analog output signal corresponding to the reference signal must be within the safety measurement deviation.</p> <p>Furthermore, the display value must correspond to the reference signal according to the configuration.</p>	Verification that the measuring chain for RTD is within the safety measurement deviation.

Step	Action	Please note
8	<p>Set limit value of the relay (function AF7) in the middle of the configured measuring range. Connect positive terminal of a voltage source (24 V <math>\pm</math>5 %, 500 mA) to the terminal connection 22 via a resistor (240 <math>\Omega</math>, 5 W).</p> <p>Connect the ground connection of the voltage source with the relay contact connections 21 and 23.</p> <p>Simulate an input signal close to the measuring range start using a resistance decade, and verify whether the specified signal and the transformed analog output signal correspond to the value expected (display value, current meter).</p> <p>Measure the voltage between the connections 22(+) and 21(-), as well as between 22(+) and 23(-) using the voltage meter.</p> <p>The measured voltage value between terminals 22 and 21 must be &lt; 0.1 V, and must be 22.8 V to 25.2 V between terminals 22 and 23.</p>	<p>Verification that the relay has not switched <b>below</b> the configured limit value.</p>
9	<p>Simulate an input signal close to the measuring range end using a resistance decade, and verify that the input signal corresponds to the value expected (display value). Measure the voltage between the connections 22(+) and 21(-), as well as between 22(+) and 23(-) using the voltage meter. The measured voltage value between terminals 22 and 21 must be 22.8 V to 25.2 V, and be &lt; 0.1 V between terminals 22 and 23.</p>	<p>Verification that the relay has not switched <b>above</b> the configured limit value.</p>
10	<p>Disconnect line to the measurement input connection 51. The test piece must signal an error (display and LED). The current meter must display a value <math>\leq</math> 3.6 mA as an analog output signal. Measure the voltage between the connections 22(+) and 21(-), as well as between 22(+) and 23(-) using the voltage meter. The measured voltage value between 22 and 21 must be &lt; 0.1 V, and must be 22.8 V to 25.2 V between 22 and 23.</p> <p>The relay therefore drops out.</p>	<p>Verification in the event of a malfunction that the analog output signal corresponds to failure information A, NE43, and the relay has dropped out.</p>

Step	Action	Please note
11	<p>Restore line to the measurement input connection 51. Both the display and the current meter at the analog output must display values that correspond to the input signal present close to the measuring range end. Relay must have picked up. The test piece must be in SIL operation and/or have a SIL configuration.</p> <p>Disconnect the line of the current meter at connection 42(+). The test piece must signal an error after approx. 5 s. Measure the voltage between the connections 22(+) and 21(-), as well as between 22(+) and 23(-) using the voltage meter. The measured voltage value between 22 and 21 must be &lt; 0.1 V, and must be 22.8 V to 25.2 V between 22 and 23.</p>	<p>Verification that in the event of interruption of the output signal path (current signal), the internal test for a correct output signal identifies the interruption of the signal path and signals it. Relay drops out.</p>
12	<p>If active, deactivate SIL operation of the test piece.</p> <p>Configure test piece for connection to the thermocouple sensor type, NiCr-Ni, type 'K', internal cold junction, and configure analogue output to current signal (4 mA to 20 mA; error signal: negative signaling).</p> <p>Connect current meter between connection 54(+) and 51(-) and measure the current. No current must be measurable (<math>\sim 0 \mu\text{A}</math>).</p>	<p>Verification that the power source is switched off for the RTD temperature probe in the thermocouple configuration.</p>
13	<p>Connect short-circuit jumper between connection 52(+) and connection 51(-). Check whether the temperature displayed by the display corresponds to the ambient temperature with a deviation of <math>\pm 5 \text{ }^\circ\text{C}</math>.</p>	<p>Verification of proper function of the acquisition of the cold junction temperature for thermocouples.</p>
14	<p>Configure test piece for connection to the double thermocouple sensor type, NiCr-Ni, type 'K', internal cold junction, and configure analogue output to current signal (4 mA to 20 mA; error signal: negative signaling).</p> <p>Test the resistance between the following connections with an ohmmeter: 53 to 51: display &lt; 5 <math>\Omega</math></p>	<p>Verification of proper function of the earthing switch for the second thermocouple</p>

Step	Action	Please note
15	<p>Switch off test piece and connect current meter using a burden of 500 <math>\Omega</math> between connections 42(+) and 41(-).</p> <p>Switch on test piece and configure analog output for simulation of current output signal 21.2 mA.</p> <p>The output signal recorded using the current meter must be 21.18 mA to 21.22 mA.</p> <p>Configure analog output for simulation of current output signal 3.6 mA. The output signal recorded using the current meter must be 3.59 mA to 3.61 mA.</p>	<p>Verification that the output driver stage of the analog output can drive the maximum permissible burden.</p>

With proof test B, the following values for the proof test coverage (PTC) can be achieved:

Voltage supply	Detection of dangerous undetected failures ( $\lambda_{DU}$ )	<b>PTC</b>
AC 110 to 240 V +10/-15 %, 48 to 63 Hz	0.709	70.9 %
DC 24 V +10/-15 %	0.677	67.7 %

## 6.10.3 Proof test C

Step	Action	Please note	
1	Test the current device status of the test piece with the setup program. Status must be 'OK'		
2	If active, deactivate SIL operation of the test piece. Configure analog output for simulation of current output signal. Simulate the following output signal values and verify either using downstream devices in the operating facility or using a current meter that is additionally connected:	Verification of the proper function of the analog output including whether the error signal values can be generated.	
	Simulated value:		Measured value:
	3.6 mA		3.59 to 3.61 mA
	8 mA		7.99 to 8.01 mA
	16 mA		15.99 to 16.01 mA
	21.2 mA	21.19 to 21.21 mA	
3	Reactivate SIL operation. Disconnect the line of the analog output signal at connection 42(+). The test piece must signal an error after approx. 5 s. Verify that the relay output (extra code 018) has fallen.	Verification that in the event of interruption of the output current signal, the internal test identifies the interruption of the signal path and signals it. Relay drops out.	

With proof test C, the following values for the proof test coverage (PTC) can be achieved:

Voltage supply	Detection of dangerous undetected failures ( $\lambda_{DU}$ )	PTC
AC 110 to 240 V +10/-15 %, 48 to 63 Hz	0.454	45.4 %
DC 24 V +10/-15 %	0.440	44.0 %



### Warning

After the mission time expires, the systems no longer meet the requirements according to their SIL certification.

#### 6.10.4 Recommended tests for temperature probes

To ensure safe and reliable operation of the thermometers, the following service and maintenance work must be performed: The following tests are recommended at certain intervals:

- Every 12 months, the insulation resistance of the measuring circuit must be measured against the protection fitting (for thermocouples: only for the insulated measuring circuit; in the case of multiple measuring circuits, the insulation test must also be performed between the individual measuring circuits). The minimal insulation resistance at room temperature should be 100 M $\Omega$  at 100 V.
- Damage and corrosion of thermometers – protection tubes
- Corrosion and correct positioning of the contacts and terminals of cable connections
- Seals of terminal heads and cable bushings
- Interruptions due to "knocking" on the thermometer/measuring insert

Since the maximum operating temperature influences the drift behavior, the thermometer should be recalibrated or replaced at certain intervals to ensure reliable and precise temperature measurement.

The testing intervals are listed in the table below:

Maximum operating temperature	Pt – RTD temperature probe	Thermocouples
200 °C	5 years	5 years
550 °C	2 years	5 years
700 °C	1 year	2 years

1000 °C		Non-precious metal 1 year
		Precious metal 2 years
1500 °C		1 year

**Note**

The testing intervals for probes specified here are recommendations that must be adapted to the special conditions at the operating location and, if necessary, the user should perform the tests more regularly.



# 7 Configuration

## 7.1 Overview

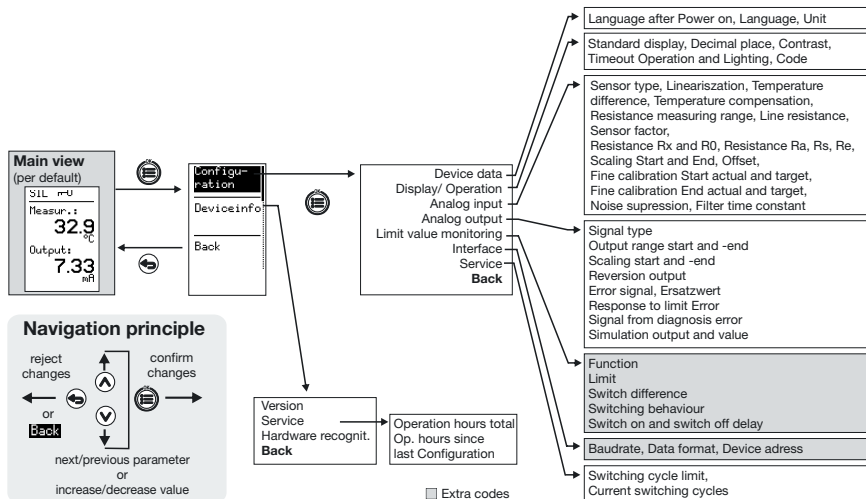

All the parameters are freely accessible, but they can be locked via a code on the device or with the setup program.

Default settings are shown in **bold**. All parameters are listed in the following tables.

Parameters which are not required are automatically hidden depending on the setting.

## 7.2 Device data

Parameter	Comment	Value range (default setting in <b>bold</b> )
<b>7.2.1 Language</b>	German	<b>German</b> , English, French, Spanish
	English	
	French	
	Spanish	
<b>7.2.2 Unit</b>	A unit for the measured value can be set here.	°C, °F, %, text
	°C	
	°F	
	%	
	Text: Via the setup program, 9 characters can be entered here for another unit, e.g. Pa (Pascal)	
<b>7.2.3 Language after power on</b>	Here you can select whether a language query should appear when the device is switched on.	<b>ON</b> , OFF

## 7.3 Display/operation

Parameter	Comment	Value range (default setting in <b>bold</b> )
7.3.1 Normal display	This sets the view that appears after the voltage supply is switched on. ⇒ Chapter 7.1 "Overview"	<b>Main view</b> , bar graph, limit value, drag indicator, TAG no. and info text, I/O info
	Main view	
	Bar graph	
	Limit value	
	Drag pointer	
	TAG no. and info text	
	I/O information  To display the connection diagram of sensor input, signal output, as well as the optional relay and interface assignment	
7.3.2 Decimal place	No decimal place	<b>None</b> , one, two
	One	
	Two	
7.3.3 Contrast	<b>Screen contrast:</b> Difference in brightness between black and white pixels	0 to <b>5</b> to 10

Parameter	Comment	Value range (default setting in <b>bold</b> )
<b>7.3.4 Lighting</b>	<p>Here, the background lighting of the display is set.</p> <p><b>Always off:</b> always switched off</p> <p><b>Always on:</b> always switched on</p> <p><b>When button is pressed:</b> The background lighting is only switched on when the keys are operated and it lights up until the time for the timeout backlight has expired.</p>	Always off, <b>Always on</b> , When button is pressed
<b>7.3.5 Time-out lighting</b>	This setting is only available for button-activated lighting. Here you can select how long the backlight should remain active after the last button operation.	0 to <b>30</b> to 100 sec
<b>7.3.6 Time-out operation</b>	<p>Here, the waiting period is set for the return from the configuration level to the normal display.</p> <p>⇒ See "Operating overview" on page 2.</p> <p>0 means: no automatic return to the normal display</p>	0 to <b>30</b> to 100 sec
<b>7.3.7 Code</b>	<p>To prevent unintentional changes to configuration data, a code for locking the configuration level can be set here.</p> <p>0 means: code request switched off</p> <p><b>Important information</b></p> <p> If the code is forgotten, a new code can be transferred to the device via the setup program.</p> <p>⇒ Chapter 10.3 "Forgotten the code?"</p>	0 to 9999

## 7.4 Analog input

Parameter	Comment	Value range (default setting in <b>bold</b> )
7.4.1 Sensor type	<b>RTD temperature probe in 2-wire circuit</b>	-
	RTD temperature probe in 3-wire circuit	-
	<b>RTD temperature probe in 4-wire circuit</b>	-
	Resistance/potentiometer in 2-wire circuit	-
	Resistance/potentiometer in 3-wire circuit	-
	Resistance/potentiometer in 4-wire circuit	-
	Resistance transmitter	-
	Thermocouple	-
	<b>Double thermocouple</b>	-
	mV input (0 to 1 V)	-
	<b>4 to 20 mA</b>	-
	0 to 20 mA	-
	0 to 10 V	-

■ SIL operation

<b>7.4.2 Linearization</b>	<b>Comment</b>	<b>Measuring range</b>
Linear	No sensor linearization	-
<b>Pt100</b>	<b>IEC 60751:2008</b>	<b>-200 to +850 °C</b>
Pt500, Pt1000	IEC 60751:2008	-200 to +850 °C
Pt50 GOST, Pt100 GOST	GOST 6651- 2009 A.2	-200 to +850 °C
Ni 100, Ni 500, Ni1000	DIN 43760:1987-09	-60 to +250 °C
Ni 100 GOST	GOST 6651-2009 A.5	-60 to +180 °C
Cu 50 GOST, Cu 100 GOST	GOST 6651-2009 A.3	-180 to +200 °C
Pt13Rh-Pt "R"	DIN EN 60584-1:2014	-50 to +1768 °C
Pt10Rh-Pt "S"		
Pt30Rh-Pt6Rh "B"		-50 to +1820 °C
Fe-CuNi "J"		-210 to +1200 °C
Cu-CuNi "T"		-200 to +400 °C
NiCr-Ni "E"		-200 to +1000 °C
NiCr-Ni "K"		-200 to +1300 °C
NiCrSi-NiSi "N"		-200 to +1300 °C
Fe-CuNi "L"	Thermocouple DIN 43710:1985-12	-200 to + 900 °C
Cu-CuNi "U"	Thermocouple DIN 43710:1985-12	-200 to +600 °C
Cromel COPEL® "L"	GOST R 8.585-2001	-200 to +800 °C
Cromel Alumel®		-270 to +1372 °C
W5Re-W20Re "A"	DIN EN 60584-1: 2014	-0 to +2500 °C
W5Re-W26Re "C"	DIN EN 60584-1: 2014	-0 to +2315 °C

7.4.2 Linearization	Comment	Measuring range
W3Re-W25Re "D"	ASTM E1751M-09 (up to 2315 °C): 2009	-0 to +2315 °C
Platinel type PLII		-0 to +1395 °C
Customer-specific	This setting only appears if a customer-specific linearization has been entered via the setup program and transferred to the device. ⇒ Chapter 10.4 "Kundenspezifische Linearisierung"	

Parameter	Comment	Value range (default setting in <b>bold</b> )
7.4.3 Temperature difference	This setting is only available if "double thermocouple" has been configured under linearization.	0 to <b>10</b> to 100
7.4.4 Temperature compens.		<b>Internal</b> , fixed value
7.4.5 Resistance measuring range	The measuring range can be selected here if "linear" or "customer-specific" has been set for linearization and "resistance/potentiometer" or "RTD temperature probe" has been set as the sensor type.	<b>400</b> , 4,000, 10,000 Ω
7.4.6 Line resistance	Resistance of probe line (for 2-wire circuit)	<b>0.0</b> to 100 Ω
7.4.7 Sensor factor	Only for RTD temperature probe: For adjusting Pt25 to Pt1000 sensors to a different set linearization (e.g. Pt100). For example, a Pt100 linearization can be corrected with the sensor factor 0.5 in order to connect a Pt50 sensor.	0.25 to <b>1.00</b> to 10.00

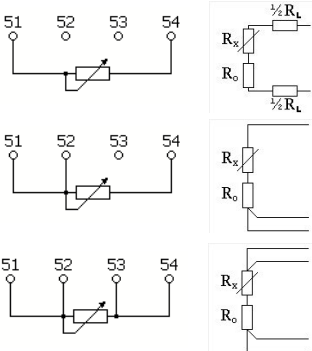
Parameter	Comment	Value range (default setting in <b>bold</b> )
<p><b>7.4.8 Resistance Rx</b></p> 	<p>Parameter appears for setting "resistance/potentiometer" with 2, 3 or 4-wire circuit Here, the total ohmic resistance of the potentiometer area covered must be entered.</p>	<p><b>0</b> to 400, 4,000 or 10,000 <math>\Omega</math></p>
<p><b>7.4.9 Line resistance RL</b></p>	<p>Here, the line resistance <math>R_L</math> (2-wire circuit) is entered.</p>	<p><b>0</b> to Rx</p>
<p><b>7.4.10 Resistance R0</b></p>	<p>Parameter appears for setting "resistance/potentiometer" with 2, 3 or 4-wire circuit. It may be that the potentiometer cannot reach 0 <math>\Omega</math> due to mechanical reasons. The starting resistance (e.g. left limit stop) of the potentiometer area is also entered here.</p>	<p><b>0</b> to 400, 4,000 or 10,000 <math>\Omega</math></p>

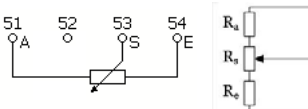
Parameter	Comment	Value range (default setting in <b>bold</b> )
<p><b>7.4.11 Resistance <math>R_A</math>, <math>R_S</math> and <math>R_E</math></b></p> 	<p>Dependent on the setting "resistance measuring range"</p> <p>Here, the starting resistance of the potentiometer must be entered. I.e. the resistance (between A and S) of the sliding contact at this position (e.g. left limit stop) must be entered.</p>	<p><b>0</b> to 400, 4,000 or 10,000 <math>\Omega</math></p>
<p><b>7.4.12 Scaling start</b></p>	<p>All sensor types can be scaled here if "linear" has been entered for linearization.</p>	<p>-5,000 to <b>0</b> to 50,000</p>
<p><b>7.4.13 Scaling end</b></p>		<p>-5,000 to <b>100</b> to 50,000</p>
<p><b>7.4.14 Offset</b></p>	<p>With the offset, the linearized/scaled measured value can be shifted evenly by the value entered over the entire measuring range.</p>	<p>-5,000 to <b>0.0</b> to 50,000 <math>^{\circ}\text{C}/^{\circ}\text{F}/\text{text}</math></p>
<p><b>7.4.15 Fine calibration start actual</b></p>	<p>You can use the fine adjustment to correct the measured values of the analog input. This may become necessary if the scaling and offset do not result in the desired display.</p> <p>⇒ Figure in Chapter 5.4 "Signal flow"</p>	<p>-5,000 to <b>0.0</b> to 50,000</p>
<p><b>7.4.16 Fine calibration end actual</b></p>		<p>-5,000 to <b>0.0</b> to 50,000</p>
<p><b>7.4.17 Fine calibration start target</b></p>		<p>-5,000 to <b>0.0</b> to 50,000</p>
<p><b>7.4.18 Fine calibration end target</b></p>		<p>-5,000 to <b>0.0</b> to 50,000</p>
<p><b>7.4.19 Noise suppression</b></p>	<p>Equalizes the input signals using the digital input filter.</p>	<p>Yes, <b>No</b></p>

Parameter	Comment	Value range (default setting in <b>bold</b> )
<b>7.4.20 Filter time constant</b>	<p><b>Time constant of the digital input filter</b>  <b>2nd order</b>            If the input signal changes suddenly, approx. 26 % of the change is recorded following a period that corresponds to the filter time constant <math>dF</math> (<math>2 \times dF</math>: approx. 59 %; <math>5 \times dF</math>: approx. 96 %).            Value 0 means: filter switched off</p> <p>If the filter time is long:            - Interfering signals are better absorbed            - Measured value display responds more slowly to changes</p>	0.0 to <b>0.1</b> to 100 sec

## 7.5 Analog output

Parameter	Comment	Value range (default setting in <b>bold</b> )
<b>7.5.1 Signal type</b>	Here, the standard signal for the analog output is set.	<b>4 to 20 mA,</b>
		0 to 20 mA
		2 to 10 V
		0 to 10 V
<b>7.5.2 Output range start</b>	Here, the output range of a temperature, resistance, current, or voltage measured value can be set (restricted). 0 to 120 °C is set in Chapter 5.4 "Signal flow".	Measuring range start to <b>0</b> to measuring range end
<b>7.5.3 Output range end</b>		Measuring range start to <b>100</b> to measuring range end

■ SIL operation

Parameter	Comment	Value range (default setting in <b>bold</b> )
<b>7.5.4 Scaling start</b>	Here, the output range set above is shown on the set scaling of the signal type. 2 to 8 V is set in Chapter 5.4 "Signal flow"	<b>4</b> to 20 mA, (the full range of the signal type above is applied per default)
<b>7.5.5 Scaling end</b>		0 to <b>20</b> mA
<b>7.5.6 Reversion output</b>	The signal at the output can be inverted here, e.g. for a setting of 0 °C = 0 V and 50 °C = 10 V, through the reversion this becomes 50 °C = 0 V and 0 °C = 10 V at the output	<b>No</b> , Yes
<b>7.5.7 Error signal</b>	If, for the measured value, the value is exceeded, not reached, or a diagnostic error occurs, the current or voltage value set on the analog output is output as a so-called error signal.	<b>Negative signaling</b> , positive signaling, replacement value
	For signal type 4 to 20 mA	<b>Low 3.6</b> or high 21.2 mA
	For signal type 0 to 20 mA	<b>Low -0.4</b> or high 21.2 mA
	For signal type 2 to 10 V	<b>Low 1.8</b> or high 10.6 V
For signal type 0 to 10 V	<b>Low -0.2</b> or high 10.6 V	
<b>7.5.8 Response for limit error</b>	Here you can select whether the analog output should also jump to the error value if the relay switches on "1" due to a limit value being exceeded or fallen short of.	<b>No error signal</b> , error signal
<b>7.5.9 Signal from diagnosis error</b>	Here you can select whether the device sets the analog output to an error value for all detected errors, or whether only device-relevant errors should be considered. This selection option only exists if there is a relay.	<b>All errors</b> , device-relevant errors

■ SIL operation

Parameter	Comment	Value range (default setting in <b>bold</b> )
<b>7.5.10 Simulation output</b>	An output current / output voltage can be simulated to test the following system. It is also possible to simulate residual currents/voltages.	<b>OFF</b> ON
<b>7.5.11 Simulation value</b>	This value is simulated. The value range depends on the set signal type.	for 0(4) to 20 mA; -0.4(3.6) to 21.2 mA,  for 0(2) to 10 V: -0.2(1.8) to 10.6 V

■ SIL operation

### 7.5.12 Behavior when leaving the scaling range

The standard signal ranges of the analog output are limited as follows according to the recommendation of NAMUR NE 43:

Signal type	Lower limit	Upper limit
4 to 20 mA	3.6 mA	21.2 mA
0 to 20 mA	-0.4 mA	21.2 mA
2 to 10 V	1.8 V	10.6 V
0 to 10 V	-0.2 V	10.6 V

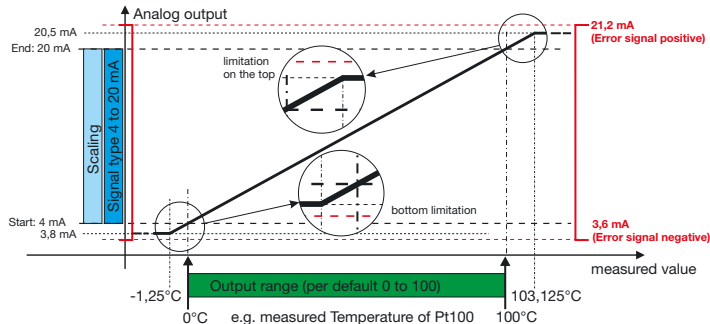

In this example, the measured value is output from 0 to 100°C at the analog output with 4 to 20 mA.



#### Caution

The analog output is **part of the safety function**.

## 7.6 Limit value monitoring

With this function, the relay output can monitor an adjustable limit value.

Depending on the set switching behavior, the relay output can switch to "1" or "0" in the event of limit value exceedance.

⇒ The limit value exceedance can also trigger a fault signal, see Chapter 7.5.8 "Response for limit error"

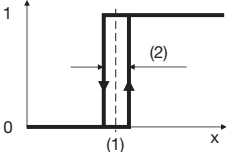
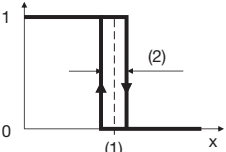
Parameter	Comment	Value range (default setting in <b>bold</b> )
<b>7.6.1 Function</b> (only for relay output option)	<b>Alarm function7 (AF7): ON electrical circuit from a fixed limit value</b>  <p>(1) Limit value (2) Switching differential</p>	<b>No function</b> AF7, AF8
	<b>Alarm function8 (AF8): OFF electrical circuit from a fixed limit value</b>  <p>(1) Limit value (2) Switching differential</p>	

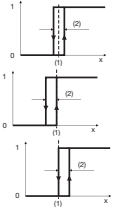
Parameter	Comment	Value range (default setting in <b>bold</b> )
<b>7.6.2 Limit value</b>	Here, the fixed switching point (1) is set.	Measuring range start to <b>0</b> to measuring range end in °C/°F/text
<b>7.6.3 Switch difference</b>	The switching differential determines the gap between the switch-on and switch-off threshold (2).	0 to <b>1</b> to 100 °C/°F/text
<b>7.6.4 Switching behavior</b>		<b>standard</b> ,  left,  right
<b>7.6.5 Switch on delay</b>	The relay only switches on or off after the entered time has elapsed.	<b>0</b> to 9999 s
<b>7.6.6 Switch off delay</b>		<b>0</b> to 9999 s

## 7.7 RS485 interface

Parameter	Comment	Value range (default setting in <b>bold</b> )
<b>7.7.1 Baud rate</b>	Protocol: Modbus slave	<b>9600</b> , 19200, 38400, 57600, 115200

Parameter	Comment	Value range (default setting in <b>bold</b> )
<b>7.7.2 Data format</b>	Data bits/stop bits/parity	<b>8/1/no parity</b> , 8/1/odd parity, 8/1/even parity, 8/2/no parity
<b>7.7.3 Device address</b>		<b>1</b> to 254

## 7.8 Service

Parameter	Comment	Value range (default setting in <b>bold</b> )
<b>7.8.1 Minimum meas. value</b>	Minimum measured value is displayed	
<b>7.8.2 Maximum meas. value</b>	Maximum measured value is displayed	
<b>7.8.3 Min.value reset</b>		<b>No</b> , Yes
<b>7.8.4 Max.value reset</b>		<b>No</b> , Yes
<b>7.8.5 Switching cycle limit</b>	<p><b>Limit value for relay switching cycles</b></p> <p>Here, the limit value for the admissible relay switching operations is set.</p> <p>If the counter value for <b>Current switching cycles</b> is greater than this value, the display values flash, the relay output alarm drops, and the analog output goes to the defined error value.</p> <p>If "0" is set the function is inactive.</p>	<b>0</b> to 29,999

Parameter	Comment	Value range (default setting in <b>bold</b> )
<b>7.8.6 Current switching cycles</b>	<b>Relay switching cycle counter</b> Here, the switching cycles for the relay are only counted if the top <b>limit value for relay switching cycles</b> is not set to "0" and is thus inactive.  The value can be adjusted as required and therefore adapted accordingly to the system, for example by setting it to 0 after start-up. The switching cycle counter remains at 30,000.	<b>0</b> to 30,000

## 8 Device info

### 8.1 Version

**Device software version channel:****Device software version diagnostics:****Fabrication number:**

The first 8 digits are the production order number: 02472588

Digit 9 and 10 manufacturing site Fulda: 01

Digit 11 (second row) device version: 0

Digit 12 and 13 year: 2018

Digit 14 and 15 calendar week: 11

Digit 16 to 19 consecutive number: 0003

**Inspection ID:****Extra code SIL:**

"No" means switched off, "Yes" means switched on.

⇒ Chapter and Chapter 10.6

Version	Version	Version	Version	Version
SW version channel	SW version channel	Serial No.	Check-ID	Type code SIL
348.01.01 t09	348.01.01	0247258801 018110003	05009719	Yes

The device software version channel, device software version diagnostics, fabrication number, inspection ID and the extra code SIL are displayed here.

## 8.2 Service

Parameter	Comment	Value range (default setting in <b>bold</b> )
<b>8.2.1 Operating hours total</b>	<p><b>Operating hours counter</b></p> <p>The counter adds up the operating hours during which the device was connected to the voltage supply.</p> <p>The value cannot be changed and can be used as a measure of how long the device was actually in operation after leaving the factory.</p>	<b>0</b> to 99999 hours
<b>8.2.2 Operating hours since last configuration</b>	<p><b>Operation time since the last change in the configuration level</b></p> <p>Here, the time is displayed for which the device was in operation after the last time the configuration level was left. This also applies for configuration via setup program.</p>	<b>0</b> to 99999 hours

## 8.3 Hardware recognition

The extra codes installed in the device are displayed here.

Hardware recognit.	Hardware recognit.
Option relay	Option RS485
Fitted	Fitted



## 9 Technical data

### 9.1 Analog input

#### 9.1.1 RTD temperature probe

Designation	Standard	Measuring range	Measuring accuracy <sup>a</sup>	R <sub>100</sub> / R <sub>0</sub>	ITS
Pt50 2/3-wire circuit 4-wire circuit	GOST 6651-2009 A.2	-200 to +850 °C -200 to +850 °C	±0.5 K ±0.3 K	1.3911	90
Pt100, Pt1000 2/3-wire circuit  4-wire circuit	IEC 60751:2008	-100 to +200 °C -200 to +850 °C -100 to +200 °C -200 to +850 °C	±0.2 K ±0.4 K ±0.15 K ±0.25 K	1.3851	90
Pt500 2/3-wire circuit  4-wire circuit	IEC 60751:2008	-100 to +200 °C -200 to +850 °C -100 to +200 °C -200 to +850 °C	±0.4 K ±0.4 K ±0.1 K ±0.2 K	1.3851	90
Ni100, Ni500, Ni1000 2/3-wire circuit 3-wire circuit	DIN 43760:1987-09	-60 to +250 °C -60 to +250 °C	±0.4 K ±0.2 K	1.618	IPTS-68
Ni100 2/3-wire circuit 3-wire circuit	GOST 6651-2009 A.5	-60 to +180 °C -60 to +180 °C	±0.4 K ±0.2 K	1.6172	90

Designation	Standard	Measuring range	Measuring accuracy <sup>a</sup>	R <sub>100</sub> / R <sub>0</sub>	ITS
Pt100 2/3-wire circuit 4-wire circuit	GOST 6651-2009 A.2	-100 to +200 °C -200 to +850 °C -100 to +200 °C -200 to +850 °C	±0.2 K ±0.4 K ±0.15 K ±0.25 K	1.3911	90
Cu50 2/3-wire circuit 4-wire circuit	GOST 6651-2009 A.3	-180 to +200 °C -180 to +200 °C	±0.5 K ±0.3 K	1.428	90
Cu100 2/3-wire circuit 4-wire circuit	GOST 6651-2009 A.3	-180 to +200 °C -180 to +200 °C	±0.4 K ±0.2 K	1.428	90
Ambient temperature influence		≤ ±0.005 %/K deviation from 22 °C			
Measuring current		< 0.3 mA			
Sensor line resistance		≤ 50 Ω per line for 3- and 4-wire circuit ≤ 100 ohms line resistance for 2-wire circuit			
Lead compensation		Not required for 3-wire or 4-wire circuit. In 2-wire circuits, lead compensation is performed in the software by entering a fixed line resistance.			
Special features		- Can also be programmed in °F - Basic sensor type can be changed with sensor factor (e.g., Pt50 to Pt100)			

a The accuracy specifications refer to the maximum measuring range.

## 9.1.2 Thermocouples

Designation	Standard	Measuring range	Measuring accuracy <sup>b</sup>	ITS
Fe-CuNi "L"	DIN 43710:1985-12	-200 to +900 °C	±0.1 %	68
Fe-CuNi "J"	DIN EN 60584-1:2014	-210 to +1200 °C	±0.1 % from -100 °C	90
Cu-CuNi "U"	DIN 43710:1985-12	-200 to +600 °C	±0.1 % from -100 °C	68
Cu-CuNi "T"	DIN EN 60584-1:2014	-200 to +400 °C	±0.1 % from -150 °C	90
NiCr-Ni "K"	DIN EN 60584-1:2014	-200 to +1300 °C	±0.1 % from -80 °C	90
NiCr-CuNi "E"	DIN EN 60584-1:2014	-200 to +1000 °C	±0.1 % from -80 °C	90
NiCrSi-NiSi "N"	DIN EN 60584-1:2014	-200 to +1300 °C	±0.1 % from -80 °C	90
Pt10Rh-Pt "S"	DIN EN 60584-1:2014	-50 to 1768 °C	±0.15 % from -60 °C	90
Pt13Rh-Pt "R"	DIN EN 60584-1:2014			
Pt30Rh-Pt6Rh "B"	DIN EN 60584-1:2014	-50 to 1820 °C	±0.15 % from 400 °C	90
W5Re-W26Re "C"	DIN EN 60584-1:2014	0 to 2315 °C	±0.15 %	90
W5Re-W20Re "A"	DIN EN 60584-1:2014	0 to 2500 °C	±0.15 %	90
W3Re-W25Re "D"	ASTM E1751M-20	0 to 2315 °C	±0.25 %	90
Chromel®-COPEL® "L"	GOST R 8.585-2001	-200 to +800 °C	±0.1 % from -80 °C	90
Chromel®-Alumel®	GOST R 8.585-2001	-270 to +1372 °C	±0.1 % from -80 °C	90
PLII (Platinel II)	ASTM E1751M-20	0 to 1395 °C	±0.15 %	90

Designation	Standard	Measuring range	Measuring accuracy <sup>b</sup>	ITS
Ambient temperature influence		≤ ±0.005 %/K deviation from 22 °C, additionally the cold junction accuracy		
Measuring range start/end		Freely programmable within the limits in steps of 0.1 °C		
Cold junction		Pt1000 internal, thermostat (fixed constant value), adjustable		
Reference point accuracy (internal)		±1 K		
Reference point temperature (fixed constant value)		-20 to +80 °C adjustable		
Special features		Can also be programmed in °F		

b The accuracy specifications refer to the maximum measuring range.

### 9.1.3 Standard signals

Designation	Measuring range	Measuring accuracy <sup>c</sup>	Ambient temperature influence
<b>Voltage</b> freely scalable Input resistance $R_E > 500 \text{ k}\Omega$ Input resistance $R_E > 1 \text{ M}\Omega$	DC 0 to 10 V DC 0 to 1 V 0 to 100 mV	±5 mV ±0.05 %	≤ ±0.005 %/K Deviation of 22 °C
<b>Current</b> (voltage drop ≤ 2 V), freely scalable	DC 0(4) to 20 mA	±20 µA	≤ ±0.005 %/K Deviation of 22 °C
Galvanic isolation	see Chapter 3.5 "Galvanische Trennung"		
Special features	Measuring range scaling, adjustable		

Designation	Measuring range	Measuring accuracy <sup>c</sup>	Ambient temperature influence
Limits in accordance with NAMUR recommendation NE 43 in case of deviation above/below measured range			<b>Signal type 4 to 20 mA</b>
Measurement information M			3.8 to 20.5 mA
Failure information A for deviation below measured value/short-circuit ("NAMUR Low")			≤ 3.6 mA
Failure information A for deviation above measured value/probe break ("NAMUR High")			≥ 21 mA

c The accuracy specifications refer to the maximum measuring range.

#### 9.1.4 Resistance transmitter

Designation	Measuring range	Measuring accuracy <sup>d</sup>	Ambient temperature influence
Resistance transmitter	max. 10 k $\Omega$	±10 $\Omega$	≤ ±0.01 % per K Deviation of 22 °C
Connection type	Resistance transmitter: 3-wire circuit		
Sensor line resistance	max. 50 $\Omega$ per line		
Resistance values	Freely programmable within the limits in steps of 0.1 $\Omega$		
Special features	Measuring range scaling, adjustable		

d The accuracy specifications refer to the maximum measuring range.

## 9.1.5 Resistance/potentiometer

Designation	Measuring range	Measuring accuracy	Ambient temperature influence
Sensor type resistance/potentiometer	max. 10 k $\Omega$	$\pm 10 \Omega$	$\leq \pm 0.01 \text{ %/K}$ Deviation of 22 °C
Connection type	Potentiometer with 2-, 3- or 4-wire circuit		
Sensor line resistance	$\leq 50 \Omega$ per line for 3- and 4-wire circuit $\leq 100 \Omega$ line resistance for 2-wire circuit		
Resistance values	Freely programmable within the limits in steps of 0.1 $\Omega$		
Special features	Measuring range scaling, adjustable		

## 9.2 Measuring circuit monitoring

Measuring probe	Out of range	Probe/cable break	Probe/cable short circuit
RTD temperature probe	is detected	is detected	is detected
Resistance transmitter	is detected	is detected	is not detected
Thermocouple (single)	is detected	is detected	is not detected
Double thermocouple	is detected	is detected	is detected
Voltage 0 to 10 V 0 to 1 V	is detected is detected	is not detected is not detected	is not detected is not detected

Measuring probe	Out of range	Probe/cable break	Probe/cable short circuit
Current 4 to 20 mA 0 to 20 mA	is detected is detected	is detected is not detected	is detected is not detected

### 9.3 Test voltages

Input and output against voltage supply	
- With voltage supply AC 110 to 240 V +10%, -15%	4260 V
- With voltage supply DC 24 V	4260 V

### 9.4 Electrical safety

	Clearances / creepage distances
Mains voltage to electronic components and probes	$\geq 8 \text{ mm} / \geq 4 \text{ mm}$
Mains voltage to relays	$\geq 8 \text{ mm} / \geq 4 \text{ mm}$
Relays to electronic components and probes	$\geq 8 \text{ mm} / \geq 4 \text{ mm}$

### 9.5 Analog output

Resolution D/A converter >15 bit	Load resistance $R_{load}$	Accuracy	Burden influence
Voltage DC 0(2) to 10 V	$\geq 500 \Omega$	$\leq \pm 0.05\%$ referring to 10 V	$\leq \pm 15 \text{ mV}$
Current DC 0(4) to 20 mA	$\leq 500 \Omega$	$\leq \pm 0.05\%$ referring to 20 mA	$\leq \pm 0.02 \text{ \%/}100 \Omega$

## 9.6 Relay output (extra code 018)

Designation	Function
Limit value relay output	Relay (changeover contact) Contact protection circuit: Fuse cut-out 3.15 AT installed in pin branch 30,000 switching operations at a switching capacity of AC 240 V, 3 A, 50 Hz (resistive load) or maximum DC 30 V, 3 A. Minimum current: DC 12 V, 100 mA

## 9.7 Display

Type, resolution	Dot-matrix LCD display with 64 × 96 pixels
Brightness setting	Contrast can be adjusted on device, background lighting can be switched off via timeout

## 9.8 Electrical data

Voltage supply	DC 24 V, +10, -15 % or AC 110 to 240 V +10, -15 %, 48 to 63 Hz
Power consumption	With voltage supply 240 V: max. 3 W, 10 VA With voltage supply 24 V: max. 3 W
Inputs and outputs Conductor cross section	Max. 2.5 mm <sup>2</sup> , wire or strand with ferrule
Electrical safety	According to DIN EN 60730-1:2021 und DIN EN 61010-1:2020 Overvoltage category III, pollution degree 2 Test peak voltage, measurement input to analog output: 1875 V / 50 Hz
Electromagnetic compatibility <sup>a</sup> Interference emission Interference immunity	According to DIN EN 60730-1:2021 und DIN EN 61326-1:2022 Class A - For industrial applications only - Industrial requirements
Sampling rate	2/s
Input filter	Digital filter, 2nd order; filter time constant can be adjusted from 0 to 100 s

a. The deviation under EMC load is 1% in relation to the measuring range.

## 9.9 Environmental influences

Operating/storage temperature range	-10 to +70 °C / -20 to +80 °C
Resistance to climatic conditions	≤ 85% relative humidity, annual average, no condensation

## 9.10 Housing

Site altitude	maximum 2000 m above MSL
Case type, material	Plastic housing, polycarbonate (use in interiors only)

Electrical connection	Pluggable screw terminals
Mounting on	Mounting rail 35 mm x 7.5 mm according to DIN IEC 60715
Close mounting	Permitted
Installation position	Vertical
Protection type	IP20 according to DIN EN 60529
Weight with screw terminals	Approx. 200 g

## 9.11 Approvals/approval marks

Approval mark	Test facility	Certificate/certification number	Inspection basis	Valid for
SIL2, SIL3	TÜV Nord (German Technical Inspection Agency)	SEBS-A.093409/14 V1.0	DIN EN 61508 1-7	Only for devices with extra code 058
PL c / PL d	TÜV Nord (German Technical Inspection Agency)	SEBS-A.093409/14 V1.0	DIN EN ISO 13849	
c UL us	Underwriters Laboratories	2018-10-8-E201387	UL 61010-1	All versions
DNV	DNV	TAA00002C4	DNVGL-CG-0339	Only for devices with extra code 062

## 10 Setup program





The program and the connecting cable are available as accessories and offer the following possibilities:

- Easy and comfortable parameterization and archiving via PC
- Easy parameter duplication for identical types of devices

### 10.1 Minimum hardware and software requirements:

- PC Pentium III or higher
  - 200 MB free hard disk space
  - CD-ROM drive
  - Free USB interface, mouse connection
  - Microsoft<sup>1</sup> Windows7 (32-bit) -> 1GB RAM
  - Microsoft<sup>1</sup> Windows7 (64-bit) -> 2GB RAM
- \* Connect the device to the PC using the USB cable

### 10.2 Displaying the device software version

- \* Press the  key
- \* Use  to switch to device info and press 
- \* Press  and the software version appears.

The software versions for the device and the setup program must be compatible. Only the last two digits may be different, otherwise an error message appears!

The version of the setup prog. appears under *Info* ⇒ *Info about setup*.

1. Microsoft is a registered trademark of Microsoft Corporation

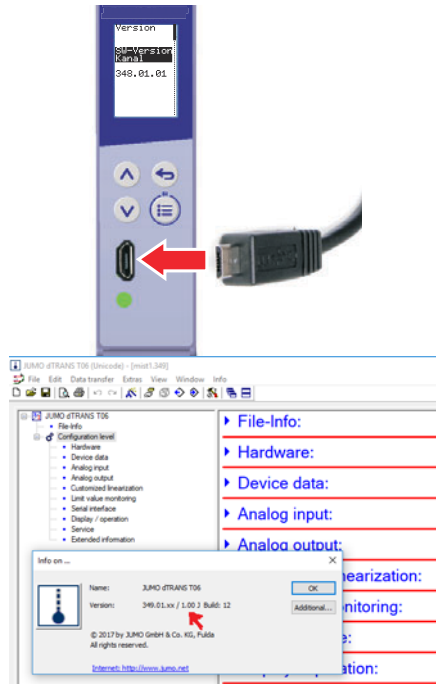

## 10.3 Forgotten the code?

If you forget the code, it can be read out via the USB interface and the setup program.

\* Use *Data transfer*  $\Rightarrow$  *from device*.

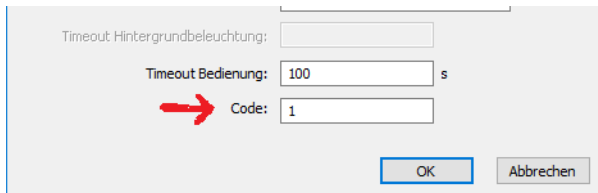

The screenshot shows a dialog box with the following fields and buttons:

- Timeout Hintergrundbeleuchtung:
- Timeout Bedienung:  s
- Code:  (A red arrow points to this field)
- Buttons: OK, Abbrechen

The read-out code now appears in the setup program in the sub-menu "Display/operation".

It can be kept as it is or changed.

If "0" is set and transferred to the device, the code interrogation is deactivated and the configuration level is freely accessible.

## 10.4 Customer-specific linearization

Coefficients (DKD calibration values), formulas, or 40 value pairs (grid points) can be entered in the customer linearization sub-menu.

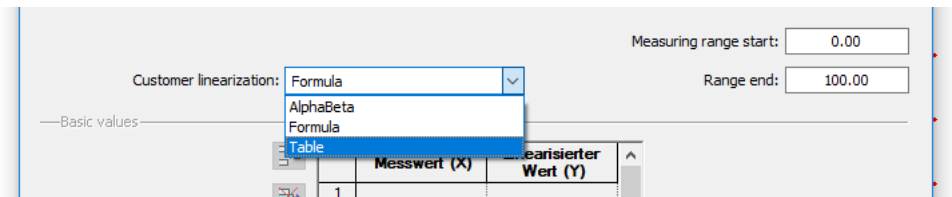

The screenshot shows the "Customer linearization" sub-menu with the following elements:

- Measuring range start:
- Range end:
- Customer linearization:  (Dropdown menu is open showing options: Formula, AlphaBeta, Formula, Table)
- Basic values: 

Messwert (X)	Linearisierter Wert (Y)
1	

## 10.5 Reset drag indicator

The drag indicator shows the maximum and minimum measured value. It can be reset with the setup program. The measured value currently shown in the display is set.

On the device, see Chapter 7.8.3 "Min.value reset"

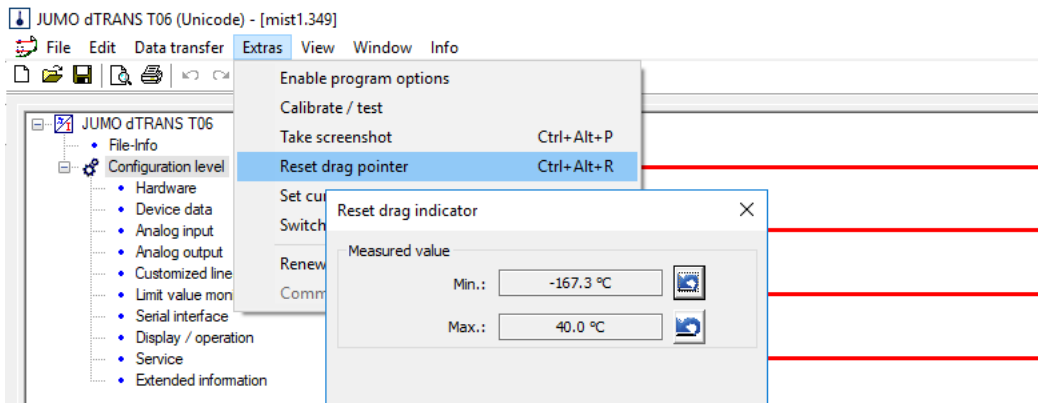

## 10.6 Switch on / switch off SIL extra code

The restrictions for SIL operation can only be deactivated with the setup program.

The screenshot shows the JUMO dTRANS T06 software interface. The 'Extras' menu is open, highlighting the 'Switch to SIL-operation' option (Ctrl+Alt+S). Below the menu, two dialog boxes titled 'Switch to SIL operation' are displayed. The top dialog shows 'SIL operation: Switched on' and a 'Switch off' button with a red arrow pointing to it. The bottom dialog shows 'SIL operation: OFF' and a 'Switch on' button with a red arrow pointing to it. Both dialog boxes have a 'Close' button.

## 10.7 Checking of safety relevant system settings





### Caution

To make sure that all parameters after setup are transmitted correctly, the user has to validate the parameters, the safety function (error signal) and has to check the control action of the limit values.

## 11 Error messages

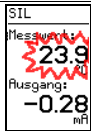
### 11.1 Display types

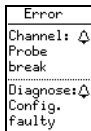
	<p>Measured value flash-</p>	<p>The measured value flashes.</p> <p>The analog output has dropped and displays the negative limit.</p> <p>* Press the  key for further information.</p>
		<p>Here, the diagnostics channel has detected an error at the analog output, as can also be seen in the table Chapter 11.3 "Diagnostics channel".</p>

## 11.2 Safety channel

Display	Origin	Cause/remedy
Terminal temperature	Internal	Terminal temperature outside the limits or probe faulty
Reference AD converter	Internal	Deviation during the reference measurement of the AD converter/ Restart device / return device
Not calibrated	Internal	Channel not calibrated
Configuration	Internal	Configuration data outside the value range. * Acknowledgement is not possible until it is within the admissible range again.
CRC Test Calibr.	Internal	Checksum error of the EEPROM calibration data. Restart device / return device.
CRC Test Config.	Internal	Checksum error of the EEPROM configuration data. Restart device / return device.
CPU Register	Internal	A CPU registry error has occurred. Restart device / return device
RAM defective	Internal	A RAM error has occurred. Restart device / return device.
ROM defective	Internal	A ROM error has occurred. Restart device / return device.
Program sequence	Internal	A program sequence error has occurred. Restart device / return device.
Watchdog	Internal	A watchdog reset has occurred. Restart device / return device.

Display	Origin	Cause/remedy
Voltage supply	Internal	The voltage supply is insufficient. Check voltage supply.
Frequency deviation	Internal	Error of the independent time base. Restart device / return device.
EEPROM defective	Internal	Error during internal communication with the EEPROM. Restart device / return device.
Stack	Internal	Error in the memory area reserved for the stack. Restart device / return device.
AD converter	Internal	A program sequence error has occurred. Restart device / return device.
Interrupt	Internal	Interrupt error Restart device / return device.
Limit value	System	The configured limit value has been exceeded or fallen short of. Check system / adapt limit value

## 11.3 Diagnostics channel

Display	Origin	Cause/remedy
Voltage 3 V	Internal device	Error detected when measuring the 3 V voltage supply Restart device / return device.
Voltage 5 V	Internal device	Error detected when measuring the 5 V voltage supply Restart device / return device.
Signal analog output	Internal device	<p>Analog output signal deviates from the specification of the safety channel. This may be caused by an "open" analog output (without load) in SIL operation.</p> <p><b>Note:</b> Error is only reported if the deviation occurs for more than 5 seconds.</p> <p><b>Remedy:</b></p> <ul style="list-style-type: none"> <li>* Check load at analog output</li> <li>* In the configuration level -&gt; Service -&gt; Reset error -&gt; yes</li> </ul> <p>If this error is rectified, the analog output once again delivers valid values.</p> <div style="border: 1px solid black; padding: 5px; display: inline-block;"> <p>Service      SIL r0</p> <p>RBI error    Measur.:    34.6 °C</p> <p>an. output    ↑</p> <p>Yes</p> <p>Output:      7.34 mA</p> </div> <p>A restart also results in a reset of the error.</p>
Relay status	Internal device	Relay setting deviates from the specification of the safety channel. Restart device / return device.
Voltage analog output	Internal device	Error detected when measuring the analog output voltage supply. Restart device / return device.



Display	Origin	Cause/remedy
Software versions	Internal device	The software versions of the safety channel and diagnostics channel do not match. Restart device / return device.
Internal comm.	Internal device	Communication between safety channel and diagnostics channel faulty. Restart device / return device.
Editing procedure	Internal device	An error has occurred during editing. Restart device / return device.
Relay switch cycle	Internal device	The configured limit of the switching cycles has been exceeded. The error can be remedied by reducing the current counter or increasing the limit. ⇒ Chapter 7.8.5 "Grenze Schaltspiele"
Config. faulty	Internal device	The configuration is faulty <b>* Check configuration</b>
ROM defective	Internal diagnostics	A ROM error has occurred. Restart device / return device.
RAM defective	Internal diagnostics	A RAM error has occurred. Restart device / return device.
Parameter faulty	Internal diagnostics	Parameter faulty <b>* Check configuration</b>
CRC Test RAM	Internal diagnostics	CRC test of configuration in RAM returned an error Restart device / return device.
CRC Test EEPROM	Internal diagnostics	CRC test of configuration in EEPROM returned an error Restart device / return device.
Program sequence	Internal diagnostics	Program sequence faulty. Restart device / return device.

Display	Origin	Cause/remedy
EEPROM access	Internal diagnostics	An error occurred during EEPROM reading/writing. Restart device / return device.
USB communication	Internal diagnostics	Error during communication via USB. Restart device / return device.
RS485 communication	Internal diagnostics	Error during RS485 communication. Restart device / return device.

## 11.4 Measured value recording

Display	Cause/remedy
<<<<<	Underrange / check sensor configuration, check measuring chain
>>>>>	Overrange / check sensor configuration, check measuring chain
- - - - -	Invalid value / restart device, otherwise return device
- - 4 - -	Division by zero / restart device, otherwise return device
+++++	Error relating to terminal temperature or compensation signal / restart device, otherwise return device
<-<-<	Probe short circuit / check sensor configuration, check line for short circuit
>->->	Probe break / check sensor configuration, check line for short circuit
-1-0-	No data received from channel / restart device, otherwise return device
*****	Value cannot be displayed, overrange / restart device, otherwise return device

## 12 What to do, if ...

Description	Cause	Remedy
<p>The following appears in the display:</p> 	<p><b>Setup program transmits data.</b> The safe state is assumed during data transmission (if SIL is active). The data is then exchanged between channel and diagnostics and then the device returns to normal state.</p>	<ul style="list-style-type: none"><li>- Wait until data transmission has finished.</li></ul>
<p>The following appears in the display:</p> 	<p>Changes were made in the configuration level that are implausible or that have an impact on the downstream function blocks. This can also cause the LED to light up red. <b>Example:</b> If the sensor type is changed from RTD temperature probe to thermocouple, for example, the linearization of the thermocouple must also be entered so that the following functions such as limit value monitoring can function correctly.</p>	<ul style="list-style-type: none"><li>- Check the settings in the configuration level until the LED lights up green again.</li></ul> <p>⇒ Chapter 5.1 "Display and control elements"</p>

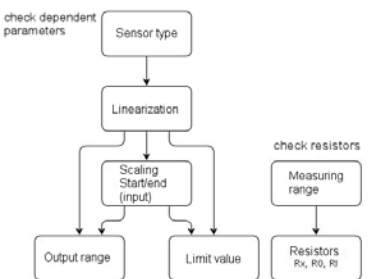
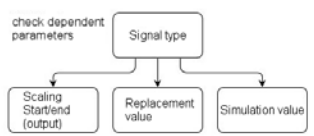
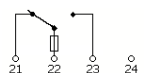
Description	Cause	Remedy
<p>If a parameter in this tree structure is changed, the underlying parameters must be checked for correctness and adjusted if necessary.</p>	<div style="display: flex; justify-content: space-around;"> <div style="text-align: center;"> <h3>Analog input</h3>  <pre> graph TD     A[Sensor type] -- "check dependent parameters" --&gt; B[Linearization]     B --&gt; C[Scaling Start/end (input)]     C --&gt; D[Output range]     C --&gt; E[Limit value]     F[Measuring range] -- "check resistors" --&gt; G[Resistors Rx, R0, Ri]           </pre> </div> <div style="text-align: center;"> <h3>Analog output</h3>  <pre> graph TD     H[Signal type] -- "check dependent parameters" --&gt; I[Scaling Start/end (output)]     H --&gt; J[Replacement value]     H --&gt; K[Simulation value]           </pre> </div> </div>	
<p>... Relay output limit value does not switch as shown in the symbol</p>	<p>- The integrated fuse cut-out is defective, caused by an excessive relay current.</p> 	<ul style="list-style-type: none"> <li>* Check whether the relay option is available.</li> <li>* Measure relay terminal 21 and 22 with a continuity tester in standby mode (without voltage supply).</li> <li>* If continuity cannot be measured, the device must be repaired at JUMO.</li> </ul> <p>⇒ For service addresses see back cover</p>
<p>... The backlight is off.</p>	<p>- Timeout lighting was activated. The backlight switches off automatically after the set time.</p>	<ul style="list-style-type: none"> <li>* Press any key or switch off timeout.</li> </ul> <p>⇒ Chapter 7.3.5 "Time-out lighting"</p>

Description	Cause	Remedy
The LED lights up red	<ul style="list-style-type: none"><li>- Here, all points that indicate a diagnostic error must be checked.</li><li>- Check dependent parameters (described in the table above)</li></ul>	<ul style="list-style-type: none"><li>* Is the current output wired correctly? The current output may not deliver current if the connected device is "too resistive" or if the cables are faulty.</li><li>⇒ Chapter 4.2.2 "Analog output (part of the safety channel)"</li></ul>



**13 Certificates**



More than **100 years** of experience

**JUMO GmbH & Co. KG**  
Moritz-Juchheim-Strasse 1  
36039 Fulda, Germany

Email: [mail@jumo.net](mailto:mail@jumo.net)  
Internet: [www.jumo.net](http://www.jumo.net)

Tel.: +49 681 600330  
Fax: +49 681 60033500

## EU-Konformitätserklärung

EU declaration of conformity / Déclaration UE de conformité

### Dokument-Nr.

Document No. / Document n°:

CE 788

### Hersteller

Manufacturer / Etalabé par

JUMO GmbH & Co. KG

### Anschrift

Address / Adresse

Moritz-Juchheim-Strasse 1, 36039 Fulda, Germany

### Produkt

Product / Produit

Name  
Name / Nom

Typ  
Type / Type

JUMO DTRANS T06

707071

Typenblatt-Nr.  
Data sheet no. / N°  
Document  
d'identification  
707070

**Wir erklären in alleiniger Verantwortung, dass das bezeichnete Produkt die Anforderungen der Europäischen Richtlinien erfüllt.**

*We hereby declare in sole responsibility that the designated product fulfills the requirements of the European Directives.  
Nous déclarons sous notre seule et personnelle responsabilité que le produit rempli les Directives Européennes.*

### Richtlinie 1

Directive / Directive

### Name

Name / Nom

EMC

### Fundstelle

Reference / Référence

2014/30/EU

### Bemerkung

Comment / Remarque

**Datum der Erstanbringung des CE-Zeichens 2018**  
Date of first application of the CE mark to the product / Date  
de l'ee application du sigle sur le produit

Dokument-Nr.  
Document No. / Document n°:

CE 788

EU-Konformitätserklärung

Seite: 1 von 4



More than **100 years** of experience

**JUMO GmbH & Co. KG**  
 Max-Planck-Strasse 1 Tel.: +49 691 610030  
 38039 Völk, Germany Fax: +49 691 61003500 E-Mail: mail@jumo.net  
 Internet: www.jumo.net

#### Angewendete Normen/Spezifikationen

Standards/Specifications applied / Normes/Spécifications appliquées

##### Fundstelle

##### Ausgabe

Reference / Référence

Edition / Edition

##### Bemerkung

Comment / Remarque

EN 60730-1 2011  
 EN 60730-2-9 2010  
 EN 61326-1 2013

#### Gültig für Typ

Valid for Type / Valable pour le type

707071/1,...

#### Richtlinie 2

Directive / Directive

##### Name

LVD

Name / Nom

##### Fundstelle

2014/35/EU

Reference / Référence

##### Bemerkung

Comment / Remarque

**Datum der Erstanbringung des CE-Zeichens 2018**

Date of first application of the CE mark to the product / Date

de 1<sup>ère</sup> application du sigle sur le produit

#### Angewendete Normen/Spezifikationen

Standards/Specifications applied / Normes/Spécifications appliquées

##### Fundstelle

##### Ausgabe

Reference / Référence

Edition / Edition

##### Bemerkung

Comment / Remarque

EN 60730-1 2011  
 EN 60730-2-9 2010  
 EN 61010-1 2010

Dokument-Nr.  
 Document No. / Document n°

CE 788

EU-Konformitätsklärung

Seite: 2 von 4



More than  
sensors & instruments

**JUMO GmbH & Co. KG**  
Maximilianstraße 1  
36039 Fulda, Germany

Tel.: +49 691 6003-0  
Fax: +49 691 6003-500

E-Mail: mail@jumo.net  
Internet: www.jumo.net

### Gültig für Typ

Valid for Type / Valable pour le type  
70707-1/-\* -23...  
70707-1/-\* -018

### Richtlinie 3

Directive / Directive

### Name

ROHS

Name / Nom

### Fundstelle

2011/65/EU

Reference / Référence

### Bemerkung

Comment / Remarque

Datum der Erstarbringung des CE-Zeichens 2018

### auf dem Produkt

Date of first application of the CE mark to the product / Date  
de première application du sigle sur le produit

### Angewendete Normen/Spezifikationen

Standards/Specifications applied / Normes/Spécifications appliquées

### Fundstelle

Ausgabe

Reference / Référence

Edition / Edition

VDK Umweltrelevante Aspekte

V1

bei der Produktentwicklung und  
-gestaltung

Bemerkung

Comment / Remarque

### Gültig für Typ

Valid for Type / Valable pour le type  
70707-1/...

Dokument-Nr.  
Document No. / Document n°

CE 788

EU-Konformitätsklärung

Seite: 3 von 4

**JUMO GmbH & Co. KG**  
Max-Planck-Strasse 1  
36039 Fulda, Germany

Tel: +49 661 6003-0  
Fax: +49 661 6003-500

E-Mail: [mail@jumo.net](mailto:mail@jumo.net)  
Internet: [www.jumo.net](http://www.jumo.net)



More than **100 years** of experience

JUMO GmbH & Co. KG

Fulda, 2018-04-20

**Aussteller**  
Issued by / *Etsaill par*  
**Ort, Datum**  
Place, date / *Lieu, date*

**Rechtswidrliche Unterschriften**

Legally binding signatures /  
*Signatures juridiquement valable*

Bereichsleiter Vertrieb Inland / *Globales*  
Produkt- und Branchenmanagement  
ppa. Dimitrios Charaladis

Qualitätsbeauftragter und Leiter Qualitätswesen  
i. V. Harald Gienger

Dokumenten-  
Document No. / Document n°

CE 788

EU-Konformitätserklärung

Seite 4 von 4



# Certificate

SEBS-A-093409/14, VZ.0

TÜV NORD Systems GmbH & Co. KG hereby certifies to

**JUMO GmbH & Co. KG**

Moritz-Juchheim-Strabe 1  
36039 Fulda

that the safety related temperature transmitter

**JUMO dTRANS T06**

**(Type 707071, order detail 058)**

meets the requirements listed in the below mentioned standards.

- DIN EN 61508-1/-2/-3: 2011; SIL 2 (HFT = 0) and SIL 3 (HFT ≥ 1)
- DIN EN ISO 13849-1: 2023; PL c (Cat. 2, HFT = 0) and PL d (Cat. 3, HFT = 1)
- DIN EN ISO 13849-2: 2013
- DIN EN IEC 60730-2-9: 2021

Certification program Leittechnik (SEBS-ZE:SEECERTVA-320-20, Rev. 6/04/24)

The certification is based on the report No. SEBS-A-093409/14TB in the respective valid version.

This certificate entitles the usage of the adjacent conformity mark.

Valid until: 2029-09-13

File reference: 8122513440

Hamburg, 2024-09-13

Digitally signed by  
**TÜV NORD**  
Name: Tobias Nölke  
Date: 2024.09.13  
12:27:30 +0200

**Tobias Nölke**  
(Head of certification body)



Certification Body SEECERT  
TÜV NORD Systems GmbH & Co. KG  
Große Bahnstraße 31, 22525 Hamburg, Germany



## TYPE APPROVAL CERTIFICATE

Certificate No:  
**TA00002C4**  
 Revision No:  
**2**

This is to certify:

That the Measurement Converter

with type designation(s)  
**JUMO dTRANS T06 (Type 707071)**

Issued to

**JUMO GmbH & Co. KG**  
**Fulda, Hessen, Germany**

is found to comply with

**DNV rules for classification – Ships, offshore units, and high speed and light craft**

Application :

**Product(s) approved by this certificate is/are accepted for installation on all vessels classed by DNV.**

Temperature	<b>B</b>
Humidity	<b>B</b>
Vibration	<b>A</b>
EMC	<b>A/B*</b> (see page 2)
Enclosure	<b>A</b>

Issued at **Hamburg** on **2024-05-17**

This Certificate is valid until **2029-05-21**.

DNV local station: **Essen**

Approval Engineer: **Holger Jansen**



for DNV  
 Digitally Signed By: Papanuskas, Joannis  
 Location: DNV DE Hamburg, Germany

**Joannis Papanuskas**  
 Head of Section

This Certificate is subject to terms and conditions overview. Any significant change in design or construction may render this Certificate invalid.

The validity date relates to the Type Approval Certificate and not to the approval of equipment/systems related.

**LEGAL DISCLAIMER:** Unless otherwise stated in the applicable contract with the holder of this document, or following from mandatory law, the liability of DNV AS, its parent companies and their subsidiaries as well as their officers, directors and employees ("DNV") arising from or in connection with the services rendered for the purpose of the issuance of this document or reliance thereon, whether in contract or in tort (including negligence), shall be limited to direct losses and under any circumstances be limited to 300,000 USD.

Form code: TA\_251

Revision: 2021-03

www.dnv.com

Page 1 of 3



**Product description**

Multifunctional Four-Wire Transmitter for DIN-rail mounting with galvanic isolation and configurable linearization.

**Analog Input**

- RTD Temperature probe in 2-, 3- or 4-wire connection
- Thermocouple, double thermocouple
- Resistance transmitter
- Resistance/potentiometer in 2-, 3- or 4-wire connection
- Voltage 0 to 1 V, 0 to 10 V
- Current 0(4) to 20 mA

**USB-Interface**

- USB (Device) for Setup

**Analog output**

- 0(4) to 20 mA, 0(2) to 10 V

**Dot-matrix-LCD-Display**

- 64 x 96 Pixels with background lighting

**Membrane keyboard**

- 4 Keys for operation

**Relay output limit value**

- Changeover contact

**RS485-Interface**

- Modbus slave

**Order Code 707071-a-bb-ccc****Version:**

- a = 8: Standard version with default settings
- a = 9: Customer specific configuration

**Power supply:**

- Bb = 23: AC 110 to 240 V, +10/-15 %, 48 to 63 Hz (EMC location class A)
- Bb = 29: DC 24 V, +10/-15 % (EMC location class B)

**Extra codes:**

- ccc = 000: None
- ccc = 018: RS485 interface Modbus RTU and limit value relay output
- ccc = 058: SIL and PL approval (yellow front foil)
- ccc = 062: DNV GL approval

**Approval conditions**

The Type Approval covers hardware listed under Product description. When the hardware is used in applications to be classed by DNV, documentation for the actual application is to be submitted for approval by the manufacturer of the application system in each case. Reference is made to DNV rules for classification of ships Pt 4 Ch 9, Control- and Monitoring Systems.

**Product certificate**

If specified in the Rules, ref. Pt 4 Ch 9 Sec. 1, the control and monitoring system in which the above listed hardware is used shall be delivered with a product certificate. For each such delivery the certification test is to be performed at the manufacturer of the application system before the system is shipped to the yard. The test shall be done according to an approved test program.

**Type Approval documentation**

Test reports: Overview test records for DNV GL approval of dTRANS T06 (707071), version 04, dated 2024-04-08.

Overview diagrams and drawings for DNV GL approval of TRANS T06 (707071), version 04, dated 2024-04-08  
Product data sheet 707071007102001K000, V5 00/EN/00727700/2019-08-19.

Operating instructions 707071007102001K000, V5 00/EN/0006903622020-06-30.

JIMO dTRANS T06 device drawing 70707100A002000 K000, vers 02, dated 2021-11-01.

Type approval assessment report, DNV dated 2024-04-03.



Job Id: 262.1-028597-3  
Certificate No: TAA00002CA  
Revision No: 2

### Tests carried out

Applicable tests according to class guideline DNV-CG-0339, August 2021.

### Marking of product

Maker, type designation, serial number.

### Periodical assessment

The scope of the periodical assessment is to verify that the conditions stipulated for the type are complied with, and that no alterations are made to the product design or choice of systems, software versions, components and/or materials.

The main elements of the assessment are:

- Ensure that type approved documentation is available
  - Inspection of factory samples, selected at random from the production line (where practicable)
  - Review of production and inspection routines, including test records from product sample tests and control routines
  - Ensuring that systems, software versions, components and/or materials used comply with type approved documents and/or referenced system, software, component and material specifications
  - Review of possible changes in design of systems, software versions, components, materials and/or performance, and make sure that such changes do not affect the type approval given
  - Ensuring traceability between manufacturer's product type marking and the type approval certificate
- Periodical assessment is to be performed after 2 years and after 3.5 years. A renewal assessment will be performed at renewal of the certificate.

END OF CERTIFICATE

## 13.4 China RoHS

						
产品组别 Productgroup: 707070, 707071, 707075		产品中有害物质的名称及含量 China EEP Hazardous Substances Information				
部件名称 Component Name						
	铅 ( Pb )	汞 ( Hg )	镉 ( Cd )	六价铬 ( Cr(VI) )	多溴联苯 ( PBB )	多溴二苯醚 ( PBDE )
外壳 Housing (Gehäuse)	○	○	○	○	○	○
过程连接 Process connection (Prozessanschluss)	○	○	○	○	○	○
螺母 Nuts (Mutter)	○	○	○	○	○	○
螺栓 Screw (Schraube)	○	○	○	○	○	○
<p>本表格依据SJ/T 11364的规定编制。          This table is prepared in accordance with the provisions SJ/T 11364.          ○ : 表示该有害物质在该部件所有均质材料中的含量均在GB/T 26572规定的限量要求以下。          Indicate the hazardous substances in all homogeneous materials' for the part is below the limit of the GB/T 26572.</p> <p>× : 表示该有害物质至少在该部件的某一均质材料中的含量超出GB/T 26572规定的限量要求。          Indicate the hazardous substances in at least one homogeneous materials' of the part is exceeded the limit of the GB/T 26572.</p>						







#### **JUMO GmbH & Co. KG**

Street address:  
Moritz-Juchheim-Straße 1  
36039 Fulda, Germany  
Delivery address:  
Mackenrodtstraße 14  
36039 Fulda, Germany  
Postal address:  
36035 Fulda, Germany  
Phone: +49 661 6003-0  
Fax: +49 661 6003-607  
Email: [mail@jumo.net](mailto:mail@jumo.net)  
Internet: [www.jumo.net](http://www.jumo.net)

#### **JUMO UK LTD**

JUMO House  
Temple Bank, Riveney  
Hartlow, Essex, CM20 2DY, UK  
Phone: +44 1279 63 55 33  
Fax: +44 1279 62 50 29  
Email: [sales@jumo.co.uk](mailto:sales@jumo.co.uk)  
Internet: [www.jumo.co.uk](http://www.jumo.co.uk)

#### **JUMO Process Control, Inc.**

6724 Joy Road  
East Syracuse, NY 13057, USA  
Phone: +1 315 437 5866  
Fax: +1 315 437 5860  
Email: [info.us@jumo.net](mailto:info.us@jumo.net)  
Internet: [www.jumousa.com](http://www.jumousa.com)

