

JUMO DICON touch

Two/Four-Channel Process and Program Controller
with Paperless Recorder and 8.9 cm (3.5") Touch-
screen

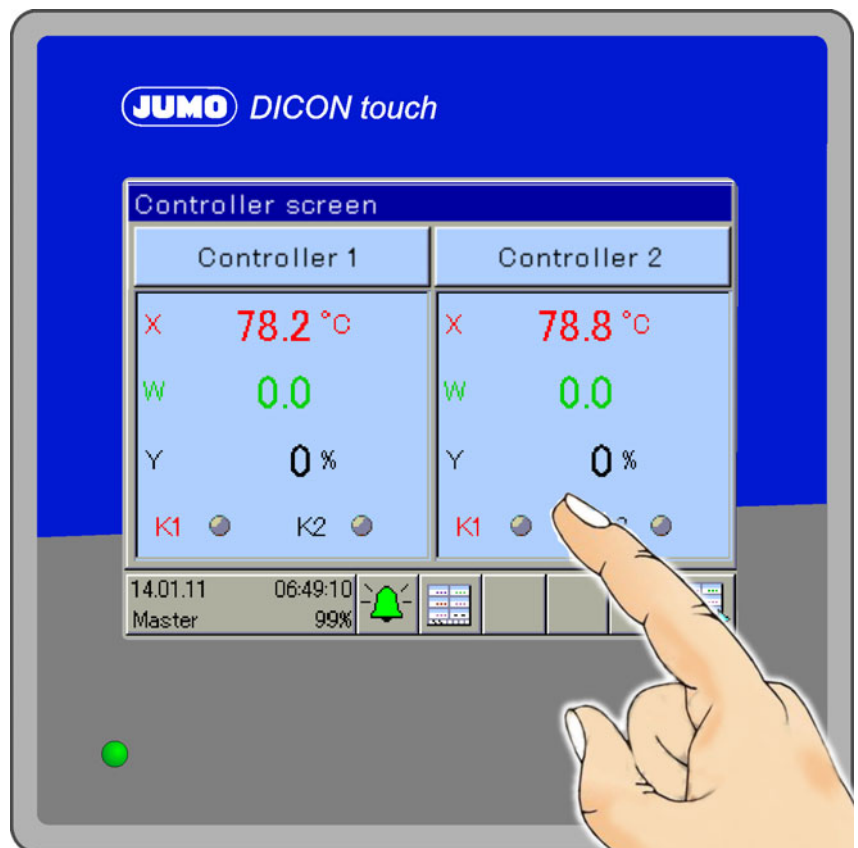

Operating Manual

70357100T90Z004K000



V2.00/EN/00603327/2020-03-10

Table of contents

1	Introduction	9
1.1	Safety information	9
1.1.1	Warning symbols	9
1.1.2	Note signs	9
1.1.3	Display types	10
1.2	Description	11
1.3	Block diagram	12
2	Identifying the device version	13
2.1	Order details	13
2.2	Scope of delivery	15
2.3	General accessories	15
2.4	Accessories	16
2.5	Nameplate	17
3	Mounting	19
3.1	Mounting site and climatic conditions	19
3.1.1	Electrical data	19
3.1.2	Environmental influences	19
3.1.3	Housing	19
3.2	Dimensions	20
3.3	Close mounting	21
3.4	Installation in panel cut-out	21
3.5	Care and treatment of the front cover	21
4	Electrical connection	23
4.1	Installation notes	23
4.1.1	Lines, shielding, and grounding	23
4.1.2	Electrical safety	23
4.1.3	Intended use, misuse	24
4.2	Galvanic isolation	25
4.3	Connection diagram	26
4.3.1	Connection elements	26
4.3.2	Analog inputs	27
4.3.3	Probes for air	28
4.3.4	Probes for water and oil	29
4.3.5	Probes for water, oil, and air	29
4.3.6	Analog outputs	30
4.3.7	Digital inputs	30
4.3.8	Digital outputs	30
4.3.9	Digital outputs	32
4.3.10	Voltage supply (according to nameplate)	32
4.3.11	Interfaces	34

Table of contents

5	Operation	37
5.1	Display and operating concept	37
5.2	Device menu	38
5.3	Alarm and event list	38
5.4	Function buttons, history, and channel changeover	38
5.5	Screens in the operating loop	39
5.5.1	Controller screen 1 to 4 and controller overview screens 1, 2	39
5.5.2	Program controller	41
5.5.3	General screens 1, 2	42
5.5.4	Recording view 1, 2	43
5.5.5	Process screen 1 to 4	43
6	Login	45
6.1	Login	46
6.2	Logout	46
6.3	Changing the password	46
7	User level (Log-In)	47
7.1	Example 4 Transferring controller setpoint values to the user level	47
8	Program administration	49
8.1	Entering program profiles	49
8.1.1	On the device	49
8.1.2	About the setup program	50
8.1.3	Section run time	51
8.1.4	Setpoint value 1 to 4	51
8.1.5	Operating contacts	51
8.1.6	Tolerance band	51
8.1.7	Number of repetitions	52
8.1.8	Start section	52
8.1.9	Parameter block	52
9	Device info	53
9.1	General information	53
9.1.1	Version, motherboard, Ethernet information	53
9.2	Slots	53
9.3	Inputs/outputs	54
9.3.1	Digital and analog inputs, digital and analog outputs, external digital, and external analog inputs	54
9.4	Functions	55
9.4.1	Math, logic signal, limit value outputs	55
9.4.2	Timer signal, digital control signals, operating contacts, controller, analog flag, digital flag	55

Table of contents

9.5	Ethernet	56
9.6	PROFINET	56
10	Functional level	57
10.1	General information	57
10.1.1	Activating the functional level	57
11	Parameterization	59
11.1	Date and time	59
11.2	Daylight saving time	59
11.3	Controller/parameter blocks	60
11.4	Setpoint values	64
11.4.1	Entering the values on the device	64
11.4.2	Entering the values using the setup program	65
12	Configuration	67
12.1	Analog selector	67
12.2	Digital selector	68
12.3	Basic settings	72
12.4	Digital inputs IN1 to 7	74
12.5	Analog inputs IN8, IN9, IN10, IN11	75
12.5.1	Alarms	78
12.6	Controller 1 to 4	79
12.6.1	Controller configuration	79
12.6.2	Controller inputs	82
12.6.3	Controller self-optimization	84
12.6.4	Starting autotuning (SO) on the device	89
12.6.5	Control loop monitoring	91
12.6.6	Output level monitoring	94
12.6.7	Controller setpoint values	97
12.6.8	Ramp function	99
12.7	Digital outputs	101
12.7.1	Switching digital outputs to logic level 1 as a fixed setting	102
12.7.2	Switching digital outputs to manual mode	102
12.8	Analog outputs	103
12.9	Limit value monitoring function	106
12.9.1	Function and hysteresis	108
12.9.2	Hysteresis	109
12.9.3	Startup alarm suppression	110
12.9.4	Acknowledging the lock	110
12.9.5	Alarm	111
12.10	Screen	112
12.10.1	General configuration	112
12.10.2	Configuration screen	113

Table of contents

12.10.3	Start screen and watermark	113
12.10.4	Operation loop	114
12.10.5	Colors recording	115
12.10.6	Colors, designations in controller screen 1 to 4	116
12.10.7	Program controller screen	117
12.10.8	General screens 1, 2	118
12.10.9	Controller overview screen 1, 2	119
12.11	Recording 1, 2	120
12.11.1	Parameters	120
12.11.2	Analog channels	122
12.11.3	Digital channels	122
12.12	Program controller	123
12.12.1	Control signals	126
12.12.2	Extended functions	127
12.12.3	Basic status	128
12.12.4	Operation mode Manual	129
12.12.5	Response by out of range (O-o-R)	130
12.12.6	Weekly program	131
12.13	Timer or week-time switch	132
12.14	Digital controller signals	135
12.14.1	Alarms	137
12.15	Math/logic	138
12.16	Flags/service	140
12.16.1	Flags	140
12.16.2	Service	141
12.17	External digital inputs	142
12.18	External analog inputs	143
12.18.1	Alarms	144
12.19	Serial interfaces	145
12.20	Ethernet	146
12.21	Modbus/TCP	147
12.22	Relay module (accessories)	148
12.23	PROFIBUS DP (option)	149
13	Configuration – in setup program only	151
13.1	Installing the setup program	151
13.1.1	Hardware	151
13.1.2	Software requirements	151
13.2	Starting the setup program	151
13.2.1	Establishing the connection to the device	152
13.2.2	Setup data transfer to or from the external mass storage device	153
13.3	Connection diagram	154
13.4	Country settings	155
13.5	User list	155
13.6	User level	156

Table of contents

13.7	Email	156
13.8	Web server	156
13.9	Modbus frames for reading	157
13.10	Modbus frames for writing	158
13.11	PROFINET-RT	159
13.12	Customer-specific linearization	160
13.12.1	Grid points	160
13.12.2	Formula	161
13.13	Process screens 1 to 4	163
13.13.1	Process screen editor	164
13.13.2	Background	165
13.13.3	Signal types for process screens (overview)	167
13.13.4	General object features	168
13.13.5	Preview screen	169
13.13.6	Transferring the process screen to the device	170
14	Special functions	171
14.1	Calibrating the touchscreen	171
15	Online parameters	173
15.1	Fine adjustment	173
15.2	Ethernet (option)	175
15.3	Date and time	176
15.4	Screenshot	176
15.5	Deleting the measurement-data memory	176
15.6	Approval of extra codes	177
15.7	Testing calibration	178
15.8	Different process values	178
15.9	Startup program	179
16	Error and alarm messages	181
16.1	Error messages in float values and on the display	181
16.2	Display of error messages for binary values	181
17	Retrofitting optional boards	183
17.1	Safety information	183
17.2	Identifying the modules	183
17.3	Installing modules	184
17.3.1	Accessories	186
18	Approvals/approval marks	187
18.1	GL	187

Table of contents

18.2	DIN	193
19	China RoHS	195

1.1 Safety information

General information

This manual contains information that must be observed in the interest of your own safety and to avoid damage to assets. This information is supported by symbols which are used in this manual as indicated.

Please read this manual before commissioning the device. Keep the manual in a place accessible to all users at all times.

If difficulties occur during commissioning please refrain from carrying out any manipulations that could jeopardize your warranty rights.

1.1.1 Warning symbols



DANGER!

This symbol indicates that **personal injury caused by electrical shock** may occur if the respective precautionary measures are not carried out.



WARNING!

This symbol in connection with the signal word indicates that personal injury may occur if the respective precautionary measures are not carried out.



CAUTION!

This symbol in connection with the signal word indicates that **damage to assets or data loss** will occur if the respective precautionary measures are not taken.



CAUTION!

This symbol indicates that **components could be destroyed** by electrostatic discharge (ESD = Electro Static Discharge) if the respective cautionary measures are not taken. Only use the ESD packages intended for this purpose to return device inserts, assembly groups, or assembly components.



READ DOCUMENTATION!

This symbol – placed on the device – indicates that the associated **device documentation has to be observed**. This is necessary to recognize the kind of the potential hazards as well as the measures to avoid them.

1.1.2 Note signs



NOTE!

This symbol refers to **important information** about the product, its handling, or additional use.



REFERENCE!

This symbol refers to **further information** in other sections, chapters, or manuals.

1 Introduction



FURTHER INFORMATION!

This symbol is used in the tables and refers to **further information** in connection with the table.



DISPOSAL!

This device and the batteries (if installed) must not be disposed in the garbage can after use! Please ensure that they are disposed properly and in an **environmentally friendly manner**.

1.1.3 Display types

Menu structure

The > symbol between words indicates a menu structure and enables the parameters to be quickly detected in the configuration level or for navigation in the setup program, such as the software version of the devices, for example:

DEVICE MENU > GENERAL > VERSION > SW VERSION

Active input

The device has no keys and is operated using a finger or a pen.

The following manual will therefore make references to **"touching"** and the images displayed will show a hand operating the device.

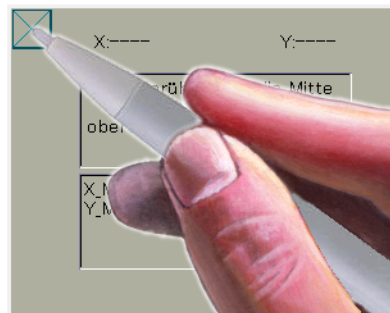
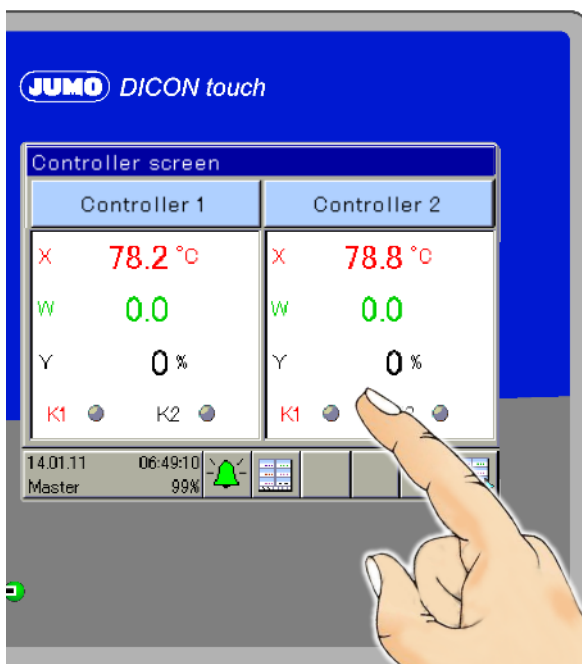

1.2 Description

The DICON touch is a universal process and program controller with 4 control channels, which displays information on a vibrant display and is operated intuitively with touchscreen.

Up to 4 control channels are available via the tried-and-tested JUMO control algorithm with two possible optimization variants. These enable a simple and highly-accurate startup. Even multiple-zone control, cascade control, or other complex control tasks are therefore possible.

In the following block diagram, the various hardware options of the modular hardware concept are depicted. 4 analog universal inputs and up to 8 external inputs can acquire a variety of physical measured values with high precision. Thanks to different output variants, the actuators can be controlled directly in the device, either in an analog manner or digitally. These can be expanded further through external digital outputs. To communicate with higher-level systems, interfaces such as Modbus (master/slave), PROFIBUS, PROFINET-RT, or Ethernet with web server, can be used.

To ensure secure process operation, the device has password-protected user administration with individual assignment of rights for different levels or control commands. Screen masks for controllers, program generators, recording, and for overview screens are ready-made and available. Four individual process screens can be created as desired using the configuration software. Important analog and digital process values can be saved in a tamper-proof manner with the recording extra code, visualized graphically, and exported to PC in a tamper-proof manner via interface or USB flash drive.

The configuration software allows for the process controller to be programmed with ease, for math and logic coherences to be described, and for customer-specific linearizations to be created. Additionally, tools are included for simulating external signals or the control process, or to record for the duration of the startup.

A comprehensive alarm and limit value concept as well as flexible digital signal management complete the "all-in-one device".

1 Introduction

1.3 Block diagram

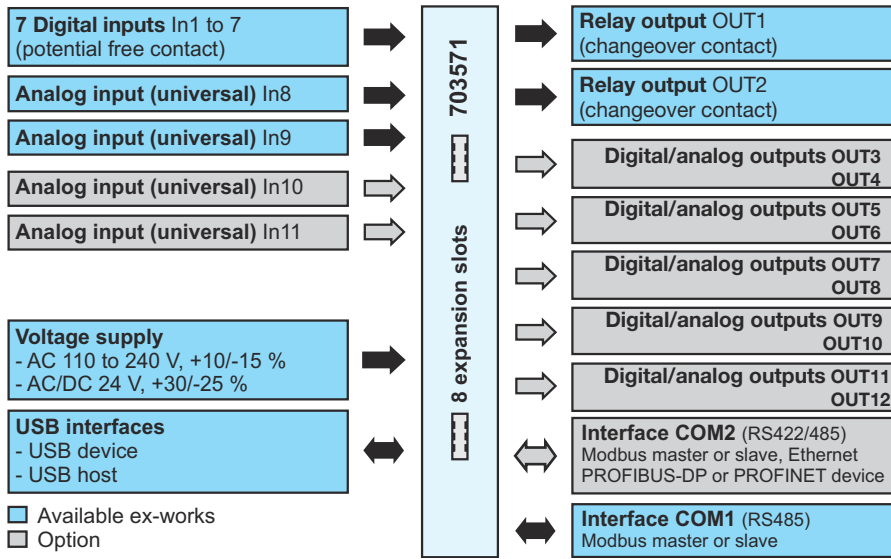

2 Identifying the device version

2.1 Order details

(1) Basic type	
703571	JUMO DICON touch - two-channel process and program controller with RS485 interface
(2) Version	
8	Standard with default settings
9	Customer-specific configuration (specifications in plain text)
(3) National language of display texts	
01	German
02	English
03	French
(4) Input IN10	
00	Not used
10	Analog input (universal)
(5) Input IN11	
00	Not used
10	Analog input (universal)
(6) Outputs OUT3/4	
00	None
11	1 relay (changeover contact)
12	2 relays (normally open)
13	1 solid state relay 230 V, 1 A
14	1 logic output 0/22 V, max. 30 mA
15	2 logic outputs 0/12 V, 20 mA
16	1 analog output
17	2 PhotoMOS® relays ¹
20	2 solid state relays 230 V, 1 A for motor actuator drives (double slot: OUT3/4 and OUT7/8)
(7) Outputs OUT5/6	
00	None
11	1 relay (changeover contact)
12	2 relays (normally open)
13	1 solid state relay 230 V, 1 A
14	1 logic output 0/22 V, max. 30 mA
15	2 logic outputs 0/12 V, 20 mA
16	1 analog output
17	2 PhotoMOS® relays ¹
20	2 solid state relays 230 V, 1 A for motor actuator drives (double slot: OUT5/6 and OUT9/10)
(8) Outputs OUT7/8 (not available for assignment with module 20 on OUT3/4)	
00	None

2 Identifying the device version

11	1 relay (changeover contact)
12	2 relays (normally open)
13	1 solid state relay 230 V, 1 A
14	1 logic output 0/22 V, max. 30 mA
15	2 logic outputs 0/12 V, 20 mA
16	1 analog output
17	2 PhotoMOS® relays ¹
(9) Outputs OUT9/10 (not available for assignment with module 20 on OUT5/6)	
00	None
11	1 relay (changeover contact)
12	2 relays (normally open)
13	1 solid state relay 230 V, 1 A
14	1 logic output 0/22 V, max. 30 mA
15	2 logic outputs 0/12 V, 20 mA
16	1 analog output
17	2 PhotoMOS® relays ¹
(10) Outputs OUT11/12	
00	None
11	1 relay (changeover contact)
12	2 relays (normally open)
13	1 solid state relay 230 V, 1 A
14	1 logic output 0/22 V, max. 30 mA
15	2 logic outputs 0/12 V, 20 mA
16	1 analog output
17	2 PhotoMOS® relays ¹
(11) Voltage supply	
23	AC 110 to 240 V +10/-15 %, 48 to 63 Hz
39	AC/DC 24 V +30/-25 %, 48 to 63 Hz
(12) Interface COM2	
00	Not used
08	Ethernet
54	RS422/485 Modbus RTU
63	PROFINET
64	PROFIBUS-DP
(13) DIN-tested	
000	Without approval
056	With DIN approval
(14) DNV GL-tested	
000	Without approval
062	With DNV GL approval

2 Identifying the device version

(15) Extra codes	
000	Without extra code
209	Controller 3 and 4
213	Recording function
214	Math and logic module 1 to 8
215	Math and logic module 9 to 16
223	Program controller
879	AMS2750/CQI-9 ²

¹ PhotoMOS is a registered trademark of the Panasonic Corporation

² For the calibration certificate, the channels to be checked must be stated along with the thermocouple type and the required measuring points.

Order code (1) - (2) - (3) - (4) (5) - (6) (7) (8) (9) (10) - (11) - (12) / (13) , (14) , (15)
 - - - - - - / , , ...¹

Order exam- 703571 - X - X - X X - X X X X X - X - X / X , X , X
 ple

¹ List extra codes in sequence and separate using commas.

2.2 Scope of delivery







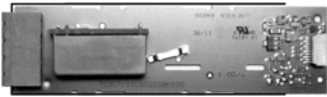
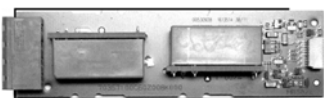

- 1 controller in the ordered version
- 1 Operating Manual
- 1 panel seal 4 retaining elements for panel installation

2.3 General accessories

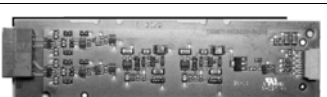
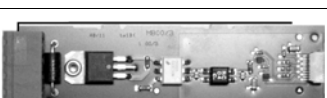
Article	Part no.
PCA3000/PCC JUMO software package 709701/709702	00431884
USB cable A-connector mini B-connector 3 m	00506252

2 Identifying the device version

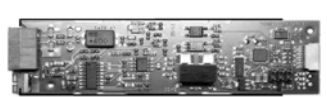
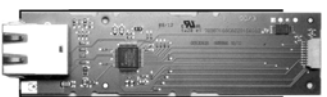
2.4 Accessories

Item		Parts no.
Modules for expansion slots:		
One analog input (universal)		00581159
One relay output (changeover contact)		00581160
Two relay outputs (N/O contact)		00581162
One logic output DC 0/22 V, max. 30 mA		00581165
Two logic outputs DC 0/12 V max. 20 mA		00581168
One solid state relay AC 230 V, 1 A		00581164
Two solid state relays AC 230 V, 1 A for motor actuator		00621574
Two PhotoMOS® relays ¹ DC 45 V, max. 200 mA, AC 30 V, max. 200 mA		00581171
One analog output (universal)		00581169
Ethernet interface		00581174
Serial interface RS422/RS485		00581172
PROFIBUS-DP interface		00581173

¹ PhotoMOS is a registered trademark of Panasonic Corporation

2 Identifying the device version

2.5 Nameplate

Position

The nameplate is affixed to the housing.

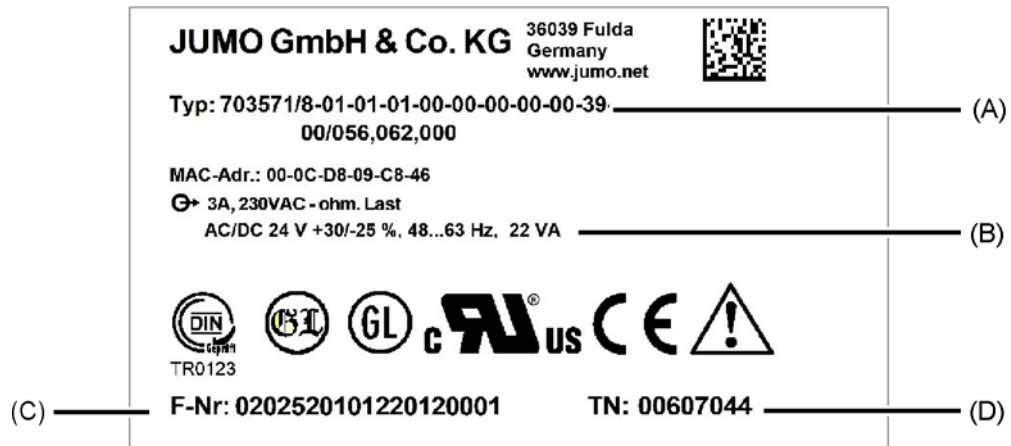

Contents

The nameplates contain important information. This includes:

Description	Designation on the nameplate
Device type (A)	Typ
Voltage supply, power consumption (B)	
Fabrication number (C)	F-Nr
Part no. (D)	TN

Device type (Typ)

Compare the specifications on the nameplate with the order.

Identify the supplied device version using the order details (order code).

Part no. (TN)

The part no. uniquely identifies an article in the catalog. It is important for communication between the customer and the sales department.

Fabrication number (F-Nr:)

Among other things, the fabrication number contains the date of production (year/week).

Example: F-Nr = 0202520101220120001

The characters in question are digits 12, 13, 14, and 15 (from the left).

The device was therefore produced in the 12th week of 2020.

Digit 11 denotes the hardware index.

0202520101220120001 means the expansion stage for 4 controllers.

1234567801013010000 means the expansion stage for 2 controllers.

2 Identifying the device version

Identifying the optional modules

The device type (Typ) also contains information about optional modules provided per default, as in the following example of the Ethernet interface (digit 08):

703571/8-01-00-00-00-00-00-00-25-08... (see order code)

Further information on identifying optional modules is included in this chapter:

⇒ Operating manual Chapter 9.2 "Slots", Page 53

3.1 Mounting site and climatic conditions

The mounting site should be free from vibration, dust and corrosive media. Install controllers as far away as possible from sources of electromagnetic fields, such as those created by frequency converters or high-voltage ignition transformers. Conditions at the mounting site must correspond to the following environmental influences:

3.1.1 Electrical data

Voltage supply Connection Voltage	At the back via screw terminals AC/DC 24 V +30/-25%, 48 to 63 Hz or AC 110 to 240 V +10/-15 %, 48 to 63 Hz	
Power consumption	At voltage supply 230 V: max. 15 VA / 7 W At voltage supply 24 V: max. 12 VA / 9 W	
Inputs and outputs Connection Conductor cross section	At the back via screw terminals Max. 2.5 mm ² , wire or strand with end sleeve	
Electrical safety	According to DIN EN 61010-1 Overvoltage category III, pollution degree 2	
Electromagnetic compatibility Interference emission Interference immunity	According to DIN EN 61326-1 Class A - For industrial applications only Industrial requirements	
Memory data recorder (1 recording image)	Memory cycle	Recording interval
When recording:	1 s	approx. 44 days
4 analog signals	5 s	approx. 220 days
3 digital signals	10 s	approx. 441 days
	60 s	approx. 2646 days (7 years, 91 days)
Note: In case of recording 2 recording images, the recording intervals are cut in an half		

3.1.2 Environmental influences

Ambient/storage temperature range	-5 to +55 °C/-30 to +70 °C
Resistance to climatic conditions	Humidity 3K3 (DIN EN 60721-3-3) with extended temperature range, rel. humidity ≤ 95 % mid-year without condensation

3.1.3 Housing

Site altitude	Maximum 2000 m above sea level
Case type	Plastic front frame with metal case barrel (for indoor use)
Front frame dimensions	96 mm × 96 mm
Panel cut-out	92 ^{+0.8} mm × 92 ^{+0.8} mm according to DIN IEC 61554

3 Mounting

Close mounting	Spacing between the panel cut-outs, min. 35 mm horizontally and min. 80 mm vertically
Panel thickness	Max. 5 mm
Mounting depth	Max. 130 mm
Fastening	4 mounting elements
Operating position (including the viewing angle of the TFT color screen)	Any Horizontal $\pm 65^\circ$, vertical $+40$ to -65°
Protection type	Front IP66, rear IP20, according to DIN EN 60529
Weight (fully fitted)	Approx. 1000 g

3.2 Dimensions

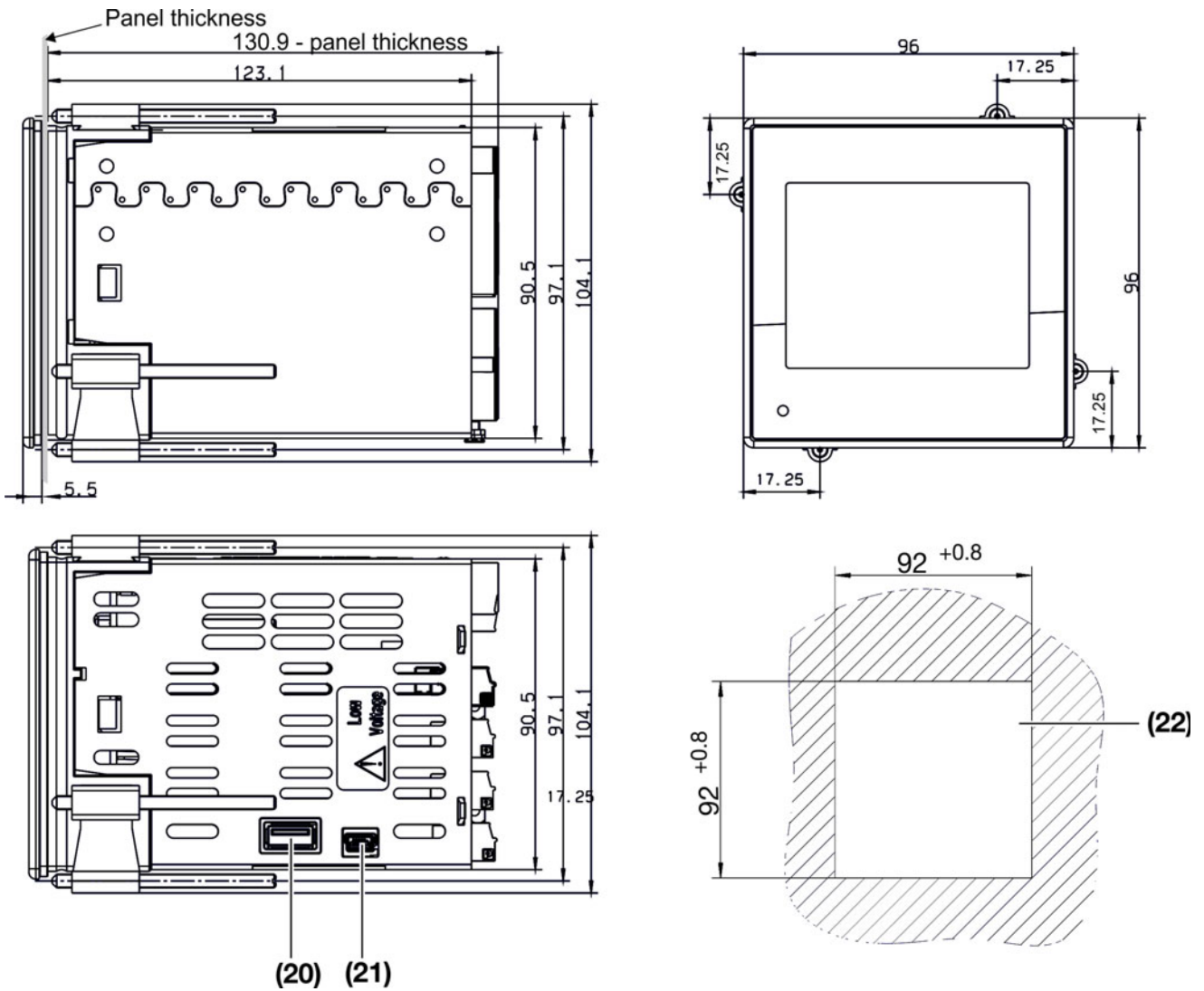

(20) USB host interface

(21) USB device interface for setup

(22) Panel cut-out

3.3 Close mounting

If several devices are mounted above or next to each other on a panel, the panel cut-outs must be positioned 35 mm horizontally and at least 80 mm vertically away from each other.

3.4 Installation in panel cut-out

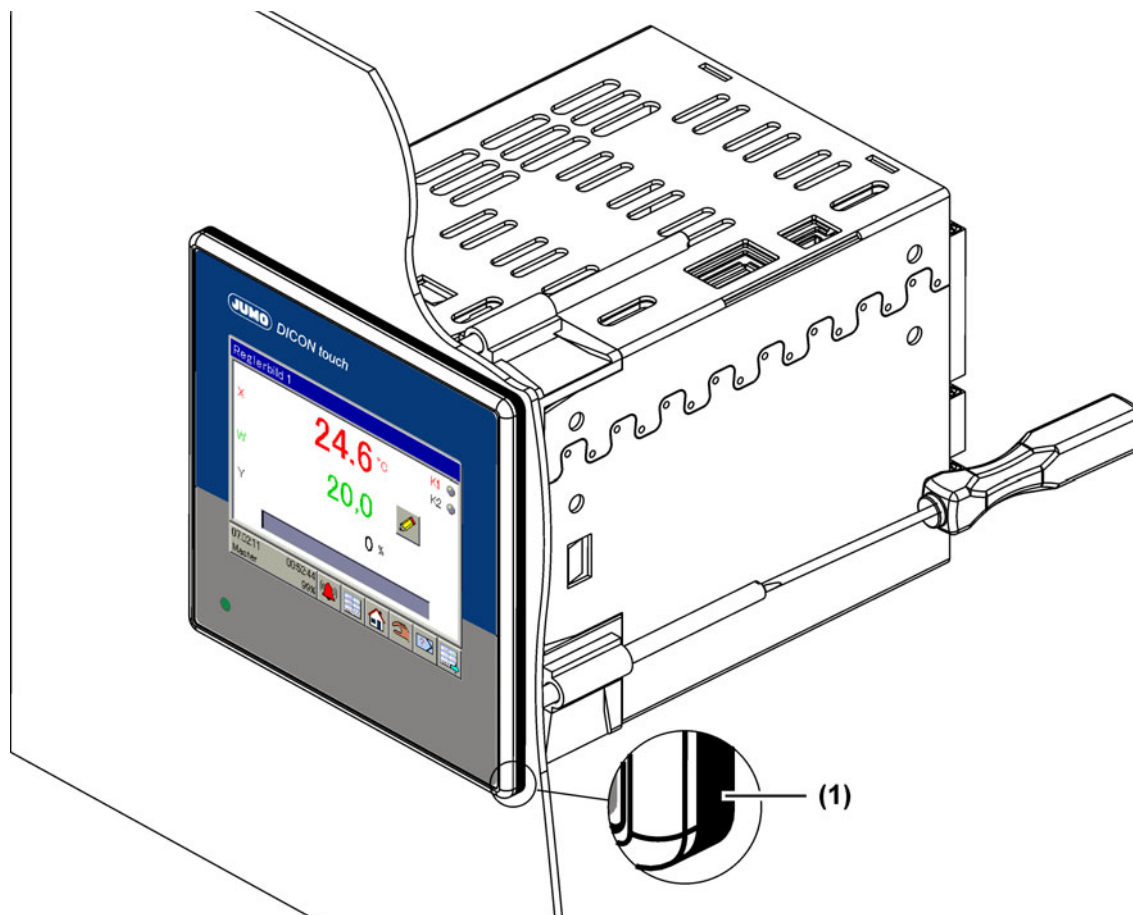

Step	Activity
1	Affix delivered panel seal (1) on the device from the rear
2	Insert the device into the panel cut-out from the front and ensure the panel seal is correctly positioned so that no water or pollutants can penetrate the housing.
3	From the panel rear, slide the mounting elements into the guides on the sides. In doing so, the flat faces of the mounting elements must make contact with the housing.
4	Place the mounting elements against the panel rear and tighten evenly with a screwdriver to max. 0.5 Nm until the controller housing is firmly positioned in the panel cut-out.

3.5 Care and treatment of the front cover

The front plate can be cleaned with commercial detergents, rinsing, and cleaning agents.

3 Mounting



NOTE!

The resistive touchscreen cover reacts to finger pressure or can be operated using commercially available pens with a rounded plastic tip.



CAUTION!

Sharp tools will cause scratches and may damage the cover.
The front plate is not resistant to corrosive acids or lyes, abrasives, or cleaning with high-pressure cleaners.
Do not use sharp objects to operate the device.

4.1 Installation notes



CAUTION!

The delivery status of the device at the first startup does not necessarily correspond to the intended application (for example, Controller 2 inactive).

This may result in undefined plant behavior.

Therefore, where possible during startup, no actuators should be connected and load current circuits should be isolated. The plant installer is essentially responsible for the startup process.

4.1.1 Lines, shielding, and grounding

When selecting the line material as well as when installing and connecting the controller electrically, the requirements of DIN VDE 0100 "Low-voltage electrical installations" and the applicable country-specific regulations (e.g. based on IEC 60364) need to be observed.

- Where possible, route input, output, and supply lines separately and not parallel to one another.
- Only use shielded and twisted probe and interface cables and where possible, route them at a distance from components or lines that are live.
- For temperature probes, ground the shielding on one side in the control cabinet.
- Do not perform loophroughs on the grounding cables, but route the cables individually to a shared grounding point in the control cabinet; in doing so, ensure that the cables are as short as possible.
- Ensure the potential equalization is correctly wired.
- At maximum load, the lines must be heat resistant up to at least 80 °C.
- When connecting the device to an external PELV electrical circuit, the existing internal SELV electrical circuit becomes a PELV electrical circuit whereby the protection against electrical shock is provided through double/reinforced insulation and voltage limitation – but here no connection to the protective ground is required.

4.1.2 Electrical safety

- The primary fuse protection for the voltage supply should not exceed a value of 20 A (slow-blow) and should not be less than 2 A.
- In order to prevent the destruction of the relay or solid state relay outputs in the event of an external short circuit in the load circuit, the load circuit should be fuse-protected to the maximum admissible output current.
- In addition to a faulty installation, incorrectly set values on the controller could also impair the correct function of the following process. Therefore, ensure that safety devices independent of the controller (for example, overpressure valves or temperature limiters/monitors) are available and that it is only possible for qualified personnel to define settings. Please observe the corresponding safety regulations in this context.
- Since not all conceivable control processes can be controlled with the self-adjustment function, the stability of the actual value reached should be monitored.
- For servicing/repair purposes, a disconnecting device is to be provided to switch off all connecting cables.

4 Electrical connection

4.1.3 Intended use, misuse

- The controller is intended for installation in the industrial sector.



WARNING!

The controller is not suitable for installation in potentially explosive areas

Explosion hazard.

The device must only be used outside of potentially explosive areas.

4.2 Galvanic isolation

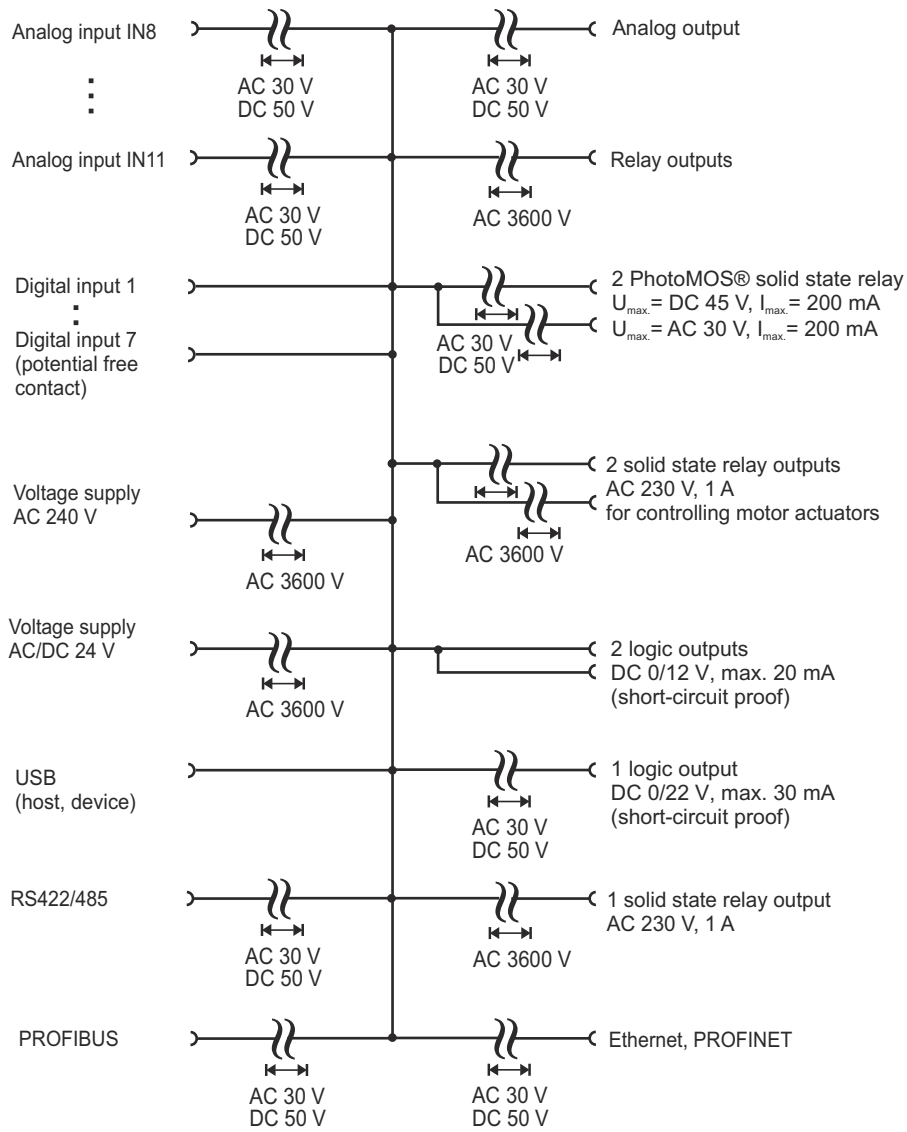

4 Electrical connection

4.3 Connection diagram



DANGER!

Works involving dangerous electrical voltage (230 V) are performed here. There is a risk of electric shock.

De-energize all electrical circuits before performing wiring work. The electrical connection must only be established by qualified personnel.

4.3.1 Connection elements

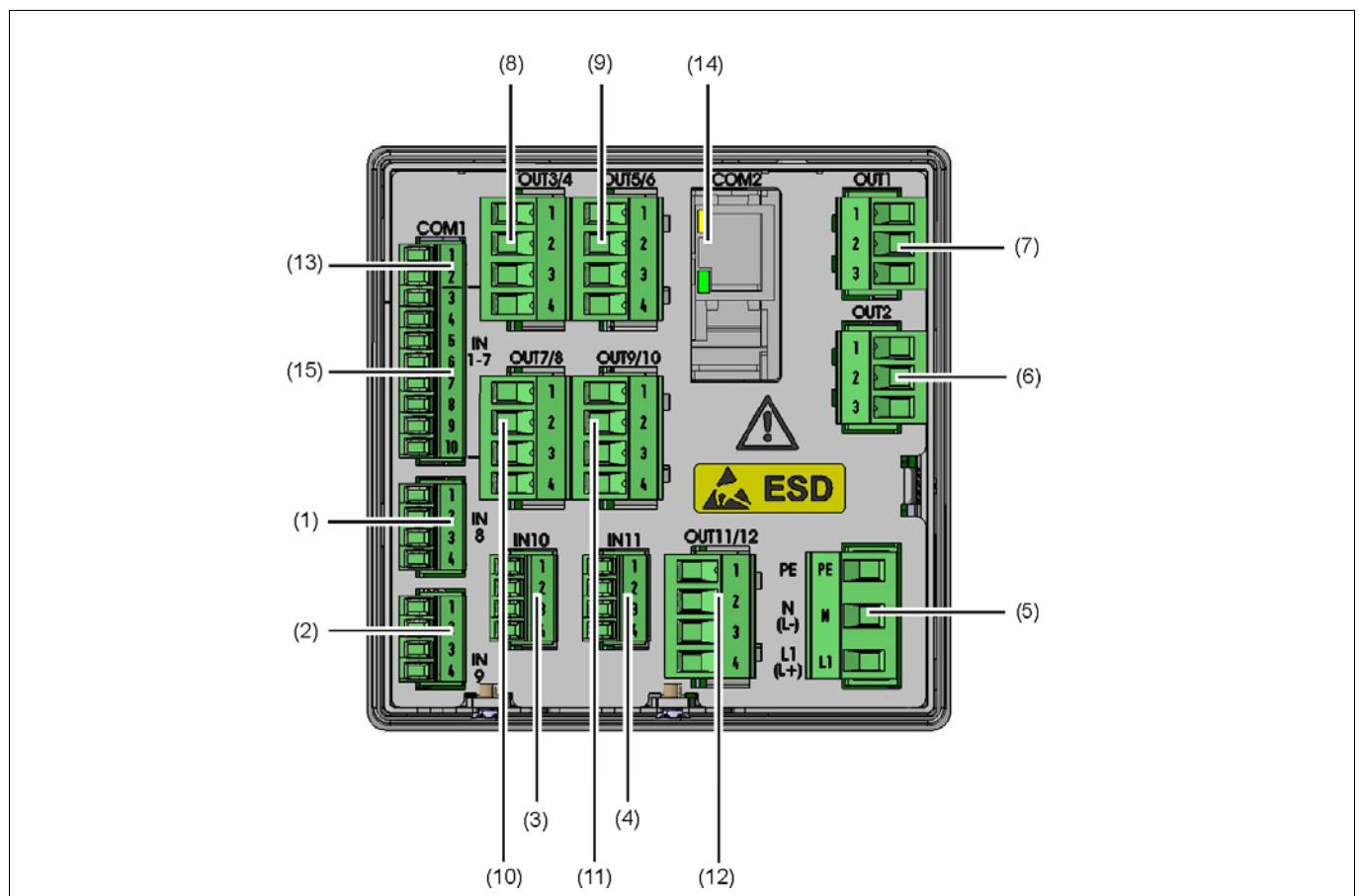

- | | |
|---|--|
| (1) Analog input IN8 | (2) Analog input IN9 |
| (3) Expansion slot for analog input IN10 | (4) Expansion slot for analog input IN11 |
| (5) Voltage supply
AC 240 V +10/-15 %, 48 to 63 Hz,
AC/DC 24 V +30/-25 %, 48 to 63 Hz | (6) Relay output OUT2 |
| (7) Relay output OUT1 | (8) Expansion slot for outputs OUT3/4 |
| (9) Expansion slot for outputs OUT5/6 | (10) Expansion slot for outputs OUT7/8 |
| (11) Expansion slot for outputs OUT9/10 | (12) Expansion slot for outputs OUT11/12 |
| (13) COM1 interface RS485 | (14) Expansion slot for COM2 interface |
| (15) Digital inputs IN1 to 7 | |

4 Electrical connection

4.3.2 Analog inputs

Input IN8, IN9 as a standard feature

2 analog inputs can be added to input (IN10), (IN11) via optional boards

Connection	(Connection element) Input	Symbol and terminal designation
Thermocouple	(1) IN8 (2) IN9 (3) IN10 (4) IN11	
RTD temperature probe Two-wire circuit		
RTD temperature probe Three-wire circuit		
Voltage DC 0(2) to 10 V		
Voltage DC 0 to 1 V		
Voltage DC 0 to 100 mV		
Current DC 0(4) to 20 mA		
Resistance transmitter		

A = Start
E = End
S = Slider

4 Electrical connection



NOTE!

Approval according to DIN EN 14597 is only valid if the correct probe with DIN approval is set in the configuration level, and also connected to the analog input. The measured value acquired in this way must lie in the approved temperature range of the DIN probe in the following tables, and can, for example, continue to be used as the actual value for the two controllers or for the limit value monitoring function.

4.3.3 Probes for air

Hinweis: Wegen der Ansprechgenauigkeit ist die Verwendung **nur ohne Schutzhülsen** (Tauchhülsen) zulässig.

aktuelle Typenbezeichnung	alte Typenbezeichnung	Fühlerart	Temperaturbereich	Nennlänge mm	Prozessanschluss
Widerstandsthermometer Typenblatt 90.2006					
902006/65-228-1003-1-15-500-668/000	-	1 x Pt100	-170 ... +700°C	500	
902006/65-228-1003-1-15-710-668/000	-			710	
902006/65-228-1003-1-15-1000-668/000	-			1000	
902006/55-228-1003-1-15-500-254/000	-	1 x Pt100	-170 ... +700°C	500	
902006/55-228-1003-1-15-710-254/000	-			710	
902006/55-228-1003-1-15-1000-254/000	-			1000	
902006/65-228-2003-1-15-500-668/000	90.271-F01	2 x Pt100	-170 ... +700°C	500	Anschlagflansch verschiebbar
902006/65-228-2003-1-15-710-668/000	90.272-F01			710	
902006/65-228-2003-1-15-1000-668/000	90.273-F01			1000	
902006/55-228-2003-1-15-500-254/000	-	2 x Pt100	-170 ... +700°C	500	verschiebbare Klemmverschraubung G1/2
902006/55-228-2003-1-15-710-254/000	-			710	
902006/55-228-2003-1-15-1000-254/000	-			1000	
Thermoelemente Typenblatt 90.1006					
901006/65-547-2043-15-500-668/000	90.019-F01	2 x NiCr-Ni, Typ „K“	-35 ... +800°C	500	Anschlagflansch verschiebbar
901006/65-547-2043-15-710-668/000	90.020-F01			710	
901006/65-547-2043-15-1000-668/000	90.021-F01			1000	
901006/65-546-2042-15-500-668/000	90.019-F11	2 x Fe-CuNi, Typ „L“	-35 ... +700°C	500	
901006/65-546-2042-15-710-668/000	90.020-F11			710	
901006/65-546-2042-15-1000-668/000	90.021-F11			1000	
901006/66-550-2043-6-500-668/000	90.023-F01	2 x NiCr-Ni, Typ „K“	-35 ... +1000°C	500	
901006/66-550-2043-6-355-668/000	90.023-F02			355	
901006/66-550-2043-6-250-668/000	90.023-F03			250	
901006/66-880-1044-6-250-668/000	90.021	1 x PT10Rh-PT, Typ „S“	0 ... 1300°C	250	
901006/66-880-1044-6-355-668/000	90.022			355	
901006/66-880-1044-6-500-668/000	90.023			500	
901006/66-880-2044-6-250-668/000	90-D-021	2 x PT10Rh-PT, Typ „S“	0 ... 1300°C	250	Anschlagflansch verschiebbar
901006/66-880-2044-6-355-668/000	90-D-022			355	
901006/66-880-2044-6-500-668/000	90-D-023			500	

901006/66-953-1046-6-250-668/000	90.027	1 x PT30Rh-PT6Rh, Typ „B“	600 ... 1500°C	250	
901006/66-953-1046-6-355-668/000	90.028			355	
901006/66-953-1046-6-500-668/000	90.029			500	
901006/66-953-2046-6-250-668/000	90-D-027	2 x PT30Rh-PT6Rh, Typ „B“	600 ... 1500°C	250	
901006/66-953-2046-6-355-668/000	90-D-028			355	
901006/66-953-2046-6-500-668/000	90-D-029			500	

4.3.4 Probes for water and oil

Hinweis: Wegen der Ansprechgenauigkeit ist die Verwendung **nur ohne Schutzhülsen** (Tauchhülsen) zulässig.

aktuelle Typenbezeichnung	alte Typenbezeichnung	Fühlerart	Temperaturbereich	Nennlänge mm	Prozessanschluss
Widerstandsthermometer (Typenblatt 90.2006)					
90.2006/10-402-1003-1-9-100-104/000		1 x Pt100	-40 ... +400°C	100	Verschraubung G1/2
90.2006/10-402-2003-1-9-100-104/000		2 x Pt100		100	
902006/54-227-2003-1-15-710-254/000	90.272-F02	2 x Pt100	-170 ... 550°C	65...670	verschiebbare Klemmverschraubung G1/2
902006/54-227-1003-1-15-710-254/000	90.272-F03	1 x Pt100		65...670	
902006/10-226-1003-1-9-250-104/000	90.239	1 x Pt100	-170 ... 480°C	250	Verschraubung G1/2
902006/10-226-2003-1-9-250-104/000	90-D-239	2 x Pt100		250	
Thermoelemente (Typenblatt 90.1006)					
901006/54-544-2043-15-710-254/000	90.020-F02	2 x NiCr-Ni, Typ „K“	-35 ... 550°C	65...670	verschiebbare Klemmverschraubung G1/2
901006/54-544-1043-15-710-254/000	90.020-F03	1 x NiCr-Ni, Typ „K“		65...670	
901006/54-544-2042-15-710-254/000	90.020-F12	2 x FeCuNi, Typ „L“		65...670	
901006/54-544-1042-15-710-254/000	90.020-F13	1 x FeCuNi, Typ „L“		65...670	

Hinweis: Wegen der Ansprechgenauigkeit ist die Verwendung **nur mit werkseitig mitgelieferten Schutzhülsen** (Tauchhülsen) zulässig.

aktuelle Typenbezeichnung	alte Typenbezeichnung	Fühlerart	Temperaturbereich	Nennlänge mm	Prozessanschluss
Widerstandsthermometer (Typenblatt 90.2006)					
902006/53-505-2003-1-12-190-815/000	90D239-F03	2 x Pt100	-40 ... +400 °C	190	
902006/53-507-2003-1-12-100-815/000	90.239-F02	2 x Pt100 (im Schutzrohr untereinander angeordnet)	-40 ... +480 °C	100	
902006/53-507-2003-1-12-160-815/000	90.239-F12			160	
902006/53-507-2003-1-12-190-815/000				190	
902006/53-507-2003-1-12-220-815/000	90.239-F22			220	
902006/53-507-1003-1-12-100-815/000	90.239-F01	1 x Pt100	-40 ... +480 °C	100	Einschweißshülse
902006/53-507-1003-1-12-160-815/000	90.239-F11			160	
902006/53-507-1003-1-12-220-815/000	90.239-F21			220	
902006/53-505-1003-1-12-190-815/000	90.239-F03	1 x Pt100	-40 ... +400 °C	190	
902006/53-505-3003-1-12-100-815/000	90.239-F07	3 x Pt100	-40 ... +400 °C	100	
902006/53-505-3003-1-12-160-815/000	90.239-F17			160	
902006/53-505-3003-1-12-220-815/000	90.239-F27			220	
902006/40-226-1003-1-12-220-815/000	90.280-F30	1 x Pt100	-170 ... +480°C	220	Einschweißshülse
902006/40-226-1003-1-12-160-815/000	90.280-F31			160	
902006/40-226-1003-1-12-100-815/000	90.280-F32			100	
Thermoelemente (Typenblatt 90.1006)					
901006/53-543-1042-12-220-815/000	90.111-F01	1 x Fe-CuNi Typ „L“	-35 ... 480°C	220	Einschweißshülse
901006/53-543-2042-12-220-815/000	90.111-F02	2 x Fe-CuNi Typ „L“		220	

4.3.5 Probes for water, oil, and air

Hinweis: Wegen der Ansprechgenauigkeit ist die Verwendung **nur ohne Schutzhülsen** (Tauchhülsen) zulässig.

aktuelle Typenbezeichnung	alte Typenbezeichnung	Fühlerart	Temperaturbereich	Einbaulänge mm	Prozessanschluss
Widerstandsthermometer (Typenblatt 90.2006)					
90.2006/10-390-1003-1-8-250-104/000	90.210-F95	1 x Pt100	max. 300°C	250	
Thermoelemente (Typenblatt 90.1006)					
901006/45-551-2043-2-xxxx-11-xxxx		2 x NiCr-Ni, Typ „K“	max. 1150°C	50...2000	

4 Electrical connection

4.3.6 Analog outputs

Output OUT 3/4 to 11/12 can be extended by 1 analog output using optional boards

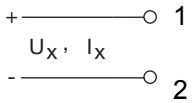
Connection	(Connection element) Input	Symbol and terminal designation
1 analog output DC 0/2 to 10 V or DC 0/ 4 to 20 mA (configurable)	(8) OUT3/4 (9) OUT5/6 (10) OUT7/8 (11) OUT9/10 (12) OUT11/12	

4.3.7 Digital inputs

Input IN1 to 7 as a standard feature (cannot be extended)

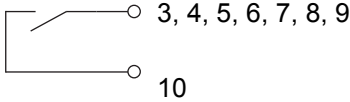
Connection	(Connection element) Input	Symbol and terminal designation
Digital input, potential-free contact as a standard feature	(15) IN1 to 7	

4.3.8 Digital outputs

OUT1 and OUT2 as a standard feature

The controller is equipped with 2 relay outputs (changeover contacts) as a standard feature.

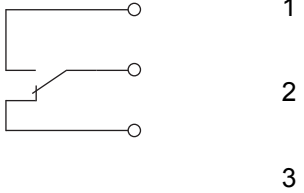
Connection	(Connection element) Output	Symbol and terminal designation
Relay output (changeover contact)	(6) OUT2 (7) OUT1	

4 Electrical connection

Outputs OUT 3/4 to 11/12 can be expanded via the following optional boards

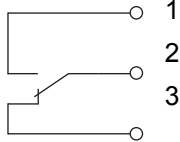
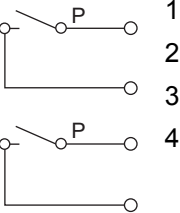
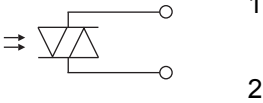
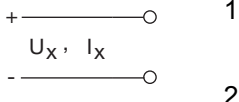
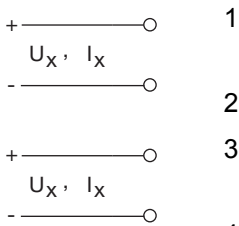
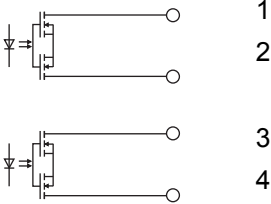
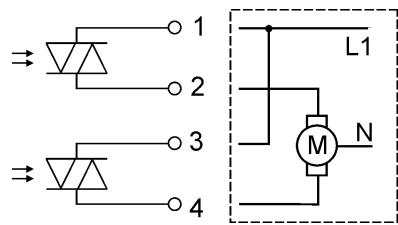
Connection	(Connection element) Output	Symbol and terminal designation
1 relay output (changeover contact)	(8) OUT3/4 (9) OUT5/6 (10) OUT7/8 (11) OUT9/10 (12) OUT11/12	
2 relay outputs (N/O contact) ¹		
1 solid state relay AC 230 V, 1 A		
1 logic output DC 0/22 V, max. 30 mA (short-circuit proof)		
2 logic outputs DC 0/12 V max. 20 mA (short-circuit proof, not galvanically isolated from each other)		
2 PhotoMOS® relays ² max. DC 45 V, 200 mA max. AC 30 V, 200 mA (galvanically isolated)		
2 solid state relays AC 230 V, 1 A (for controlling the left and right-hand motor actuators, galvanically isolated)		

¹ Combining mains voltage and protective low-voltage circuits on a 2-way N/O contact option is not admissible.

² PhotoMOS is a registered trademark of the Panasonic Corporation.

4 Electrical connection

4.3.9 Digital outputs

Standard

Two relay outputs (changeover contact)	
Switching capacity AC	AC 230V/24V; 3(0,5) A; $\cos\varphi=1(\geq 0,6)$; D300
Switching capacity DC	DC 24V; 3(0,5; $\tau =7\text{ms}$) A
Contact life	250,000 operations at nominal load

Per optional board

One relay output (changeover contact)	
Switching capacity AC	AC 230V/24V; 3(0,5) A; $\cos\varphi=1(\geq 0,6)$; D300
Switching capacity DC	DC 24V; 3(0,5; $\tau =7\text{ms}$) A
Contact life	250,000 operations at nominal load
Two relay outputs (N/O contact) ¹	
Switching capacity AC	AC 230V/24V; 3(0,5) A; $\cos\varphi=1(\geq 0,6)$; D300
Switching capacity DC	DC 24V; 3(0,5; $\tau =7\text{ms}$) A
Contact life	250,000 operations at nominal load
One solid state relay	
Switching capacity	1 A at AC 230 V, resistive load
Protection circuitry	Varistor
Two solid state relay for motor actuators	
Switching capacity	1 A at AC 230 V,
Protection circuitry	RC combination
One logic output (voltage supply for transmitter)	DC 0/22 V, max. 30 mA (short-circuit proof)
Two logic outputs	DC 0/12 V max. 20 mA (short-circuit proof, not galvanically isolated)
Two PhotoMOS® relays ²	DC 45 V, max. 200 mA, (galvanically isolated from each other, not short-circuit proof) AC 30 V, max. 200 mA, (galvanically isolated from each other, not short-circuit proof)

¹ Combining a mains voltage circuit with a protective low-voltage circuit on the "dual normally open contact" option is not admissible.

² PhotoMOS is a registered trademark of Panasonic Corporation.

4.3.10 Voltage supply (according to nameplate)

AC 230V (DC 24V)

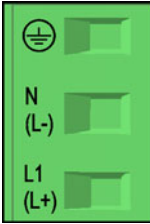

4 Electrical connection

Connection	(Connection element)	Symbol and terminal designation
Protection conductor	PE	 PE
Neutral conductor	N (L-)	N
Line conductor	L1(L+)	L1

4 Electrical connection



4.3.11 Interfaces

USB device, USB host and COM1 interfaces as a standard feature

Connection	(Connection element)	Symbol and terminal designation
USB device interface	(21)	
USB host	(20)	
COM1 serial interface RS485 (galvanically isolated)	(13)	 1 TxD+/RxD+ Transmission/ 2 TxD-/RxD- received data + Transmission/ received data -

4 Electrical connection

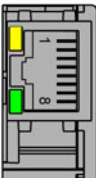
COM2 interface can be expanded using optional boards

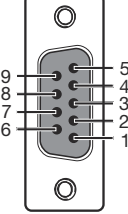
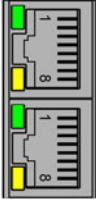
Connection	(Connection element)	Symbol and terminal designation
Ethernet	(14)	 <ul style="list-style-type: none"> 1 TX+ Transmission data + 2 TX- Transmission data - 3 RX+ Received data + 6 RX- Received data -
Serial interface RS422 (galvanically isolated)		 <ul style="list-style-type: none"> 1 RxD+ Received data + 2 RxD- Received data - 3 TxD+ Transmission data + 4 TxD- Transmission data -
Serial interface RS485 (galvanically isolated)		 <ul style="list-style-type: none"> 3 TxD+/RxD+ Transmission/ received data + 4 TxD-/RxD- Transmission/ received data -
PROFIBUS-DP		 <ul style="list-style-type: none"> 3 RxD/TxD-P (B) Data wire B+ Ground 5 DGND Voltage supply 6 VP (+5 V) Data wire (A) - 8 RxD/TxD-N (A)
PROFINET-RT		 <ul style="list-style-type: none"> 1 TX+ Transmission data + 2 TX- Transmission data - 3 RX+ Received data + 6 RX- Received data -

4 Electrical connection

5.1 Display and operating concept

The DICON touch is operated via a resistive touchscreen and also reacts to finger pressure. Commercially available pens with plastic tips can also be used.

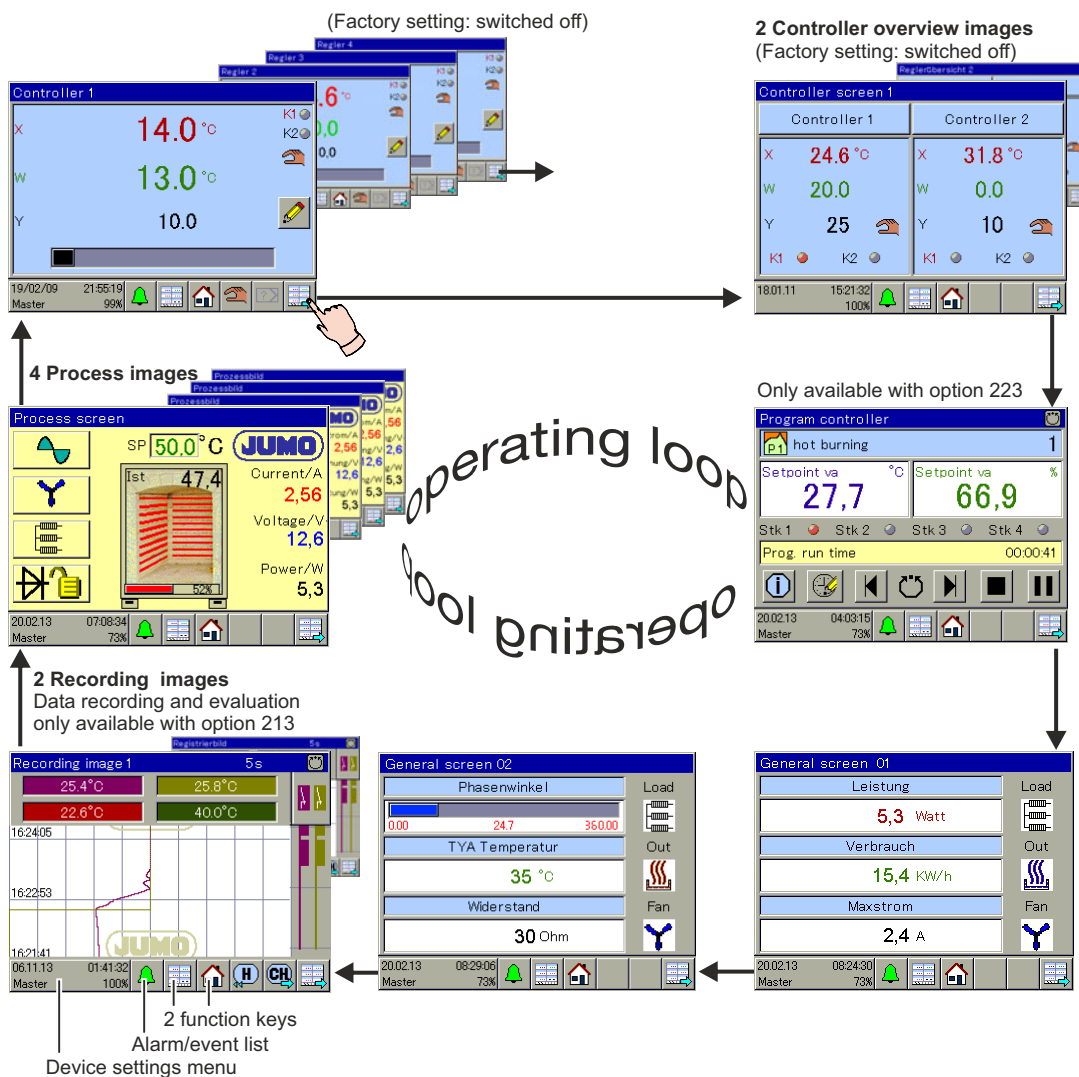
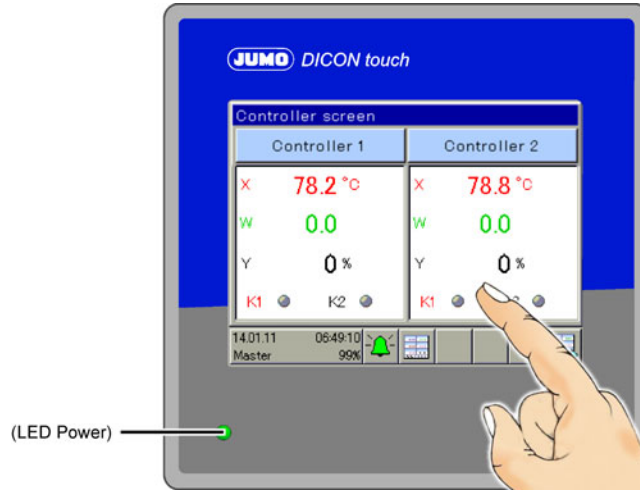

5 Operation

5.2 Device menu

All the functions in the device menu are described in the following sections of the operating manual.

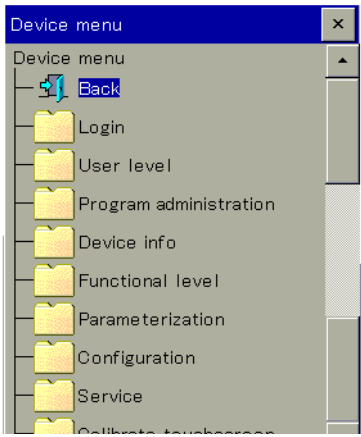
	Chapter 6 "Login", Page 45
	Operating manual Chapter 7 "User level (Log-In)", Page 47
	Chapter 8 "Program administration", Page 49
	Operating manual Chapter 10 "Functional level", Page 57
	Operating manual Chapter 11 "Parameterization", Page 59
	Operating manual Chapter 12 "Configuration", Page 67
Calibrating the touchscreen: Chapter 14 "Special functions", Page 171	

5.3 Alarm and event list

These lists show alarms and events, some of which are predefined. Additional entries can be configured such that they appear in the lists.

- ⇒ Operating manual Chapter 12.9.5 "Alarm", Page 111
- ⇒ Operating manual Chapter 12.5.1 "Alarms", Page 78

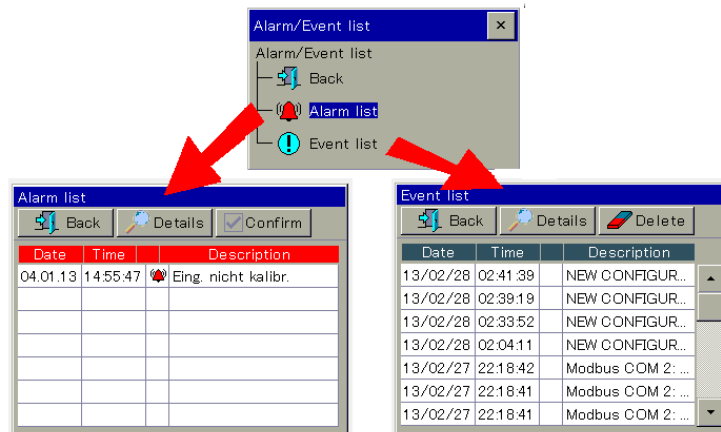

5.4 Function buttons, history, and channel changeover

Both these function buttons are set per default to "Operating level" and "Home" (back to main view) and are configurable.

- ⇒ Operating manual Chapter 12.10.1 "General configuration", Page 112
- The "History" (H) and "Channel changeover" (Ch) buttons enable navigation in the recorder screen and change their meaning according to the dialog.
- ⇒ Chapter 5.5.4 "Recording view 1, 2", Page 43

5.5 Screens in the operating loop

Start screen

After switch-on, the globe appears until the device software is started up.



Then controller screen 1 appears (default setting).

Using the icon in the bottom right-hand corner, all the screens defined in the operating loop can be called up one after another.

- ⇒ For the screen settings, see the operating manual Chapter 12.10 "Screen", Page 112
- ⇒ For information on which screens are displayed, see operating manual Chapter 12.10.4 "Operation loop", Page 114

5.5.1 Controller screen 1 to 4 and controller overview screens 1, 2

These screens can be edited in the setup program.

- ⇒ Chapter 12.10.6 "Colors, designations in controller screen 1 to 4", Page 116

Default setting

Fixed-setpoint controller and Controller 1 are set up.

In order to function properly, the controller requires an actual value, a setpoint value, and an output that influences the actual value (for example, a heat source via a relay as a two-state controller). Autotuning can only detect new parameters with a closed control loop.

- ⇒ Chapter 12.6.3 "Controller self-optimization", Page 84

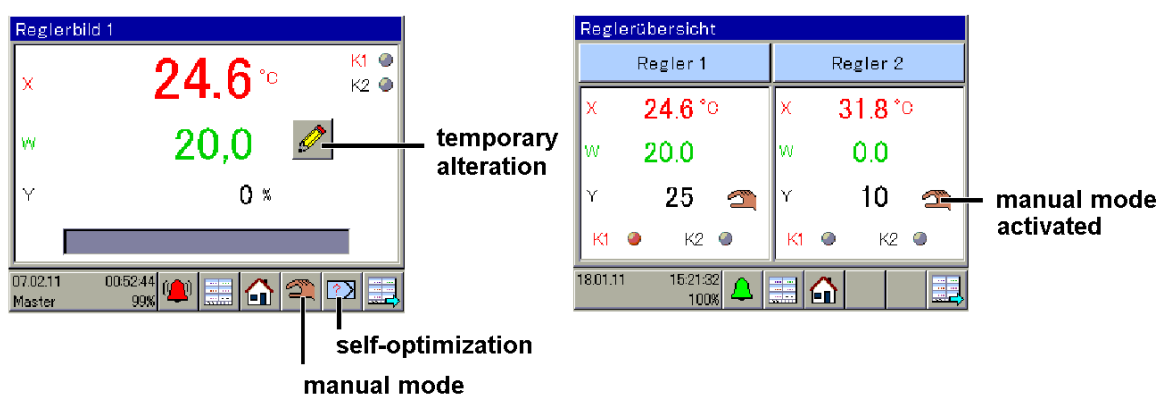

If lines or arrows appear, check the configuration or the connection.

- ⇒ Chapter 16 "Error and alarm messages", Page 181

Entering setpoint values on the device for the fixed-setpoint controller

- ⇒ Chapter 11.4 "Setpoint values", Page 64



Entering setpoint values for the fixed-setpoint controller using the setup program

- ⇒ Chapter 11.4 "Setpoint values", Page 64

5 Operation

Starting manual mode

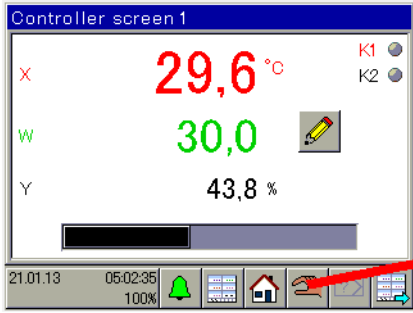
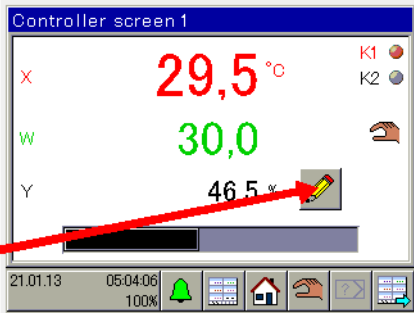
In manual mode, a particular output level is specified for the controller. First of all, the screens show the active controller, where the output level is at approx. 40 %.

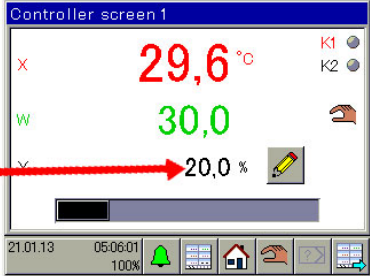
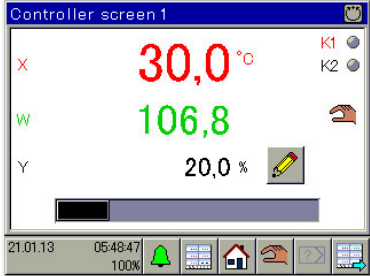
Step	Activity
1	Touch the hand symbol (pencil appears at output level display) <div style="display: flex; justify-content: space-around; margin-top: 10px;">   </div>
2	Touch the pencil, enter the manual output level, and confirm (green arrow) <div style="text-align: center; margin-top: 10px;">  </div>
3	The controller operation is interrupted and Controller 1 is now working with a fixed output level of 20 % (the hand symbol appears next to the green setpoint value). You can view the difference between the fixed-setpoint controller and the program controller at the automatic operation icon in the top right-hand corner. The green setpoint value continues, as programmed. <div style="display: flex; justify-content: space-around; margin-top: 10px;">    </div>

➔ You can now manually influence the output level (by hand)

Exiting manual mode

By touching the hand at the bottom, you can exit manual mode and return to normal control operation.

Autotuning

⇒ Operating manual Chapter 12.6.3 "Controller self-optimization", Page 84

5.5.2 Program controller



NOTE!

This screen is not available per default and only appears if the extra code for the program controller has been enabled and configured.

⇒ Chapter 2.1 "Order details", Page 13

Default setting

There are no programs available. The following options are available for creating a program:

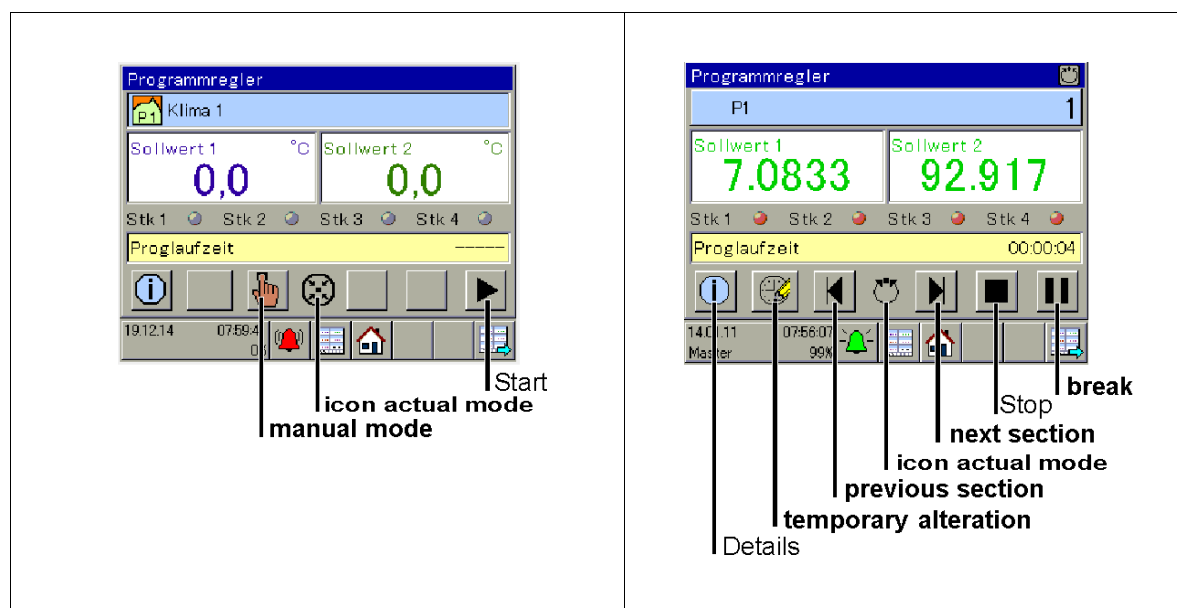

Entering setpoint curves on the device

⇒ Chapter 8.1.1 "On the device", Page 49

Entering setpoint curves using the setup program

⇒ Chapter 8.1.2 "About the setup program", Page 50

Start, Stop

The black arrow starts an available program. A prompt appears asking which program should be started and the programmed setpoint curves then run in sync for both control channels. The symbol for automatic operation appears in the center. Touching the black rectangle stops the program, and the statuses prior to the program starting are adopted again.

Pause

Pauses the time base of a program that is running, whereby the current setpoint values and the statuses of the operating contacts are maintained. Touching the pause button again resumes program operation at the same point.

Next section, previous section

The program that is running jumps to the next or previous section.

Temporary change

Allow one-time changes to the setpoint values for a program without storing it permanently in the program table. When you next run the program, the original setpoint values will be reactivated.

5 Operation

Starting/stopping manual mode (for program controller)

In the case of the program controller, manual mode can only be started by pressing the hand button when the program is stopped. After touching the hand with the pencil, the dialog for entering setpoint values 1 and 2 opens. After pressing the OK button, these setpoint values are used for the control.

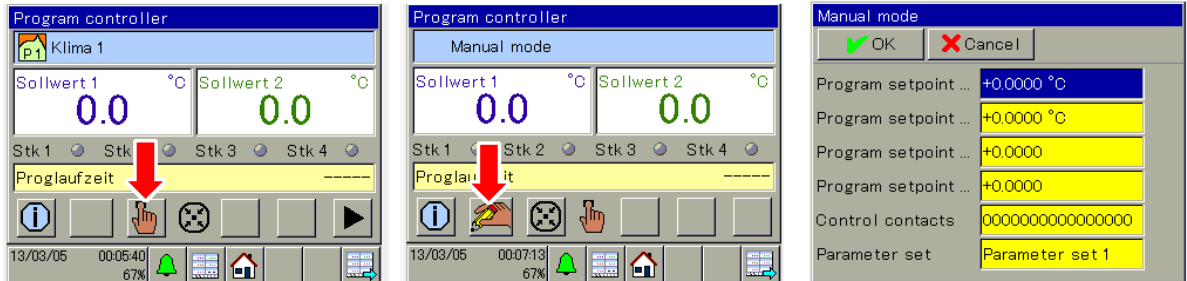

Autotuning

⇒ Operating manual Chapter 12.6.3 "Controller self-optimization", Page 84

5.5.3 General screens 1, 2

Default setting

2 general screens are available that do not contain any variables.

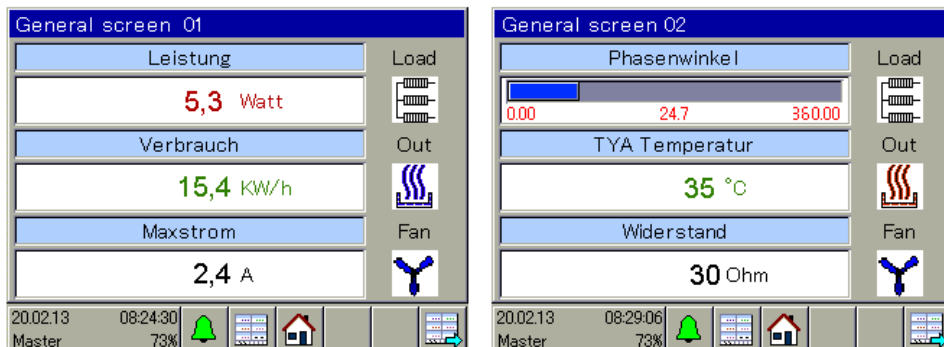

The variables to be displayed can be configured.

⇒ Operating manual Chapter 12.10.8 "General screens 1, 2", Page 118

5.5.4 Recording view 1, 2

Default setting

Here the device records up to 4 analog and 3 digital channels, like a line recorder. Extra code 213 is required if data is to be recorded and evaluated.

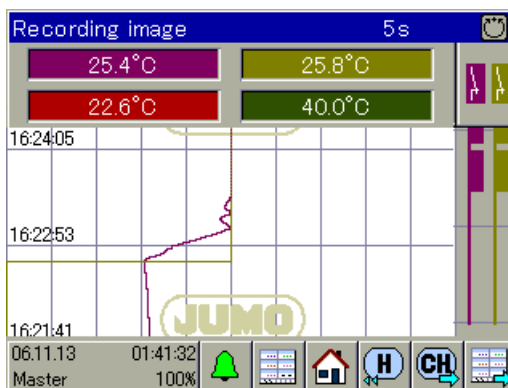

You can view historical data (from previous recordings) with the H button and switch channels with the CH button. If the channels to be displayed have been configured, the screen must be activated for the display in the operating loop.

⇒ Operating manual Chapter 12.11 "Recording 1, 2", Page 120

5.5.5 Process screen 1 to 4

Default setting

These screens can be freely configured and are blank per default. A background image of your plant can be stored and animated with all the process values for the device.

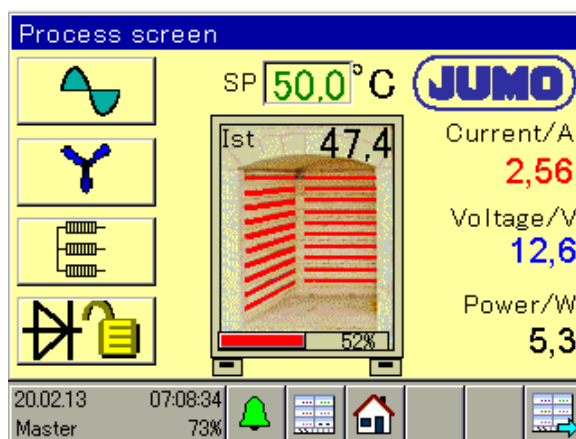

The setup program is required to design the graphics.

⇒ Operating manual Chapter 13.13 "Process screens 1 to 4", Page 163

5 Operation

6 Login

Some of the levels in the device menu are protected with a username and password. The level protection is defined in the form of 5 different users in the user list using the setup program. On entering the password, each user is entitled to use the "rights" available.

Dicon touch:				
User	1	2	3	4
ID	Master	User 1	User 2	Service
default setting	9200	1	2	300

If permitted, the rights and passwords can also be changed on the device.

2 function buttons

Alarm- and eventlist

Device settings menu

Touching the button in the bottom left-hand corner opens the device menu window.
Touching the 'Login' function opens the Login window.

6 Login

6.1 Login

This sequence shows the login process as the master user (with the default password 9200):

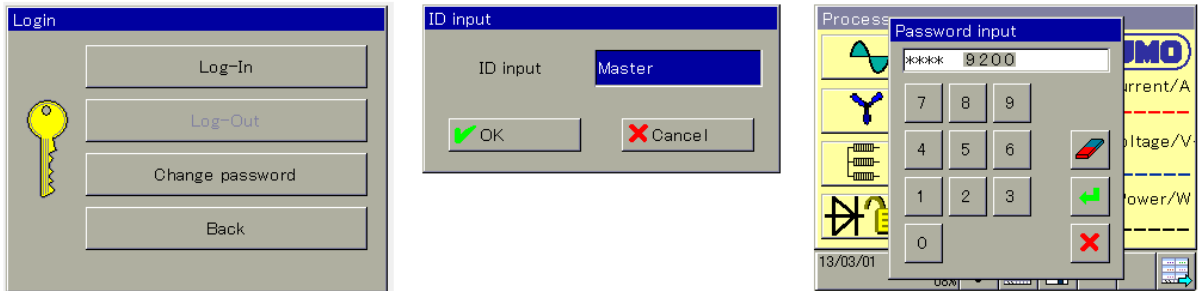

User 1 is now logged in and is permitted to access all functions listed under "Rights".

6.2 Logout

As soon as you are logged in, the Log-Out button is no longer grayed out and touching it will enable you to log out. Your user rights will be limited again thereafter.

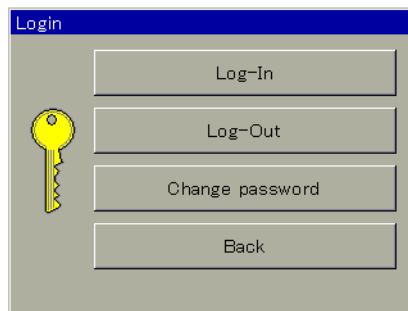

6.3 Changing the password

You can change the user password that you are currently logged in with here. To do this, you must first enter the old password (for the master user) and then the new one. If the password is incorrect, the change will not be accepted.



7 User level (Log-In)



NOTE!

This level is empty by default and parameters can only be defined using the setup program to appear in the device.

Up to 25 parameters of any type from the configuration or parameter level can be included in this level. These parameters, for example, often need to be changed or made available to operating personnel.

ONLY SETUP > USER LEVEL

Setup dialog box

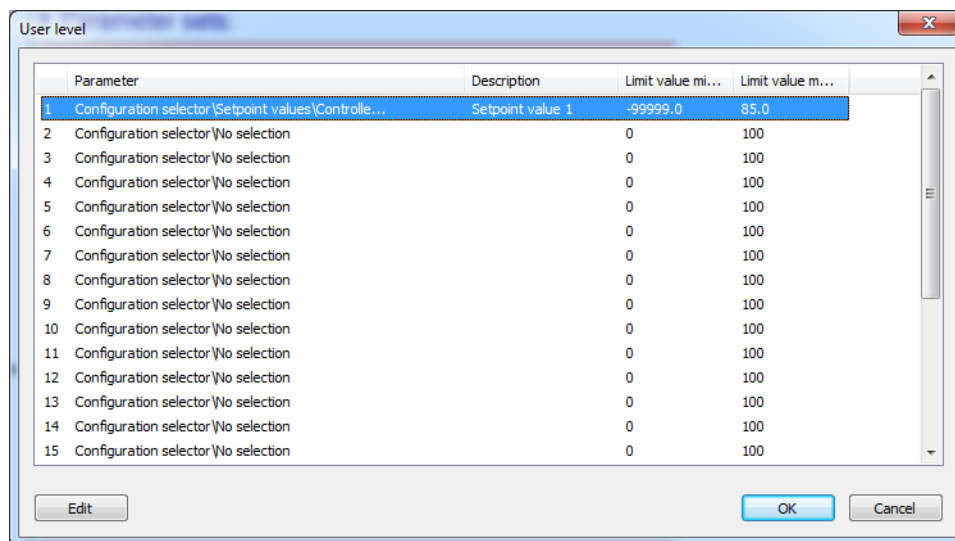

7.1 Example 4 Transferring controller setpoint values to the user level

The 4 switchable controller setpoint values are to be transferred to the user level. Double-clicking on the empty entry opens the selector window.

7 User level (Log-In)

Setup dialog box

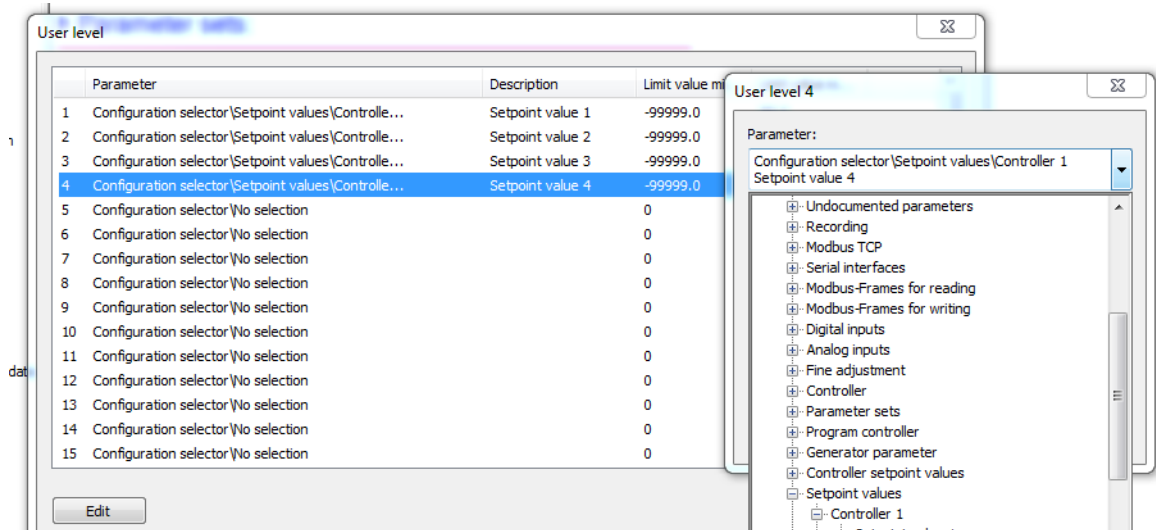

Device display

Once the setup data has been transferred to the device, the setpoint values can be entered on the device.

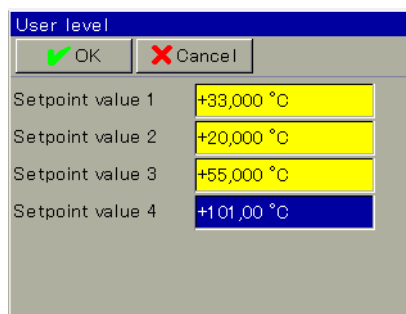

8.1 Entering program profiles

32 programs can be entered on the device or in the setup program.

8.1.1 On the device

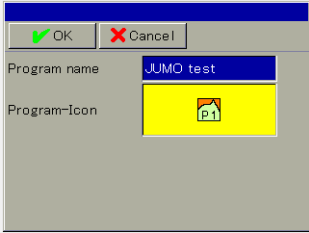
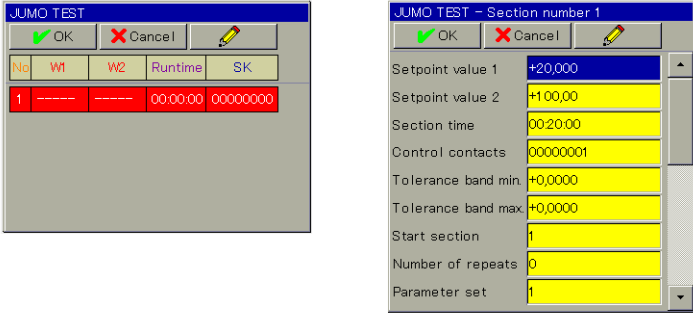
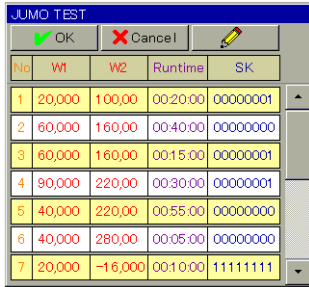
Step	Activity
1	<p>Enter program names and icons</p> 
2	<p>Enter first section: If the program memory is empty, the section will be highlighted in red.</p>  <p>Each section consists of: setpoint values 1 and 2, section time, operating contacts, tolerance band, number of repetitions from start section, and parameter block.</p>
3	<p>Using the pencil symbol, repeat the section entries until the table is complete</p> 
4	<p>Touching the pencil symbol enables additional editing functions.</p> <ul style="list-style-type: none"> • Editing the program header • Copying and deleting the program • Creating a new section

- ➔ 2 program profiles have now been programmed.
They can be started at any section at a configurable time and run in parallel.

8 Program administration

8.1.2 About the setup program

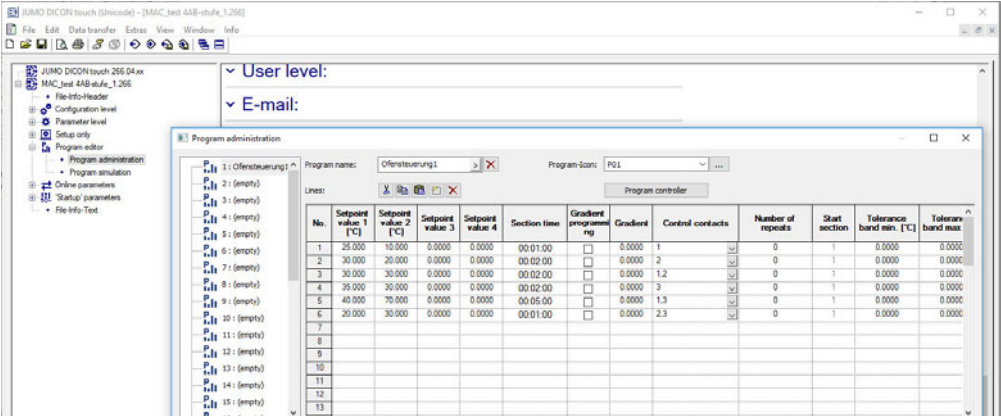
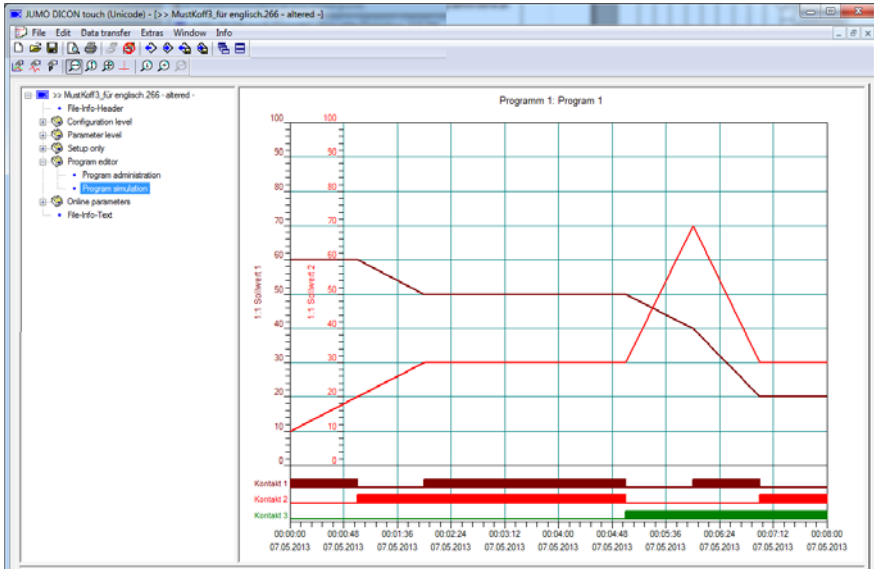
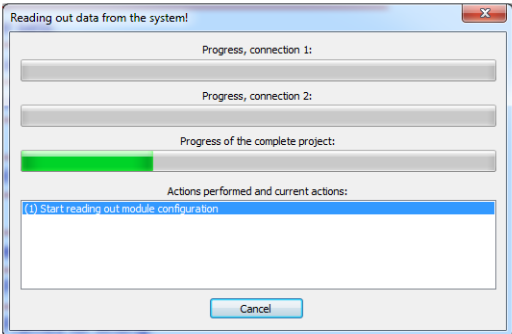
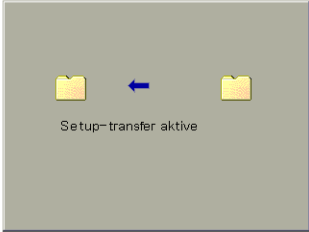
Step	Activity
1	<p>Start the setup program and click on Program editor > Program administration in the menu</p> 
2	<p>Enter sections in the table</p>
3	<p>The table is displayed as a graphic with the program simulation</p> 
4	<p>Save the setup file and transfer the setup data to the device</p>  

8 Program administration

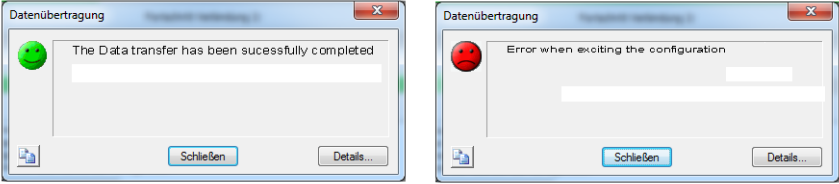
Step	Activity
5	If a green icon (smiley) appears, then the programs have been successfully transferred. 

➔ 2 program profiles have now been saved in the device and can be started at any section at a configurable time. The programs run in parallel.

8.1.3 Section run time

The period of time until the next section.

Setpoint values varying from section to section create a ramp-like setpoint value progression (with a negative or positive slope).

8.1.4 Setpoint value 1 to 4

Each program contains 4 setpoint value profiles which can be used to implement 4 program controllers.

8.1.5 Operating contacts

16 operating contacts can be set in sections. They are available in the digital selector and can switch relays, for instance.

⇒ Setup program:

CONFIGURATION LEVEL > DIGITAL OUTPUTS

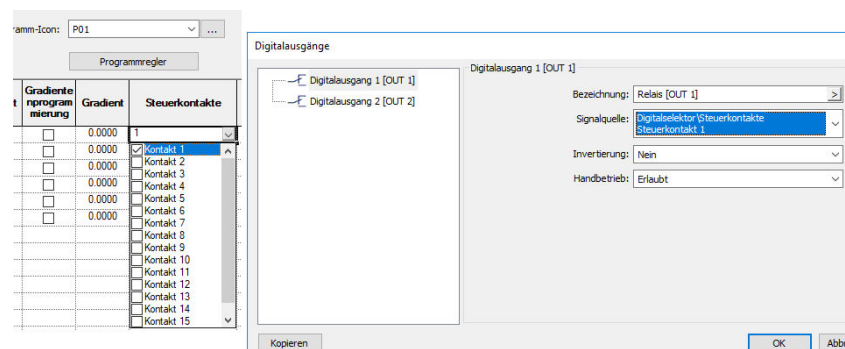

They can also be logically linked or can trigger internal device functions.

8.1.6 Tolerance band

The tolerance band max. value is above the programmed setpoint value curve and the min. value is below the curve. Both values can be variably adjusted for each section.

The function behaves in the same way as for the ramp function or the symmetrical program tolerance band. The tolerance band limit that is reached first stops the program.

⇒ Chapter 12.6.8 "Ramp function", Page 99 and
Chapter 12.12 "Program controller", Page 123

8 Program administration

8.1.7 Number of repetitions

The number of repetitions from a specific start section is entered here.

8.1.8 Start section

Repetition begins from this section.

Example

No.	Setpoint value 1	Setpoint value 2	Section time	Gradient programming	Gradient	Control contacts	Number of repeats	Start section	Tolerance band min.	Tolerance band max.	Parameter
1	60.000	10.000	00:01.00	0	0.0000	1	0	1	0.0000	0.0000	1
2	60.000	20.000	00:01.00	0	0.0000	2	0	1	0.0000	0.0000	1
3	50.000	30.000	00:03.00	0	0.0000	1,2	0	1	0.0000	0.0000	1
4	50.000	30.000	00:01.00	0	0.0000	3	0	1	0.0000	0.0000	1
5	40.000	70.000	00:01.00	0	0.0000	1,3	0	1	0.0000	0.0000	1
6	20.000	30.000	00:01.00	0	0.0000	2,3	3	4	0.0000	0.0000	1
7											
8											
9											
10											
11											
12											
13											
14											

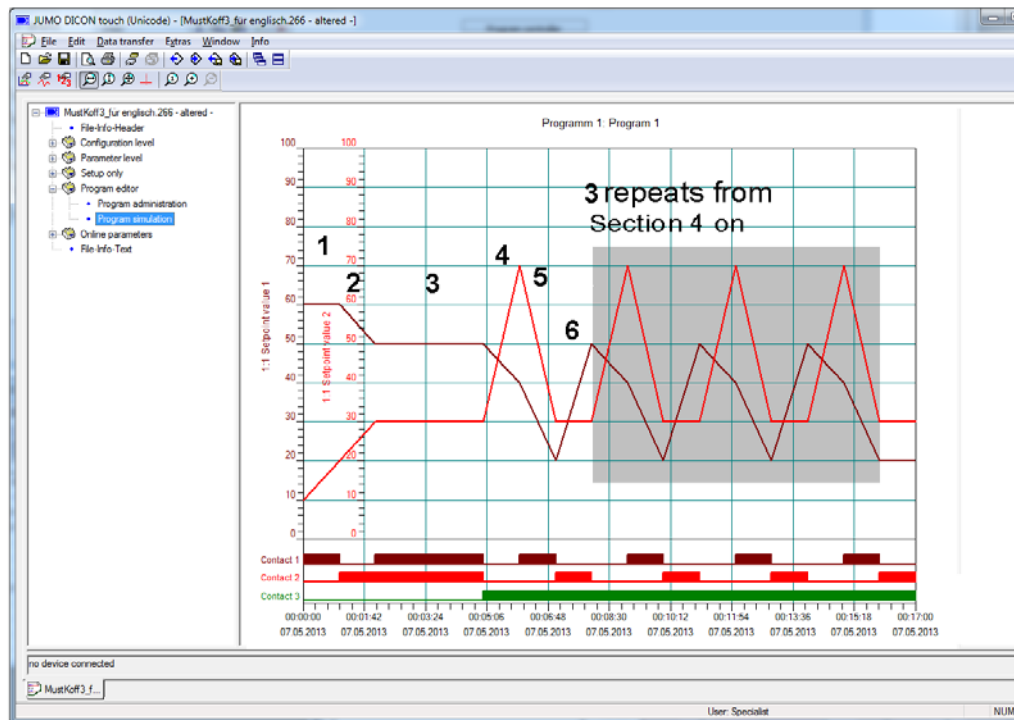

8.1.9 Parameter block

For each control channel, parameter blocks 1 to 4 are available and can be switched over in sections.

The configured parameter block relates to all controllers. Selecting a parameter block via a digital signal takes priority over selecting a parameter block in the program administration.

⇒ Chapter 11.3 "Controller/parameter blocks", Page 60 and

Chapter 12.6.2 "Controller inputs", Page 82

The device information function enables hardware and software modules to be displayed.

9.1 General information

The extra codes enabled in the device are displayed alongside the device name.

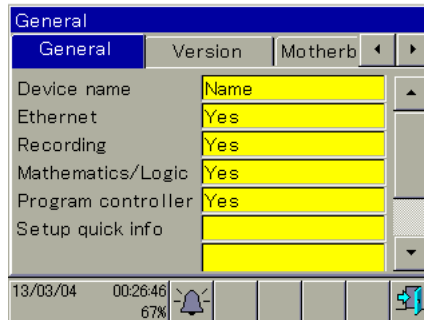

9.1.1 Version, motherboard, Ethernet information

Software version, fabrication number, and testing ID are displayed.

Displays the hardware on the motherboard.

MAC address, IP address, gate address, DNS address, and transfer rate.

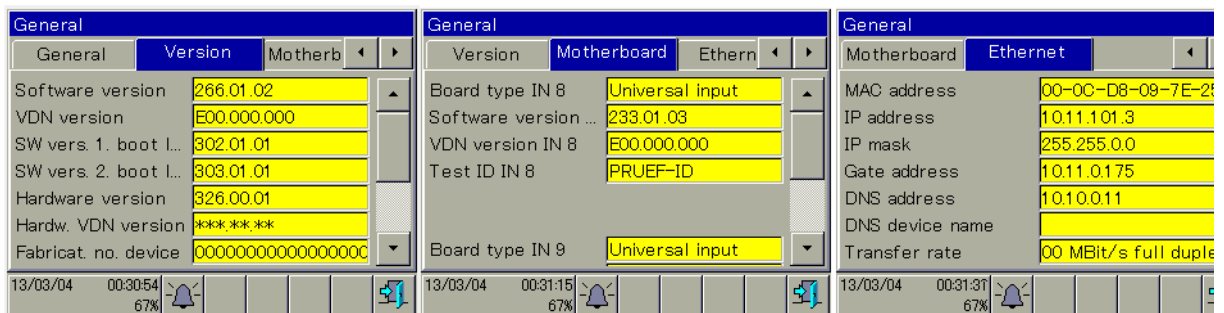

9.2 Slots

The assignment of the expansion slots in the device is displayed here.

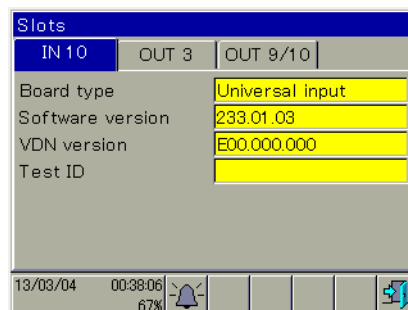

9 Device info

9.3 Inputs/outputs

The switching statuses and measured values are displayed here.

9.3.1 Digital and analog inputs, digital and analog outputs, external digital, and external analog inputs

The figure displays six screenshots of the device's 'Inputs/Outputs' interface, arranged in a 3x2 grid. Each screenshot shows a different view of the device's status and measured values.

- Top Left:** 'Inputs/Outputs' - 'Digital inputs' view. Shows IN 1 to IN 7 with values 1, 1, 0, 0, 0, 0, 0. Status: 13/03/04 00:46:36 67%.
- Top Right:** 'Inputs/Outputs' - 'Analog inputs' view. Shows IN 8: 21.686 °C, IN 9: 20.945 °C, IN 10: ---- %, IN 11: ---- %. Status: 13/03/04 00:47:18 67%.
- Middle Left:** 'Inputs/Outputs' - 'Digital outputs' view. Shows OUT 1 to OUT 11 with values 0, 0, 0, 0, 0, 0, 0, 0, 0, 0, 0. Status: 13/03/04 00:47:59 67%.
- Middle Right:** 'Inputs/Outputs' - 'Analog outputs' view. Shows OUT 3: 8,1201 mA, OUT 4: 40,601 %, OUT 5 to OUT 11: 0.0000 V. Status: 13/03/04 00:49:13 67%.
- Bottom Left:** 'Inputs/Outputs' - 'External digital inputs' view. Shows 1: 0, 2: 0, 3: 0, 4: 0, 5: 0, 6: 0, 7: 0, 8: 0. Status: 13/03/04 00:50:35 67%.
- Bottom Right:** 'Inputs/Outputs' - 'External analog inputs' view. Shows 1: ---- %, 2: ---- %, 3: ---- %, 4: ---- %, 5: ---- %, 6: ---- °C, 7: ---- %, 8: ---- %. Status: 13/03/04 00:51:22 67%.

9.4 Functions

9.4.1 Math, logic signal, limit value outputs

Functions			
Mathematics		Logic sig	
No..	Mathematics	No..	Mathematics
1	<<<<<<	5	<<<<<<
2	<<<<<<	6	<<<<<<
3	<<<<<<	7	<<<<<<
4	<<<<<<	8	<<<<<<

Functions			
Logic signal		Limit value c	
No..	Logic signal	No..	Logic signal
1	0	5	0
2	0	6	0
3	0	7	0
4	0	8	0

Functions			
Limit value outputs		Timer sig	
No..	Output	No..	Output
1	0	9	0
2	0	10	0
3	0	11	0
4	0	12	0
5	0	13	0

9.4.2 Timer signal, digital control signals, operating contacts, controller, analog flag, digital flag

Functions		
Timer signals		Digital contro
No..	Timer run time	Timer output
1	00:00:00	0
2	00:00:00	0

Functions			
Digital control signals		Control cc	
No..	Output	No..	Output
1	0	5	0
2	0	6	0
3	0	7	0
4	0	8	0

Functions			
Control contact		Control	
No..	Control contact	No..	Control contact
1	0	5	0
2	0	6	0
3	0	7	0
4	0	8	0

Functions		
Controller		Analog f
Controller	Parameter set	Setpoint value
1	1	1
2	1	1

Functions			
Analog flag		Digital f	
No..	Analog flag	No..	Analog flag
1	0.0000	5	0.0000
2	0.0000	6	0.0000
3	0.0000	7	0.0000
4	0.0000	8	0.0000

Functions			
Digital flag			
No..	Digital flag	No..	Digital flag
1	0	5	0
2	0	6	0
3	0	7	0
4	0	8	0

9 Device info

9.5 Ethernet

Status	
Ethernet	
Ethernet status 1	342162
Ethernet status 2	49362
Ethernet status 3	15396
Ethernet status 4	0
Ethernet status 5	14649
Ethernet status 6	0
Ethernet status 7	16001
Ethernet status 8	0
Ethernet status 9	0

13/03/04 02:14:12 67%

Ethernet	
Ethern.info	Zähler
Ethernet-Status 1	65256
Ethernet-Status 2	0
Ethernet-Status 3	65565
Ethernet-Status 4	0
Ethernet-Status 5	14101
Ethernet-Status 6	8

30.08.16 14:00:47 Master 100%

9.6 PROFINET

PROFINET			
Status	Info	Version	Zähler
Gerätename	dicon-touch		
Status	Link Up		
IP-Adresse	0.0.0.0		
App Version			
Vergabe IP-Adres.	Manuell		

30.08.16 14:02:36 Master 100%

PROFINET			
Status	Info	Version	Zähler
Subnet	0.0.0.0		
Gateway	0.0.0.0		
DNS-1	0.0.0.0		
DNS-2	0.0.0.0		
MAC-Adresse	00-0C-D8-09-E1-6...		
MAC-Port 1	00-0C-D8-09-01-0...		
MAC-Port 2	00-0C-D8-09-01-0...		

30.08.16 14:34:39 Master 100%

PROFINET			
Status	Info	Version	Zähler
HW-Version	1		
SW-Version	46.1.1		
PROFINET-Version	085-v000 1470751996		
HOST Version	086-v000 1470751953		
CFG Version	1463638674		
CFG-UUID	783712539-248819267		
Prüf-ID	1307161500		

30.08.16 14:35:43 Master 100%

PROFINET			
Status	Info	Version	Zähler
P1 RxPacket	0		
P1 RxBroadcast	0		
P1 RxMulticast	0		
P1 RxCRCError	0		
P1 TooShortOrLong	0		
P1 TxPacket	0		

21.01.16 20:09:04 Master 100%

10.1 General information



NOTE!

The functional level is hidden per default and must be activated using the setup program.

10.1.1 Activating the functional level

The functional level is activated in the screen menu and subsequently appears in the device menu.

⇒ Chapter 12.10 "Screen", Page 112

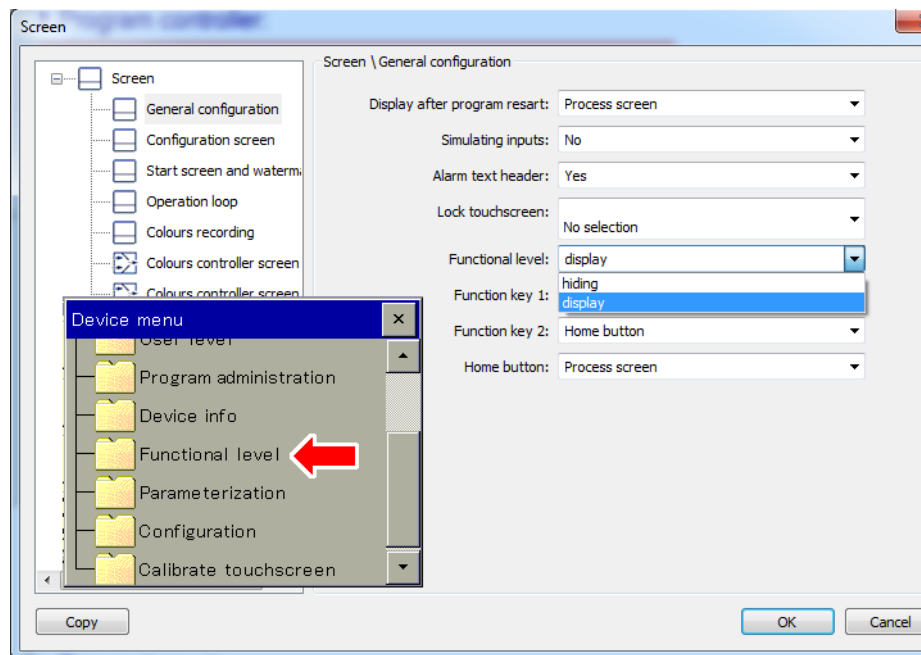

The functional level is used primarily for testing and diagnostic purposes. Analog and binary values of the outputs can be controlled manually here. This may be useful, for instance, for checking an individual piece of equipment in a plant. For maintenance and repair works, for example, the timer, ramp function, and limit value monitoring function can be operated and switching operations can be acknowledged.

Example for the timer

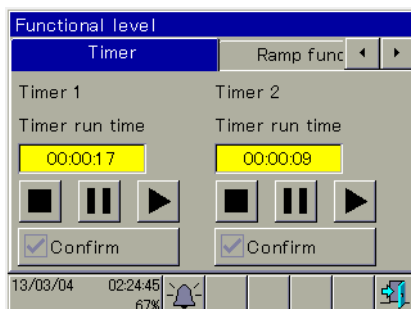

10 Functional level



NOTE!

The parameters described in this section can be entered either using the setup program or on the DICON touch. This area is for setting the parameters that relate directly to the process of adjusting the controller to suit the control process, after the plant has been started up.

You must be logged in to change the parameters.

- ⇒ Device menu section > Login
- ⇒ Chapter 7 "User level (Log-In)", Page 47

Setup dialog box

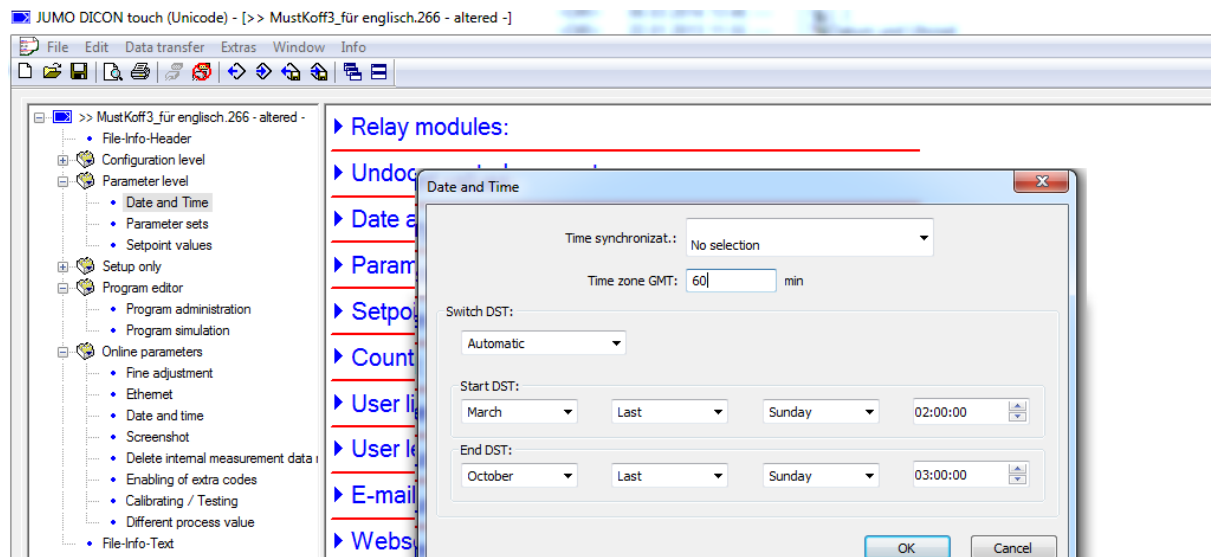

11.1 Date and time

The following table shows the time settings for the device.

Parameter	Setting	Description
Current date	2011-01-01 2083-12-31	Enter the date here.
Current time	00:00:00 23:59:59	Enter the time here.

11.2 Daylight saving time

The following table shows the settings for daylight saving time.

Parameter	Setting	Description
Time synchronizat.	No function Digital selector	A digital signal can be selected here to synchronize the time.
Switch DST	automatic inactive	Enables you to set the time to change automatically.

11 Parameterization

Parameter	Setting	Description
Start DST	Month: March Week: last week Day: Sunday Time: 02:00:00	The switchover takes place at this time.
End DST	Month: October Week: last week Day: Sunday Time: 03:00:00	The switchover takes place at this time.

11.3 Controller/parameter blocks

Setup dialog box

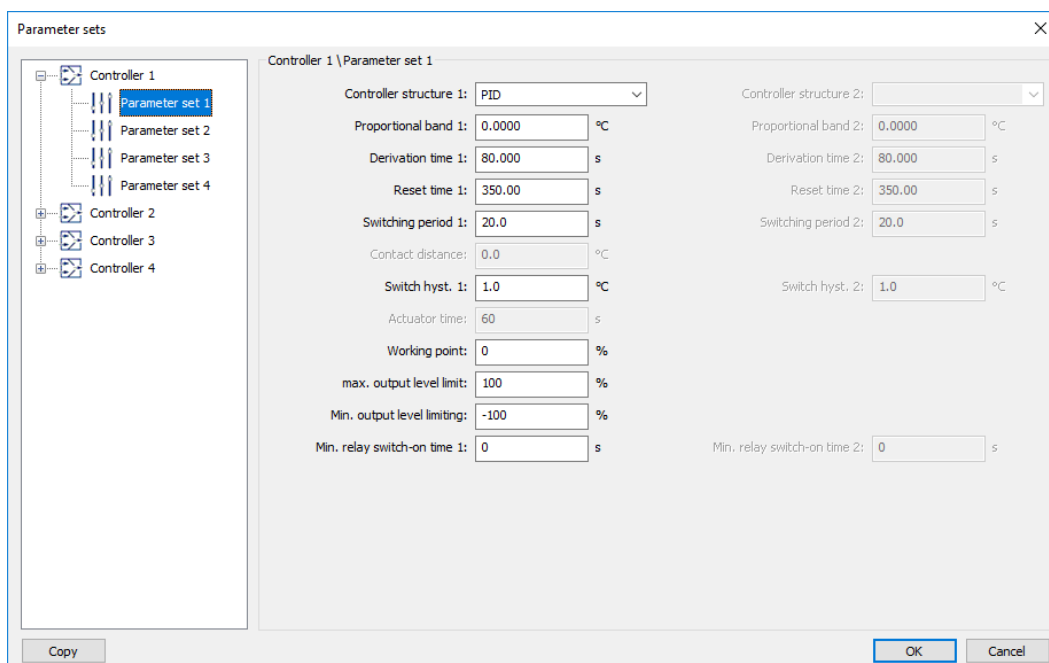

The following table shows the parameters in a parameter block. These parameters are also available for the other three parameter blocks. Four parameter blocks can be defined for each of the two control channels. Switching the parameter blocks is performed separately for each control channel via two digital signals.

Depending on the controller type configured, certain parameters may be omitted or ineffective. Parameters that appear in pairs such as Proportional band 1 and 2 refer to the first and second controller outputs (for instance, with three-state controllers).

The parameter blocks are assigned to both controllers in the configuration level.

⇒ Operating manual Chapter 12.6.2 "Controller inputs", Page 82

11 Parameterization

Parameter	Setting	Description
Proportional band 1 (Xp1)	0 to 9999	Value for the proportional band The controller structure has no effect if $X_p = 0$ (behavior identical to limit value monitoring function)! For a continuous controller, X_p must be > 0 .
Proportional band 2 (Xp2)	0 to 9999	
Derivative time 1 (Tv1)	0 to 80 to 9999 s	The derivative time influences the differential component (D component) of the controller output signal. The greater the derivative time, the more effect the D component has.
Derivative time 2 (Tv2)	0 to 80 to 9999 s	
Reset time 1 (Tn1)	0 to 350 to 9999 s	The reset time influences the integral component (I component) of the controller output signal. The greater the reset time, the less effect the I component has.
Reset time 2 (Tn2)	0 to 350 to 9999 s	
Cycle time 1 (Cy1)	0 to 20 to 999.9 s	When using a switched output, the cycle time should be chosen so that the energy supply to the process is as continuous as possible, and the switching elements are not overloaded.
Cycle time 2 (Cy2)	0 to 20 to 999.9 s	
Contact spacing (Xsh)	0 to 999.9	Spacing between the two control contacts for a three-state controller, three-step controller, and continuous controller with integrated position controller
Switching differential 1 (Xd1)	0 to 1 to 999.9	Hysteresis for a switching controller with proportional band $X_p = 0$
Switching differential 2 (Xd2)	0 to 1 to 999.9	
Actuator time (TT)	5 to 60 to 3000 s	Control valve runtime range used for a three-step controller and continuous controller with integrated position controller
Working point (Y0)	-100 to 0 to +100 %	Working point correction for a P or PD controller (correction value for the output level) If the actual value (x) has reached the setpoint value (w), the output level (y) corresponds to the working point (Y0).
Max. output level limit (Y1)	0 to 100 %	Admissible maximum output level (only effective if $X_p > 0$)

11 Parameterization

Parameter	Setting	Description
Min. output level limit (Y2)	-100 to +100 %	Admissible minimum output level (only effective if $X_p > 0$)
Minimum relay ON period 1 (Tk1)	0 to 60 s	Limits the switching frequencies for switched outputs
Minimum relay ON period 2 (Tk2)	0 to 60 s	

Transmission behavior

The transmission behavior (controller structure) is determined by the configuration of the parameters for the proportion band (P component), derivative time (D component), and reset time (I component).

Two-state controller

This controller has a switched output and can be parameterized with P, PI, PD, or PID transmission behavior. The proportional band X_p must be greater than 0 for the controller structure to take effect.

If $X_p = 0$, the behavior corresponds to the function of limit value monitoring with switching differential X_{d1} (working point $Y_0 = 0\%$):

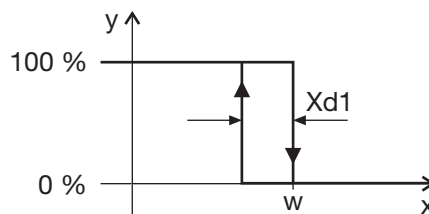

Influence of working point Y_0 on the switching behavior

$Y_0 = 0\%$

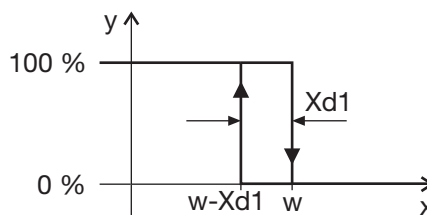

$Y_0 = 100\%$

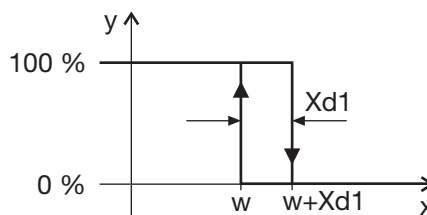

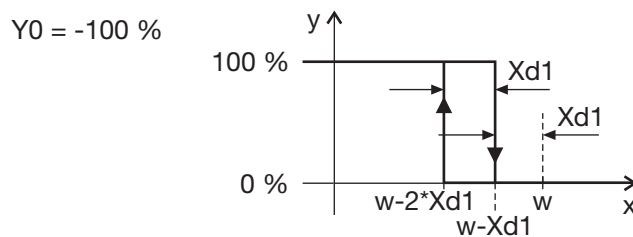

Three-state controller

This controller has two outputs, which can be configured as continuous (analog output) or switched (digital output). In both cases, the controller can be parameterized with P, PI, PD, or PID transmission behavior. The proportional bands X_{p1} and X_{p2} must be greater than 0 for the controller structure to take effect.

If $X_{p1} = 0$ and $X_{p2} = 0$, the behavior corresponds to the function of limit value monitoring with switching differential X_{d1} and X_{d2} , and contact spacing X_{sh} (working point $Y_0 = 0\%$):

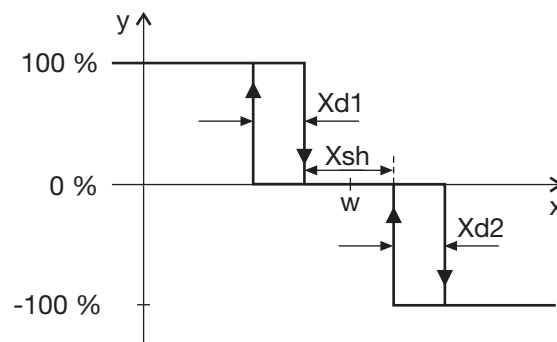

Three-step controller

This controller has two switched outputs and can be parameterized with PI or PID transmission behavior. The proportional band X_p must be greater than 0 for the controller structure to take effect.

The three-step controller is used for actuator drives with three switching statuses (actuator open, closed, hold). If output level feedback is available, the active output is deactivated when the output level limits are reached.

Continuous controller

This controller has a continuous output (analog output) and can be parameterized with P, PI, PD, or PID transmission behavior. The proportional band X_p must be greater than 0 for the controller structure to take effect (the setting $X_p = 0$ is normally not used in practice).

Position controller

This controller is a continuous controller with integrated position controller and two switched outputs (digital outputs) with PI or PID transmission behavior.

The position controller is used for actuator drives with three switching statuses (actuator open, closed, hold). Output level feedback is required.

11 Parameterization

11.4 Setpoint values

4 switchable setpoint values are assigned to a fixed-setpoint controller and can be entered on the device or in the setup program.

The following table shows the setpoint changeover for fixed-setpoint controllers using two digital signals that can be set in Chapter 12.6.7 "Controller setpoint values", Page 97.

For program controllers

⇒ Chapter 8.1 "Entering program profiles", Page 49

Type	Signal 2 (Bit 1) setpoint changeover	Signal 1 (Bit 0) setpoint changeover	Setpoint value, Controller 1	Setpoint value, Controller 2
Fixed-setpoint controller	0	0	Setpoint 1	Setpoint 1
	0	1	Setpoint value 2	Setpoint value 2
	1	0	Setpoint value 3	Setpoint value 3
	1	1	Setpoint value 4	Setpoint value 4
Program controller			W1 and W2 are predefined by the program generator	

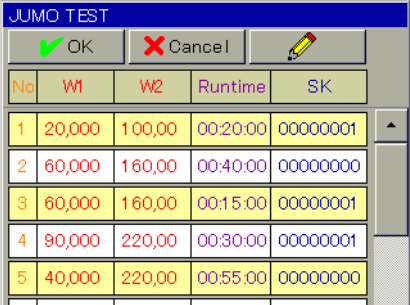

No	W1	W2	Runtime	SK
1	20,000	100,00	00:20:00	00000001
2	60,000	160,00	00:40:00	00000000
3	60,000	160,00	00:15:00	00000001
4	80,000	220,00	00:30:00	00000001
5	40,000	220,00	00:55:00	00000000

11.4.1 Entering the values on the device

The setpoint values are entered in the parameter level.

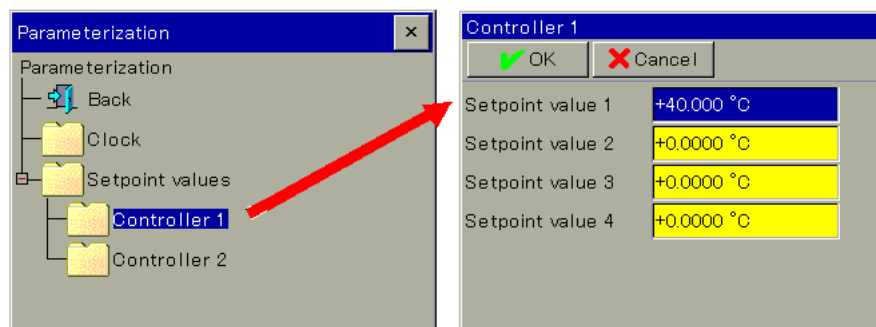

11.4.2 Entering the values using the setup program

The setpoint values are entered in the parameter level setup dialog.

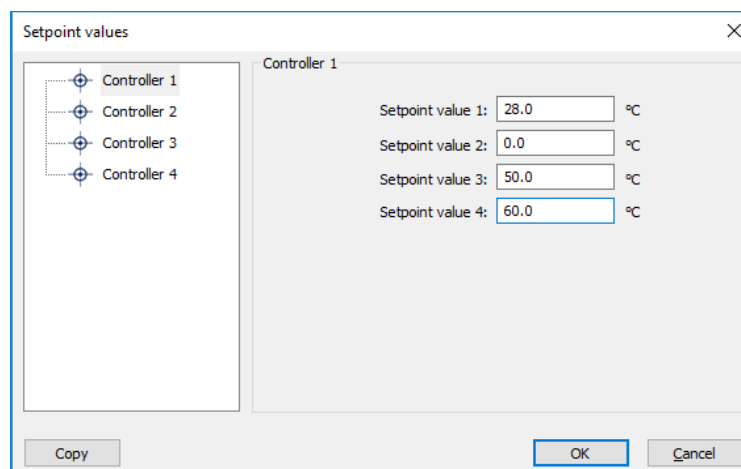

11 Parameterization



NOTE!

The parameters described in this section can be edited using either the setup program or DICON touch. This area is for making settings (for example, measured value recording, outputs, Ethernet, and controller type) that are required immediately for startup in a specific plant and that therefore seldom need to be changed.

Depending on the configuration, signals which are not in use are hidden. Functions available in both selectors are highlighted in a specific color.

12.1 Analog selector

- Analog selection
- No selection
- Analog inputs
- External analog input
- Mathematics
- Controller
- Setpoint values
- Program setpoint val.
- Section end values
- Flag
- Service
- Sampling periode

The analog selector contains all analog signals available in the configuration dialogs of a tree structure in the DICON touch.

All analog signals are shown in the following table. The entry in the "Type" column indicates the source of the signal:

- Internal: Internal signal for the DICON touch (including signals from the analog inputs)
- External: External input, for example, one that can be transmitted via an interface

Category	Signal	Type	Description
No function			No signal selected
Analog inputs	Analog input (IN8) Analog input (IN9) Analog input (IN10) Analog input (IN11)	Internal	Measured values of analog inputs 1 to 4 ⇒ Chapter 12.5 Analog inputs IN8, IN9, IN10, IN11 Page 75
External analog inputs	External analog inputs 1 to 8	External	Analog value of the external analog input 1 to 8 ⇒ Chapter 12.18 External analog inputs Page 143
Mathematics	Math 1 to 8	Internal	Result of the math function 1 to 8 ⇒ Chapter 12.15 Math/logic Page 138
Controller 1 to 4	Actual value of controller 1 to 4 Setpoint value of controller 1 to 4 Control difference of controller 1 to 4 Output level display of controller 1 to 4 Output 1 of controller 1 to 4 Output 2 of controller 1 to 4 Cascade output level of controller 1 to 4	Internal	⇒ Chapter 12.6.1 Controller configuration Page 79
Setpoint values	Ramp end value of controller 1 to 4 Setpoint specification of controller 1 to 4 Setpoint value 1 to 4 of controller 1 to 4	Internal	Setpoint value for control channel 1 to 4 as fixed-setpoint controller ⇒ Chapter 12.6.7 Controller setpoint values Page 97

12 Configuration

Category	Signal	Type	Description
Program setpoint values	Program setpoint 1 to 4	Internal	Setpoint value for control channel 1 to 4 as program controller ⇒ Chapter 12.12 Program controller Page 123
Section end values	Section end value 1 to 4	Internal	
Flag	Flag 1 to 8	Internal	Analog value of the analog flag ⇒ Chapter 12.16 Flags/service Page 140
Service	Terminal temperature	Internal	Measured value (internal Pt100)
Sampling period	Sampling rate	Internal	Measured value of sampling rate

12.2 Digital selector

- Digital selector
- No selection
- Controller
- Digital inputs
- External digital inputs
- Digital control signals
- Limit value outputs
- Timer
- Logic output
- Ramp signals
- Program controller
- Control contacts

The digital selector contains all digital signals that are available in the configuration dialogs of a tree structure in the DICON touch.

All the digital signals are shown in the following table. The entry in the "Type" column indicates the source of the signal:

- Internal: Internal signal for the DICON touch (including signals from the digital inputs)
- External: External value is transferred via the interface, for example

Category	Signal	Type	Description
No function			No signal selected
Controller 1 to 4	1st output of controller 1 to 4 2nd output of controller 1 to 4 Autotuning of controller 1 to 4 Manual mode of controller 1 to 4 Controller 1 to 4 Off Control loop alarm 1 to 4 Output level alarm 1 to 4	Internal	Switched outputs of controller 1 to 4 Logic level "0", function inactive Logic level "1", function active ⇒ Chapter 12.6.1 Controller configuration Page 79
Digital inputs	Digital input 1 to 7	Internal	Logic level for connected potential-free contacts 1 to 7 ⇒ Chapter 12.4 Digital inputs IN1 to 7 Page 74
External digital inputs	External digital input 1 to 8	External	Logic level for the external digital inputs 1 to 8 ⇒ Chapter 12.17 External digital inputs Page 142

12 Configuration

Category	Signal	Type	Description
Digital control signals	Digital control signals 1 to 8	Internal	Logic level for the defined digital control signals 1 to 8 ⇒ Chapter 12.14 Digital controller signals Page 135
Limit value outputs	Limit value output 1 to 16	Internal	Logic level of the limit value monitoring function 1 to 16 ⇒ Chapter 12.9 Limit value monitoring function Page 106
Timer	Timer output 1 to 4 Timer end signal 1 to 4 Timer tolerance band 1 to 4 Timer stop signal 1 to 4	Internal	Logic level of the output signals of timer 1 to 4 Logic level "0", function inactive Logic level "1", function active ⇒ Chapter 12.13 Timer or week-time switch Page 132
Logic output	Logic output 1 to 8	Internal	Result of logic function 1 to 8 ⇒ Chapter 12.15 Math/logic Page 138
Ramp signals	Ramp end signal 1 Tolerance band signal 1 Ramp end signal 2 Tolerance band signal 2	Internal	Logic level "0", function inactive Logic level "1", function active ⇒ Chapter 12.6.8 Ramp function Page 99
Program controller	Program end signal Program auto signal Tolerance band signal Program stop signal	Internal	Logic level "0", function inactive Logic level "1", function active ⇒ Chapter 12.12 Program controller Page 123
Control contacts	Operating contact 1 to 16	Internal	Logic level of the operating contacts, for example in automatic mode. ⇒ Chapter 8.1.5 Operating contacts Page 51
Flag	Digital flags 1 to 8	Internal	Logic level of the digital flag ⇒ Chapter 12.16 Flags/service Page 140
Service	Service signal	Internal	Logic level of the service signal ⇒ Chapter 12.16 Flags/service Page 140
Function buttons	Function key 1 to 2	Internal	Logic level of the 2 function buttons ⇒ Chapter 5.1 Display and operating concept Page 37

12 Configuration

Category	Signal	Type	Description
Analog input alarm	MinAlarm IN8 MaxAlarm IN8 MinAlarm IN9 MaxAlarm IN9 MinAlarm IN10 MaxAlarm IN10 MinAlarm IN11 MaxAlarm IN11	Internal	Min. and max. alarm signals of the analog inputs 1 to 4 ⇒ Chapter 12.5 Analog inputs IN8, IN9, IN10, IN11 Page 75
Ext. analog input alarm	MinAlarm Ext. AI 1 MaxAlarm Ext. AI 1 MinAlarm Ext. AI 2 MaxAlarm Ext. AI 2 MinAlarm Ext. AI 3 MaxAlarm Ext. AI 3 MinAlarm Ext. AI 4 MaxAlarm Ext. AI 4 MinAlarm Ext. AI 5 MaxAlarm Ext. AI 5 MinAlarm Ext. AI 6 MaxAlarm Ext. AI 6 MinAlarm Ext. AI 7 MaxAlarm Ext. AI 7 MinAlarm Ext. AI 8 MaxAlarm Ext. AI 8	Internal	Min. and max. alarm signals of the ext. analog inputs 1 to 8 ⇒ Chapter 12.18 External analog inputs Page 143
Math alarm	MinAlarm Math 1 MaxAlarm Math 1 MinAlarm Math 2 MaxAlarm Math 2 MinAlarm Math 3 MaxAlarm Math 3 MinAlarm Math 4 MaxAlarm Math 4 MinAlarm Math 5 MaxAlarm Math 5 MinAlarm Math 6 MaxAlarm Math 6 MinAlarm Math 7 MaxAlarm Math 7 MinAlarm Math 8 MaxAlarm Math 8	Internal	⇒ Chapter 12.15 Math/logic Page 138
Digital alarms	Digital alarm 1 to 7	Internal	Alarms for connected potential-free contacts 1 to 7 ⇒ Chapter 12.4 Digital inputs IN1 to 7 Page 74

12 Configuration

Category	Signal	Type	Description
Ext. digital alarms	Ext. digital alarm 1 to 8	External	Alarms for ext. digital inputs ⇒ Chapter 12.17 External digital inputs Page 142
Digital control alarms	Digital control alarm 1 to 8	Internal	Alarms for the defined digital control signals 1 to 8 ⇒ Chapter 12.14 Digital controller signals Page 135
Limit value alarms	Limit value alarm 1 to 16	Internal	Alarms for the limit value monitoring function 1 to 16 ⇒ Chapter 12.9 Limit value monitoring function Page 106
Logic alarms	Logic alarm 1 to 8	Internal	Alarms for logic function 1 to 8 ⇒ Chapter 12.15 Math/logic Page 138
Alarm signals and internal signals	Collective alarm	Internal	Collective alarm of the controller is active, starting with the collective alarm event to the end of the alarm (as long as the red alarm line flashes)
	Collective alarm acknowledged		Is active, starting with the collective alarm event to the acknowledgment of the alarm (as long as the red bell is illuminated)
	Memory alarm		Memory alarm limit exceeded ⇒ Chapter 12.3 Basic settings Page 72
	Malfunction		
	Fieldbus error		Is active if PROFIBUS or PROFINET report an error
	Battery empty		Buffer battery must be replaced by JUMO Service
	Battery pre-alarm		Buffer battery voltage under 2.6 V
	Login		Logic level "0", user not logged in Logic level "1", user logged in
	USB inserted		Logic level "0", USB not inserted Logic level "1", USB inserted
	Temp. in Fahrenheit		Logic level "0", temp. not °F Logic level "1", temp. in °F
	Inside temperature too high		Logic level "0", inside temperature not too high Logic level "1", inside temperature too high

12 Configuration

12.3 Basic settings

These settings are applicable for the entire device.

Setup dialog box

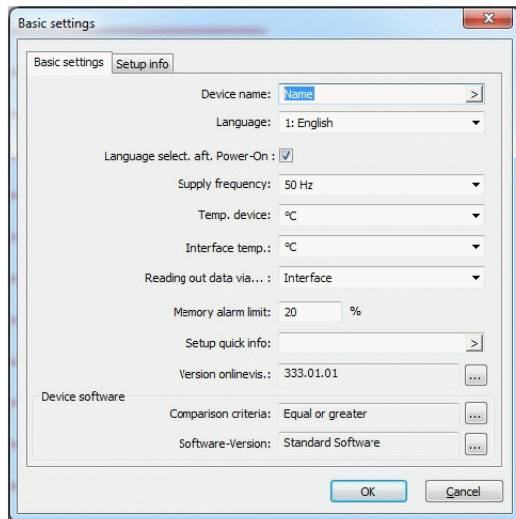

1 on device:

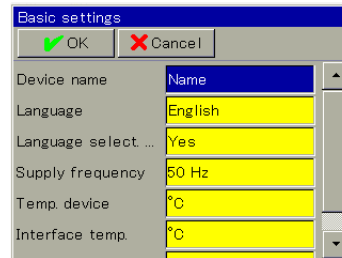

Parameters

Parameter	Selection/settings	Description
Device name	Name	20 characters of editable text
Language	1.German 2.English	The device can save up to 2 languages. Additional languages can only be managed using the setup program: EDIT > SETUP ONLY > COUNTRY SETTINGS. ⇒ Chapter 13.4 "Country settings", page 155
Language select. aft. Power-On		
&	Not selected (empty); no Selected (); yes	The device starts without language selection The language selection appears
Supply frequency	50 Hz 60 Hz	
Temp. device	Deg. Celsius Deg. Fahrenheit	Temperature unit for displaying the temperature in the device
Interface temp.	Deg. Celsius Deg. Fahrenheit	Temperature unit for displaying the temperature values using the interface
Reading out data via: (only setup)	Interface USB	Save recording data using the interface Save recording data on the stick ⇒ Chapter 12.11 "Recording 1, 2", page 120
Memory alarm limit (in the device) 	0 to 20 % to 100 %	If the available recording data memory in the device is less than this threshold, an alarm will be issued.

Parameter	Selection/settings	Description
Setup quick info	-	Any text may be transferred to the device during the data transfer.
Version onlinevis. (only setup)	Standard online visualization	Software version of the webserver software
	No online visualization	
	Example 333.01.01-13	If relevant, additional versions are listed that can be selected in the version library and can be specifically selected for the software update.
Comparison criteria (setup only)	Compatible Equal or greater	Setup program<->device software
Software-Version (only setup)	Standard Software	The device software version is available here

Language select. aft. Power-On

Selecting "yes" for this setting means that a language selection prompt appears following "power on", which gives the user the opportunity to select their preferred language.

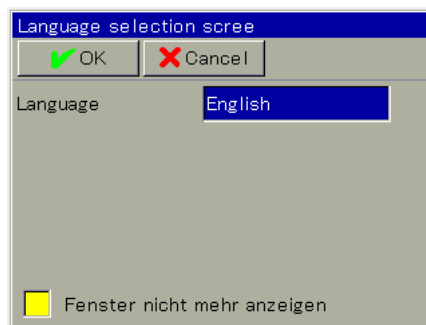

Memory alarm limit

If, for example, the available memory is less than 20 % when recording data, an entry will be made in the alarm list. This enables the user to retrieve the recording data using the USB flash drive or the interface (as configured).

The value indicating the available memory only returns to 100 % once the data has been retrieved. If the remaining 20 % has been used up, the oldest recorded data is overwritten and replaced with the new data. In this case, there will be a gap in the recording.

12 Configuration



12.4 Digital inputs IN1 to 7

A maximum of seven digital inputs (IN 1 to 7) are available for connecting to potential-free contacts with a common ground.

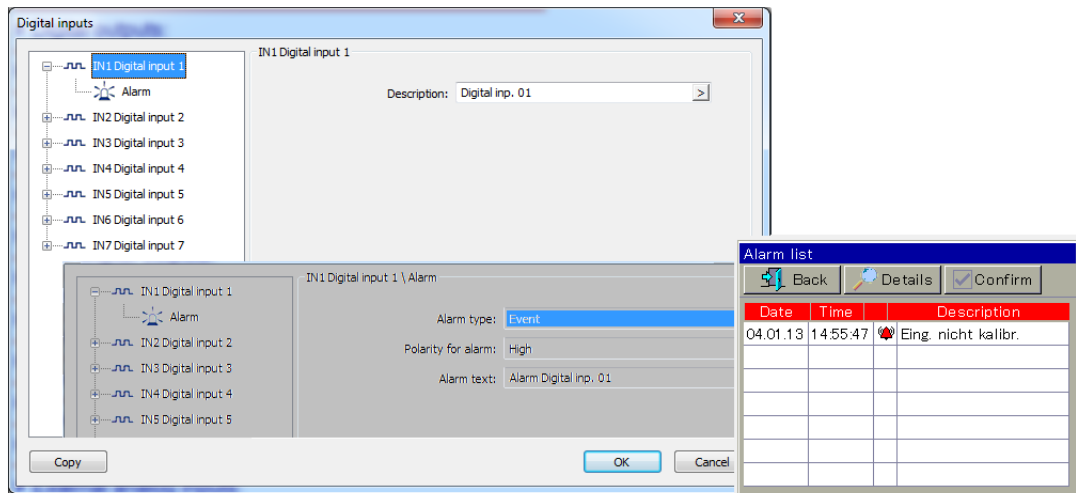
Setup dialog box



Parameters

Parameter	Selection/settings	Description
Channel description	Digital input 01	(15 characters) of editable text that indicates, for example, what the signal will be used for.
Alarm type	Off	Alarm switched off.
	Alarm	A message will be entered in the alarm list depending on the signal level that has been set.
	Event	A message will be entered in the event list depending on the signal level that has been set.
Polarity for alarm  (setup only)	Signal level that triggers an alarm or an event. High Low	Contact closed: high (logic "1") Contact open: low (logic "0")
Alarm text (only setup) 	Alarm Digital inp. 01	20 characters of editable text which is entered into the alarm or event list.

Alarm active at

An alarm is only displayed for as long as the configured signal level (closed contact) is present. If the contact is opened, the alarm entry disappears automatically.

Alarm text

The setup program is required to view and edit the texts.

12.5 Analog inputs IN8, IN9, IN10, IN11

The two analog inputs IN8 and IN9 are installed per default as universal measurement inputs for RTD temperature probes, thermocouples, resistance transmitters/resistance potentiometers, and standard signals. Two additional analog inputs, IN10 and IN11, can be retrofitted.



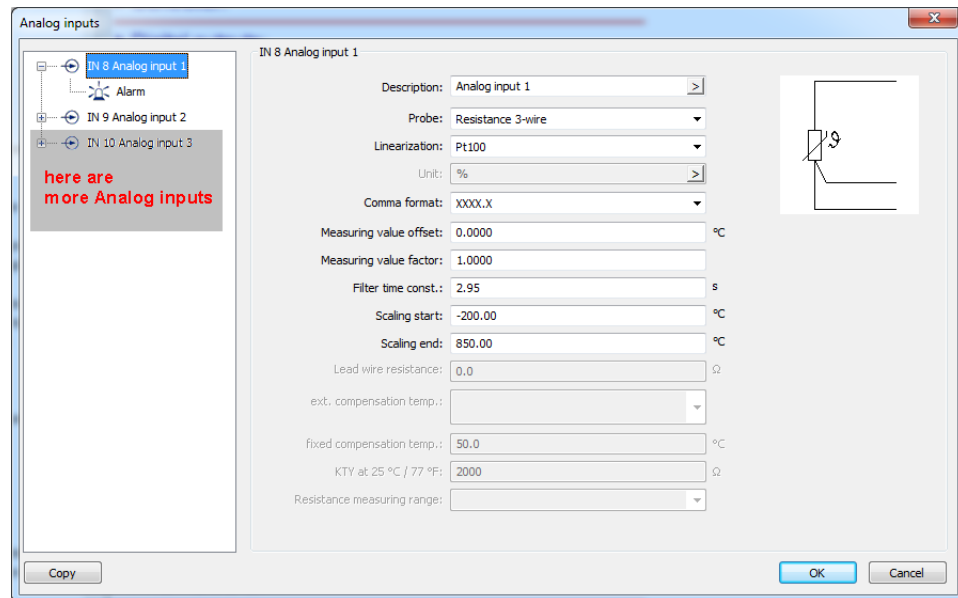

Setup dialog box



Parameters

Parameter	Selection/settings	Description
Channel description	Analog input IN8, IN9, IN10, IN11	(15 characters) of editable text
Probe	Selection of measuring probe for the relevant analog input	
	No function	No sensor selected
	Resistance 3-wire	RTD temperature probe in three-wire circuit
	Resistance 2-wire	RTD temperature probe in two-wire circuit
	Int. thermocouple	Internal thermocouple Cold junction temperature
	Ext. thermocouple	External thermocouple Cold junction temperature
	Thermocouple constant	Thermocouple constant Cold junction temperature
	Resistance transmitter	Resistance transmitter
	0 to 20 mA	Standard signal
	0 to 10 V	Standard signal
	0 to 1 V	Standard signal
	0 to 100 mV	Standard signal
	4 to 20 mA	Standard signal
	2 to 10 V	Standard signal

12 Configuration

Parameter	Selection/settings	Description
Measuring value offset 	-100 to 0 to +100	Parallel shift of all measured values
Measuring value factor 	1.000	Slope
Filter time const. 	0 to 0.6 to 100	Time constant for adjusting the digital input filter (0 s = filter off)
Scaling start 	Default setting depends on sensor and linearization.	
	-99999 to +99999	Start value of display range for standard signals
Scaling end 	Default setting depends on sensor and linearization.	
	-99999 to +99999	End value of display range for standard signals
Lead wire resistance	0 Ω	The line resistance for a two-wire circuit is entered here.
ext. compensation temp.	No selection Analog selector	- The measurand used to acquire the cold junction temperature is set here.
fixed compensation temp.	0 to 50 to 100 °C	If the cold junction has a fixed temperature, this is entered here.
KTY at 25 °C/77 °F	0 to 2000 to 10000 Ω	Basic resistance of a KTY probe at 20 °C
Resistance measuring range	0 to 400 Ω	These measuring ranges are available for a resistance measurement with customer-specific linearization
	0 to 4000 Ω	

Linearization

Linearization is dependent upon the probe that is connected (measuring probe).

The predefined linearizations can be supplemented with **customer-specific linearization**.

⇒ Setup program:

SETUP ONLY > CUSTOMER-SPECIFIC LINEARIZATION

Measuring value offset, measuring value factor

The value for the measuring value offset ensures a parallel shift of all measured values; the value for the measuring value factor influences the slope of the values displayed.

Filter time const.

The filter time constant is used to adjust the digital input filter (2nd order filter). If the input signal changes suddenly, approx. 26 % of the change is acquired following a period that corresponds to the filter time constant (2× filter time constant: approx. 59 %; 5× filter time constant: approx. 96 %). A large filter time constant means: high attenuation of interference signals, slow reaction of the actual value display, low limit frequency (low-pass filter).

Scaling start, scaling end

The maximum measuring range limits are displayed here, depending on the probe selected and the linearization. These limits only affect the recording. If, for example, the scaling end for a Pt100 is reduced from 850 °C to 400 °C, the recording only displays values up to 400 °C.

12 Configuration

Lead wire resistance

When connecting an RTD probe in a two-wire circuit, longer lines may lead to measuring errors. This value is used to compensate the resistance of the probe line and depends on the line length. Enter the ohmic resistance of the probe line here to achieve the best possible temperature measurement.

12.5.1 Alarms

A limit value monitoring function with one or two alarms and various alarm types can be activated for each analog input. In addition, this function is required in order to trigger the collective alarm of the controller module in the event of deviation above or below the measuring range (out of range).

This limit value monitoring function is available in addition to the functions described in Chapter 12.9 "Limit value monitoring function", page 106 and is independent of these functions.

Setup dialog box

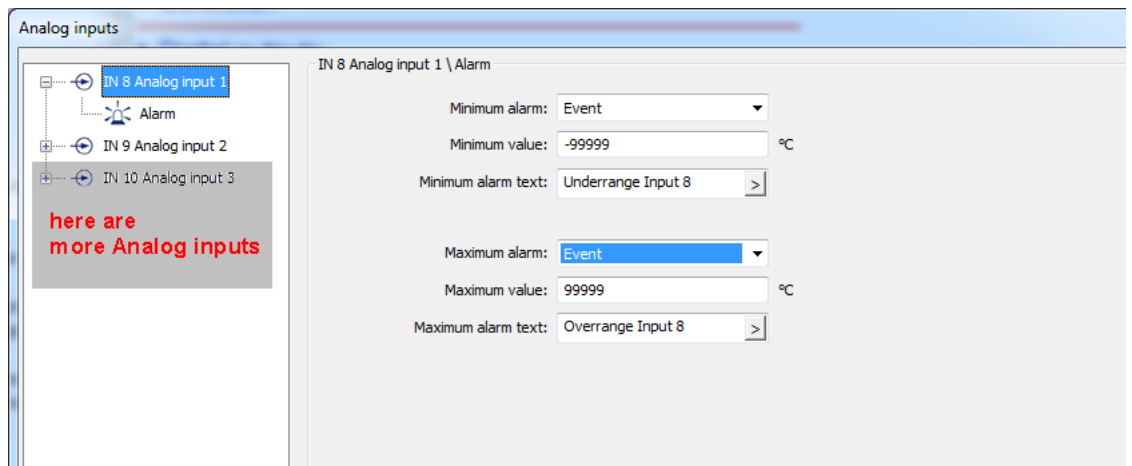

Parameters

Parameter	Selection/settings	Description
IN 8 Analog input 1, IN9 Analog input 2		
Minimum alarm	Off Alarm Event	Monitoring is not active. Alarm results in an entry in the alarm list. Alarm results in an entry in the event list.
Minimum value	-99999 to 0 to +99999	Limit value at which an alarm is issued.
Minimum alarm text	Underrange AI1	Text which is entered into the alarm or event list if the value is exceeded.
Maximum alarm	Off Alarm Event	Monitoring is not active. Alarm results in an entry in the alarm list. Alarm results in an entry in the event list.
Maximum value	-99999 to 0 to +99999	Limit value at which an alarm is issued.
Maximum alarm text	Ovrange AI1	Text which is entered into the alarm or event list if the value is exceeded.

12.6 Controller 1 to 4

A maximum of 4 controllers (control channels) are available. The parameters listed here can be configured independently of each other for controllers 1 to 4.

12.6.1 Controller configuration

The controller type, the control direction, the output level for changeover to manual mode and for deviation above or below the measuring range, as well as the output level standardization and the deadband width are specified here.

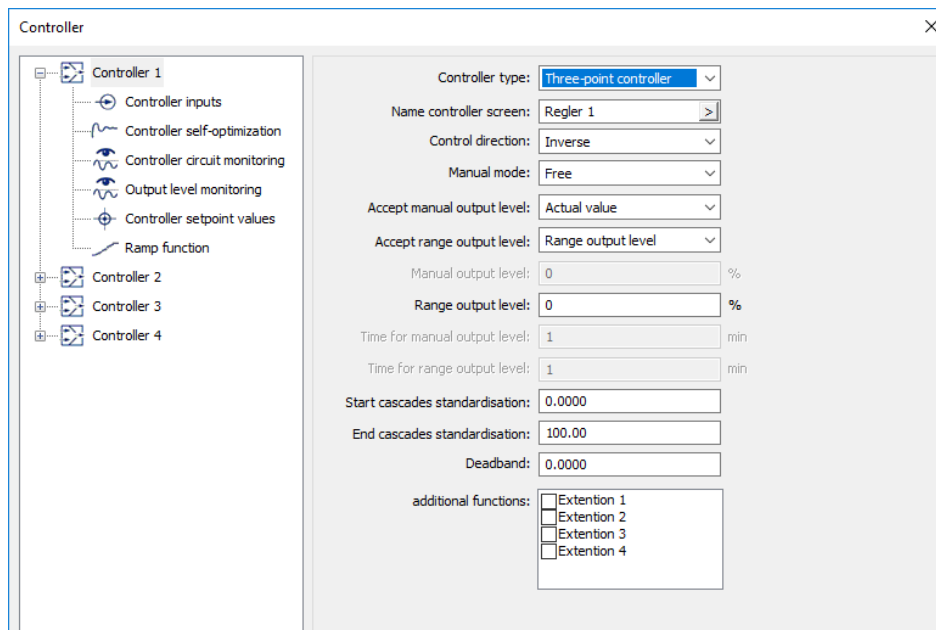

Setup dialog box



Parameters

Parameter	Selection/settings ¹	Description
Controller 1 to 4		
Controller type	Off Two-state controller Three-state controller Three-step controller Continuous controller Position controller	Control channel switched off (default setting for Controller 2) Controller with a switched output (default setting for Controller 1) Controller with two continuous or switched outputs (for example, for heating/cooling) Controller with two switched outputs (for motor actuator) Controller with a continuous output (analog signal) Continuous controller with integrated position controller (for motor actuator)
Control direction 	Direct (2)	The controller output level is positive if the actual value is greater than the setpoint value (cooling).
	Inverse (1)	The controller output level is positive if the actual value is smaller than the setpoint value (heating).

12 Configuration

Parameter	Selection/settings ¹	Description
Manual mode 	Enabled	Manual mode possible on the device
	Disabled	Manual mode disabled
Y in manual mode		Defines the output level (%) that the controller should adopt after switching to manual mode.
	Y manual mode	The value set below for Y manual mode is adopted.
	Current value	The current controller output level before switching to manual mode is adopted.
	Average value	The average value calculated using the set time below is adopted.
Y with error		Defines the output level (in %) that the controller should display, if one of the analog values relevant for the controller is invalid (incorrect actual value, setpoint value, output level feedback, etc).
	Y replacement value	The Y replacement value set below is adopted.
	Current value	The current output level before deviation above or below the measuring range is adopted.
	Average value	The average value calculated using the set time below is adopted.
Y manual mode	0 to 100 %	
Y replacement value	0 to 100 %	
Time for manual average value	1 to 3600 min	Time for averaging of values when average value is set for "Y in manual mode"
Time for replacement average value	1 to 3600 min	Time for averaging of values when average value is set for "Y with error"
Start of cascade standardization	0 to 100 %	The output level can be standardized here (only for cascade controllers).
End of cascade standardization	0 to 100 %	
Deadband (neutral zone) 	0.00 to 100 %	Output level movements within the deadband are suppressed, for example in the case of noisy signals. The deadband is only effective for controller structures with an I-component.
Additional functions Not selected (empty)		
(setup only)	<input type="checkbox"/> Extension 1	Reserved functions for service
	<input type="checkbox"/> Extension 2	
	<input type="checkbox"/> Extension 3	
	<input type="checkbox"/> Extension 4	

¹ Bold: default setting

Control direction

Is set to inverse (1) per default for heating mode.

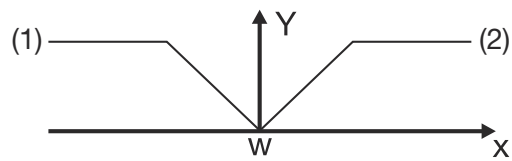

Manual mode

If the setting is set to disabled, manual mode is no longer possible on the device. The button for manual mode is grayed out.

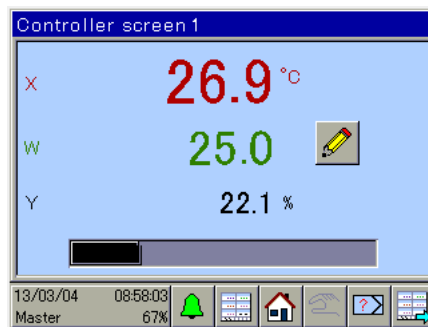

Deadband

Default is 0, i.e. no distance between heating and cooling contact.

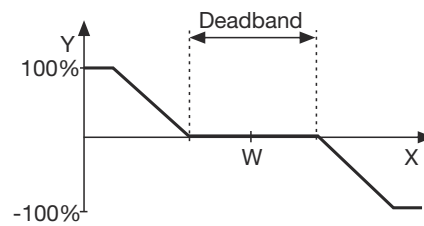

12 Configuration

12.6.2 Controller inputs

This menu is used to configure the input signals of the controller – incl. the signals for switching off the controller and for parameter block changeover – and the parameters for manual mode.

Setup dialog box

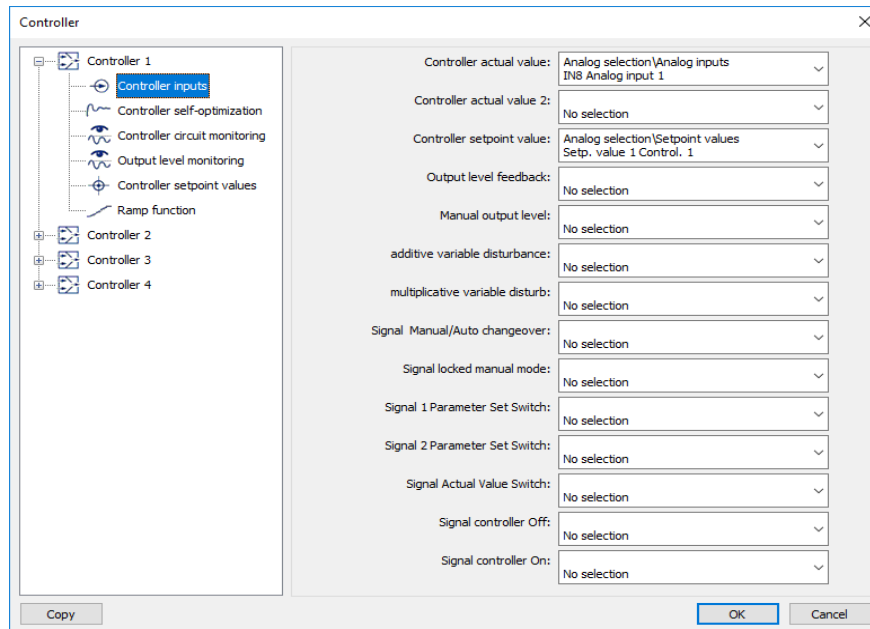

Parameters

Parameter	Selection/settings	Description
Controller 1, Controller 2		
Controller actual value	IN8 analog input 1 Analog selector	Analog signal for actual value
Controller setpoint value	Setpoint specification for Controller 1 Analog selector	Analog signal for setpoint value
Output level feedback	No selection	Analog signal for output level feedback
Manual output level	Analog selector	Analog signal for manual output level
additive variable disturbance		Analog signal for additive variable disturbance
multiplicative variable disturb.		Analog signal for multiplicative variable disturbance

Parameter	Selection/settings	Description
Signal Manual/Auto changeover	No selection	This signal switches between manual mode and automatic mode.
Signal Manual mode locking	Digital selector	This signal locks manual mode
Signal 1 parameter block switching		The parameter blocks entered in Chapter 11.3 "Controller/parameter blocks", page 60 are switched using both these signals.
Signal 2 parameter block switching		
Signal for actual value switching		The analog inputs (actual value inputs) are switched using this digital signal.
Controller off signal		The controller can be switched to On or Off using this signal.
Controller on signal		

Actual value switching

Provided that no signal has been selected for switching the actual value, the actual values from the analog selector that were set during the controller configuration are active. If, however, a signal is set for switching the actual value, then with the High signal level (logic level 1) the system switches to the actual values outlined in red.

Controller 1 is then linked to IN9 (analog input 2) and Controller 2 to IN10 (analog input 3).

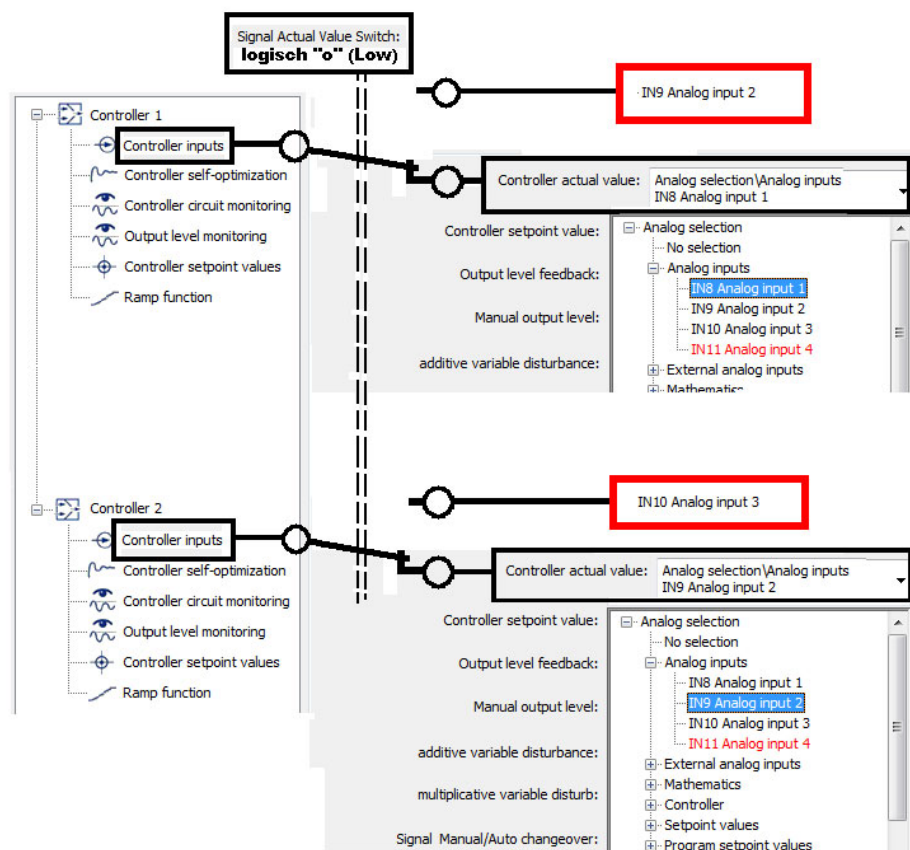

12 Configuration

12.6.3 Controller self-optimization

Autotuning, also known as self-optimization (abbreviation: SO), determines the optimum controller parameters for a PI or PID controller.

Setup dialog box

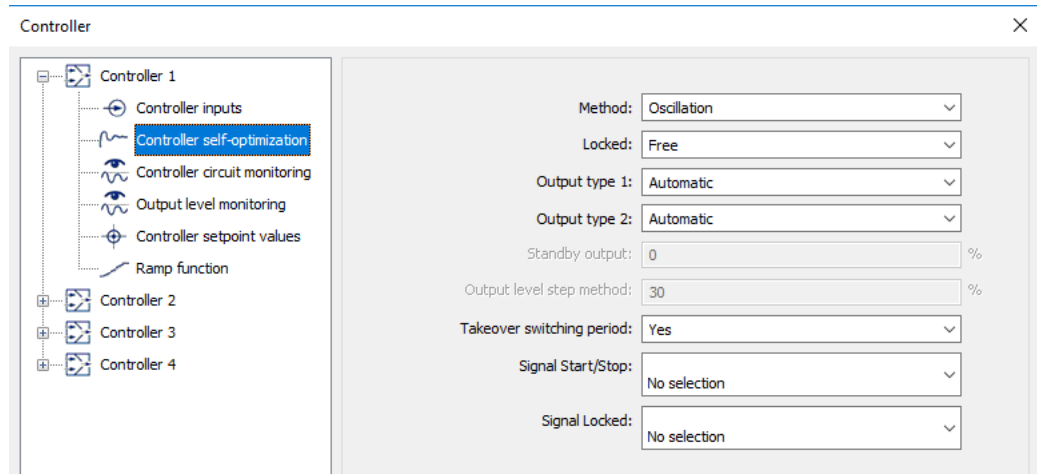

Parameters

Parameter	Selection/settings ¹	Description
Method 	Oscillation Step response	Oscillation method Step response method
Locking	Enabled Disabled	Autotuning can be started on the device Autotuning is disabled
Output type 1, 2 	Automatic Relay Solid state, logic Analog	Output level is recognized automatically. Output level is displayed using the relay... ... using the solid state relay or digital signal... ... using the analog output.
Standby output	0 to 100 %	
Output level for step method	0 to 30 to 100 %	Output level step for step response method
Application of switching period (Cy)	Yes No	Cy is determined during autotuning Cy is not determined
Signal start/stop	No selection Digital selector	Start/stop signal for autotuning
Signal Locked	No selection Digital selector	Signal for locking autotuning

¹ Bold: default setting

Method

The standard method is the oscillation method, whereas the step response method is used specifically in the plastics industry.

With the oscillation method, the output level is set alternately to 100 % and 0 %, which produces oscillation of the control variable. With the step response method, a step of a specified size

is made from the standby output. In both cases, the controller determines the optimum controller parameters from the response of the actual value.

⇒ Chapter "Optimization according to the oscillation method", page 86

⇒ Chapter "Optimization according to the step response method", page 87

Output type 1, 2

The cycle time is calculated on the basis of the type of controller output.

Optimized controller parameters

With both autotuning methods, certain parameters are optimized according to the configured controller type and configured parameters. The controller structure is derived from the type of the optimized parameters: Proportional band X_p (P component), derivative time T_v (D component), and reset time T_n (I component).

The cycle time C_y and the filter time constant dF are also optimized.

Configured controller type	Configured parameters	Optimized parameters	Optimized controller structure
Two-state controller	$X_{p1} = \text{any};$ $T_{v1} = 0; T_{n1} > 0$	$X_{p1}, T_{n1}, C_{y1}, dF$	PI
	All other settings	$X_{p1}, T_{v1}, T_{n1}, C_{y1}, dF$	PID
Three-state controller	$X_{p1} = X_{p2} = \text{any};$ $T_{v1} = 0; T_{n1} > 0$	$X_{p1}, X_{p2}, T_{n1}, C_{y1}, C_{y2}, dF$	PI
	All other settings	$X_{p1}, X_{p2}, T_{v1}, T_{n1}, C_{y1}, C_{y2}, dF$	PID
Three-step controller	$X_{p1} = \text{any};$ $T_{v1} = 0; T_{n1} > 0$	X_{p1}, T_{n1}, dF	PI
	All other settings	$X_{p1}, T_{v1}, T_{n1}, dF$	PID
Continuous controller	$X_{p1} = \text{any};$ $T_{v1} = 0; T_{n1} > 0$	X_{p1}, T_{n1}, dF	PI
	All other settings	$X_{p1}, T_{v1}, T_{n1}, dF$	PID
Position controller	$X_{p1} = \text{any};$ $T_{v1} = 0; T_{n1} > 0$	X_{p1}, T_{n1}, dF	PI
	All other settings	$X_{p1}, T_{v1}, T_{n1}, dF$	PID

For 1st-order control processes, the parameters required for the PI controller structure are optimized, independently of the configured parameters.

Error handling

If the actual value deviates above or below the measuring range during autotuning, autotuning is aborted. In this case, the configured parameters are not changed.



WARNING!

During autotuning according to the oscillation method, output value limits Y_1 and Y_2 are not active for switched outputs or solid state outputs.

The output level may exceed or fall below the set limits.

It must be ensured that this does not result in damage to the plant.

12 Configuration



NOTE!

The optimization must be performed under genuine operating conditions and requires a closed control loop, whose actuator influences the actual value (e.g. heating controlled by relay output). It can be performed as many times as required.

Start of autotuning

Autotuning can be started using any signal from the digital selector. Any other signal from the digital selector can be used to abort (stop) autotuning.

Optimization according to the oscillation method

In the case of a major control deviation between the setpoint value and actual value (for example, in the startup phase), the controller determines a switching line around which the control variable performs a forced oscillation during autotuning. The switching line is determined so that the actual value does not exceed the setpoint value if possible.

In the case of a minor control deviation (for example, if the control loop is in a steady state during operation), oscillation is forced around the setpoint value. Here, the setpoint value is exceeded in any case.

The controller automatically chooses between two procedures depending on the extent of the control deviation:

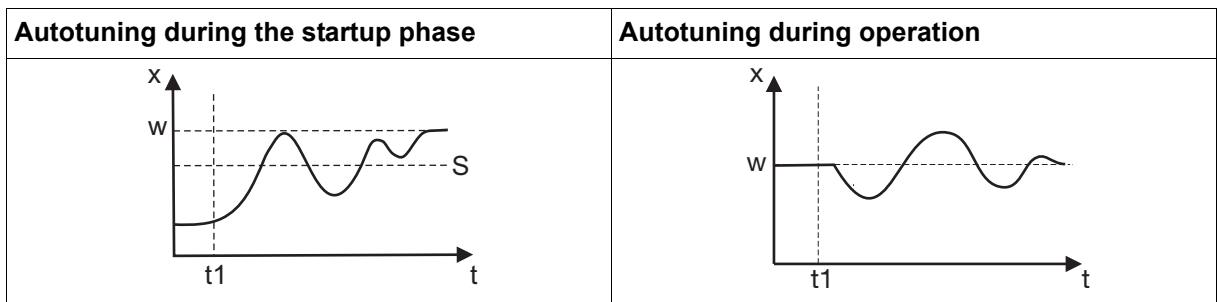

x Actual value
S Switching line

w Setpoint value
t1 Start of autotuning

Optimization according to the step response method

Initially, a configurable standby output is produced until the actual value "settles" to a constant. This is automatically followed by a configurable output level step (step size) to the control path.

Main applications of the step response method:

- Optimization immediately after "power on" during startup (considerable time saving, standby output setting = 0 %)
- Control process does not oscillate easily (for example, extremely well insulated furnace with low losses, long oscillation period)
- Actual value must not exceed the setpoint value

If the output level is known for the corrected setpoint value, overshooting is prevented with the following setting:

Standby output + step size \leq output level in corrected state

The progression of the output level and actual value depends on the status of the process at the point when autotuning starts:

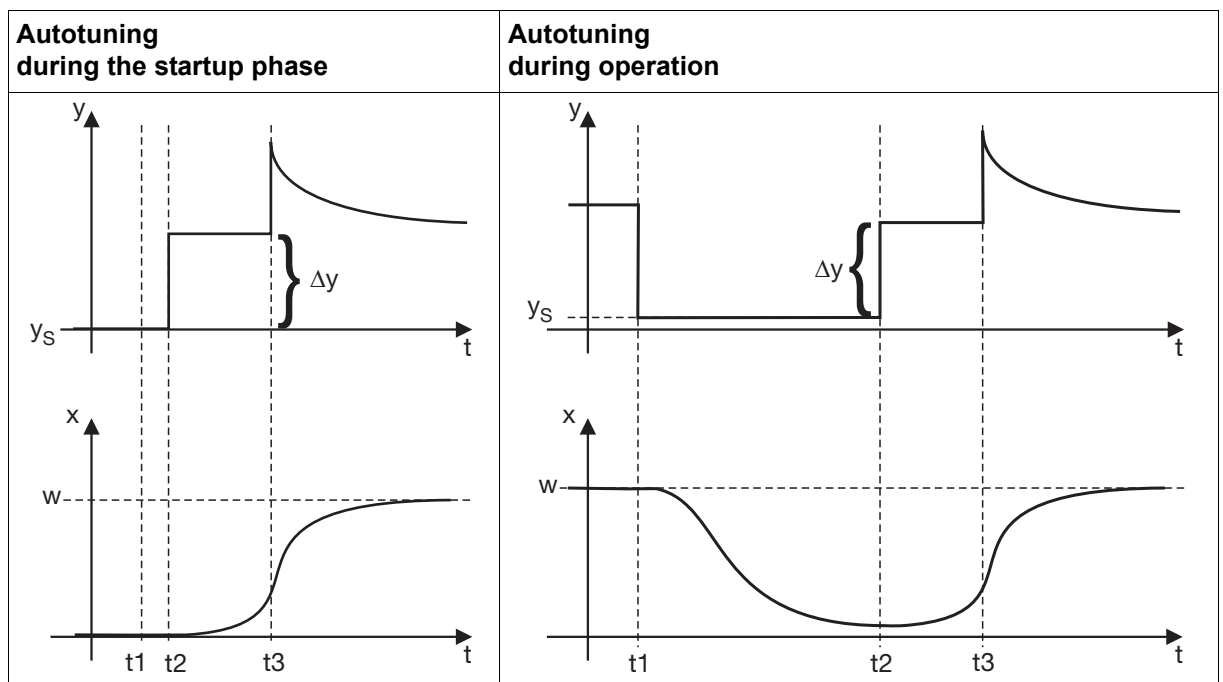

y Output level
 y_s Standby output
 x Actual value
 w Setpoint value

Δy Step size
 t1 Start of autotuning
 t2 Time of output level step
 t3 End of autotuning

12 Configuration

Checking the optimization

You can check that the controller has been optimally adjusted to the control process by recording the startup process (with "Startup", for example) with a closed control loop. The diagrams below indicate possible incorrect settings and how to correct them.

Here, the transient behavior of a 3rd-order control process for a PID controller is recorded as an example. The procedure for setting the controller parameters can also be applied to other control processes.

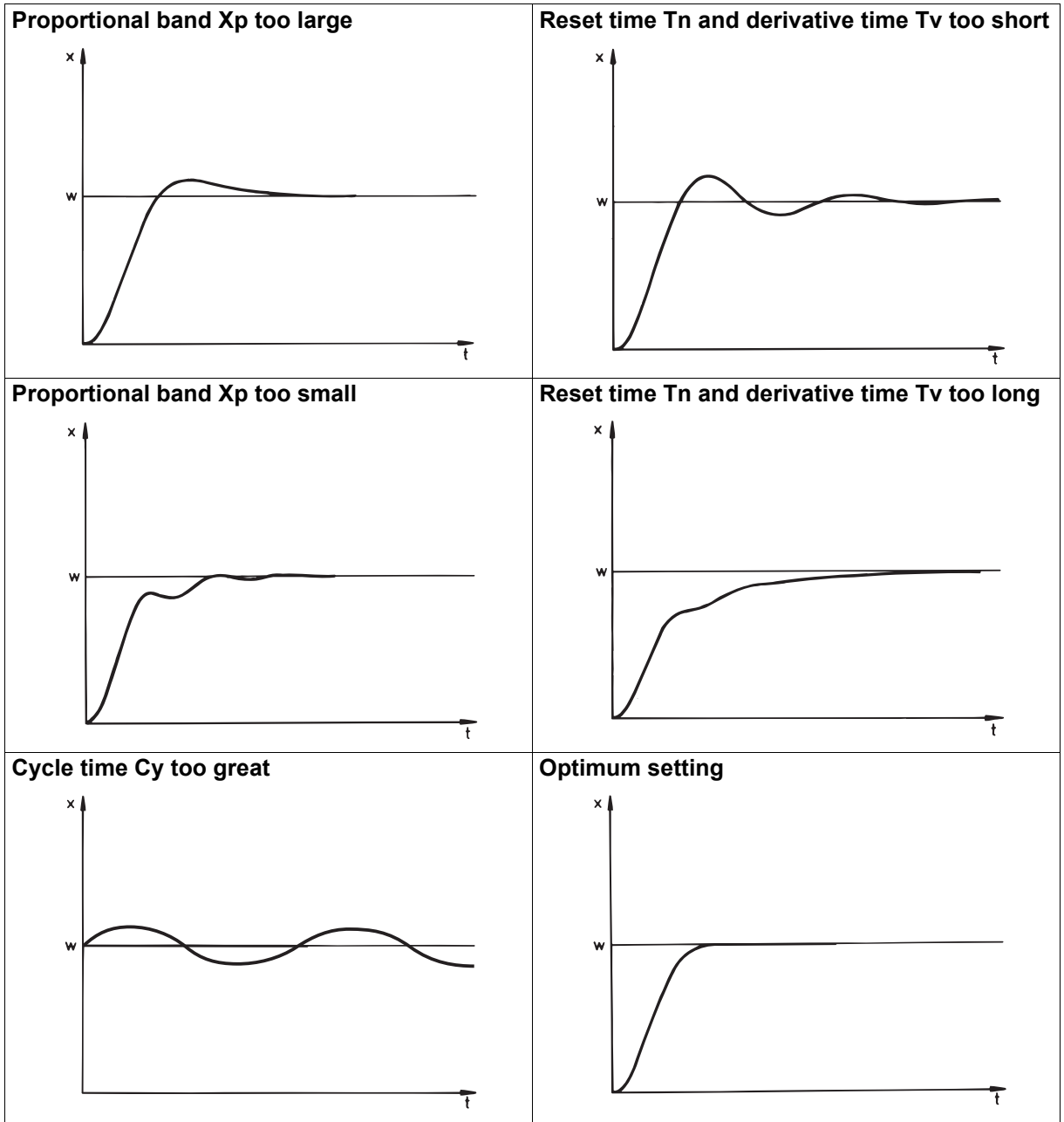



12.6.4 Starting autotuning (SO) on the device

This example describes the start of autotuning for a program controller. The following points must be taken into consideration, checked and, if necessary, adjusted:

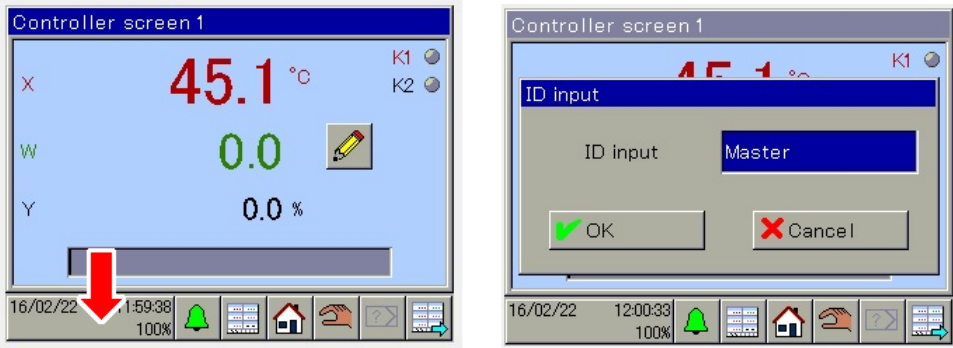
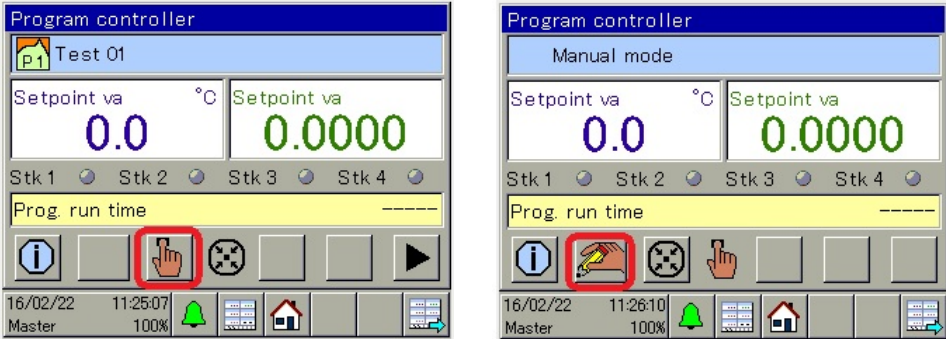
- Has the right controller type been configured? Check/set the controller's control direction. It must be possible to appropriately influence the actual value, e.g. by changing the output level in manual mode (closed control loop). Adjust the autotuning setting to match the type of outputs. Before starting the autotuning for the PID structure, the derivative time must not be set to 0. If the derivative time = 0, the PI structure is used for the optimization. Is the oscillation method appropriate for the case at hand, or do you need to switch to the step response method? (not possible with every controller series) Only in the case of the step response method: Meaningful specifications for the standby output and step size. Only in the case of a continuous controller: The function of the output must have been configured for the 1st controller output and scaled to 0 to 100%. (This means: Function = 1st controller output, zero point = 0, end value = 100) Only in the case of three-step controller: Determine the actuator runtime and set it in the parameter level.

Step	Activity
1	<p>The device is in the operating loop. Log in as a master from there</p> 
2	<p>From the basic status, switch the program controller to manual mode</p> 

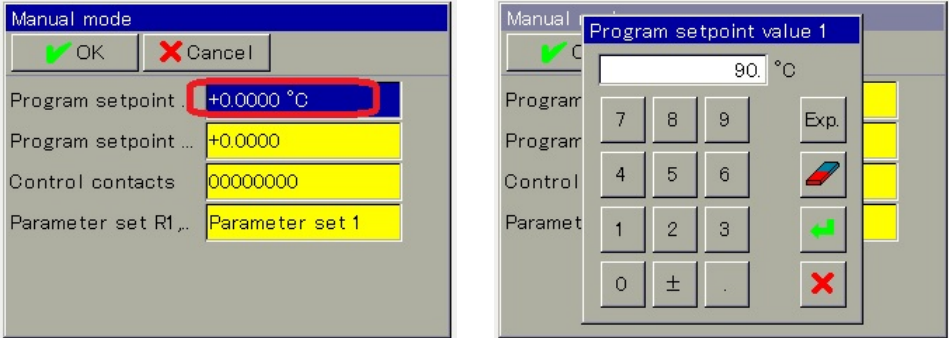
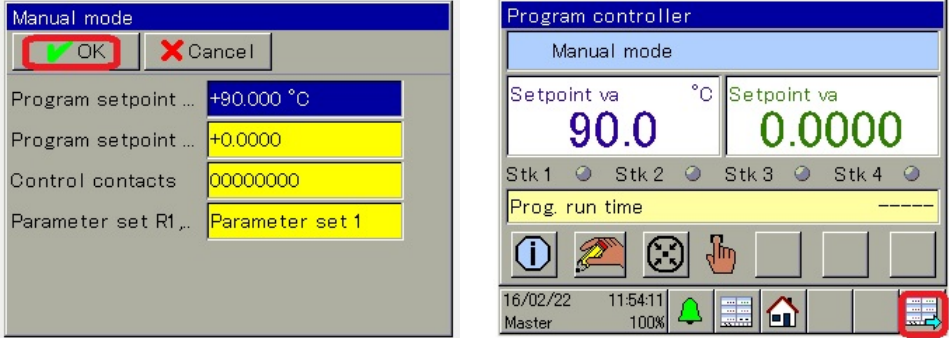
12 Configuration

Step	Activity
3	<p>Enter program setpoint value for manual mode</p> 
4	<p>Return to the controller screen by pressing OK</p> 
5	<p>Click on the symbol at the bottom for the SO and start by pressing OK</p> 
6	<p>The symbol on the right-hand side shows that the SO has started</p> 

➔ Result: The SO stores the determined controller parameters in controller parameter block 1.

12.6.5 Control loop monitoring

Control loop monitoring monitors the control response during startup of a plant and in the event of a setpoint step by analyzing the change of the actual value during an output level change. An alarm is issued if the actual value does not respond according to the specifications.

The alarm signal is available from the digital selector and can be processed further at any time.

Setup dialog box

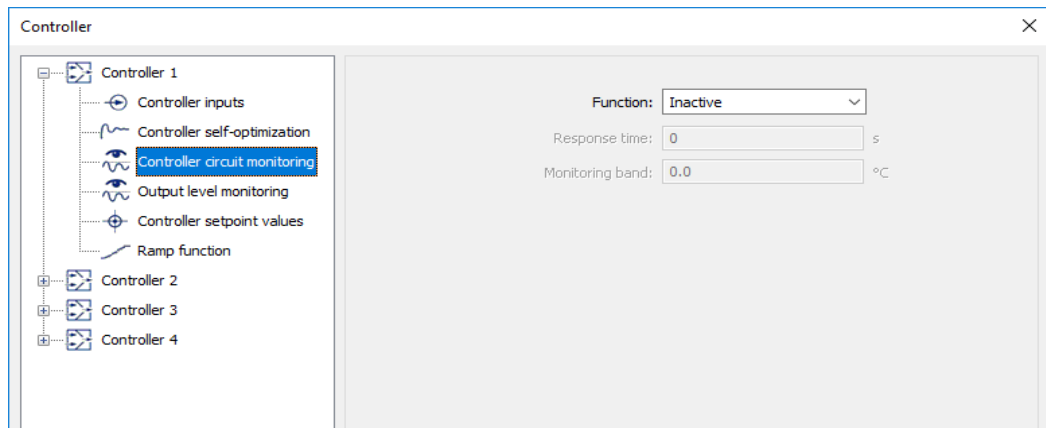

Parameters

Parameter	Selection/settings	Description
Function &	Inactive	Control loop monitoring is generally not permitted
	Active	Control loop monitoring is generally permitted
Response time	0 to 1999	Time period in which the actual value must leave the monitoring band. "0 s" setting means: Response time = reset time T_n
Monitoring band	0.0000 to 1999	Width of the monitoring band that the actual value must leave within the response time "0" setting means: Monitoring band = $0.5 \times$ proportional band (X_p)

12 Configuration

Description of the function

Monitoring starts as soon as the maximum output level is produced in heating mode (see example) or as soon as the minimum output level is produced in cooling mode. Starting from this point, the actual value must leave the monitoring band – the range around the current actual value at the start of monitoring – within the response time. If it does not, an alarm is triggered. On leaving the monitoring band, the actual value at the time is used as a reference value for a new monitoring band. The response time starts over.

Monitoring ends as soon as the maximum or minimum output level is no longer produced.

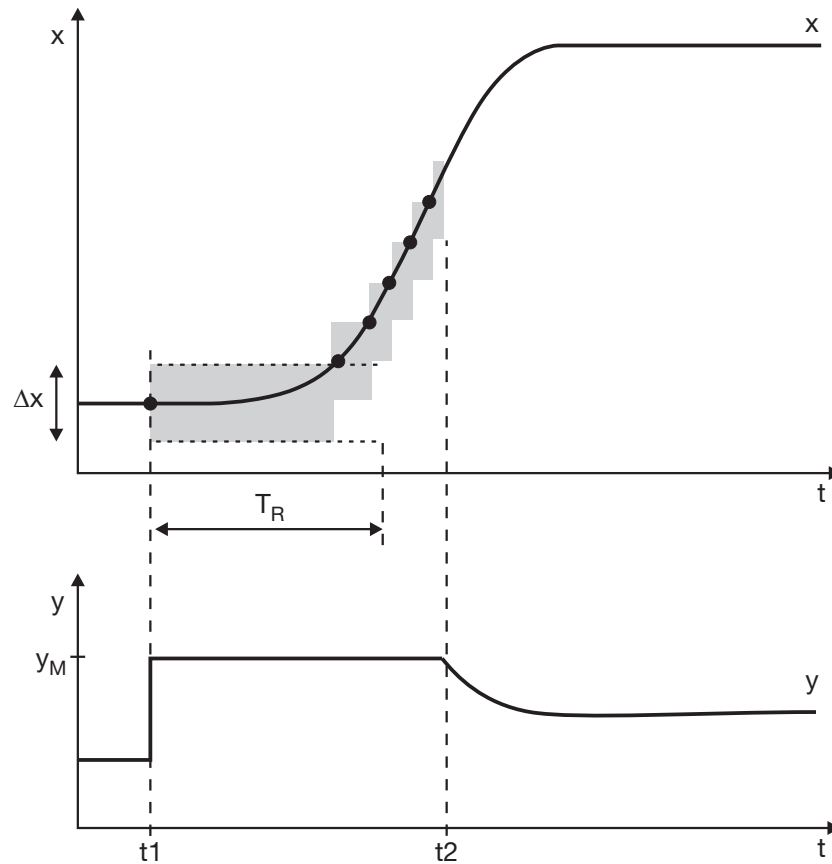

x Actual value
 y Output level
 t1 Start of monitoring
 t2 End of monitoring

Δx Monitoring band
 y_M Max. output level (for example, 100 %)
 T_R Response time

12 Configuration

If the actual value does not leave the monitoring band within this timeframe, an alarm signal is generated. The alarm signal is maintained for as long as the maximum or minimum output level is produced and the actual value is within the monitoring band.

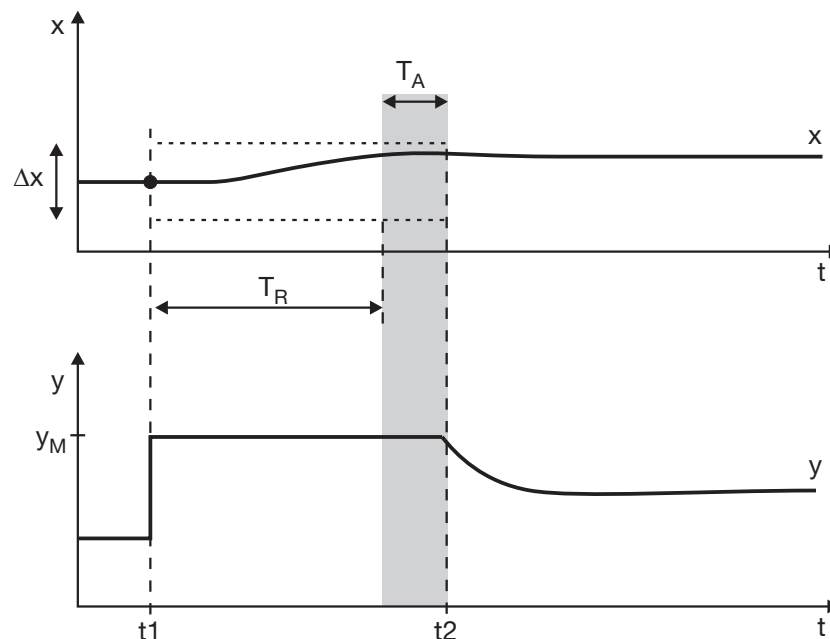

x	Actual value	Δx	Monitoring band
y	Output level	y_M	Max. output level (for example, 100 %)
t1	Start of monitoring	T_R	Response time
T_A	Alarm period	t2	End of monitoring

An alarm may be caused by:

- Partial or total failure of heating elements or other parts in the control loop
- Reversal of the control direction (for example, "cooling" instead of "heating")

12 Configuration

12.6.6 Output level monitoring

Output level monitoring monitors the output level in the corrected state. The output level must be within a definable range around a mean output level. If it is not, an alarm is issued.

The alarm signal is available from the digital selector and can be processed further at any time.

Setup dialog box

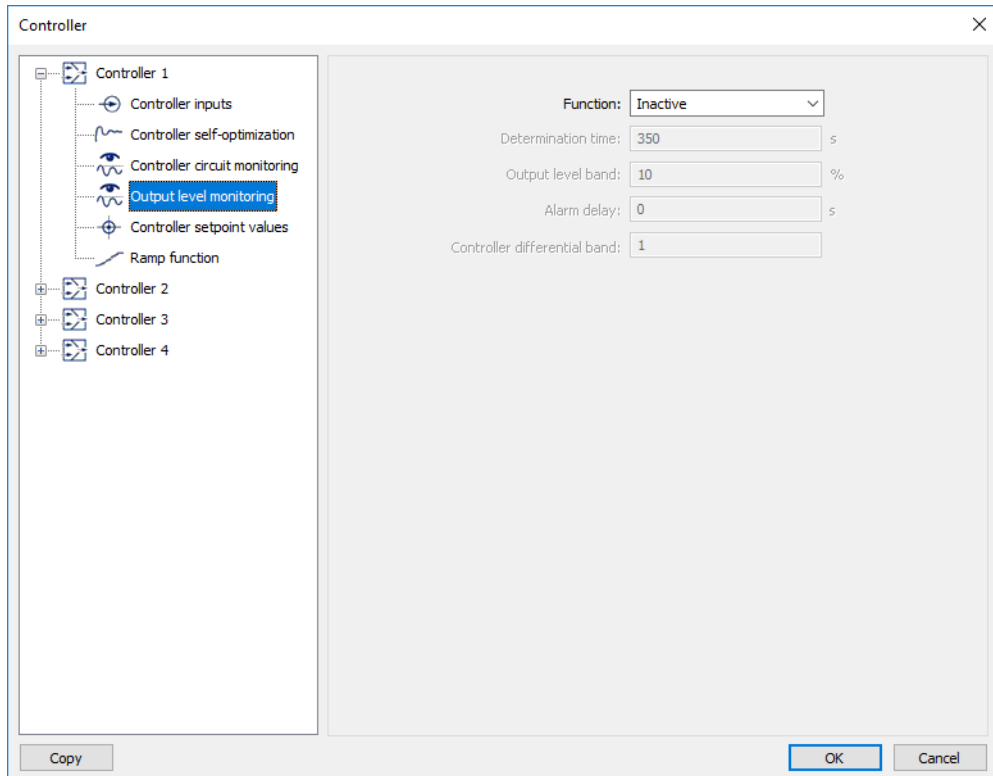

Parameters

Parameter	Selection/settings	Description
Locking	Inactive	Output level monitoring generally not permitted
	Active	Output level monitoring generally permitted
Determination time	0 s to 350 s to 9999 s	Calculation time for the mean output level
Output level band	0 % to 10 % to 100 %	Monitored output level band (admissible range around the mean output level)
Alarm delay	0 s to 9999 s	Delay time for alarm triggering
Control differential band	0 to 1 to 1999	Control differential band (admissible range around the actual value in corrected state)

Description of the function

Once the output level monitoring has been activated, determination of the mean output level starts as soon as the actual value is within the control differential band. When the mean output level has been determined, the current output level must be within the monitored output level band. If it is not, an alarm is triggered.

In the event of a setpoint value change, output level monitoring is temporarily deactivated until the actual value returns to the control differential band. The mean output level is then determined again.

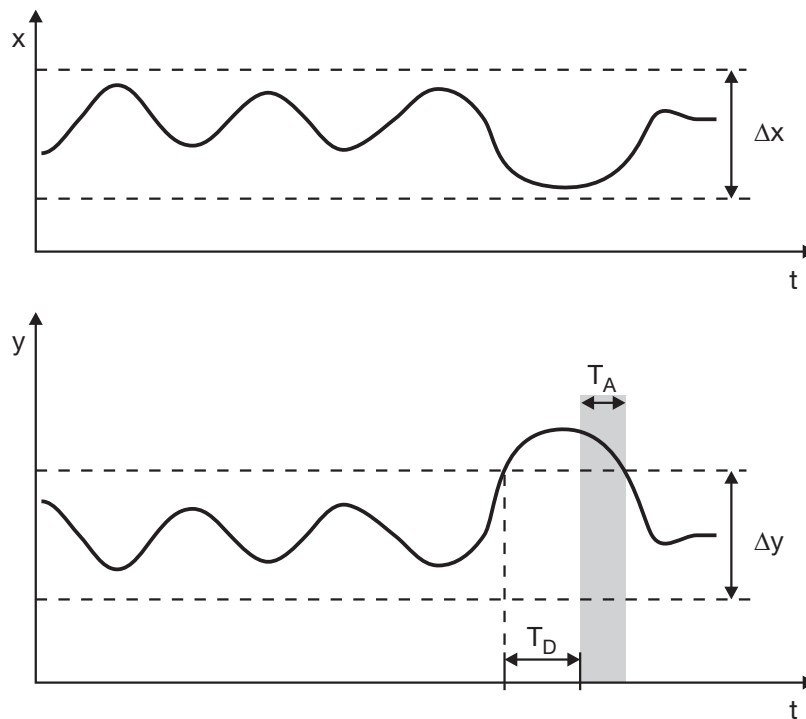

x Actual value
y Output level
 T_D Alarm delay

Δx Control differential band
 Δy Monitored output level band
 T_A Alarm period

Application examples:

- Monitoring of signs of aging and faults on heating elements
- Reporting of faults during operation

Functional limitations

Output level monitoring is not active in the following cases:

- Proportional band $X_p = 0$
- Autotuning active
- Manual mode
- Ramp function active
- Controller operating as program controller
- Three-step controller without output level feedback (or output level feedback in "out of range" status)
- Position controller with output level feedback in "out of range" status

12 Configuration

Parameter dimensioning

Appropriate dimensioning of parameters used for determining the mean output level is required for the output level monitoring to function correctly.

The **control differential band** around the actual value defines the corrected state. It should be dimensioned so that it is adhered to during normal operation. The progression of the actual value can, for example, be recorded with the recording function on the device or with the startup function of the setup program. Determination of the mean output level starts when the actual value enters the control differential band. Calculation of the mean output level starts over if there is a temporary deviation from the control differential band when determining the output level or if the setpoint value is changed by more than $0.5 \times$ control differential band Δx .

A mean output level is calculated via the **determination time** using a moving average. The time selected should be long enough to ensure the calculation is as accurate as possible. The determination time is followed by a waiting period of $0.5 \times$ reset time T_n , during which it is checked whether the actual value and output level move within the specified limits. If one of the limits is exceeded, the calculation restarts. After successful calculation, the output level monitoring is active.

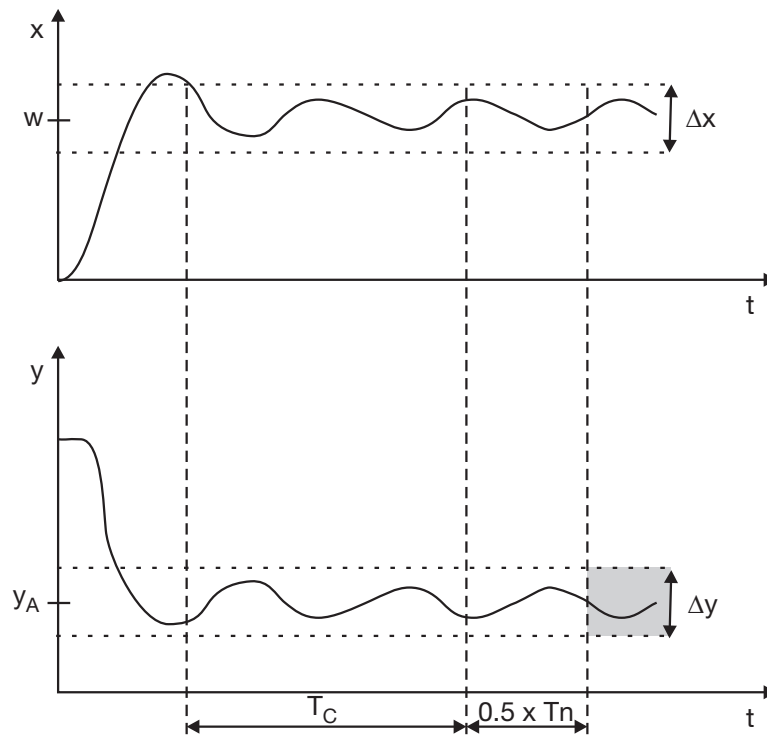

- | | | | |
|----------------|--------------------|----------------|---------------------------|
| x | Actual value | w | Setpoint value |
| y | Output level | y _A | Average output level |
| T _C | Determination time | T _n | Reset time |
| Δy | Output level band | Δx | Control differential band |

12.6.7 Controller setpoint values

With this separate setpoint value function, the setpoint values and the ramp function can be configured flexibly for each of the control channels (Controller 1 to 4).

Up to four setpoint values are available for each control channel and can be switched using two digital signals.

The analog signal for the setpoint specification (external setpoint value 1 to 2) is selected from the analog selector. A correction value (setpoint value 1 to 4) can be applied to this signal. If no analog signal is selected (inactive), the correction value acts as a fixed setpoint value.



NOTE!

The active setpoint value is not automatically used as a setpoint value for the control channel; it must first be assigned in the controller configuration (see Chapter 12.6.2 "Controller inputs", page 82).



NOTE!

If an analog signal is used as a setpoint value without a correction value, it can also be directly assigned in the controller configuration. In this case, setpoint value limitation, setpoint changeover, and the ramp function are not available.

Equally, a fixed setpoint value can be assigned directly in the controller configuration (see Chapter 12.6.2 "Controller inputs", page 82).

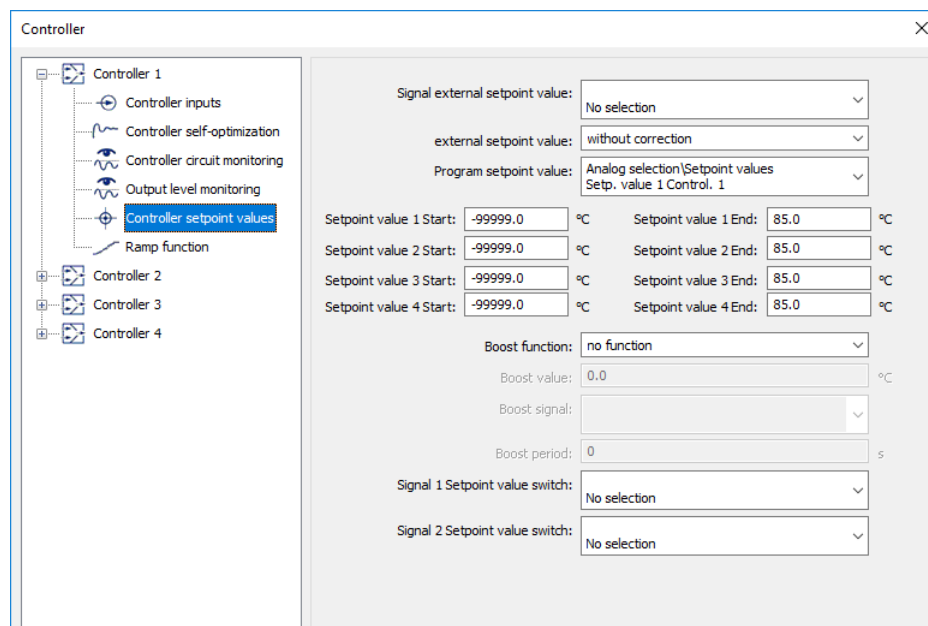

Setup dialog box



Parameters

Parameter	Selection/settings	Description
Signal for ext. setpoint value	No function Analog selector	Signal source for ext. setpoint value.
External setpoint value	No correction	No ext. setpoint value correction takes place

12 Configuration

Parameter	Selection/settings	Description
	With correction	The external setpoint value is added to the internal setpoint value of the fixed setpoint controller or program controller.
Program setpoint value 	Program setpoint value 1 Program setpoint value 2	The source for the program setpoint value is selected here for the active program controller.
Setpoint value 1 to 4 start	-99999 to +99999	Setpoint limit start
Setpoint value 1 to 4 end	-99999 to +99999	Setpoint limit end
Boost function &	No function	Boost function switched off
	Delta value	Setpoint value is increased by a delta value.
	Percentage value	Setpoint value is increased by a percentage value.
Boost value	0.0000 to 99999	Amount by which the setpoint value is increased (in K or % of the setpoint value)
Boost signal	No selection	-
	Digital selector	The boost function is switched on using this signal.
Boost duration	0 to 999	Duration of boost period (in s)
Signal 1 setpoint change-over 	No selection Digital selector	Signal 1 is selected here for the setpoint changeover for the fixed-setpoint controller.
Signal 2 setpoint change-over 		Signal 2 is selected here for the setpoint changeover for the fixed-setpoint controller.

Program setpoint value

This setting is only available if the program controller has been configured. The setpoint values then come from the program profiles that are entered.

Boost function

The boost function is used to release tools in the plastics industry during the production process. The setpoint values for all heating zones are thereby increased by a specific delta or percentage value for a specific time period.

Setpoint changeover

The setpoint values 1 to 4 for the fixed-setpoint controllers are located in the parameter level and can be entered as follows:

⇒ Chapter 11.4 "Setpoint values", page 64

Switching can be performed using digital signals from the digital selector.

Signal 2 (Bit 1) setpoint changeover	Signal 1 (Bit 0) setpoint changeover	Active setpoint value, Controller 1	Active setpoint value, Controller 2
0	0	Setpoint value 1	Setpoint value 1
0	1	Setpoint value 2	Setpoint value 2
1	0	Setpoint value 3	Setpoint value 3
1	1	Setpoint value 4	Setpoint value 4

12.6.8 Ramp function



The ramp function enables the setpoint value to be continually changed up to the ramp end value (active setpoint value).

A tolerance band can be set around the setpoint value curve to monitor the actual value. If the actual value deviates from the tolerance band, a digital signal (tolerance band signal) is activated.

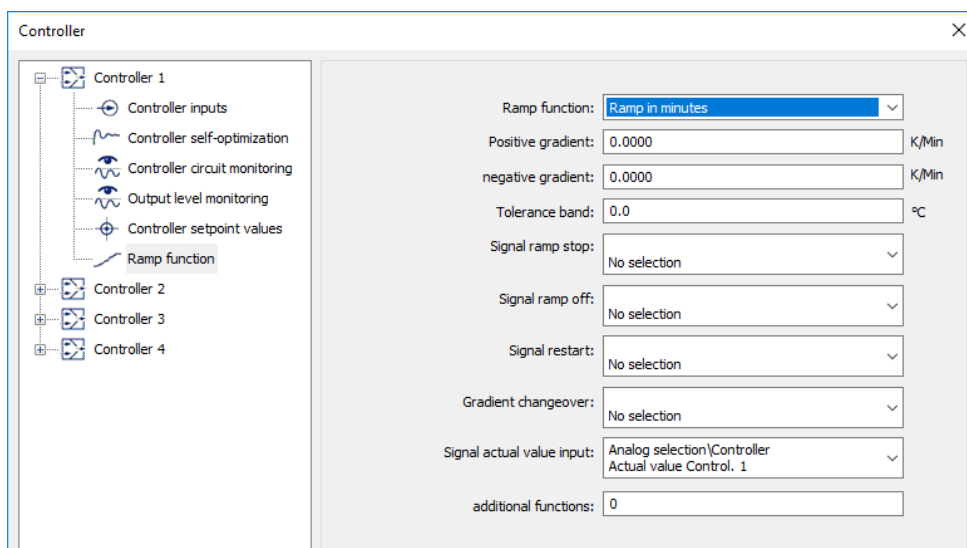
Setup dialog box



Parameters

Parameter	Selection/settings	Description
Ramp function 	Ramp off Ramp in minutes Ramp in hours Ramp in days	Ramp function switched off Ramp function switched on
Positive gradient	0.00 to 999.00	In the event of a setpoint value step, the ramp rises depending on the time unit that has been set.
Negative gradient	0.00 to 999.00	In the event of a setpoint value step, the ramp falls depending on the time unit that has been set.
Tolerance band 	0.00 to 999.00	The tolerance band monitors deviation of the actual value from the current setpoint value (tolerance band = admissible deviation)
Signal for ramp stop	No selection Digital selector	The ramp can be stopped with this signal (see t4 in image)

12 Configuration

Parameter	Selection/settings	Description
Signal for ramp off	No selection Digital selector	The ramp can be switched off with this signal. With a binary signal, the ramp end value is applied only once (in the case of a rising edge) as the current controller setpoint value in the form of a step without a ramp. If the ramp end value is changed again, this behavior is no longer active and the ramp end value is approached again as a ramp with the specified gradient.
Restart signal	No selection Digital selector	The ramp can be restarted with this signal
Signal actual value input	Analog selector/Controller 1 Actual value controller 1	This actual value is monitored by the tolerance band
Additional functions (only setup)	0.00 to 999.00	Reserved functions for service

Ramp function

This function creates a ramp-like setpoint curve out of a step-like setpoint curve, where the rising and falling edges can have different gradients.

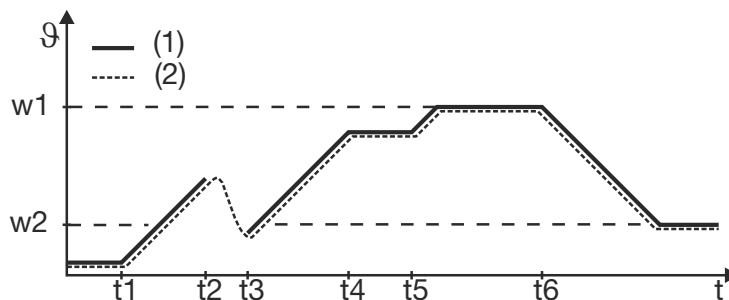

- t1 Power ON
 - t2 to t3 Power failure, manual mode, probe break
 - t3 Ramp start at current actual value
 - t4 to t5 Ramp stop by digital input
 - t6 Setpoint changeover to w2
- (1) Setpoint value
(2) Actual value

Tolerance band function

In the case of a program controller and ramp function, a tolerance band can be set around the setpoint value curve in order to monitor the actual value. If the upper or lower limits are exceeded, a tolerance band signal is triggered, which can be processed further internally or issued via an output.

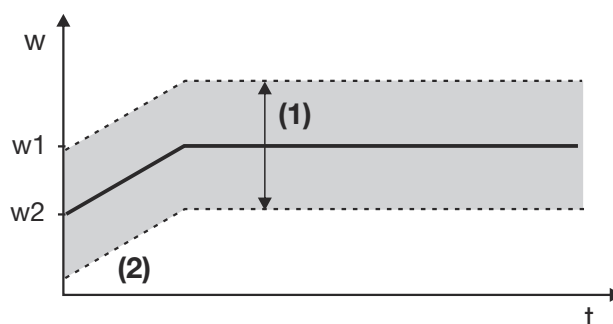

- (1) Tolerance band
- (2) Ramp

12.7 Digital outputs

Depending on how the expansion slots have been equipped, 2 fixed digital outputs called OUT1 and OUT2 and 10 additional digital outputs (OUT3/4 to OUT11/12) are available.

Setup dialog box

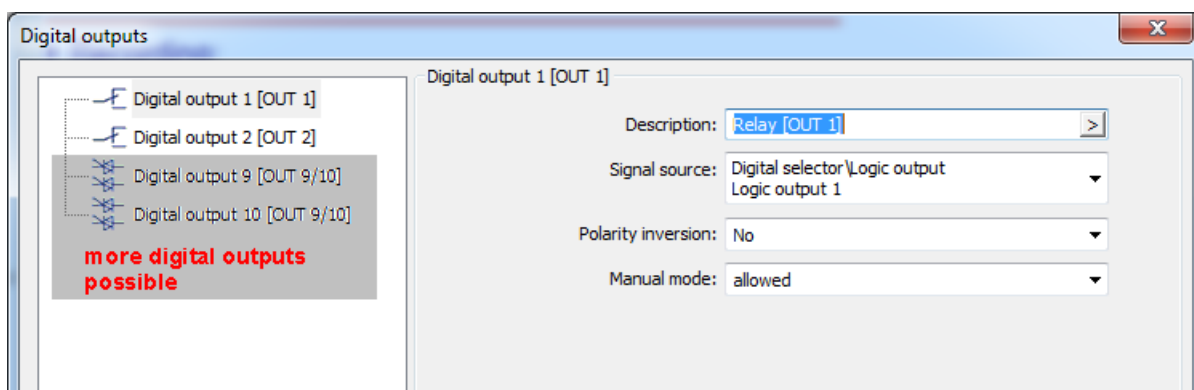

Parameters

Parameter	Selection/settings	Description
Description	Relay [OUT 1]	(15 characters) editable text For example, for the signal that is issued via the digital output.
Signal source	Digital selector/controller 1st output, Controller 1	This signal is issued at the digital output.
Polarity inversion	No Yes	Switching behavior remains unchanged Inverts the switching behavior
Manual mode	Not allowed Allowed	Digital output can be edited in manual mode.
Description	Relay [OUT 2]	Signal designation issued via the digital output. Inactive = output inactive

12 Configuration

Parameter	Selection/settings	Description
Signal source	Digital selector/controller 2nd output, Controller 1	This signal is issued at the digital output.
Polarity inversion	No Yes	Switching behavior remains unchanged Inverts the switching behavior
Manual mode	Not allowed Allowed	Digital output signal can be edited in manual mode.

12.7.1 Switching digital outputs to logic level 1 as a fixed setting

If the digital output is to be used as a voltage supply for transmitter, it needs to be linked with a signal that permanently sets it to logic level 1.
This can be done by setting the signal source as: Service -> One signal.

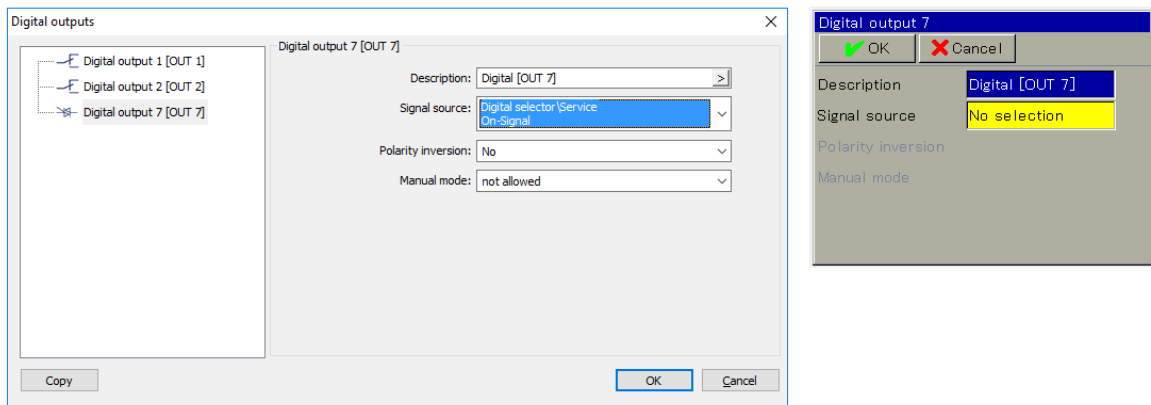

1 logic output DC 0/22 V, max. 30 mA



The logic output can now be used as a voltage supply for transmitter.
See Chapter 17.3.1 "Accessories", page 186

12.7.2 Switching digital outputs to manual mode

If it should be possible to switch digital outputs on the device using manual mode, this must be enabled using the setup program or in the device configuration.

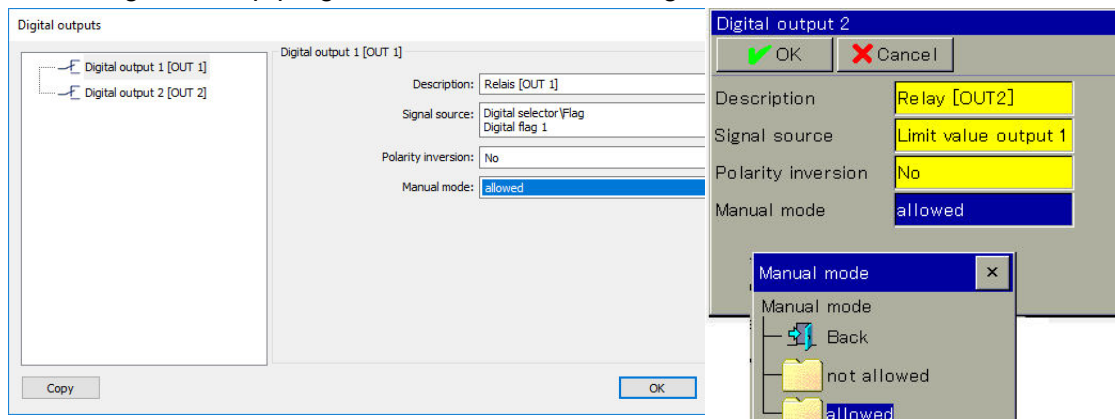

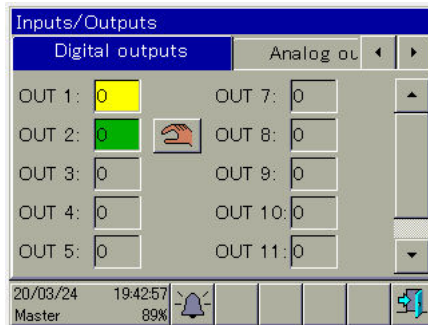

In the Device info menu, a hand symbol now appears by the switching output. If you tap the hand symbol, the Out 2 relay is actuated.

See Chapter 9.3.1 "Digital and analog inputs, digital and analog outputs, external digital, and external analog inputs", page 54

12.8 Analog outputs

A maximum of three analog outputs can be configured as current or voltage outputs (standard signal) and are freely scalable.

Setup dialog box

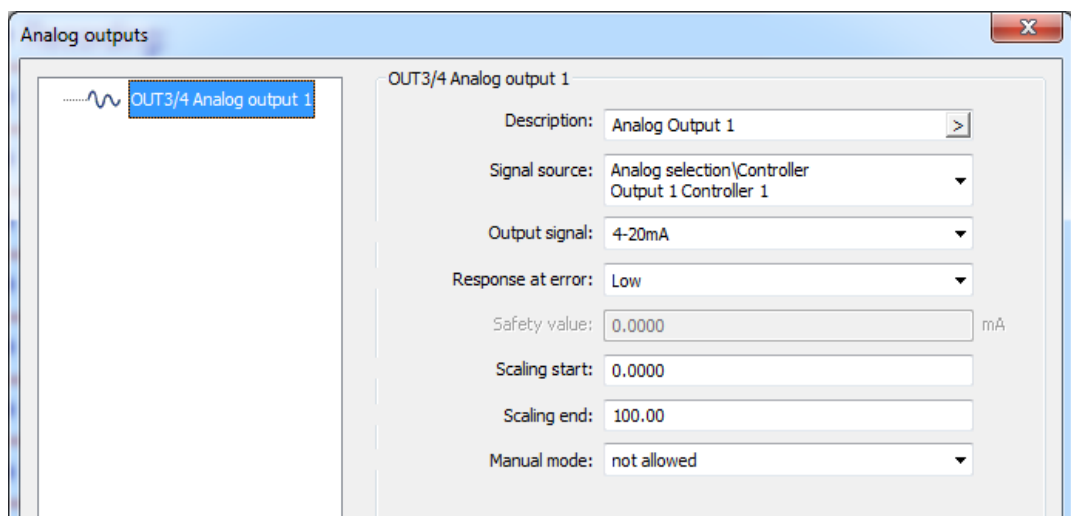

Parameters

Parameter	Selection/settings	Description
Description	Analog Output 1	(15 characters) of editable text for the signal issued via the analog output (for example, a math function result).
Signal source	No selection Analog selector	- This signal is issued via the analog output.
Output signal	0-10 V 0-20 mA 4-20 mA 2-10 V	
Response at error	Low	Lower standard-signal limit is issued

12 Configuration

Parameter	Selection/settings	Description
	High NAMUR Low NAMUR High Frozen Safety value	Upper standard-signal limit is issued See table (limits according to NAMUR) See table (limits according to NAMUR) Retains the last valid value Issues the set replacement value
Safety value	For example, 0 to 10 V	Replacement value which can be set within the output signal limits (for example, 0 to 10 V).
Scaling start	0.00 to 100.00	
Scaling end	100.00 to 0.00	
Manual mode	Not allowed	Analog output not editable in manual mode
	Allowed	Analog output editable in manual mode.

Response at error

Limits according to NAMUR recommendation NE 43:

	Signal type 2 to 10 V	Signal type 4 to 20 mA
Measurement information M	1.9 to 10.25 V	3.8 to 20.5 mA
Failure information A for deviation below measured value/short-circuit ("NAMUR Low")	≤ 1.8 V	≤ 3.6 mA
Failure information A for deviation above measured value/probe break ("NAMUR High")	≥ 10.5 V	≥ 21 mA

Zero point and end value

A value range is assigned to the physical output signal by specifying the zero point and end value (scaling). The default setting corresponds to a value range of 0 to 100 (for example, an output level of 0 % to 100 % for a controller output).

If, for example, a temperature with a value range from 150 °C to 500 °C is to be issued via an analog output with signal type 0 to 20 mA, the zero point must be set to 150 (corresponds to 0 mA) and the end value set to 500 (corresponds to 20 mA).

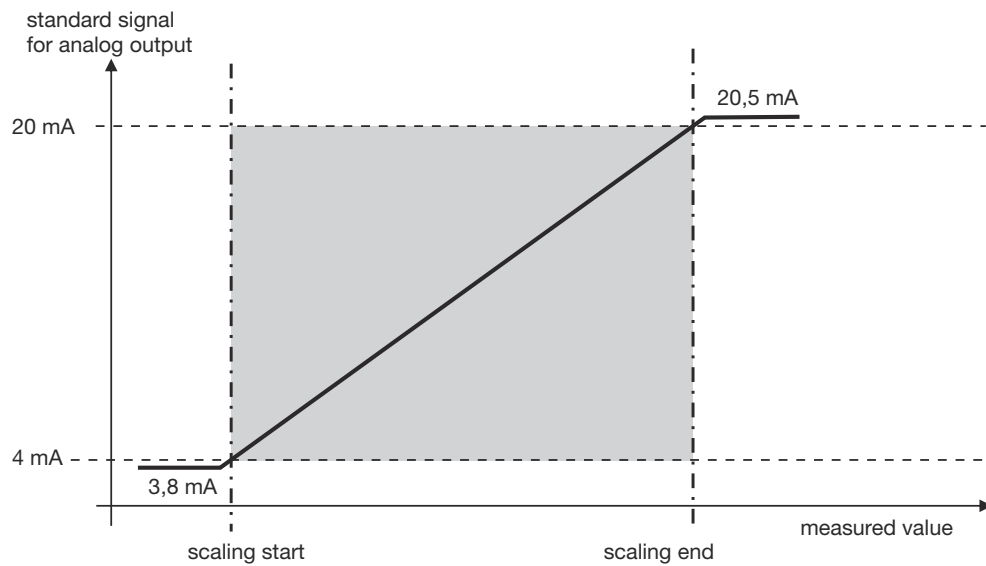

Status after change of configuration

Modified parameters are incorporated immediately.

Behavior after power on

During the initialization phase of the controller module, the output signal adopts a value of 0 % (in relation to the value range of the signal type).

Error handling

The behavior in the event of deviation above or below the measuring range (out of range) can be configured. The settings made there also apply for probe/conductor breaks or probe/conductor short-circuits. This results in a safe state for operation in the event of an error.

Error detection depends on the type of measuring probe (see technical data, measuring circuit monitoring).

12 Configuration

12.9 Limit value monitoring function

One of eight alarm functions can be selected for each of the 16 limit value monitoring functions, to monitor a freely selectable input value (actual value) against a fixed limit value AF7 and AF8 or a limit value related to the setpoint value (setpoint value \pm limit value) (AF1 to AF6). Each limit value monitoring function delivers an output signal that can be linked to or issued at a digital output.

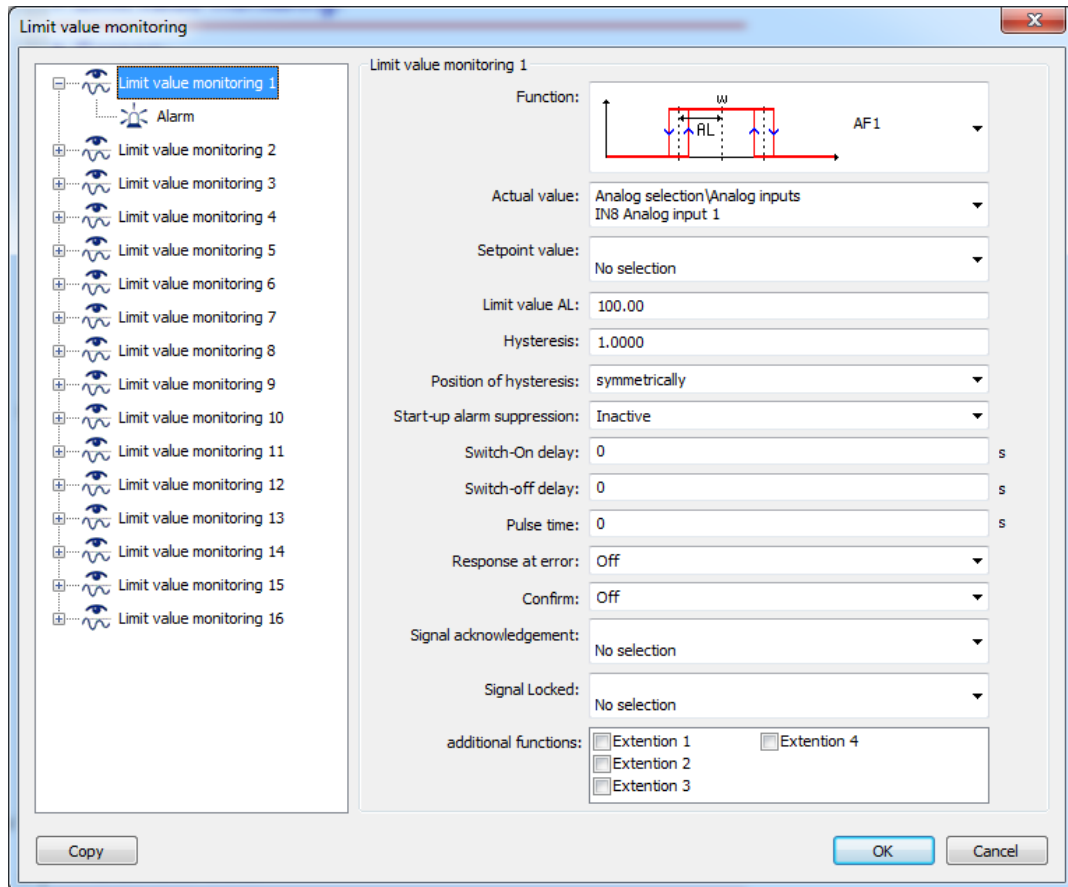

Setup dialog box



Parameters

Parameter	Selection/settings	Description
Function	No function AF1 to AF8	Alarm function (AF 1 to 8) can be selected
Actual value	No selection Analog selector	Analog signal to be monitored
Setpoint value	No selection Analog selector	Setpoint value w (reference signal for AF1 to AF6)
Limit value AL	0.0000 to 99999	- For AF1 to 6, in relation to a changing setpoint value w - For AF7 and AF8, in relation to a fixed limit value
Hysteresis	0.0000 to 1 to 9999.9	Switching distance between switch-on and switch-off

12 Configuration

Parameter	Selection/settings	Description
Position of hysteresis	Symmetrically Non-standard left Non-standard right	Here you can adjust the setting for which side the hysteresis should be on.
Start-up alarm suppression 	Inactive	AF switching behavior is not suppressed
	Active	AF switching behavior is suppressed, provided that the value was not within the valid range.
Switch-On delay	0.0000 to 99999	Once the AF event has occurred, the time for the switch-on delay begins to elapse. The AF output remains unchanged at first until the time set here has completely elapsed and the AF event is relayed to the AF output. If the AF actual value leaves the "bad range" during this time for the switch-on delay, the count-down begins again for each new limit value violation.
Switch-off delay	0.0000 to 99999	Identical behavior as with switch-on delay, except that the AF switch-off process is delayed. The lock takes priority over the switch-off delay.
Pulse time	0.0000 to 99999	AF output is automatically deactivated after the pulse time. The output is only re-activated to the maximum level via the set pulse time after repeated deviation above or below the alarm values. The lock takes priority over the pulse function.
Response at error	Off	AF output is switched off in the event of an error
	On	AF output is switched on in the event of an error
Confirm 	Off	The alarm function is automatically reset following a limit value violation.
	"Inactive" status	The lock can only be acknowledged if the AF actual value is back in the valid range.
	"Active" status	The lock can always be acknowledged if it has been activated
Signal acknowledgement	No selection	No acknowledgement possible
	Digital selector	This signal acknowledges the lock.
Signal Locked	No selection Digital selector	The "Signal Locked" input can be used to set and maintain the output signal of the limit value monitoring function at the logical value "0". As a result, alarms will be suppressed. This means: As long as "1" is applied at the input for "Signal Locked", the output of the limit value monitoring function will always be "0"
Additional functions Not selected (empty)		
(setup only)	<input type="checkbox"/> Extension 1	Reserved functions for service
	<input type="checkbox"/> Extension 2	
	<input type="checkbox"/> Extension 3	
	<input type="checkbox"/> Extension 4	

12 Configuration

12.9.1 Function and hysteresis

For the AF1 to AF6 alarm functions, the final limit value depends on the setpoint value – the entered limit value is added to or subtracted from the setpoint value. The AF7 and AF8 alarm functions work with a fixed limit value which corresponds to the limit value entered. Shown with the associated hysteresis functions (non-standard left, symmetrically, non-standard right)

Limit value in relation to the setpoint value

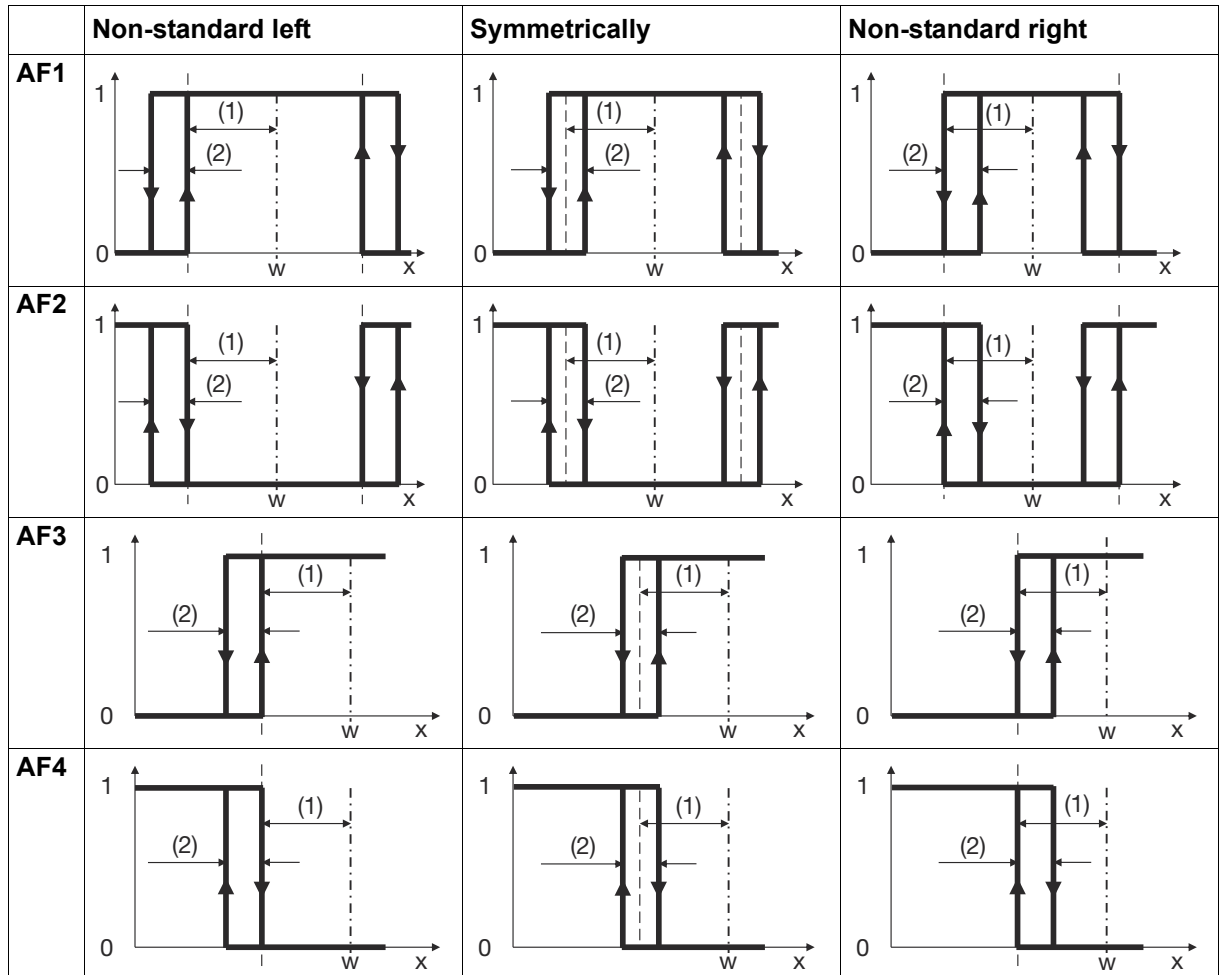

- 1 Output signal active
- 0 Output signal not active
- x Actual value
- w Setpoint value
- (1) Limit value (setpoint value distance)
- (2) Hysteresis

12 Configuration

12.9.3 Startup alarm suppression

Active startup alarm suppression means:

- After power on, the output signal remains inactive, even if the actual value is in the alarm range.
- If the limit value or setpoint value is changed so that the actual value moves from outside of the alarm range to within the alarm range, the output signal remains inactive
- The limit value monitoring only starts to operate according to its alarm function again once the actual value has left the alarm range. This means that the output signal remains inactive until the actual value returns to the alarm range.

Example of active startup alarm suppression

The following example shows monitoring of the actual value "x" with the alarm function AF4 (without hysteresis) for a specified limit value (1). The setpoint value is changed from w1 to w2.

Initial state: The output signal is not active as the actual value is outside of the alarm range (gray area).

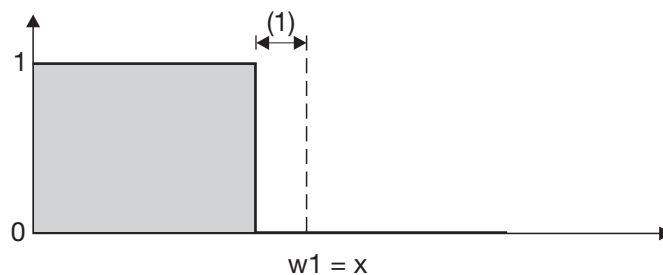

Change of setpoint value: The output signal remains inactive, although the actual value is now within the alarm range.

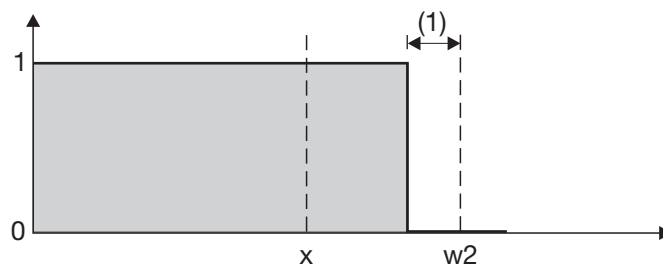

Corrected state: The actual value has left the alarm range and reached the new setpoint value. The output signal remains inactive until the actual value returns to the alarm range.

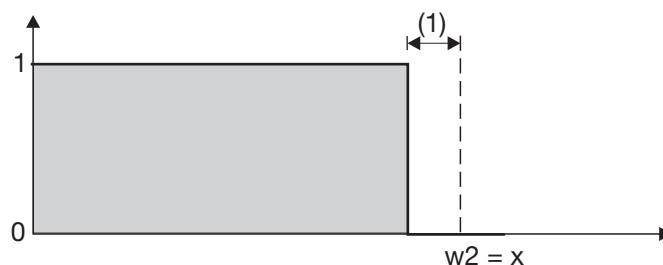

12.9.4 Acknowledging the lock

If an alarm function has been set to monitor an important process temperature, for example, it may be necessary for the function to not switch back automatically, and instead remain perma-

nently in this state.

If **INACTIVE** has been set, this lock cannot be acknowledged until the actual value is back within the admissible range.

If **ACTIVE** has been set, this lock can always be acknowledged.

The lock takes priority over the switch-off delay.

12.9.5 Alarm

In addition to evaluation of the limit value monitoring output signal, there is also the option to make an entry in the event list in the case of an alarm.

Setup dialog box

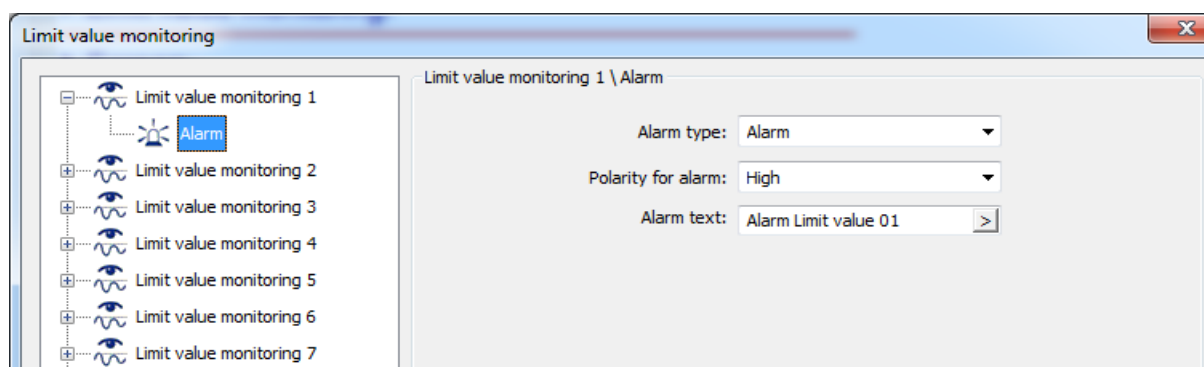

Parameters

Parameter	Selection/settings	Description
Alarm type	Off	Alarm switched off.
	Alarm	A message will be entered in the alarm list depending on the signal level that has been set.
	Event	A message will be entered in the event list depending on the signal level that has been set.
Polarity for alarm	High	Limit value monitoring function: High (logic level 1)
	Low	Limit value monitoring function: Low (logic level 0)
Alarm text 	Alarm Limit value 01	20 characters of editable text which is entered into the alarm or event list.

Alarm text

Setup program: Selection of text from a list

Clicking on the ">" button opens a list with text numbers and the associated texts. The texts are editable.

12 Configuration

12.10 Screen

The screen selection and the appearance of those screens in the operating loop is set using this function.

12.10.1 General configuration

Setup dialog box

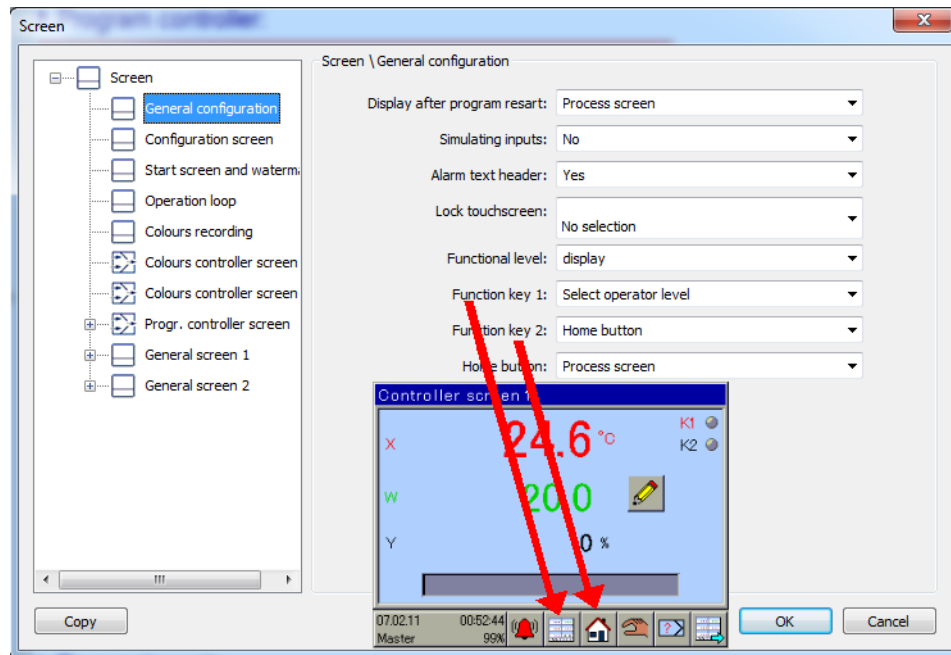

Parameters

Parameter	Selection/settings	Description
Display after program restart	Controller screen 1	Any of the screens in the operating loop can be selected as the start screen.
Simulating inputs	No	Genuine recorded data is shown.
	Yes	Simulated data is displayed within the measuring range.
Alarm text header	Yes	Alarms are inserted cyclically in the header.
	No	Alarms are not inserted.
Lock touchscreen	No selection	The screen can be locked to prevent unauthorized operation.
	Digital selector	
Functional level	Display	⇒ Chapter 10.1 "General information", page 57
	Hide	
Function key 1	Select operator level	A selection of functions that can be started using the function buttons appears here.
Function key 2	Home button	
Home button	Controller screen 1	Any of the screens in the operating loop can be selected.

12.10.2 Configuration screen

The screen brightness and the screensaver can be set using this function.

Setup dialog box

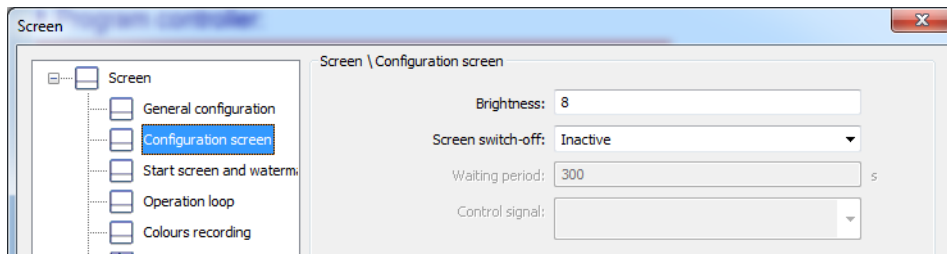

Parameters

Parameter	Selection/settings	Description
Brightness	0 to 8 to 10	Screen brightness
Screen switch-off	Inactive	Screen is always on
	Waiting period	Screen is switched off following a waiting period.
	Control signal	Screen is switched off with a signal.
Waiting period	10 to 300 to 32767 s	If the screen is not touched, it will turn off after this period.
Control signal	No selection	No switch-off
	Digital selector	This signal switches the screen off.

12.10.3 Start screen and watermark

Background images and watermarks are set using this function.

Setup dialog box

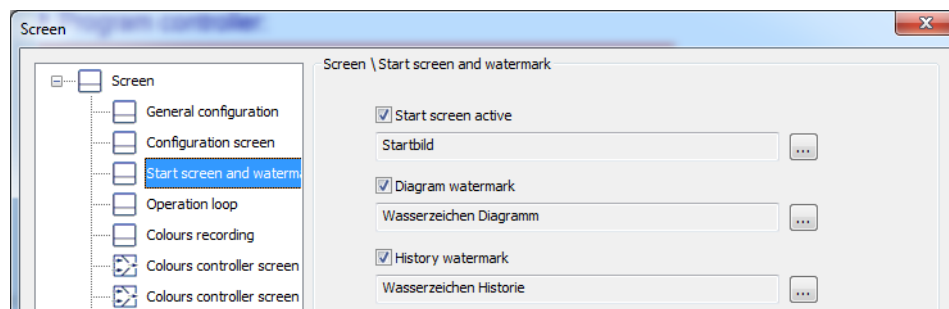

Parameters

Parameter	Selection/settings	Description
Start screen active	Default setting is JUMO Sensors+Automation	Any screen shown with power ON (for example, your company logo).
Diagram watermark	Default setting is JUMO	Any screen shown as a watermark in the recorder screen.
History watermark		

12 Configuration

12.10.4 Operation loop

Screens are set to appear in the operating loop using this function.

Setup dialog box

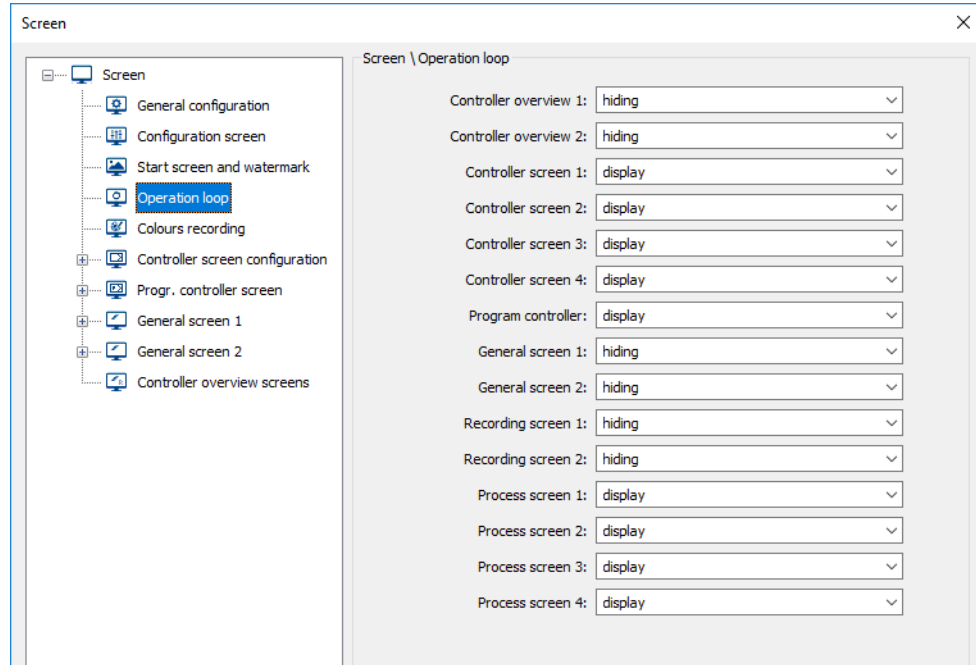

Parameters (only setup)

Parameter	Selection/settings	Description
Controller screen 1 to 4	Display/do not display	
Controller overview	Display/do not display	
Program controller	Display/do not display	
General screen 1	Display/do not display	
General screen 2	Display/do not display	
Process screen 1 to 4	Display/do not display	

12.10.5 Colors recording

The colors for the channels and alarms displayed can be set using this function.

Setup dialog box

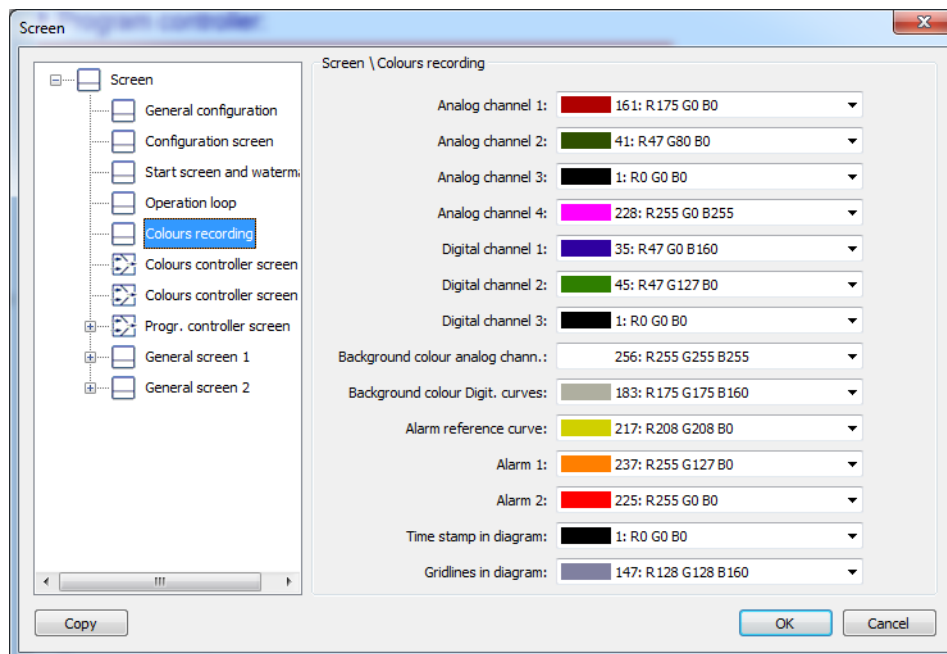

Parameters

Parameter	Selection/settings	Description
Analog channel 1 to 4		The color for the recording data can be selected in the RGB color selector.
Digital channel 1 to 3		
Background color analog chann.		
Background color Digit. curves		
Alarm reference curve		
Alarm 1		
Alarm 2		
Time stamp in diagram		
Gridlines in diagram		

12 Configuration

12.10.6 Colors, designations in controller screen 1 to 4

The colors for controller screen 1 to 4 can be set using this function. The designations for the setpoint value, actual value, output level, contact 1 and 2, and the associated signal sources can also be set.

Setup dialog box

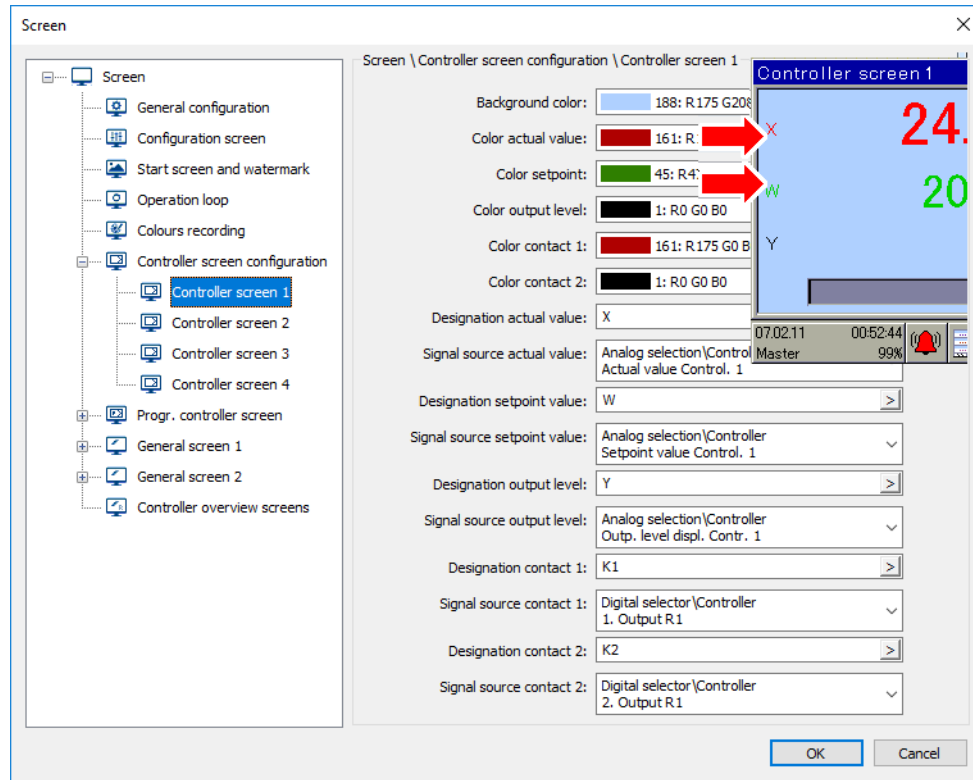

Parameters

Parameter	Selection/settings	Description
Background color		RGB color selector
Color for actual value		
Color for setpoint value		
Color for output level		
Color for heating contact		
Color for cooling contact		
Designation of actual value	15 characters	Default setting: X, actual value of controller 1
Signal source of actual value	Signal from the analog selector	
Designation of setpoint value	15 characters	Default setting: W, setpoint value of controller 1
Signal source of setpoint value	Signal from the analog selector	
Designation of output level	15 characters	Default setting: Y, output level of controller 1
Signal source of output level	Signal from the analog selector	
Designation of contact 1	15 characters	Default setting: K1, 1st output R1
Signal source for contact 1	Signal from the digital selector	
Designation of contact 2	15 characters	Default setting: K2, 2nd output R1
Signal source for contact 2	Signal from the digital selector	

12.10.7 Program controller screen

Setup dialog box

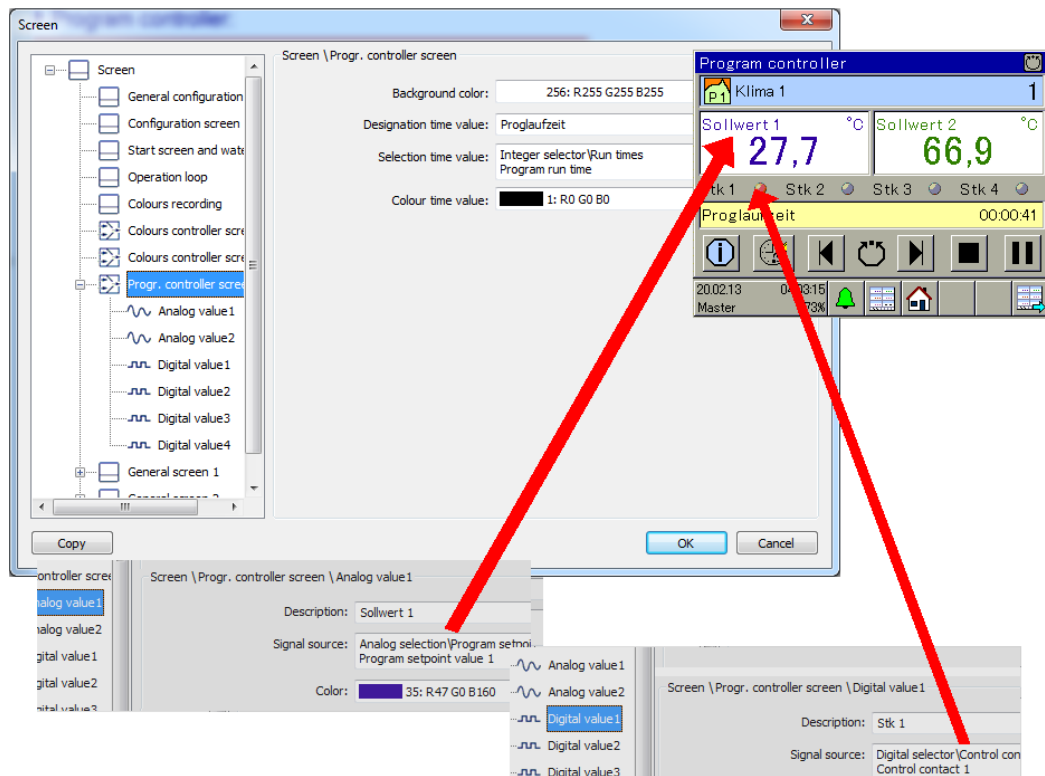

Parameters

Parameter	Selection/settings	Description
Background color		RGB color selector
Designation time value		Proglaufzeit
Signal source	No selection Analog selector (integer)	
Colour time value	R0 G0 B0	RGB color selector

Parameters for analog value 1 to 4, digital value 1 to 4

Parameter	Selection/settings	Description
Description	Sollwert1	Text for analog value 1 to 3
Signal source	No selection Analog selector	
Color	RGB color selector	Color for analog values and text
Description	Stk 1	Text for digital values 1 to 4
Signal source	No selection Digital selector	

12 Configuration

12.10.8 General screens 1, 2

Setup dialog box

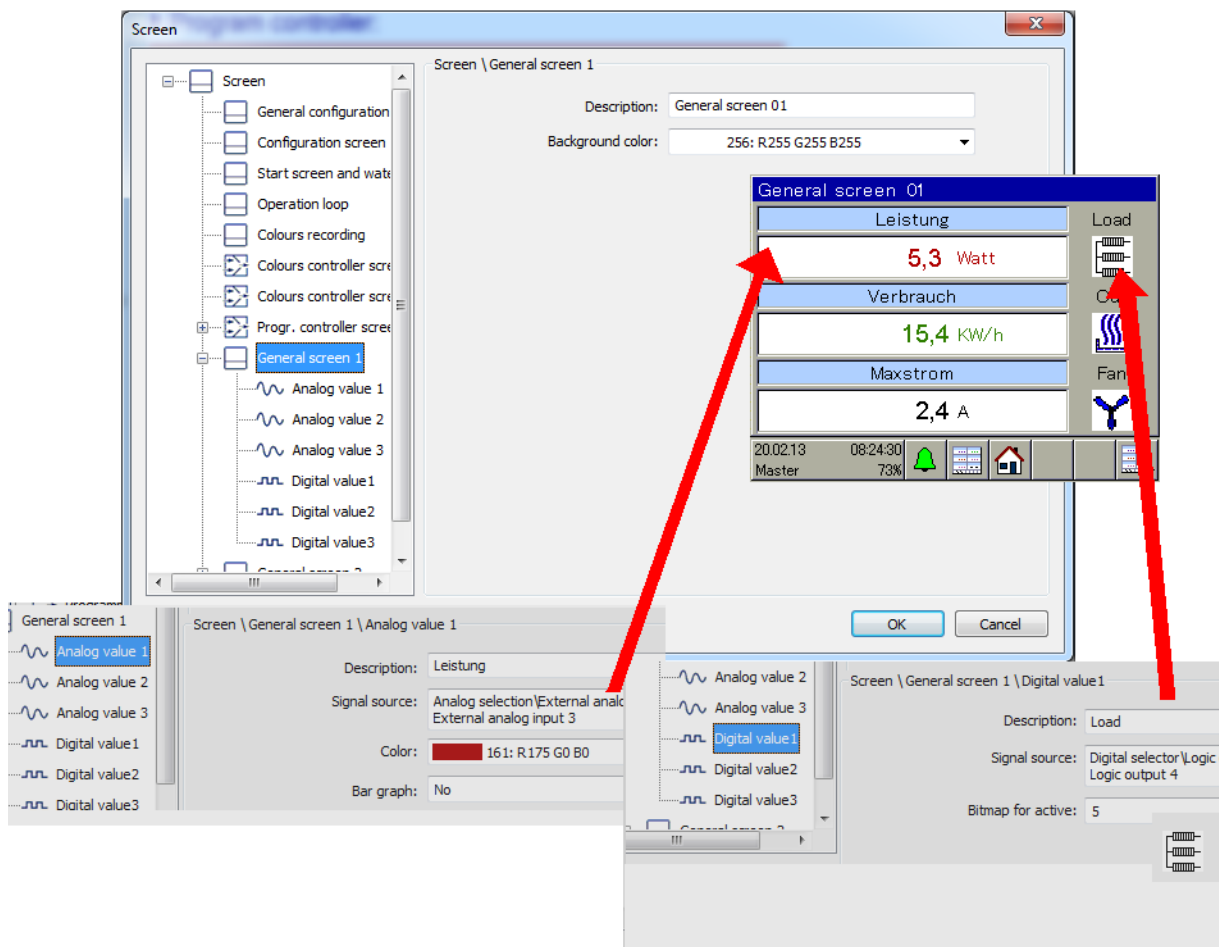

Parameters

Parameter	Selection/settings	Description
General screen	General screen 01	Text for general screen 1
Background color	(white)	RGB color selector
Description	Analog value 1 to 3	Text for analog value 1 to 3 (in light-blue box)
Signal source	No selection Analog selector	Any analog value can be displayed here
Color	RGB color selector	Color for analog values and text
Bar graph	Yes	Bar graph
	No	No bar graph
Color for bar graph	RGB color selector	Color for analog values and text
Description	Digital value 1 to 3	Text for digital value 1 to 3 (in gray area)
Signal source	No selection Digital selector	Any digital value can be displayed here

12.10.9 Controller overview screen 1, 2

Setup dialog box

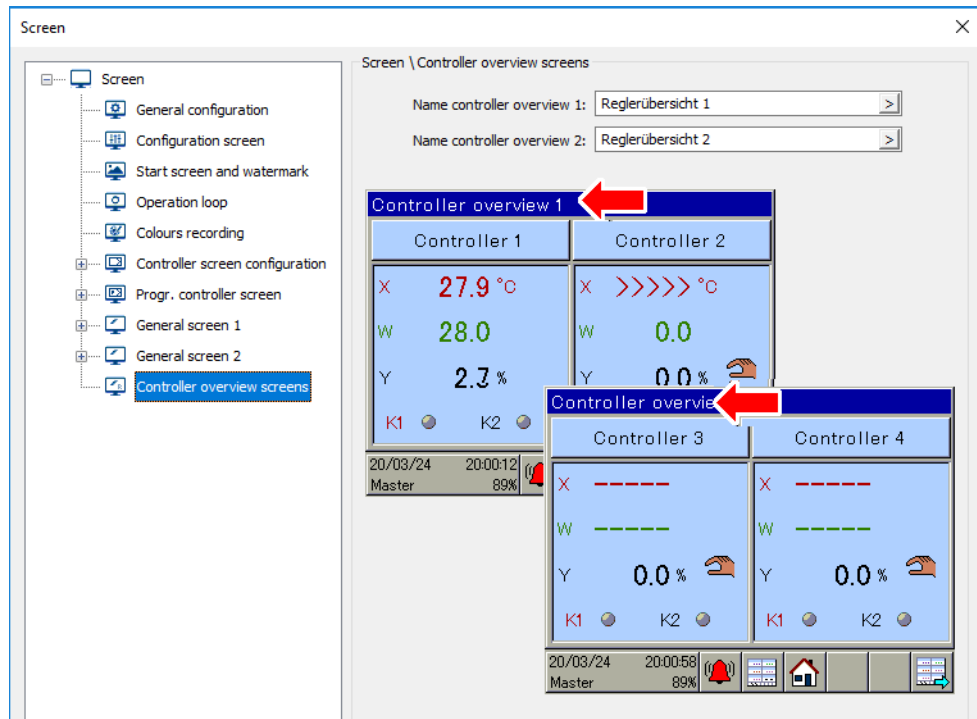

Parameters

Parameter	Selection/settings	Description
Heading for	Controller overview 1	27 characters of text can be entered
	Controller overview 2	

12 Configuration

12.11 Recording 1, 2



NOTE!

Recording is switched off per default and a maximum of 4 analog signals and a maximum of 3 digital signals are displayed in the form of a recorder screen. Activation is required for the recorded data to also be saved or extracted and processed.

⇒ Chapter 15.6 "Approval of extra codes", page 177

The appearance of the recording views can be set here.

The watermark can be adjusted here

⇒ Chapter 12.10.3 "Start screen and watermark", page 113

12.11.1 Parameters

Setup dialog box

In this example, 4 analog signals and 3 digital signals are recorded per second in group 1. In order for the recording view to appear on the device, "Anzeigen und speichern" (Display and save) must be set for the group and at least one channel must be selected.

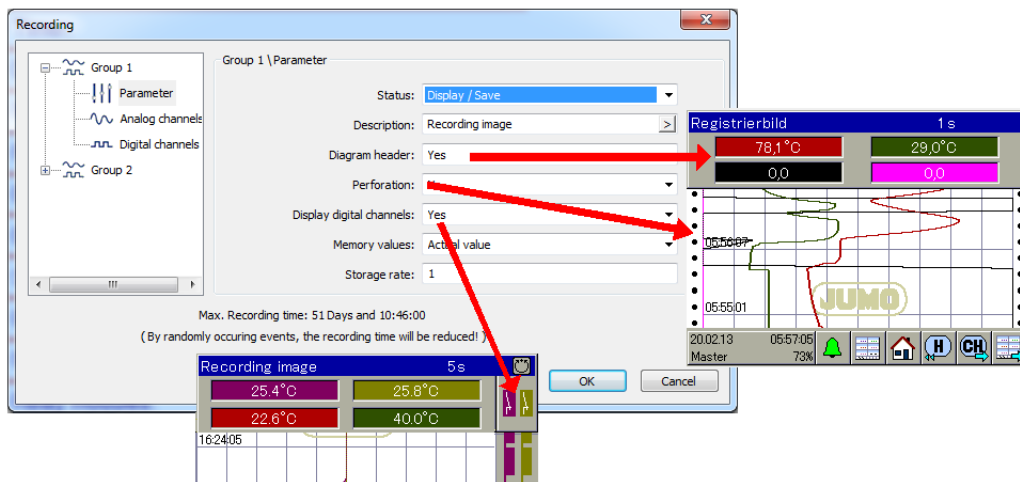

Parameters

Parameter	Selection/settings	Description
Status	Switched off	The progression of the analog and digital signals over time is first displayed on the screen and then saved.
	Display and save	
Designation	Recording view	Text for recording view
Diagram header	Yes	Numeric representations of the analog signals ⇒ Chapter 12.10.5 "Colors recording", page 115
	No	No diagram header visible
Perforation	Yes	Only visible if digital channels are switched off.
	No	No perforation visible
Display digital channels	Yes	Digital signal levels are highlighted in color.
	No	

Parameter	Selection/settings	Description
Memory values	Mean value	The mean value is calculated based on the set memory cycle and saved.
	Current value	The value at the time of scanning is saved.
	Minimum value	The minimum is determined based on the set memory cycle and saved.
	Maximum value	The maximum is determined based on the set memory cycle and saved.
Memory cycle	1 to 5 to 3600 s	A value is recorded every 5 seconds.

Updating/backing up recording data

When the recording data memory is full, the recorded data can be saved on the PC using data archiving software or exported onto a mass storage device. The USB host socket is used for this purpose.

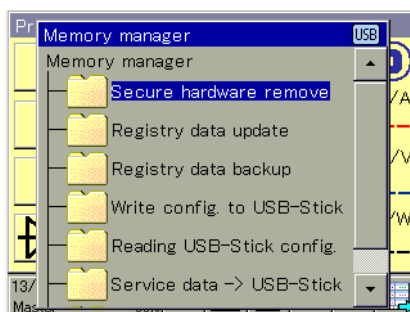

Function	Meaning
Secure hardware remove	To prevent hardware damage or loss of data, it is necessary to select this menu item before removing an inserted USB flash drive. Please follow the instructions on the device's display.
Registry data update	Measurement data that has not yet been retrieved is transferred to the flash drive together with their configuration data. The measurement data is stored in DAT files and the configuration data in SET files. These files can be opened and evaluated with the aid of the JUMO PCA3000 evaluation software. Data that has been extracted is marked internally as retrieved and the available memory display is set to 100 %.
Registry data backup	All measurement data in the ring buffer (also data already retrieved) is transferred to the flash drive together with their configuration data. The measurement data is stored in DAT files and the configuration data in SET files. These files can be opened and evaluated with the aid of the JUMO PCA3000 evaluation software. In contrast to a recorder update, the recorder data is not marked internally and the available memory display is not reset.

12 Configuration

12.11.2 Analog channels

Setup dialog box

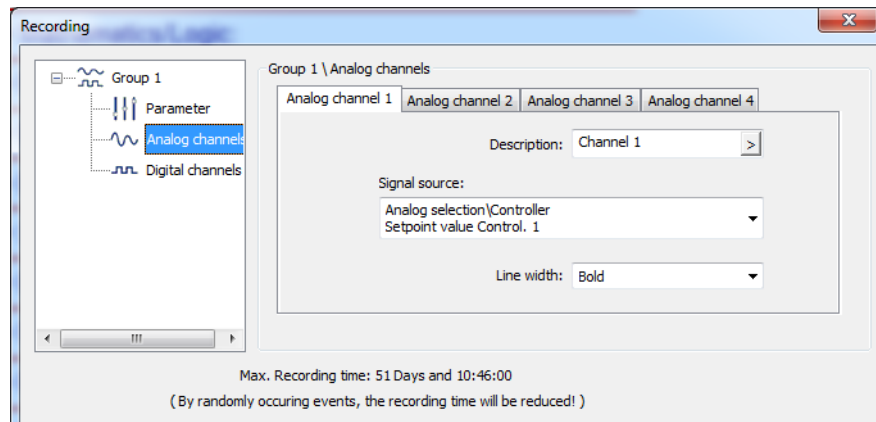

Parameters

Parameter	Selection/settings	Description
Analog signal 1 to 4		
Description	Channel 1	
Signal source	No selection Analog selector	Any analog value can be recorded here
Line width	Fine Bold	

12.11.3 Digital channels

Setup dialog box

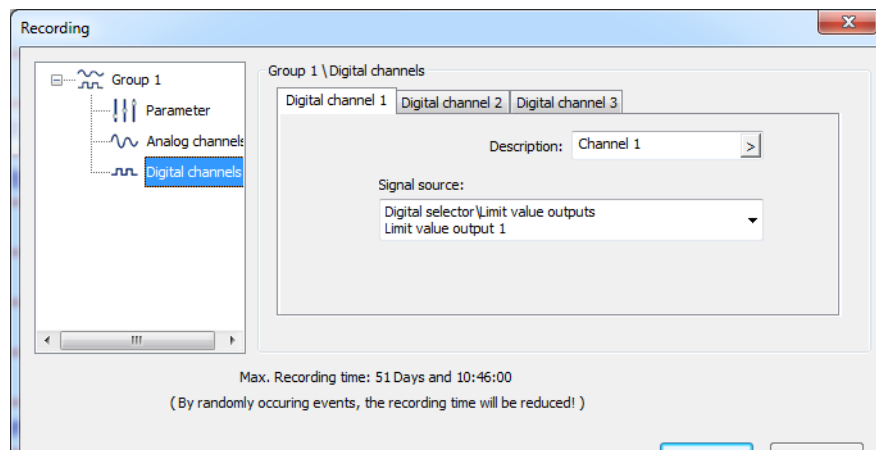

Parameters

Parameter	Selection/settings	Description
Digital signal 1 to 3		
Description	Channel 1	
Signal source	No selection Digital selector	Any digital value can be recorded here

12.12 Program controller

You can choose here between the program controller and the fixed-setpoint controller. With the fixed-setpoint controller, all program functions are deactivated and the setpoint values are switched, as described in Chapter 11.4 "Setpoint values", page 64.

Setup dialog for fixed-setpoint controller

With the fixed-setpoint controller, all additional program functions are grayed out and therefore inactive.

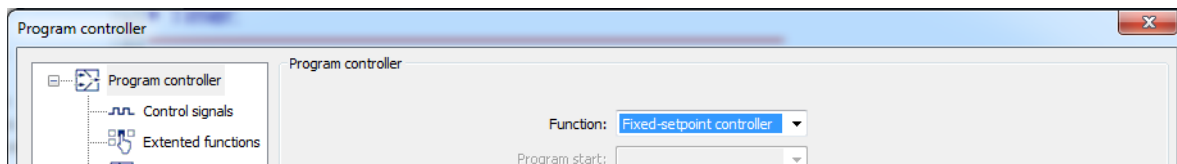

Setup dialog for program controller

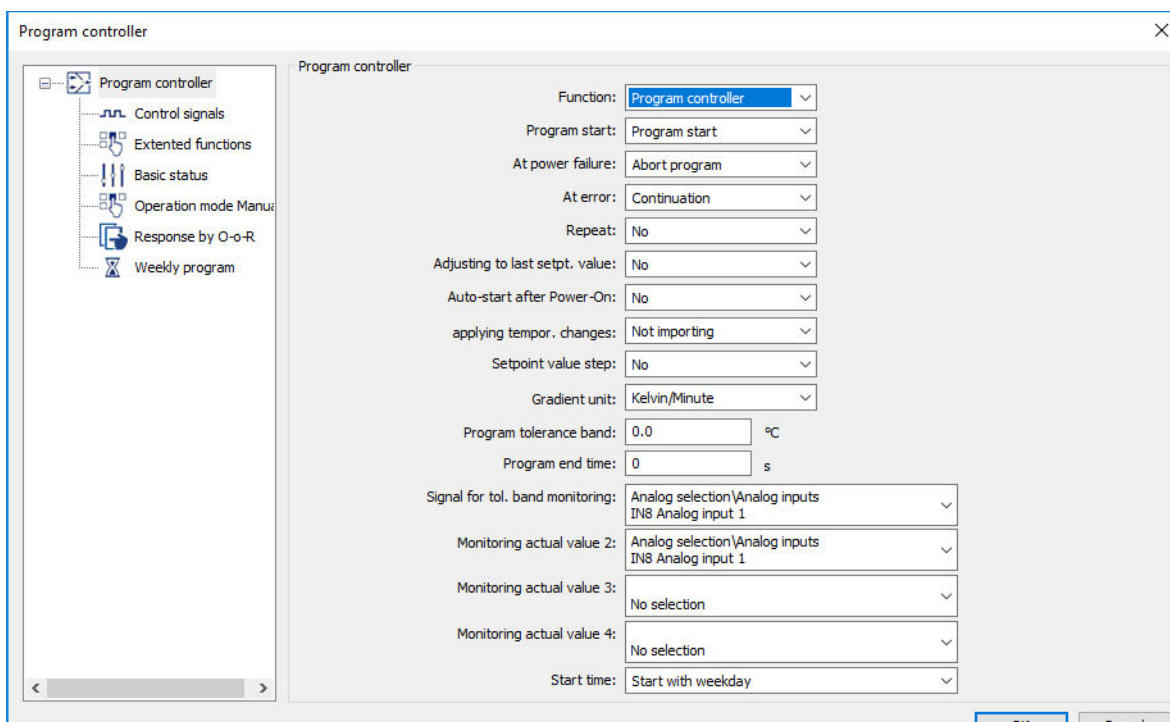

Parameters

Parameter	Selection/settings	Description
Function	Fixed-setpoint controller Program controller	All additional parameters are grayed out for this setting.
Program start	From program start Actual value Time	Program is started at the start ... at current actual value at a given time.
In the event of power failure	Abort	The program is aborted following a power failure.

12 Configuration

Parameter	Selection/settings	Description
	Continuation	After the power failure, the program continues to run from the point of disruption.
	Start at actual value	After the power failure, the program continues to run from the current actual value.
In the event of an error	Continuation	Program continues to run.
	Program stop	The time base of the program controller is stopped.
Repetition	No	No program repeat
	Yes	-
Regulate last setpoint value	No	-
	Yes	Once the power is restored, the value is set to the last setpoint value.
Start with power on	No	No automatic program start after power on.
	Yes	Automatic program start after power on.
Adopt temp. changes	No	Do not adopt temporary changes.
	Yes	Adopt temporary changes
Setpoint step	No	
	Yes	
Gradient unit	Kelvin/minute Kelvin/hour Kelvin/day	
Actual value input for tolerance band monitoring	IN8 analog input 1 Analog selector	This value is monitored by the tolerance band. ⇒ Chapter 12.6.8 "Ramp function", page 99
Signal for actual value 2	IN8 analog input 1 Analog selector	
Program tolerance band	0 to 9999	Determines the distance of the tolerance band around the program profile. 0 means switched off. The set value monitors the actual value input for tolerance band monitoring set above and checks whether it is following the program setpoint. If it leaves the tolerance band, the program flow is stopped until the actual value is back within the tolerance band.
Program end time	-1 to 0 to 9999	If -1 is entered, the program end time is therefore infinite and the device does not return to the operating loop. The program end signal in the digital selector remains active until, for example, another program is started.

12 Configuration

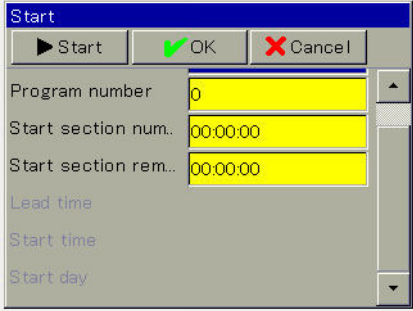
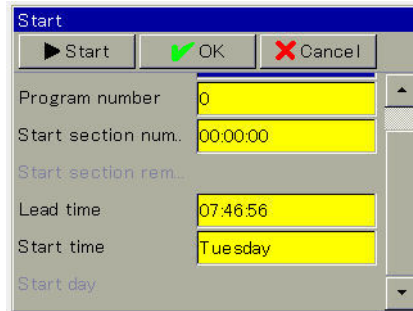
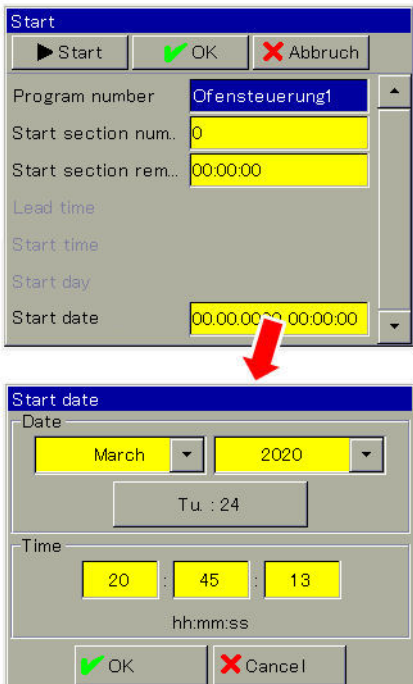
Parameter	Selection/settings	Description
Start time	Start without specific time	Program start after lead time 
	Start with day of the week	Program start on a day of the week and with a start time 
	Start with date	Program start on a specific date and at a specific time 

12 Configuration

12.12.1 Control signals

Setup dialog box

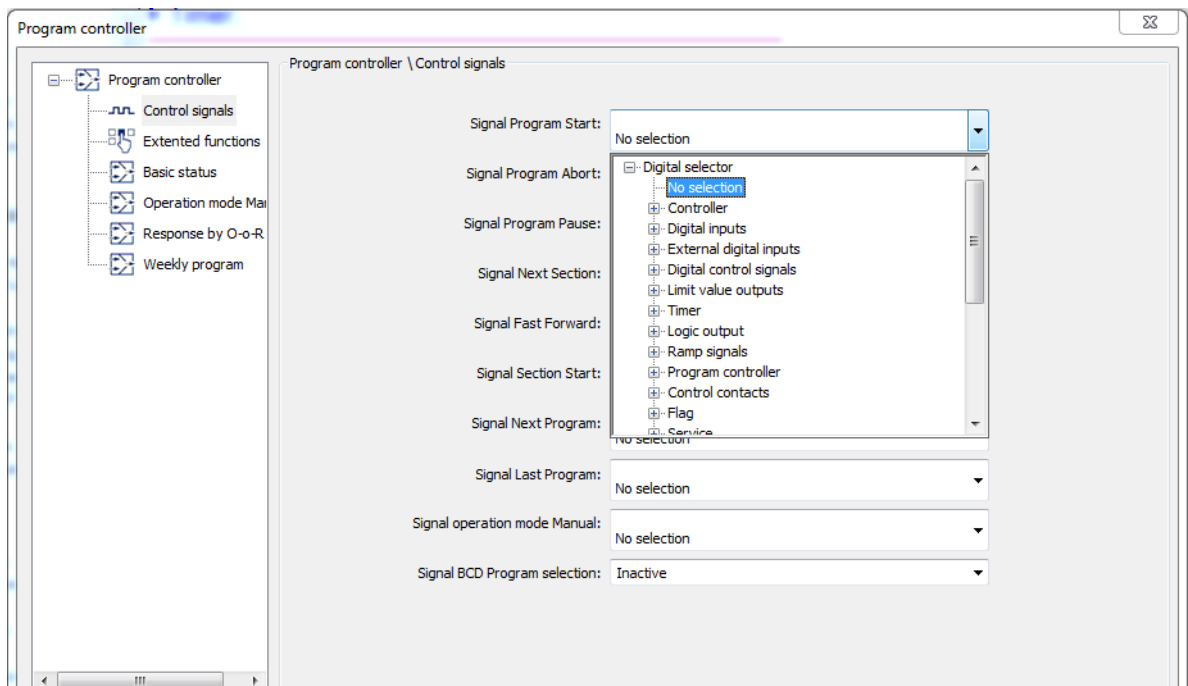

Parameters

Parameter	Selection/settings	Description
Signal Program Start	Digital selector No selection	This signal starts a program.
Signal Program Abort	Digital selector No selection	This signal aborts a program.
Signal Program Pause	Digital selector No selection	This signal stops a program.
Signal Next Section	Digital selector No selection	This signal switches to the next program section.
Signal Fast Forward	Digital selector No selection	This signal fast forwards through the programs. The longer the signal appears for, the faster the process.
Signal Section Start	Digital selector No selection	Switches back to section start.
Signal Next Program	Digital selector No selection	Start next program
Signal Last Program	Digital selector No selection	Start last program
Signal operation mode Manual	Digital selector No selection	Start manual mode
Signal BCD Program selection	Inactive	Program selection using digital control signals

Parameter	Selection/settings	Description

12.12.2 Extended functions

Setup dialog box

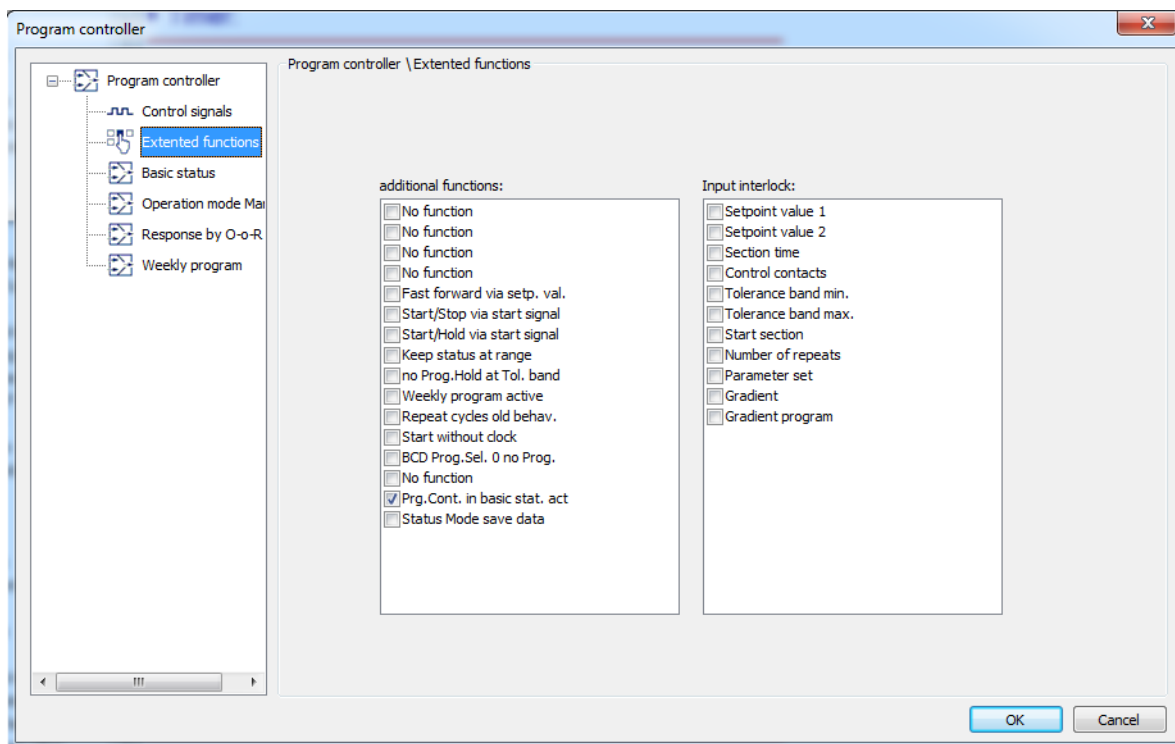

Parameters

Parameter	Selection/settings	Description
Additional functions	Not selected (empty)	-
	() No function () Fast forward etc.	Reserved functions for service
Input interlock	Not selected (empty)	-
	() Setpoint value 1 () Setpoint value 2 () Section time () Control contacts () Tolerance band min. () Tolerance band max. () Start section () Number of repeats () Parameter set	The ticked program controller functions are locked.

12 Configuration

12.12.3 Basic status

This is where settings are adjusted for what should be active in the basic status of the program controller, that is, if no program is active in automatic mode.

Setup dialog box

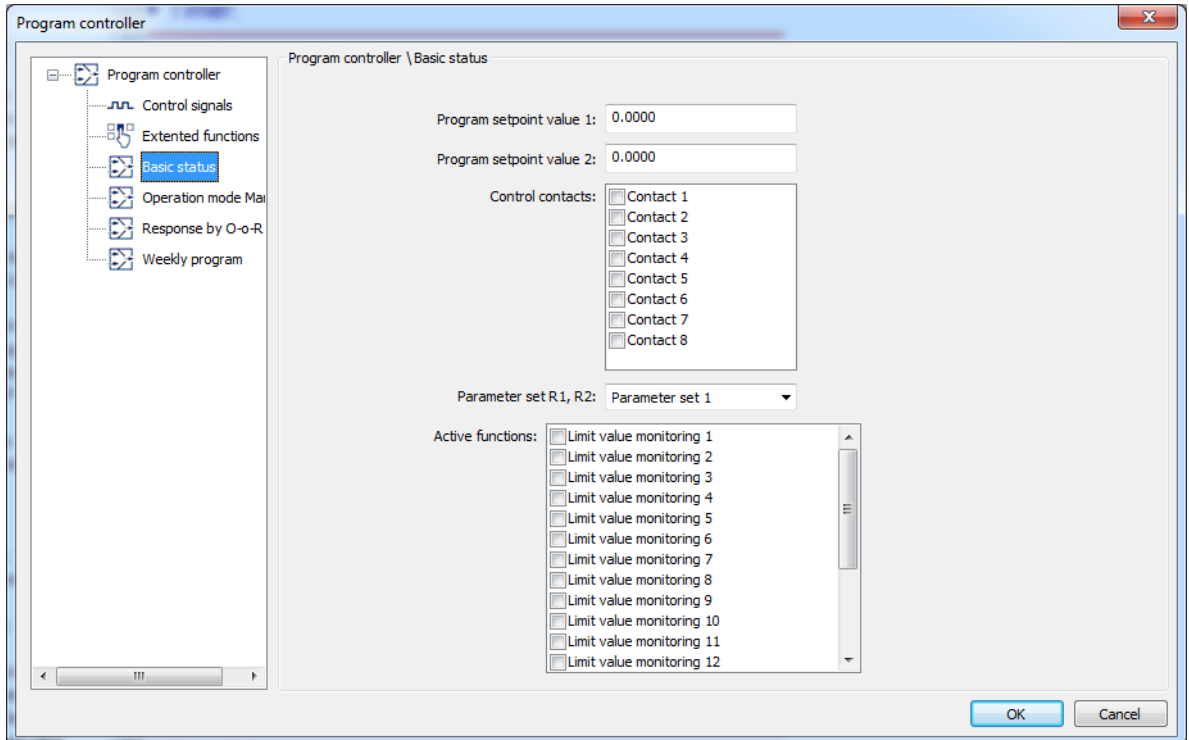

Parameters

Parameter	Selection/settings	Description
Program setpoint value 1	0.00 to 99999	The value entered here is active in the basic status.
Program setpoint value 2	0.00 to 99999	
Control contacts	Not selected (empty) () Contact 1 to 8	Ticked operating contacts are active in the basic status.
Parameter set R1/R2	Parameter block 1 to 4	The parameter block set here is active for both controllers in the basic status
Active functions	Not selected (empty) () Limit value monitoring 1 to 12 () Controller 1, 2	The ticked limit value monitoring function is active in the basic status. The ticked controller is active in the basic status

12.12.4 Operation mode Manual

You can set what is active in manual operating mode here.

Setup dialog box

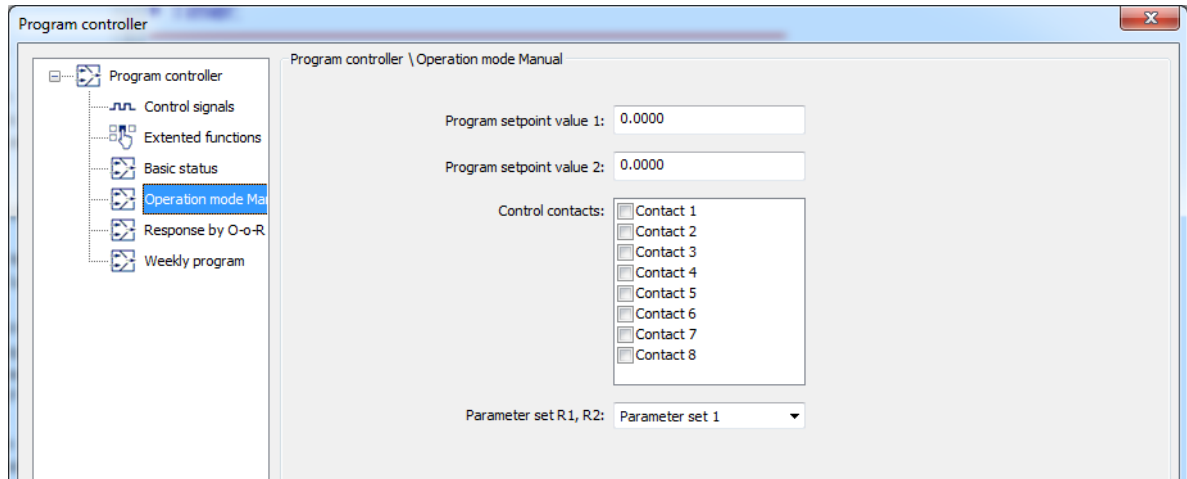

Parameters

Parameter	Selection/settings	Description
Program setpoint value 1	0.00 to 99999	The value entered here is active in manual operating mode.
Program setpoint value 2	0.00 to 99999	
Control contacts	Not selected (empty) () Contact 1 to 8	Ticked operating contacts are active in manual operating mode.
Parameter set R1/R2	Parameter block 1 to 4	The parameter block set here is active for both controllers in manual operating mode

12 Configuration

12.12.5 Response by out of range (O-o-R)

Here you can set which parameters should be active in the program controller in the event of a deviation above or below the measuring range.

Setup dialog box

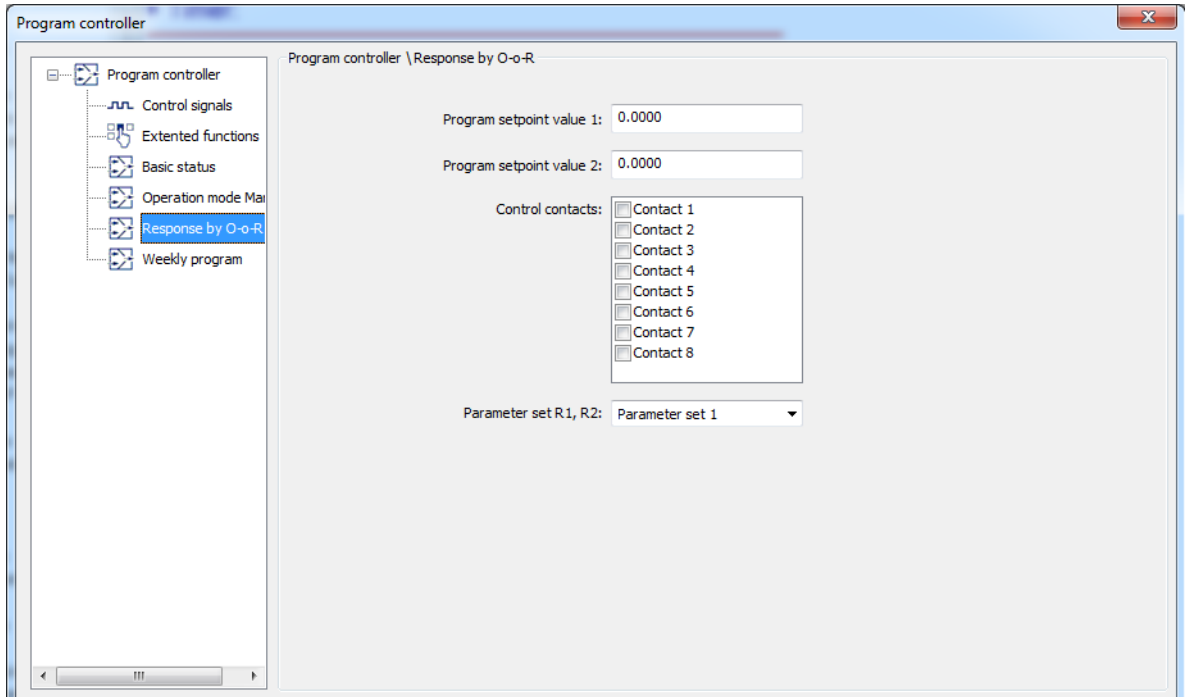

Parameters

Parameter	Selection/settings	Description
Program setpoint value 1	0.00 to 99999	The value entered here is active for out of range parameters.
Program setpoint value 2	0.00 to 99999	
Control contacts	Not selected (empty) () Contact 1 to 8	Ticked operating contacts are active if out of range applies.
Parameter set R1/R2	Parameter block 1 to 4	The parameter block set here is active for both controllers if out of range applies

12.12.6 Weekly program

10 different weekly programs can be defined here.

Setup dialog box

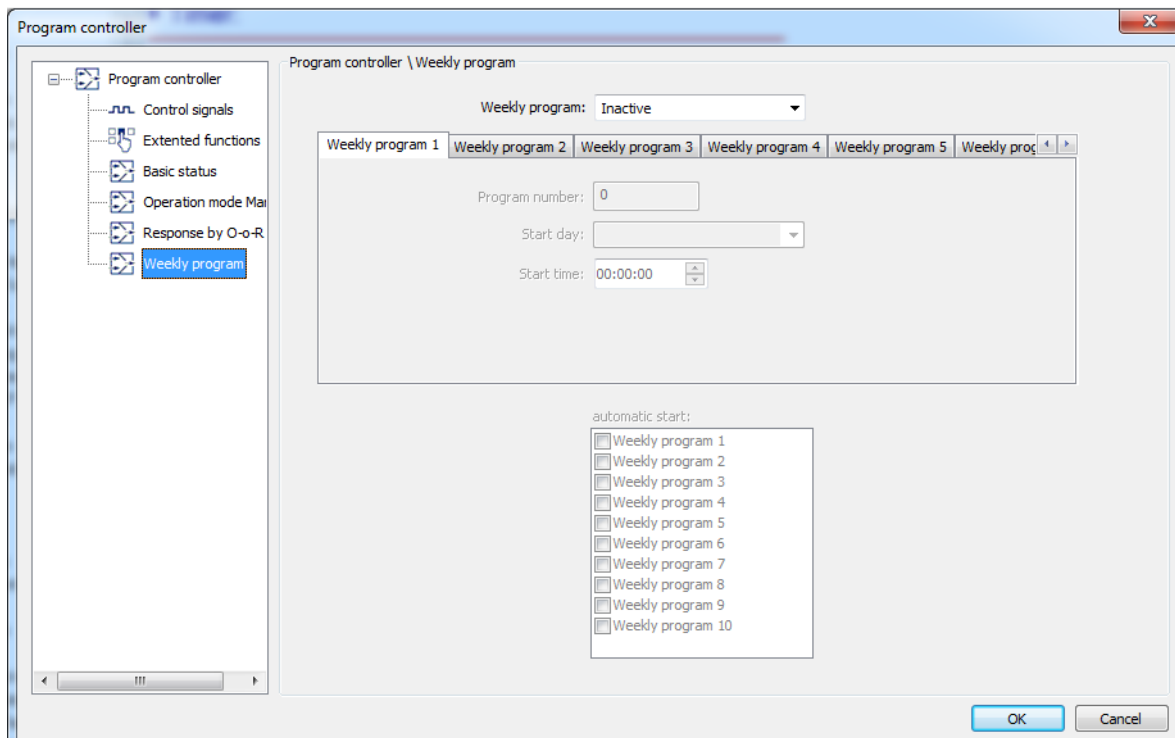

Parameters

Parameter	Selection/settings	Description
Automatic start	Not selected (empty) () Weekly program 1 to 10	Ticked weekly programs start automatically
Weekly program 1	Program number: 0 Program number: 1 Start day: Sunday Start time: 1	Inactive Number of program to be started Program starts on this day Program starts at this time
Weekly program 2 to 10	Program number Start day Start time	Number of program to be started Program starts on this day Program starts at this time

12 Configuration

12.13 Timer or week-time switch

4 functions are available that can be used as a timer or week-time switch. The settings can be copied to another timer using the **COPY** button.

Setup dialog for timer

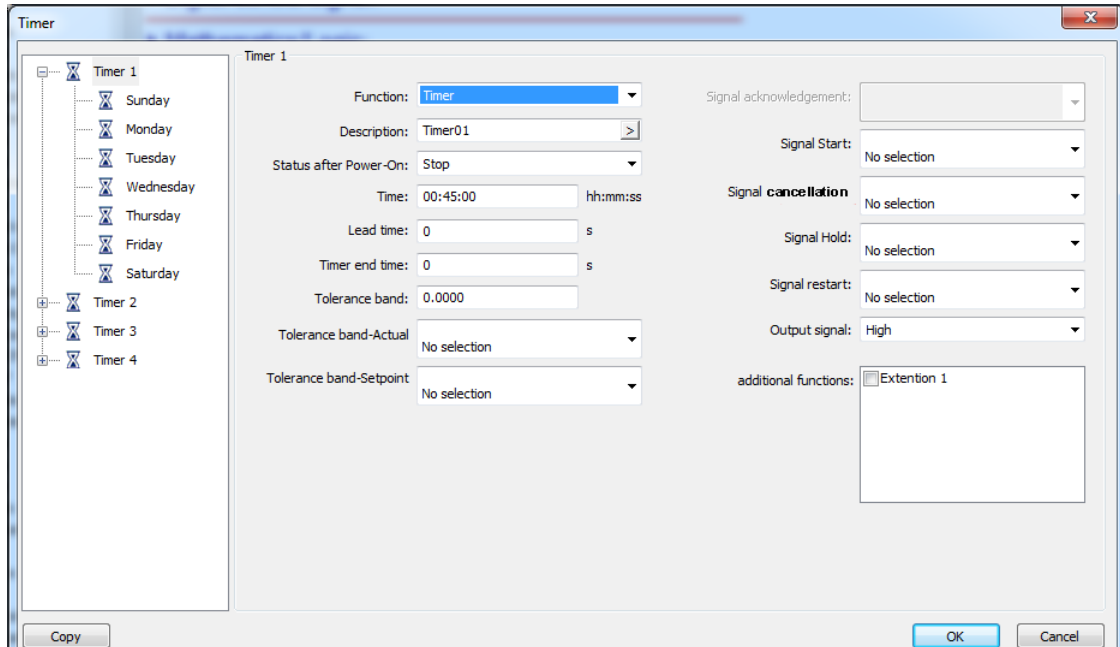

Parameters

Parameter	Selection/settings	Description
Function	Inactive	-
	Timer	Timer function active, week-time switch grayed out
Designation	Timer 01	(15 characters) of editable text
Behavior after power on	Stop	The timer is stopped after a power failure.
Lead time	0 to 9999	Lead time until the timer is started
Timer time	00:00:00 to 99:59:59	The timer works for this time period
Timer end time	0 to 9999	Downstream timer that is also available in the digital selector (timer end signal). ⇒ Chapter 12.2 "Digital selector", page 68
Tolerance band	0.0000 to 99999	If the distance between the tolerance band setpoint and actual values still lies within the tolerance band, the timer output signal is low (logic level 0).
Tolerance band actual value	Analog selector	These values are compared with one another: If the setpoint and actual values lie so far apart from one another that they exceed the tolerance band, the timer stops and the timer output signal changes to high (logic level 1).
	No function	
Tolerance band setpoint value	Analog selector	
	No function	

Parameter	Selection/settings	Description
Acknowledgement signal		A timer alarm is acknowledged with this signal.
Start signal	Digital selector No function	The timer is started with this signal
Cancel signal	Digital selector No function	The timer is canceled with this signal
Halt signal	Digital selector No function	The timer is halted with this signal.
Restart signal	Digital selector No function	
Output signal	High Low	The signal level for the active timer is set here. This signal is available in the digital selector for further use.
Additional timer functions	Not selected (empty) () Extension 1	Reserved functions for service

Setup dialog for week-time switch

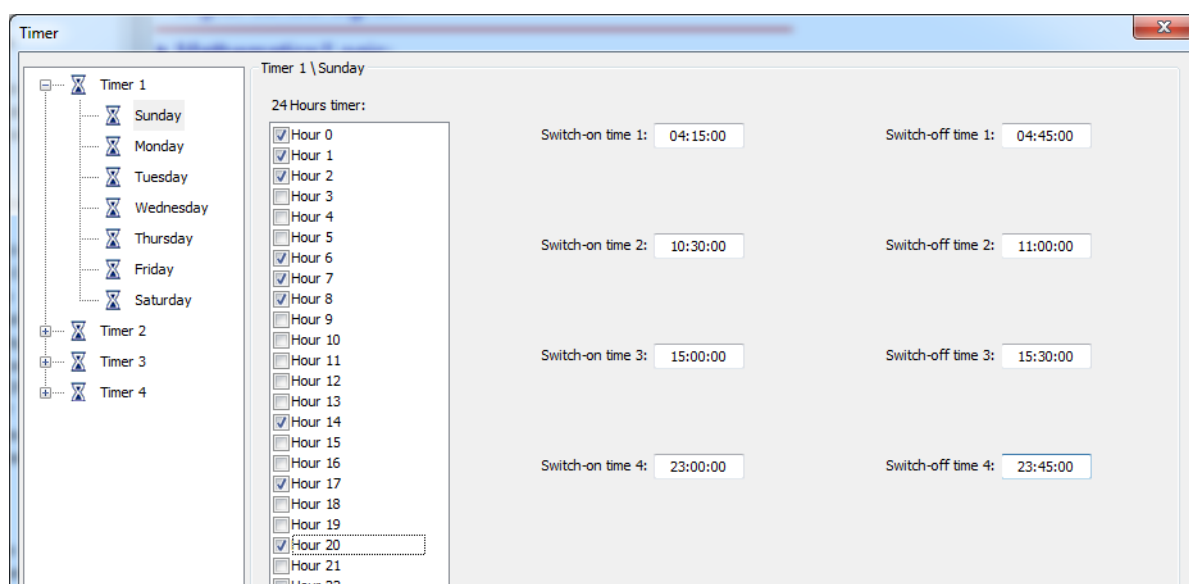

Parameters

Parameter	Selection/settings	Description
Function	Inactive	-
	Control timer	Week-time switch active, timer function grayed out
Sunday	Hours 0 to 24 ()	The period of time for which the week-time switch should be active on this day can be selected in hour units here by ticking the relevant box ("High": logic level 1).
	Switch-on time 1 to 4 Switch-off time 1 to 4	4 additional switch times can be set here, for example if the switch-on time period should be less than a full hour.

12 Configuration

Parameter	Selection/settings	Description
Monday to Saturday	Hours 0 to 24 ()	Same settings possible as for Sunday
	Switch-on time 1 to 4	
	Switch-off time 1 to 4	

12.14 Digital controller signals

A maximum of 8 unrelated links with up to four signals each (digital selector) can be configured. Use the **COPY** button to transfer the settings of the selected link to another link and to then make changes there as desired.

The result of a link is available in the digital selector.

Setup dialog box

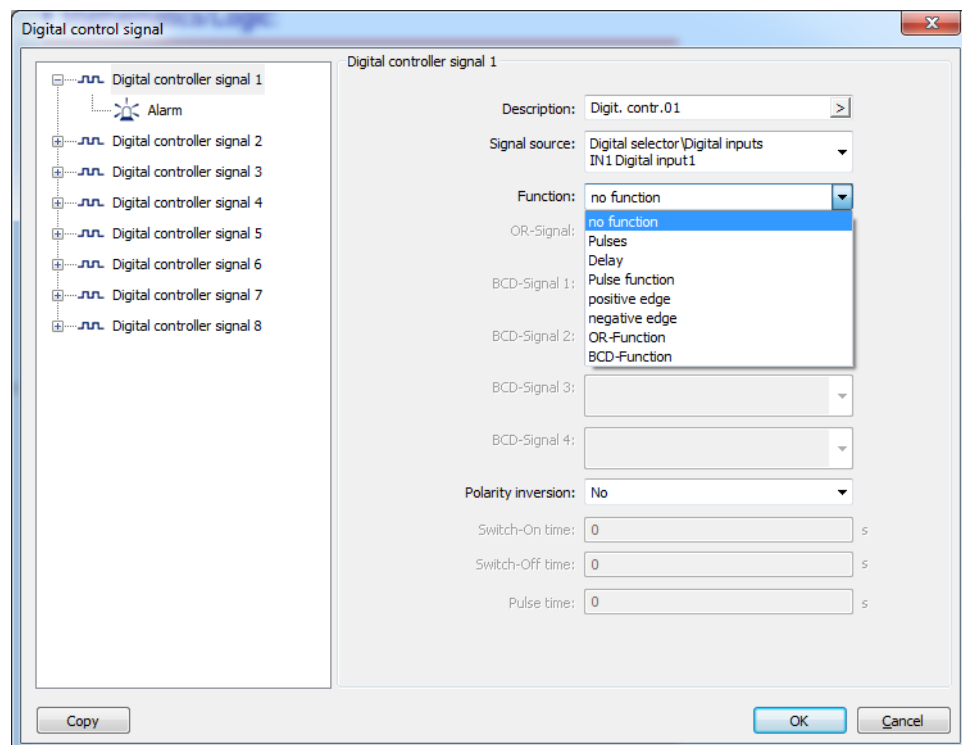

Parameters

Parameter	Selection/settings	Description
Description	Digit. contr. 01	(15 characters) of editable text
Signal source	No selection Digital selector	Any digital value that should be linked with a function
Function	No function Pulses Delay Pulse function Positive edge Negative edge OR function BCD function	-
OR-Signal	No selection Digital selector	Any digital value that should be linked to a signal source above using an OR operator
BCD-Signal 1	No selection Digital selector	1st BCD digital value

12 Configuration

Parameter	Selection/settings	Description
BCD-Signal 2	No selection Digital selector	2nd BCD digital value
BCD-Signal 3	No selection Digital selector	3rd BCD digital value
BCD-Signal 4	No selection Digital selector	4th BCD digital value
Polarity inversion	No Yes	-
Switch-On time	0	For example, if the signal set under the signal source is to be delayed
Switch-Off time	0	
Pulse time	0	For example, if the signal set under the signal source has a pulse function

Function

The following screen shows an OR function for digital inputs 1 and 2, which is issued from digital output OUT2

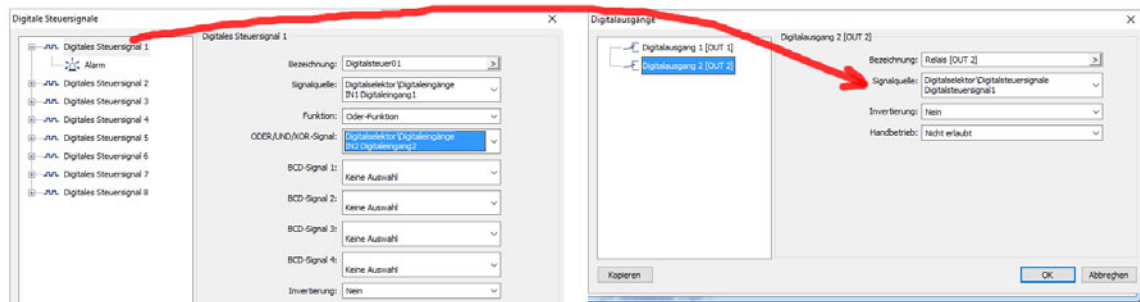

BCD signal

With the BCD function (Binary Coded Decimal), 4 digital signals (4-bit) can be processed into one digital controller signal, for example, one that can switch between 16 different programs.

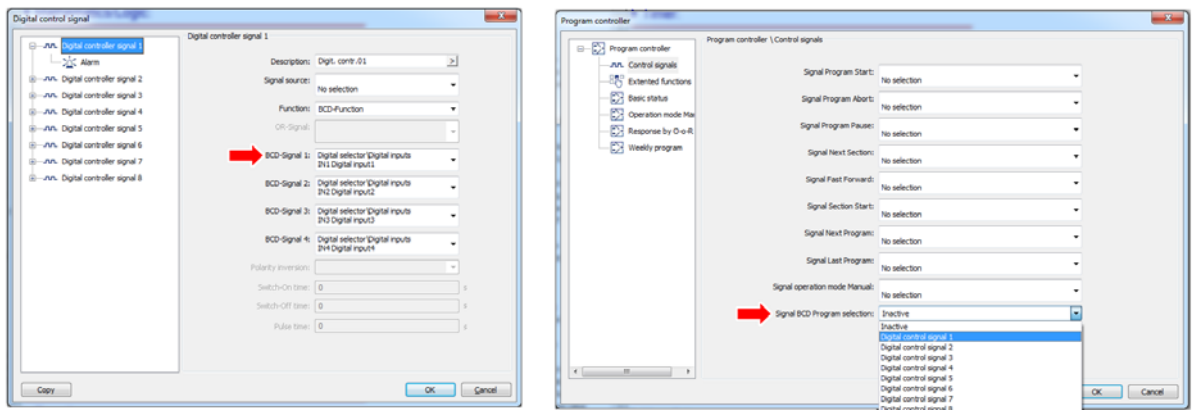

12.14.1 Alarms

Setup dialog box

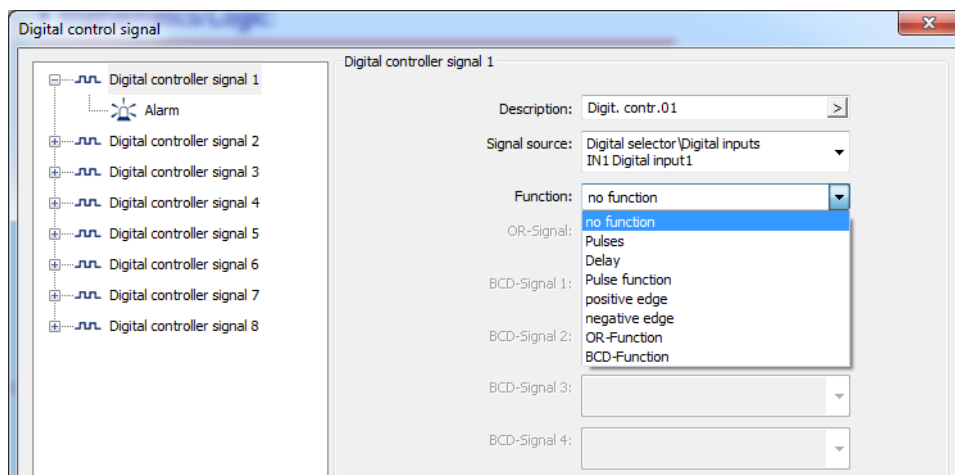

Parameters

Parameter	Selection/settings	Description
Alarm type	Off	Alarm switched off.
	Alarm	A message will be entered in the alarm list depending on the signal level that has been set.
	Event	A message will be entered in the event list depending on the signal level that has been set.
Alarm active at	Signal level that triggers an alarm or event	
(setup only)	High	Digital control signal: High (logic level 1)
	Low	Digital control signal: Low (logic level 0)
Alarm text (only setup) 	Alarm digital control 01	20 characters of editable text which is entered into the alarm or event list.

Alarm active at

An alarm is only displayed for as long as the digital control signal is High (logic level 1). If the signal level becomes Low (logic level 0), the alarm entry disappears automatically.

Alarm text

The setup program is required to view and edit the texts.

12 Configuration

12.15 Math/logic

The device provides only limited functionality.

Programming, for example of formulae, can be done more conveniently using the setup program:

16 entries for math/logic are available. Math and logic formulae 1 to 8 and 9 to 16 can be enabled as an optional extra. The functions for the differential, ratio, and relative humidity are free of charge. The optional math/logic function supports four formulae, which can be used freely either for mathematical calculations (analog values) or for logical links (binary values). The fixed formulae for calculating the differential, ratio, and relative humidity are free of charge. In this case, two analog values (variable A and B), for example, the measured values of analog input 1 and 2 are linked to each other. The dry-bulb temperature and the wet-bulb temperature are required for calculating the relative humidity and should be determined with a psychrometric humidity sensor.

The results are available in the analog selector or digital selector. If the function is not active, the mathematical value = 3.0E+37 and the logic value = 0 (FALSE). The settings can be copied to another math/logic function using the **COPY** button.

Setup dialog box

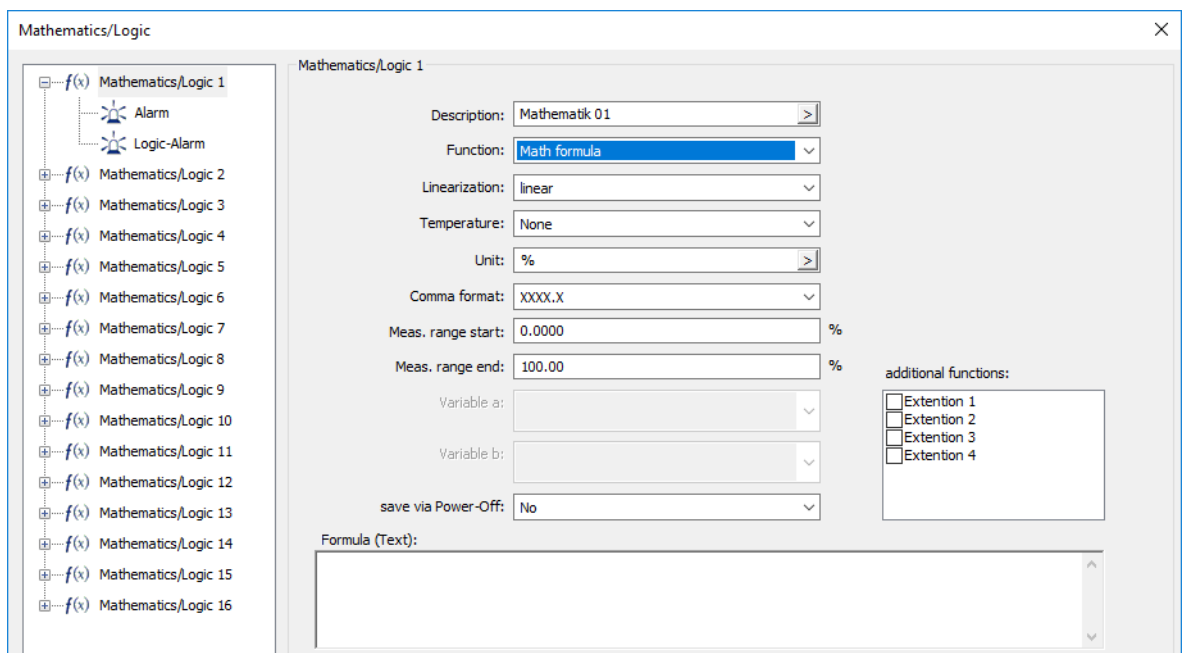

Parameters

Parameter	Selection/settings	Description
Designation	Config Math 1 to 16 (inactive)	Name of the mathematical function available as a variable in the analog selector for further processing.
Function	Inactive Differential Ratio Humidity Math formula Logic formula	Differential controller (a-b) Ratio controller (a/b) Humidity controller (a;b) Mathematical link (a+b) x 2 Logical link (a AND b)

Parameter	Selection/settings	Description
Linearization		The mathematical calculation can be linked with a (customer-specific) linearization table.
Secure using power off		
Measuring range start	0	
Measuring range end	100.00	
Variable a		
Variable b		
Unit	%	
Decimal place		
Temperature		
Additional math functions		Reserved functions for service
Formula (text)		

Function

The math and logic functions are available if the "Math/logic" option in the setup program has been activated.

Math formula, logic formula

Use the "Formula editor" button to open an editor that can be used to create formulae by selecting variables and operators. Formulas can be entered freely in line with standard mathematical rules. Any number of spaces may be used within the formula symbol string. Spaces are not admissible in function designations, names of variables, or constants.

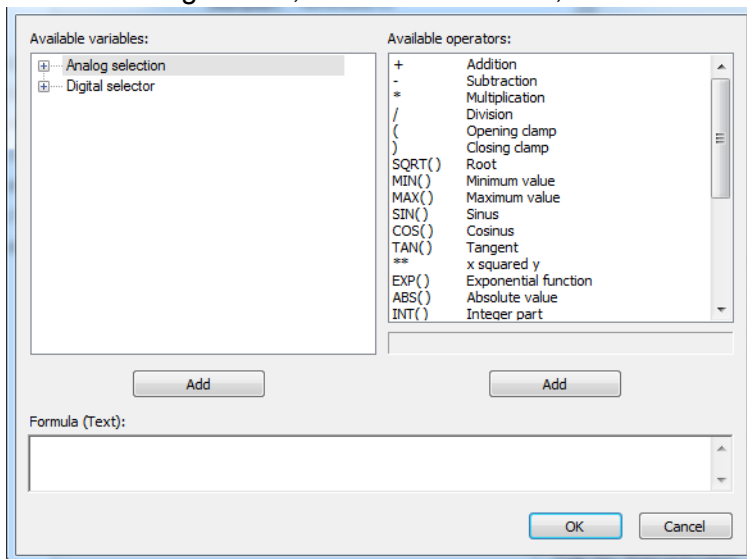

12 Configuration

12.16 Flags/service

12.16.1 Flags

8 analog flags and 8 digital flags are available. The settings can be copied to another flag using the COPY button.

Setup dialog box

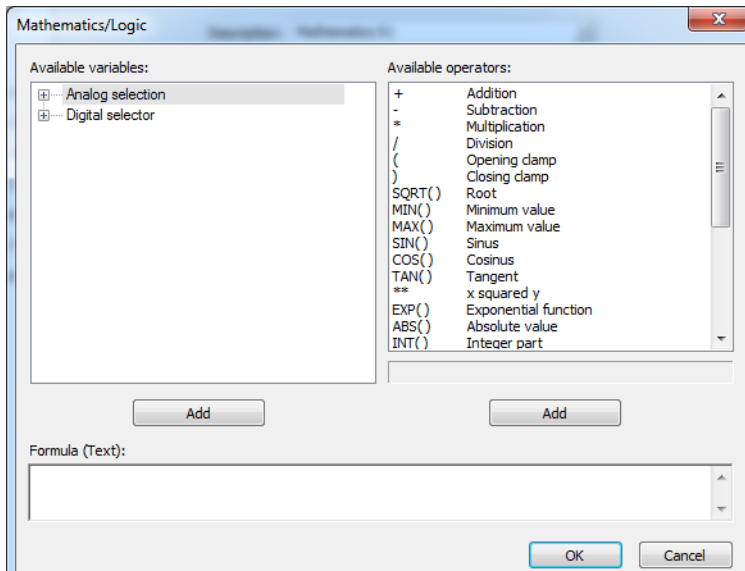

Analog flag parameters

Parameter	Selection/settings	Description
Analog flag	0.0000 to 100	Can be set within the limits to any value with 4 decimal places.
Temperature	None	
	Relative	
	Absolute	
Unit	%	Unit with up to 5 characters can be entered
Decimal place	Auto	Automatic switching
	XXXXX.	No decimal place
	XXXX.X	1 decimal place
	XXX.XX	2 decimal places
	XX.XXX	3 decimal places
	X.XXXX	4 decimal places
Measuring range start	0.0000 to 100	
Measuring range end	0.0000 to 100	

Digital flag parameters

Parameter	Selection/settings	Description
Digital flags 1 to 8	Off	Low (logic level 0)
	On	High (logic level 1)

12.16.2 Service

Here you can set which signal should be monitored, for example with a service counter. This can trigger an alarm if exceeded and can be acknowledged with the set signal.

Setup dialog box

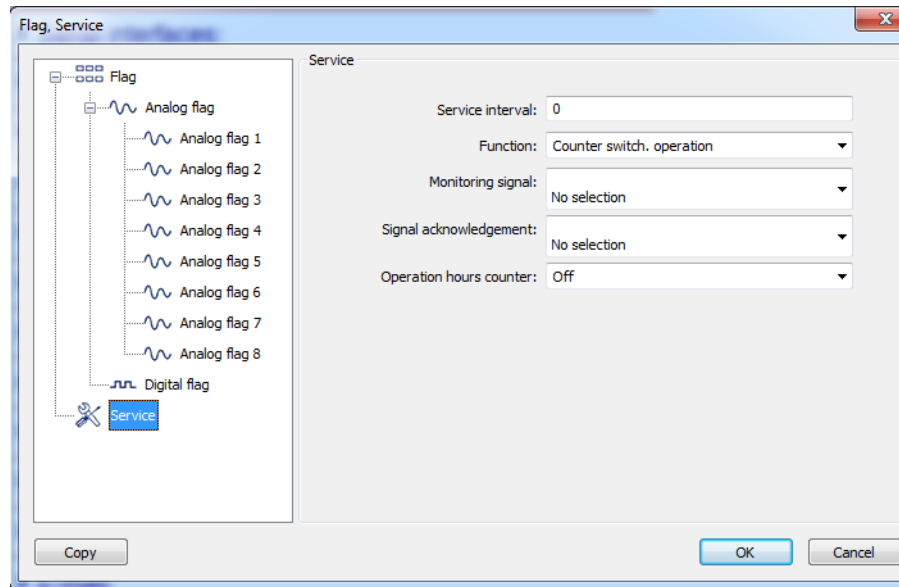

Parameters

Parameter	Selection/settings	Description
Service interval	0 to 99999	The number of switching operations for the set digital signal are counted.
Function	Counter switch. operation	Switching operations are counted
	Time in hours	The hours in which the signal was High (logic level 1) are counted.
	Time in days	The days in which the signal was High (logic level 1) are counted.
Monitoring signal	No selection Digital selector	This signal is monitored based on the service and if the alarm condition is exceeded (for example, the number of switching operations), the logic level switches from "0" to "1". The signal can be processed further in the digital selector.
Signal acknowledgement	No selection Digital selector	The elapsed service interval is acknowledged with this signal.
Operation hours counter	Off Display in hours Display in days	

12 Configuration

12.17 External digital inputs

8 external digital inputs are available. The settings can be copied to another input using the **COPY** button. The settings can be copied to another external input using the **COPY** button.

Setup dialog box

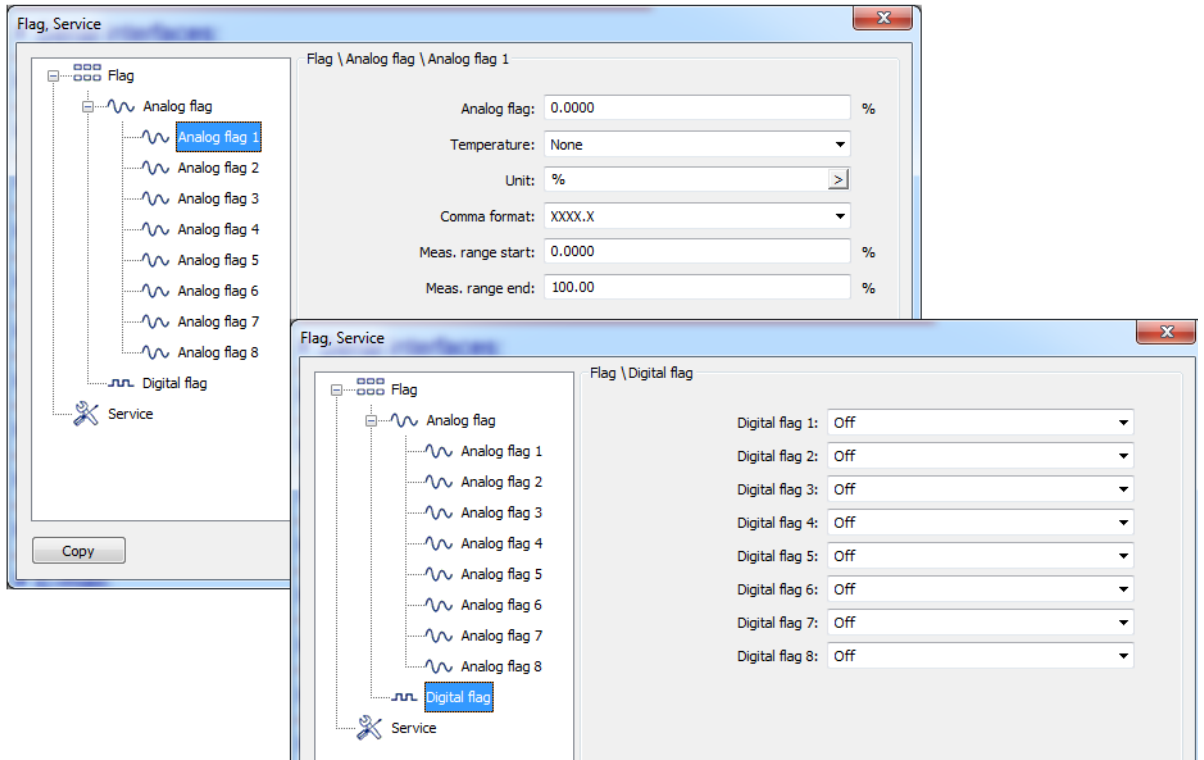

Parameters

Parameter	Selection/settings	Description
Channel description	ext. DE 01	
Save Power-OFF	No Yes	- Status is saved beyond the power failure.
Alarm type	Off	
Alarm active at		
Alarm text	Ext. digital alarm 01	

12.18 External analog inputs

8 external analog inputs are available. The settings can be copied to another input using the COPY button.

Setup dialog box

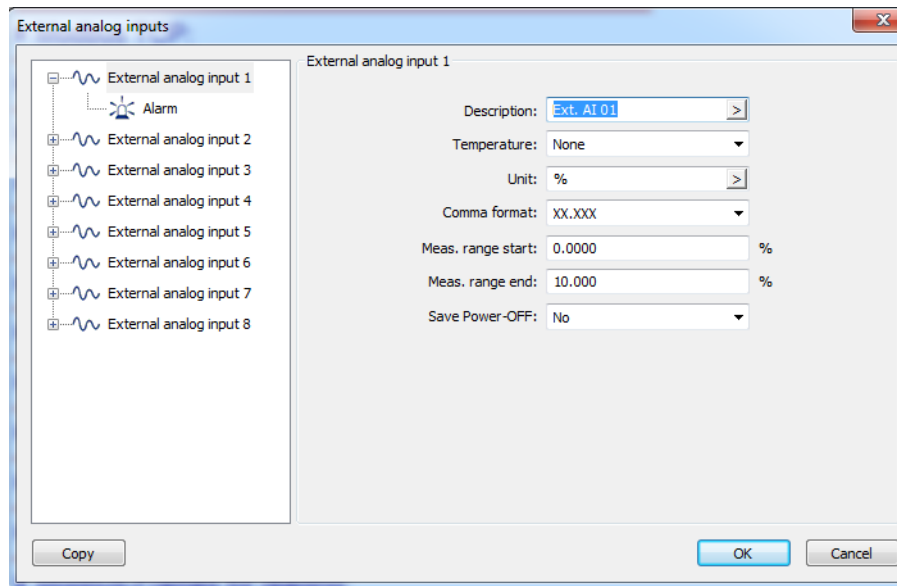

Parameters

Parameter	Selection/settings	Description
Description	Ext. AI 01	
Temperature	None Relative Absolute	
Comma format	Auto XXXXX. XXXX.X XXX.XX XX.XXX X.XXXX	Automatic switching No decimal place 1 decimal place 2 decimal places 3 decimal places 4 decimal places
Meas. range start	0.0000	
Meas. range end	100.00	
Save Power-OFF	No Yes	Status is saved beyond the power failure.

12 Configuration

12.18.1 Alarms

Setup dialog box

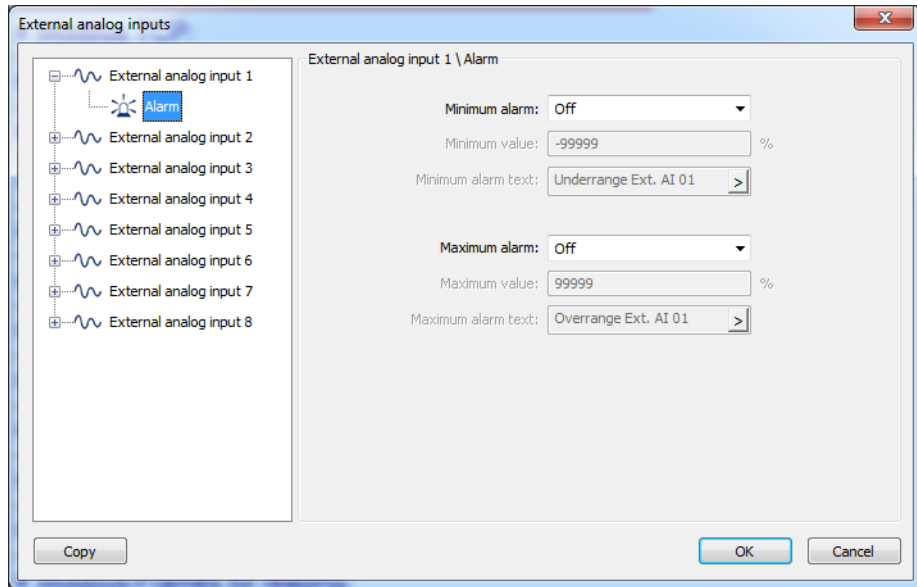

Parameters

Parameter	Selection/settings	Description
Minimum alarm	Off	Alarm switched off.
	Alarm	A message will be entered in the alarm list depending on the minimum value that has been set.
	Event	A message will be entered in the event list depending on the minimum value that has been set.
Minimum value	-99999 to 99999	In the event of deviation below the limit values, an alarm/event will be entered.
Minimum alarm text	Underrange Ext. AI 01	20 characters of editable text
Maximum alarm	Off	Alarm switched off.
	Alarm	A message will be entered in the alarm list depending on the maximum value that has been set.
	Event	A message will be entered in the event list depending on the maximum value that has been set.
Maximum value	-99999 to 99999	In the event of deviation above the limit values, an alarm/event will be entered.
Maximum alarm text	Overrange Ext. AI 01	20 characters of editable text

12.19 Serial interfaces

1 serial interface is available per default. If additional serial interfaces should be added in the form of optional boards, they will appear here.

Setup dialog box

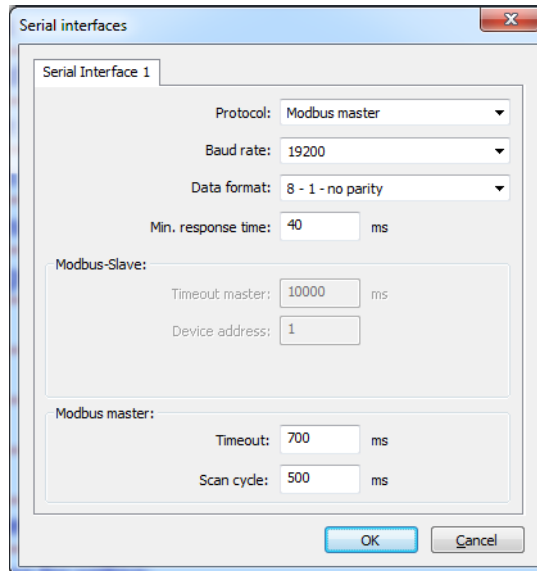

Parameters

Parameter	Selection/settings	Description
Protocol	Modbus slave	
	ER8	
	Modbus master	
Baud rate	9600, 19200, 38400	
Data format	8 - 1- no parity	
Min. response time	0 to 40 to 500 ms	Minimum response time required.
Timeout master	60 to 10000 to 60000	
Device address	1 to 254	
Timeout	60 to 700 to 10000	
Scan cycle	60 to 500 to 99999	

12 Configuration

12.20 Ethernet

This dialog only appears if an Ethernet interface is installed in the device, and it determines how the IP address is to be assigned and what the DNS server is called.

⇒ Chapter 15.2 "Ethernet (option)", page 175

Setup dialog box

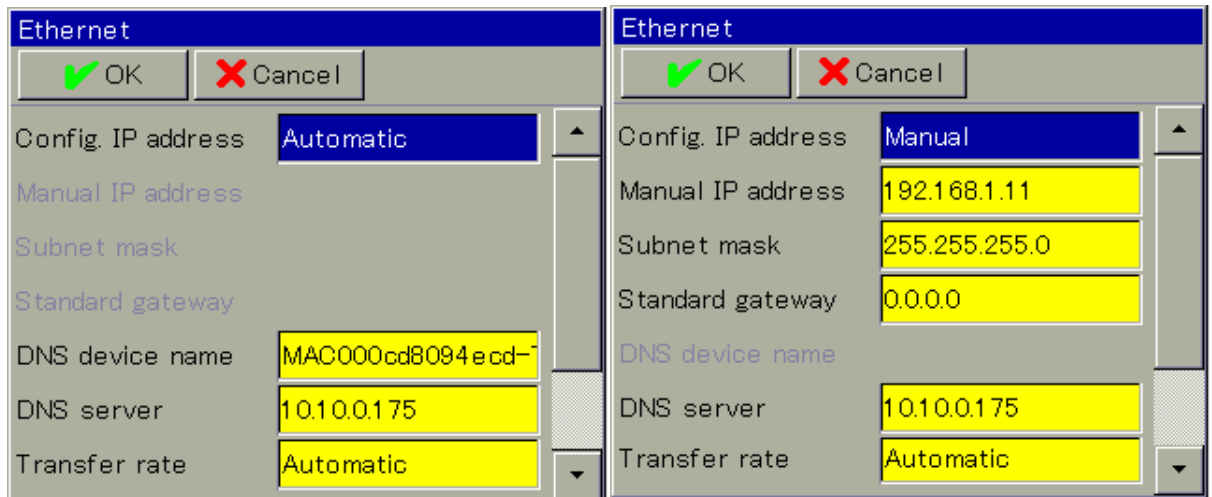

12.21 Modbus/TCP

There is no Modbus/TCP interface available per default. If it has been integrated into the device using optional boards, the following values can be set for Modbus communication:

Setup dialog box

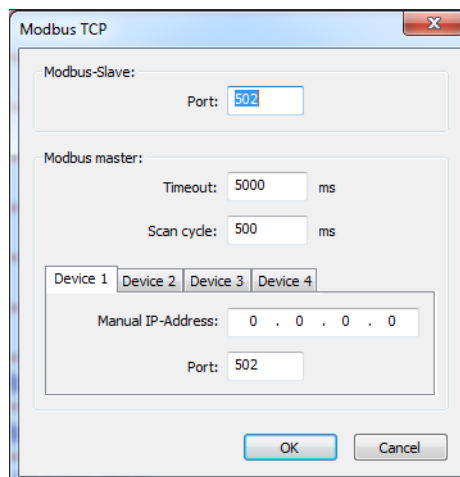

Parameters for Modbus slave

Parameter	Selection/settings	Description
Port	0 to 502 to 1024	

Parameters for Modbus master

Parameter	Selection/settings	Description
Timeout	4000 to 5000 to 10000	
Scan cycle	0 to 500 to 1024	
Device 1	0.0.0.0 to 255.255.255.255	
Device 2	0.0.0.0 to 255.255.255.255	
Device 3	0.0.0.0 to 255.255.255.255	
Device 4	0.0.0.0 to 255.255.255.255	
Manual IP-Address	0.0.0.0 to 255.255.255.255	
Port	0 to 502 to 1024	

12 Configuration

12.22 Relay module (accessories)

An external relay module or logic module ER8 can be connected to the serial interface COM1. Relays 1 to 8 are controlled using the digital selector. The relay module is inactive per default:

Setup dialog box

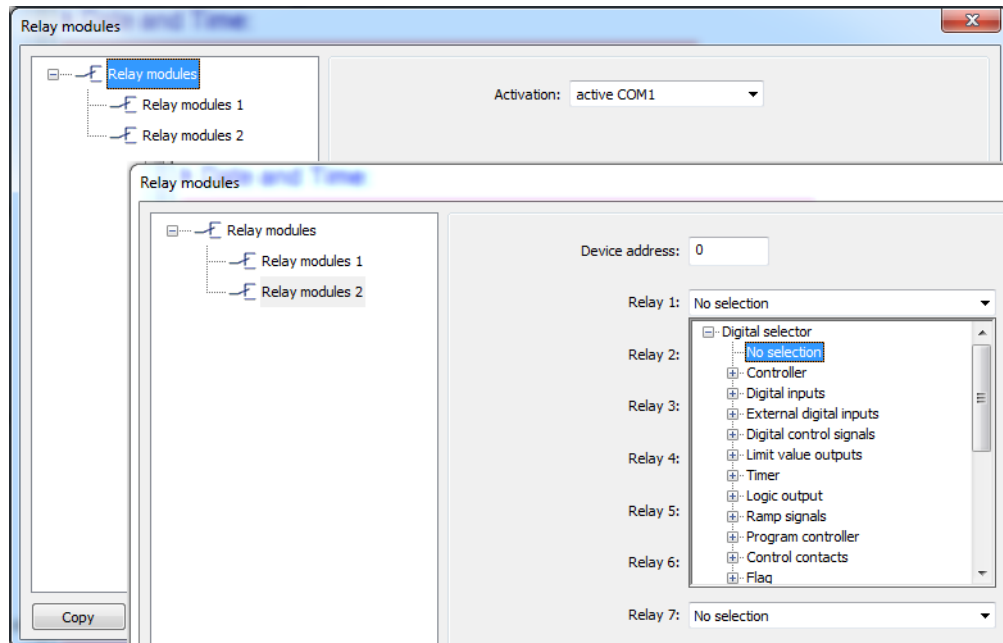

Parameters

Parameter	Selection/settings	Description
Activation	Inactive active COM1 active COM2	Not activated The external relay module is connected and activated at this interface. (only if the interface is integrated as an option)
Device address	0 to 255	
Relay 1 Relay 2 Relay 3 Relay 4 Relay 5 Relay 6 Relay 7 Relay 8	No selection Digital selector	- This signal is issued on the ER8 relay

12.23 PROFIBUS DP (option)

For a device with an integrated PROFIBUS DP optional board, the following settings can be made:

Setup dialog box

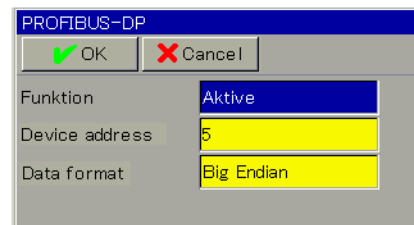
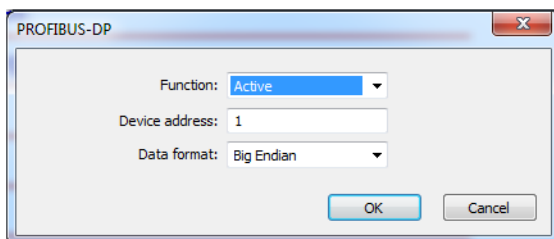

Parameters

Parameter	Selection/settings	Description
Function	Inactive Active	PROFIBUS inactive (bus error message suppressed) PROFIBUS active
Device address	0 to 127	-
Device address	1 to 125	May be used for the connected devices
Data format	Big Endian Little Endian	Also known as "Motorola format" Also known as "Intel format"

12 Configuration

13 Configuration – in setup program only

13.1 Installing the setup program

The setup program can be downloaded from "www.jumo.net" as a 30-day version. Once this period has elapsed you will need an activation code from JUMO in order to use the full range of functions. Follow the instructions on the screen.

13.1.1 Hardware

- 500 MB hard disk space
- 512 MB RAM

13.1.2 Software requirements

- Microsoft® Windows® XP
- Microsoft® Windows® 7, 32 or 64-bit

13.2 Starting the setup program

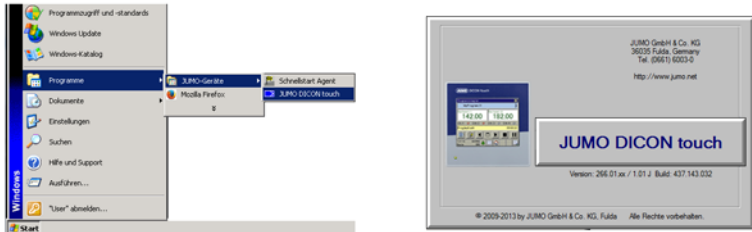
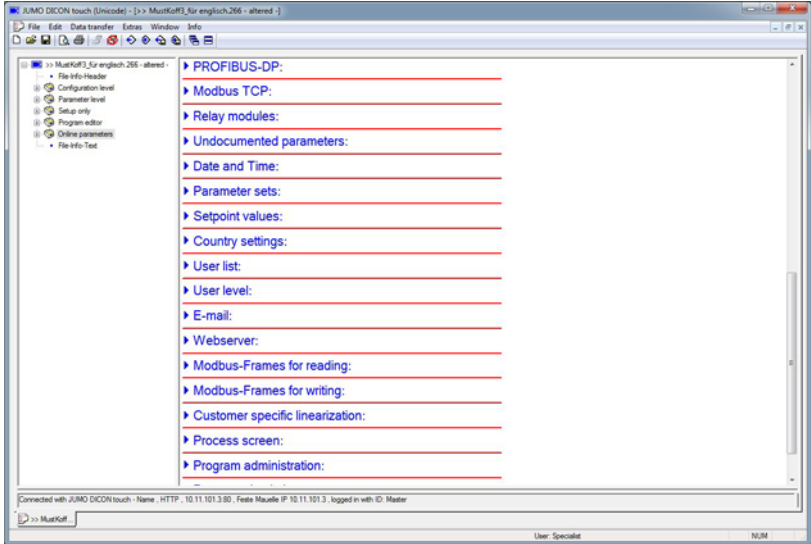
Step	Activity
1	<p>Start the program by selecting it from the start menu and the version display will appear briefly.</p> 
2	<p>The main window appears and the program can be run.</p> 

➔ Setup program started

13 Configuration – in setup program only

13.2.1 Establishing the connection to the device

First of all, you will see from the connection symbol on the menu panel that a device has not yet been connected.

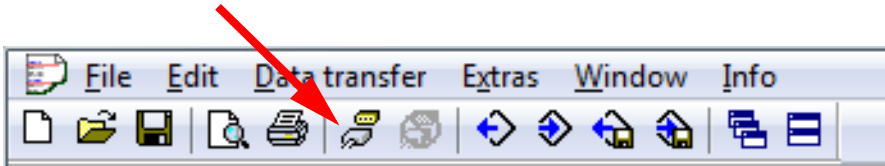

The following possibilities are available for connecting the device:

Via USB device interface

Step	Activity
1	Connect USB interfaces between the device and the PC
2	Click on CONNECT and the empty connection list will appear. Click on NEW ENTRY
3	Select Connection via USB and click NEXT
4	Select the USB connection and click Finish

➔ USB connection established

13 Configuration – in setup program only

Via Ethernet interface

Step	Activity
1	Connect Ethernet socket on the device with LAN socket on the router or company network and perform step 2 as with the USB interface
2	Select TCP/IP and click NEXT (no login)
3	Enter IP address of the device and click Finish

➔ LAN connection established

13.2.2 Setup data transfer to or from the external mass storage device

The setup program first saves the setup files on the internal hard disk drive, from which the setup program also runs.

However, setup files can also be exported/imported to/from a mass storage device from the device or with the setup program. The USB host socket is used for this purpose.

This means that devices with identical firmware versions can be easily duplicated.

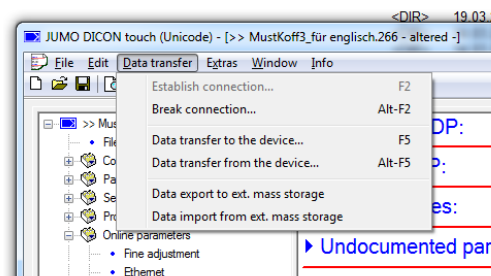
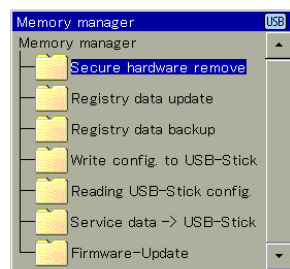

From the device	With the setup program
Write config. to USB-Stick	Setup data transfer from the device to an external mass storage device
Reading USB-Stick config.	Setup data transfer from the external mass storage device to the device

13 Configuration – in setup program only

13.3 Connection diagram

The rear side of the device is shown here with all the fitted hardware components that the setup program has detected.

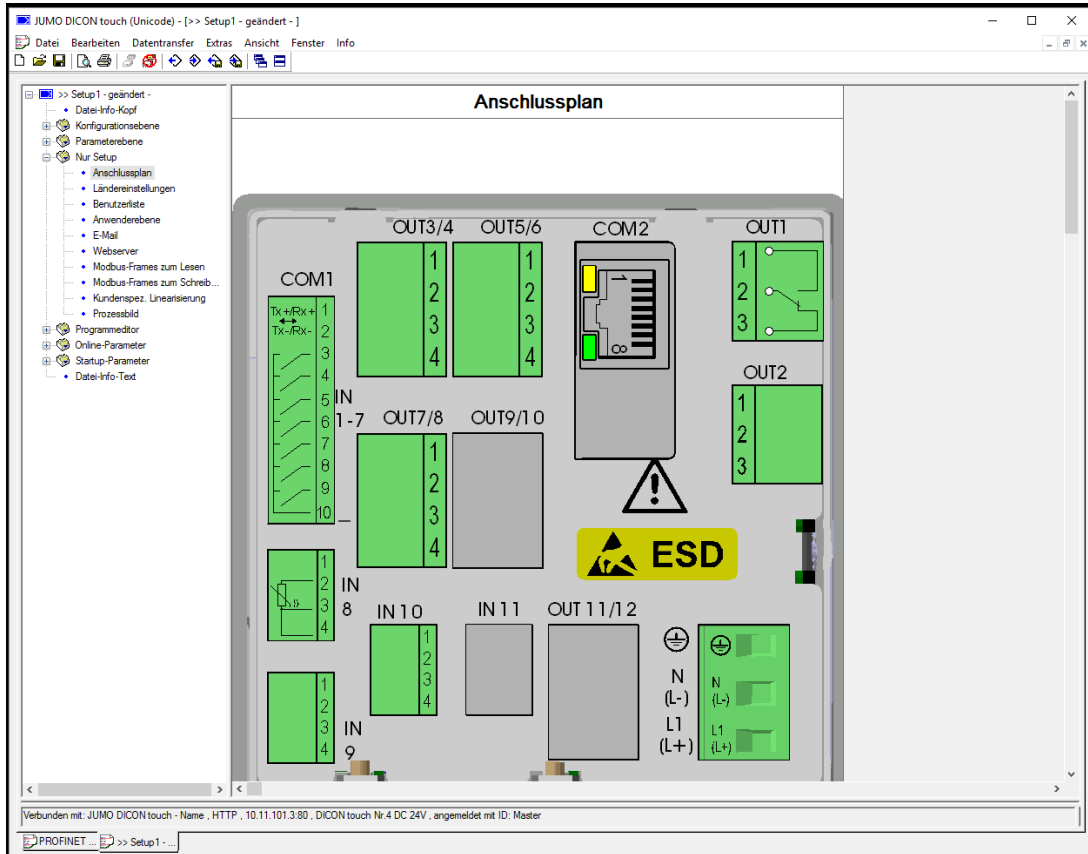

13 Configuration – in setup program only

13.4 Country settings

Additional device languages can be created or edited here. For example, French can be selected as a 2nd language from the current library and transferred to the device.

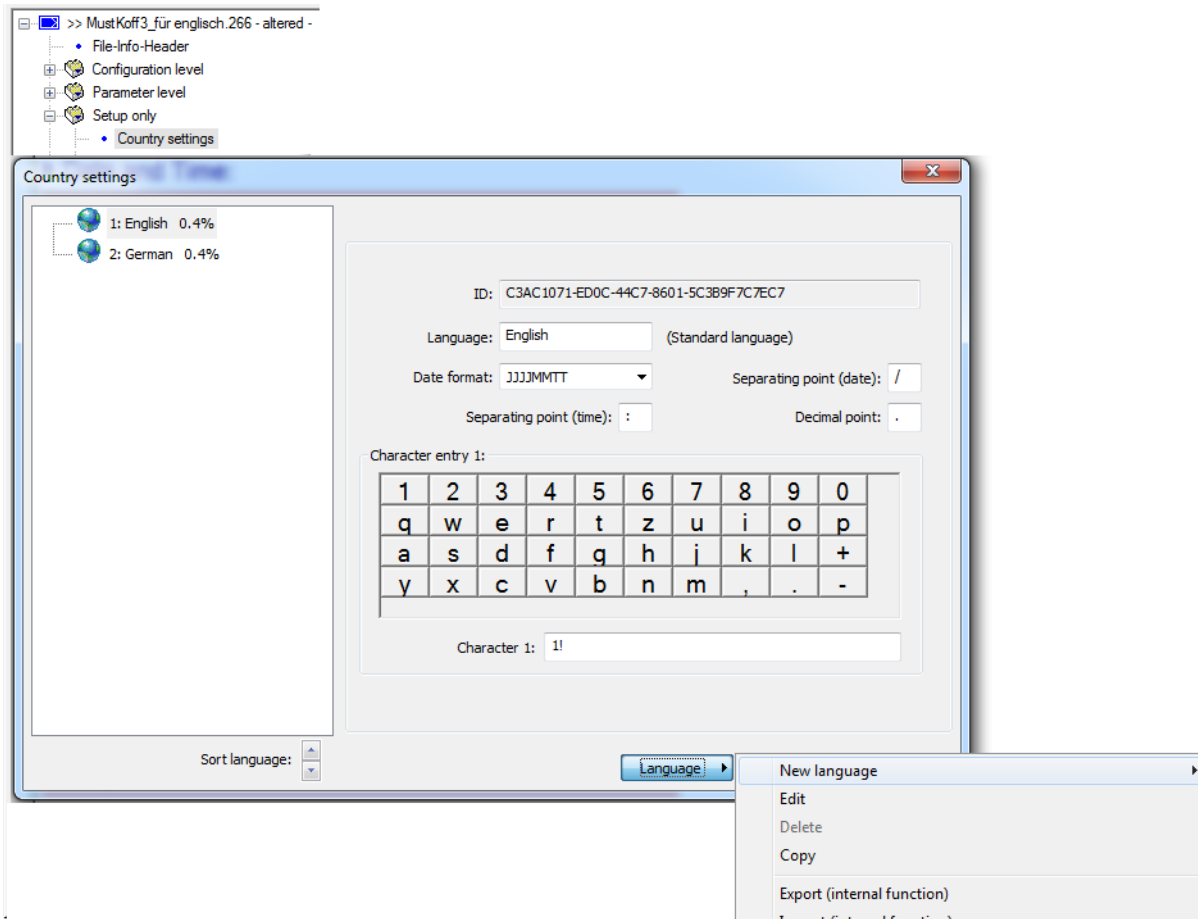

13.5 User list

The user currently logged in is displayed.

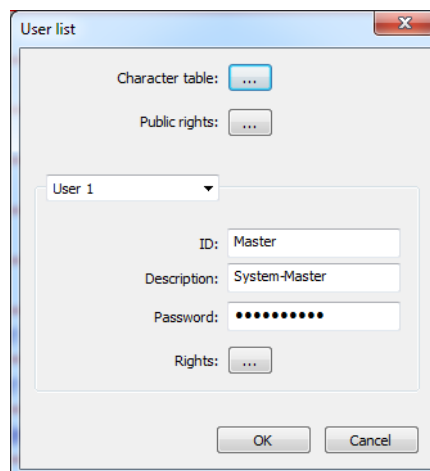

13 Configuration – in setup program only

13.6 User level

The user level can only be edited using the setup program. An example of this can be seen in Chapter 7.1 "Example 4 Transferring controller setpoint values to the user level", Page 47.

13.7 Email

5 different email texts can be entered here and sent, for instance in the event of an alarm in the plant.

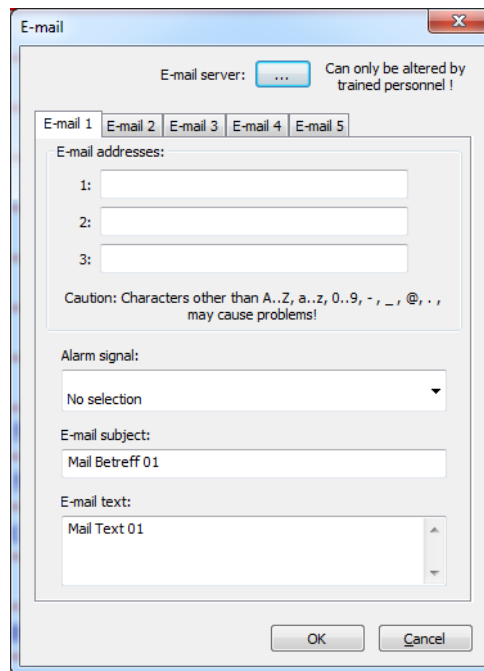

13.8 Web server

HTML documents, which can be created using a conventional HTML editor, can be stored in the JUMO DICON touch using the PC setup program. These documents can contain texts, graphics, and JavaScript code. Analog and digital values for the device can be displayed with JavaScript. The result is a website which can be retrieved over the Internet or LAN and displayed via a PC using a conventional web browser. On this website, the user can now see a clear display of the plant or the process, including measured values and operating statuses. A “standard online visualization” function is stored per default. A PC with Microsoft® Windows® operating system and Internet Explorer installed is required to use the online visualization. An HTML document can be created here which visualizes the DICON touch using a web application.

13 Configuration – in setup program only

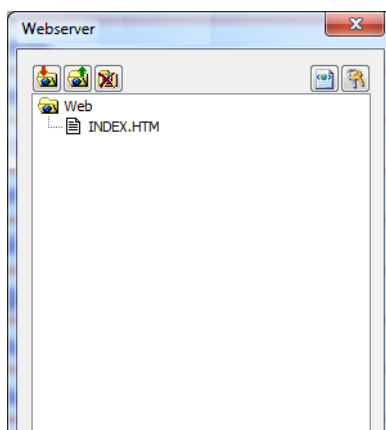

13.9 Modbus frames for reading

This function is used to compile up to eight Modbus frames for reading process values of external devices (via interface) individually for each opposite end. The process values (analog, integer, and digital values, and text) are written to the selected variables from the received Modbus telegram and are available for use in the system. Each frame can be used to configure up to 64 entries (variables); the process values are then grouped and transmitted in a Modbus telegram.

Setup dialog box

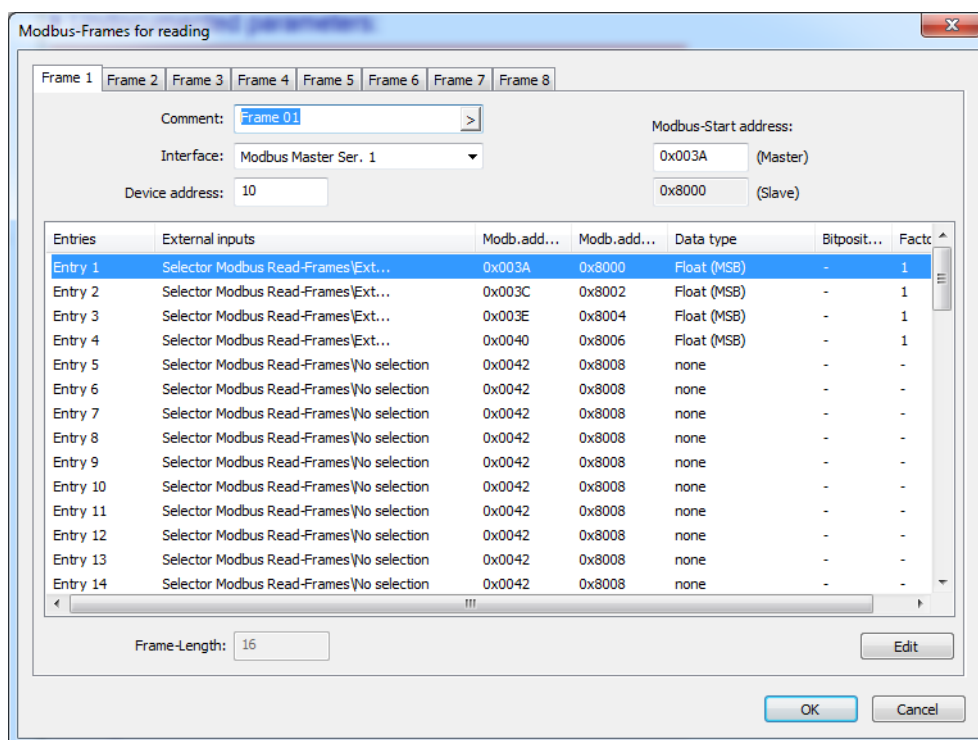

NOTE!

The configuration and use of the Modbus frames for writing are described in the Modbus interface description B 703571.2.0.

13 Configuration – in setup program only

13.10 Modbus frames for writing

This function is used to compile up to eight Modbus frames for writing process values to external devices (via interface) individually for each opposite end. The process values (analog, integer, and digital signals, and text) are written to the frames by the system and are available to external devices. Each frame can be used to configure up to 64 entries (process values), which are then grouped and transmitted in a Modbus telegram.

Setup dialog box

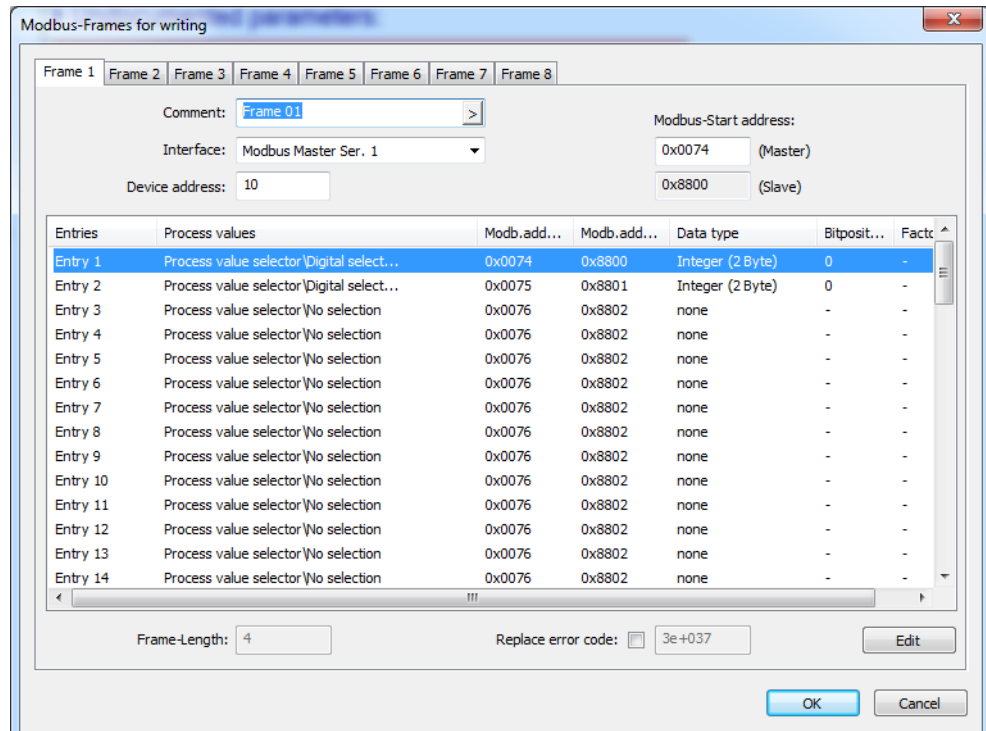

NOTE!

The configuration and use of the Modbus frames for writing are described in the Modbus interface description B 703571.2.0.

13 Configuration – in setup program only

13.11 PROFINET-RT

If the device is equipped with a PROFINET-RT interface class B, up to ten slots can be configured:

⇒ See PROFINET interface description

Setup dialog box

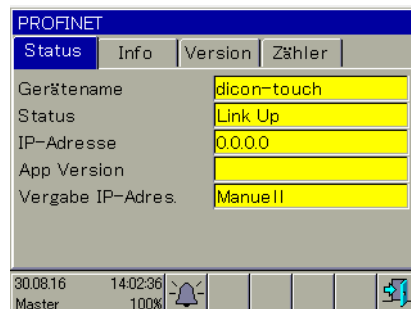
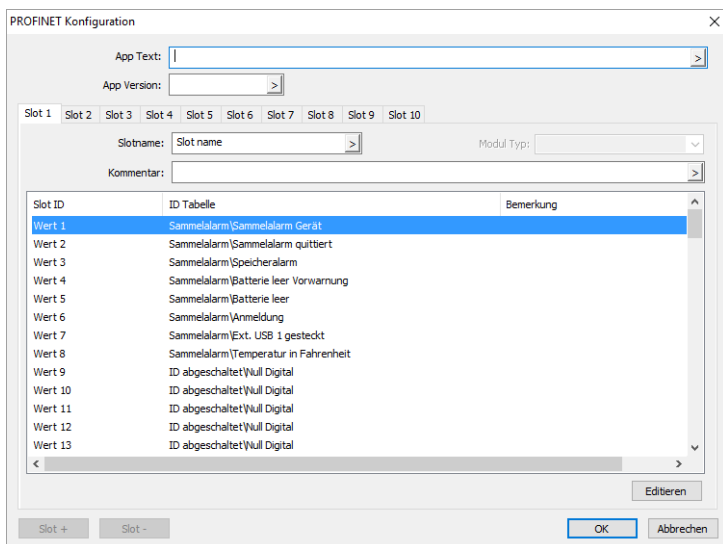

13 Configuration – in setup program only

13.12 Customer-specific linearization

No linearization tables are stored per default.
 A maximum of 4 linearizations can be created with the setup program.

13.12.1 Grid points

Customer-specific linearization is specified by entering up to 40 grid points (pairs of values X/Y). Here, value X indicates the physical measured value (in mV, mA, or Ohm for example; depending on the sensor type) and value Y indicates the linearized value (temperature in °C, for example).

Setup dialog box

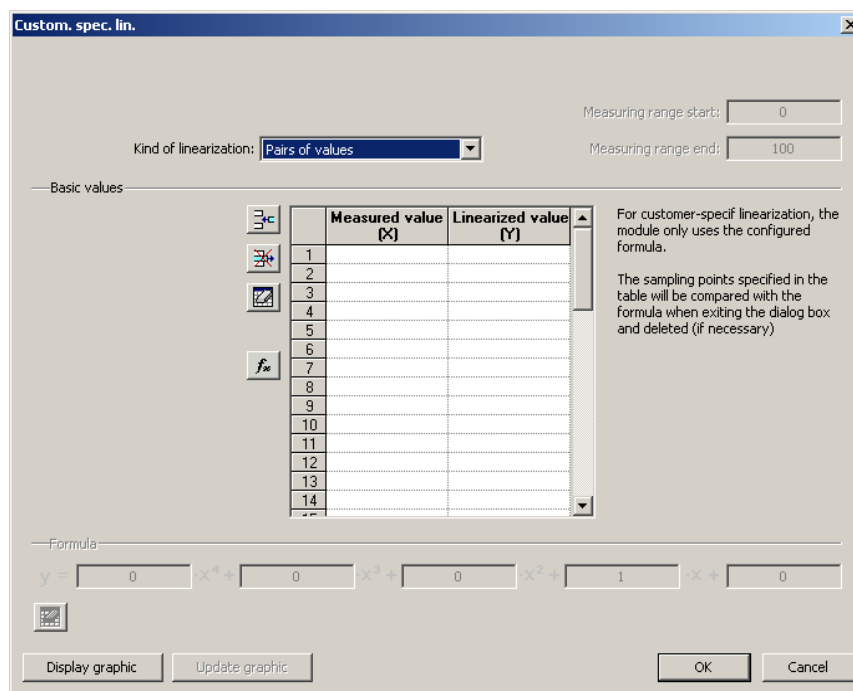

Parameters

Parameter	Selection/settings	Description
Measured value (X)	-99999 to 0 to +99999	Value of the relevant grid point on the x axis
Linearized value (Y)	-99999 to 0 to +99999	Value of the relevant grid point on the y axis

The definition range of linearization (measured values, x axis) is monitored in the module and delimited as follows:

Lower limit of the definition range = $X_{min} - 0.0125 \times (X_{max} - X_{min})$

Upper limit of the definition range = $X_{max} + 0.03125 \times (X_{max} - X_{min})$



NOTE!

A measured value outside of the definition range results in a deviation above or below the measuring range (out of range).

13 Configuration – in setup program only

Displaying linearization on a graphic ("Display graphic" button)

Use this button to create a graphic of the linearization.

The graphic includes the characteristic lines for both types of linearization where applicable, namely the grid points (table) and the formula.

The display range for the graphic is initially determined by the smallest and largest grid points; it can be temporarily changed in the display by entering different x values.

Calculating the polynomial using the grid points ("fx" button)

After entering the value pairs, use this button to calculate a polynomial that describes the progression of the linearization characteristic line.

The calculated coefficients are incorporated into the formula. The characteristic lines for both types of linearization then correspond to each other.

If the x values do not increase in a straight line, the linearization is not applied. In this case, it is impossible to display the graphic or calculate the polynomial.

13.12.2 Formula

Customer-specific linearization is specified using a 4th order polynomial. The polynomial is calculated for the entire linearization range.

Polynomial formula: $y = X4 \cdot x^4 + X3 \cdot x^3 + X2 \cdot x^2 + X1 \cdot x + X0$

Setup dialog box

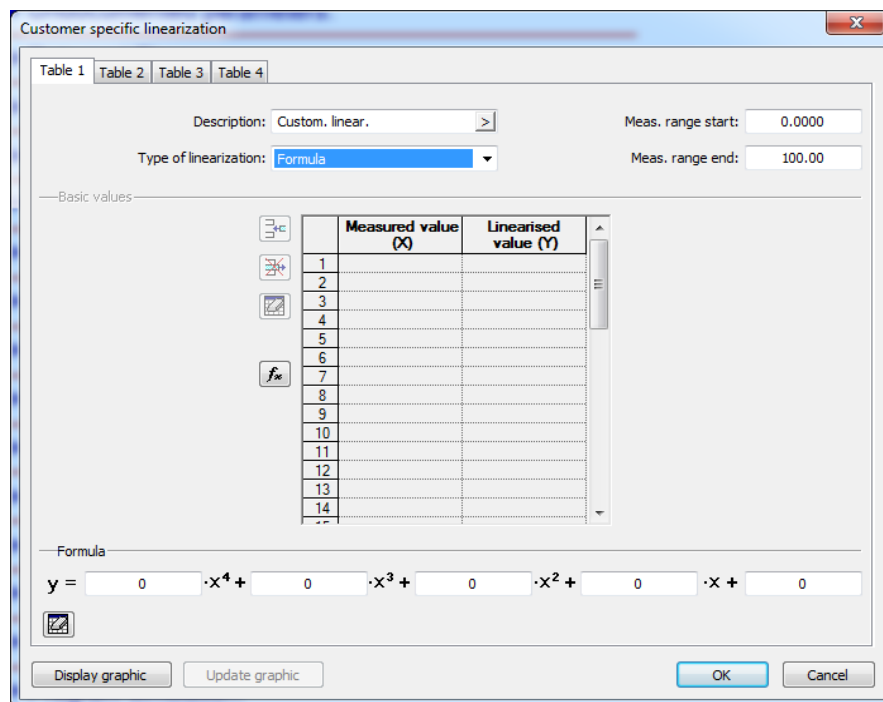

Parameters

Parameter	Selection/settings	Description
Meas. range start (Ymin)	-99999 to 0 to +99999	Start value of the y axis

13 Configuration – in setup program only

Parameter	Selection/settings	Description
Meas. range end (Ymax)	-99999 to 100 to +99999	End value of the y axis
X0	-99999 to 0 to +99999	Absolute component of the polynomial (point of intersection with the y axis)
X1	-99999 to 1 to +99999	Coefficient of the linear component (x)
X2	-99999 to 0 to +99999	Coefficient of the quadratic component (x ²)
X3	-99999 to 0 to +99999	Coefficient of the cubic component (x ³)
X4	-99999 to 0 to +99999	Coefficient of the quartic component (x ⁴)

The value range for the linearization (linearized values, y axis) is monitored in the module and limited as follows:

Lower limit of the value range = Ymin - 0.0125 × (Ymax - Ymin)

Upper limit of the value range = Ymax + 0.03125 × (Ymax - Ymin)



NOTE!

A linearized value that lies outside of the value range results in a deviation above or below the measuring range (out of range).

Displaying linearization on a graphic ("Display graphic" button)

Use this button to create a graphic of the linearization.

The graphic includes the characteristic lines for both types of linearization where applicable, namely the formula and the grid points (table).

The display range for the graphic is first of all determined by the "measuring range start" and "measuring range end" values (y values); it can be temporarily changed in the display by entering different x values

Example of 3rd-order polynomial

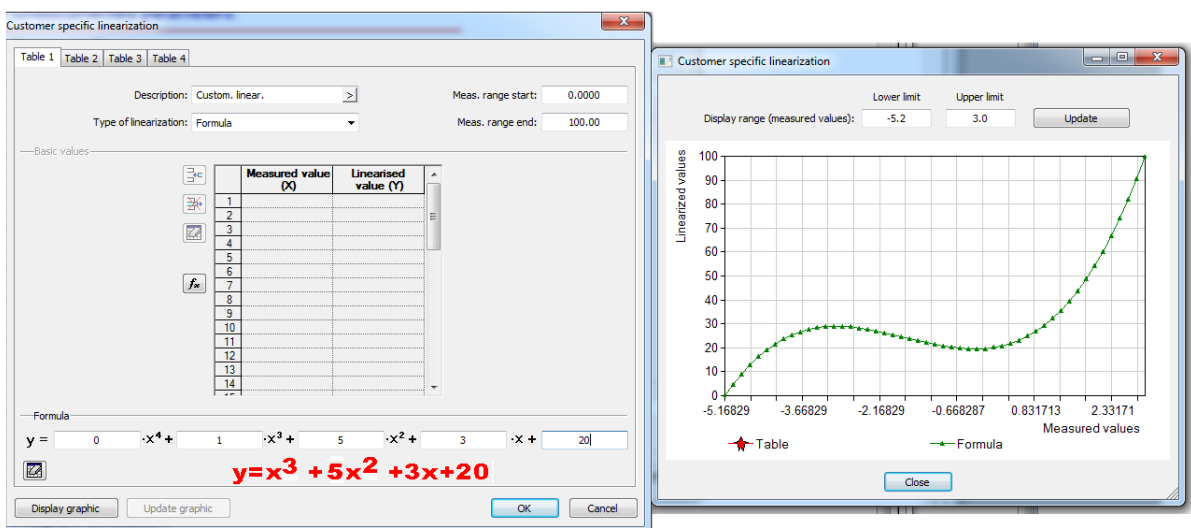

13 Configuration – in setup program only

13.13 Process screens 1 to 4

The process screen is empty per default and can only be created using the setup program.

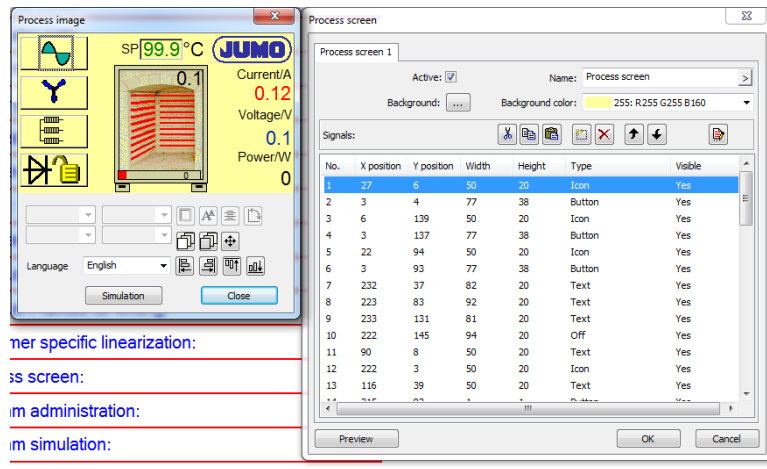

A process screen can consist of a maximum of 50 objects. These could be icons in bitmap format, frames, surfaces, texts, and analog and digital values of various colors and sizes. The object background is always located right at the bottom. All other objects at the bottom of the list are covered by those at the top.

If a particular object is problematic, it can first be set to **VISIBLE>NO**.

Preview

In the list on the right-hand side, the position for screen elements is set and displayed on the left in the preview. Clicking on an object (highlighted in blue) causes it to appear with a border on the left in the preview window. You can also click in the preview window.



NOTE!

Before beginning the screen layout, icons and background images must be contained in the library and in the "list of screens" (bitmap max. 320 x 182 pixels).

C:\Users\yourname\Documents\Set266u...

13 Configuration – in setup program only

13.13.1 Process screen editor

Setup dialog box

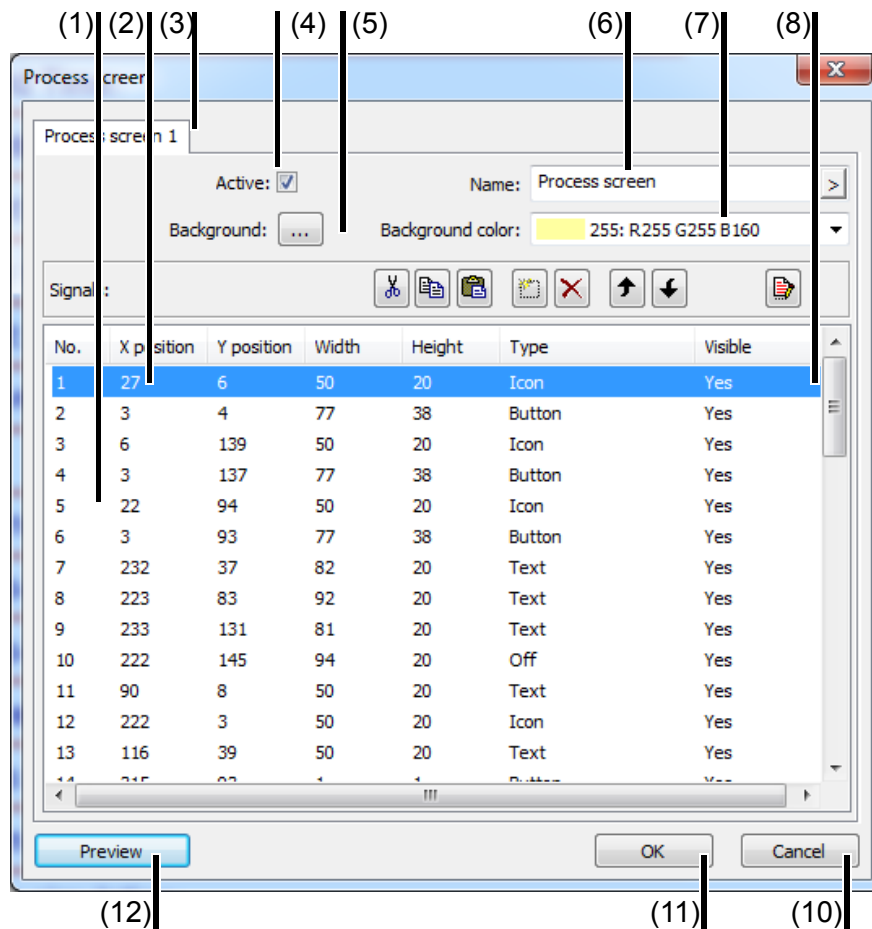





- (1) Object list
- (2) Object used
- (3) Selected process screen
- (4) Activate process screen
- (5) Select background image
- (6) Name of the process screen
- (7) Select background color
- (8) Navigation and editing functions
- (9) -
- (10) Exit process screen editor; settings are not adopted
- (11) Exit process screen editor; settings are adopted
- (12) Preview of the process screen (preview screen is opened in the setup program)

Navigation and editing functions

Button	Function
	Cut object from the object list
	Copy object to another object (only within the same process screen)
	Paste cut object into the object list
	Add new object to the object list

13 Configuration – in setup program only

Button	Function
	Remove object from the object list
	Move object up in object list
	Move object down in object list
	Edit object

13.13.2 Background

In addition to the background color, a background image can also be used for the background of the process screen. The background image is selected from the list of available screens in the setup program. If the background color is to be visible, the background image must not cover the entire area of the process screen or it must be transparent (option when replacing a screen).

Example

A furnace whose temperature is regulated via an thyristor power controller should be displayed here. For this purpose we need a screen of the plant with the most important parameters.

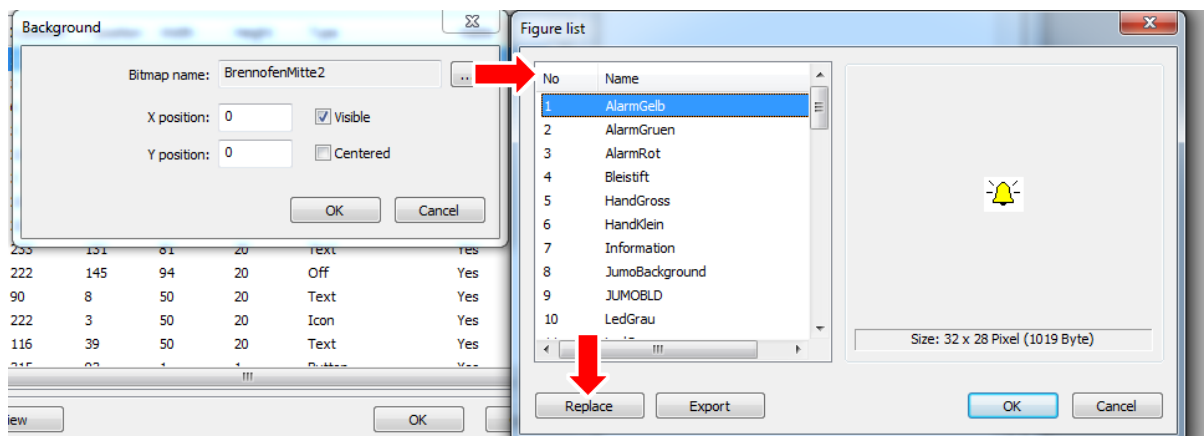

Assign screen name, click on "Visible", click ... , click "Replace"

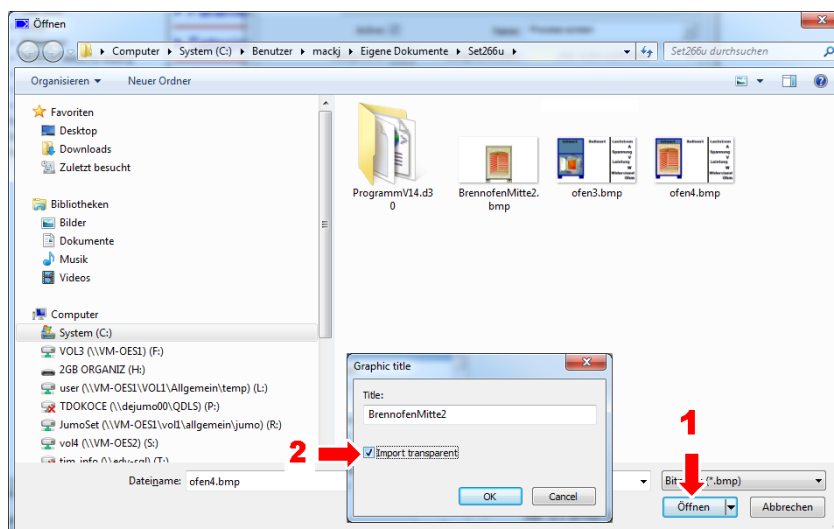

13 Configuration – in setup program only

Select the new furnace screen, click "Transparent" and it will appear in the list of screens.

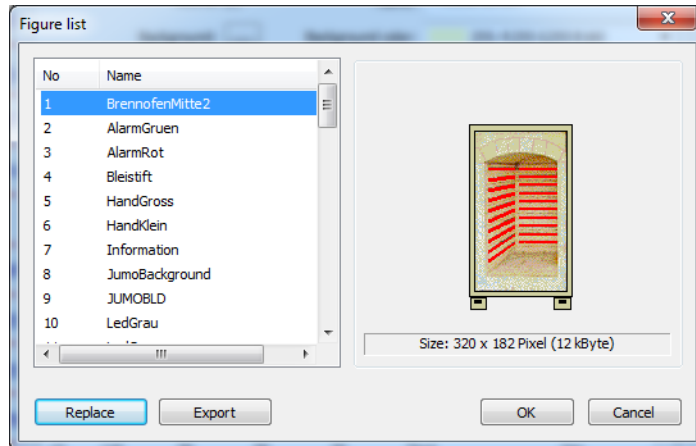

Once "Active" is ticked, the background image will appear in the preview.

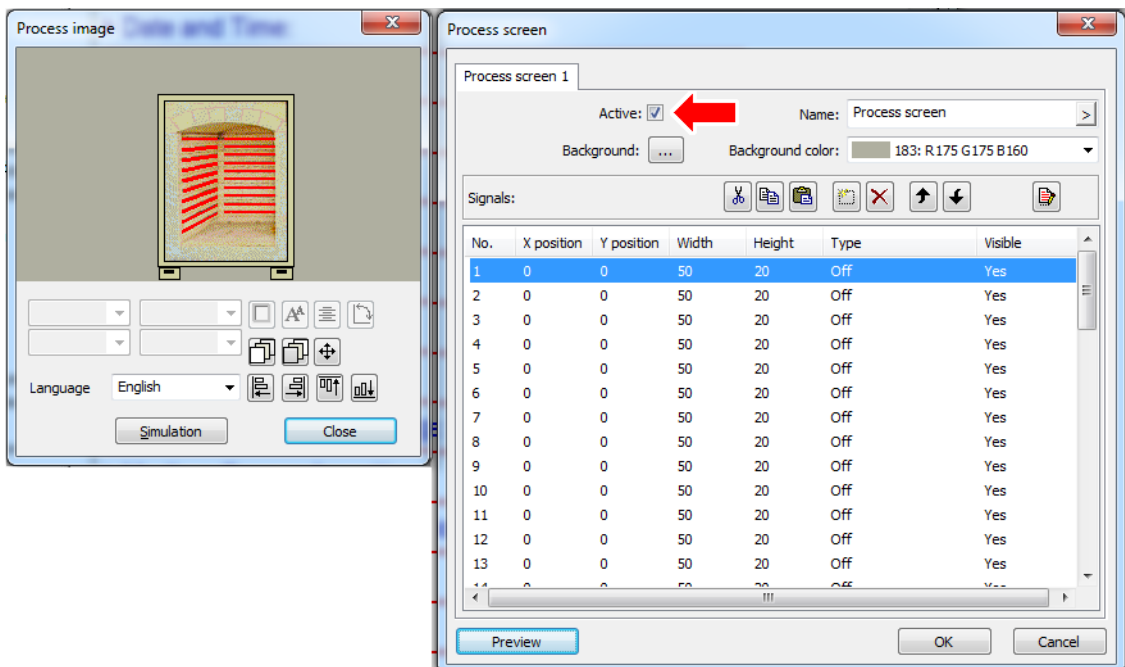

13 Configuration – in setup program only

13.13.3 Signal types for process screens (overview)

The variables and icons are now entered in the list until the process screen is complete. The first blue highlighted entry is highlighted with a border in the preview.

Setup dialog box

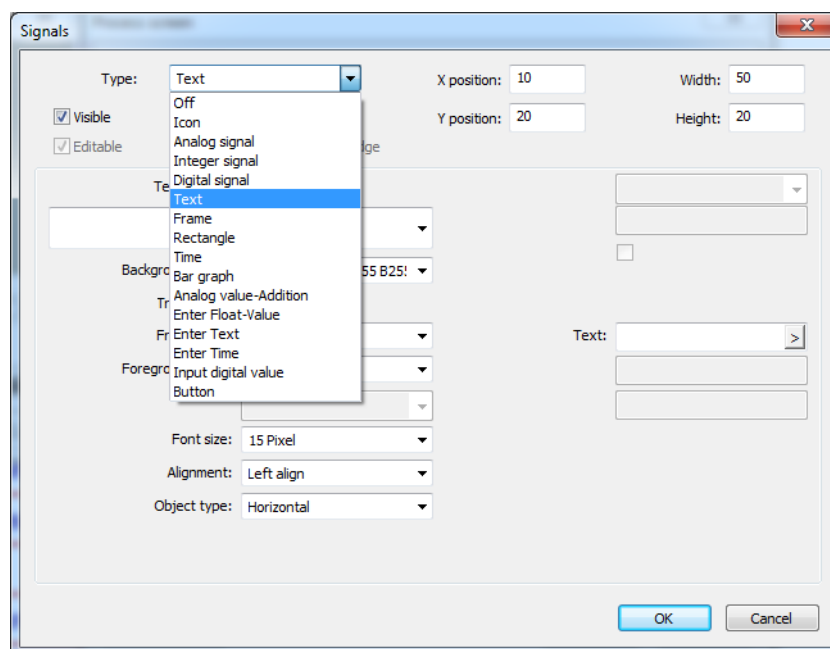

Signal types

Parameter	Description
Pictogram	Screwdriver, alarm bell...
Analog signal	...from the analog selector
Integer signal	...from the integer selector
Digital signal	...from the digital selector
Text	Text from the process or configuration selector
Frame	Transparent border
Rectangle	Rectangle with color fill and border
Time	Runtimes, timer times, service times
Bar graph	...from the analog selector
Analog value-Addition	Unit, channel description, min or max limit value
Enter Float-Value	Field for entering a floating point value
Enter Text	Field for entering a text
Enter Time	Field for entering the date or the time
Input digital value	Field for binary value output
Button	Button with touch function

13 Configuration – in setup program only

13.13.4 General object features

The description of the general object features applies for all object types for which the parameters in question are available.

The specific object features are described in the following chapters under the corresponding object type.

Setup dialog box

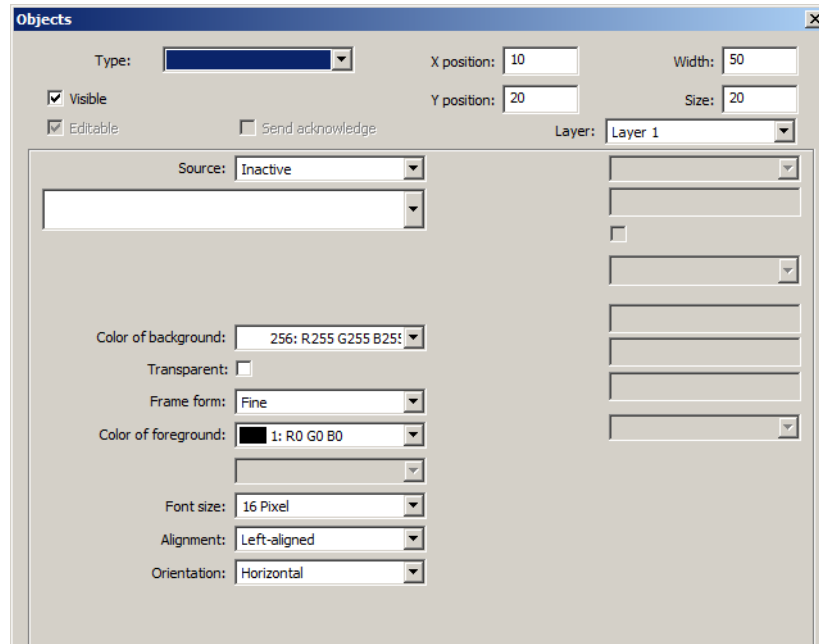

Parameters

Parameter	Selection/settings	Description
Type	Selection from list of object types	Object type for the process screen
X position	0 to 10 to 634	X coordinate of the upper left corner of the object in the process screen
Y position	0 to 20 to 402	Y coordinate of the upper left corner of the object in the process screen
Width	1 to 50 to 635	Width of the object
Size	1 to 20 to 403	Height of the object
Visible	Yes (), No () <input checked="" type="checkbox"/> <input type="checkbox"/>	"Yes" enables the display of the object in the process screen.
Editable	Yes (), No () <input checked="" type="checkbox"/> <input type="checkbox"/>	"Yes" enables the input option in the process screen (only for input objects).
Send acknowledge	Yes (), No () <input checked="" type="checkbox"/> <input type="checkbox"/>	"Yes" means that an acknowledgement is sent to the internal PLC following an entry in the process screen (only for input objects with a destination variable).
Color of background	Select color (drop-down menu).	Background color of the object

13 Configuration – in setup program only

Parameter	Selection/settings	Description
Transparent	Yes (<input type="checkbox"/>) , No (<input checked="" type="checkbox"/>) <input type="checkbox"/>	If "Yes", the background color of the object is not active. Instead, the font will be displayed in front of the background color of the process screen.
Frame form	Select form (drop-down menu).	The object can be provided with a border.
Color of foreground 	Select color (drop-down menu).	Font color within the object
Font size	Select font size (drop-down menu).	Font size within the object
Alignment	Select alignment (drop-down menu).	Alignment of the font within the object (left-aligned, right-aligned, centered)
Orientation (object type)	Select orientation (drop-down menu).	Orientation of the object in the process screen (horizontal, vertical; not for input objects).

Foreground color

In order for the font to be visible, the foreground and background color must be different from each another. If the "Transparent" setting is selected () , this applies with regard to the background color of the process screen.

13.13.5 Preview screen

A process screen that has been created can be inspected and changed in the preview screen using the setup program prior to being transferred to the device.





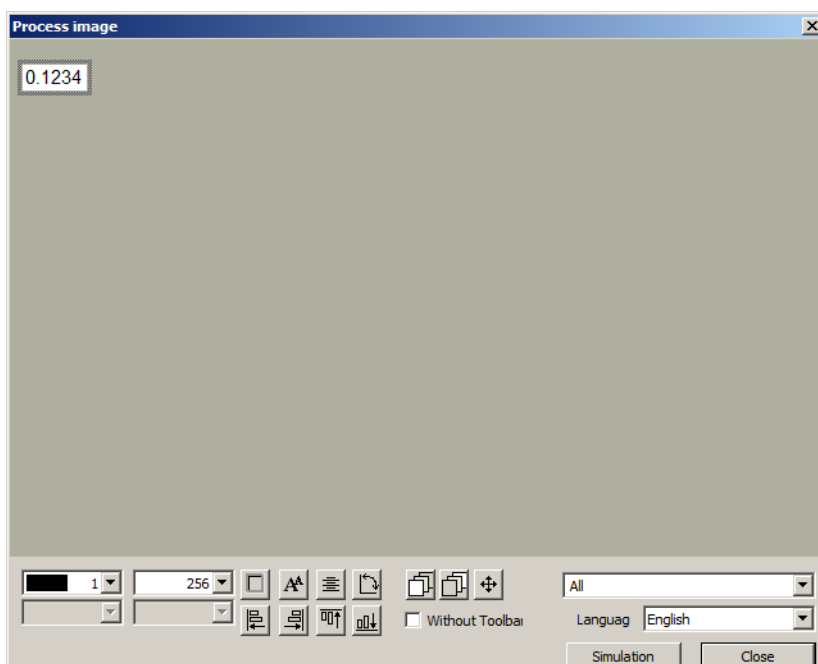

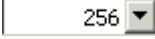

The preview screen is opened by pressing the "Preview" button:

Preview screen



13 Configuration – in setup program only

Editing functions

Button	Function
	Select foreground color (for example, font color) within the object (drop-down menu).
	Select background color of the object (drop-down menu).
	Change the frame form of the object (none, thin, thick, raised, recessed).
	Change the font size (12, 16, 24, 31, 48, 64 pixels).
	Change alignment of the font within the object (left-aligned, centered, right-aligned).
	Change orientation of the object in the process screen (horizontal, vertical).
	Move object in process screen forward one level with each click. The object is simultaneously moved down in the object list (higher number).
	Move object in process screen back one level with each click. The object is simultaneously moved up in the object list (smaller number).
	Move object in process screen horizontally or vertically. Clicking on this button opens an additional window. This contains different arrows (buttons) for moving the object in preset steps.

Editing the object features

Changes can be made directly to the object features in question using the editing functions described above. It is also possible to open the object by double-clicking (in the preview screen or in the object list) in order to edit the object features.

Moving objects

The user has the following options for moving an object in the preview screen:

- Double-clicking the object to open it and changing the X/Y position.
- Left-clicking and holding the object and moving it directly in the preview screen.
- Moving the object using the arrows.

Foreground color

In order for the font to be visible, the foreground and background color must be different from each another. If the "Transparent" setting is selected (), this applies with regard to the background color of the process screen.

13.13.6 Transferring the process screen to the device

As soon as the setup file has been transferred to the device, it can be retrieved in the operating loop.

14.1 Calibrating the touchscreen

The display on the TFT screen may no longer correspond to the points of contact on the adhesive touchscreen cover.

In this case, the touchscreen must be calibrated.

DEVICE MENU>CALIBRATE TOUCHSCREEN

To do this, 4 points on the screen with an 'x' must alternately be tapped as accurately as possible with a pen.

The device saves these coordinates and this matches up the TFT screen and the touchscreen again.

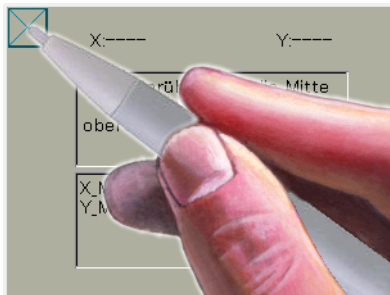

14 Special functions

15.1 Fine adjustment

You can use customer-specific fine adjustment to correct the measured values of the analog input. In contrast to offsetting, which is used to specify a constant correction value for the entire characteristic line, fine adjustment can also be used to change the slope of the characteristic line.

Setup dialog box

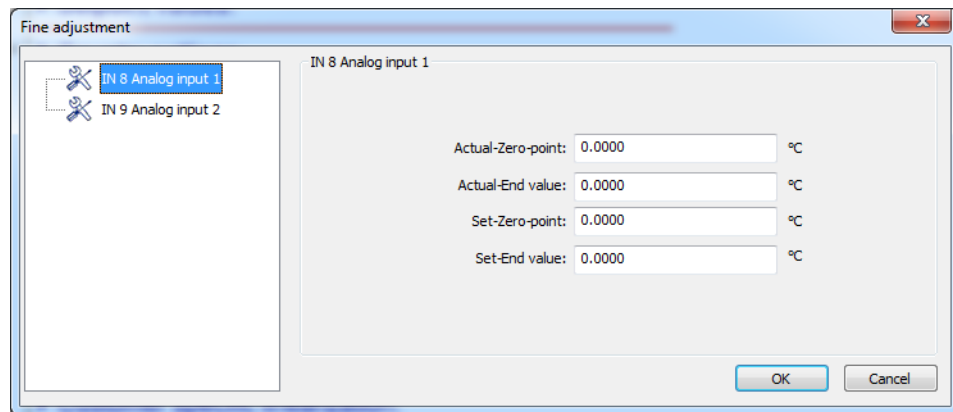

Parameters

Parameter	Selection/settings	Description
Actual-Zero-point	-99999 to 0 to +99999	Lower displayed value
Actual-End value	-99999 to 0 to +99999	Upper displayed value
Set-Zero-point	-99999 to 0 to +99999	Lower reference value
Set-End value	-99999 to 0 to +99999	Upper reference value

Example

The temperature inside a furnace is measured with an RTD temperature probe and displayed. Due to the temperature drift of the sensor, the true temperature (reference measurement) deviates from the displayed value. The amount of deviation is different at the upper and lower measuring points, meaning that measured value offset is not suitable.

Actual zero point: 15 °C (lower displayed value)

Set zero point: 20 °C (lower reference value)

Actual end value: 70 °C (upper displayed value)

Set end value: 80 °C (upper reference value)

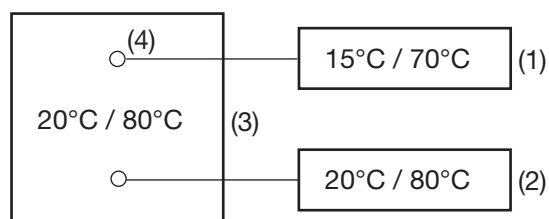

(1) Display values

(3) Furnace

(2) Reference values

(4) Sensor in RTD temperature probe

15 Online parameters

Performing fine adjustment

- 1) Determine the lower value (as low and constant as possible) with the reference measuring device.
Example: Set furnace temperature to 20 °C.
- 2) Enter the display value as the actual zero point and the reference value as the set zero point.
Example: Enter 15 and 20.
- 3) Determine the upper value (as high and constant as possible) with the reference measuring device.
Example: Increase furnace temperature to 80 °C.
- 4) Enter the display value as the actual end value and the reference value as the set end value.
Example: Enter 70 and 80.

Characteristic line

The following diagram shows the changes in the characteristic line caused by the fine adjustment (point of intersection with the x axis as well as the slope).

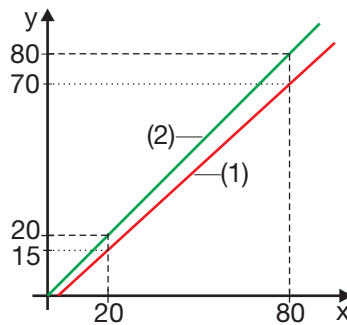

y Display value
x Reference value

(1) Characteristic line before fine adjustment
(2) Characteristic line after fine adjustment

Resetting the fine adjustment

The following settings must be made to reverse the fine adjustment:
Actual zero point = set zero point
Actual end value = set end value

15.2 Ethernet (option)

There is no Ethernet interface available per default. If it has been integrated into the device using optional boards, the following values can be set:

Setup dialog box

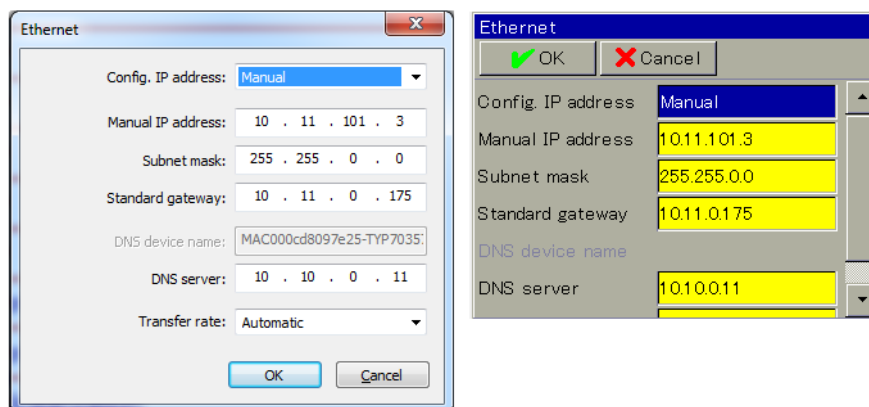

Parameters

Parameter	Selection/settings	Description
Config. IP address	Automatic Manual	The DICON touch automatically obtains its IP address from the DHCP server. The IP address for the DICON touch must be assigned manually.
Manual IP address	0.0.0.0 to 233.233.233.1 to 255.255.255.255	The IP address is entered manually here (if necessary, it should be requested from the administrator responsible).
Subnet mask	0.0.0.0 to 255.255.255.0 to 255.255.255.255	Manual setting of the subnet mask
Standardgateway	0.0.0.0 to 255.255.255.255	Manual setting of the IP address of the standard gateway (router)
DNS device name	097e25-TYP703571 Admissible characters:a to z, A to z, -, 0 to 9 (max. 63 characters); name must start with a letter and must not end with "-" (hyphen)	Example of unique DNS device name for DICON touch (assigned per default)
DNS server	0.0.0.0 to 255.255.255.255	IP address of the DNS server
Transfer rate	Automatic 10 MBit/s half duplex 10 MBit/s full duplex 100 MBit/s half duplex 100 MBit/s full duplex	Data transfer rate of Ethernet connection

15 Online parameters

15.3 Date and time

The date and time for the device can be adopted from the connected PC or entered manually.

Setup dialog box

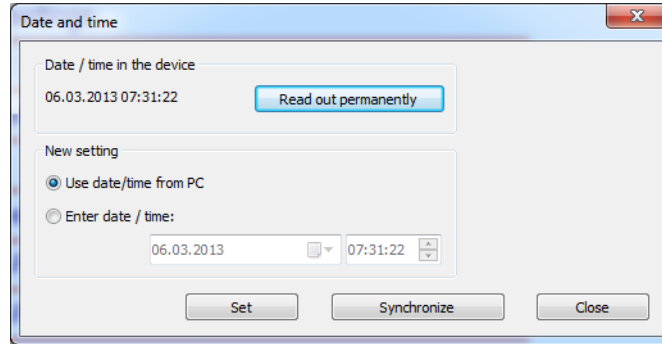

15.4 Screenshot

A screenshot of the current device can be created here and saved as a bitmap.

Setup dialog box

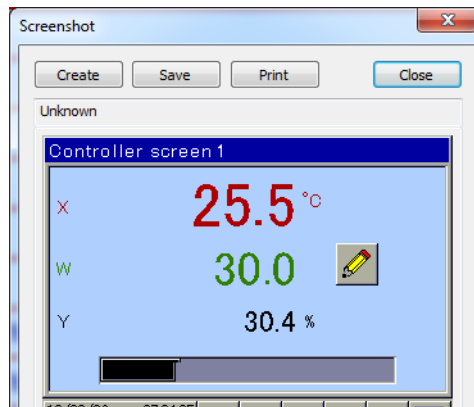

15.5 Deleting the measurement-data memory

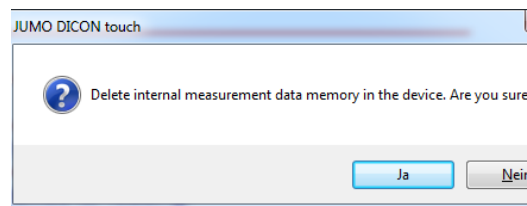

A screenshot of the current device can be created here and saved as a bitmap.

Setup dialog box

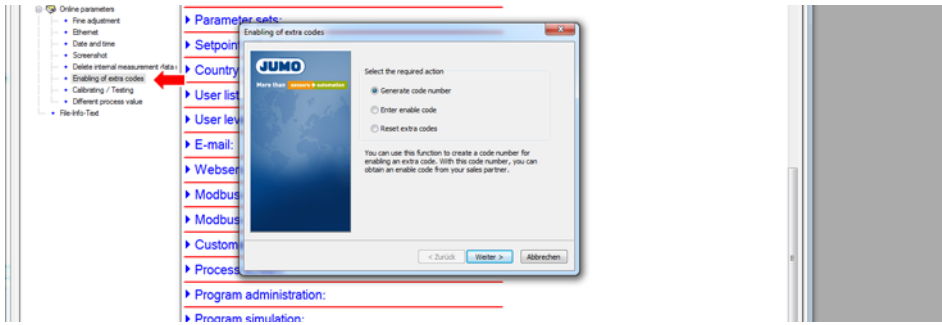
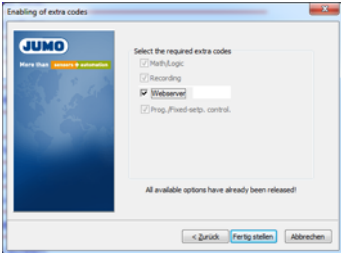

15.6 Approval of extra codes

To do this, you need a device that is connected to the setup program.

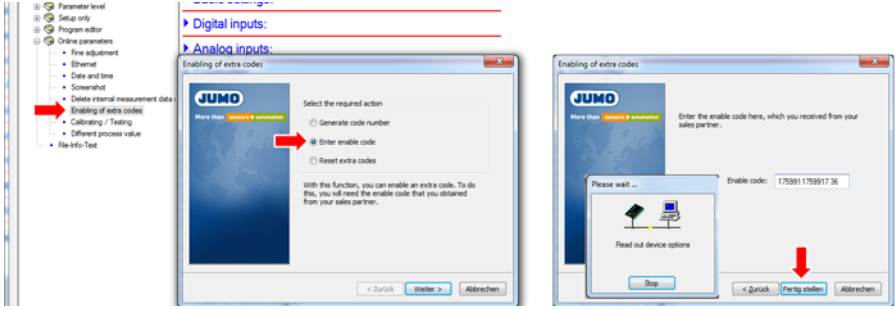
Step	Activity
1	Connect device to the PC using the USB or LAN
2	Click on ENABLING OF EXTRA CODES 
3	Generate code number and click Next
4	Select the required extra codes and click Next 
5	Code number appears 
6	Send the code number to JUMO and the activation code will be sent to you.
7	Enter the activation code under ENABLING OF EXTRA CODES and click Next. 

➔ Extra code enabled

15 Online parameters

15.7 Testing calibration

This area shows the dialogs for calibration and testing of analog and digital outputs as well as other device functions.

Setup dialog box

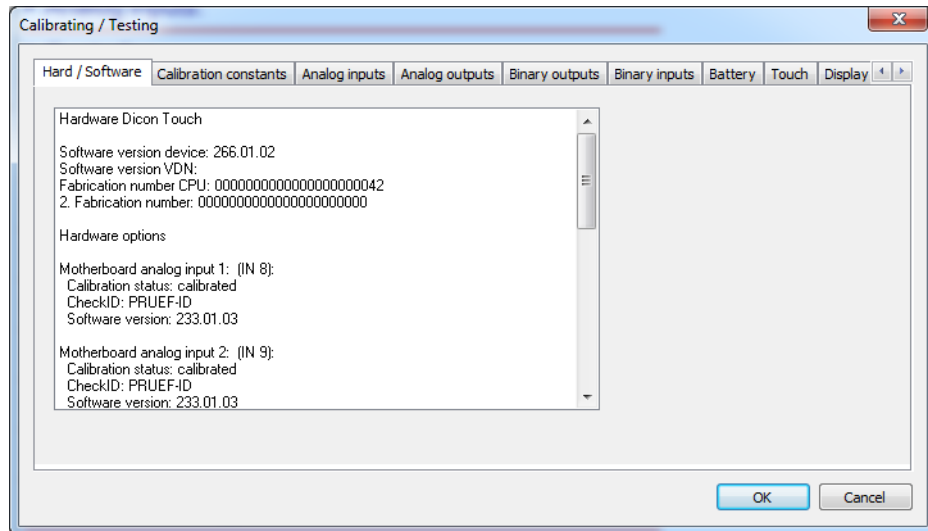

15.8 Different process values

Values can be read and saved here.

Setup dialog box

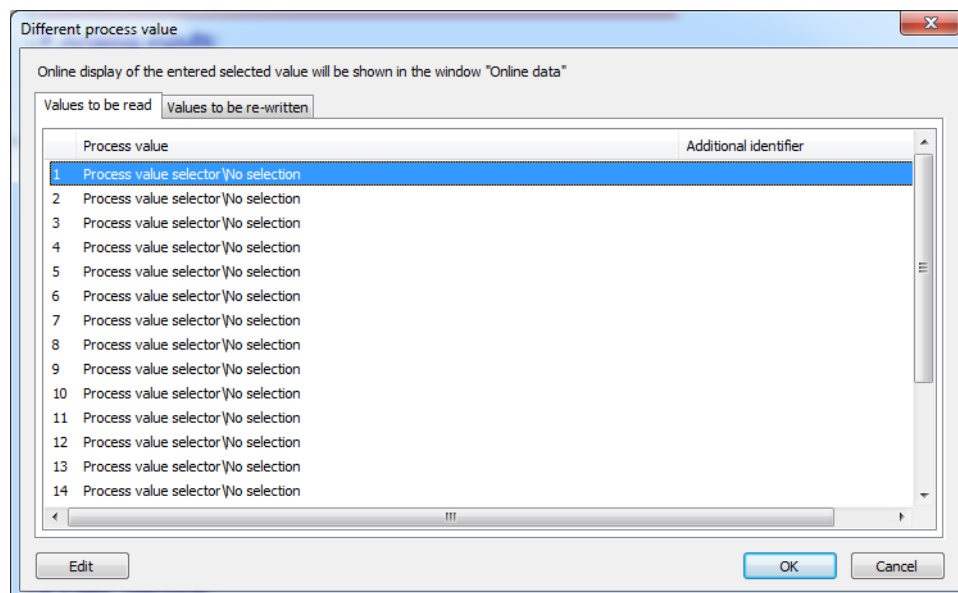

15.9 Startup program

The setup program has a convenient software tool that monitors, documents, and thus substantially simplifies the startup process.

This startup software makes it possible to visualize and save analog and binary signals while the plant is being optimized.

Such a visual representation of the important process data in real time is almost indispensable to control engineers, particularly with difficult processes.

Only the controller, a PC or laptop with the setup program and an interface connection (USB or Ethernet) are required for the plant optimization. Important settings such as free signal selection for displaying individual analog and digital signals on the device, zooming, different printing options, showing or hiding individual curves, free scaling and color selection are included in this software tool per default.

The program's essential tasks include:

- Monitoring and documenting the optimization or autotuning phase
- Triggering of a setpoint value step change for recording and determining control-related characteristic values based on the plant behavior
-
- Comparison of multiple control results with various control parameters
- Random monitoring of control quality during the production phase or during the tool change
- Saving these data files to quickly send them via email to an expert board

The program not only provides practical benefits, it also includes many further advantages – particularly in terms of cost benefits – compared to conventional process monitoring, e.g.:

- No additional recorders and other peripheral devices required for startup
- Little time required for setup and wiring work for measuring equipment
- No installation of other sensor technology on the plant or analog signals from the control device required
- Large time saving thanks to simple Plug and Play interface cable
- All important process data at a glance

15 Online parameters

16.1 Error messages in float values and on the display

The float value itself is used for the display. The following statuses are defined.

Error	Float value display	Display
First error value	1.0E+37	
Software – underrange	1.0E+37	<<<<<<
Software – overrange	2.0E+37	>>>>>>
No valid input value	3.0E+37	-----
Division by zero	4.0E+37	-----
Incorrect mathematical value	5.0E+37	-----
Display capacity exceeded		*****
Invalid value		-----

In the event of an error, the device function reports this error in its output value itself. All device functions monitor an input value for these error values. In the event of an error, the output value is in turn set to one of these error values, or another value is specified in the configuration (error value/replacement value).

16.2 Display of error messages for binary values

Binary input values are displayed with 0 and 1 only. If there is no valid input value, or if the device function is unable to supply a valid output value, the value is set to 0.

Exception

If, in the configuration level, you set which value the output should adopt in the event of an error (error value/replacement value), this value is shown.

Display start/end:

This is used to define the scope of the display for the graphic display elements (upper and lower limit for a bar graph display). The numeric representation is independent of the display start/end and is produced over the entire measuring range. In the recording, measured values smaller than the display start are saved as UNDERRANGE and measured values larger than the display end are saved as OVERRANGE.

Bar graph display:

The numeric representation is independent of the display start/end and is produced over the entire measuring range. In the recording, measured values smaller than the display start are saved as UNDERRANGE and measured values larger than the display end are saved as OVERRANGE.

Over- and underrange:

This is detected at the hardware limits/on the scaling in mV. The maximum possible scope of display is therefore always available. For all the values calculated in the device such as math output, flow, and external inputs, the following applies: The scope of display has the same significance here as for the hardware inputs.

16 Error and alarm messages

17 Retrofitting optional boards

17.1 Safety information

You can upgrade or retrofit the device flexibly using the following description. All necessary settings are described in this operating manual. Manipulations not described in the operating manual or which are expressly forbidden will jeopardize your warranty rights.



CAUTION!

The modules may be damaged by electrostatic discharge. For this reason, avoid electrostatic charges during fitting and removal. Work in a "grounded" working area with the relevant equipment!



DANGER!

Risk of high voltage from touching live parts inside the device. Disconnect (all poles) the device from the voltage supply before retrofitting. Only qualified personnel are permitted to carry out module retrofits. The country-specific requirements regarding changes to an electrical device must be observed.

17.2 Identifying the modules

1	Identify the module from the part number on the sticker attached to the packaging
2	Check which slot the optional board may be inserted into. ⇒ Chapter 4.3 "Connection diagram", Page26
3	Only install modules that are permitted for this expansion slot into your device.

Block diagram

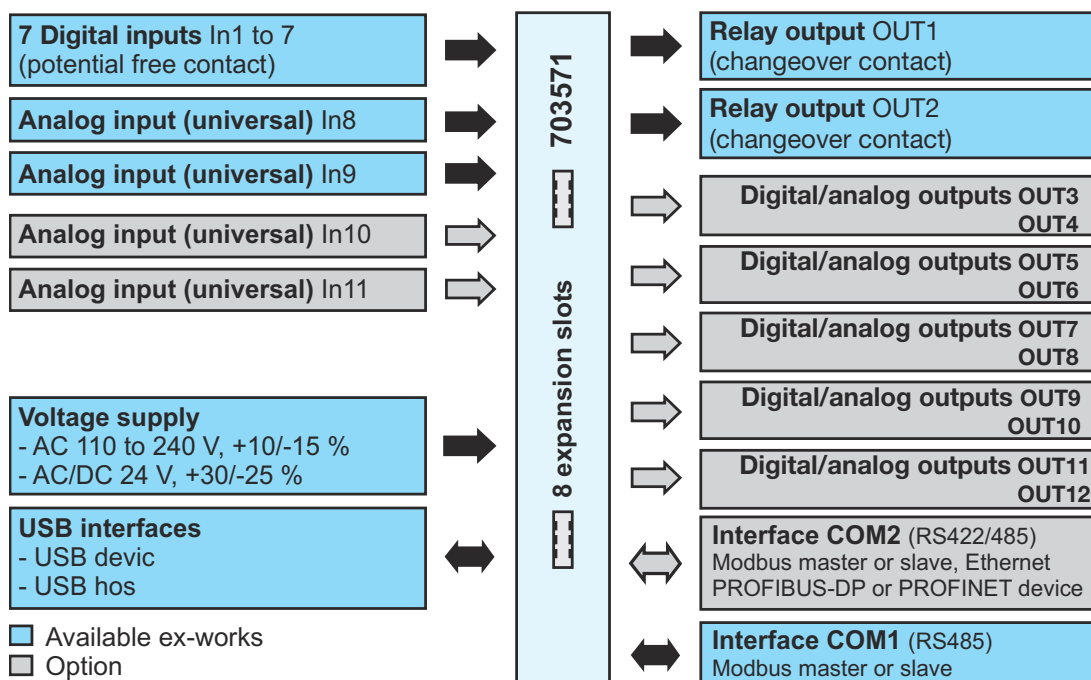

17 Retrofitting optional boards

17.3 Installing modules

In this example, a universal analog input is inserted in slot In10.

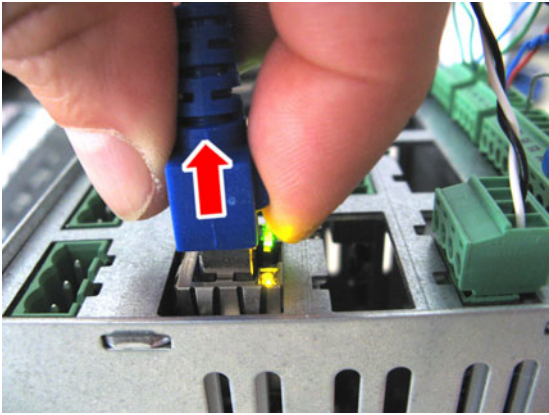
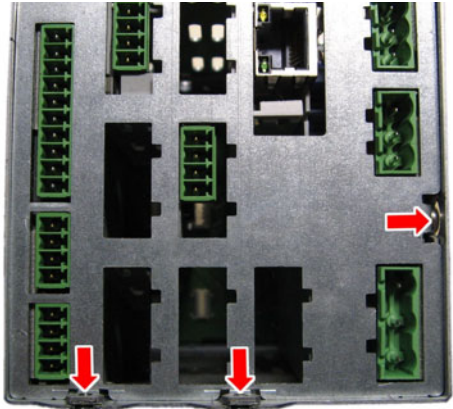
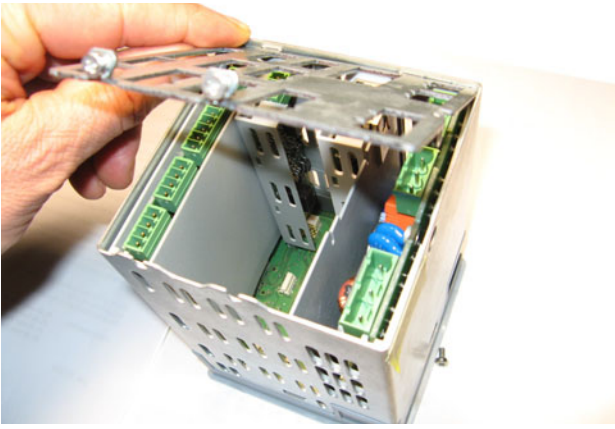
Step	Activity
1	Disconnect screw terminals connected at the rear and connected interface cables 
2	Loosen 2 screws at bottom (do not remove), remove side screw completely 
3	Lift up back panel and pull out 



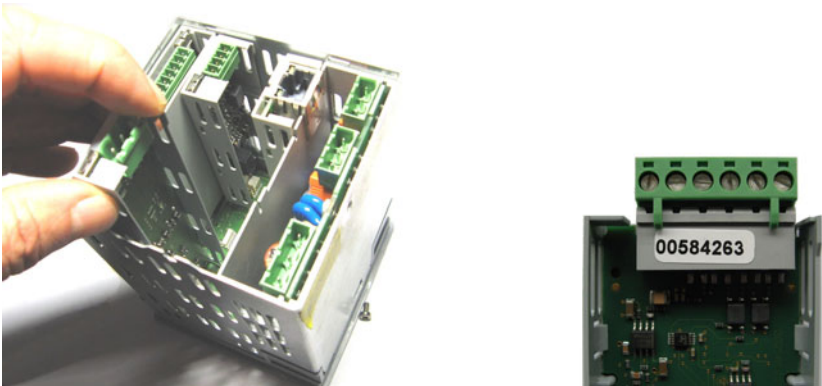
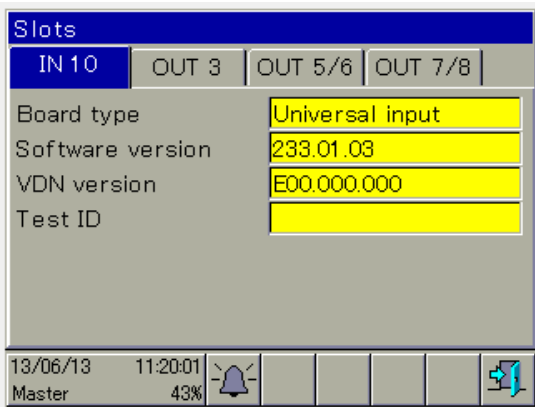
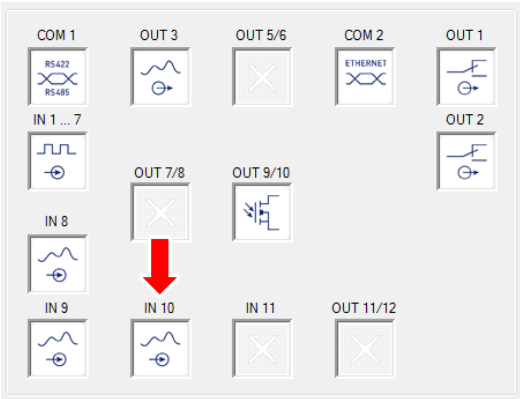



17 Retrofitting optional boards

Step	Activity
4	<p>Slide optional board into the slot provided. The part no. is located on the screw terminal.</p> 
5	<p>Re-tighten the 2 screws with the associated toothed lock washers and screw in the side screw again, to ensure a conductive connection between the back panel and the side panel (secure grounding).</p>
6	<p>Switch on the device again and check whether the new hardware is recognized. The new slot should appear in the device as follows: DEVICE INFO -> SLOTS</p>  <p>IT IS RECOGNIZED IN THE SETUP PROGRAM BY THE HARDWARE ASSISTANT: CURRENT HARDWARE -> HARDWARE ASSISTANT</p> 

➔ Result: The correctly recognized slot can now be configured and connected.

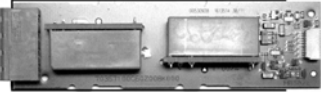
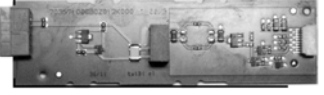
17 Retrofitting optional boards

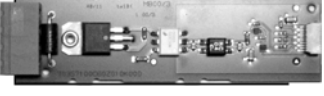
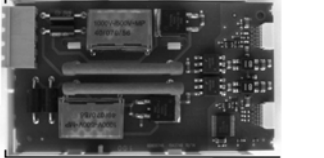
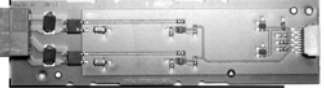
17.3.1 Accessories

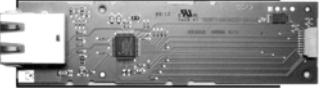
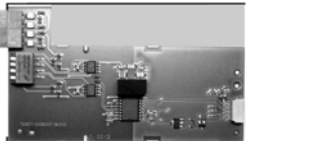
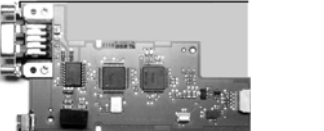
Item	Parts no.	
Modules for expansion slots:		
One analog input (universal)		00581159
One relay output (changeover contact)		00581160
Two relay outputs (N/O contact)		00581162
One logic output DC 0/22 V, max. 30 mA		00581165
Two logic outputs DC 0/12 V max. 20 mA		00581168
One solid state relay AC 230 V, 1 A		00581164
Two solid state relays AC 230 V, 1 A for motor actuator		00621574
Two PhotoMOS® relays ¹ DC 45 V, max. 200 mA, AC 30 V, max. 200 mA		00581171
One analog output (universal)		00581169
Ethernet interface		00581174
Serial interface RS422/RS485		00581172
PROFIBUS-DP interface		00581173

¹ PhotoMOS is a registered trademark of Panasonic Corporation

18.1 GL



TYPE APPROVAL CERTIFICATE

Certificate No:
TAA000014K
Revision No:
1

This is to certify:

That the Peripheral Equipment

with type designation(s)

JUMO AQUIS touch P (202580), JUMO DICON touch (703571)

Issued to

JUMO GmbH & Co. KG
Fulda, Hessen, Germany

is found to comply with

DNV GL rules for classification – Ships, offshore units, and high speed and light craft

Application :

Product(s) approved by this certificate is/are accepted for installation on all vessels classed by DNV GL.

Location class:

Type	Temperature	Humidity	Vibration	EMC	Enclosure
JUMO AQUIS touch P (202580)	B	B	A	B	A, B(front, IP66)
JUMO DICON touch (703571)	B	B	A	B	A, B(front, IP66)

Issued at **Hamburg** on **2018-12-05**

This Certificate is valid until **2022-04-20**.

DNV GL local station: **Magdeburg**

Approval Engineer: **Jens Dietrich**



Digitally Signed By: Rinkel, Marco

for **DNV GL**

Location: Hamburg, on behalf of

Joannis Papanuskas
Head of Section

This Certificate is subject to terms and conditions overleaf. Any significant change in design or construction may render this Certificate invalid. The validity date relates to the Type Approval Certificate and not to the approval of equipment/systems installed.



Form code: TA 251

Revision: 2016-12

www.dnvgl.com

Page 1 of 6

© DNV GL 2014. DNV GL and the Horizon Graphic are trademarks of DNV GL AS.

18 Approvals/approval marks



Job Id: **262.1-025494-2**
Certificate No: **TAA000014K**
Revision No: **1**

Product description

JUMO AQUIS touch P: Modular Multichannel Measuring Device for Liquid Analysis with Integrated Controller and Paperless Recorder (Type 202580)

Order code

202580 / x - xx - x - x - xx - xx - xx - xx - xx - xx / xxx
(1) / (2) - (3) - (4) - (5) - (6) - (7) - (8) - (9) - (10) - (11) / (12)

(1) Basic type

202580 JUMO AQUIS touch P

(2) Version

8 Standard with default settings
9 Customer-specific configuration (specification in plain text)

(3) National language

01 German
02 English
03 French

(4) Analysis input 1, IN 7

0 Not used
1 pH/redox/NH₃
2 CR conductive conductivity measurement (2 and 4-pole)
3 Ci inductive conductivity measurement

(5) Analysis input 2, IN 8

0 Not used
1 pH/redox/NH₃
2 CR conductive conductivity measurement (2 and 4-pole)
3 Ci inductive conductivity measurement

(6) Input/output 1 IN 11, OUT 6/7

00 Not used
10 Universal input
11 Relay (changeover contact)
12 2× relays (normally open contact)
13 Solid state relay triac 230V, 1A
14 Logic output 0/22V
15 2× logic outputs 0/12V
16 Analog output
17 2×solid state relay PhotoMOS®

(7) Input/output 2 IN 12, OUT 8/9

00 Not used
10 Universal input
11 Relay (changeover contact)
12 2× relays (normally open contact)
13 Solid state relay triac 230V, 1A
14 Logic output 0/22V
15 2× logic outputs 0/12V
16 Analog output
17 2×solid state relay PhotoMOS®
19 Power supply output DC±5V, 24V

18 Approvals/approval marks

Job Id: **262.1-025494-2**
Certificate No: **TAA000014K**
Revision No: **1**

(8) Input/output 3, IN 13/14/15, OUT 10/11

00 Not used
11 Relay (changeover contact)
12 2× relays (normally open contact)
13 Solid state relay triac 230V, 1A
14 Logic output 0/22V
15 2× logic outputs 0/12V
16 Analog output
17 2×solid state relay PhotoMOS®
18 3× digital inputs

(9) Input/output 4, IN 16/17/18, OUT 12/13

00 Not used
11 Relay (changeover contact)
12 2× relays (normally open contact)
13 Solid state relay triac 230V, 1A
14 Logic output 0/22V
15 2× logic outputs 0/12V
16 Analog output
17 2×solid state relay PhotoMOS®
18 3× digital inputs

(10) Voltage supply

23 AC110 to240V +10/-15%; 48to63Hz
39 AC/DC 24V +30/-25%; 48 to63 Hz

(11) COM2 interface COM 2

00 Not used
08 Ethernet
54 RS422/485 Modbus RTU
63 PROFINET IO
64 PROFIBUS-DP

(12) Extra codes

000 None
213 Recording function
214 Math and logic module
962 JUMO digiLine protocol activated

Electrical connection	In back via screw terminals
Data backup	Flash memory
Screen touchscreen	Type TFT, size 3.5", resolution 320x240pixel, color depth 256 colors

18 Approvals/approval marks

Job Id: **262.1-025494-2**
Certificate No: **TAA000014K**
Revision No: **1**

JUMO DICON touch: Two-Channel Process and Program Controller with Paperless Recorder and Touchscreen (Type 703571)

Order code

703571 / x - x - x x - x x x x x - x - x / x, x, x
(1) / (2) - (3) - (4) (5) - (6) (7) (8) (9) (10) - (11) - (12) / (13), (14), (15)

(1) Basic type

703571 JUMO DICON touch - two-channel process and program controller with RS485 interface

(2) Version

8 Standard with default settings
9 Customer-specific configuration (specifications in plain text)

(3) National language of display texts

01 German
02 English
03 French

(4) Input, IN10

00 Not used
10 Analog input (universal)

(5) Input, IN11

00 Not used
10 Analog input (universal)

(6) Outputs, OUT3/4

00 None
11 One relay (changeover contact)
12 Two relays (N/O contact)
13 One solid-state relay 230 V, 1 A
14 One logic output DC 0/22 V max. 30 mA
15 Two logic outputs 0/12 V, 20 mA
16 One analog output
17 Two PhotoMOS® relays
20 Two solid state relays 230 V, 1 A for motor actuator (double slot: OUT3/4 and OUT7/8)

(7) Outputs, OUT5/6

00 None
11 One relay (changeover contact)
12 Two relays (N/O contact)
13 One solid-state relay 230 V, 1 A
14 One logic output 0/22 V, max. 30 mA
15 Two logic outputs 0/12 V, 20 mA
16 One analog output
17 Two PhotoMOS® relays
20 Two solid state relays 230 V, 1 A for motor actuator (double slot: OUT5/6 and OUT9/10)

(8) Outputs, OUT7/8 (not available for assignment with module 20 on OUT3/4)

00 None
11 One relay (changeover contact)
12 Two relays (N/O contact)
13 One solid-state relay 230 V, 1 A
14 One logic output 0/22 V, max. 30 mA
15 Two logic outputs 0/12 V, 20 mA

18 Approvals/approval marks

Job Id: **262.1-025494-2**
Certificate No: **TAA000014K**
Revision No: **1**

16 One analog output
17 Two PhotoMOS® relays

(9) Outputs, OUT9/10 (not available for assignment with module 20 on OUT5/6)

00 None
11 One relay (changeover contact)
12 Two relays (N/O contact)
13 One solid-state relay 230 V, 1 A
14 One logic output 0/22 V, max. 30 mA
15 Two logic outputs 0/12 V, 20 mA
16 One analog output
17 Two PhotoMOS® relays

(10) Outputs, OUT11/12

00 None
11 One relay (changeover contact)
12 Two relays (N/O contact)
13 One solid-state relay 230 V, 1 A
14 One logic output 0/22 V, max. 30 mA
15 Two logic outputs 0/12 V, 20 mA
16 One analog output
17 Two PhotoMOS® relays

(11) Voltage supply

23 AC 110 to 240V +10/-15 %, 48 to 63 Hz
39 AC/DC 24V +30/-25 %, 48 to 63 Hz

(12) COM2 interface

00 Not used
08 Ethernet
54 RS422/485 Modbus RTU
63 PROFINET
64 PROFIBUS-DP

(13) DIN-tested

000 Without approval
056 With DIN approval

(14) GL-tested

000 Without approval
062 With GL approval

(15) Extra code

000 Without extra code
213 Recording function
214 Math and logic module
223 Program controller
879 AMS2750/CQI-9

Electrical connection	In back via screw terminals
Screen touchscreen	Type TFT, size 3.5", resolution 320x240pixel, color depth 256 colors

Place of manufacture

JUMO GmbH & Co. KG
Moritz-Juchheim-Straße 1
36039 Fulda, Germany

18 Approvals/approval marks

Job Id: **262.1-025494-2**
Certificate No: **TAA000014K**
Revision No: **1**

Application/Limitation

The Type Approval covers hardware listed under Product description.
When the hardware is used in applications to be classed by DNV GL, documentation for the actual application is to be submitted for approval by the manufacturer of the application system in each case. Reference is made to DNV GL RU SHIP Pt.4 Ch.9 Sec. 1.

Type Approval documentation

Test Reports:

Overview document "Prüfprotokolle DNVGL DICON Touch_Aquis Touch P", Vers.08, dated 2018-11-26

Product documents:

AQUIS touch P:

Operating Manual 20258000T90Z001K000 (V6.00/EN/00607974),
Data Sheet 202580 (V5.01/EN/00601344),
Drawing AQUIS touch P 20258000A00Z000K000, dated 2018-01-22;
Diagram composition AQUIS Touch P, 20258000C40Z000K000, dated 2018-08-29.

DICON touch:

Operating Manual 70357100T90Z004K000 (V1.01/EN/00603327),
Data Sheet 703571 (V1.00/EN/00578870),
Drawing DICON touch 70357100A00Z000K000, dated 2018-01-22;
Diagram composition DICON Touch, 70357100C40Z000K000, dated 2018-08-29.

Impact analysis CPU 2_70357100C50Z024 (Version 1.00/28.04.2016)
Impact analysis Display 2_70357100C50Z026 (Version 1.00/29.04.2016)
DNVGL-Einflussanalyse JUMO AQUIS touch P, V1.00, dated 2017-03-24.

Tests carried out

Applicable tests according to Class Guideline DNVGL-CG-0339, Edition November 2016.

Marking of product

The products to be marked with:

- manufacturer name
- serial number
- type 202580 or 703571.

Periodical assessment

The scope of the periodical assessment is to verify that the conditions stipulated for the type are complied with, and that no alterations are made to the product design or choice of systems, software versions, components and/or materials.

The main elements of the assessment are:

- Ensure that type approved documentation is available
- Inspection of factory samples, selected at random from the production line (where practicable)
- Review of production and inspection routines, including test records from product sample tests and control routines
- Ensuring that systems, software versions, components and/or materials used comply with type approved documents and/or referenced system, software, component and material specifications
- Review of possible changes in design of systems, software versions, components, materials and/or performance, and make sure that such changes do not affect the type approval given
- Ensuring traceability between manufacturer's product type marking and the type approval certificate

Periodical assessment is to be performed after 2 years and after 3.5 years. A renewal assessment will be performed at renewal of this certificate.

END OF CERTIFICATE

18.2 DIN



ZERTIFIKAT

Zertifikatinhaber	JUMO GmbH & Co. KG Moritz-Juchheim-Str. 1 36039 Fulda
Produkt	Temperaturregel- und Begrenzungseinrichtungen für Wärme
Typ, Modell	JUMO DICON Touch (Typ 703571)
Prüfgrundlage(n)	DIN EN 14597:2015-02 Zertifizierungsprogramm Temperaturregel- und -begrenzungs- wärmeerzeugende Anlagen (2009-01)
Konformitätszeichen	
Registernummer	TR1238
Gültig bis	2020-07-31
Nutzungsrecht	Dieses Zertifikat berechtigt zum Führen des oben stehenden I in Verbindung mit der genannten Registernummer. Weitere Angaben siehe Anhang.

DIN CERTCO

Gesellschaft für Konformitätsbewertung mbH

ZERTIFIKAT

Zertifikatinhaber	JUMO GmbH & Co. KG Moritz-Juchheim-Str. 1 36039 Fulda
Produkt	Temperaturregel- und Begrenzungseinrichtungen für Wärmee
Typ, Modell	JUMO DICON Touch (Typ 703571)
Prüfgrundlage(n)	DIN EN 14597:2015-02 Zertifizierungsprogramm Temperaturregel- und -begrenzungse wärmeerzeugende Anlagen (2009-01)
Konformitätszeichen	
Registernummer	TR1238
Gültig bis	2020-07-31
Nutzungsrecht	Dieses Zertifikat berechtigt zum Führen des oben stehenden K in Verbindung mit der genannten Registernummer. Weitere Angaben siehe Anhang.

部件名称 Product group: 703571	有毒有害物质或元素 Hazardous substances					
	铅 (Pb)	汞 (Hg)	镉 (Cd)	六价铬 (Cr(VI))	多溴联苯 (PBB)	多溴二苯醚 (PBDE)
外壳 Housing (Gehäuse)	X	○	○	○	○	○
过程连接 Process connection (Prozessanschluss)	○	○	○	○	○	○
螺母 Nut (Mutter)	○	○	○	○	○	○
螺钉 Screw (Schraube)	○	○	○	○	○	○

本表格依据 SJ/T 11364-2014 的规定编制。
 (This table is prepared in accordance with the provisions of SJ/T 11364-2014.)
 O : 表示该有害物质在该部件所有均质材料中的含量均在 GB/T 26572 规定的限量要求以下。
 (O: Indicates that said hazardous substance contained in all of the homogeneous materials for this part is below the limit requirement of GB/T 26572.)
 X : 表示该有害物质至少在该部件的某一均质材料中的含量超出 GB/T 26572 规定的限量要求。
 (X: Indicates that said hazardous substance contained in one of the homogeneous materials used for this part is above the limit requirement of GB/T 26572.)



JUMO GmbH & Co. KG

Street address:

Moritz-Juchheim-Straße 1
36039 Fulda, Germany

Delivery address:

Mackenrodtstraße 14
36039 Fulda, Germany

Postal address:

36035 Fulda, Germany
Phone: +49 661 6003-0
Fax: +49 661 6003-607
Email: mail@jumo.net
Internet: www.jumo.net

JUMO Instrument Co. Ltd.

JUMO House

Temple Bank, Riverway
Harlow, Essex, CM20 2DY, UK

Phone: +44 1279 63 55 33

Fax: +44 1279 62 50 29

Email: sales@jumo.co.uk

Internet: www.jumo.co.uk

JUMO Process Control, Inc.

6733 Myers Road
East Syracuse, NY 13057, USA

Phone: +1 315 437 5866

Fax: +1 315 437 5860

Email: info.us@jumo.net

Internet: www.jumousa.com

