

## JUMO safetyM STB/STW Ex

Safety temperature limiter, safety temperature monitor according to DIN EN 14597 and ATEX and other measured values



Type 701 155/8 ... 044      Type 701 155/8 ... 045

**Operating manual**  
(English translation of the  
original German manual)

**70115500T90Z001K000**

**JUMO**

V6.00/EN/00542382/2025-05-05

# Operating overview

Normal display (approx. 5 secs after switch-on)

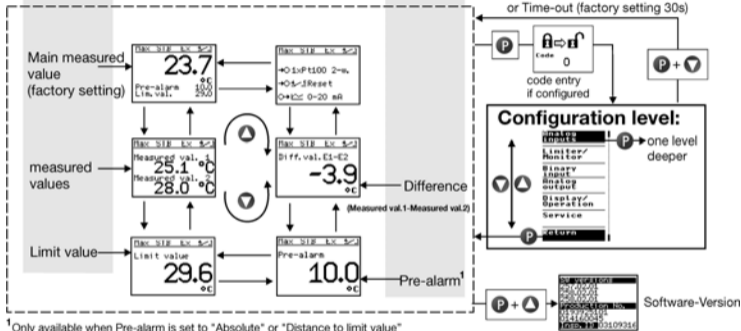

# Content

---

	<b>Operating overview</b> .....	<b>2</b>
<b>1</b>	<b>Brief description</b> .....	<b>12</b>
1.1	Marking according to ATEX .....	12
1.2	Marking according to IECEx .....	13
1.3	Ignition source monitoring .....	13
1.4	Safety temperature monitor (STW) .....	14
1.5	Safety temperature limiter (STB) .....	14
1.6	Safety information .....	15
1.7	Safety .....	15
<b>2</b>	<b>Identifying the device version</b> .....	<b>16</b>
2.1	Changing the default switching behavior .....	17
2.2	Scope of delivery .....	20
2.3	Device software versions .....	20
2.4	Fabrication number .....	20
2.5	Service addresses .....	20
2.6	Approvals .....	21
<b>3</b>	<b>Mounting</b> .....	<b>25</b>
3.1	Dimensions .....	25
3.2	Mounting site, DIN-rail mounting .....	26
3.3	Close mounting .....	26
3.4	Dismounting .....	27
3.5	Galvanic isolation .....	28
3.6	Use of the setup interface .....	28

<b>4</b>	<b>Electrical connection</b>	<b>29</b>
4.1	Installation notes	29
4.2	Removing the cover cap	30
4.3	Connection diagram	31
4.4	Checking the wiring of the intrinsically safe electrical circuit	35
<b>5</b>	<b>Startup of the device</b>	<b>36</b>
5.1	Display and control elements	36
5.2	Setting the display after device is switched on	36
5.3	Selecting and editing parameters (plausibility requirement for input values)	38
5.4	Canceling edit	39
5.5	Acknowledging alarms using the reset key (for temperature limiter STB only)	39
5.6	Acknowledging alarms using the digital input (for temperature limiter STB only)	39
5.7	Functional test	40
5.8	Sealing the device	41
<b>6</b>	<b>Safety Manual</b>	<b>42</b>
6.1	Brief description	42
6.2	Safety temperature monitor (STW)	43
6.2.1	Safe operating status of STW	43
6.3	Safety temperature limiter (STB)	43
6.3.1	Safe operating status of STB	43
6.6	Sensor connection possibilities (SIL)	45
6.7	Standards and definitions	48
6.8	Safety instrumented parameters related to the temperature monitoring unit	52
6.8.1	Failure rates and SFF for type 701155/X-XX-025X-XXXX-23... (AC 230 V)	52

# Content

---

6.8.2	Failure rates and SFF for type 701155/X-XX-025X-XXXX-25 (AC/DC 24 V) .....	53
6.9	Determining the safety integrity level (SIL) .....	54
6.9.1	Safety integrity of the hardware .....	56
6.9.2	Safety-relevant system properties .....	57
6.10	Determining the achieved performance level PL .....	59
6.11	Sensor connection possibilities (PL) .....	62
6.11.1	Calculations DIN EN ISO 13849-1 Performance Level – low voltage 230 V .....	64
6.11.2	Calculations DIN EN ISO 13849-1 Performance Level – extra low voltage (ELV) 24 V .....	64
6.11.3	Contribution to risk reduction by the control system .....	65
6.12	Performance Level .....	67
6.13	Correlation between the Performance Level (PL) and Safety Integrity Level (SIL) .....	67
6.14	Other applicable device documentation .....	69
6.15	Behavior during operation and in case of malfunction .....	69
6.16	Regular tests .....	70
6.16.1	Recommended tests for temperature probes .....	70
<b>7</b>	<b>ATEX ignition protection type "i" .....</b>	<b>72</b>
7.1	Intended use .....	72
7.1.1	<b>Installation regulations .....</b>	<b>73</b>
7.2	Identification marking according to ATEX directive 2014/34/EU and EN standards EN 60079-11 "i", EN 50495, and EN ISO 80079-37 "h":74	
7.3	Meaning of the X character in the type examination certificate .....	77
7.4	Associated, intrinsically safe electrical apparatus according to EN 60079-11 .....	78
7.4.1	Function of intrinsic safety .....	78
7.4.1.1	Definitions of intrinsic safety .....	78
7.4.1.2	<b>Electrical apparatus .....</b>	<b>78</b>

7.4.1.3	<b>Intrinsically safe electrical apparatus</b> .....	<b>78</b>
7.4.1.4	<b>Associated electrical apparatus</b> .....	<b>78</b>
7.4.2	Probe arrangement in the Ex-area .....	80
7.4.3	Explanation of probe temperature classes .....	82
7.5	Safety device according to DIN EN 50495 .....	84
7.5.1	Temperature monitoring unit based on the ignition protection type "e", increased safety, according to EN 60079-7 ..	84
7.5.1.1	<b>Function of increased safety</b> .....	<b>84</b>
7.5.1.2	<b>Use in the 1-sensor variant.</b> .....	<b>85</b>
7.5.1.3	<b>Use in the 2-sensor variant.</b> .....	<b>85</b>
7.5.1.4	<b>Use of temperature transmitters</b> .....	<b>86</b>
7.6	Ignition source monitoring "h" according to EN ISO 80079-37 .....	87
7.6.1	Ignition source monitoring „b“ .....	87
7.6.2	Ignition protection system types .....	87
7.6.3	Application of the ignition protection system types .....	87
7.6.4	Identification marking .....	87
<b>8</b>	<b>ATEX ignition protection type "e" and "t"</b> .....	<b>88</b>
8.1	Intended use .....	88
8.2	Identification marking according to ATEX directive 2014/34/EU and according to the standards EN 60079-7 "e" and EN 60079-31 "t":	89
8.3	Meaning of the X character in the type examination certificate .....	90
8.3.1	Probe arrangement in the Ex-area .....	90
<b>9</b>	<b>IECEx</b> .....	<b>92</b>
9.1	Intended use .....	92
9.2	Marking according to IECEx ignition protection type "ia": .....	92
9.3	Marking according to IECEx ignition protection type „h“ .....	93

# Content

---

9.4	Marking according to IECEx Zündschutzart „d, e, h“ und „t“	94
9.5	Excerpt of important device data.	94
<b>10</b>	<b>Configuration level</b>	<b>98</b>
10.1	Navigation principle	98
10.2	Analog inputs	99
10.2.1	Connection	99
10.2.2	Probe type 1	100
10.2.3	Offset 1	101
10.2.4	Resistivity 1	101
10.2.5	Filter time 1	102
10.2.6	Scaling start 1	102
10.2.7	Scaling end 1	102
10.2.8	Probe type 2	103
10.2.9	Offset 2	104
10.2.10	Resistivity 2	104
10.2.11	Filter time 2	105
10.2.12	Scaling start 2	105
10.2.13	Scaling end 2	105
10.3	Limiter/monitor	106
10.3.1	Device function	106
10.3.2	Switching behavior	107
10.3.3	Limit value, hysteresis	109
10.3.4	Pre-alarm function	109
10.3.5	Pre-alarm, hysteresis	117
10.3.6	Error Pre-alarm, Relay pre-alarm	117
10.3.7	Limit value difference, hysteresis	117

10.3.8	Setting range min. (formerly ALHI) .....	118
10.3.9	Setting range max. (formerly ALLO) .....	118
10.4	Binary input .....	119
10.4.1	Function. ....	119
10.5	Analog output. ....	120
10.5.1	Function. ....	120
10.5.2	Signal type. ....	120
10.5.3	Scaling start. ....	120
10.5.4	Scaling end .....	120
10.5.5	Error cases .....	121
10.5.6	Error signal .....	121
10.5.7	Behavior when leaving the scaling range .....	122
10.6	Display/operation .....	123
10.6.1	Language. ....	123
10.6.2	Unit .....	123
10.6.3	Decimal place .....	123
10.6.4	Normal display. ....	123
10.6.5	Contrast. ....	124
10.6.6	Backlight .....	124
10.6.7	Time-out light .....	124
10.6.8	Time-out operation .....	124
10.6.9	Code .....	124
10.7	Service .....	125
10.7.1	Limit switching cycle .....	125
10.7.2	Current switching cycles .....	125
10.7.3	Operating hours. ....	125

# Content

---

<b>11</b>	<b>Technical data</b>	<b>126</b>
11.1	Analog inputs	126
11.2	Analog output	128
11.3	Digital input	128
11.4	Relay outputs	129
11.5	Measuring circuit monitoring	130
11.6	Voltage supply	130
11.7	Test voltages according to EN 60730, Part 1	131
11.8	Electrical safety	131
11.9	Environmental influences	131
11.10	Housing	132
11.11	Note about the probes in Chapter to Chapter 11.12	133
11.11.1	Instructions for replacing protective sleeves or sensors	133
11.11.2	Further connection options	133
11.12	Probes for the operating medium air	134
11.13	Probes for water and oil	136
11.14	Probes for air, water, and oil	138
<b>12</b>	<b>Setup program</b>	<b>139</b>
12.1	Minimum hardware and software requirements:	139
12.2	Displaying the device software version	139
12.3	Forgotten the code?	140
12.4	Special function: thermocouple reverse-polarity protection	140
12.5	Displaying a pressure signal via the current input	141
12.5.1	Configuration of a pressure signal using the setup program	142

<b>13</b>	<b>Alarm messages</b> .....	<b>145</b>
<b>14</b>	<b>Error messages</b> .....	<b>146</b>
<b>15</b>	<b>What to do, if ...</b> .....	<b>151</b>
<b>16</b>	<b>Information for devices with extra code 062 DNV GL</b> .....	<b>153</b>
16.1	Technical data .....	153
16.2	Alarm messages .....	153
16.3	Locks .....	153
<b>17</b>	<b>Behavior of outputs</b> .....	<b>155</b>
<b>18</b>	<b>Certificates</b> .....	<b>158</b>
18.1	SIL und PL .....	158
18.2	ATEX TÜV Nord .....	160
18.3	ATEX eurofins .....	166
18.4	IECEX TÜV Nord .....	170
18.5	IECEX eurofins .....	179
18.6	EU declaration of conformity .....	184
18.7	UKEX (EPS 22 UKEX 1 107 X) .....	191
18.8	UKEX (EPS 22 UKEX 2 108 X) .....	194
18.9	UK Conformity .....	200
18.10	China RoHS .....	205

## Content

---

## 1 Brief description

The device is tested according to ATEX directive 2014/34/EU as associated apparatus with intrinsic safety "i", increased safety "e", and protection by housing "t".

It meets the requirements of the following identification markings:

### 1.1 Marking according to ATEX



II (1) G [Ex ia Ga] IIC	<b>according to EN 60079-0; -11; -26</b>
II (1) D [Ex ia Da] IIIC	



II (2) G [Ex eb Gb] IIC	<b>according to EN 50495 according to EN 60079-7</b>
-------------------------	--



II (1) D [Ex ta Da] IIIC	<b>according to EN 50495 according to EN 60079-31</b>
II (2) D [Ex tb Db] IIIC	



II (2) G [Ex db Gb] IIC	<b>according to EN 50495 according to EN 60079-1</b>
-------------------------	--



II (1) G [Ex h Ga] IIC	<b>according to EN 50495 according to EN 60079-37</b>
II (1) D [Ex h Da] IIIC	

## 1.2 Marking according to IECEx



[Ex ia Ga] IIC	<b>according to IEC 60079-11</b>
[Ex ia Da] IIIC	



[Ex h Ga] IIC	<b>according to IEC 80079-37</b>
[Ex h Da] IIIC	

## 1.3 Ignition source monitoring

The device is also certified for use according to DIN EN 50495 and DIN EN ISO 80079-37 as an ignition source monitor as specified in the ATEX directive.

The compact and user configurable STB/STW according to ATEX requirements can now also enable early and reliable detection of risks in Ex-areas which could potentially result in personal injuries, environmental damage, or destruction of production plants and production materials.

The task of safety temperature limiters is to reliably monitor thermal processes and to switch plants to a safe operating status in the event of malfunctions.

Along with the existing approvals according to DIN 14597, SIL 3, PL e (Performance Level), GL, the device also has approval according to ATEX and can therefore also be used for measurements in Ex-areas. However, the device itself has to be installed outside the Ex-area.

The inputs are suitable for applications requiring intrinsic safety and increased safety, meaning that relevant probes can be connected directly.

Barriers are no longer required.

The device is also certified according to DIN EN 50495 and DIN EN ISO 80079-37 as an ignition source monitor (IPL 2) as specified in the ATEX directive and can be used to monitor potentially explosive atmospheres containing gas or dust.

The device concept also meets the stringent requirements of DIN EN 61508 and DIN EN 13849. The 1oo2D structure ensures reliable detection of errors, meaning that the device concept can also be used for applications subject to the new Machinery Directive 2006/42/EC.

The measured value at the analog input can be recorded by various probes or standard signals.

If the measured value exceeds the limit value, this is indicated by the installed LEDs K1 and K2 (red) for each channel, and the installed alarm relay output switches the plant to a safe operating status (**alarm range**).

Other measured variables, such as pressure, can also be safely switched off via connection variant 5.

⇒ Chapter 6.8 and Chapter 6.11

## 1.4 Safety temperature monitor (STW)

The STW is a safety-component device according to the Machinery Directive which, when activated, resets automatically if the probe temperature has fallen below or risen above the set limit value by an amount equal to the switching differential. Possible settings: monitoring for limit value overrange or underrange.

⇒ Chapter 10.3.2 "Switching behavior"

## 1.5 Safety temperature limiter (STB)





The STB is a safety-component device according to the Machinery Directive which is permanently locked after activation. A manual reset using the  (RESET) key is only possible once the probe temperature has fallen below/has exceeded the limit value by the amount of the switching differential. Possible settings: monitoring for limit value overrange or underrange.

⇒ Chapter 10.3.2 "Switching behavior"

The transparent, sealable protective cover prevents unauthorized operation.

However, the  (RESET) key is still accessible.

## 1.6 Safety information

Symbol	Meaning	Explanation
	Note	This symbol is used to draw your attention to a <b>particular issue</b> .
	Attention	This symbol is used when <b>damage to devices or data</b> may occur if the instructions are disregarded or not followed correctly!
	Caution	This symbol is used when <b>personal injury</b> may occur if the instructions are disregarded or not followed correctly!
	Read	This text contains important information which must absolutely be read before proceeding. Manipulations not described in the operating manual or which are expressly forbidden will jeopardize your warranty rights.
	Reference	This symbol refers to further information in other manuals, chapters, or sections.
abc <sup>1</sup>	Footnote	Remarks at the end of a page that <b>refer to</b> specific text passages and are marked with a number placed in superscript.
*	Action instruction	This symbol marks the description of a <b>required action</b> . The individual steps are marked by this asterisk.

## 1.7 Safety

The device does not implement any "network and system security" measures according to the IEC 62443 standards series. This means that the JUMO STB/STW series only consider the "safety" aspect.

## 2 Identifying the device version

Exemplary illustration of the type plate, which is glued on the side of the device.

Voltage supply AC  
110 to 240 V:

JUMO GmbH & Co. KG 36039 Fulda, Germany  
www.jumo.net

JUMO safetyM STB/STW Ex

Typ: 701155/8-01-0253-2001-23-044-005/059

STB "O" SW: 123.12.1\*

2x Pt100 dl

3A, 230VAC - ohm. Last

AC 110...240V, +10/-15%, 48...63Hz, 12VA







STB/STW1228

F-Nr: 0000000001001010000 TN: 00572503

Voltage supply AC/DC  
20 to 30 V:

JUMO GmbH & Co. KG 36039 Fulda, Germany  
www.jumo.net

JUMO safetyM STB/STW Ex

Typ: 701155/8-01-0253-2001-25-044-005/059

STB "O" SW: 123.12.1\*

2x Pt100 dl

3A, 230VAC - ohm. Last

AC/DC 20...30V, 48...63Hz, 12VA







STB/STW1228

F-Nr: 0000000001001010000 TN: 00572502

### Ex i identification marking

JUMO GmbH & Co. KG 36039 Fulda, Germany  
www.jumo.net

JUMO safetyM STB/STW Ex



II (1) G [Ex ia Ga] IIC II (1) D [Ex ia Da] IIC  
II (1) D [Ex ia Da] IIC II (2) D [Ex ib Db] IIC  
II (2) G [Ex eb Gb] IIC II (2) G [Ex db Db] IIC  
II (1) G [Ex h Gb] IIC II (1) D [Ex h Da] IIC  
TUV 11 ATEX 556139 X



[Ex ia Ga] IIC [Ex ia Da] IIC  
[Ex h Ga] IIC [Ex h Da] IIC  
IECEx TUN 15.0036X



Klemmen / Terminals / Borne 1, 2, 3, 6, 7, 8:

U<sub>i</sub> = 6.0 V C<sub>i</sub> = 36.3 µF \*  
I<sub>n</sub> = 41.2 mA L<sub>n</sub> = 20 mH \*  
P<sub>n</sub> = 61.8 mW \*  
0°C ≤ Ta ≤ +55°C \* see certificate



### Ex e and Ex t identification marking

JUMO GmbH & Co. KG 36039 Fulda, Germany  
www.jumo.net

JUMO safetyM STB/STW Ex



II (2) G [Ex eb Gb] IIC II (2) D [Ex ib Db] IIC  
II (2) G [Ex db Db] IIC  
II (2) G [Ex h Gb] IIC II (2) D [Ex h Db] IIC



SEV 17 ATEX 0161 X  
IECEx SEV 22.0016 X



Klemmen / Terminals / Borne 1, 2, 3, 6, 7, 8:

U<sub>i</sub> = 6.0 V  
I<sub>n</sub> = 41.2 mA  
P<sub>n</sub> = 61.8 mW  
0°C ≤ Ta ≤ +55°C

The voltage supply that is connected must correspond to the voltage specified on the nameplate!



## 2.1 Changing the default switching behavior

If the safety function used according to EN 14597 is changed to, e.g., STW with max. alarm, this should be indicated accordingly on the nameplate. This can be noted manually on the nameplate directly below the order code, for example.

**Example:** Changing a supplied STB with max. alarm (code 0253) to an STW with max. alarm (code 251) should be noted.

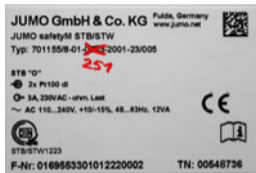

701155

**Basic type**

Safety temperature limiter / safety temperature monitor (STB)/(STW) Ex with SIL, PL, and IPL approval

**Version**

Default setting

Configured according to customer specifications

**National language**

German (default setting)

English

French

**Switching behavior**

0251 Safety temperature monitor max. alarm [inverse, opening function]

0252 Safety temperature monitor min. alarm [direct, closing function]

0253 Safety temperature limiter max. alarm [inverse, opening function] (default setting)

0254 Safety temperature limiter min. alarm [direct, closing function]

**Measurement input<sup>1</sup> (programmable)**

1003 1x Pt100 in 2-wire circuit

2001 2x Pt100 in 3-wire circuit (default setting)

2003 2x Pt100 in 2-wire circuit

2005 2x Pt1000 in 2-wire circuit

2006 2x Pt1000 in 3-wire circuit

2036 2x W5Re-W26Re "C"

2037 2x W3Re-W25Re "D"

2039 2x Cu-CuNi "T"

2040 2x Fe-CuNi "J"

2041 2x Cu-CuNi "U"

2042	2x Fe-CuNi "L"
2043	2x NiCr-Ni "K"
2044	2x Pt10Rh-Pt "S"
2045	2x Pt13Rh-Pt "R"
2046	2x Pt30Rh-Pt6Rh "B"
2048	2x NiCrSi-NiSi "N"
1053	1x 4 to 20 mA
2053	2x 4 to 20 mA

---

#### Voltage supply

23	AC 110 to 240 V +10 % /-15 %, 48 to 63 Hz
25	AC/DC 20 to 30 V, 48 to 63 Hz

---

#### Ignition protection type

044	[Ex ia] associated apparatus "i", installation outside the Ex-area
045	[Ex eb, tb] associated apparatus, "e" for gas, "t" for dust, installation outside the Ex-area

---

#### Analog output (configurable)

001	0 to 20 mA
005	4 to 20 mA (default setting)
040	0 to 10 V
070	2 to 10 V

---

#### Extra code

059	There is always SIL, PL, and IPL approval
062	GL approval
085	UKEX approval

701155/ 8 - 01 - 0253 - 2001 - 23 - 044 - 005/ , 062

1. The first number on the measurement input means single probe "1" or double probe "2"

## 2.2 Scope of delivery

- JUMO safetyM STB/STW Ex in the ordered version
- Operating manual
- ATEX cover cap for measurement inputs

## 2.3 Device software versions

Diagnostics module version: 257.02.01  
 Analog channel 1 version: 258.02.01  
 Analog channel 2 version: 258.02.01



```
SW-Versionen
257.02.01
258.02.01
258.02.01
Fabrikationsnr.
0193925101
014160045
Prüf-Nr 03109316
```

## 2.4 Fabrication number

The fabrication number is displayed on the device.

\* Press **P** + **A** keys

Structure:

The first 8 digits are the production order number: 01939251  
 Digit 9 and 10 Fulda manufacturing site: 01  
 Digit 11 (second row) hardware version: 0  
 Digit 12 and 13 year: 2014  
 Digit 14 and 15 calendar week: 16  
 Digit 16 to 19 consecutive number: 0045











```
SW-Versionen
257.02.01
258.02.01
258.02.01
Fabrikationsnr.
0193925101
014160045
Prüf-Nr 03109316
```



## 2.5 Service addresses

See back cover

## 2.6 Approvals

	Designation Testing agency Certifikate no. Inspection basis Valid for	DIN DIN CERTCO STB/STW1228 DIN EN 14597 All device versions
	Designation Testing agency Certifikate no. Inspection basis Valid for	SIL2, SIL3 TÜV Nord SEBS-A.102606/16-2 V1.0 DIN EN 61508, DIN EN 60730-2-9, DIN EN 14597 All device versions
	Designation Testing agency Certifikate no. Inspection basis Valid for	PL e TÜV Nord SEBS-A.102606/16-2 V1.0 DIN EN ISO 13849-1 All device versions
	Designation Testing agency Certifikate no. Inspection basis Valid for	DNV DNV TAA000017J DNV rules for classification - Ships, offshore units, and high speed and light craft Only devices with extra code 062

	<p>Designation Testing agency Certifikate no. Inspection basis Valid for</p>	<p>ATEX „i“ TÜV Nord TÜV 11 ATEX 556139 X Directive 2014/34/EU Devices with blue terminals, Ignition protection level 044</p>
	<p>Designation Testing agency Certifikate no. Inspection basis Valid for</p>	<p>ATEX „e“ und „t“ Eurofins / Electrosuisse Product Testing AG SEV 17 ATEX 0161 X Directive 2014/34/EU Devices with black terminals, Ignition protection level 045</p>
	<p>Designation Testing agency Certifikate no. Inspection basis Valid for</p>	<p>IECEx „i“ TÜV Nord IECEx TUN 15.0036X IEC 60079-0, IEC 60079-11, IEC 80079-36, IEC 80079-37 Devices with blue terminals, Ignition protection level 044</p>
	<p>Designation Testing agency Certifikate no. Inspection basis Valid for</p>	<p>IECEx „e“ and „t“ Eurofins Electrosuisse Product Testing AG IECEx SEV 22.0016X IEC 60079-0, IEC 60079-7, IEC 60079-31, IEC 80079-36, IEC 80079-37 Devices with black terminals, Ignition protection level 045</p>

	<p>Designation</p> <p>Testing agency</p> <p>Certifikate no.</p> <p>Inspection basis</p> <p>Valid for</p>	<p>UKCA</p> <p>Bureau Veritas</p> <p>EPS 22 UKEX 2 108 X</p> <p>EN IEC 60079-0:2018, EN IEC 60079-11:2012, EN 50495:2010 EN ISO 80079-36:2016, EN ISO 80079-37:2016</p> <p>Devices with blue terminals, Ignition protection level 044, extra code 085</p>
	<p>Designation</p> <p>Testing agency</p> <p>Certifikate no.</p> <p>Inspection basis</p> <p>Valid for</p>	<p>UKCA</p> <p>Bureau Veritas</p> <p>EPS 22 UKEX 1 107 X</p> <p>EN IEC 60079-0:2018, EN IEC 60079-7:2015/A1 :2018, EN 60079-31 :2014 EN ISO 80079-36:2016, EN ISO 80079-37:2016 EN 50495:2010, EN 60079-1 :2014</p> <p>Devices with black terminals, Ignition protection level 045, extra code 085</p>



This operating manual is the translation of the **German manual**.

It is valid for the following hardware and software versions:

Diagnostics module as of version: 257.02.01

Analog channel 1 as of version: 258.02.01

Analog channel 2 as of version: 258.02.01

and replaces the following older versions:

Diagnostics module version: 257.01.XX

Analog channel 1 version: 258.01.XX

Analog channel 2 version: 258.01.XX

The following versions are already available:

b70.1155: 2013-04-01 A400

b70.1155: 2013-04-01 A401

b70.1155: 2015-06-01 A402

b70.1155: 2016-02-01 A403

70115500T90Z000K000: V1.01

\* Press  +  keys

Keep the operating manual in a place that is accessible to all users at all times.



All the necessary settings are described in the operating manual.

Manipulations that are not described in the operating manual or which are expressly forbidden will jeopardize your warranty rights and may render the safety function inoperative!

Any interference with the inside of the device is prohibited!

Repairs may only be performed by JUMO in the company's headquarters in Fulda.

If you have any problems, please contact the nearest branch office or the head office.

### 3 Mounting

#### 3.1 Dimensions

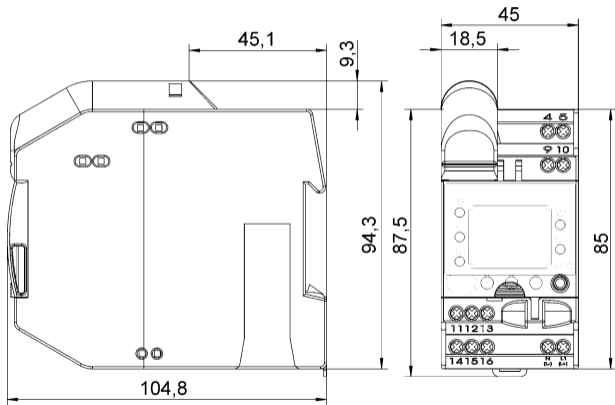

### 3.2 Mounting site, DIN-rail mounting



The device is not suitable for installation in potentially explosive areas.  
The device is clipped to a 35 mm DIN rail (DIN EN 60715) from the front and locked into place by pressing downwards.

⇒ The ambient conditions at the mounting site must meet the requirements specified in the technical data.

Chapter 11 "Technical data"

- Should be as vibration-free as possible to prevent the screw connections from working loose!
- Should be free from aggressive media (e.g. strong acids and lyes), and as free as possible from dust, flour, or other suspended solids to prevent the cooling slots from being blocked!

### 3.3 Close mounting

- Maintain the minimum distance of 20 mm to the top and the bottom.
  1. So that the release slot can still be accessed with a screwdriver from the bottom.
  2. So that when dismantling, the device can be swiveled upwards and removed from the DIN rail.
- Several devices can be mounted right next to one another without a minimum distance.



### 3.4 Dismounting

- \* Place screwdriver in release catch at bottom and press upward (1).
- \* Swivel screwdriver and housing upwards at the same time out of the DIN rail (2).

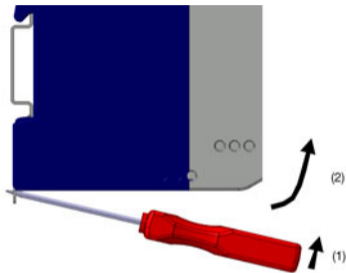

### 3.5 Galvanic isolation

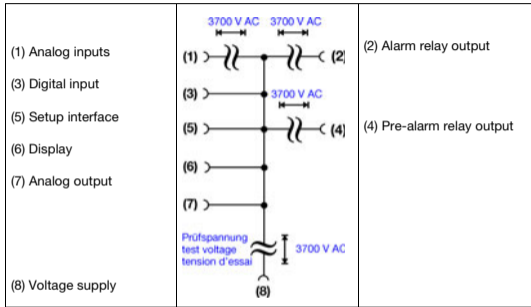

### 3.6 Use of the setup interface

- The USB setup interface is only designed for service use over a limited period (such as the transfer of setup data or during startup).
- The USB setup interface is not suited for perpetual operation in a hard-wired plant because the monitoring function is deactivated during data transfer with the setup program!

## 4 Electrical connection

### 4.1 Installation notes

- Check to see if the safety temperature limiter is installed in a manner appropriate to the application (temperature measurement) and that it is operated within the admissible plant parameters.
- The device is intended to be installed in control cabinets, machines, or plants. Ensure that the customer's fuse protection does not exceed 20 A.
- Disconnect the device from the mains voltage on all poles prior to starting service or repair work.
- All incoming and outgoing lines without a connection to the power supply network must be laid with shielded and twisted lines. The shield must be grounded on the device side.
- Do not lay the input and output cables close to components or lines through which current is flowing.
- Do not connect any additional loads to the screw terminals for the voltage supply of the device.
- Both the choice of cable material for the installation, as well as the electrical connection of the device must conform to the local requirements of VDE 0100 "Regulations on the Installation of Power Circuits with Nominal Voltages below 1000 V" or the appropriate regulations for the country.
- Suitable measures must be taken to protect the relay circuit.  
The maximum switching capacity is 230 V/3 A (resistive load).
- The electromagnetic compatibility conforms to the standards and regulations cited in the technical data.  
⇒ Chapter 11 "Technical data"
- For startup we recommend that a trial run of the plant up to the temperature shutoff at the set limit is carried out.



#### Hybrid mixtures:

If a dangerous atmosphere could occur at the mounting site – an atmosphere that is potentially explosive due to a mixture of gases, steam, or mist and at the same time through combustible dusts – then the safety-related characteristic parameters of the gases, steam, or mist and the combustible dusts can change. In such cases the suitability of the intended device is to be checked by an appropriate expert body.



The electrical connection and the configuration settings up to the startup must only be carried out by qualified personnel.



The approval according to DIN EN 14597 is only valid when the correct probe is set in the configuration level and if the probe is connected.

The limit value to be monitored must lie in the admissible temperature range of the DIN probes!

⇒ Chapter 11.12 "Probes for the operating medium air" to Chapter 11.14 "Probes for air, water, and oil"

The monitoring function is deactivated while data is transmitted over the setup program.

⇒ Chapter 15 "What to do, if ..."

## 4.2 Removing the cover cap

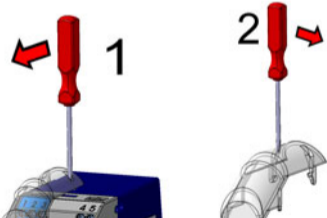
1	* Insert the screwdriver into the right opening of the cover cap and pry up to the left.	
2	* Hold the cover cap and pry up the second catch in the left opening to the right	

### 4.3 Connection diagram

The connection is made via screw terminals.











**Attention:**









The cover cap must be removed prior to wiring and put back on when finished.





This is necessary for the proper operation of the probes in the Ex-area!

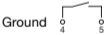

Wire	Admissible cross section
One-wire	$\leq 2.5 \text{ mm}^2$
Fine-strand, with ferrule	$\leq 1.5 \text{ mm}^2$
Tightening torque of the screws: max. 0.5 Nm	

Legend	Comment	Screw terminals	Screw terminals
1, 2		Analog input 1 (E1)	Analog input 2 (E2)
	Thermocouple / <b>Double thermocouple</b>		
	 <p>When connecting double thermocouples, the measuring circuits (E1) and (E2) must be isolated. That means that both thermocouples have no electrical connection to the protection fitting and furthermore no electrical connection to each other (isolated assembly).</p>		
	<b>RTD temperature probe Pt100/Pt1000 in two-wire circuit</b>		
	 <p>Enter the line resistance for RTD temperature probes in two-wire circuit when using greater line lengths. ⇒ Setup program: <i>analog inputs</i></p>		
	<b>RTD temperature probe Pt100/Pt1000 in three-wire circuit</b>		

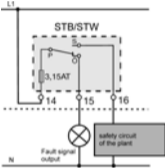
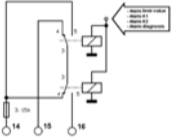
Legend	Comment	Screw terminals	Screw terminals
	<p>RTD temperature probe Pt100 in two-wire circuit, single sensor for both analog inputs</p> <p><b>Attention:</b> When only one probe (SIL2) is connected, the temperature limiter device is reduced from <b>SIL3 to SIL2!</b> However, the internal 2-channel structure (1oo2D) in the device still remains. Both channels measure the same sensor due to the simplified external wiring.</p>		
	<p><b>4 to 20 mA</b> Here, for example, a transducer for pressure or for another measured value can be connected.</p>		
	<p>4 to 20 mA for both analog inputs</p> <p><b>Attention:</b> When only one probe (SIL2) is connected, the limiter device is reduced from <b>SIL3 to SIL2!</b> However, the internal 2-channel structure (1oo2D) in the device still remains. Both channels measure the same current signal due to the simplified external wiring.</p>		
4	<p><b>Digital input</b> Connection to a potential-free contact</p>		
	<p><b>Analog output:</b> 0 to 20 mA 4 to 20 mA (default setting) 0(2) to 10 V</p> <p><b>Caution:</b> The analog output is <b>not part of the safety function!</b></p>		

Legend	Comment	Screw terminals	Screw terminals
9	<b>Voltage supply</b> Acc. to nameplate	<b>AC:</b> L1 line conductor N neutral conductor 	<b>DC:</b> (L+) (L-) 
10	<b>Alarm relay output (zero-current state)</b> Relay (changeover contact) with fuse cut-out	  <p style="text-align: right;">Internal circuitry</p>	
11	<b>Pre-alarm relay output (KV)</b> Relay (changeover contact)		
	<b>Caution:</b> The pre-alarm relay output is <b>not part of the safety function!</b>		

## 4.4 Checking the wiring of the intrinsically safe electrical circuit



### Attention:

The cover cap that is removed prior to wiring must be put back into place after wiring is complete so that the detent lugs snap back into place!

This is necessary for the proper operation of the probes in the Ex-area!



### Caution:

All screw terminals in the housing must always be tightened to the maximum torque of 0.5 Nm. This also applies to connections that are not required.

- \* Fine-strand lines in ferrules up to max. 1.5 mm<sup>2</sup> or single-strand lines in ferrules up to max. 2.5 mm<sup>2</sup> can be inserted and tightened.
- \* Switch on the device and test whether the measured value of your choice (e.g. temperature or pressure) is displayed without any problems.
- \* Place the cover cap back in its position and make sure it is securely in place.

Limiter/  
Monitor  
Limit value  
43 °C  
43 °C

## 5 Startup of the device

### 5.1 Display and control elements

- \* When the voltage supply is set up, a testing routine starts during which all LEDs flash and the backlight display shows white pixels for 2 s and black pixels for 2 s.

After the testing routine is complete the device shows the main measured value (default setting).

⇒ If an alarm or error message appears, refer to Chapter 16.2 "Alarm messages".

### 5.2 Setting the display after device is switched on

⇒ Chapter 10.6.4 "Normal display"

The main measured value appears on the screen in German (default setting). The example shows a screen layout in which the maximum value of a safety temperature limiter of 70 °C with a pre-alarm of 60 °C is monitored.



If the main measured value for "Power ON" lies within the hysteresis then the pre-alarm and alarm relay outputs are set to inactive.

(1) Switching behavior

(7) Main measured value

(6) Pre-alarm



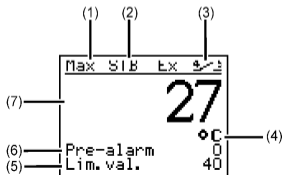

(5) Limit value



(2) Device function

(3) Digital input

(4) Temperature unit



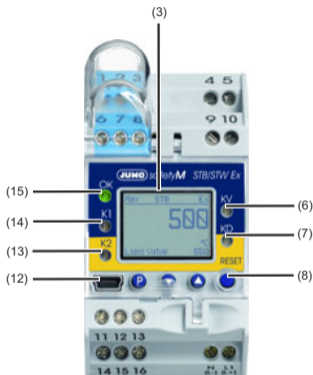

Legend	Comment
3	<b>LCD display</b> Black/white with backlight, 96 x 64 pixels
6	<b>LED KV (yellow)</b> Is lit if the pre-alarm is triggered (pre-alarm relay output active).
7	<b>LED KD (yellow)</b> Is lit if the diagnostic processor has performed a switch-off.
8	<b>Keys</b> (can only be operated when the transparent hood is folded upward) <ul style="list-style-type: none"> <li> Value increase / previous parameter</li> <li> Value reduction / next parameter</li> <li> Programming</li> <li> (RESET)</li> </ul>
12	<b>Setup interface</b>
13	<b>LED K2 (red)</b> Is lit for all errors.
14	<b>LED K1 (red)</b> Is lit for all errors.
15	<b>LED OK</b> Green: valid range, no error Off: error occurred



### 5.3 Selecting and editing parameters (plausibility requirement for input values)

The values are displayed in the normal display.

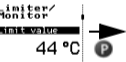
To edit a value – such as the limit value – perform steps 1 to 4



1	Press <b>P</b>		The first menu item "Analog inputs" is highlighted in black. The vertical line to the right shows the current position.
2	Select limiter/monitor with <b>▼</b> Switch to submenu with <b>P</b>		
3	Press <b>▼</b> 2x until limit value appears Press <b>P</b> (limit value flashes)		
4	Set the value of your choice with <b>▼</b> or <b>▲</b> Acknowledge with <b>P</b> (limit value appears twice)		The limit value flashes twice in the display for checking purposes
5	Briefly press <b>P</b> to confirm. The value is adopted and saved.		Back to normal display: With <b>P</b> + <b>▼</b> , "back" menu item, or automatically after timeout
<p> If no key is pressed for 30 seconds (timeout) then the device automatically returns to normal display and the value is not stored. The duration of the timeout can be configured.</p> <p>⇒ See Chapter "Operating overview" on the first inner page of this manual</p>			

## 5.4 Canceling edit

**P** + **↵** are used to cancel editing and the previous value remains.

## 5.5 Acknowledging alarms using the reset key (for temperature limiter STB only)

\* Press and hold **RESET** key

Check marks appear behind the errors.	 <p>ERRORS   RESET Limit value ✓ Channel 1 ✓ Limit value ✓ Channel 2 ✓</p>	The alarm is no longer present and is acknowledged as soon as the bar has run to the end (3 s).
A bell is displayed behind the errors.	 <p>ERRORS   RESET Probe break △ Channel 1 △ Probe break △ Channel 2 △ Diff. value △ Diagnosis △</p>	The alarm condition is still present and cannot be acknowledged.

## 5.6 Acknowledging alarms using the digital input (for temperature limiter STB only)

The digital input can be configured so that it is possible, for example, to unlock alarms via a potential-free contact.

The function only responds to the switching edge from "open" to "closed" state.

In that case the contact has the same behavior as the **RESET** key.

⇒ Chapter 10.4.1 "Function"

## 5.7 Functional test

After the electrical connection in Chapter 4.3 you should proceed with the following steps for your safety:

- \* Set the limit value that the plant must not exceed or drop below.
  - \* When all parameters are in the valid range, press the  (RESET) key until the green OK LED is lit.
  - \* Simulate the limit value being exceeded, initially **without installing the sensors in the potentially explosive area**, and check if the alarm relay output permanently switches off the plant. The K1 and K2 LEDs must light up red even if the measured value is back in the valid range.
  - \* Manually reset the device using RESET until the green OK LED lights up again.
- ⇒ Chapter 5.5 "Acknowledging alarms using the reset key (for temperature limiter STB only)"
- ⇒ Chapter 7.4.2 "Probe arrangement in the Ex-area"

## 5.8 Sealing the device

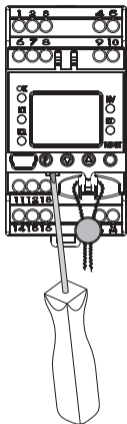

The device settings must not be changed under operating conditions. A lead-sealed see-through cover is therefore placed on top to prevent unintentional or unauthorized adjustment.

Two holes are provided to the left and right of the see-through cover through which wire can be guided for lead sealing to connect the cover to the housing. The wire ends are secured with the seal.

### **Opening the see-through cover for close mounting:**

A screwdriver can be used to pry open the see-through cover.

## 6 Safety Manual

### 6.1 Brief description

The safety temperature limiter (**STB**) and safety temperature monitor (**STW**) enable early and reliable detection and prevention of dangers which could potentially result in personal injuries, environmental damage, or the destruction of production plants and production materials.

Its task is to reliably monitor process variables such as temperature or pressure and to switch the plants to a safe operating status in the event of malfunctions. The measured value at the analog input can be recorded by various probes or standard signals. Even when using double sensors (1oo2) only one physical measuring site is monitored at the measuring point.

Even when using double sensors (1oo2) only **one** physical measuring site is monitored at the measuring point.

If the measured value exceeds the limit value, this is indicated by the installed LEDs K1 and K2 (red) for each channel, and the **safety relevant alarm relay output** (terminal 14 and 16) switches the plant to a safe operating status (**alarm range**).

The SIL 3 requirements of DIN EN 61508 or PL d DIN EN ISO 13849 are met by a device concept that has a 1oo2D structure which ensures reliable detection of errors.

The JUMO safetyM STB/STW Ex is tested according to the ATEX directive 2014/34/EU as associated equipment with an intrinsically safe input.

It meets the requirements of the following identification markings is also certified for use according to DIN EN 50495 and DIN EN ISO 80079-37 as an ignition source monitor as specified in the ATEX directive.

**JUMO GmbH & Co. KG** 36029 Fulda, Germany  
www.jumo.net

**JUMO safetyM STB/STW Ex**

 II (1) G [Ex ia Ga] IIC II (1) D [Ex ia Da] IIIC  
II (1) D [Ex ta Da] IIIC II (2) D [Ex tb Db] IIIC  
II (2) G [Ex eb Gb] IIC II (2) G [Ex db Gb] IIC  
II (1) G [Ex h Ga] IIC II (1) D [Ex h Da] IIIC  
TÜV 11 ATEX 556139 X

 [Ex ia Ga] IIC [Ex ia Da] IIIC  
[Ex h Ga] IIC [Ex h Da] IIIC  
IECEX TUN 15.0036X



Klemmen / Terminals / Borne 1, 2, 3, 6, 7, 8:  
 $U_n = 6,0 \text{ V}$   $C_n = 36,3 \mu\text{F}^*$   
 $I_n = 41,2 \text{ mA}$   $L_n = 20 \text{ mH}^*$   
 $P_n = 61,8 \text{ mW}$  \* : see certificate  
 $0^\circ\text{C} \leq T_a \leq +55^\circ\text{C}$



## 6.2 Safety temperature monitor (STW)

The safety temperature monitor is a device which, when activated, resets automatically if the probe temperature has fallen below or risen above the set limit value by an amount equal to the switching differential. Possible settings: monitoring for limit value overrange or underrange.

Modes of operation:

- Minimum requirements: 2B, 2K, 2P
- Requirements additionally fulfilled: 2N, 2D

### 6.2.1 Safe operating status of STW

The safe status is when the alarm relay output between terminals 14 and 16 is switched off (quiescent current principle).

## 6.3 Safety temperature limiter (STB)

The safety temperature limiter is a device which is permanently locked after activation.

A manual reset using the  (RESET) key is possible once the probe temperature has fallen below/has exceeded the limit value by the amount of the switching differential. Possible settings: monitoring for overrange or underrange.

Modes of operation:

- Minimum requirements: 2B, 2J, 2V, 2K, 2P, and adjustable with special tools
- Requirements additionally fulfilled: 2N, 2F, 2D

### 6.3.1 Safe operating status of STB

The safe status is when the alarm relay output between terminals 14 and 16 is switched off (quiescent current principle).

This status is maintained until manual unlocking in the valid range of the JUMO safetyM STB/STW Ex.

The transparent, sealable protective cover prevents unauthorized operation.

The  (RESET) key can be accessed for manual unlocking with the aid of a tool.

## 6.4 Relevant standards

Failure of the devices could affect the safety of persons and/or the safety of the environment.

Certification according to DIN EN 61508 is provided because of the worldwide use of these systems.

The JUMO safetyM STB/STW Ex temperature monitoring unit with the extra code "059" meets the requirements

- For the safety function up to SIL 3 according to DIN EN 61508 Part 1 to 7:  
Functional safety of electrical/electronic/programmable electronic safety-related systems
- DIN EN 61511 Part 1 to 3:  
Functional safety - Safety instrumented systems for the process industry sector
- DIN EN 14597  
Temperature control devices and temperature limiters for heat generating systems
- DIN EN 60730-2-9:  
Automatic electrical controls for household and similar use - Part 2-9: Particular requirements for temperature sensing controls
- EN 61326
- DIN EN ISO 13849-1 PL<sub>e</sub>

## 6.5 Validity of the safety manual



The evaluation described in this Safety Manual in terms of functional safety and display of certificates applies to the specified versions of temperature monitoring units including probe versions.

Specifications that do not take the sensor technology into consideration are identified as such.

## 6.6 Sensor connection possibilities (SIL)

The JUMO safetyM STB/STW Ex evaluation unit is always structured in the same way. Various possibilities are available for sensor connection. These possibilities are listed in the following table along with the achievable SIL level:

Variant	Connected sensors	Architecture		Achievable SIL			
		Sensor technology	Logic				
1	1x Pt100 in two-wire circuit Single sensor	1oo1	1oo2D	2			
1a	2x Pt100/1000 two-wire circuit	1oo2	1oo2D	3			
2	2x Pt100/1000 three-wire circuit	1oo2	1oo2D	3			
3	2x thermocouple	1oo2	1oo2D	3			
4	1x Pt100/1000 Two-wire and three-wire circuit 1x thermocouple	1oo2	1oo2D	3			
5	STB/STW 70.1155 without sensor technology 1oo2D architecture:  No probe or use of 4 to 20 mA (means that the sensor is not taken into account for the calculation).	Sensors connected by the plant operator: architecture 1oo1 or 1oo2 according to connection	1oo2D	SIL (architecture) of the sensor used (HW only)	Systematic suitability (SC) of the sensor used	Max. achievable SIL of the system with 1oo1 sensor technology architecture	Max. achievable SIL of the system with 1oo2 sensor technology architecture
				1	1	1	1
				1	2	1	2
				2	2	2	2
				2	3	2	3
				3	3	3	3

**Note:**

Variants 1 to 4 were evaluated with JUMO probes according to data sheets 901006 and 902006. For variant 5 no sensor technology was included (only the JUMO safetyM STB/STW Ex). In this case, the plant operator selects the sensor technology. For this reason, the plant operator is responsible for evaluating the achieved SIL.

If the used SIL-capable sensor consists of hardware and software (e.g. transmitter), the maximum SIL that can be achieved – irrespective of the architecture – is the one according to which the sensor software was developed (so, for example, if the sensor software has SIL 2, the max. achievable SIL is 2).

The possibility to connect passive sensors such as double thermocouples or Pt100/1000 sensors means that the sensors do not necessarily require a SIL qualification. In this case, the specification of the failure rates for the passive sensors is sufficient for the SIL qualification of the overall system. The plant operator must always determine the  $PFD_{avg}$  and/or PFH value of the overall safety chain to determine the achieved SIL.

The requirements regarding proof-check interval and lifetime apply only in terms of functional safety.

The requirements as specified by DIN EN 14597 are defined in this operating manual 70115500T90Z001K000 and are independent of the requirements of this safety manual.

**Temperature probe**

The admissible measuring ranges must be observed for devices with approval according to DIN EN 14597 and SIL certification. If other temperature probes than those described by JUMO data sheets 901006 and 902006 are used, their recording and suitability for use must be verified.

**Isolated thermo points on double thermocouples**

For safety reasons, when connecting double thermocouples the measuring circuits must be isolated. That means that the thermo-wires have no connection to the protection fitting, and in the case of double thermocouples also that there is no electrical connection between the two measuring circuits (isolated assembly).

## 6.7 Standards and definitions

**Table 1: Terms and abbreviations according to DIN EN 14597**

Abbreviation	Explanation
Type 2	Mode of operation for which the manufacturing variation and migration of the operating value, operating duration, or operating procedure has been checked.
Type B	Micro disconnection in operation, corresponding contact disconnection at at least one pole to provide functional reliability.
Type D	A free trip mechanism that also cannot be closed temporarily for as long as the error persists.
Type F (STB)	A mode of operation in which, after the RS has been installed, it can only be reset with the aid of a tool.
Type J (STB)	A free trip mechanism with contacts that cannot be prevented from opening and which may not function as an automatically resetting RS if the means of resetting is held in the "Reset" or "On" position.
Type K	A probe mode of operation in which a probe break or a disconnection between the probe head and the switching head does not cause the operating value to increase.
Type N	A mode of operation in which the operating value does not increase as a result of a leak in the probe or in the parts that connect the probe and switching head. This mode is intended for use with electrical error models.
Type V (STB)	A lockout that can only be reactivated through a manual reset.
Type P	A mode of operation that is effective following a specified test through a change in temperature, as specified in 17.101 of DIN EN 60730-2-9.

**Table 2: Terms and abbreviations according to DIN EN 61508 and DIN EN 61511**

Name	Description
Actuator	Part of a safety-related system that intervenes in the process to achieve a safe state.
EUC	EUC (equipment under control) Equipment, machine, apparatus, or system used for manufacturing, shaping materials, for transport, medical purposes, or other activities.
E/E/PE	Electrical/electronic/programmable electronic (E/E/PE): based on electrical (E) and/or electronic (E) and/or programmable electronic (PE) technology
Failure	End of the ability of a functional unit to perform a required function.
Diagnostic coverage	Partial reduction in the probability of critical hardware failures due to the use of automatic diagnostic tests.
Error	A non-normal condition that can cause a reduction or the loss of the ability of a functional unit to perform a required function.
Functional safety	A part of overall safety related to the EUC and EUC control system that depends on the correct function of the E/E/PE safety-relevant system, safety-relevant systems of other technology, and external equipment for risk reduction.
Functional unit	Unit consisting of hardware or software or both that is suitable for performing a specified task.
Dangerous failure	A failure with the potential of placing the safety-related system in a dangerous state or a state without functional capability.
Safe failure	A failure without the potential of placing the safety-related system in a dangerous state or state without functional capability.
Hazard	Potential source of damage
Safety	Absence of unjustifiable risks

**Table 2: Terms and abbreviations according to DIN EN 61508 and DIN EN 61511**

Name	Description
Safety function	A function that is performed by an E/E/PE safety-related system, safety-related system based on other technology, or external equipment for reducing risk with the goal of achieving or maintaining a safe state for the EUC taking into consideration a specified dangerous event
Safety integrity	The probability that a safety-related system will perform the required safety function under all specified conditions within a specified period of time according to requirements.
Safety Integrity Level (SIL)	One of four discrete levels for specifying the requirement for safety integrity of the safety functions assigned to the E/E/PE safety-related system. Safety integrity level 4 represents the highest level of safety integrity, while safety integrity level 1 represents the lowest.
Safety-related system	A system that <ul style="list-style-type: none"> <li>- performs necessary safety functions that are required to reach or maintain a safe state for the EUC and</li> <li>- is designed by itself or with other E / E / PE safety-related systems, safety-related systems of other technology, or external equipment for risk reduction to achieve the necessary safety integrity for the required safety functions.</li> </ul>
Safety instrumented system (SIS)	Safety instrumented system to perform one or more safety-related functions. A SIS consists of sensor(s), logic system, and actuator(s).
Lambda: $\lambda$	Failure rate per hour
Lambda <b>D</b> angerous: $\lambda_D$	Rate of dangerous failures per hour
Lambda <b>D</b> angerous <b>D</b> etect: $\lambda_{DD}$	Rate of detected dangerous failures per hour
Lambda <b>D</b> angerous <b>U</b> ndetect: $\lambda_{DU}$	Rate of undetected dangerous failures per hour
Lambda: $\lambda_S$	Rate of safe failures per hour

**Table 2: Terms and abbreviations according to DIN EN 61508 and DIN EN 61511**

<b>Name</b>	<b>Description</b>
Lambda: $\lambda_{SD}$	Rate of detected safe failures per hour
Lambda: $\lambda_{SU}$	Rate of undetected safe failures per hour
BPCS	Basic process control system
DC	<b>D</b> iagnostics <b>C</b> overage
FIT	Failures In Time ( $1 \times 10^{-9}$ per h)
HFT	<b>H</b> ardware <b>F</b> ault <b>T</b> olerance
PFD	Probability of Failure on Demand
PFD <sub>avg</sub>	Average Probability of Failure on Demand
MooN	Architecture with M from N channels
MTBF	Mean Time Between Failures
MTTR	Mean Time To Repair
MRT	Mean Repair Time
SFF	<b>S</b> afe <b>F</b> ailure <b>F</b> raction
SIL	Safety Integrity Level

## 6.8 Safety instrumented parameters related to the temperature monitoring unit

The following parameters were calculated by means of a component FMEDA under the following conditions:

- Error models corresponding to requirements of DIN EN 61508 for conformity with SIL2 or SIL3
- Failure rate of components according to the RDF 2000 UTE C 80-810 standard and SN 29500
- Sensor technology was combined as a subsystem in the following 6 variants:

### 6.8.1 Failure rates and SFF for type 701155/X-XX-025X-XXXX-23... (AC 230 V)

**Table 3:**

Variant	$\lambda_s$ [FIT]	$\lambda_{dd}$ [FIT]	$\lambda_{du}$ [FIT]	SFF	PFH (1/h)	PDF <sub>avg</sub>
1	985.14	306.75	32.93	96 %	$5.18 \text{ e}^{-9}$	$2.29 \text{ e}^{-4}$
1a	985.14	306.75	32.93	96 %	$1.66 \text{ e}^{-9}$	$7.29 \text{ e}^{-5}$
2	988.1	303.79	32.93	96 %	$1.66 \text{ e}^{-9}$	$7.29 \text{ e}^{-5}$
3	1001.55	324.85	36.68	96 %	$1.71 \text{ e}^{-9}$	$7.46 \text{ e}^{-5}$
4	1007.61	341.89	38.58	96 %	$1.73 \text{ e}^{-9}$	$7.55 \text{ e}^{-5}$
5	1000.95	318.38	31.75	96 %	$1.54 \text{ e}^{-9}$	$6.74 \text{ e}^{-5}$

**Note:**

Variants 1 to 4 were evaluated with JUMO probes according to data sheets 901006 and 902006.

For variant 5 no sensor technology was included (only the JUMO safetyM STB/STW Ex).

In this case, the plant operator selects the sensor technology.

This can be a transducer for pressure or for another measured variable, for example, which is fed in via the 4 to 20 mA current input.

## 6.8.2 Failure rates and SFF for type 701155/X-XX-025X-XXXX-25 (AC/DC 24 V)

Table 4:

Variant	$\lambda_s$ [FIT]	$\lambda_{dd}$ [FIT]	$\lambda_{du}$ [FIT]	SFF	PFH (1/h)	PFD <sub>avg</sub>
1	919.23	306.82	34.24	96 %	$7.22 \cdot 10^{-9}$	$3.19 \cdot 10^{-4}$
1a	919.23	306.82	34.24	96 %	$3.71 \cdot 10^{-9}$	$1.63 \cdot 10^{-4}$
2	886.19	303.86	34.24	96 %	$3.71 \cdot 10^{-9}$	$1.63 \cdot 10^{-4}$
3	947.18	325.86	37.89	96 %	$3.75 \cdot 10^{-9}$	$1.64 \cdot 10^{-4}$
4	953.24	350.21	40.59	96 %	$3.85 \cdot 10^{-9}$	$1.69 \cdot 10^{-4}$
5	938.89	323.57	36.89	96 %	$3.68 \cdot 10^{-9}$	$1.61 \cdot 10^{-4}$

### Note:

Variants 1 to 4 were evaluated with JUMO probes according to data sheets 901006 and 902006.

For variant 5 no sensor technology was included (only the JUMO safetyM STB/STW Ex).

In this case, the plant operator selects the sensor technology.

This can be a transducer for pressure or for another measured variable, for example, which is fed in via the 4 to 20 mA current input.

The PFH and PFD<sub>avg</sub> values were calculated with the assumption that the time to restore the system is 8 h (MTTR = 72 h). Furthermore, the calculation was based on a lifetime of 10 years ( $T_1 = 10 \text{ y}$ ). The Common Cause Factor was determined according to the tables of DIN EN 61508 for sensor technology and logic.

## 6.9 Determining the safety integrity level (SIL)

The achievable safety integrity level is determined by the following safety-related parameters:

- Average probability of dangerous failures of a safety function on demand ( $PFD_{avg}$ ),
- Hardware fault tolerance (HFT) and
- Safe failure fraction (SFF).

The specific safety-related parameters for the measuring system of the JUMO safetyM STB/STW Ex can be found in the table in the "Safety-related parameters" chapter.

The following table shows how the "safety integrity level" (SIL) depends on the "average probability of dangerous failures of a safety function of the entire safety-related system" ( $PFD_{avg}$ ) according to DIN EN 61508. The "low demand mode" is considered here, i.e. the demand rate for the safety-related system averages once a year.

Table: High Demand Table for PFH

**Table 5: High Demand Table for PFH**

Safety Integrity Level (SIL)	Operating mode with high demand rate PFH (high demand mode)
4	$\geq 10^{-9}$ to $< 10^{-8}$
3	$\geq 10^{-8}$ to $< 10^{-7}$
2	$\geq 10^{-7}$ to $< 10^{-6}$
1	$\geq 10^{-6}$ to $< 10^{-5}$

**Table 6: Low Demand Table PFD**

Safety Integrity Level (SIL)	Operating mode with low demand rate $PFD_{avg}$ (low demand mode)
4	$\geq 10^{-5}$ to $< 10^{-4}$
3	$\geq 10^{-4}$ to $< 10^{-3}$
2	$\geq 10^{-3}$ to $< 10^{-2}$
1	$\geq 10^{-2}$ to $< 10^{-1}$

The sensor, logic unit, and actuator together form a safety-related system that performs a safety function. The "average probability of dangerous failures of the entire safety-related system" ( $PFD_{avg}$ ) is usually divided up into the sensor, logic unit, and actuator subsystems according to the following diagram.

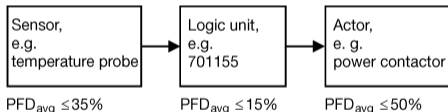
**Figure 1:**

Typical subdivision of the "average probability of dangerous failures of a safety function on demand" ( $PFD_{avg}$ ) into subsystems

The specifications related to functional safety in this safety manual include sensor technology (resistance temperature probe, thermocouples), logic unit (701155) and, as a signal contact, the relay output in the JUMO safetyM STB/STW Ex system.

The actuator (for example a power contactor) is plant-related and must be taken into consideration separately according to the standard for the safety loop.

### 6.9.1 Safety integrity of the hardware

According to DIN EN 61508, a distinction must be made between systems of type A and systems of type B.

A subsystem can be considered to be type A if, for the components required to achieve the safety function,

- the failure behavior of all components used is sufficiently defined; and
- the behavior of the subsystem can be fully determined under error conditions; and
- reliable failure data from experience in the field exists for the subsystem to show that the assumed failure rates for detected and undetected dangerous failures are achieved.

A subsystem can be considered to be type B if, for the components required to achieve the safety function,

- the failure behavior of at least one of the components used is not sufficiently defined, or
- the behavior of the subsystem cannot be fully determined under error conditions, or
- no sufficiently reliable failure data from experience in the field exists for the subsystem to support the utilized failure rates for detected and undetected dangerous failures.

The JUMO safetyM STB/STW Ex corresponds to a type B system.

The following table shows the achievable safety integrity level (SIL) depending on the safe failure fraction (SFF) and the hardware fault tolerance (HFT) for safety-related type B subsystems.

**Table 7: For the JUMO safetyM STB/STW Ex**

Safe failure fraction (SFF)	Hardware fault tolerance (HFT) for type B		
	0	1	2
<60 %	Not allowed	SIL 1	SIL 2
60 to <90 %	SIL 1	SIL 2	SIL 3
90 to <99 %	SIL 2	SIL 3	SIL 4
≥99 %	SIL 3	SIL 4	SIL 4

## 6.9.2 Safety-relevant system properties

Device versions differ in the following architectures:

The evaluation unit from the JUMO safetyM STB/STW Ex in the STW and STB versions is implemented as 1oo2D architecture.

**Figure 2: The types with a single sensor are executed using one-channel sensor technology (1oo1)**

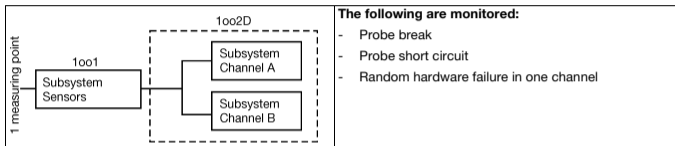

**Figure 3: The variants with two sensors are consistently structured with two channels.**

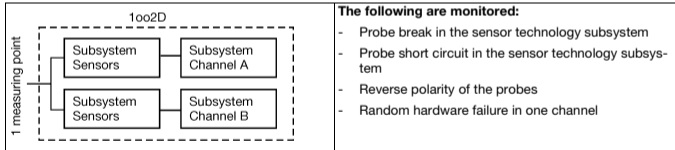

The systems have a lifetime of ten years.

The proof check for SIL 2 and SIL 3 certified systems is also ten years.

If the temperature is above/below the admissible limits, the system must switch to the safe state without delay. Premature switching is admissible if a malfunction is detected.

Table 8:

Safety feature	Requirement / comment	
SIL The sensor technology is included in the SIL evaluation	SIL2	SIL3
Operating mode concerning safety function	Operating mode with low and high demand rate possible on a customer-specific basis	
Safety-critical inputs	Temperature sensor inputs 4 to 20 mA current loop	
Safety-relevant inputs	Setup and parameterization	
Safety-critical output	Alarm contact limit value	
Subsystem type	Type B	
Safety architecture (JUMO safetyM STB/STW Ex logic unit)	1oo2D	
Safety architecture (sensor technology)	SIL2 1oo1	SIL3 1oo2
Hardware fault tolerance (JUMO safetyM STB/STW Ex logic unit)	HFT=1	
Hardware fault tolerance (sensor technology)	SIL2: HFT=0	SIL3: HFT=1
Safe failure fraction	SIL2 sensor technology HFT=0: 90 % to <99 %	SIL3 sensor technology HFT=1: 90 % to <99 %
CCF	Calculation according to DIN EN 61508 Part 7 Appendix D and/or DIN EN ISO 13849-1 Table F.1 min. 65 %	

**Table 8:**

Safety feature	Requirement / comment	
Average failure probability of a safety function on demand (overall system)	SIL 2: Low demand: $PFD_{avg} < 10^{-2}$ High demand: $PFH < 10^{-6}$	SIL3: Low demand: $PFD_{avg} < 10^{-3}$ High demand: $PFH < 10^{-7}$
Interval for repeat test	No repeat test	
Planned operating duration	10 years	
Architecture according to DIN EN ISO 13849-1	Sensor technology, one-channel: cat. 2	Sensor technology, two-channel: cat. 3
$MTTF_{d-DC_{avg}}$ according to DIN EN ISO 13849-1 table K.1	PL d: $\geq 62$ years $DC_{avg} \geq 60\%$	PL e: $\geq 62$ years $DC_{avg} \geq 90\%$
Modes of operation and software class according to DIN EN 14597	The JUMO safetyM STB/STW Ex possesses the following modes of operation: 2B, 2D, 2F, 2K, 2J, 2V, 2N, 2P software class C	

## 6.10 Determining the achieved performance level PL

The following safety-related parameters are required to determine the Performance Level of components/devices:

As further parameters to be observed, operational aspects such as the demand rate and/or the test rate of the safety function can also influence the resulting PL.

Excerpt from DIN EN ISO 13849-1



This excerpt contains references to the complete DIN EN ISO 13849-1 body of standards, which are therefore not reproduced in this chapter.

Table 9: Terms and abbreviations according to DIN EN ISO 13849

Formula symbol or abbreviation	Description	Definition or location
PL (a, b, c, d, e)	Designation for the Performance Level	Table 3
AOPD	Active Opto-Electronic Protective Device (e.g. light barrier)	Annex H
B, 1, 2, 3, 4	Designation for the categories	Table 7
B <sub>10d</sub>	Number of cycles in which a dangerous failure occurred in 10 % of a random sample of the observed pneumatic or electromechanical components that are subject to wear (mean time to dangerous failure)	Annex C
Cat.	Category	3.1.2
CC	Current Converter	Annex I
CCF	<b>Common Cause Failure</b>	3.1.6
DC	<b>Diagnostic Coverage</b>	3.1.26
DC <sub>avg</sub>	Average diagnostic coverage	E.2
F, F1, F2	Frequency and/or duration of the exposure to danger	A.2.2
FB	Function block	4.6.3
FVL	Programming language with unlimited language range	3.1.35
FMEA	Failure Modes and Effects Analysis	7.2
I, I1, I2	Input device, e.g. sensor	6.2
i, j	Index for counting	Appendix D
I/O	Inputs/outputs	Table E.1
ī <sub>ab</sub> , ī <sub>bc</sub>	Fasteners	Image 4

**Table 9: Terms and abbreviations according to DIN EN ISO 13849**

Formula symbol or abbreviation	Description	Definition or location
K1A, K1B	Contactors	Annex I
L, L1, L2	Logic	6.2
LVL	Programming language with limited language range	3.1.34
M	Motor	Annex I
MTTF	Mean Time To Failure	Annex C
MTTF <sub>c</sub>	Mean Time to Critical Failure	3.1.25
MTTF <sub>d</sub>	Mean Time to Dangerous Failure	
$n, N, \bar{N}$	Number of units	6.3, D.1
$N_{low}$	Number of SRP/CS with PL <sub>low</sub> in an SRP/CS combination	6.3
O, O1, O2, OTE	Output device, e.g. drive unit	6.2
P, P1, P2	Possibility of avoiding the danger	A.2.3
PES	Programmable Electronic System	3.1.22
PL	Performance Level	3.1.23
PLC	Programmable Logic Controller	Annex I
PL <sub>low</sub>	Lowest performance level of an SRP/CS in an SRP/CS combination	6.3
PL <sub>f</sub>	Required Performance Level	3.1.24
$r_a$	Demand rate	3.1.30
RS	Rotary encoder	Annex I
S, S1, S2	Severity of violation	A.2.1

**Table 9: Terms and abbreviations according to DIN EN ISO 13849**

Formula symbol or abbreviation	Description	Definition or location
SW1A, SW1B, SW1	Position switch	Annex I
SIL	Safety Integrity Level	Table 4
SK (cat.)	Category (B, 1, 2, 3, 4), structure as basis to achieve a certain PL	
SRASW	Safety-Related Application Software	4.6.3
SRESW	Safety-Related Embedded Software	4.6.2
SRP	Safety-Related Part	General
SRP/CS	<b>S</b> afety- <b>R</b> elated <b>P</b> art of (a) <b>C</b> ontrol <b>S</b> ystem(s)	3.1.1
Sub-PL/Sub-SIL	PL or SIL at subsystem level. A subsystem is a system that – based on a subtask – already adequately performs a safety function (for example, an input module that reliably records the inputs).	
TE	Test facilities	6.2
$\bar{T}_M$	Functional life	3.1.28
$T_M$	<b>M</b> ission <b>T</b> ime (functional life, designated period of utilization)	
$T_{10d}$ value	Reference value for a preventative replacement (10 % of the B10d value). At this value, a dangerous failure has already occurred for approx. 63 % of all components. In this case, the standard DIN EN ISO 13849-1:2006 recommends replacement.	

### 6.11 Sensor connection possibilities (PL)

The JUMO safetyM STB/STW Ex evaluation unit is always structured in the same way. Various possibilities are available for sensor connection. These possibilities are listed in the following table along with the achievable PL level:

**Table 10: Achievable PL**

Variant	Connected sensors	Sensor technology architecture	Logic architecture	Achievable PL		
1	1x Pt100 two-wire circuit	1oo1	1oo2D	PLd		
1a	2x Pt100/1000 two-wire circuit	1oo2	1oo2D	PLe		
2	2x Pt100/1000 three-wire circuit	1oo2	1oo2D	PLe		
3	2x thermocouple	1oo2	1oo2D	PLe		
4	1x Pt100/1000 two-wire and three-wire circuit 1x thermocouple	1oo2	1oo2D	PLe		
5	STB/STW 701155 without sensor technology 1oo2D architecture No probe or use of 4 to 20 mA (means that the sensor is not taken into account for the calculation).	Sensors connected by the plant operator; architecture 1oo1 or 1oo2 according to connection	1oo2D	PL of the sensor used $MTTF_d = 100$ years	Max. achievable PL of the system with 1oo1 sensor technology architecture $DC_{701155} \geq 90\%$	Max. achievable PL of the system with 1oo2 sensor technology architecture $DC_{701155} \geq 90\%$
				PLb	PLd	PLe
				PLc	PLd	PLe
				PLd	PLd	PLe
				PLe	PLe	PLe

**Note:**

Variants 1 to 4 were evaluated with JUMO probes according to data sheets 901006 and 902006. For variant 5 no sensor technology was included (only the JUMO safetyM STB/STW Ex). In this case, the plant operator selects the sensor technology. For this reason, the plant operator is responsible for evaluating the achieved PL.

### 6.11.1 Calculations DIN EN ISO 13849-1 Performance Level – low voltage 230 V

Table 11:

Variant	MTTF <sub>d</sub>	DC <sub>avg</sub>	CCF	PL
1	100 years <sup>3</sup> (336 years)	90 %	80	PLd
1a	100 years <sup>3</sup> (336 years)	90 %	80	PLe
2	100 years <sup>3</sup> (339 years)	90 %	80	PLe
3	100 years <sup>3</sup> (316 years)	90 %	80	PLe
4	100 years <sup>3</sup> (312 years)	90 %	80	PLe
5	100 years <sup>3</sup> (326 years)	91 %	80	See above table

### 6.11.2 Calculations DIN EN ISO 13849-1 Performance Level – extra low voltage (ELV) 24 V

Table 12:

Variant	MTTF <sub>d</sub>	DC <sub>avg</sub>	CCF	PL
1	100 years <sup>3</sup> (335 years)	90 %	80	PLd
1a	100 years <sup>3</sup> (335 years)	90 %	80	PLe
2	100 years <sup>3</sup> (338 years)	90 %	80	PLe
3	100 years <sup>3</sup> (314 years)	90 %	80	PLe
4	100 years <sup>3</sup> (304 years)	90 %	80	PLe
5	100 years <sup>3</sup> (317 years)	90 %	80	See above table

3. The MTTF<sub>d</sub> value of a subsystem must be limited to 100 years according to the DIN EN ISO 13849-1 requirements.

### 6.11.3 Contribution to risk reduction by the control system

The objective of compliance with the overall design process for the machine is to achieve the safety objectives (see 4.1 in DIN EN 13849-1). The design of the SRP/CS to provide the required risk reduction is an integral part of the overall design process for the machine. The SRP/CS provides the safety function(s) with a PL that achieves the required risk reduction. Through the provision of safety functions, either as an inherently safe part of the construction or as the control of a protective guard or protective device, the design of the SRP/CS is part of the risk reduction strategy. This is an iterative process and is depicted in images 1 and 3 in DIN EN 13849-1.

The features of each safety function (see section 5 in DIN EN 13849-1) and the required Performance Level must be described and documented in the specification of the safety requirements.

In this part of DIN EN ISO 13849, the Performance Levels are defined in the form of the probability of a dangerous failure per hour. Five Performance Levels (a to e) are specified with defined ranges for the probability of a dangerous failure per hour (see table).

**Table 13:**

Performance Level (PL)	Average probability of a dangerous failure per hour 1/h
a	$\geq 10^{-5}$ to $< 10^{-4}$
b	$\geq 3 \times 10^{-6}$ to $< 10^{-5}$
c	$\geq 10^{-6}$ to $< 3 \times 10^{-6}$
d	$\geq 10^{-7}$ to $< 10^{-6}$
e	$\geq 10^{-8}$ to $< 10^{-7}$

NOTE: in addition to the average probability of a dangerous failure per hour, further measures are required to achieve the PL.

Schematic representation of a combination of safety related parts of control systems for processing a typical safety function

Figure 4:

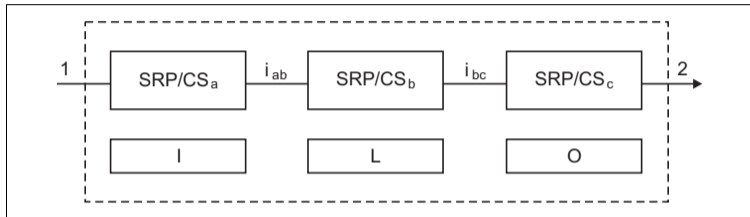

I Input

L Logic

O Output

1 Start event, e.g. manual actuation of a key, opening of a protective guard, interruption of the beam of an AOPD

2 Drive unit of the machine, e.g. motor brake

## 6.12 Performance Level

For application in this part of DIN EN ISO 13849, the capability of safety-related parts to perform a safety function is expressed through the determination of a Performance Level.

The PL must be assessed for each selected SRP/CS and/or SRP/CS combination that performs a safety function. The PL of the SRP/CS must be determined by assessing the following aspects:

- The  $MTTF_c$  value of individual components (see Appendices C and D)
- The DC (see Appendix E)
- The CCF (see Appendix F)
- The structure (see section 6)
- The behavior of the safety function under failure conditions (see section 6)
- Safety-related software (see 4.6 and Appendix J)
- Systematic failures (see Appendix G)
- The capability to perform a safety function under predictable environmental influences

## 6.13 Correlation between the Performance Level (PL) and Safety Integrity Level (SIL)

PL	SIL (IEC 61508-1, for information) – high/continuous operating mode
a	No equivalent
b	1
c	1
d	2
e	3

The following table depicts the procedure for selecting the categories in combination with  $MTTF_d$  for each channel and the  $DC_{avg}$ , in order to achieve the required PL for each safety function.

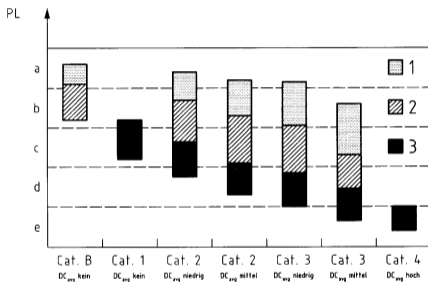
Table 14: Relationship between the categories  $DC_{avg}$ ,  $MTTF_d$  of each channel, and PL

PL Performance Level

1  $MTTF_d$  of each channel = low

2  $MTTF_d$  of each channel = medium

3  $MTTF_d$  of each channel = high

The figure above shows the different possible combinations for assessing the category with  $DC_{avg}$  (horizontal axis) and the  $MTTF_d$  of each channel (bars). The bars in the diagram show the three  $MTTF_d$  areas of each channel (low, medium and high) that can be selected to achieve the required PL.

Before the simplified procedure from the diagram shown is applied (which shows the results of different Markov models on the basis of intended architectures from section 6), the category of the SRP/CS and the  $DC_{avg}$  and the  $MTTF_d$  of each channel must have been determined (see section 6 and Appendices C to E).

For categories 2, 3, and 4, sufficient measures against failures due to combined failures must be fulfilled (see Appendix F). Taking these parameters into account, the figure presents a graphical procedure for determining the PL achieved by the SRP/CS. The combination of category (including failures due to combined failures) and  $DC_{avg}$  determines which column must be selected in image 5. In accordance with the  $MTTF_d$  of each channel, one of the three differently hatched areas of the applicable column must be selected.

The vertical position of these areas determines the achieved PL, which can be read off the vertical axis. If the area covers two or three possible PLs, the achieved PL is specified in table 7. To select the exact PL on the basis of the precise value of the  $MTTF_d$  of each channel, see Appendix K.

## 6.14 Other applicable device documentation

For the JUMO safetyM STB/STW Ex, the measures, values, and requirements specified in this operating manual regarding mounting, electrical connection, function, and startup must be observed.

## 6.15 Behavior during operation and in case of malfunction

Behavior during operation and in case of malfunction is described in the operating manual.

A functional test must be performed after startup, repair in the safety system, or a change in safety-related parameters. If an error is detected during a functional test, measures must be taken to once again ensure the functional capability of the safety system. This, for example, can be done by replacing the logic unit. Appropriate documentation of the tests performed is recommended.

## 6.16 Regular tests

No test is required for SIL 2 and SIL 3 certified systems since the proof check equals the lifetime. Each is ten years.



After the lifetime expires, the systems no longer meet the requirements according to their SIL certification.

### 6.16.1 Recommended tests for temperature probes

To ensure safe and reliable operation of the thermometers, the following service and maintenance work must be performed (also during commissioning):

The following tests are recommended at certain intervals:

- As indicated in the table below, the insulation resistance of the measuring circuit must be measured against the protection fitting (for thermocouples: only for the insulated measuring circuit; in the case of multiple measuring circuits, the insulation test must also be performed between the individual measuring circuits). The minimal insulation resistance at room temperature should be 100 M $\Omega$  at DC 100 V.
- Damage and corrosion and Signs of wear of thermometers – protection tubes
- Clear assignment of sensor and associated protection tube/immersion sleeve by checking the installation depth
- Corrosion and correct positioning of the contacts and terminals of cable connections
- Seals of terminal heads and cable entries
- Interruptions due to "knocking, shaking" on the thermometer/measuring insert

Since the maximum operating temperature influences the drift behavior, the thermometer should be recalibrated or replaced at certain intervals to ensure reliable and precise temperature measurement.

The testing intervals are listed in the table below:

**Table 15: Testing intervals**

Maximum operating temperature	Pt – RTD temperature probe	Thermocouples
200 °C	5 years	5 years
550 °C	2 years	5 years
700 °C	1 year	2 years
1000 °C		Non-precious metal: 1 year; precious metal: 2 years
1500 °C		1 year



The testing intervals specified here are recommendations that must be adapted to the particular conditions at the operating location and, if necessary, the user should perform the tests more regularly.

## 7 ATEX ignition protection type "i"

### 7.1 Intended use

The JUMO safetyM STB/STW Ex is a safety device designed according to Directive 2014/34/EU, chapter 1(1)(b) for measuring temperatures directly using resistance probes or thermocouple probes, or other physical measurands such as pressure, with the aid of a suitable transmitter and the use of a 4-20 mA current input.

The stipulations and requirements for use specified in this document must be taken into consideration. All specifications below with regard to probes or sensor technology relate to the probes listed in Chapter 11.11 to Chapter 11.14. If other probes are used, their suitability must first be tested.



#### **Important information:**

Thermocouples should be evaluated with at least the requirements of EN 60584 or DIN 43710. RTD temperature probes should be evaluated with at least the requirements of EN 60751. Parameter values such as response rate, temperature stability, age drift, self-heating behavior, failure rates, fault models, etc. should likewise be taken into account.

The JUMO safetyM STB/STW Ex is associated apparatus that may only be used outside the Ex-zone. Another use or one that goes beyond the specified use - with respect to use in potentially explosive areas - is considered as not being in accordance with the intended use.

Liability for resulting damages cannot be assumed.

The JUMO safetyM STB/STW Ex is built according to the relevant standards and directives as well as to the applicable safety regulations. Nevertheless, improper use may lead to personal injury or material damage.

To avoid danger, the JUMO safetyM STB/STW Ex may only be used:

- For the intended use
- When in good order and condition
- Under consideration of this operating manual

**DANGER!**

The Ex approval becomes null and void in the event of incorrect use of the JUMO safetyM STB/STW Ex or non-compliance with the safety requirements of this operating manual.

**7.1.1 Installation regulations**

If electrical apparatus is used in plants and ambient conditions with the "intrinsic safety" ignition protection type, the obligations of the applicable installation regulations according to EN 60079-14 "Explosive atmospheres – Part 14: Electrical installations design, selection and erection" are to be considered along with other applicable requirements.

## 7.2 Identification marking according to ATEX directive 2014/34/EU and EN standards EN 60079-11 "i", EN 50495, and EN ISO 80079-37 "h":



II (1) G [Ex ia Ga] IIC	<b>according to EN 60079-0; -11; -26</b>
II (1) D [Ex ia Da] IIIC	



II (1) G [Ex ia Ga] IIC  
II (1) D [Ex ia Da] IIIC

Standard designation according to EN 60079-0  
Explosion group II C gases, low ignition energy such as hydrogen  
III C conductive dusts

Equipment Protection Level:  
Ga (gases) for category 1, zone 0 for gas  
Da (dust) for category 1, zone 20 for dust

Designation according to standard series EN 60079 for electrical devices  
ia: related equipment according to ignition protection „j“  
intrinsically safe according to EN 60079-11  
„ia“ (2-failsafe) for category 1

### Standard designation

Category according to ATEX directive 2014/34/EU  
G: gas explosion protection; D: dust explosion protection

Related equipment for intrinsic safety according to EN 60079-11 for category 1  
Applications for ignition protection type intrinsic safety „ia“

Guidelines designation for device group II (non-firedamp endangered mine workings)

Designation explosionproof according to ATEX directive 2014/34/EU



II (2) G [Ex eb Gb] IIC	<b>according to EN 50495 and EN 60079-7</b>
II (1) D [Ex ta Da] IIIC	<b>according to EN 50495 and EN 60079-31</b>
II (2) D [Ex tb Db] IIIC	



II (2) G [Ex eb Gb] IIC  
II (1) D [Ex ta Da] IIIC  
II (2) D [Ex tb Db] IIIC

Standard designation according to EN 60079-0

Explosion group II C gases, low ignition energy such as hydrogen  
III C conductive dusts

Equipment Protection Level:

Gb: for use in zone 1 or 2 for gases

Da: for use in zone 20, 21 or 22 for dust

Db: for use in zone 21 or 22 for dust

Standard series designation according to EN 50495 <sup>1)</sup>

"eb" increased safety for category 2, b: zone 1 or 2 for gas

"ta" protection with housing for category 1, a: zone 20, 21 or 22 for dust

"tb" protection with housing for category 2, b: zone 21 or 22 for dust

Standard series designation according to EN 60079 for electrical devices

ignition protection "e" increased safety according to EN 60079-7

ignition protection "t" dust explosion protect. with housing accord. to EN 60079-31

#### Standard designation

Category according to ATEX directive 2014/34/EU

G: explosive atmosphere consisting of gas, vapor or mist

D: explosive atmosphere consisting of dust

Safety devices according to EN 50495

- for category 2 applications for ignition protection type increased safety „e“ accord. EN 60079-7

- for category 1 applications for ignition protection type by housing „ta“ accord. EN 60079-31

- for category 2 applications for ignition protection type by housing „tb“ accord. EN 60079-31

Guidelines designation for device group II (non-firedamp endangered mine workings)

**Designation explosionproof device according to ATEX directive 2014/34/EU**

1.) The monitored electrical equipment does not represent a potential ignition source during normal operation



II (2) G [Ex db Gb] IIC	<b>according to EN 50495 and EN 60079-1</b>
II (1) D [Ex h Ga] IIIC	<b>according to EN 50495 and DIN EN ISO 80079-37</b>
II (2) D [Ex h Da] IIIC	



II (1) G [Ex db Gb] IIC  
 II (1) G [Ex h Ga] IIC  
 II (1) D [Ex h Da] IIIC

Standard designation according to EN 60079-0  
 Explosion group II C gases, low ignition energy such as hydrogen  
 III C conductive dusts

Equipment Protection Level:  
 Gb: for use in zone 1 or 2 for gases  
 Ga: for category 1, zone 0 for gases  
 Da: for use in zone 20, 21 or 22 for dust

Standard series designation according to EN 50495<sup>1)</sup>  
 "db" pressureproof enclosure b = zone 1 or 2 for gas  
 „h" constructive safety

#### Standard designation

Category according to ATEX directive 2014/34/EU  
 G: explosive atmosphere consisting of gas, vapor or mist  
 D: explosive atmosphere consisting of dust

Safety devices according to EN 50495  
 - for category 2 applications for ignition protection type increased safety „e" accord. EN 60079-7  
 - for category 1 applications for ignition protection type by housing „ta" accord. EN 60079-31  
 - for category 2 applications for ignition protection type by housing „tb" accord. EN 60079-31

Guidelines designation for device group II (non-firedamp endangered mine workings)

**Designation explosionproof device according to ATEX directive 2014/34/EU**

1.) The monitored electrical equipment does not represent a potential ignition source during normal operation

### 7.3 Meaning of the X character in the type examination certificate

The particular conditions for which the X follows the test report numbers are as follows:

- Switching operations may be performed on the intrinsically safe electrical circuits only when the JUMO safetyM STB/STW Ex, including all supply lines, is de-energized.
  - Voltage may only be applied to the JUMO safetyM STB/STW Ex, including all its supply lines, if the cover cap of the intrinsically safe electrical circuits has been fitted correctly
- ⇒ Chapter 4.2 "Removing the cover cap"
- For the JUMO probes in the ATEX test report, based on JUMO data sheet 901006 and 902006, a safe isolation between the sensor and fitting does not exist. As a result, for the safety evaluation, the sensor connections are to be considered grounded according to ATEX. This means that the user must ensure that, when connecting the intrinsically safe electrical circuit through integration in the local potential (e.g. potential equalization or FB), the intrinsic safety of the JUMO safetyM STB/STW Ex is not reversed.
  - The probe terminal heads of the probes under consideration do not fulfill the material composition requirements from EN 60079-0 for EPL Ga. Corresponding impact protection must therefore be ensured on site for use in EPL Ga.
- ⇒ Chapter 11.11 "Note about the probes in Chapter to Chapter 11.12"
- Only the STB variant (safety temperature limiter) of the JUMO safetyM STB/STW Ex is admissible as a safety device for monitoring the minimum overpressure in the case of static pressurization.
  - The switch-off limit value must be set depending on the application so that no dangerous state can be adopted even taking into account accuracy, the error tolerance time of the JUMO safetyM STB/STW Ex, and (if applicable) pressure or temperature over-runs.
  - The safety relevant settings of the JUMO safetyM STB/STW Ex must be protected against unauthorized changes (e.g. using a seal or password-protected data input).
  - When using the JUMO safetyM STB/STW Ex in the STW (safety temperature monitor) variant, after the temperature limiter has triggered a shutdown steps must be taken to prevent an automatic restart of the monitored apparatus by a higher-level control system.

- If the JUMO safetyM STB/STW Ex is being used in the single-channel device variant to monitor non-electrical ignition sources and a warning is issued on demand, the user must immediately take the necessary measures to establish a safe status.

### **7.4 Associated, intrinsically safe electrical apparatus according to EN 60079-11**

#### **7.4.1 Function of intrinsic safety**

The ignition protection type intrinsic safety "i" makes use of the fact that a certain energy is required in order to ignite a potentially explosive atmosphere. This is dependent upon the composition of the potentially explosive atmosphere.

An electrical circuit is intrinsically safe if it prevents this energy level from being exceeded, thus preventing an ignition either through switching sparks or a thermal effect, under certain test conditions and taking into consideration certain safety margins.

##### **7.4.1.1 Definitions of intrinsic safety**

An intrinsically safe electrical circuit is a circuit in which neither a spark nor a thermal effect occurring under the conditions specified in EN 60079-11, which include uninterrupted operation and defined fault conditions, may cause the ignition of a certain potentially explosive atmosphere.

The energy of the electrical circuit is limited such that it cannot cause an ignition. This applies to both spark formation and thermal effects. The test conditions with specific potentially explosive atmospheres are specified. The tests comprise uninterrupted operation and defined fault conditions.

##### **7.4.1.2 Electrical apparatus**

Electrical apparatus is the collective term for electrical components and electrical circuits or parts of electrical circuits generally found together within a single housing.

##### **7.4.1.3 Intrinsically safe electrical apparatus**

Electrical apparatus in which all electrical circuits are intrinsically safe.

##### **7.4.1.4 Associated electrical apparatus**

Electrical apparatus in which not all electrical circuits are intrinsically safe. However, in terms of the design, the non-intrinsically

safe electrical circuits cannot have an effect on the intrinsically safe electrical circuits.

The associated apparatus is identified through brackets: e.g. II (1) G [Ex ia] II C.

Associated electrical apparatus can be used in potentially explosive areas provided it has the corresponding protection (ignition protection type according to EN 60079-0). In the event of insufficient protection, it must be used outside of the potentially explosive area.

**Example:**

The JUMO safetyM STB/STW Ex is not in the potentially explosive area, however it is connected to a thermocouple located in the potentially explosive area. Only the input circuit of the JUMO safetyM STB/STW Ex is intrinsically safe.

The screw terminals marked in blue and the connected lines are protected with a cover cap.

**Figure 5: Cover cap**



⇒ Chapter 4.2 "Abnehmen der Abdeckkappe"

### 7.4.2 Probe arrangement in the Ex-area

The JUMO safetyM STB/STW Ex has the following maximum output data at the intrinsically safe inputs:

$U_o = 6.0 \text{ V}$ ;  $I_o = 41.2 \text{ mA}$ ;  $P_o = 61.8 \text{ mW}$ ;  $C_o = 36.3 \text{ }\mu\text{F}$ ;  $L_o = 20 \text{ mH}$

The specified energy values are available as a total amount per device.

The distribution to the inputs is not defined.

Example: Double Pt100 with protection tube constant 80 K/W: temperature increase of 80 K/W x 61.8 mW = 4.9 K.

If a separate temperature increase for dust is specified in the technical data sheet from JUMO, this means that the protection fitting is completely covered in dust.

Figure 6:

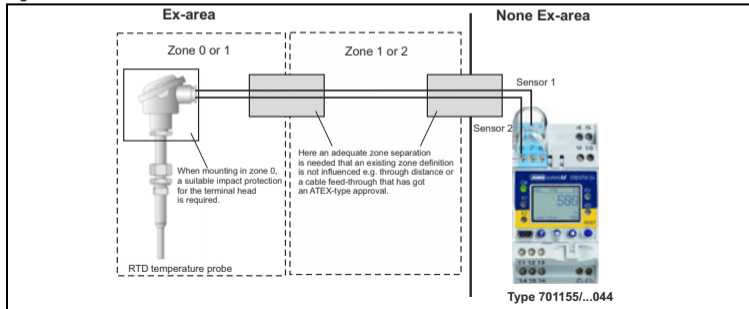



The sensor technology specified in Chapter 11.13 and Chapter 11.14 does not have zone separation.

⇒ Please also see the notes in Chapter 11.11.

The type of zone separation as well as the cable selection must be implemented or selected in such a way that the defined zone classifications and their requirements continue to be in place.

Use of a probe with EPL "Gb" with a separation element (DIN EN 60079-26). The figure shows a probe with active zone separation according to DIN EN 60079-26. Mounting the terminal head in zone 0 is not permitted! However, use in zone 0 is permitted below the separation element. The same requirements as in figure 7 apply for the zone classification.

**Figure 7:**

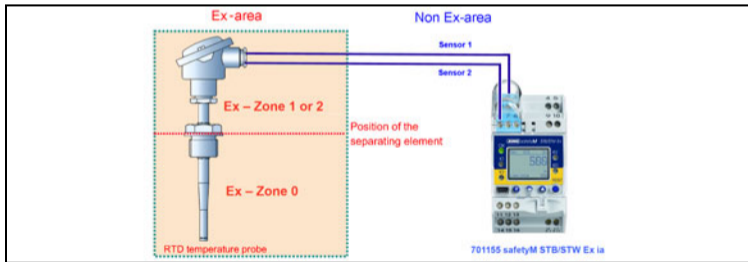

### 7.4.3 Explanation of probe temperature classes

The listed probes can be used in the temperature classes T1 to T6.

**Table 16: Temperature classes**

Temperature class	Maximum surface temperature of the apparatus <sup>1</sup>	Ignition temperature of the combustible materials
T1	450 °C	> 450 °C
T2	300 °C	> 300 < 450 °C
T3	200 °C	> 200 < 300 °C
T4	135 °C	> 135 < 200 °C
T5	100 °C	> 100 < 135 °C
T6	85 °C	> 85 < 100 °C

#### Temperature classes

In EN 60079-0, point 26.5.1.3, type-tested devices of group II (explosive gas atmospheres excluding mines susceptible to fire-damp) require a safety margin for the highest measured surface temperature – 10 K for T1 and T2, and 5 K for T3, T4, T5, and T6.

In RTD temperature probes, a measuring current flows through the sensor element thus heating it up. In the event of a fault in the JUMO safetyM STB/STW Ex, a maximum power of 61.8 mW can also be introduced in the probe through the sensor electrical circuit. This also affects the thermocouple probes.

The maximum temperature rise was calculated through measurements.

The following values represent the worst-case scenario and apply to all probes:

The maximum temperature rise of Pt100 probes is **7.5°K**.

The maximum temperature rise of thermocouple probes is **0.9°K**.

- Furthermore, the following safety margins must be adhered to:  
 Category 1: According to EN 1127-1, point 6.4.2 (hot surfaces), the temperatures of all surfaces of devices...for use in zone 0...which may come into contact with a potentially explosive atmosphere...must not exceed 80 % of the ignition temperature.  
 The result is temperature class minus 20 %.

As described above, 10 °C must be subtracted in temperature classes T1 and T2 and 5 °C in temperature classes T3 to T6.

**Example:**

A thermocouple is to be used in the temperature class T4 (maximum temperature 135 °C, limit is to be reduced by 5 K for safety);

$T_S$  Maximum admissible temperature at the probe head

$$T_S = 130 \text{ °C} - 0.9 \text{ °C}$$

$$T_S = 129.1 \text{ °C}$$

The maximum temperature (measuring or medium temperature) at the probe head must therefore not exceed a value of 129.1 °C.

The following table provides a summary of the calculations for all temperature classes:

**Table 17:**

	Medium and ambient temperature for applications that require category 2 devices		Medium and ambient temperature for applications that require category 1 devices	
	Sensor with PT100	Sensor with thermocouple	Sensor with PT100	Sensor with thermocouple
T1	432.5 °C	439.1 °C	342.5 °C	349.1 °C
T2	282.5 °C	289.1 °C	222.5 °C	229.1 °C
T3	187.5 °C	194.1 °C	147.5 °C	154.1 °C
T4	122.5 °C	129.1 °C	95.5 °C	102.1 °C
T5	87.5 °C	94.1 °C	67.5 °C	74.1 °C
T6	72.5 °C	79.1 °C	55.5 °C	62.1 °C

## 7.5 Safety device according to DIN EN 50495

The standard DIN EN 50495, harmonized within the scope of Directive 2014/34/EU, stipulates requirements for electrical apparatus that performs one or more safety function(s) for explosion protection. Discrete and complex safety devices whose protective function is controlled by software are evaluated using measures from EN 50595. By means of the Safety Integrity Level (SIL) from EN 61508, DIN EN 50495 defines the necessary safety level for monitoring potential ignition sources.

It is important to note the requirement from DIN EN 50495 in Appendix E, which states the following (paraphrased here): *"If a device contains more than one potential ignition source, suitable measures must be applied for each of these ignition sources. Combined apparatus must comply with the relevant standards EN 60079-0 and EN 61241-0 according to the category to be achieved."*

The JUMO safetyM STB/STW Ex is installed outside the apparatus in a non-potentially explosive area. Using e.g. a probe attached in the apparatus, it monitors the temperature of a bearing, which is considered a potential ignition source in the apparatus. The probe lines protruding into the potentially explosive area are intrinsically safe and the JUMO safetyM STB/STW Ex is therefore identified accordingly as "associated apparatus".

⇒ Chapter 7.2 "Identification marking according to ATEX directive 2014/34/EU and EN standards EN 60079-11 "i", EN 50495, and EN ISO 80079-37 "h":")

It is only admissible to increase the fault tolerance (HFT) and thus increase the device category for the combined apparatus using the JUMO safetyM STB/STW Ex if there are no other ignition hazards other than the one addressed by the JUMO STB/STW, and the higher device category poses no additional requirements on the combined apparatus.

The scope of DIN EN 50495 does not include safety devices for non-electrical apparatus, which are recorded in DIN EN ISO 80079-37 (ignition protection type "h") (see Chapter 7.6 in this operating manual).

### 7.5.1 Temperature monitoring unit based on the ignition protection type "e", increased safety, according to EN 60079-7

#### 7.5.1.1 Function of increased safety

Ignition protection type where additional measures are taken to prevent, with an increased degree of safety, the possibility of excessively high temperatures and the occurrence of sparks or electric arcs on or in parts of the electrical apparatus, in which they do not occur during normal operation.

#### **7.5.1.2 Use in the 1-sensor variant**

As described in the table in Chapter 6.6 "Sensor connection possibilities (SIL)" of this operating manual, the JUMO safetyM STB/STW Ex evaluation unit always has the same design and its architecture always has a 1oo2D structure. When connecting only one passive sensor, this corresponds to variant 1 in the table.

According to Chapter 6.9.2 "Safety-relevant system properties" in this operating manual, the "sensor technology" subsystem therefore has a 1oo1 architecture and, thus, a HFT of 0. As a result, in conjunction with the monitored apparatus (as combined apparatus), this variant meets the safety requirements according to DIN EN 50495 for systems that are used in category 2 (zone 1) if the monitored apparatus does not represent an ignition source in standard operation. The requirements from table 1 of DIN EN 50495 apply.

The limit value must be determined according to the respective use or application. The value must be set so that no dangerous state can occur when all relevant factors such as response time and, if applicable, temperature over-run of the monitored apparatus including the JUMO safetyM STB/STW Ex are taken into account.

To ensure that no unintended changes can be made to the configured parameters, the JUMO safetyM STB/STW must be sealed according to Chapter 5.8 in this operating manual, or a keyboard lock or level inhibit must be used according to Chapter 10.4.

#### **7.5.1.3 Use in the 2-sensor variant**

When connecting two passive sensors, this corresponds to variants 1a, 2, 3, and 4 in table 1 in Chapter 6.6 "Sensor connection possibilities (SIL)". According to Chapter 6.9.2 "Safety-relevant system properties" in this operating manual, the "sensor technology" subsystem therefore has a 1oo2 architecture and, thus, a HFT of 1. As a result, in conjunction with the monitored apparatus (as combined apparatus), these variants meet the safety requirements according to DIN EN 50495 for systems that are used in category 1 (zone 0) if the monitored apparatus does not represent an ignition source in standard operation. The requirements from table 1 of DIN EN 50495 apply.

The limit value must be determined according to the respective use or application. The value must be set so that no dangerous state can occur when all relevant factors such as response time and, if applicable, temperature over-run of the monitored apparatus including the JUMO safetyM STB/STW 70155 are taken into account.

To ensure that no unintended changes can be made to the configured parameters, the JUMO safetyM STB/STW must be sealed according to Chapter 5.8 in this operating manual, or a keyboard lock or level inhibit must be used according to Chapter 10.4.

### 7.5.1.4 Use of temperature transmitters

When using temperature transmitters, the safety features are described according to variant 5 in the table in Chapter 6.6 "Sensor connection possibilities (SIL)". The necessary features on the basis of DIN EN 50495 must be reported accordingly for the temperature transmitter. The requirements from table 1 of DIN EN 50495 apply. The signal is fed in via the 4 – 20 mA input. The settings are according to point 8.2.2 and the following.

The limit value must be determined according to the respective use or application. The value must be set so that no dangerous state can occur when all relevant factors such as response time and, if applicable, temperature over-run of the monitored apparatus including the JUMO safetyM STB/STW 70155 and the temperature transmitter are taken into account.

To ensure that no unintended changes can be made to the configured parameters, the JUMO safetyM STB/STW must be sealed according to Chapter 5.8 in this operating manual, or a keyboard lock or level inhibit must be used according to Chapter 10.4.

## **7.6 Ignition source monitoring "h" according to EN ISO 80079-37**

### **7.6.1 Ignition source monitoring „b“**

Type of ignition protection in which mechanical or electrical equipment is used in conjunction with non-electrical equipment to manually or automatically reduce the likelihood that a potential ignition source will become an effective ignition source.

### **7.6.2 Ignition protection system types**

Within DIN EN ISO 80079-37, reference is made to DIN EN ISO 80079-36 for the determination of the monitoring parameters. The use of the ignition protection systems is shown in Table 1 of DIN EN ISO 80079-37. The use of the type b1 and type b2 ignition protection systems is described here. The use of the ignition protection systems b1 or b2 depends on the EPL and the occurrence of the potential ignition source.

Monitoring of a potential ignition source, which may become dangerous during normal operation, is not allowed for EPL Ga and Da (Zone 0 and Zone 20 respectively).

In this case, the concept of the equipment must be revised.

The necessary ignition protection system must be specified in accordance with Table 1 of DIN EN ISO 80079-37.

The necessary information on the JUMO safetyM STB/STW Ex for use in the above-mentioned ignition protection systems is given in Chapter 6.9.2 "Safety-relevant system properties".

### **7.6.3 Application of the ignition protection system types**

The ignition protection system types listed in Table 1 or Table 2 of EN 80079-37 must be applied according to the requirements for the EPL. The EPL can be secured after a warning signal either by manual intervention or by automatic intervention.

The choice of intervention (automatic or manual) is up to the user of the product and depends, among other things, on the choice of the downstream logic device and actuator technology

### **7.6.4 Identification marking**

Safety devices intended to be part of an ignition protection system type b1, b2 and not intended for installation in potentially explosive atmospheres must be marked [Ex h].

## 8 ATEX ignition protection type "e" and "t"

### 8.1 Intended use

The JUMO safetyM STB/STW Ex is a safety device designed according to Directive 2014/34/EU, chapter 1(1)(b) for measuring temperatures directly using resistance probes or thermocouple probes, or other physical measurands such as pressure, with the aid of a suitable transmitter and the use of a 4-20 mA current input.

The stipulations and requirements for use specified in this document must be taken into consideration. All specifications below with regard to probes or sensor technology relate to the probes listed in Chapter 11.11 to Chapter 11.14. If other probes are used, their suitability must first be tested.

Consideration only in accordance with ATEX as an [Ex eb, tb] device and not in accordance with IECEx



#### **Important information:**

Thermocouples should be evaluated with at least the requirements of EN 60584 or DIN 43710. RTD temperature probes should be evaluated with at least the requirements of EN 60751. Parameter values such as response rate, temperature stability, age drift, self-heating behavior, failure rates, fault models, etc. should likewise be taken into account.

The JUMO safetyM STB/STW Ex is associated apparatus that may only be used outside the Ex-zone. Another use or one that goes beyond the specified use - with respect to use in potentially explosive areas - is considered as not being in accordance with the intended use.

Liability for resulting damages cannot be assumed.

The JUMO safetyM STB/STW Ex is built according to the relevant standards and directives as well as to the applicable safety regulations. Nevertheless, improper use may lead to personal injury or material damage.

To avoid danger, the JUMO safetyM STB/STW Ex may only be used:

- For the intended use
- When in good order and condition
- Under consideration of this operating manual

## 8.2 Identification marking according to ATEX directive 2014/34/EU and according to the standards EN 60079-7 "e" and EN 60079-31 "t":

**1-sensor-variant:** Type: 701155/...-045 [Ex „e“, „t“]

	II (2) G (h) [Ex eb Gb] [Ex eb Gb] IIC
	II (2) D (h) [Ex tb Db] [Ex tb Db] IIIC
Standard designation according to EN 60079-0 Explosion group II C gases, low ignition energy such as hydrogen III C conductive dusts	
Standard designation according to EN 50495 eb: increased safety b = zone 1 or 2 for gas tb: protection with housing b = zone 21 or 22 for dust	
Standard designation according to EN 60079 for electrical devices ignition protection „e“ increased safety according to EN 60079-7 ignition protection "t" dust explosion protection with housing accord. to EN 60079-31 Equipment Protection Level: Gb: for use in zone 1 or 2 for gases Db: for use in zone 21 or 22 for dust	
Standard designation according to DIN EN ISO 80079-36 for non electrical devices „h“ ignition source monitoring according to DIN EN ISO 80079-36 with IPL 1 (Ignition Prevention Level) for category 2	
<b>Standard designation</b>	
Category according to ATEX directive 2014/34/EU G: gas explosion protection D: dust explosion protection	
Safety devices according to EN 50495 for category 2 applications for ignition protection level increased safety "e" according to EN 60079-7 Safety devices according to DIN EN ISO 80079-36 for category 2 applications for ignition protection level Ignition source monitoring of non-electrical ignition hazards "t" according to DIN EN ISO 80079-36	
Guidelines designation for device group II (non-fredamp endangered mine workings)	
Designation explosionproof according to ATEX directive 2014/34/EU	

**2-sensor-variant:** Type: 701155/...-045 [Ex „e“, „t“]

	II (2) G (h) [Ex eb Gb] [Ex eb Gb] IIC
	II (2) D (h) [Ex tb Db] [Ex tb Db] IIIC
Standard designation according to EN 60079-0 Explosion group II C gases, low ignition energy such as hydrogen III C conductive dusts	
Standard designation according to EN 50495 eb: increased safety b = zone 1 or 2 for gas tb: protection with housing b = zone 21 or 22 for dust	
Standard designation according to EN 60079 for electrical devices ignition protection „e“ increased safety according to EN 60079-7 ignition protection "t" dust explosion protection with housing accord. to EN 60079-31 Equipment Protection Level: Gb: for use in zone 1 or 2 for gases Db: for use in zone 21 or 22 for dust	
Standard designation according to DIN EN ISO 80079-36 for non electrical devices „h“ ignition source monitoring according to DIN EN ISO 80079-36 with IPL 2 (Ignition Prevention Level) for category 1	
<b>Standard designation</b>	
Category according to ATEX directive 2014/34/EU G: gas explosion protection D: dust explosion protection	
Safety devices according to EN 50495 for category 2 applications for ignition protection type increased safety "e" according to EN 60079-7 Safety devices according to DIN EN ISO 80079-36 for category 2 applications for ignition protection level Ignition source monitoring of non-electrical ignition hazards "t" according to DIN EN ISO 80079-36	
Guidelines designation for device group II (non-fredamp endangered mine workings)	
Designation explosionproof according to ATEX directive 2014/34/EU	

## 8.3 Meaning of the X character in the type examination certificate

If the letter "X" is suffixed to the certificate number, this denotes special conditions governing the safe use of the product in the appendix to the type examination certificate.

- Switching operations may be performed on the electrical circuits (Ex eb) only when the JUMO safetyM STB/STW Ex, including all supply lines, is de-energized.
- Only the STB variant (safety temperature limiter) of the JUMO safetyM STB/STW Ex is admissible as a safety device for monitoring the minimum overpressure in the case of static pressurization.
- The safety relevant settings of the JUMO safetyM STB/STW Ex must be protected against unauthorized changes (e.g. using a seal or password-protected data input).
- When using the JUMO safetyM STB/STW Ex in the STW (safety temperature monitor) variant, after the temperature limiter has triggered a shutdown steps must be taken to prevent an automatic restart of the monitored apparatus by a higher-level control system.
- If the JUMO safetyM STB/STW Ex is being used in the single-channel device variant to monitor non-electrical ignition sources and a warning is issued on demand, the user must immediately take the necessary measures to establish a safe status.
- If it is installed in a separate electrical cabinet, place the following warning on its exterior: WARNING: "Caution - This enclosure contains equipment that is part of an ignition protection system according to ISO 80079-37".

### 8.3.1 Probe arrangement in the Ex-area

The JUMO safetyM STB/STW Ex has the following maximum output data at the intrinsically safe inputs:

$$U_o = 6.0 \text{ V}; I_o = 41.2 \text{ mA}; P_o = 61.8 \text{ mW}; C_o = 36.3 \text{ }\mu\text{F}; L_o = 20 \text{ mH}$$

The specified energy values are available as a total amount per device.

The distribution to the inputs is not defined.

Example: Double Pt100 with protection tube constant 80 K/W: temperature increase of  $80 \text{ K/W} \times 61.8 \text{ mW} = 4.9 \text{ K}$ .

If a separate temperature increase for dust is specified in the technical data sheet from JUMO, this means that the protection fitting is completely covered in dust.

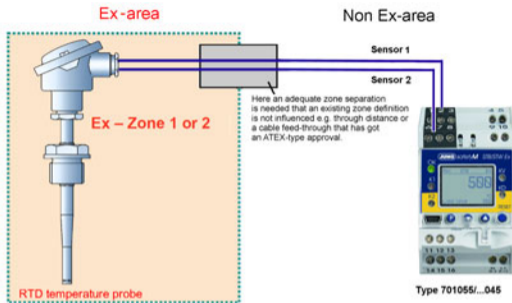

## 9 IECEx

### 9.1 Intended use

The JUMO safetyM STB/STW Ex is associated apparatus that may only be used outside the Ex-zone. Another use or one that goes beyond the specified use - with respect to use in potentially explosive areas - is considered as not being in accordance with the intended use. Consideration according to ATEX as a [Ex i] device

### 9.2 Marking according to IECEx ignition protection type "ia":

The nameplate is glued laterally to the device.



[Ex ia Ga] IIC

Associated apparatus which is set up outside the gas atmosphere but the intrinsically safe electrical circuit "ia" (protection through 2 protective measures) leads into zone 0.

[Ex ia Da] IIIC

Associated apparatus which is set up outside the dust atmosphere but the intrinsically safe electrical circuit "ia" (protection through 2 protective measures) leads into zone 20.

[Ex ia Ga] IIC  
[Ex ia Da] IIIC

Standard designation according to IEC 60079-0  
Explosion group II C gases, low ignition energy such as hydrogen  
III C conductive dusts

Standard designation according to standard series IEC 60079 for electrical devices  
ia: related equipment according to ignition protection "i" intrinsically safe according to IEC 60079-11,  
"ia" (2-failsafe) for category 1  
"EPL" (Equipment Protection Level)  
Ga (gases) for category 1  
Da (dust) for category 1

#### Explanation

### 9.3 Marking according to IECEx ignition protection type „h“



[Ex h Ga] IIC Associated apparatus which is set up outside the gas atmosphere  
[Ex h Da] IIIC Associated apparatus which is set up outside the dust atmosphere

Standard designation according to IEC 60079-0  
Explosion group II C gases, low ignition energy such as hydrogen  
III C conductive dusts

Equipment Protection Level:  
Ga (gases) for category 1, zone 0 for gas  
Da (dust) for category 1, zone 20 for dust

Designation according to standard series EN 80079-37 for non-electrical devices  
"h": related equipment according to ignition protection "h" for category 1

## 9.4 Marking according to IECEx Zündschutzart „d, e, h“ und „t“



[Ex eb Gb] IIC resp. [Ex db Gb] IIC Associated equipment, which is installed outside the gas atmosphere but the circuit (protection by 1 protective measure) leads into zone 1.

[Ex tb Db] IIIC Associated equipment, which is installed outside the dust atmosphere but the circuit (protection by 1-protection measures) leads into zone 21.

[Ex h Gb] IIC

[Ex h Db] IIIC

Standard designation according to EN 60079-0  
Explosion group II C gases, low ignition energy such as hydrogen  
III C conductive dusts.

Equipment Protection Level:  
Gb: for use in zone 1 or 2 for gases  
Db: (dust) for category 1, zone 21 for dust

Standard designation series to EN 60079-7 protection due to increased safety „e“  
and standard designation EN 60079-1 device protection due to flameproof enclosure „d“  
„e“ increased safety for category 2, „b“ zone 1 or 2 for gases  
Standard designation series EN 60079-31 Equipment dust explosion protection by housing „t“  
„t“ dust explosion protection by housing „t“, „b“ zone 21 for dust  
Standard marking according to standards series to EN 80079-37 for non-electrical devices  
„h“ Associated equipment according to type of protection „h“ für category 1

## 9.5 Excerpt of important device data

<b>Contents</b>	<b>Description</b>	<b>Further information</b>
Name of the manufacturer	JUMO GmbH & Co. KG	⇒ See back of this operating manual
Address	Moritz-Juchheim-Straße 1 36039 Fulda Germany	
Description of the test piece Device type	JUMO safetyM STB/STW 701155	⇒ Chapter 2 "Identifying the device version"
Ex identification marking	[Ex ia Ga] IIC [Ex ia Da] IIIC	⇒ Chapter 9.2 "Marking according to IECEx ignition protection type "ia":"
Ex identification marking	[Ex eb Gb] IIC resp.[Ex db Gb] IIC [Ex tb Db] IIIC  [Ex h Gb] IIC [Ex h Db] IIIC	⇒ Chapter 9.4 "Marking according to IECEx Zündschutzart „d, e, h“ und „t“"
Compilation of the ExTR documents and additional information	IECEX Test Report Cover IECEX Test Report: IEC 60079-0 Edition 7 IECEX Test Report: IEC 60079-1 Edition 7 IECEX Test Report: IEC 60079-11, Edition 6 IECEX Test Report: IEC 60079-7 Edition 5.1 IECEX Test Report: IEC 60079-31, Edition 2 IECEX Test Report: IEC 80079-36 Edition 6 IECEX Test Report: IEC 80079-37 Edition 6	⇒ Specified standards
Certificate number	IECEX TUN 15.0036X	⇒ Chapter 18.4 "IECEX TÜV Nord"
Certificate number	IECEX TUN 22.0016X	⇒ Chapter 18.5 "IECEX eurofins"

Contents	Description	Further information
Protection type	Min IP20	⇒ Chapter 11.10 "Housing"
Admissible ambient temperature range (°C)	0 °C to +55 °C	⇒ Chapter 11.9 "Environmental influences"
Special conditions for use of the device „i“	<p>The electrical connection of intrinsically safe electrical circuits must only be established when the device is de-energized.</p> <p>The device, including its cabling, must only be put into operation if the cover cap of the intrinsically safe connection terminals (blue) has been correctly attached.</p>	⇒ Chapter 4.2 "Removing the cover cap" and Chapter 4.3 "Connection diagram"
Special conditions for use of the device „e“ and „t“	<p>Switching operations on the circuits (Ex eb) may only be carried out when the JUMO safetyM STB/STW Ex is de-energized, including all supply lines.</p> <p>Only the STB (safety temperature limiter) variant of the JUMO safetyM STB/STW Ex is suitable as a safety device for minimum overpressure monitoring with static overpressure enclosure.</p> <p>The safety-relevant settings of the JUMO safetyM STB/STW Ex must be protected against unauthorized change (e.g. by sealed or password-protected inputs).</p> <p>When using the JUMO safetyM STB/STW Ex in the STW variant (safety temperature monitor), it must be ensured, that, after a switch-off by the temperature limiter, an automatic restart of the monitored equipment is prevented by a higher-level control system.</p> <p>If the JUMO safetyM STB/STW Ex in the single-channel device version is used for monitoring non-electrical ignition sources and a warning is issued on request the user must take immediate action to achieve a safe condition.</p> <p>If it is installed in a separate electrical cabinet, the following warning must be affixed to the outside of this electrical cabinet: WARNING: "Caution - This enclosure contains equipment that is part of an ignition protection system mach ISO 80079-37".</p>	⇒ Chapter 8.3 "Meaning of the X character in the type examination certificate"



## 10 Configuration level

### 10.1 Navigation principle

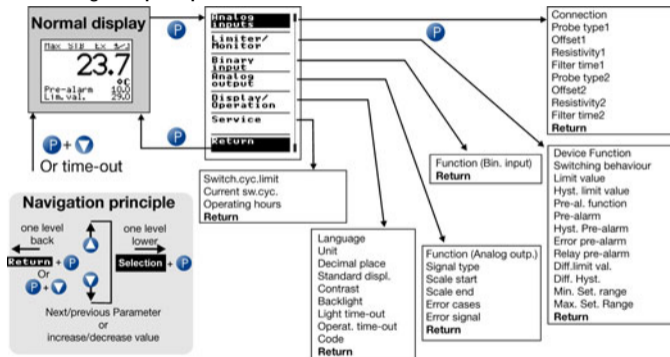



All the parameters are freely accessible ex works, but they can be locked via the setup program.

⇒ Chapter 12.3 "Forgotten the code?"

Parameters of the configuration level which are not required are automatically hidden depending on the setting.

## 10.2 Analog inputs

10.2.1 Connection		Comment
Two sensors		This setting is provided for dual probes or for two different probes. Each of the two analog inputs is monitored separately for a probe break or probe short-circuit.
Single Pt100 in 2-wire circuit		<b>Caution:</b> When only one probe (SIL2) is connected, the temperature limiter device is reduced from <b>SIL3 to SIL2</b> . However, the internal 2-channel structure (1oo2D) in the device still remains. Both channels measure the same sensor due to the simplified external wiring.
Single 4 to 20 mA		<b>Caution:</b> When only one probe (SIL2) is connected, the temperature limiter device is reduced from <b>SIL3 to SIL2</b> . However, the internal 2-channel structure (1oo2D) in the device still remains. Both channels measure the same current signal due to the simplified external wiring.

■ Factory setting

10.2.2 Probe type 1 For analog input1	Comment	Setting range for limit value: (can be restricted via the setup)	Limits for underrange/ overrange
Pt100 DIN EN 60751	In 3-wire circuit IEC 60751:2008	-1999 to +9999 °C	-205 °C/ +855 °C
Pt1000 DIN EN 60751	In 3-wire circuit IEC 60751:2008	-1999 to +9999 °C	-205 °C/ +855 °C
Pt100 DIN EN 60751	in 2-wire circuit IEC 60751:2008	-1999 to +9999 °C	-205 °C/ +855 °C
Pt1000 DIN EN 60751	in 2-wire circuit IEC 60751:2008	-1999 to +9999 °C	-205 °C/ +855 °C
W3Re-W25Re "D"	Thermocouple ASTM E1751M-09 (bis 2315 °C): 2009	-1999 to +9999 °C	-5 to +2500 °C
W5Re-W26Re „C“	Thermocouple ASTM E230M-11: 2011	-1999 ... +9999°C	-5 ... +2320°C
Cu-CuNi "T"	Thermocouple DIN EN 60584-1: 1996-10	-1999 to +9999 °C	-205 to +405 °C
Fe-CuNi "J"	Thermocouple DIN EN 60584-1: 1996-10	-1999 to +9999 °C	-205 to +1205 °C
Cu-CuNi "U"	Thermocouple DIN 43710: 1985-12	-1999 to +9999 °C	-205 to +605 °C
Fe-CuNi "L"	Thermocouple DIN 43710: 1985-12	-1999 to +9999 °C	-205 to +905 °C
NiCr-Ni "K"	Thermocouple DIN EN 60584-1: 1996-10	-1999 to +9999 °C	-205 to +1377 °C
Pt10Rh-Pt "S"	Thermocouple DIN EN 60584-1: 1996-10	-1999 to +9999 °C	-55 to +1773 °C
Pt13Rh-Pt "R"	Thermocouple DIN EN 60584-1: 1996-10	-1999 to +9999 °C	-55 to +1773 °C

10.2.2 Probe type 1 For analog input1	Comment	Setting range for limit value: (can be restricted via the setup)	Limits for underrange/ overrange
Pt30Rh-Pt6Rh "B"	Thermocouple DIN EN 60584-1: 1996-10	-1999 to +9999 °C	295 to 1825 °C
NiCrSi-NiSi "N"	Thermocouple DIN EN 60584-1: 1996-10	-1999 to +9999 °C	-105 to +1305 °C
4 to 20 mA	Standard signal	-1999 to +9999 °C	3.6 to 21 mA

■ Factory setting

Parameter	Comment	Value range (factory setting in <b>bold</b> )
10.2.3 Offset 1	Using Offset1, a measured value at the analog input can be corrected by the value entered over the entire measuring range.	-999.9 to <b>0.0</b> to +999.9
10.2.4 Resistivity 1	<p><b>Analog-input1 lead wire resistance in 2-wire circuit</b></p> <p>This value is used to compensate the resistance of the probe line and depends on the line length. Enter the ohmic resistance of the probe line here to achieve the best possible temperature measurement.</p>	<b>0.0</b> to 30.0 ohm

Parameter	Comment	Value range (factory setting in <b>bold</b> )
<b>10.2.5 Filter time 1</b>	<p><b>Time constant of the digital input filter 2nd order for analog input 1</b></p> <p>If the input signal changes suddenly, approx. 26 % of the change is recorded following a period that corresponds to the filter time constant <math>dF</math> (<math>2 \times dF</math>: approx. 59 %; <math>5 \times dF</math>: approx. 96 %). Value 0 means: filter switched off</p> <p>If the filter time is long: - Interfering signals are better absorbed - Measured value display responds more slowly to changes</p>	0.0 to <b>0.6</b> to 100 sec
<b>10.2.6 Scaling start 1</b>	<p><b>Important information:</b> This setting only occurs if the sensor type 1 was set to 4 to 20 mA.</p> <p>Here, the user selects which value (i.e. pressure) should be displayed at 4 mA.</p>	-9999 to <b>0</b> to +9999
<b>10.2.7 Scaling end 1</b>	<p>Here, the user selects which value (i.e. pressure) should be displayed at 20 mA.</p>	-9999 to <b>100</b> to +9999

10.2.8 Probe type 2 For analog input2	Comment	Setting range for limit value: (can be restricted via the setup)	Limits for underrange/ overrange
Pt100 DIN EN 60751	In 3-wire circuit IEC 60751:2008	-1999 to +9999 °C	-205 °C/ +855 °C
Pt1000 DIN EN 60751	In 3-wire circuit IEC 60751:2008	-1999 to +9999 °C	-205 °C/ +855 °C
Pt100 DIN EN 60751	in 2-wire circuit IEC 60751:2008	-1999 to +9999 °C	-205 °C/ +855 °C
Pt1000 DIN EN 60751	in 2-wire circuit IEC 60751:2008	-1999 to +9999 °C	-205 °C/ +855 °C
W3Re-W25Re "D"	Thermocouple ASTM E1751M-09 (bis 2315 °C): 2009	-1999 to +9999 °C	-5 to +2500 °C
W5Re-W26Re „C"	Thermocouple ASTM E230M-11: 2011	-1999 ... +9999°C	-5 ... +2320°C
Cu-CuNi "T"	Thermocouple DIN EN 60584-1: 1996-10	-1999 to +9999 °C	-205 to +405 °C
Fe-CuNi "J"	Thermocouple DIN EN 60584-1: 1996-10	-1999 to +9999 °C	-205 to +1205 °C
Cu-CuNi "U"	Thermocouple DIN 43710: 1985-12	-1999 to +9999 °C	-205 to +605 °C
Fe-CuNi "L"	Thermocouple DIN 43710: 1985-12	-1999 to +9999 °C	-205 to +905 °C
NiCr-Ni "K"	Thermocouple DIN EN 60584-1: 1996-10	-1999 to +9999 °C	-205 to +1377 °C
Pt10Rh-Pt "S"	Thermocouple DIN EN 60584-1: 1996-10	-1999 to +9999 °C	-55 to +1773 °C
Pt13Rh-Pt "R"	Thermocouple DIN EN 60584-1: 1996-10	-1999 to +9999 °C	-55 to +1773 °C

<b>10.2.8 Probe type 2</b> For analog input2	<b>Comment</b>	<b>Setting range for limit value:</b> <b>(can be restricted via the setup)</b>	<b>Limits for underrange/ overrange</b>
Pt30Rh-Pt6Rh "B"	Thermocouple DIN EN 60584-1: 1996-10	-1999 to +9999 °C	295 to 1825 °C
NiCrSi-NiSi "N"	Thermocouple DIN EN 60584-1: 1996-10	-1999 to +9999 °C	-105 to +1305 °C
4 to 20 mA	Standard signal	-1999 to +9999 °C	3.6 to 21 mA

■ Factory setting

<b>Parameter</b>	<b>Comment</b>	<b>Value range</b> <b>(factory setting in bold)</b>
<b>10.2.9 Offset 2</b>	Using Offset2, a measured value at the analog input can be corrected by the value entered over the entire measuring range.	-999.9 to <b>0.0</b> to +999.9
<b>10.2.10 Resistivity 2</b>	<b>Analog-input2 lead wire resistance in 2-wire circuit</b> This value is used to compensate the resistance of the probe line and depends on the line length. Enter the ohmic resistance of the probe line here to achieve the best possible temperature measurement.	<b>0.0</b> to 30.0 ohm

Parameter	Comment	Value range (factory setting in <b>bold</b> )
<b>10.2.11 Filter time 2</b>	<p><b>Time constant of the digital input filter 2nd order for analog input 2</b></p> <p>If the input signal changes suddenly, approx. 26 % of the change is recorded following a period that corresponds to the filter time constant <math>dF</math> (<math>2 \times dF</math>: approx. 59 %; <math>5 \times dF</math>: approx. 96 %). Value 0 means: filter switched off</p> <p>If the filter time is long:</p> <ul style="list-style-type: none"> <li>- Interfering signals are better absorbed</li> <li>- Measured value display responds more slowly to changes</li> </ul>	0.0 to <b>0.6</b> to 100 sec
<b>10.2.12 Scaling start 2</b>	<p><b>Important information:</b> This setting only occurs if the sensor type 2 was set to 4 to 20 mA.</p> <p>Here, the user must select which value (e.g. pressure) should be displayed at 4 mA.</p>	-9999 to <b>0</b> to +9999
<b>10.2.13 Scaling end 2</b>	<p>Here, the user must select which value (e.g. pressure) should be displayed at 20 mA.</p>	-9999 to <b>100</b> to +9999

### 10.3 Limiter/monitor

Parameter	Comment	Value range (factory setting in <b>bold</b> )
<b>10.3.1 Device function</b>	<p>Safety temperature limiter (<b>STB</b>) <b>initial startup</b>: Regardless of the switching status of the alarm relay output prior to power failure, the STB remains locked when power returns.</p> <p>The purpose of this factory setting is to ensure that the device will be in a safe switched-off state when the voltage supply is switched on for the first time. After this initial startup, the device function can be set to STB or STW.</p>	<b>STB initial startup, STB, STW</b>
	<p>Safety temperature limiter <b>STB</b>:</p> <p>The device must be manually reset using the keypad or the binary input as soon as the main measured value is back within the valid range.</p>	
	<p>Safety temperature monitor <b>STW</b>:</p> <p>The device is automatically reset as soon as the main measured value is back within the valid range.</p>	

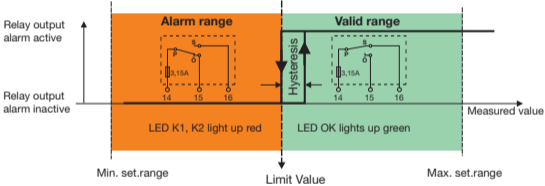
Parameter	Comment	Value range (factory setting in <b>bold</b> )
<b>10.3.2 Switching behavior</b>	<b>Min. alarm:</b> If the value falls below the limit value, the alarm relay output switches OFF. LEDs K1 and K2 light up red and the measured values flash on the display.	<b>Max. alarm</b> , min. alarm
<p data-bbox="59 308 477 339"><b>Min. alarm</b> (older devices: S-Function)</p>  <p data-bbox="49 760 1086 909">In the safety temperature limiter (<b>STB</b>) setting, this condition remains even when the main measured value is back in the valid range. Only when the <b>RESET</b> key is pressed or a switch is activated when the binary input is respectively configured will the alarm relay output switch ON again and the OK LED light up green. In the safety temperature monitor (<b>STW</b>) setting, the alarm relay output automatically switches back to ON as soon as the main measured value is back within the valid range.</p>		

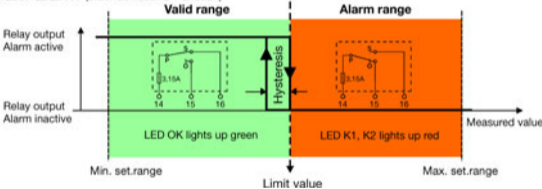
Parameter	Comment	Value range (factory setting in <b>bold</b> )
	<p><b>Max. alarm:</b> If the value exceeds the limit value, the alarm relay output switches OFF. LEDs K1 and K2 light up red and the measured values flash on the display.</p>	
<p><b>Max. alarm</b> (older devices: O-Function)</p>  <p>In the safety temperature limiter (<b>STB</b>) setting, this condition remains even when the main measured value is back in the valid range. Only when the <b>RESET</b> key is pressed or a switch is activated when the binary input is respectively configured will the alarm relay output switch ON again and the OK LED light up green.</p> <p>In the safety temperature monitor (<b>STW</b>) setting, the alarm relay output automatically switches back to ON as soon as the main measured value is back within the valid range.</p>		

Parameter	Comment	Value range (factory setting in <b>bold</b> )
<b>10.3.3 Limit value, hysteresis</b>	<b>Limit value alarm:</b> If this value is exceeded or not reached, this affects the alarm relay output depending on the switching behavior.	-200 to <b>0</b> to +850 Depends on setting range min. and max.
	<b>Hysteresis limit value:</b> Difference between the switch-off and switch-on threshold, e.g. for rising and falling temperatures.	0 to <b>2</b> to 100
<b>10.3.4 Pre-alarm function</b>   The pre-alarm responds according to its setting to the main measured value	<b>No function</b> Pre-alarm relay output is inactive	<b>No function,</b> Absolute value, Limit val. dist. Absolute value inverse Gap limit value inverse Window Window inverse
<b>Absolute value:</b> Pre-alarm relay output is triggered if the value for the pre-alarm is exceeded.		
<b>Limit val. dist.</b>  Here, the set value for the pre-alarm is used on a basis that is relative to the limit value. If, for example, a pre-alarm of 10 K is entered, the pre-alarm relay output always switches at 10 K before the limit value, regardless of how the limit value is set.		

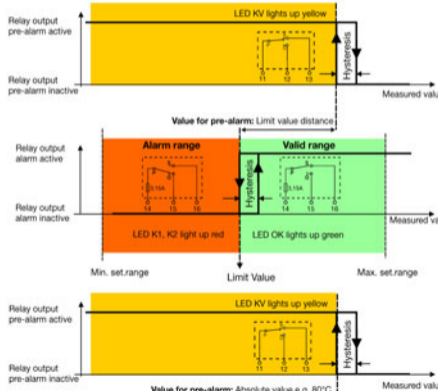
Parameter	Comment	Value range (factory setting in <b>bold</b> )
<p>Switching behavior of the relay output pre-alarm for the Min-Alarm setting</p> <p><b>Min. alarm</b> (older devices: S-Function)</p>  <p>The diagrams illustrate the switching behavior of the relay output pre-alarm for the Min-Alarm setting. The top diagram shows a yellow region where LED KV lights up yellow, indicating the pre-alarm is active. The middle diagram shows an orange 'Alarm range' where LED K1, K2 light up red, and a green 'Valid range' where LED OK lights up green. The bottom diagram shows a yellow region where LED KV lights up yellow, indicating the pre-alarm is active. The diagrams show hysteresis and measured value axes.</p> <p>Value for pre-alarm: Limit value distance</p> <p>Value for pre-alarm: Absolute value e.g. 80°C</p>		

Parameter	Comment	Value range (factory setting in <b>bold</b> )
Switching behavior of the relay output pre-alarm for the Max-Alarm setting		
<b>Max. alarm</b> (older devices: O-Function)		
<p>The diagrams illustrate the switching behavior of the relay output pre-alarm for the Max-Alarm setting. They show the relationship between the measured value and the relay output state (pre-alarm active/inactive) across different alarm ranges and hysteresis levels.</p> <p><b>Top Diagram: Function pre-alarm: Limit value distance</b>      - Background: Yellow (LED KV lights up yellow)      - Y-axis: Relay output pre-alarm active (top), Relay output pre-alarm inactive (bottom)      - X-axis: Measured value      - A dashed box shows a hysteresis loop between points 11, 12, and 13. The text 'Function pre-alarm: Limit value distance' is present.</p> <p><b>Middle Diagram: Valid range and Alarm range</b>      - Y-axis: Relay output Alarm active (top), Relay output Alarm inactive (bottom)      - X-axis: Measured value      - A green region labeled 'Valid range' (LED OK lights up green) is bounded by 'Min. set.range' and 'Limit value'.      - An orange region labeled 'Alarm range' (LED K1, K2 lights up red) is bounded by 'Limit value' and 'Max. set.range'.      - Dashed boxes show hysteresis loops between points 14, 15, 16 and 17, 18, 19.</p> <p><b>Bottom Diagram: Function pre-alarm: Absolute value</b>      - Background: Yellow (LED KV lights up yellow)      - Y-axis: Relay output pre-alarm active (top), Relay output pre-alarm inactive (bottom)      - X-axis: Measured value      - A dashed box shows a hysteresis loop between points 11, 12, and 13. The text 'Function pre-alarm: Absolute value' is present.      - Below the x-axis: Value for pre-alarm: Absolute value e.g. 80°C</p>		

Parameter	Comment	Value range (factory setting in <b>bold</b> )
The behavior of the relay output pre-alarm depends on the setting Min-Alarm or Max-Alarm.	<b>Absolute value inverse:</b> The pre-alarm possesses <b>inverse switching behavior</b> in comparison to the "Absolute value" setting and becomes active if the value for pre-alarm is exceeded.	
	<b>Gap limit value inverse:</b> Here, the set value for pre-alarm is used as a distance to the limit value. The pre-alarm possesses <b>inverse switching behavior</b> in comparison to the "Limit val. dist." setting.	

Parameter	Comment	Value range (factory setting in <b>bold</b> )
Switching behavior of the relay output pre-alarm for the Min-Alarm setting		
<b>Min-Alarm</b> (older devices: S-Function)		
Function pre-alarm: <b>Gap limit value inverse</b>		
Value for pre-alarm: Limit value distance		
Alarm range      Valid range		
Relay output alarm active		
Relay output alarm inactive		
LED K1, K2 light up red      LED OK lights up green		
Min. set.range      Limit Value      Max. set.range		
Function pre-alarm: <b>Absolute value inverse</b>		
Value for pre-alarm: Absolute e.g. 80°C		
Measured value		

Parameter	Comment	Value range (factory setting in <b>bold</b> )
Switching behavior of the relay output pre-alarm for the Max-Alarm setting		
<p><b>Max. alarm</b> (older devices: O-Function)</p> <p>The diagrams illustrate the switching behavior of the relay output pre-alarm for the Max-Alarm setting. The top diagram shows the 'Function pre-alarm: Gap limit value inverse' where the relay output pre-alarm is active (LED KV lights up yellow) when the measured value is above a limit value. The middle diagram shows the 'Function pre-alarm: Absolute value inverse' where the relay output alarm is active (LED OK lights up green) in a 'Valid range' and LED K1, K2 lights up red in an 'Alarm range' above a 'Limit value'. The bottom diagram shows the 'Function pre-alarm: Absolute value inverse' where the relay output pre-alarm is active (LED KV lights up yellow) when the measured value is below a 'Value for pre-alarm: Absolute value e.g. 80°C'.</p>		

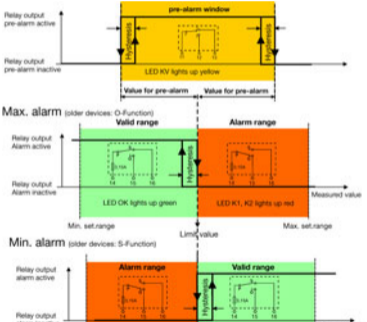
Parameter	Comment	Value range (factory setting in <b>bold</b> )
	<p><b>Window:</b></p> <p>The set pre-alarm value determines the window width symmetrically around the limit value. Here it is irrelevant if Min-Alarm or Max-Alarm is set.</p>	
<p>In a window symmetrically around the limit value the pre-alarm relay is active.</p>  <p>The diagrams illustrate the alarm logic based on the measured value relative to the limit value and the set range.</p> <ul style="list-style-type: none"> <li><b>pre-alarm window:</b> Shows a yellow shaded region centered on the limit value. The width is determined by the 'Value for pre-alarm' on both sides. The relay output is active (up) within this window, and LED KV lights up yellow.</li> <li><b>Max. alarm (pidter devices: O-Function):</b> Shows a green 'Valid range' to the left of the limit value and an orange 'Alarm range' to the right. The relay output is active (up) in the alarm range, and LED K1, K2 lights up red.</li> <li><b>Min. alarm (pidter devices: S-Function):</b> Shows an orange 'Alarm range' to the left of the limit value and a green 'Valid range' to the right. The relay output is active (up) in the alarm range.</li> </ul>		

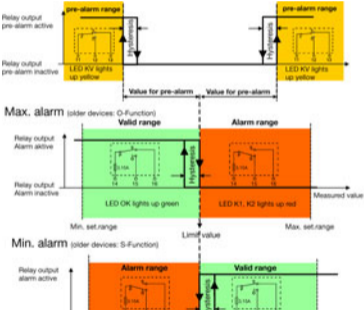
Parameter	Comment	Value range (factory setting in <b>bold</b> )
	<p><b>Window inverse:</b></p> <p>The pre-alarm possesses <b>inverse switching behavior</b> in comparison to the "Window".</p>	
<p>In a window symmetrically around the limit value the pre-alarm relay is inactive.</p> 	<p>Caution</p> <p>The pre-alarm function is <b>not part of the safety function!</b></p>	



Parameter	Comment	Value range (factory setting in <b>bold</b> )
<b>10.3.5 Pre-alarm, hysteresis</b>	<b>Pre-alarm:</b> The value that triggers the pre-alarm relay output as an absolute value or relative to the limit value.	-9999 to <b>0</b> to +9999
	<b>Pre-alarm hysteresis:</b> Difference between the switch-off and switch-on threshold, e.g. for rising and falling temperatures.	0 to <b>2</b> to 100
<b>10.3.6 Error Pre-alarm, Relay pre-alarm</b>	<b>Error pre-alarm:</b> Here the user can define to which errors the pre-alarm should react. - Sensor error: see Chapter 8.5 "Measuring circuit monitoring" - Sens.error&diff.: same as sensor error above with additional errors of differential monitoring. - All errors: additional device errors see Chapter 11.	Sensor error <b>Sens.error&amp;diff.</b> All errors
	<b>Relay pre-alarm:</b> Here the user can set which condition the relay output pre-alarm should have when the errors above occur.	<b>Active</b> Inactive
<b>10.3.7 Limit value difference, hysteresis</b>	<b>Limit value difference monitoring:</b> If the value of the temperature difference of the analog input 1-2 is exceeded, the alarm relay output is switched.	0 to <b>50</b> to 100
	<b>Hysteresis difference monitoring:</b> Difference between the switch-off and switch-on threshold, e.g. for rising and falling differential values.	0 to <b>2</b> to 100
<b>Important information:</b>		
If, for example, temperature differences arise as a result of the spatial arrangement of a dual probe, an alarm may be triggered by the concurrency monitoring even though the temperature being monitored has not yet been exceeded. In this case, the difference monitoring limit value can be adjusted accordingly.		

Parameter	Comment	Value range (factory setting in <b>bold</b> )
<p><b>10.3.8 Setting range min. (formerly ALHI)</b></p> <p>This is the lower limit of the setting range for the limit value.</p>	<p>This value may not be lower than the lower end of the connected probe or unit signal measuring range. It may also not be set higher than the setting for the <b>alarm limit value</b>.</p>	<p>-9999 to <b>-200</b> to limit value °C</p>
<p><b>10.3.9 Setting range max. (formerly ALLO)</b></p> <p>This is the upper limit of the setting range for the limit value.</p>	<p>This value may not be greater than the higher end of the connected probe or unit signal measuring range. It may also not be set lower than the setting for the <b>alarm limit value</b>.</p>	<p>Limit value to <b>850</b> to 9999 °C</p>

The admissible limits for DIN approved probes:

- ⇒ Chapter "" and
- ⇒ Chapter 11.13 "Probes for water and oil"

## 10.4 Binary input

Parameter	Comment	Value range (factory setting in <b>bold</b> )
<b>10.4.1 Function</b>	This sets the function that should be controlled by the binary input.	
	The binary input does not have a function	<b>No function</b>
	The binary input performs a reset as described in Chapter 10.3.1 "Device function" The function only responds to the switching edge from "open" to "closed" state.	Unlocking
	Protection against unauthorized key operation	Key lock
	Configuration level is locked.	Level inhibit

■ Factory setting

## 10.5 Analog output

Parameter	Comment	Value range (factory setting in <b>bold</b> )
<b>10.5.1 Function</b>	Here, the measured value that is to be shown at the analog output is set.	<b>Main measured value</b> Measured value1 Measured value2 Difference
	<b>Main measured value:</b> With the max. alarm switching behavior, the greater of the two measured values is shown; with the min. alarm, the lower of the two measured values is shown.	
	<b>Measured value1:</b> Measured value of analog input 1 (E1) is shown	
	<b>Measured value2:</b> Measured value of analog input 2 (E2) is shown	
	<b>Difference:</b> E1-E2 is shown The signal that should be output by the analog output can be set with scaling start and end.	
<b>10.5.2 Signal type</b>	4 to 20 mA	<b>4 to 20 mA</b> 0 to 20 mA 2 to 10 V 0 to 10 V
	0 to 20 mA	
	2 to 10 V	
	0 to 10 V	
<b>10.5.3 Scaling start</b>	⇒ Figure in Chapter 10.5.7	-9999 to <b>-200</b> to +9999
<b>10.5.4 Scaling end</b>	⇒ Figure in Chapter 10.5.7	-9999 to <b>800</b> to +9999

Parameter	Comment	Value range (factory setting in <b>bold</b> )
<b>10.5.5 Error cases</b>	<p>Various error cases can be configured for the analog output, for which the analog output reacts with the configured error signal:</p> <p><b>Sensor error 2x</b> means: If a sensor error of the corresponding channel (see Chapter 10.5.1, the analog output goes into the error case. Only with function main value both channels must be faulty, if one channel is ok it will be is ok, this channel will be output.</p> <p><b>Sensor error 1x</b> means: If there is a sensor error of the corresponding channel (see Analog output Function) is present, the analog output goes into error mode.</p> <p><b>Sens.err&amp; Diff.</b> (factory setting) If there is a sensor error of the corresponding channel (see Analog output Function) is present or when the difference limit value is exceeded (independent of the "Analog output function" parameter), the analog output goes into the error mode.</p> <p><b>All errors</b> If there is a sensor error of the corresponding channel (see Chapter 10.5.1) or in case of exceeding of the limit value difference (independent of the "Analog output function" parameter) or in case of internal device device errors, then the analog output goes into error mode.</p>	<p>Sensor error 2x Sensor error 1x <b>Sens.err. &amp; diff.</b> All Errors</p>
<b>10.5.6 Error signal</b>	<p>If, for the measured value 1 or 2, the value is exceeded, not reached, or a diagnostic error occurs, the current or voltage value set on the analog output is output as a so-called error signal.</p>	
	For signal type 4 to 20 mA	<b>3.4</b> or 21.2 mA
	For signal type 0 to 20 mA	<b>0</b> or 21.2 mA
	For signal type 2 to 10 V	<b>1.7</b> or 10.4 V
	For signal type 0 to 10 V	<b>0</b> or 10.4 V

### 10.5.7 Behavior when leaving the scaling range

The standard signal range of the analog output is limited as follows according to the recommendation of Namur NE 43:

Signal type	Lower limit	Upper limit
0: 4 to 20 mA	3.8 mA	20.5 mA
1: 0 to 20 mA	0 mA	20.5 mA
2: 2 to 10 V	1.8 V	10.2 V
3: 0 to 10 V	0 V	10.2 V

■ Factory setting

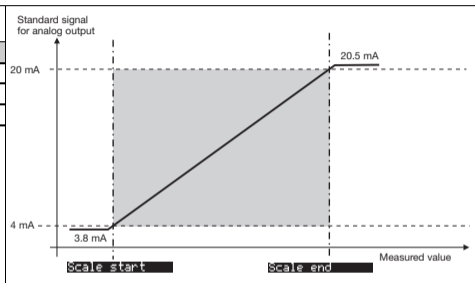



Caution

The analog output is **not part of the safety function**.

## 10.6 Display/operation

Parameter	Comment	Value range (factory setting in <b>bold</b> )
<b>10.6.1 Language</b>	German	<b>German</b> , English, French
	English	
	French	
<b>10.6.2 Unit</b>   If the unit is changed to °F, the measured value is converted. All other values referring to the measured value (e.g. limit value) remain unchanged.	A unit for the measured value can be assigned here.	°C, °F, %, text
	°C	
	°F	
	%	
	Text: Via the setup program, 2 characters can be entered here for another unit, e.g. Pa (Pascal).	
<b>10.6.3 Decimal place</b>	No decimal place	<b>No decimal place</b> , One decimal place
	One decimal place	
<b>10.6.4 Normal display</b>	This sets the view that appears after the voltage supply is switched on. ⇨ Chapter "Operating overview"	<b>Main measured value</b> , measured values, limit value, pre-alarm, difference
	Main measured value	
	Measured values	
	Limit value	
	Pre-alarm	
	Difference	

Parameter	Comment	Value range (factory setting in <b>bold</b> )
<b>10.6.5 Contrast</b>	<b>Screen contrast:</b> Difference in brightness between black and white pixels	0 to <b>5</b> to 10
<b>10.6.6 Backlight</b>	Here, the background lighting of the display is set. <b>Off:</b> Always switched off <b>On:</b> Always switched on <b>During operation:</b> The background lighting is only switched on when the keys are operated and it lights up until the time for the time-out light has expired.	Off, <b>On</b> , During operation
<b>10.6.7 Time-out light</b>	Here, a waiting period for the switch-off of the background lighting is set.	0 to <b>30</b> to 100 sec
<b>10.6.8 Time-out operation</b>	Here, the waiting period is set for the return from the configuration to normal display.	0 to <b>30</b> to 100 sec
<b>10.6.9 Code</b>	To protect against unauthorized manipulations, a code can be set here for locking the configuration level. 0 means: code request switched off   If the code is forgotten, a new code can be transferred to the device via the setup program.   Chapter 12.3 "Forgotten the code?"	<b>0</b> to 9999

## 10.7 Service

Parameter	Comment	Value range (factory setting in <b>bold</b> )
<b>10.7.1 Limit switching cycle</b>	<b>Limit value for relay switching cycles</b> Here, the limit value for the admissible relay switching cycles is set. If the counter value for <b>Current switching cycles</b> is greater than this value, the display values flash and the alarm relay output drops out. If "0" is set the function is inactive.	<b>0</b> to 99999
<b>10.7.2 Current switching cycles</b>	<b>Relay switching cycle counter</b> Here, the switching cycles for the relay are only counted if the top <b>limit value for relay switching cycles</b> is not set to "0" and is thus inactive. The value can then be adjusted as required and therefore adapted accordingly to the plant. The switching cycle counter remains at 99999.	<b>0</b> to 99999
<b>10.7.3 Operating hours</b>	<b>Operating hours counter</b> The counter adds up the operating hours during which the device was connected to the voltage supply. The value cannot be changed and can be used as a measure of how long the device was actually in operation after leaving the factory.	<b>0</b> to 99999

## 11 Technical data

### 11.1 Analog inputs

#### RTD temperature probe

Designation	Measuring range	Accuracy 2/3-wire circuit <sup>1</sup>	Ambient temperature influence
Pt100 IEC 60751:2008	-200 to +850 °C	0.5 % / 0.1 %	50 ppm/K
Pt1000 IEC 60751:2008	-200 to +850 °C	0.5 % / 0.1 %	50 ppm/K
Connection type	Maximum line resistance in two-wire circuit: 15 Ω; three-wire circuit: 30 Ω		
Sampling rate	210 ms		
Error tolerance time	≤ 5 s time taken into account for all diagnostic tests		
Input filter	Digital filter, 2nd order; filter constant can be set from 0 to 100 s		
Special features	Individual probe Pt100 2-wire, display can also be programmed in °F		

#### Thermocouples

Designation	Measuring range	Accuracy <sup>1</sup>	Ambient temperature influence
Fe-CuNi "L" DIN 43710: 1985-12	-200 to +900 °C	0.4 %	100 ppm/K
Fe-CuNi "J" DIN EN 60584-1:1996-10	-200 to +1200 °C	0.4 %	100 ppm/K

Cu-CuNi "U" DIN 43710:1985-12	-200 to +600 °C	0.4 %	100 ppm/K
Cu-CuNi "T" DIN EN 60584-1:1996-10	-200 to +400 °C	0.4 %	100 ppm/K
NiCr-Ni "K" DIN EN 60584-1:1996-10	-200 to +1372 °C	0.4 %	100 ppm/K
Pt10Rh-Pt "S" DIN EN 60584-1:1996-10	-50 to +1768 °C	0.4 %	100 ppm/K
Pt13Rh-Pt "R" DIN EN 60584-1:1996-10	-50 to +1768 °C	0.4 %	100 ppm/K
Pt30Rh-Pt6Rh "B" DIN EN 60584-1:1996-10	0 to 1820 °C	0.4 % <sup>2</sup>	100 ppm/K
NiCrSi-NiSi "N" DIN EN 60584-1:1996-10	-100 to 1300 °C	0.4 % <sup>2</sup>	100 ppm/K
W3Re-W25Re "D" ASTM E1751M-09 (up to 2315 °C): 2009	0 to 2495 °C	0.4 %	100 ppm/K
W5Re-W26Re "C" ASTM E230M-11: 2011	0 to 2315 °C	0.4 %	100 ppm/K
Cold junction	Pt100 internal		
Cold junction accuracy	± 1 K		
Sampling rate	210 ms		
Error tolerance time	≤ 5 s time taken into account for all diagnostic tests		
Input filter	Digital filter, 2nd order; filter constant can be set from 0 to 100 s		

1. The accuracy refers to the maximum measuring range.

2. The accuracy specifications are only guaranteed as of 300 °C.

**Direct current**

Measuring range	Accuracy	Ambient temperature influence
4 to 20 mA, voltage drop < 2 V	0.2 %	150 ppm/K
Scaling	Can be freely programmed within the limits	
Sampling rate	210 ms	
Error tolerance time	≤ 5 s time taken into account for all diagnostic tests	
Input filter	Digital filter, 2nd order; filter constant can be set from 0 to 100 s	
Special features	Individual probe 4 to 20 mA	

**11.2 Analog output**

	Signal type	Accuracy	Residual ripple	Load influence	Temperature influence	Load resistance
Current <sup>a</sup>	4 to 20 mA	≤ 0.5 %	± 0.5 % at 300 Ω	± 0.05 mA / 100 Ω	150 ppm/K	≤ 500 Ω
	0 to 20 mA					
Voltage	2 to 10 V	≤ 0.5 %	± 0.5 %	± 15 mV	150 ppm/K	≥ 500 Ω
	0 to 10 V					

a. Zero point adjustment at 270 Ω

**11.3 Digital input**

Connection	Function
------------	----------

1 potential-free contact	Unlocked, keyboard lock, level inhibit can be configured
--------------------------	--

## 11.4 Relay outputs

Relay output KV	Relay (changeover contact) without contact protection 30000 switching operations at a switching capacity of AC 250 V, 3 A, 50 Hz (resistive load) or max. DC 30 V, 3 A. Minimum current: DC 12 V / 100 mA.
Alarm relay output	Relay (changeover contact) <b>Contact protection circuit:</b> fuse cut-out 3.15 AT, installed in the N/O contact arm 30000 switching operations at a switching capacity of <b>AC 230 V, 3 A</b> , 50 Hz (resistive load) or max. <b>DC 30 V, 3 A</b> . Minimum current: DC 12 V / 100 mA. (The contact load of 8 A specified by the manufacturer is thus reduced by 60%, which means that the fault exclusion of contact welding is complied with).

## 11.5 Measuring circuit monitoring

	RTD temperature probe in three-wire circuit and double thermocouples	Thermocouples	Current 4 to 20 mA
Out of range	Is detected LED K1, K2, KD, and KV are lit; ">>>>" flashes in the display for overrange, "<<<<" for underrange.		
Probe/cable break	Is detected LED K1, K2, KD, and KV are lit; ">>>>" flashes in the display; alarm relay output is disabled		LED K1, K2, KD, and KV are lit; ">>>>" flashes in the display; alarm relay output is disabled
Probe short circuit	Is detected LED K1, K2, KD, and KV are lit; "<<<<" flashes in the display; alarm relay output is disabled	Is detected by difference monitoring of the analog inputs ⇒ Chapter 10.3.7 "Limit value difference, hysteresis"	LED K1, K2, KD, and KV are lit; "<<<<" flashes in the display; alarm relay output is disabled

## 11.6 Voltage supply

Voltage supply	AC/DC 20 to 30 V, 48 to 63 Hz	AC 110 to 240 V, 48 to 63 Hz	+10/-15 %
Power consumption, power loss	Max. 12 W	Max. 12 W	
Power consumption, power loss: For the following operating mode Analog output 10 mA (ohm); display backlight off; limit value relay switched on; pre-alarm relay switched off; sensor: 2xPt100	5 W	5 W	

## 11.7 Test voltages according to EN 60730, Part 1

Input and output against voltage supply	
- With a voltage supply AC 110 to 240 V +10 % /-15 %	3.7 kV/50 Hz
- With a voltage supply AC/DC 20 to 30 V, 48 to 63 Hz	3.7 kV / 50 Hz

## 11.8 Electrical safety

	<b>Clearances / creepage distances</b>
Mains voltage to electronic components and probes	$\geq 6 \text{ mm} / \geq 8 \text{ mm}$
Mains voltage to relays	$\geq 6 \text{ mm} / \geq 8 \text{ mm}$
Relays to electronic components and probes	$\geq 6 \text{ mm} / \geq 8 \text{ mm}$
Electrical safety	According to DIN EN 14597 (DIN EN 60730-2-9) Overvoltage category III, pollution degree 2
Protection rating I	With internal isolation from SELV electrical circuits

## 11.9 Environmental influences

Ambient temperature range	0 to +55 °C
Storage temperature range	-30 to +70 °C
Site altitude	maximum 2000 m above MSL
Temperature influence	$\leq \pm 0.005 \% / \text{K dev. from } 23 \text{ }^\circ\text{C}^1$ for RTD temperature probes
	$\leq \pm 0.01 \% / \text{K dev. from } 23 \text{ }^\circ\text{C}^1$ for thermocouple and current

Terminal temperature range	If the temperature range between -10 °C and +80 °C is exceeded or not reached, the device displays the "Terminal temperature" error message. The output changes to a safe state (quiescent current principle). The message can only be acknowledged if the temperature has moved back into the valid range.
Resistance to climatic conditions	85 % rel. humidity without condensation (3K3 with extended temperature range according to DIN EN 60721-3-3)
EMC	According to DIN EN 14597 and standards from the standards series DIN EN 61326
Interference emission	Class B
Interference immunity	Evaluation criteria FS according to DIN EN 14597, regulation and control devices (RS)

1.All specifications refer to the measuring range end value

## 11.10 Housing

Material	Polycarbonate
Flammability class	UL 94 V0
Electrical connection	On the front via screw terminals up to max. 2.5 mm <sup>2</sup>
Mounting	On 35 mm DIN rail according to DIN EN 60715
Installation position	Vertical
Weight	Approx. 230 g
Protection type	IP 20 according to DIN EN 60529

## 11.11 Note about the probes in Chapter to Chapter 11.12

Within the scope of the type examination TÜV 11 ATEX 556139 X, the temperature sensors according to 901006 and 902006 were regarded as simple electrical equipment and may be operated within the specified limits with the STB 701155 in the Ex area within the specified limits. The specified limit values can be seen in the type examination TÜV 11 ATEX 556139 X. These temperature sensors 901006... and 902006... are marked with the extra code .../922 and the type examination certificate number 11 ATEX 556139 X.

The following should be noted:

- A safe isolation between the sensor and fitting does not exist. As a result, the sensor connections are to be considered grounded for the safety evaluation.
- Among other things, EN 60079-0 requires for the EPL Ga that the mass fraction of aluminum must be less than 10 % for the manufacture of metallic housings. The probe terminal head used by JUMO contains more than 10 % aluminum. The terminal head must therefore be secured by suitable impact protection for the use of EPL Ga (zone 0). The impact protection must reliably prevent friction sparks, contact-breaking sparks, and impact sparks. Otherwise there is a risk of ignitable sparks.
- The installation instructions for probes must be observed.

No other precautions have to be taken when used in EPL Gb (zone 1).

### 11.11.1 Instructions for replacing protective sleeves or sensors

When putting into operation after delivery of temperature sensors without thermowell/protective sleeve (e.g. in case of sensor replacement), the additional marking on the sensor (type flag) must be observed.

It is important that the thermowell or pocket is also checked for cleanliness (e.g. foreign bodies, chips, etc.), corrosion and damage corrosion and damage.

Furthermore, all points of the chapter "Recommended tests for temperature sensors" must be observed.

⇒ Chapter 6.16.1 "Recommended tests for temperature probes"

### 11.11.2 Further connection options

Another possibility to connect sensors in hazardous areas to the 701155 would be the interconnection with intrinsically safe equipment, which are tested as such (independently) and marked according to EN 60079-0.

## 11.12 Probes for the operating medium air

**Note:** because of the response accuracy, **the use of thermowells** (immersion sleeves) **is not admissible**.

Type designation	Probe Type	Temperature range	xxx = Nom. length in mm	Process connection
<b>RTD temperature probe</b> data sheet 902006				
902006/65-228-1003-1-15-xxx-668/922	1 x Pt100	-170 ... +700°C	500, 710, 1000	movable compression clamp
902006/55-228-1003-1-15-xxx-254/922	1 x Pt100	-170 ... +700°C	500, 710, 1000	movable compression clamp G1/2
902006/65-228-2003-1-15-xxx-668/922	2 x Pt100	-170 ... +700°C	500, 710, 1000	movable compression clamp
902006/55-228-2003-1-15-xxx-254/922	2 x Pt100	-170 ... +700°C	500, 710, 1000	movable compression clamp G1/2
<b>Thermocouples</b> data sheet 901006				
901006/65-547-2043-15-xxx-668/922	2 x NiCr-Ni, Type „K“	-35 ... +800°C	500, 710, 1000	movable compression clamp
901006/65-546-2042-15-xxx-668/922	2 x Fe-CuNi, Type „L“	-35 ... +700°C	500, 710, 1000	
901006/66-550-2043-6-xxx-668/922	2 x NiCr-Ni, Type „K“	-35 ... +1000°C	250, 355, 500	
901006/66-880-1044-6-xxx-668/922	1 x PT10Rh-PT, Type „S“	0 ... 1300°C	250, 355, 500	

Type designation	Probe Type	Temperature range	xxx = Nom. length in mm	Process connection
901006/66-880-2044-6-xxx-668/922	2 x PT10Rh-PT, Type „S“	0 ... 1300°C	250, 355, 500	movable compression clamp
901006/66-953-1046-6-xxx-668/922	1 x PT30Rh-PT6Rh, Type „B“	600 ... 1500°C	250, 355, 500	
901006/66-953-2046-6-xxx-668/922	2 x PT30Rh-PT6Rh, Type „B“	600 ... 1500°C	250, 355, 500	

### 11.13 Probes for water and oil

**Note:** because of the response accuracy, **the use of thermowells** (immersion sleeves) **is not admissible**.

Type designation	Probe type	Temperature range	Nom. length mm	Process connection
<b>RTD temperature probe</b> data sheet 902006				
902006/10-226-1003-1-9-250-104/922	1 x Pt100	-40 ... +480°C	250	G1/2 compression clamp
902006/10-226-2003-1-9-250-104/922	2 x Pt100		250	
902006/54-227-2003-1-15-710-254/922	2 x Pt100	-170 ... 550°C	65...670	movable G1/2 compression clamp
902006/54-227-1003-1-15-710-254/922	1 x Pt100		65...670	
902006/10-402-1003-1-9-100-104/922	1 x Pt100	-170 ... 400°C	100	G1/2 compression clamp
902006/10-402-2003-1-9-100-104/922	2 x Pt100		100	
902006/10-402-1003-1-9-150-104/922	1 x Pt100		150	
902006/10-402-2003-1-9-150-104/922	2 x Pt100		150	
902006/10-402-1003-1-9-200-104/922	1 x Pt100		200	
902006/10-402-2003-1-9-200-104/922	2 x Pt100		200	
<b>Thermocouples</b> data sheet 901006				
901006/54-544-2043-15-710-254/922	2 x NiCr-Ni, Type „K“	-35 ... 550°C	65...670	movable G1/2 compression clamp
901006/54-544-1043-15-710-254/922	1 x NiCr-Ni, Type „K“		65...670	
901006/54-544-2042-15-710-254/922	2 x FeCuNi, Type „L“		65...670	
901006/54-544-1042-15-710-254/922	1 x FeCuNi, Type „L“		65...670	

**Note:** Because of the response accuracy, only use thermowells (pockets) that are **included in the scope of delivery**

Type designation	Probe type	Temperature range	Nom. length mm	Process connection
<b>RTD temperature probe</b> data sheet 902006				
902006/53-505-2003-1-12-190-815/922	2 x Pt100	-40 ... +400 °C	190	weld-in sleeve
902006/53-505-1003-1-12-190-815/922	1 x Pt100	-40 ... +400 °C	190	
902006/53-507-2003-1-12-100-815/922	2 x Pt100 (im Schutzrohr untereinander angeordnet)	-40 ... +480 °C	100, 160, 190, 220	
902006/53-507-1003-1-12-100-815/922	1 x Pt100	-40 ... +480 °C	100, 160, 220	
902006/53-505-3003-1-12-100-815/922	3 x Pt100	-40 ... +400 °C	100, 160, 220	
902006/40-226-1003-1-12-220-815/922	1 x Pt100	-170 ... +480°C	100, 160, 220	
<b>Thermocouples</b> data sheet 901006				
901006/53-543-1042-12-220-815/922	1 x Fe-CuNi Type „L“	-35 ... 480°C	220	weld-in sleeve
901006/53-543-2042-12-220-815/922	2 x Fe-CuNi Type „L“		220	

## 11.14 Probes for air, water, and oil

**Note:** because of the response accuracy, **the use of thermowells** (immersion sleeves) **is not admissible**

Type designation	Probe type	Temperature range	Nom. length	Process connection
<b>RTD temperature probe</b> data sheet 902006				
902006/10-390-1003-1-8-250-104/922	1 x Pt100	max. 300°C	Nom. length: 250 mm	Screw-in thread G1/2
<b>Thermocouples</b> data sheet 901006				
901006/45-551-2043-2-EL-11-AL/922	2 x NiCr-Ni, Type „K“	max. 1150°C	50 < EL < 2000 1000 < AL < 20000	



### Attention:

A probe short circuit can only be detected with a double thermocouple.

## 12 Setup program

The program and the connecting cable are available as accessories and offer the following possibilities:

- Simple and convenient parameterization and archiving via PC
- Easy parameter duplication for identical types of devices

### 12.1 Minimum hardware and software requirements:

- PC Pentium III or higher
- 128 MB RAM, 16 MB free on hard disk
- CD-ROM drive
- Free USB interface, mouse connection
- Microsoft<sup>1</sup> Windows XP, VISTA, WIN7 and 8 with 32 or 64 Bit

\* Connect the device to the PC using the USB cable

### 12.2 Displaying the device software version

\* Simultaneously press the **P** and **A** keys and hold down

This version is also recognized by the setup program and displayed under *Info* ⇒ *Information about setup*.

The software versions of the device and the setup program must be compatible as otherwise an error message will appear!

1. Microsoft is a registered trademark of Microsoft Corporation

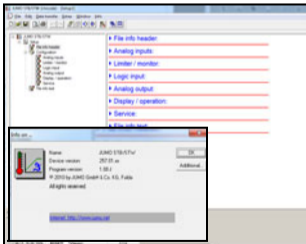

## 12.3 Forgotten the code?

If you forget the code, it can be read out via the USB interface and the setup program.

\* Use *Data transfer*  $\Rightarrow$  *from device*.

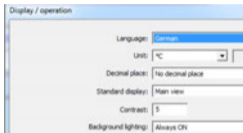

The read-out code now appears in the setup program.

It can be kept as it is or changed.

If "0" is set and transferred to the device, the code interrogation is disabled and the configuration level is freely accessible.

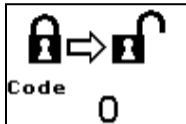

## 12.4 Special function: thermocouple reverse-polarity protection

If the polarity of a thermocouple is reversed, measured values are shown that do not reflect the real situation, for example, negative temperatures may be displayed instead of the expected positive temperatures.

This may lead to the set limit value never being reached. For this purpose, an additional limit value is defined at  $-205\text{ °C}$  by default, which triggers the alarm relay if the value falls below this.

A suitable value must be selected here so that it is possible to detect potential reverse polarity.

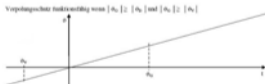

Grenzwert einstellbar:  $A_0$   $-9999\text{ °C}$  bis  $+9999\text{ °C}$   $\pm 0,1\text{ °C}$   
 Grenzwert Vorgabegrenze einstellbar:  $A_0$   $-205\text{ °C}$  bis  $+200\text{ °C}$   $\pm 0,1\text{ °C}$   
 Grenzwert Differenzmessung einstellbar:  $A_0$   $0\text{ °C}$  bis  $100\text{ °C}$   
 Im Falle der asymmetrischen Vorgabe der Sensork., schaltet der STB die Anlage beim Erreichen des Differenzgrenzwertes der Anlage sicher ab.  
 Im Falle der symmetrischen Vorgabe wird dem STB fallende Temperatur auf den schaltenden Kanälen signalisiert. Wird der Vorgabegrenzwert erreicht, schaltet der STB sicher die Anlage ab.

## 12.5 Displaying a pressure signal via the current input

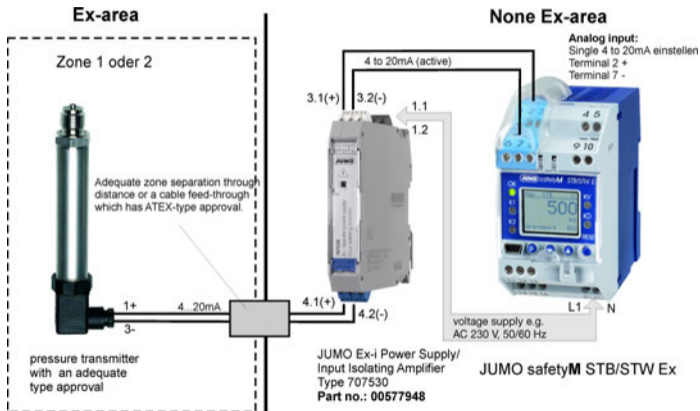

The pressure signal is acquired by a pressure transmitter in the form of a 4 to 20 mA standard signal, which is supplied via an active supply isolating amplifier. The signal is fed into the passive analog input of the JUMO safetyM STB/STW Ex.

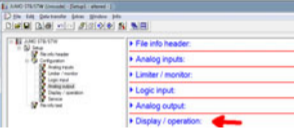

## 12.5.1 Configuration of a pressure signal using the setup program

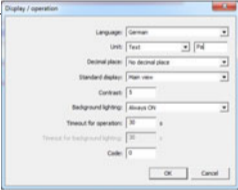

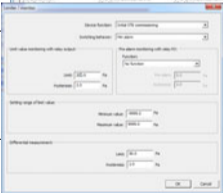

Step	Action	Description
1	* Connect the device to the PC via USB and start the setup program	 The screenshot shows the JUMO SETUP software window. On the left, a tree view shows the configuration structure: 'JUMO SETUP' -> 'Menu' -> 'File info header' -> 'Configuration' -> 'Analog inputs' -> 'Analog header' -> 'Logic input' -> 'Analog output' -> 'Display / operation' -> 'Service' -> 'Miscellaneous'. On the right, a list of menu items is shown with red arrows pointing to each: 'File info header:', 'Analog inputs:', 'Limiter / monitor:', 'Logic input:', 'Analog output:', and 'Display / operation:'. A red arrow points to the 'Display / operation:' item.
2	* In the "Display/Operation" menu, set <b>Text and Pa</b> for the unit and acknowledge with OK	

Step	Action	Description
3	<ul style="list-style-type: none"> <li>* In the "Analog input" menu, set <b>single 4 to 20 mA</b>; further input fields for scaling are then shown</li> <li>* Enter <b>start: 0</b> and <b>end: 500</b> for both channels and acknowledge with OK</li> </ul>	
4	<ul style="list-style-type: none"> <li>* In the "Limiter/Monitor" menu, set <b>STB</b> or <b>Initial STB commissioning</b> and the switching behavior to <b>Min. alarm</b> and acknowledge with OK</li> <li>* Enter the desired <b>limit value</b> (in Pa) and <b>hysteresis</b></li> </ul>	

Step	Action	Description
5	<p><b>* Transfer data to the device</b> A summary of the parameters appears</p>	
6	<p><b>* Once the data has been successfully transferred, disconnect the USB connection.</b></p>	
7	<p>The device now displays a pressure of between 0 and 500 Pa. If the pressure drops to below 200 Pa, the alarm relay output is switched off.</p>	

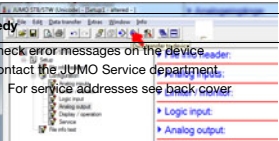
## 13 Alarm messages

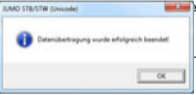
They can appear as follows:

Alarm display	Cause	Remedy
<p>5 flashing horizontal lines:</p> 	<p><b>Measured value error</b> No valid value can be displayed</p>	<p><b>Remedy</b></p> <ul style="list-style-type: none"> <li>* Check error messages on the device</li> <li>* Contact the JUMO Service department</li> </ul> <p>⇒ For service addresses see back cover</p> 
	<p><b>Measured value overrange</b> The measured value is too high, is outside the measuring range or the probe is broken.</p>	<ul style="list-style-type: none"> <li>* Change the display to 2 measured values This makes it possible to detect which channel is defective.</li> <li>* Check the probe and connecting cable for damage or short-circuit</li> </ul> <p>⇒ Chapter 4.3 "Connection diagram"</p>
	<p><b>Measured value underrange</b> The measured value is too low, is outside the measuring range or a short-circuit occurred at the probe.</p>	<p>⇒ Chapter 4.3 "Connection diagram"</p> <ul style="list-style-type: none"> <li>* Check that the probe is correctly connected</li> </ul> <p>⇒ Chapter 4.3 "Connection diagram"</p> 
<p>5 flashing asterisks:</p> 	<p><b>Display overflow</b> Value cannot be displayed</p>	<ul style="list-style-type: none"> <li>* Check error messages on the device</li> <li>* Contact the JUMO Service department</li> </ul> <p>⇒ For service addresses see back cover</p> 

## 14 Error messages

These error messages are displayed one below the other.

Error display (Err)	Origin	Cause/remedy
	Internal	<p>The set limit value for relay switching cycles has been reached</p> <ul style="list-style-type: none"> <li>* Increase limit value of the relay switching cycles</li> </ul> <p>⇒ Chapter 10.7.1 "Limit switching cycle"</p> <p>A check mark appears instead of the bell and the error message can be acknowledged</p>
Terminal temp.	Internal	<p>The internal Pt100 is defective<sup>1</sup>, or the terminal temperature is outside the admissible range (-10 to 80 °C).</p> <p>The message cannot be acknowledged until it is within the valid range again.</p>
Reference volt. <sup>1</sup>	Internal	<p>The reference voltage is outside the valid range.</p> <p>The message cannot be acknowledged until it is within the valid range again.</p>
Calibration const. <sup>1</sup>	Internal	<p>A calibration constant is outside the valid range.</p> <p>The message cannot be acknowledged until it is within the valid range again.</p>
Configuration	Internal	<p>Configuration data outside the value range.</p> <p>The message cannot be acknowledged until it is within the valid range again.</p>
Measured value	Internal	<p>The measured value 1 or 2 is outside the valid range.</p> <p>The message cannot be acknowledged until it is within the valid range again.</p>

<b>Error display (Err)</b>	<b>Origin</b>	<b>Cause/remedy</b>
Measured value missing	Internal	When the error status "Measured value" is signaled by the channel, the diagnosis function tries to show the precise error on the basis of the read measured value.
Probe short-circ.	External	
Meas. overr.		
Meas. underr.		
Probe break		
Operating access <sup>1</sup>	Internal	The diagnosis function is communicating with the STB/STW. The message cannot be acknowledged until communication has finished.
Setup access	Internal	The setup program is communicating with the STB/STW. The message cannot be acknowledged until communication has finished.
CRC calibr. <sup>1</sup>	Internal	Checksum error of the EEPROM calibration data. The message cannot be acknowledged until it is within the valid range again.
CRC config. <sup>1</sup>	Internal	Checksum error of the EEPROM configuration data. The message cannot be acknowledged until it is within the valid range again.
Registry <sup>1</sup>	Internal	A registry error has occurred. The message cannot be acknowledged until the error has been remedied.
RAM defective <sup>1</sup>	Internal	A RAM error has occurred. The message cannot be acknowledged until the error has been remedied.
ROM defective <sup>1</sup>	Internal	A ROM error has occurred. The message cannot be acknowledged until it is within the valid range again.
Program sequence <sup>1</sup>	Internal	A program sequence error has occurred. The message cannot be acknowledged until the error has been remedied.

<b>Error display (Err)</b>	<b>Origin</b>	<b>Cause/remedy</b>
Watchdog <sup>1</sup>	Internal	A watchdog reset has occurred. The message can be acknowledged.
Overvoltage <sup>1</sup>	Internal	The uncontrolled secondary voltage supply is too high. The message can be acknowledged.
Frequency <sup>1</sup>	Internal	Error of the independent time base. The message can be acknowledged
EEPROM defective <sup>1</sup>	Internal	Error during internal communication with the EEPROM. The message can be acknowledged.
Stack <sup>1</sup>	Internal	Error in the memory area reserved for the stack. The message cannot be acknowledged until it is within the valid range again.
AD converter <sup>1</sup>	Internal	Error during internal communication with the A/D converter. The message can be acknowledged
Simulation <sup>1</sup>	Internal	Error during the measured value simulation. The message can be acknowledged.
Zero point <sup>1</sup>	Internal	The zero point voltage of the A/D converter is too low. The message can be acknowledged.
Limit value	Plant	The configured limit value has been exceeded or undershot.

<b>Error display (Err)</b>	<b>Origin</b>	<b>Cause/remedy</b>
<b>Diagnosis function</b>		
FLASH defective <sup>1</sup>	Internal	An error was detected during the cyclic memory test of the ROM.
RAM defective <sup>1</sup>	Internal	An error was detected during the cyclic memory test of the RAM.
CRC config. <sup>1</sup>	Internal	An error was detected by the checksum test (CRC16) in the configuration of the diagnosis function.
CRC calib. <sup>1</sup>	Internal	An error was detected by the checksum test (CRC16) in the calibration data of the diagnosis function.
Configuration	Internal	The configuration contains invalid data.
SW version <sup>1</sup>	Internal	The software versions are invalid.
Editing	Internal	An error has occurred during editing.
V too low	Internal	The internal voltage supply value has fallen below the permitted range.
V too high	Internal	The permitted range of the internal voltage supply has been exceeded.
Int. communic. <sup>1</sup>	Internal	An error has occurred during internal communication.
No access to channels	Internal	One or both channels/the communication to the channels is defective/disrupted.
Difference	Plant	The difference (channel 1 minus channel 2) of the measured values has exceeded the maximum permitted value.
Switching cycles	Internal	The configured limit of the switching cycles has been exceeded. (There is only one counter as all alarm relays always switch) The error can be acknowledged by reducing the current counter or increasing the limit. (So that the switching cycles are not accidentally set to 0 in the event of further errors)

Error display (Err)	Origin	Cause/remedy
USB communic.	Internal	An error has occurred during USB communication.



## Footnote 1

If the error cannot be acknowledged despite repeated switching off and on, the device must be repaired by JUMO.

\* Return the device

⇒ For service addresses see back cover

## 15 What to do, if ...

Description	Cause	Remedy
<p>The following appears in the display:</p> 	<p><b>Setup program transmits data.</b> The monitoring function switches off briefly during data transmission and the device restarts.</p>	<ul style="list-style-type: none"> <li>- Wait until data transmission has finished</li> </ul>
<p>The measured value flashes in the top display.</p> 	<p><b>The device is in the alarm range</b> LEDs K1, K2 are lit red. The measured value flashes in the display and is higher or lower than the limit value depending on the switching behavior set.</p> <ul style="list-style-type: none"> <li>- Measured value too high or too low</li> <li>- Excessive deviation between the temperature values during difference monitoring</li> </ul>	<ul style="list-style-type: none"> <li>* Check the limit value in the configuration level.</li> <li>* Find out the reason for the overrange or under-range</li> <li>* If necessary, correct the limit value</li> <li>* If necessary reduce the excessively high hysteresis, as it may be too far into the valid range.</li> </ul> <p>⇒ Chapter 10.3.3 "Limit value, hysteresis"</p>
<p>LED K1 is lit red, although the measured value is in the valid range</p>	<p><b>The device is set as a safety temperature limiter (STB).</b> Even if the measured value is already back in the valid range after an overrange, the relay of a temperature monitor does not automatically reset. It must be unlocked manually.</p>	<ul style="list-style-type: none"> <li>* Press the ● (RESET) key for longer than 3 seconds to manually unlock the relay.</li> </ul> <p>⇒ Chapter 5.5 "Acknowledging alarms using the reset key (for temperature limiter STB only)"</p>

Description	Cause	Remedy
... alarm relay output between terminal 14 and 16 is not closed although the OK LED is lit green (in the valid range).	- The integrated fuse cut-out is defective, caused by an excessive relay current.	* Measure terminal 14 and 16 of the relay when the LED K1 is lit green using a continuity test device. * The device must be repaired by JUMO if no continuity can be measured. ⇒ For service addresses see back cover
... the display is dark, only the LEDs are lit	- Display shut-down after timeout was activated.	* Press any key or switch off timeout. ⇒ Chapter 10.6.8 "Time-out operation"

## 16 Information for devices with extra code 062 DNV GL

The following information supplements or replaces the existing specifications.

### 16.1 Technical data

#### Tests carried out

Product(s) approved by this certificate is/are accepted for installation on all vessels classed by DNV.

#### Location Class:

Temperature B

Humidity B

Vibration A

EMC B

Enclosure A

### 16.2 Alarm messages

⇒ Chapter 13 "Alarm messages"

### 16.3 Locks

The configuration level can be locked with a code.

⇒ Chapter 10.6.9 "Code"

Intentional or unintentional adjustments are not possible without additional measures.

⇒ Chapter 5.8 "Sealing the device"



For servicing, the device must be returned to the main factory. According to the recommendation of DNV, the availability of a replacement device should be ensured for certain applications.



It is recommended to enclose a printout of the configuration parameters (setup program) and the technical documents for the JUMO safetyM STB/STW Ex (connection diagram) on-site (request them if necessary).

## 17 Behavior of outputs

Operating status	Alarm relay output	Pre-alarm relay output KV	Analog output
Initialization			
Initialization phase after mains voltage – ON (for approx. 10 seconds)	Disabled	Disabled	0 mA, 0 V
Setup communication			
During reading-writing of the configuration (for approx. 5 seconds)	Disabled	Pre-alarm monitoring active ⇒ Chapter 10.3.4	Scaled analog signal is output ⇒ Chapter 10.5
Standard operation			
<b>System in error-free state after initialization phase</b> (STB initial startup)	Disabled, unlocking possible	Pre-alarm monitoring active ⇒ Chapter 10.3.4	Scaled analog signal is output ⇒ Chapter 10.5
System in error-free state after initialization phase (STB, STW)	Monitoring of the limit value active ⇒ Chapter 10.3.2		
External error			
Probe break, probe short circuit (e.g. input 1)	Disabled	Pre-alarm error and pre-alarm relay configurable ⇒ Chapter 10.3.6	Malfunctions configurable ⇒ Chapter 10.5.5 Error signal is output ⇒ Chapter 10.5.6

Operating status	Alarm relay output	Pre-alarm relay output KV	Analog output
After probe break, probe short circuit (STW)	Monitoring of the limit value active ⇒ Chapter 10.3.2	Pre-alarm monitoring active ⇒ Chapter 10.3.4	Scaled analog signal is output ⇒ Chapter 10.5
After probe break, probe short circuit (e.g. input 1) (STB)	Disabled, unlocking possible		
After acknowledgement of probe break, probe short circuit (STB)	Monitoring of the limit value active ⇒ Chapter 10.3.2		
Difference monitoring through diagnostics			
Difference – alarm (STW function)	Disabled	Pre-alarm error and pre-alarm relay configurable ⇒ Chapter 10.3.6	Malfunctions configurable ⇒ Chapter 10.5.5 Error signal is output ⇒ Chapter 10.5.6
Difference – alarm disabled again (STW function)	Monitoring of the limit value active ⇒ Chapter 10.3.2	Pre-alarm monitoring active ⇒ Chapter 10.3.4	Scaled analog signal is output ⇒ Chapter 10.5
Difference – alarm (STB function)	Disabled	Pre-alarm error and pre-alarm relay configurable ⇒ Chapter 10.3.6	Malfunctions configurable ⇒ Chapter 10.5.5 Error signal is output ⇒ Chapter 10.5.6

<b>Operating status</b>	<b>Alarm relay output</b>	<b>Pre-alarm relay output KV</b>	<b>Analog output</b>
Difference – alarm disabled again (STB function)	Disabled, unlocking possible	Pre-alarm monitoring active ⇒ Chapter 10.3.4	Scaled analog signal is output ⇒ Chapter 10.5
After acknowledgement of difference – alarm (STB function)	Monitoring of the limit value active ⇒ Chapter 10.3.2		
<b>Internal error</b>			
Internal error – diagnostics channel active	Disabled	Pre-alarm monitoring active ⇒ Chapter 10.3.4	Scaled analog signal is output ⇒ Chapter 10.5
Internal error – diagnostics channel disabled again	Monitoring of the limit value active ⇒ Chapter 10.3.2		
Internal error – safety channel active (STB)	Disabled	Pre-alarm error and pre-alarm relay configurable ⇒ Chapter 10.3.6	Malfunctions configurable ⇒ Chapter 10.5.5 Error signal is output ⇒ Chapter 10.5.6
Internal error – safety channel disabled again (STB)	Disabled, unlocking possible	Pre-alarm monitoring active ⇒ Chapter 10.3.4	Scaled analog signal is output ⇒ Chapter 10.5
Internal error – safety channel after acknowledgement (STB)	Monitoring of the limit value active ⇒ Chapter 10.3.2		







**Translation**
**EU-Type Examination Certificate**

- (2) Equipment and protective systems intended for use in potentially explosive atmospheres, Directive 2014/34/EU
- (3) Certificate Number: **TUV 11 ATEX 996139 X** Issue: **00**
- (4) For the product: **Safety Temperature limiter / safety temperature monitor JUNMO safetyM STS/TW type 701155 / ... .. -23 / ... .. and type 701156 / ... .. -25 / ... ..**
- (5) of the manufacturer: **JUNMO GmbH & Co. KG**  
 Address: **Moritz-Juchelshelm-Strasse 1, 36039 Fulda, Germany**  
 Order number: **6003014933**  
 Date of issue: **2021-10-12**
- (7) The design of this product and any acceptable variation thereto are specified in the schedule to this EU-Type Examination Certificate and the documents therein referred to.  
 The TÜV NORD CERT GmbH, Notified Body No. 0044, in accordance with Article 17 of the Directive 2014/34/EU of the European Parliament and the Council of 26 February 2014, certifies that this product has been found to comply with the Essential Health and Safety Requirements relating to the design and construction of products intended for use in potentially explosive atmospheres given in Annex II to the Directive. The examination and test results are recorded in the confidential ATEX Assessment Report No. 20 203 261400.
- (9) Compliance with the Essential Health and Safety Requirements has been assured by compliance with:  
**EN IEC 60079-0:2018**      **EN ISO 80079-36:2016**      **EN 60496:2010**  
**EN 60079-11:2012**      **EN ISO 80079-37:2016**
- (10) except in respect of those requirements listed at item 18 of the schedule.  
 If the sign "X" is placed after the certificate number, it indicates that the product is subject to the Specific Conditions for Use specified in the schedule to this certificate.
- (11) This EU-Type Examination Certificate relates only to the design and construction of the specified product. Further requirements of the Directive apply to the manufacturing process and supply of this equipment. These are not covered by this certificate.
- (12) The marking of the product shall include the following:  
 II (1) 0 [Ex Ia Ga] IIC or II (1) 0 [Ex Ia Da] IIC or  
 II (1) 0 [Ex h Ga] IIC or II (1) 0 [Ex h Da] IIC or  
 II (2) 0 [Ex eb Db] IIC or II (2) 0 [Ex Ia Da] IIC or  
 II (2) 0 [Ex tb Db] IIC or II (2) 0 [Ex eb Db] IIC

TÜV NORD CERT GmbH, Am TÜV 1, 46507 Essen, notified by the central office of the countries for safety engineering

(ZLS) under No. 0044, legal successor of the TÜV NORD CERT GmbH & Co. KG (brand No. 0033)

The deputy of the head of the notified body

**Meyer**  TÜV NORD  
 TÜV NORD CERT GmbH  
 Essen, 46507 Essen

Headquarter office, Am TÜV 1, 32019 Hannover, Tel. +49 511 996-61405, Fax +49 511 996-61590

**18.2 ATEX TÜV Nord**



Schedule to EU-Type Examination Certificate No. TÜV 11 ATEX 556139 X Issue 00

**Electrical data:**

For types 3TR351TW 791156 / .. .. . 23 / .. .  
 Supply circuit only for the connection to a non-iteratively safe circuit with a safety-related maximum voltage of

 $U_n = 110$  up to 240 V a.c. +10% / -15%, 48 up to 63 Hz  
 $U_n = 264$  V

For types 3TR351TW 791156 / .. .. . 25 / .. .

Supply circuit only for the connection to a non-iteratively safe circuit with a safety-related maximum voltage of

 $U_n = 20$  up to 30 V d.c. or a.c. 48 up to 63 Hz  
 $U_n = 250$  V

**For all types:**

Binary connection only for the connection to a non-iteratively safe circuit with a safety-related maximum voltage of

 $U_n = 250$  V

Analogue connection only for the connection to a non-iteratively safe circuit with a safety-related maximum voltage of

 $U_n = 250$  V

Relay connection only for the connection to a non-iteratively safe circuit with a safety-related maximum voltage and current of

 $U_n = 250$  V  
 $I_{n0} = 3$  A

Relay connection only for the connection to a non-iteratively safe circuit with a safety-related maximum voltage and current of

 $U_n = 250$  V  
 $I_{n0} = 3$  A

USB connection only for the connection to a non-iteratively safe circuit with a safety-related maximum voltage and current of

 $U_n = 250$  V

Output circuit In type of protection intrinsic safety Ex ia IIC resp. Ex ia IIIC with the following maximum values per circuit:

 $U_n = 6$  V  
 $I_n = 41,2$  mA  
 $P_n = 0,1$  g mW

Characteristic See: Snear

 The effective internal capacitance  $C_n$  is 3,7 µF.

 The effective internal inductance  $L_n$  is negligibly small.

Schedule for EU-Type Examination Certificate No. TÜV 11 ATEX 556139 X Issue 00

The maximum permissible values for the external inductance  $L_e$  and the external capacitance  $C_e$  have to be taken from the following table:

Ex Ia IIC	$L_e$ [mH]		$C_e$ [µF]	
	$L_e$ [mH]	$C_e$ [µF]	$L_e$ [mH]	$C_e$ [µF]
Ex Ia IIC	0.2	0.1	0.05	0.02
	0.2	1	2.1	4.3
Ex Ia IIC	100	50	20	10
	100	5.4	7.3	0.2
Ex Ia IIC	3.6	5.4	7.3	0.3
	3.6	5.4	7.3	27.3
Ex Ia IIC	3.6	5.4	7.3	8.3
	3.6	5.4	7.3	27.3

The values of the table below are only applicable, if the internal inductance  $L_i$  (without the cable) or the internal capacitance  $C_i$  (without the cable) of the connected equipment is  $\leq 1\%$  of the below specified values.

If  $L_i$  (without the cable) and  $C_i$  (without the cable) of the connected equipment are  $> 1\%$  of the specified values, the specified values of  $L_e$  shall be reduced to 50 %.

The reduced capacitance of the external circuit (including cable) shall not exceed 1 µF for group IIC and 500 nF for group IIC.

Ex Ia	IIC	IIC
Maximum permissible external inductance	20 mH	63 mH
Maximum permissible external capacitance	36.3 µF	896.3 µF

For the temperature probes listed below, which have to be considered as simple apparatus and which are operated with the device, the limit value for the maximum permissible upper limit of the ambient temperature according to the temperature class resp. the maximum surface temperature has to be taken from the following table:

Temperature class resp. maximum surface temperature	Upper limit of the medium and ambient temperature for applications requiring devices of equipment protection level Ga resp. Da		Upper limit of the medium and ambient temperature for applications requiring devices of equipment protection level Gb	
	Temperature probes with Pt100	Temperature probes with thermocouples	Temperature probes with Pt100	Temperature probes with thermocouples
T1 / A45 °C	432.5 °C	439.1 °C	342.5 °C	349.1 °C
	282.5 °C	289.1 °C	222.5 °C	229.1 °C
T2 / 200 °C	187.5 °C	194.1 °C	147.5 °C	154.1 °C
	137.5 °C	144.1 °C	97.5 °C	104.1 °C
T3 / 100 °C	122.5 °C	129.1 °C	82.5 °C	89.1 °C
	72.5 °C	79.1 °C	32.5 °C	39.1 °C
T4 / 75 °C	87.5 °C	94.1 °C	67.5 °C	74.1 °C
	37.5 °C	44.1 °C	17.5 °C	24.1 °C
T5 / 50 °C	72.5 °C	79.1 °C	52.5 °C	59.1 °C
	22.5 °C	29.1 °C	7.5 °C	14.1 °C

The following temperature probes of the manufacturer with Pt100 resistor-type thermometer are intended to be operated with the device:

Type designation of the manufacturer	Replacement character xxx

This certificate may only be reproduced without any change, in whole or in part.

Any change or damage shall be covered by the TÜV NORD CERT GmbH.

## Schedule to EU-Type Examination Certificate No. TUV 11 ATEX 666139 X Issue 00

902006/65-228-1003-1-15-xxx-666/922	500, 710 and 1000
902006/65-228-1003-1-15-xxx-254/922	
902006/65-228-2003-1-15-xxx-666/922	
902006/65-228-2003-1-15-xxx-254/922	
902006/10-402-1003-1-9-xxx-104/922	100, 150 and 200
902006/10-402-2003-1-9-xxx-104/922	
902006/10-228-1003-1-9-xxx-104/922	250
902006/10-228-2003-1-9-xxx-104/922	
902006/10-228-2003-1-15-xxx-254/922	710
902006/54-227-1003-1-12-xxx-615/922	190
902006/54-227-2003-1-12-xxx-615/922	
902006/53-507-1003-1-12-xxx-615/922	100, 160, 190 and 220
902006/53-507-2003-1-12-xxx-615/922	
902006/53-505-1003-1-12-xxx-615/922	100, 160 and 220
902006/53-505-2003-1-12-xxx-615/922	
902006/40-228-1003-1-12-xxx-615/922	250
902006/10-390-1003-1-8-xxx-104/922	

The following temperature probes of the manufacturer with thermocouple are intended to be operated with the device:

Type designation of the manufacturer	Replacement character xxx
901006/65-547-2043-15-xxx-666/922	500, 710 and 1000
901006/65-546-2043-15-xxx-666/922	
901006/66-550-2043-6-xxx-666/922	250, 395 and 500
901006/66-880-1044-6-xxx-666/922	
901006/66-880-2044-6-xxx-666/922	
901006/66-853-1046-6-xxx-666/922	
901006/66-853-2046-6-xxx-666/922	
901006/54-544-2043-15-xxx-254/922	710
901006/54-544-1043-15-xxx-254/922	
901006/54-544-2043-15-xxx-254/922	
901006/54-544-1043-15-xxx-254/922	
901006/53-543-1042-12-xxx-615/922	220
901006/53-543-2042-12-xxx-615/922	
901006/45-551-2043-2-xxx-11-1000...20000/922	50...2000

## Thermal data:

Permissible ambient temperature range during operation:  $0^{\circ}\text{C} \leq T_a \leq +55^{\circ}\text{C}$

- (16) Drawings and documents are listed in the ATEX Assessment Report No. 20 203 261 400

- (17) Specific Conditions for Use:

For applications that require EPL, Ga or EPL Da devices, safety temperature limiter / safety temperature monitor must be used redundantly (HFT > 0).

Only for applications that require EPL, Ob or EPL Db devices, the safety temperature limiter / safety temperature monitor is used as single-channel (HFT = 0).

Schedule to EU-Type Examination Certificate No. TÜV 11 ATEX 656139 X Issue 00

This refers to equipment which does not provide an ignition source in fault-free operation, but has no fault tolerance with regard to ignition protection.

For alternative concepts / applications, the requirements / options according to EN ISO 80079-37 resp. EN 50485 have to be taken into account.

**(18) Essential Health and Safety Requirements:**

No additional ones.

- End of EU-Type Examination Certificate -

## 18.3 ATEX eurofins



### EU-Type Examination Certificate

- (1) **Equipment or protective system intended for use in potentially explosive atmospheres - Directive 2014/54/EU**  
 Certificate number: **SEV 17 ATEX 0161 X**
- (2) **Product**  
 Safety temperature limiter and safety temperature monitor JUMO SafetyM STB-STW Ex
- (3) **Manufacturer**  
 JUMO GmbH & Co. KG
- (4) **Address**  
 Markt-Juchheim-Strasse 1, 36039 Fulda, Germany
- (5) **The equipment and any acceptable variation thereof is specified in the schedule to this certificate and the documents therein referred to.**
- (6) **European Parliament and of the Council, dated 28 February 2014, certifies that the product has been found to comply with the essential health and safety requirements relating to the design and construction of products intended for use in potentially explosive atmospheres given in Annex II to the Directive. The examination and test results are recorded in confidential report no 21CH-00125-X02. Conformance with the essential health and safety requirements has been assumed by compliance with:**
- EN IEC 60074-2:2018  
 EN 60079-1:2014  
 EN 60079-2:2014  
 EN IEC 60079-7:2015/A1:2018  
 EN 60079-31:2014  
 EN ISO 60079-36:2018  
 EN ISO 60079-37:2018  
 EN 50495:2018

Entered in respect of those requirements listed at item 18 of the schedule.

- (10) If the sign 'X' is placed after the condition number, it indicates that the product is subjected to special conditions for safe use specified in the schedule to this certificate. The 'V' or 'W' after the certificate number, it indicates that this certificate must not be mistaken for a certificate granted for an equipment or protective system. This permit certificate may be used as a basis for certification of an equipment or protective system.

- (11) This EU type examination certificate relates only to design and construction of the specified product. Further requirements of this directive apply to the manufacturing process and supply of the product. These are not covered by this certificate.
- (12) The marking of the product shall include the following:



See (20) Markings

Eurofins Eurofins & Electrotech Product Testing AG

Notified Body ATEX



Patricia Clausen

Product Certification

7/14, 2017

Ferratorf, 2022-11-15

Issue: 1



Page 1 of 4

## Appendix

(14) EU-Type Examination Certificate no. SEV 17 ATEX 0161 X

- (15) **Description of product**  
 The ATEX category STB5TW Ex mentioned above are either a safety temperature limiter or a safety temperature monitor considered as associated safety temperature facilities intended for installation on mounting rails outside the hazardous areas.  
 Each output of the two output circuits of the device is provided to be connected to a resistor-type thermometer (PT100 or PT1000) or to a thermocouple or to measure a standardized signal current (4...20 mA). The output circuits are intended to be installed in areas with an explosive gas or dust category. And must be installed and protected in a suitable type of protection for the used category.

**Parameters:**

**For types STB5TW Ex 701155 / 7... .., ...., ...., ...., 23 / ...., ...**  
 Sluggly circuit only for the connection to a non-intrinsically safe circuit with a (Terminals N and L1) safety-related maximum voltage of  
 $U_n = 110$  up to 280 V AC +10% / -15%, 48 up to 63 Hz  
 $U_n = 250$  V

**For types STB5TW Ex 701155 / 7... .., ...., ...., ...., 23 / ...., ...**  
 Sluggly circuit only for the connection to a non-intrinsically safe circuit with a (Terminals L- and L+) safety-related maximum voltage of  
 $U_n = 20$  up to 50 V DC or AC, 48 up to 63 Hz  
 $U_n = 250$  V

**For all types**

Binary connection only for the connection to a non-intrinsically safe circuit with a (Terminals 4 and 5) safety-related maximum voltage of  
 $U_n = 250$  V

Analog connection only for the connection to a non-intrinsically safe circuit with a (Terminals 9 and 10) safety-related maximum voltage of  
 $U_n = 250$  V

Relay connection only for the connection to a non-intrinsically safe circuit with a (Terminals 11, 12, 13) safety-related maximum voltage and current of  
 $U_n = 250$  V  
 $I_n = 3$  A

Relay connection only for the connection to a non-intrinsically safe circuit with a (Terminals 14, 15, 16) safety-related maximum voltage and current of  
 $U_n = 250$  V  
 $I_n = 3$  A

USB connection only for the connection to a non-intrinsically safe circuit with a (05B socket) safety-related maximum voltage of  
 $U_n = 250$  V



Output circuit in type of protection for increased safety (Ex-eb) (IC resp. IIC with the Terminals 1, 2, 3 and 6, 7, 8) following maximum values per circuit:

U<sub>0</sub> = 6 V  
 I<sub>n</sub> = 612 mA  
 P<sub>n</sub> = 612 mW  
 Characteristic line: linear

Classification of installation and use ..... : Stationary

Ingress protection ..... : IP20

Rated ambient temperature range (°C) ..... : 0 °C ... +55 °C

Rated service temperature range (°C) for Ex-Components ... : --

(16) Report number

21CH-00123.X02

(17) Specific conditions of use

- Switching operations may be performed on the electrical circuits (Ex-eb) only when the JUMO safetyM STB/STW Ex, including all supply lines, is de-energized.
- Only the STB (safety temperature limiter) variant of the JUMO safetyM STB/STW Ex is admissible for use as a safety device for medium overpressure monitoring with static pressurized enclosures.
- The safety-relevant settings of the JUMO safetyM STB/STW Ex must be protected against unauthorized changes (e.g. with sealed or password-protected inputs).
- For use of the JUMO safetyM STB/STW Ex in the STW (safety temperature monitor) variant, it must be ensured that after a switch-off by the temperature limiter an automatic restart of the monitored equipment is prevented by a higher-level control system.
- If the JUMO safetyM STB/STW Ex is used in the single-channel device variant to monitor non-medical system sources and a warning is issued on demand, the user must take immediate measures to achieve a safe status.
- If it is installed in a separate electrical cabinet, the following warning must be attached to the outside of this electrical cabinet: **WARNING: "Caution - This enclosure contains equipment that is part of an ignition protection system according to ISO 80079-27."**

(18) Essential health and safety requirements

In addition to the essential health and safety requirements (EHSSRs) covered by the standards listed at item 9, the following are considered relevant to this product, and conformity is demonstrated in the report:

Clause Note	Subject
----------------	---------

(19) Drawings and Documents

See test report "Manufacturer's Documents"



(20) Multiple

- II (2) G [Ex eb Gd] MC resp.  II (2) G [Ex eb Gd] MC  
 II (2) D [Ex eb Dd] IIC  
 II (2) G [Ex h Gd] IIC  
 II (2) D [Ex h Dd] IIC



## 18.4 IECEx TÜV Nord

		<b>IECEx Certificate of Conformity</b>	
<b>INTERNATIONAL ELECTROTECHNICAL COMMISSION</b> IEC Certification System for Explosive Atmospheres <small>For rules and details of the IECEx Scheme visit <a href="http://www.iecex.com">www.iecex.com</a></small>			
Certificate No.:	<b>IECEx TUN 15 8926X</b>	Page 1 of 4	Certificate status:
Status:	<b>Current</b>	Issue No. 2	Issue 1 (EN1717-04-20) Issue 2 (EN1717-04-15)
Date of Issue:	<b>2023-06-07</b>		
Applicant:	<b>ZUMO GmbH &amp; Co. KG</b> ZUMO Industrietechnik GmbH 38030 Fuldapark 1 Germany		
Equipment:	<b>ZUMO safetyM STRISTM type 79155S / - - - - - 231 - - - - - and type 79155S / - - - - - 251 - - - - -</b>		
Original accessory:			
Type of Protection:	<b>Intrinsic Safety "i"</b> Non electrical type of protection control of ignition source "A"		
Marking:	<b>[Ex ia Daj] IC ec</b> <b>[Ex ia Daj] IC ec</b> <b>[Ex ia Daj] IC ec</b> <b>[Ex ia Daj] IC ec</b>		
Approved by Issue on behalf of the IECEx Certification Body:	<b>Thomas Heinen</b>	Deployment Head of IECEx Certification Body:	<b>TÜV NORD</b> Digital certificate Number: 20230247 152846-40789
Signature: (for printed version)			
Date: (for printed version)			
<p>1. This certificate and its details may only be reproduced with the written consent of TÜV NORD CERT GmbH.</p> <p>2. The certificate is not transferable and is the property of the issuing body.</p> <p>3. The validity and authenticity of the certificate may be verified by visiting <a href="http://www.iecex.com">www.iecex.com</a> or via the QR Code.</p>			
<p>Certificate issued by:</p> <p><b>TÜV NORD CERT GmbH</b> Maximilianstrasse 1 42699 Solingen Germany</p>			
			



## IECEX Certificate of Conformity

Certificate No: **IECEX TUN 15 003X**

Page 2 of 4

Date of issue: **2023-06-07**

Issue No: 2

Manufacturer: **AKMO GEMH & Co. KG**  
Munich-Jacobshorn-Strasse 1  
30039 Fulda  
Germany

Manufacturing  
location:

This certificate is based on verification that a sample(s), representative of production, was assessed and tested and found to comply with the IEC Standard set below and that the manufacturer's quality system, relating to the Ex products covered by this certificate, was assessed and found to comply with the IECEx Quality system requirements. This certificate is granted subject to the conditions as set out in IECEx Scheme Rules, IECEx 02 and Operational Documents as amended.

#### STANDARDS

The equipment and any acceptable variations to it specified in the schedule of this certificate and the detailed documents, was found to comply with the following standards:

**IEC 60079-0:2017** Explosive atmospheres - Part 0: Equipment - General requirements  
Edition: 7.0

**IEC 60079-11:2011** Explosive atmospheres - Part 11: Equipment protection by intrinsic safety "i"  
Edition: 6.0

**ISO 9001:2015:2016** Explosive atmospheres - Part 36: Non-electrical equipment for explosive atmospheres - Basic methods and requirements  
Edition: 1.0

**ISO 9001:2015:2016** Explosive atmospheres - Part 37: Non-electrical equipment for explosive atmospheres - Non electrical type of production contributory safety "C": control of gasket source "C": liquid immersion "X"  
Edition: 1.0

This Certificate **does not** indicate compliance with safety and performance requirements other than those expressly included in the Standards listed above.

#### TEST & ASSESSMENT REPORTS:

A sample(s) of the equipment listed has successfully met the examination and test requirements as recorded in:

Test Reports:

DE/TUNE/FR/6:0025/01

DE/TUNE/FR/6:0025/02

Quality Assessment Report:

DE/EP/CA/23:0003/00





## IECEx Certificate of Conformity

Certificate No.: **IECEx TUN 15.0038X**

Date of issue: **2023-06-07**

Page 4 of 4

Issue No: 2

**DETAILS OF CERTIFICATE CHANGES (for Issues 1 and above)**  
The CQR No. DE/TUN/CQR/13.0005 has been replaced by DE/CER/CQR/ 23.0003

**Annex:**

[Attachment to IECEx TUN 15.0038 Issue No. 2.pdf](#)



**Electrical data:**

**FACTORY SET POINTS 701196 / 1 - 200 V AC, 20 J max.**

Supply circuit  
(Terminals N and L1)

only for the connection to a non-retroactively safe circuit with  
a safety-related maximum voltage of:

$U_{s0}$  = 110 up to 240 V a.c. +15% / -15%, 48 up to 63 Hz

$U_{s0}$  = 250 V

**FACTORY SET POINTS 701196 / 2 - 200 V AC, 20 J max.**

Supply circuit  
(Terminals L<sub>1</sub> and L<sub>2</sub>)

only for the connection to a non-retroactively safe circuit with  
a safety-related maximum voltage of:

$U_{s0}$  = 20 up to 20 V d.c. or a.c., 48 up to 63 Hz

$U_{s0}$  = 250 V

**For all tests:**

Drainy connection  
(Terminals 4 and 5)

only for the connection to a non-retroactively safe circuit with  
a safety-related maximum voltage of:

$U_{s0}$  = 250 V

only for the connection to a non-retroactively safe circuit with  
a safety-related maximum voltage of:

$U_{s0}$  = 250 V

Relay connection  
(Terminals 11, 12, 13)

only for the connection to a non-retroactively safe circuit with  
a safety-related maximum voltage and current of:

$U_{s0}$  = 250 V

$I_{s0}$  = 3 A

Relay connection  
(Terminals 14, 15, 16)

only for the connection to a non-retroactively safe circuit with  
a safety-related maximum voltage and current of:

$U_{s0}$  = 250 V

$I_{s0}$  = 3 A

USB connection  
(USB socket)

only for the connection to a non-retroactively safe circuit with  
a safety-related maximum voltage and current of:

$U_{s0}$  = 250 V

Output circuit  
(Terminals 1, 2, 3 and 6, 7, 8)

in type of protection retenc safety Ex ia IIC resp. Ex ia IIC  
with the following maximum values per circuit:

$U_{s0}$  = 6 V

$I_{s0}$  = 41.2 mA

$P_{s0}$  = 81.8 mW

Characteristic time: linear

The effective external capacitance  $C_{s0}$  is 7 µF

The effective external inductance  $L_{s0}$  is negligibly small

The maximum permissible values for the external inductance  $L_{s0}$  and the external capacitance  $C_{s0}$  have to  
be taken from the following table:

TUV NORD CERT GmbH  
Hannover Office  
Am TÜV 1  
30619 Hannover  
Germany



Page 3 of 6  
Attachment to IECEx TLUH 15.0036X Issue No.: 2

Ex II IIC	$L_n$ [mH]	0.2	0.1	0.05	0.02	0.01	0.001
	$C_n$ [ $\mu$ F]	0.2	1	2.1	4.3	7.3	36.3
Ex II IIC	$L_n$ [mH]	100	50	20	10	0.2	0.001
	$C_n$ [ $\mu$ F]	3.8	5.4	7.3	8.3	27.3	198.3

The values of the table below are only applicable, if the external inductance  $L_n$  (without the cable) or the internal capacitance  $C_n$  (without the cable) of the connected equipment is  $\leq 1\%$  of the values specified.

If  $L_n$  (without the cable) and  $C_n$  (without the cable) of the connected equipment are  $> 1\%$  of the specified values, the specified values of  $L_n$  shall be reduced to 50 %.

The reduced capacitance of the external circuit (including cable) shall not exceed 1  $\mu$ F for group IIC and 600 pF for group IIC.

Ex II	Maximum permissible external inductance	IIC	20 mH	IIC	03 mH
	Maximum permissible external capacitance		36.3 $\mu$ F		696.3 $\mu$ F

For the temperature grades listed below, which have to be considered as single apparatus and which to be operated with the device, the first value for the maximum permissible upper limit of the ambient temperature according to the temperature class resp. the maximum surface temperature has to be taken from the following table:

Temperature class and resp. maximum surface temperature	Upper limit of the medium and ambient temperature for applications requiring devices of equipment protection level (OL) nE90, O0		Upper limit of the medium and ambient temperature for applications requiring devices of equipment protection level (OL) nE90, O0	
	Temperature grades with PT100	Temperature grades with thermocouple	Temperature grades with PT100	Temperature grades with thermocouple
T1/445 °C	432.5 °C	438.1 °C	347.5 °C	349.1 °C
T2/285 °C	282.5 °C	289.1 °C	222.5 °C	229.1 °C
T3/195 °C	187.5 °C	194.1 °C	147.5 °C	154.1 °C
T4/130 °C	127.5 °C	129.1 °C	97.5 °C	107.1 °C
T5/85 °C	87.5 °C	94.1 °C	47.5 °C	54.1 °C
T6/50 °C	72.5 °C	79.1 °C	59.5 °C	62.1 °C

The following temperature probes of the manufacturer with PT100 resistor-type thermometer are intended to be operated with the device:

Type designation of the manufacturer	Replacement character xxx
90200665-228-1003-1-15-xxx-8159/22	500, 710 and 1100
90200665-228-1003-1-15-xxx-2549/22	
90200665-228-2003-1-15-xxx-8159/22	
90200665-228-2003-1-15-xxx-2549/22	
902006110-402-1003-1-9-xxx-1049/22	150, 150 and 200
902006110-402-2003-1-9-xxx-1049/22	250
902006070-228-1003-1-8-xxx-1049/22	250
902006070-228-2003-1-8-xxx-1049/22	
90200664-227-1003-1-15-xxx-2549/22	710
90200664-227-2003-1-15-xxx-2549/22	
90200665-505-2003-1-12-xxx-8159/22	150
90200665-505-1003-1-12-xxx-8159/22	
90200665-502-2003-1-12-xxx-8159/22	150, 160, 180 and 220
90200665-502-1003-1-12-xxx-8159/22	150, 160 and 220
90200665-505-3003-1-12-xxx-8159/22	
90200648-228-1003-1-12-xxx-8159/22	
902006110-390-1003-1-8-xxx-1049/22	250

The following temperature probes of the manufacturer with thermocouple are intended to be operated with the device:

Type designation of the manufacturer	Replacement character xxx
901006065-547-2043-15-xxx-8159/22	500, 710 and 1100
901006065-546-2043-15-xxx-8159/22	
901006070-540-3043-8-xxx-6030/22	250, 265 and 500
901006070-800-1044-8-xxx-6030/22	
901006070-800-2044-8-xxx-6030/22	
901006070-803-1046-8-xxx-6030/22	
901006070-803-2046-8-xxx-6030/22	
901006054-544-1043-15-xxx-2549/22	710
901006054-544-2043-15-xxx-2549/22	
901006054-544-3043-15-xxx-2549/22	
901006054-544-1043-15-xxx-2549/22	220
901006054-543-2043-15-xxx-2549/22	
901006042-551-2043-2-xxx-11-1000-2000/09/22	50 ... 2000

**Thermal data:**

Permissible ambient temperature range during operation: 0 °C ≤ T<sub>amb</sub> ≤ 45 °C

TÜV NORD CERT GmbH  
Hannover Office  
Am TÜV 1  
30519 Hannover  
Germany



Page 5 of 6  
Attachment to IECEx TUN 15.0036X issue No.: 2

**Specific Conditions of Use:**

For applications that require EPL, Ga or EPL, Da devices, the safety temperature limiter / safety temperature monitor must be used redundantly (SFT = 0).

Only for applications that require EPL, Gb or EPL, Cb devices, the safety temperature limiter / safety

temperature monitor is used as single-channel (SFT = 0).

This refers to equipment which does not provide an ignition source in trouble-free operation, but has no fault tolerance with regard to ignition protection.

For alternative concepts / applications, the requirements / options according to ISO 90079-5/7 have to be taken into account.



## IECEx Certificate of Conformity

INTERNATIONAL ELECTROTECHNICAL COMMISSION  
IEC Certification System for Explosive Atmospheres

For rules and details of the IECEx System visit [www.iecex.com](http://www.iecex.com)

Certificate No.: IECEx BRV 22 041HX

Page 1 of 5

Certificate valid until:

Status: Current

Issue No.: 1

Issue 0 (2022-11-18)

Date of Issue: 2023-04-27

Applicant: JUMO GmbH & Co. KG  
Maximilianstrasse 1  
36039 Fulda  
Germany

Equipment: Safety Temperature limiter and safety temperature monitor JUMO SafetyM 8TBS17W Ex

Optional accessories: -

Type of Protection: "r", "s", "t", "T"

Marking: Ex e (D) IC rev, Ex d (D) IC

Ex s (D) IC

Ex t (D) IC

Ex s (D) IC

Ex s (D) IC

Approved for issue on behalf of the IECEx  
Certification Body

Thomas Klotzinger

Signature:

Manager Product Certification

Date: 2023-04-27  
(for printed version)

1. This certificate and its details apply only to the equipment listed.
2. The certificate is not transferrable and remains the property of the issuing body.
3. The status and authenticity of this certificate may be verified by visiting [www.iecex.com](http://www.iecex.com) or via the QR Code.



Certificate issued by:

European Electrical & Electronic Product Testing AG

Stalderstrasse 3

8320 Pfundschulden

Switzerland



EKE





## IECEx Certificate of Conformity

Certificate No.: IECEx SVZ 22 061X  
Date of issue: 2023-04-27

Page 2 of 5  
Serial No.: 1

Manufacturer: **AVIMO GmbH & Co. KG**  
Mertig-Adelheim-Strasse 1  
36029 Fulda  
Germany

Manufacturing  
location:

This certificate is issued as verification that a sample(s), representative of production, was assessed and found to conform to the IEC Standard set below and that the manufacturer's quality system, relating to the Ex products covered by this certificate, was assessed and found to comply with the IECEx Quality system requirements. This certificate is granted subject to the conditions set out in IECEx Scheme Rules, IECEx ID and Operational Documents as amended.

#### STANDARDS

The equipment and any acceptable variations to it specified in the schedule of this certificate and the identified documents, was found to comply with the following standards:

- IEC 60079-0:2017 Explosive atmospheres - Part 0: Equipment - General requirements Edition 1: 2
- IEC 60079-1:2014-08 Explosive atmospheres - Part 1: Equipment protection by flameproof enclosures "d" Edition 2: 0
- IEC 60079-3:2013 Explosive atmospheres - Part 3: Equipment dust ignition protection by enclosure "t" Edition 2
- IEC 60079-7:2017 Explosive atmospheres - Part 7: Equipment protection by increased safety "e" Edition 1
- ISO 60079-36:2016 Explosive atmospheres - Part 36: Non-electrical equipment for explosive atmospheres - Safety methods and Edition 1: 0
- ISO 60079-7:2016 Explosive atmospheres - Part 37: Non-electrical equipment for explosive atmospheres - Non-renewable type of production construction safety "c"; covered of gipsen boards "V"; liquid immersion "V" Edition 1: 0

This Certificate does not indicate compliance with safety and performance requirements other than those expressly included in the Standards listed above.

#### TEST & ASSESSMENT REPORTS:

A sample(s) of the equipment listed has successfully met the examination and test requirements as recorded in:

Test Report:

CVS/IECEx/0522/001700

Quality Assessment Report:

QCE/PS/QAD03 000300



## IECEx Certificate of Conformity

Certificate No.: IECEx BEV 22 01HX  
Date of issue: 2023-04-27

Page 3 of 5  
Issue No: 1

### EQUIPMENT

Equipment and systems covered by this Certificate are as follows:

#### General product information:

The A200 safety/STB/STW Ex mentioned above are either a safety temperature limiter or a safety temperature monitor considered as a safety temperature limiter. The A200 safety/STB/STW Ex is intended for use in hazardous areas. Each output of the safety circuit of the device is provided for use either to switch the electrical power (PT100 or PT1000) or to a thermocouple or to measure a standardized signal current (4...20 mA). The output circuits are intended to be operated in series with an explosive gas or dust atmosphere. And must be installed and protected in a suitable type of protection for the stated category.

#### Parameters:

**For Types STB/STW Ex, T0115E, I<sup>2</sup> = 100 mA, U<sub>max</sub> = 231 V<sub>AC</sub>, max  
Safety circuit (N and L) includes: contact rated current with safety  
UL<sub>sc</sub> = 150 up to 240 V<sub>AC</sub>, +10%, I<sub>sc</sub> = 10%, 48 up to 63 Hz  
UL<sub>sc</sub> = 250 V**

**For Types STB/STW Ex, T0115E, I<sup>2</sup> = 100 mA, U<sub>max</sub> = 231 V<sub>AC</sub>, max  
Safety circuit only for the connection to a non-externally safe circuit with a  
thermocouple (L and L1) safety-rated maximum voltage of  
UL<sub>sc</sub> = 20 up to 30 V<sub>DC</sub> or AC, 48 up to 63 Hz  
UL<sub>sc</sub> = 250 V**

#### SPECIFIC CONDITIONS OF USE: YES as shown below:

- Switching operations may be performed on the electrical circuit (Ex-nd) only when the A200 safety/STB/STW Ex, including all supply lines, is de-energized.
- Only the STW (safety temperature limiter) variant of the A200 safety/STB/STW Ex is admissible for use in a safety device for explosion overpressure monitoring with static, pressurized enclosure.
- The safety-related settings of the A200 safety/STB/STW Ex must be protected against unauthorized changes (e.g. with sealed or password-protected inputs).
- For use of the A200 safety/STB/STW Ex in the STW (safety temperature monitor) variant, it must be ensured that after a switch-off by the temperature limiter an automatic restart of the monitored equipment is prevented by a higher-level control system.
- If the A200 safety/STB/STW Ex is used in the single-channel device variant to monitor non-electrical system sources and a warning is issued on detection, the user must take immediate measures to activate a safe status.
- If a fault is indicated in a separate electrical cabinet, the following warning must be attached to the outside of the electrical cabinet: WARNING: "Caution - This enclosure contains equipment that is part of an explosion protection system according to IEC 60079-37."





## IECEx Certificate of Conformity

Certificate No.: **IECEx SER 23 0618X**  
 Date of issue: **2023-04-27**

Page 4 of 5  
 Issue No: 1

**Equipment (s):**

**For all types**  
 Binary connection only for the connection to a non-intrinsically safe circuit with a (Terminals 4 and 5) safety-related maximum voltage of  $U_{m} = 250\text{ V}$

Analogue connection only for the connection to a non-intrinsically safe circuit with a (Terminals 9 and 10) safety-related maximum voltage of  $U_{m} = 250\text{ V}$

Binary connection only for the connection to a non-intrinsically safe circuit with a (Terminals 11, 12, 13) safety-related maximum voltage and current of  $I_{m} = 250\text{ V}$

$I_{m} = 3\text{ A}$

Binary connection only for the connection to a non-intrinsically safe circuit with a (Terminals 14, 15, 16) safety-related maximum voltage and current of  $I_{m} = 250\text{ V}$

$I_{m} = 3\text{ A}$

USB connection only for the connection to a non-intrinsically safe circuit with a (USB socket) safety-related maximum voltage of  $U_{m} = 250\text{ V}$

Output circuit in type of protection for increased safety (Ex-ell) (IC resp. IIC) with the (Terminals 1, 2, 3 and 6, 7, 8) following maximum values

$I_{m} = 1\text{ V}$

$I_{m} = 0.12\text{ mA}$

$P_{m} = 0.13\text{ mW}$

Characteristics (see Annex

Classification of explosion and use: **Stainless**

Ingress protection: **IP70**

Rated ambient temperature range (°C): **0 °C ... +55 °C**

Rated service temperature range (°C) for Ex-Components: **—**





## IECEx Certificate of Conformity

Certificate No.: IECEx REV 22 0019X  
Date of issue: 2023-04-27

Page 3 of 5  
Issue No: 1

**DETAILS OF CERTIFICATE CHANGES (for Issues 1 and above)**  
Change or EICCB for quality system. Link to OHS updated.



## 18.6 EU declaration of conformity

 <b>MORE THAN SENSORS AND AUTOMATION</b>		<b>JUMO GmbH &amp; Co. KG</b> Markt-Juchheim-Strasse 1 36039 Fulda, Germany		Tel: +49 671 9033-0 Fax: +49 671 9033-500 E-Mail: <a href="mailto:info@jumo.de">info@jumo.de</a> Internet: <a href="http://www.jumo.de">www.jumo.de</a>	
<h2>EU-Konformitätserklärung</h2> <p>EU declaration of conformity / Declaration UE de conformité</p>					
<b>Dokument-Nr.</b>	CE 720	<b>Hersteller</b>	JUMO GmbH & Co. KG	<b>Produkt</b>	
<b>Hersteller</b>		<b>Hersteller / Manufacturer / Fabricant</b>	JUMO GmbH & Co. KG	<b>Produkt / Product</b>	
<b>Anschrift</b>		<b>Adresse / Address</b>	Markt-Juchheim-Strasse 1, 36039 Fulda, Germany	<b>Name</b>	
<b>Adresse / Address</b>				<b>Name / Nom</b>	
				<b>Typ</b>	
				<b>Typ / Type</b>	
				<b>Typen-Nr.</b>	
				<b>Data sheet no. / Nr.</b>	
				<b>Document</b>	
				<b>référence</b>	
				<b>701155</b>	
				<b>701155</b>	
<b>Produktbeschreibung</b> Product description / Description du produit Elektronischer Sicherheitstemperturbegrenzer/-schalter nach DIN EN 14597 und ATEX-Zulassung					
<b>Wir erklären in alleiniger Verantwortung, dass das bezeichnete Produkt die Anforderungen der Europäischen Richtlinien erfüllt.</b> We hereby declare in sole responsibility that the designated product fulfils the requirements of the European Directives listed below and that we are responsible for its product being in Conformity with the European Directives.					
<b>Dokument-Nr.</b>	CE 720	<b>EU-Konformitätsanforderung</b>			<b>Seite 1 von 7</b>
<b>Dokument-Nr. / Document n°</b>					

**JUMO GmbH & Co. KG**  
Müller-Weidenhillerstraße 1  
36209 Fulda, Germany

Tel. +49 (0) 3051-8  
Fax. +49 (0) 3051-550

E-Mail: [info@jumo.de](mailto:info@jumo.de)  
Internet: [www.jumo.de](http://www.jumo.de)



**MORE THAN SENSORS  
AND AUTOMATION**

## 1. Richtlinie

Directive / Directive

EMC 2014/53/EU

Name

Name / Nom

Konformitätsbewertungsverfahren

Mod. A

Conformity assessment procedure /

Procédure d'évaluation de la conformité

Datum der Erstarthung des CE-Zeichens auf dem Produkt

Date of first application of the CE mark to the product /

Date de l'ère application du signe sur le produit

## Angewendete Normen/Spezifikationen

Standard/Specifications applied / Normes/Spécifications appliquées

Referenz	Ausgabe	Bemerkung
Reference / Référence	Edition / Édition	Comment / Remarque
EN 61320-1	2013	
EN 60730-1	2011	
EN 60730-2-9	2010	
EN 60730-1	2019+A1:2019	
EN 60730-2-9	2019+A1:2019+A2:2020	

## Gültig für Typ

Valid for Type / Valable pour le type

701155/...

## 2. Richtlinie

Directive / Directive

ATEX 2014/54/EU

Name

Name / Nom

Konformitätsbewertungsverfahren

Mod. B-D

Conformity assessment procedure /

Procédure d'évaluation de la conformité

Datum der Erstarthung des CE-Zeichens auf dem Produkt

Date of first application of the CE mark to the product /

Date de l'ère application du signe sur le produit

Document No. / Document n°

CE 720

EU-Konformitätsbewertung

Seite 2 von 7

**JUMO GmbH & Co. KG**  
 JUMO-Industrie-Strasse 1  
 38207 Wolfen, Germany

Tel. +49 535 9214  
 Fax. +49 535 923380

E-Mail: [info@jumo.de](mailto:info@jumo.de)  
[www.jumo.de](http://www.jumo.de)



**MORE THAN SENSORS  
 AND AUTOMATION**

#### Qualif für Typ

Valid for Type / Valable pour le type

701155\*\*\*\*\*044...  
 701155\*\*\*\*\*045...

#### 2.1 EU-Baumusterprüfbescheinigung

EU type examination certificate / Certificat d'examen de type UE

##### Zertifikatsnummer

TÜV 11 ATEX 596139 X

Certificate number / Numéro de certificat

##### Notizierte Stelle

Notified Body / Organisme notifié

TÜV NORD CERT GmbH, Langenwallstraße  
 20, 45141 Essen, Germany

#### Angewendete Normen/Spezifikationen

Standards/Specifications applied / Normes/Spécifications appliquées

Referenz / Référence	Ausgabe / Édition	Bemerkung / Remarque
EN 60079-0	2018	
EN 60079-11	2012	
EN 60079-36	2016	
EN 60079-37	2016	
EN 50485	2010	

#### Qualif für Typ

Valid for Type / Valable pour le type

701155\*\*\*\*\*044...

#### 2.2 EU-Baumusterprüfbescheinigung

EU type examination certificate / Certificat d'examen de type UE

##### Zertifikatsnummer

SEV 17 ATEX 0161 X

Certificate number / Numéro de certificat

##### Notifizierte Stelle

Notified Body / Organisme notifié

Europa Electric & Electronic Product Testing  
 A.G. Luppingerstrasse 3, 8200 Fehraltorf,  
 Switzerland

Document-Nr.  
 Document No. / Document n°

CE 720

EU-Konformitätsbescheinigung

Seite 3 von 7

JUMO GmbH & Co. KG

Moltis-Customer-Service 1 Tel. +49 (0) 800 800124 E-Mail: [info@jumo.com](mailto:info@jumo.com)  
202017-004 Germany Fax: +49 (0) 800 8001200 Internet: [www.jumo.com](http://www.jumo.com)



MORE THAN SENSORS  
AND AUTOMATION

#### Angewendete Normen/Spezifikationen

Standards/Specifications applied / Normes/Spécifications appliquées

Referenz	Ausgabe	Bemerkung
Reference / Référence	Edition / Édition	Comment / Remarque
EN 60079-0	2018	
EN 60079-1	2014	
EN 60079-7	2015+A1 2018	
EN 60079-31	2014	
EN 60079-36	2016	
EN 60079-37	2016	
EN 50495	2010	

#### Qualif. Nr. Typ

Valid for Type / Valable pour le type  
701155-\*\*\*\*\*Q45-...

#### Qualitätsicherung bezogen auf den Produktionsprozess

Quality assurance of the production process / L'assurance de la qualité de la production

##### Zertifizierungsnummer

Available on request

Certificate number / Numéro de certificat

##### Notifizierendes Staat

BUREAU VERITAS Consumer Products  
Services Germany GmbH, Wilhelm-Herrmann-  
Straße 8, 19061 Schwerin, Germany  
2004

Notified body / Organisme notifié

##### Kennnummer

Identification no. / N° d'identification

### 3. Rechte

Directive / Directive

Name

MD 2006/42/EG

Name / Nom

Konformitätsbewertungsverfahren

Mod. A

Conformity assessment procedure /

Procédure d'évaluation de la conformité

Datum der Ersterkundung des CE-Zeichens auf 2012

dem Produkt

Date of first application of the CE mark to the product /

Date de première application du signe sur le produit

Document No.  
Document No. / Document #

CE 720

EU-Konformitätsbewertung

Seite 4 von 7

JUMO GmbH & Co. KG  
 Markt- und Service-Struktur 1  
 98527 Friesen, Germany

Telefon +49 (0)37 5051-1  
 Telefax +49 (0)37 5022-200

E-Mail [info@jumo.de](mailto:info@jumo.de)  
[www.jumo.de](http://www.jumo.de)



MORE THAN SENSORS  
 AND AUTOMATION

#### Angewendete Normen/Spezifikationen

Standards/Specifications applied / Normes/Spécifications appliquées

Referenz / Reference	Ausgabe / Edition	Bemerkung / Remarque
EN 13849-1	2015	
EN 60204-1	2018	

#### Gültig für Typ

Valid for Type / Valable pour le type  
 701155-\*\*\*\*\*059

#### 4. Rotorblätter

Director / Directeur

RoHS 2011/65/EU

Name

Name / Nom

Konformitätsbewertungsverfahren

Conformity assessment procedure /

Procédure d'évaluation de la conformité

Mod. A

Datum der Erstanforderung des CE-Zeichens auf 2017

dem Produkt

Date of first application of the CE mark to the product /

Date de 1<sup>ère</sup> application de signe sur le produit

#### Angewendete Normen/Spezifikationen

Standards/Specifications applied / Normes/Spécifications appliquées

Referenz / Reference	Ausgabe / Edition	Bemerkung / Remarque
VDA Umweltspezifische Aspekte bei der Produktentwicklung und -gestaltung	V1	

VDA Umweltspezifische Aspekte bei der Produktentwicklung und -gestaltung

Bemerkung / Remarque

#### Gültig für Typ

Valid for Type / Valable pour le type  
 701155-...

Dokument-Nr.  
 Document No. / Document #

CE 726

EU-Zulassungsbescheinigung

Seite 5 von 7

JUMO GmbH & Co. KG  
Moltis-Juchacz, Straße 1  
20229 Finken, Germany

E-Mail: [info@jumo.de](mailto:info@jumo.de)  
Internet: [www.jumo.de](http://www.jumo.de)



MORE THAN SENSORS  
AND AUTOMATION

#### 5. Richtlinien

Director / Directeur

LVD 2014/26/EU

Name

Name / Nom

Mod. A

Konformitätsbewertungsverfahren

Conformity assessment procedure /

Procédure d'évaluation de la conformité

Datum der Ersterhebung des CE-Zeichens auf 2012

dem Produkt

Date of first application of the CE mark to the product /

Date de 1<sup>ère</sup> application de l'âge sur le produit

#### Angewendete Normen/Spezifikationen

Standard/Specifications applied / Normes/Spécifications appliquées

Referenz	Ausgabe	Bemerkung
Reference / Référence	Edition / Édition	Comment / Remarque
EN 60730-1	2011	
EN 60730-2-9	2010	
EN 60730-1	2016+A1:2019	
EN 60730-2-9	2019+A1:2019+A2:2020	

#### Quang für Typ

Valid for Type / Valable pour le type  
701155/...

#### Allgemeine Bemerkungen

General remarks / Observations générales

LVD not applicable for type 701155/\*\*\*\*\*7099

**JUMO GmbH & Co. KG**  
 Hauptverwaltung 1  
 98520 Fulda, Germany

Tel: +49 691 8023-0  
 Fax: +49 691 8023-500

E-Mail: [info@jumo.de](mailto:info@jumo.de)  
 Internet: [www.jumo.de](http://www.jumo.de)



**MORE THAN SENSORS  
 AND AUTOMATION**

**JUMO GmbH & Co. KG**

Fulda, 2005-05-06

**Aussteller**  
 Issued by / Emitted par  
**OK, Datum**  
 Name oder / Nom. oder  
**Rechtsverbindliche Unterschriften**  
 (Legal) binding signatures /  
 Signatures juridiques valides

Berechnung Globale Vertrieb  
 i. V. Siedl Daxner

Leiter Managementsysteme  
 i. V. Matthias Raab

*M.R.*  
*Matthias Raab*

**Dokument Nr.**  
 Document No. / Document #

**CE 720**

**EU-Konformitätserklärung**

**Seite 7 von 7**







UK - Type Examination Certificate EPR5 ZT UKEX 1 497 X

Revision 0

(16) Reference Number: ZT1W0202

(17) Special conditions for AME LMR

- Switching operations may be performed on the electrical circuit (EX 40) only when the J2000 safety/STB/STW Ex, including all supply lines, is de-energized.
- Only the STB (safety temperature breaker) variant of the J2000 safety/STB/STW Ex is admissible for use as a safety device for minimum overpressure monitoring with static pressurized enclosures.
- The safety-related settings of the J2000 safety/STB/STW Ex must be protected against unauthorized changes (e.g. with sealed or password-protected inputs).
- For use of the J2000 safety/STB/STW Ex in the STW (safety temperature monitor) variant, it must be equipped at the start of a service/operation with a temperature limiter on automatic reset of the monitored equipment in order to prevent a further increase in temperature.
- The J2000 safety/STB/STW Ex is used in the high-charge device variant to monitor non-electrical system sources and a warning is issued on demand. The user must take protective measures to achieve a safe status. Ambient temperature range: 0 °C to +45 °C

(18) Essential health and safety instructions:

Not to be connected with alternating.

Certification International - explosion protection

Wormington, VA-13-2022



Certification International and its staff are not liable for any damage or liability to be sustained only if our certified, licensed or authorized users are authorized to perform, install, maintain, repair, modify, or use the equipment or system. This equipment is intended to be installed only if our certified, licensed or authorized users are authorized to perform, install, maintain, repair, modify, or use the equipment or system.

Certification (Explosion Protection) GmbH, EPR5 ZT1W0202 1 497 X, Revision 0

Address: Wormington, Virginia, USA, 22091-1302

Phone: +1 540 361 9100

www.certification-international.com

cert@certification-international.com

Approved Under the European Directive  
2014/52/EU, ATEX 153

Approved in Europe's main  
Certification Center (Germany)











#### UK - Type Examination Certificate EPR 22 UNEX 2 188 X

Revision 0

The values of the table below are only applicable if the internal inductance  $L_i$  (without the cable) or the internal capacitance  $C_i$  (without the cable) of the connected equipment is  $\leq 1\%$  of the value specified unless  $L_i$  (without the cable) and  $C_i$  (without the cable) of the connected equipment are  $> 1\%$  of the specified values. The specified values of  $L_i$  shall be reduced to 50 %; The reduced capacitance of the external circuit (including cable) shall not exceed 1  $\mu\text{F}$  for group IBC and 001 of for group IC.

Ex. nr	BC	IC
Maximum permissible external inductance	20 nH	83 nH
Maximum permissible external capacitance	36.3 $\mu\text{F}$	990.3 $\mu\text{F}$

For the temperature points listed below, which have to be considered as single apparatus and which is to be operated with the device, the test value for the maximum permissible upper limit of the ambient temperature according to the manufacturer (data sheet), the maximum surface temperature has to be taken from the following table.

Temperature class Temp. maximum surface temperature	Upper limit of the medium and ambient temperature for applications requiring devices of equipment protection level Da resp. Db		Upper limit of the medium and ambient temperature for applications requiring devices of equipment protection level Da resp. Ds	
	Temperature points with PT100	Temperature points with thermocouple	Temperature points with PT100	Temperature points with thermocouple
T1 / 440 °C	432.5 °C	439.1 °C	342.5 °C	348.1 °C
T2 / 260 °C	262.5 °C	269.1 °C	222.5 °C	228.1 °C
T3 / 160 °C	167.5 °C	174.1 °C	147.5 °C	154.1 °C
T4 / 130°C	122.5 °C	129.1 °C	92.5 °C	102.1 °C
T5 / 80 °C	87.5 °C	94.1 °C	87.5 °C	74.1 °C
T6 / 80 °C	72.5 °C	79.1 °C	55.5 °C	62.1 °C

The following temperature points of the manufacturer with PT100 resistor-type transducer are intended to be operated with the device.

Type designation of the manufacturer	Regulation/Charger no.
90200605-228-1003-5-15-xxx-654-927	600, 710 and 1000
90200605-228-1003-5-15-xxx-254-927	
90200605-228-2003-5-15-xxx-654-927	
90200605-228-2003-5-15-xxx-254-927	
90200610-402-1003-5-8-xxx-104-927	100, 150 and 200
90200610-402-2003-5-8-xxx-104-927	
90200610-228-1003-5-8-xxx-104-927	250
90200610-228-2003-5-8-xxx-254-927	
90200605-227-1003-5-15-xxx-254-927	710
90200605-227-2003-5-15-xxx-254-927	
90200605-406-1003-5-12-xxx-815-927	160
90200605-406-2003-5-12-xxx-815-927	
90200605-407-2003-5-12-xxx-815-927	100, 160, 180 and 220
90200605-607-1003-5-12-xxx-815-927	
90200605-606-2003-5-12-xxx-815-927	100, 160 and 220
90200605-228-2003-5-12-xxx-815-927	
90200610-390-1003-5-8-xxx-104-927	250



UK - Type Examination Certificate EPR 23 UNEX 1 108 X

Revision 0

The following temperature grades of the manufacturer with thermocouple are intended to be operated with the device

Type designation of the manufacturer	Replacement capacitor code
90100055-547-2043-15-xxx-6248/022 90100055-546-2042-15-xxx-6684/022	500, 710 and 5000
90100055-550-2043-6-xxx-668/022 90100055-480-2044-6-xxx-668/022 90100066-503-2046-6-xxx-668/022 90100066-503-2046-6-xxx-668/022	250, 300 and 600
90100054-644-2043-15-xxx-224/022 90100054-644-2043-15-xxx-224/022 90100054-644-2043-15-xxx-224/022 90100054-644-2042-15-xxx-224/022	710
90100055-543-2042-12-xxx-815/022 90100055-543-2042-12-xxx-815/022	220
90100045-551-2043-2-xxx-11-1020-2000/022	90, 2000

Theoretical data:

Permissible ambient temperature range during operation      0 °C < T<sub>a</sub> < +55 °C

- (16) Reference number: 22710203

- (17) Special conditions for safety: none

- For applications that require EPR, CE or EN, CE devices, the safety temperature limiter / safety temperature monitor must be used in accordance with EN 60204-1  
- Only for applications that require LPS, CE or EPR, CE devices, the safety temperature limiter / safety temperature monitor is used as single-channel (ST = 0).  
- This refers to equipment which does not provide an ignition source in fault-free operation but has no fault tolerance with regard to ignition protection.  
- For alternative concepts / applications, the requirements / options according to ISO 80079-37 have to be taken into account.

- (18) Essential Health and Safety Instructions:

Read by comparison with standards:



Warrington, 09-06-2023

Certification services provided on and by VDE. The certificate is subject to the conditions of the manufacturer for the certified EPRs or CE certificates and be submitted to Bureau Veritas

Controlled Product: Electronic control components (EPR 23 UNEX 1 108 X) Revision 0

Manufacturer: Phoenix Contact GmbH, Phoenix Contact (England) Limited

Model: 22710203 Rev. 001

Approved Date: 01 August 2023

Approved by signed name: Company Manager, BVB

Approved Date: 09-06-2023

66

## 18.9 UK Conformity

JUMO GmbH & Co. KG  
 Markt-Juchheim-Strasse 1    Tel: +49 89 8023-0    E-Mail: [info@jumo.de](mailto:info@jumo.de)  
 36039 Fufa, Germany    Fax: +49 89 8023-500    Internet: [www.jumo.de](http://www.jumo.de)

 [More than 100 years of experience](#)

## UK Declaration of Conformity

Document No.    UK 172  
 Manufacturer    JUMO GmbH & Co. KG  
 Address    Markt-Juchheim-Strasse 1, 36039 Fufa, Germany

Product Name    Type    Data sheet no.  
 JUMO safetyM STB STW Ex    701155    701155

**Product description**  
 Safety temperature limiters and monitors according to DIN EN 14597 and Ex approval.

**We hereby declare in sole responsibility that the designated product fulfils the requirements of the statutory instruments.**

**1. Statutory instrument**  
 Name    Electromagnetic Compatibility Regulations 2016  
 2016 No. 1091

**Conformity assessment procedure**  
 Date of first application of the UKCA mark to the product    Mod A  
 2019+A1:2019+A2:2023

**Standards/Specifications applied**

Reference	Edition	Comment
EN 61326-1	2013	
EN 60730-1	2016+A1:2019	
EN 60730-2-9	2019+A1:2019+A2:2020	

**Valid for Type**  
 701155...

Document No.    UK 172    UK Declaration of Conformity    Seite 1 von 5

JUMO GmbH & Co. KG

Strasse: Jülicher Straße 1  
52074 Jülich, Germany Tel: +49 89 3002-0  
Fax: +49 89 3002-500

E-Mail: [mail@jumo.de](mailto:mail@jumo.de)  
Internet: [www.jumo.de](http://www.jumo.de)



More than **100 years** of experience

## 2. Statutory instrument

Name

The Restriction of the Use of Certain Hazardous Substances in Electrical and Electronic Equipment Regulations 2012/2012 No. 3002

Conformity assessment procedure

Mod A

Date of first application of the UKCA mark to the product

Standards/Specifications applied

Reference

Edition

Comment

[VDQ] Umweltschutzanforderungen V1 bei der Produktentwicklung und -gestaltung

Valid for Type

701155/...

## 3. Statutory instrument

Name

Electrical Equipment (Safety) Regulations 2016  
2016 No. 1101

Conformity assessment procedure

Mod A

Date of first application of the UKCA mark to the product

2023

Standards/Specifications applied

Reference

Edition

Comment

EN 60730-1  
EN 60730-2-9

2016+A1:2019  
2019+A1:2019+A2:2020

Valid for Type

701155/...

Document No

UK 172

UK Declaration of Conformity

Sheet 2 von 5

JUMO GmbH & Co. KG  
 Markt-Administration 1 Tel: +49 89 8023-0 E-Mail: markt@jumo.de  
 20237 Focke Germany Fax: +49 89 8023-200 Internet: www.jumo.de



More than **100 years** of experience

#### General remarks

LVD not applicable for type 70115G\*\*\*\*\*059

#### 4. Statutory instrument

##### Name

The Supply of Machinery (Safety) Regulations  
 2008 2008 No. 1597

##### Conformity assessment procedure

Mod A

Date of first application of the UKCA mark to the  
 product 2023

#### Standards/Specifications applied

Reference	Edition	Comment
EN 13949-1	2015	
EN 60204-1	2018	

#### Valid for Type

70115G\*\*\*\*\*059

#### 5. Statutory instrument

##### Name

The Equipment and Protective Systems Intended  
 for Use in Potentially Explosive Atmospheres

##### Conformity assessment procedure

Regulations 2016 2016 No. 1107

Date of first application of the UKCA mark to the  
 product Mod B+D 2023

#### Valid for Type

70115G\*\*\*\*\*045

70115G\*\*\*\*\*044

Document No.

UK 172

UK Declaration of Conformity

Sheet 3 von 5



More than **100 years** of experience

### 5.1 Type examination certificate

Certificate number

EPS 22 UKEX 1 107 X

Designated body

Bureau Veritas Consumer Products Services  
United Kingdom Limited, 31 Kingsland Grange,  
Woodston, Warrington, Cheshire, WA1 4RW

### Standards/Specifications applied

Reference

Edition

Comment

EN 60079-0	2018	
EN 60079-1	2014	
EN 60079-7	2015+A1:2018	
EN 60079-31	2014	
EN 60079-36	2016	
EN 60079-37	2016	
EN 50495	2010	

Valid for Type

701155\*\*\*\*\*045

### 5.2 Type examination certificate

Certificate number

EPS 22 UKEX 2 108 X

Designated body

Bureau Veritas Consumer Products Services  
United Kingdom Limited, 31 Kingsland Grange,  
Woodston, Warrington, Cheshire, WA1 4RW

### Standards/Specifications applied

Reference

Edition

Comment

EN 60079-0	2018	
EN 60079-11	2012	
EN 60079-36	2016	
EN 60079-37	2016	
EN 50495	2010	

**JUMO GmbH & Co. KG**  
 JUMO Automation Straße 1 Tel: +49 89 3023-0 E-Mail: [mail@jumo.de](mailto:mail@jumo.de)  
 36203 Füssen, Germany Fax: +49 89 3023-300 Internet: [www.jumo.de](http://www.jumo.de)



More than **100 years** of experience

Valid for Type  
 7011557-\*\*\*\*\*044-

Quality assurance of the production process  
 Certificate number  
 Designated body

Available on request

Bureau Veritas Consumer Products Services  
 United Kingdom Limited, 31 Kingsland Grange,  
 Woodson, Warrington, Cheshire, WA1 4RW  
 8507

Identification no.

Issued by  
 Place, date  
 Legally binding signatures

JUMO GmbH & Co. KG  
 Füssen, 2023-07-19  
 Director of Global Sales  
 Markus Böhmer

Head of Quality Department

Harald Gierger

Document No.

UK 172

UK Declaration of Conformity

Sheet 5 von 5

## 18.10 China RoHS

部件名称 Product group: 701150/701155	有毒有害物质或元素 Hazardous substances					
	铅 (Pb)	汞 (Hg)	镉 (Cd)	六价铬 (Cr(VI))	多溴联苯 (PBB)	多溴二苯醚 (PBDE)
外壳 Housing (Gehäuse)	○	○	○	○	○	○
过程连接 Process connection (Prozessanschluss)	○	○	○	○	○	○
-螺母 Nut (Mutter)	○	○	○	○	○	○
螺钉 Screw (Schraube)	○	○	○	○	○	○

本表格依据 SJ/T 11364-2014 的规定编制。  
(This table is prepared in accordance with the provisions of SJ/T 11364-2014.)

○ : 表示该有害物质在该部件所有均质材料中的含量均在 GB/T 26572 规定的限量要求以下。  
(O: Indicates that said hazardous substance contained in all of the homogeneous materials for this part is below the limit requirement of GB/T 26572.)

X : 表示该有害物质至少在该部件的某一均质材料中的含量超出 GB/T 26572 规定的限量要求。  
(X: Indicates that said hazardous substance contained in one of the homogeneous materials used for this part is above the limit requirement of GB/T 26572.)







#### **JUMO GmbH & Co. KG**

Street address:  
Moritz-Luchheim-Strabe 1  
36039 Fulda, Germany  
Delivery address:  
Mackerrodtstraße 14  
36039 Fulda, Germany  
Postal address:  
36035 Fulda, Germany  
Phone: +49 661 6003-0  
Fax: +49 661 6003-607  
Email: [mail@jumo.net](mailto:mail@jumo.net)  
Internet: [www.jumo.net](http://www.jumo.net)

#### **JUMO UK LTD**

JUMO House  
Temple Bank, Riverway  
Harrow, Essex, CM20 2DY, UK  
Phone: +44 1279 63 55 33  
Fax: +44 1279 62 50 29  
Email: [sales@jumo.co.uk](mailto:sales@jumo.co.uk)  
Internet: [www.jumo.co.uk](http://www.jumo.co.uk)

#### **JUMO Process Control, Inc.**

6724 Joy Road  
East Syracuse, NY 13057, USA  
Phone: +1 315 437 5866  
Fax: +1 315 437 5960  
Email: [info.us@jumo.net](mailto:info.us@jumo.net)  
Internet: [www.jumousa.com](http://www.jumousa.com)

