

JUMO Panel-mounted thermostat EM

PED Pressure
Equipment
Directive

cRU® **US**

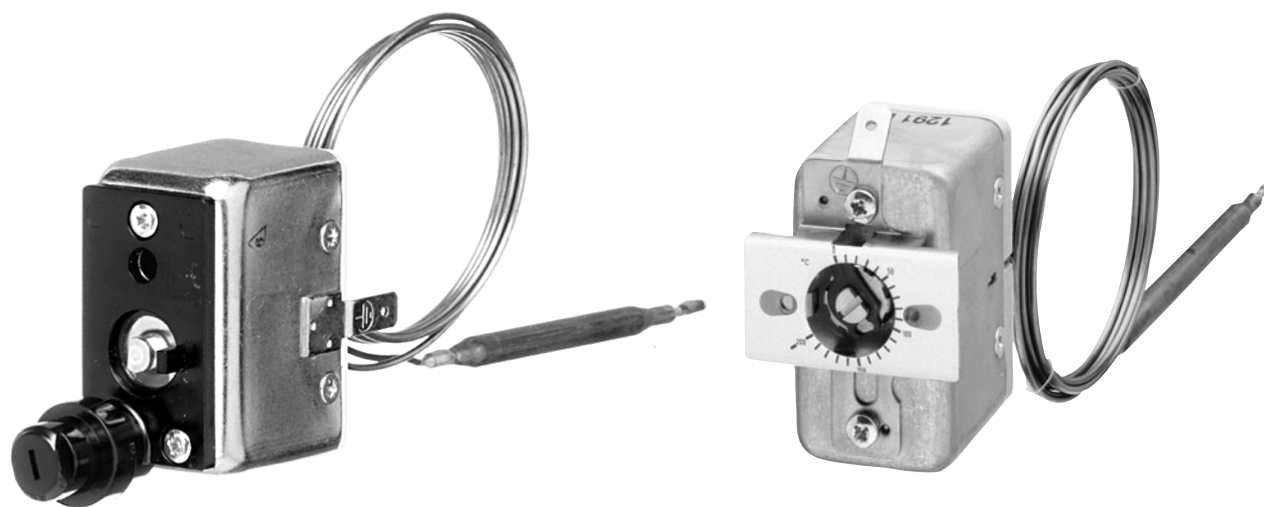

Operating instructions



60202600T90Z001K000

V7.00/EN/00073776/2025-05-21

Please read this operating manual before starting up the device. Keep the operating manual in a place accessible to all users at all times. Please help us to improve these instructions where necessary. Your comments are highly appreciated.

All necessary settings and required work inside the device are described in this operating manual. If any difficulties should still arise during start-up, you are asked not to carry out any unauthorized manipulations on the unit. You could endanger your rights under the device warranty! Please contact the nearest subsidiary or the head office.

Further information and downloads



qr-602026-en.jumo.info

1	Introduction	5
1.1	Typographical conventions	5
1.1.1	Warning signs	5
1.1.2	Indicative signs	5
1.2	Application	6
1.3	Identification	6
1.4	Safety information	7
2	Identifying the device version	8
2.1	Name plate	8
2.2	Order details	9
3	Installation	11
3.1	Dimensions	11
3.2	Fastening the panel-mounted thermostat	12
3.2.1	Fasting the switching head	12
3.3	Capillary, temperature probe, thermowell	13
3.3.1	General information	13
3.3.2	Approved process connections	14
3.3.3	Thermowell made of steel 22, 23, 32, 41, 42 and 45	14
3.3.4	Thermowell made of stainless steel 20, 22, 40 and 41	16
3.3.5	Thermowell made of brass 20 and 40	16
3.3.6	Probe connections 50, 52 and 54	16
4	Installation	18
4.1	Standards and information	18
4.2	Electrical connection	18
4.3	Wiring diagrams	19
5	Settings	20
5.1	Unlocking the safety temperature limiter (STB)	20
5.2	Limit value setting	21
5.3	Switching function	21

Inhalt

6	Technical data	22
6.1	Limit value range, limit value setting, and temperature probe	22
6.2	Capillary and temperature probe	22
6.3	Electrical data	23
6.4	Operating data	24
6.5	Mechanical features	25
6.6	Approval marks and certificates	26

1.1 Typographical conventions

1.1.1 Warning signs



Danger

This symbol is used when there may be **danger to personnel** if the instructions are ignored or not followed correctly!



Caution

This symbol is used where there may be **damage to equipment** if the instructions are disregarded or not followed accurately!

1.1.2 Indicative signs



Note

This symbol is used to draw your **special attention** to a remark.



Reference

This symbol refers to **additional information** in other chapters or sections.

abc¹

Footnote

Footnotes are comments that **refer to specific parts** of the text. Footnotes consist of two parts:

A marker in the text and the foot note text itself.

The markers in the text are arranged as continuous superscript numbers.

The footnote text is located at the end of the page, and is preceded by a superscript number.

*

Handling instructions

This symbol indicates that an **action to be performed** is described.

The individual steps are indicated by asterisks.

1 Introduction

1.2 Application

Thermostats are used to control and monitor thermal processes.

Panel-mounting thermostats operate according to the fluid or gas expansion principle. The electrical switching element is a micro switch.

The devices of the EM type series are available as safety -temperature monitors STW and safety temperature limiters STB.

In the event of a malfunction, the STB switches the monitored machine line to an operational safe status.

Versions as per DIN EN 14597

STW (STB)	Safety temperature monitor
STB	Safety temperature limiter

EC type examination as per:

- DIN EN 14597
- PED-directive 2014/68/EU

You will find the Declarations of Conformity at www.jumo.en.

- Products
- Temperature
- Monitor/Limiter
- Electromechanical
- Panel-mounting thermostats 60.2026
- Documentation
- Declaration of Conformity / White Paper

or ask for them to be sent.



Bending/kinking or cutting the probe line of the panel-mounting thermostats of the EM type series will lead to a permanent device failure!

1.3 Identification

Depending on the device version:



(for detailed information, see name plate)

1.4 Safety information



Filling fluid can emerge in the event of a measuring system break. A hazard to health is excluded as per the present information.

Physical and toxic features of the expansion means, which could emerge in the event of a measuring system break:

Control range with scale limit value °C	Hazardous reaction	Fire and explosion hazard		Hazardous to waters	Information about toxicology		
		Ignition temperature °C	Explosion limit Vol. %		Irritant	Hazardous to health	Toxic
< 200	No	355	0.6 to 8	Yes	Yes	a	No
≤ 200 ≤ 350	No	490	-	Yes	Yes		No
> 350 ≤ 500	No	No	No	No	No	No	No

- a There is currently no statement by the health authority concerning hazards to health in the event of short-term exposure and low concentration, e.g. in the event of a measuring system break.

2 Identifying the device version

2.1 Name plate

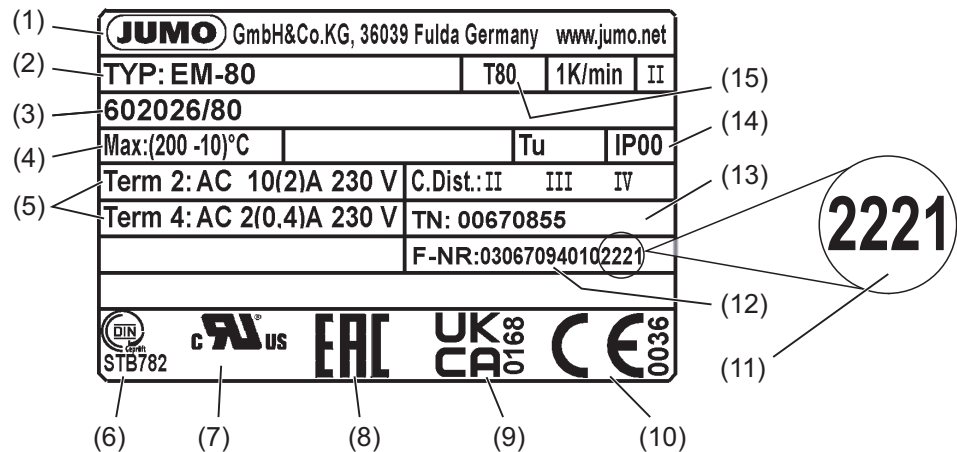

- 1 Manufacturer
- 2 Device designation
- 3 Order code
- 4 Control range or limit value, ambient temperature at which the thermostat was calibrated (optional)
- 5 Switching capacity
- 6 DIN identification marking
- 7 UL identification marking
- 8 EAC identification marking
- 9 UKCA identification marking
- 10 CE identification marking
- 11 Date of manufacture: Year and week
- 12 Fabrication number (F-NR)
- 13 Part number (TN)
- 14 Protection type
- 15 Permissible ambient temperature

2 Identifying the device version

2.2 Order details

	(1) Basic type
602026	JUMO Panel-Mounted Thermostat EM
	(2) Basic type extension
20	EM-20-E Safety temperature monitor STW
30	EM-30-E Safety temperature monitor STW, limit value permanently set
80	EM-80 Safety temperature limiter STB, limit value permanently set
	(3) Control range (TW)
000	With permanently set limit value
055	40 to 110 °C
096	350 to 500 °C
097	500 to 650 °C
508	110 to 170 °C
552	150 to 250 °C
575	180 to 250 °C
606	230 to 300 °C
643	450 to 600 °C
	(4) Limit value (STW/STB)
000	With adjustable control range
95	95 °C
100	100 °C
	(5) Capillary length
1000	1000 mm
2000	2000 mm
3000	3000 mm
4000	4000 mm
5000	5000 mm
	(6) Capillary material
20	CrNi (stainless steel 1.4571)
40	Copper (Cu)
	(7) Process connection
10	Plain cylindrical probe
20	Screw-in thermowell
	(8) Process connection
00	None
13	G 1/2
	(9) Process connection material
00	None
20	CrNi (stainless steel)
46	CuZn (brass)
	(10) Insertion length
000	None
100	100 mm

120	120 mm
150	150 mm
200	200 mm
300	300 mm
(11) Immersion tube diameter	
00	None
8	8 mm
(12) Probe diameter	
6	6 mm
(13) Extra codes	
000	None
025	Central mounting M10 × 1, metall
574	Microswitch with N/C contact, restart lock, and additional signal contact (only for STB)
699	Screw connection up to 2.5 mm ²
702	Snap action contact with gold-plating
704	Switching head mounting with 2 M4 screws, spaced 28 mm
705	Switching head mounting with 2 M3 screws, spaced 33 mm
706	Switching head mounting with 2 M3 screws, spaced 22 mm
707	Temperature compensation
710	Central mounting M10 × 1

Order code (1) (2) (3) (4) (5) (6) (7) -
 / - - - - - - -

Order example 602026 / 80 - 000 - 000 - 1,000 - 40 - 10 -

(8) (9) (10) (11) (12) (13) , ...^a
 - - - - - -

00 - 00 - 000 - 00 - 00 - 000

^a List extra codes in sequence, separated by commas.

3.1 Dimensions

**EM-80
with central
mounting
(standard)**

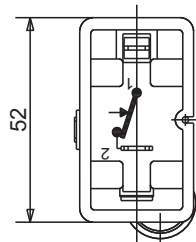
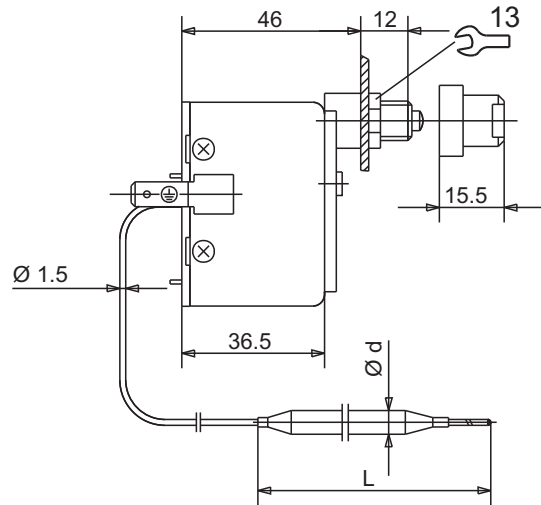
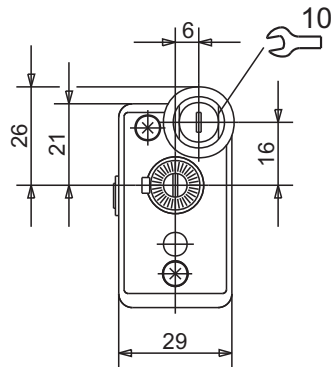

**EM-20-E
EM-30-E
EM-80
with
fastening
bridge
704, 705, 706**

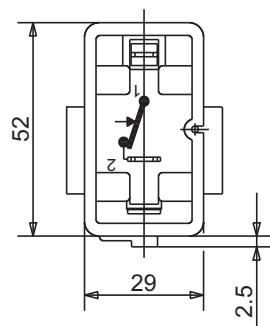
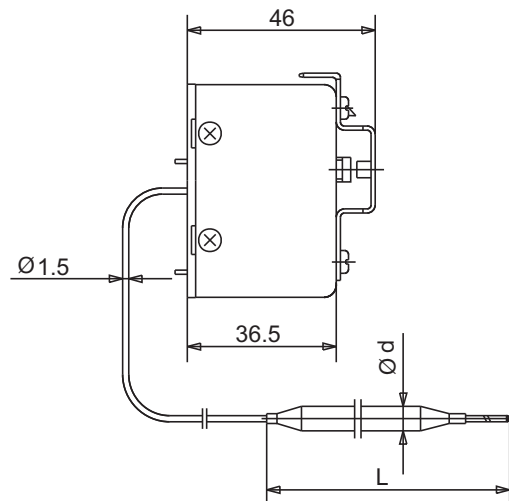
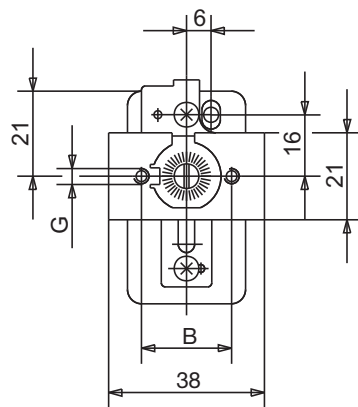

3 Installation

3.2 Fastening the panel-mounted thermostat

Operating position: Any

3.2.1 Fastening the switching head

EM-80 with central mounting

- Central mounting
- 1 Cap nut M10 × 1 (SW10)
 - 2 Fastening nut M10 × 1 (SW13)
 - 3 Panel
 - 4 Restart knob

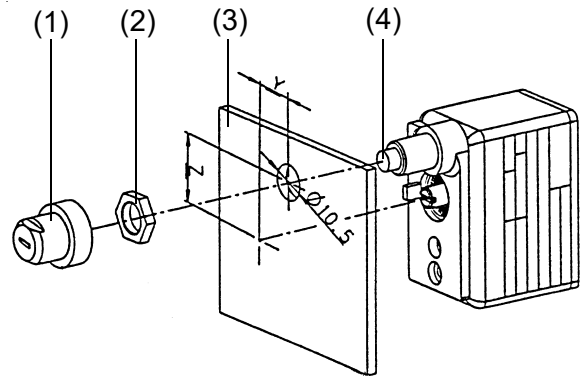

Type	Dimension (mm)	
	X	Y
EM-80	16	6

EM-20-E, EM-30-E, EM-80 with fastening bridge

- With two M3 screws (M4, for extra code 704) on the chassis:
- (1) Screw
 - (2) Panel

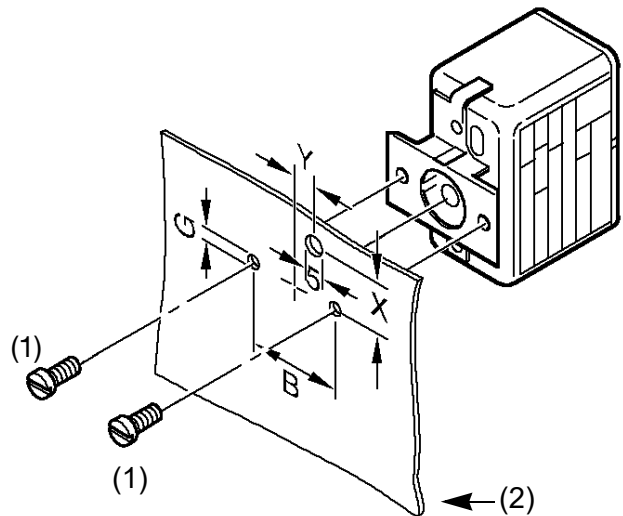

Type	Dimension (mm)	
	X	Y
EM-20-E, EM-30-E	-	-
EM-80	15	6

Extra code (all types)	Dimension (mm)	
	B	G
706 (standard)	3.5	22
704	4.5	28
705	3.5	33

3.3 Capillary, temperature probe, thermowell

3.3.1 General information



Bending/kinking or cutting the capillary of the panel-mounted thermostats will lead to a permanent device failure!

The minimum admissible bending radius of the capillary is 5 mm.

The temperature probe must be installed in JUMO thermowells, otherwise, the approval of the panel-mounted thermostats will become null and void.

Ensure that the temperature probe is completely submerged in the medium to be measured. Ensure that the temperature probe or the thermowell does **not** make contact with the container or pipe walls.

Only use the devices in combination with the factory-supplied thermowell (d = 8 mm or d = 10 mm) to ensure the general response accuracy.

The d = 10 mm thermowells must only be used for d = 8 mm probes.

One thermowell (15 × 0.75 mm) can be used for 2 or 3 cylindrical probes with a diameter of d = 6 mm.

When using a thermowell for 2 probes, fit the factory-supplied contact pressure spring into the thermowell.

For the operating medium air, select the connection type "10" (without thermowell).

For thermowells 22, 41, 42 and 45 made of material St35.8 I, the admissible service life is limited to 200,000 operating hours at operating temperatures exceeding 420 °C. Adhere to the TRD 508 for applications in this range.

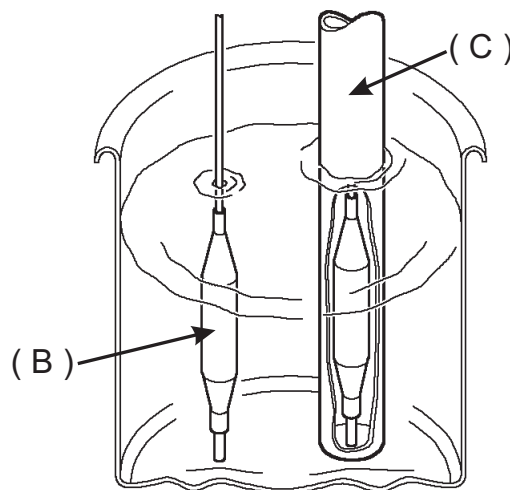

B Temperature probe
C Immersion tube

3 Installation

3.3.2 Approved process connections

Temperature probe	10
Screw-connections	50, 52, 54, 60, 65
Sheaths	20, 21, 22, 23, 24, 40, 41, 42



Refer to data sheet 606710!

3.3.3 Thermowell made of steel 22, 23, 32, 41, 42 and 45

Material

Tube	Screw-in nipples	Welding nipples
St 35.8 I	Steel 1.0038	Steel 1.5415

Capacity

Temperature	Pipe diameter		
	8 × 0.75 mm or conical	10 × 0.75 mm	15 × 0.75 mm
	Maximum admissible pressure		
100 °C	89 bar	72 bar	48 bar
150 °C	83 bar	67 bar	45 bar
200 °C	78 bar	63 bar	42 bar
300 °C	59 bar	47 bar	32 bar
350 °C	50 bar	40 bar	27 bar

Max. admissible operating temperature

Tube	Nipple	Max. admissible operating temperature ^a	
		static load	without load
St 35.8 I	Screw-in nipples	300 °C	530 °C
	Welding nipples	450 °C	

^a Observe the max. admissible probe temperature of the respective thermostat version. For operating temperatures > +420 °C: observe the operating life of 200,000 h at a static load TRD508. Thermowell "21" (UO) and "31" (UZO): Use only in pressureless medium.

3 Installation

Permissible flow rates

Material: St35.8 I
 Temperature: +200 °C
 Heat transfer oil: Air (1)
 water, oil (2)
 Pipe diameter Ø: _____ 8 mm
 - - - - - 10 mm
 15 mm

Permissible flow rate [m/s] at maximum admissible pressure load and different immersion tube length "S"

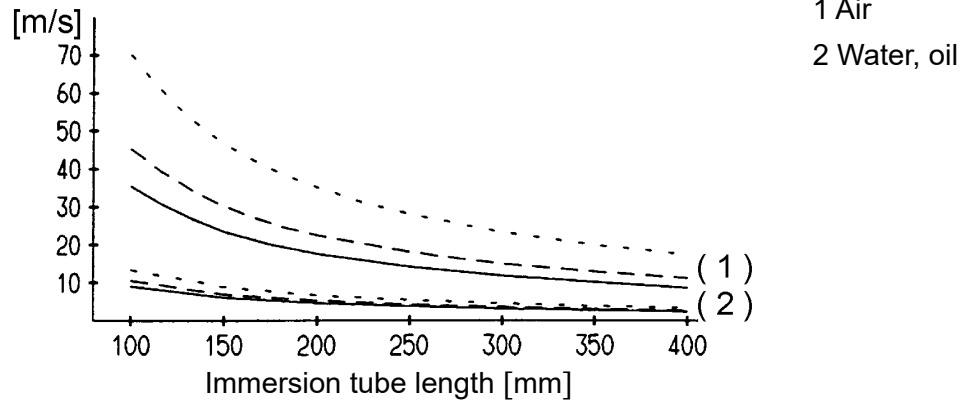

Permissible flow rate [m/s] at maximum admissible pressure load and different immersion tube temperature.

Material: St35.8 I
 Immersion tube length "s": 200 mm
 Heat transfer oil: Air (1)
 water, oil (2)
 Pipe diameter Ø: _____ 8 mm
 - - - - - 10 mm
 15 mm

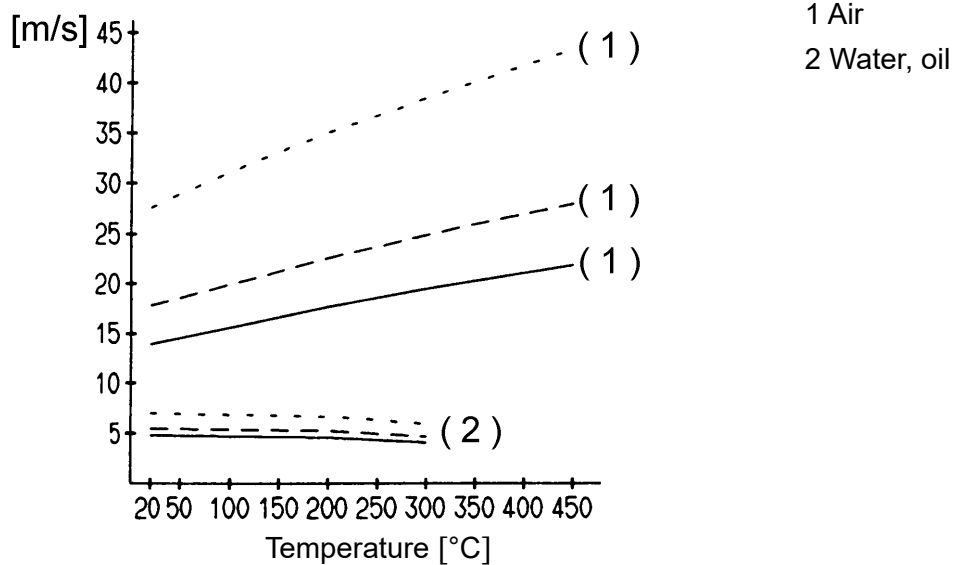

3 Installation

3.3.4 Thermowell made of stainless steel 20, 22, 40 and 41

Capacity

Material of pipe and nipple: Stainless steel (1.4571)			
Temperature	Pipe diameter Ø		
	8 × 0.75 mm or conical	10 × 0.75 mm	15 × 0.75 mm
Maximum admissible pressure			
100 °C	92 bar	74 bar	50 bar
150 °C	88 bar	71 bar	48 bar
200 °C	83 bar	67 bar	45 bar
300 °C	72 bar	58 bar	39 bar
400 °C	67 bar	54 bar	36 bar

3.3.5 Thermowell made of brass 20 and 40

Capacity

Material of pipe and nipple: CuZn, nickel plated			
Temperature	Pipe diameter Ø		
	8 × 0.75 mm	10 × 0.75 mm	15 × 0.75 mm
Maximum admissible pressure			
100 °C	50 bar	40 bar	27 bar
150 °C	48 bar	39 bar	26 bar

3.3.6 Probe connections 50, 52 and 54

(probe making directly contact with the medium)

Material of nipple	CuZn	Steel (1.0038)	Stainless steel (1.4571)
Temperature °C	200	300	400

Probe material	Ø mm	Device function
		STB, STW (STB)
Cu-DHP St35 1.4571	4	2 bar
	5	
	6	
	7	
	8	
	9	
	10	

Design 10, 15, 21, 60, 65:
only use in pressureless medium.



3 Installation



Ensure that the temperature probe (2) is completely submerged in the medium because otherwise, greater switching point deviations will occur.

For connection types 20, 21 and 22, the temperature probe is fixed in the thermowell with the clamping piece (1).

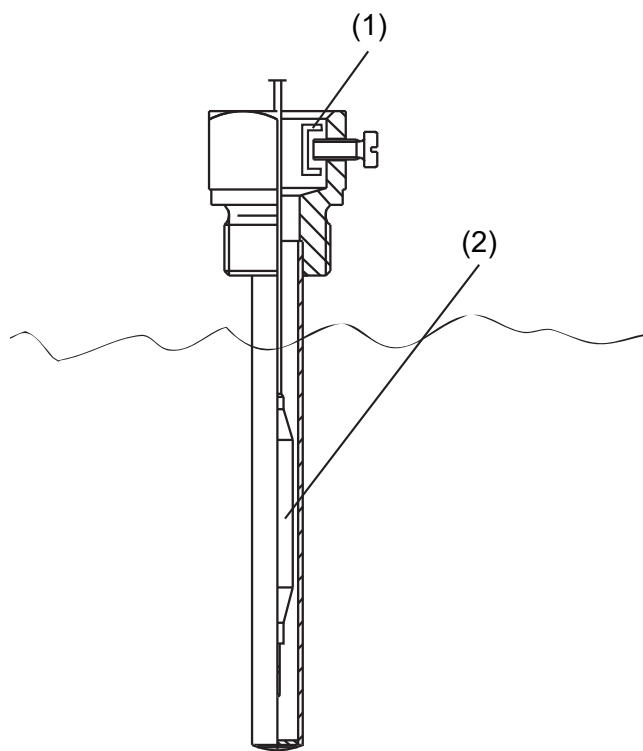

4 Installation

4.1 Standards and information



- Only allow electricians to carry out the electrical connection.
 - The choice of cable, the installation and the electrical connection of the device must conform to the requirements of VDE 0100 "Regulations on the Installation of Power Circuits with Nominal Voltages below 1000 V" and/or the appropriate local regulations.
 - If contact with live parts is possible while working on the device, it must be completely isolated from the supply.
 - Earth the device at the PE terminal to the protective earth conductor. Ensure that this line has at least a cross section identical to that of the supply lines. Earth/ground cables must be routed in a star configuration to a common earthing point that is connected to the protective earth of the supply installation. Do not loop earth cables, i.e. do not run them from one device to another.
 - In addition to a faulty installation, also incorrectly set values on the thermostat could impair the orderly function of the following process or lead to other damage. Restrict the setting to expert personnel. Please adhere to the safety regulations for this case.
-

4.2 Electrical connection

- Terminals and connections are suitable for internal wires
- The connection is suitable for stationary line
- Line insertion without strain relief
- The device corresponds to protection class I.

Capillary tube without protective earth function!



For the probe and the capillar tube, the user is responsible for the required protection against electrical shock.

4 Installation

Plug-in connector (standard)

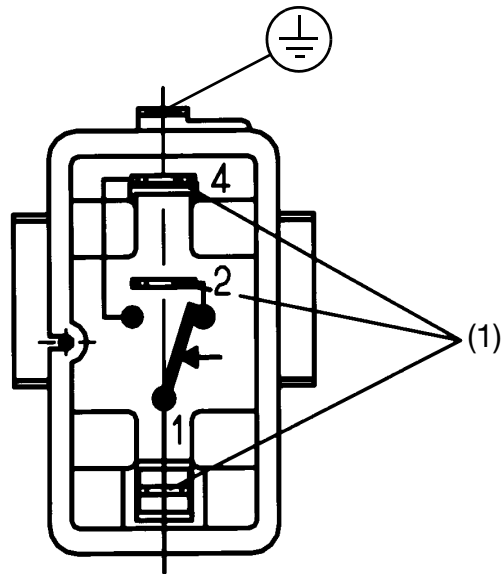

- 1 Tab connector DIN 46 244-A 6.3 × 0.8

Screw-connection (extra code 699)

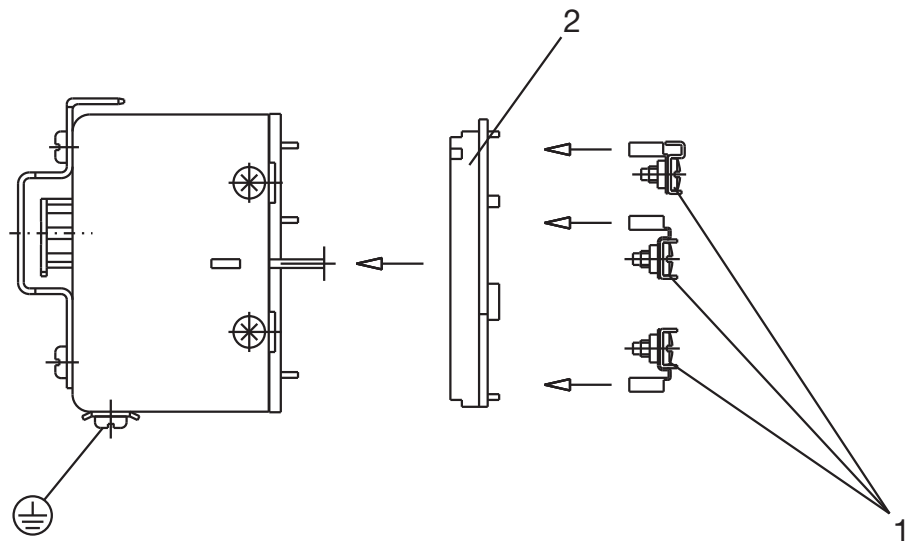

- 1 Plug-in sleeve 6.3 with connection screw suitable for wires up to 2.5 mm²; fitting type "699", without auxiliary means
2 Terminal strip

4.3 Wiring diagrams

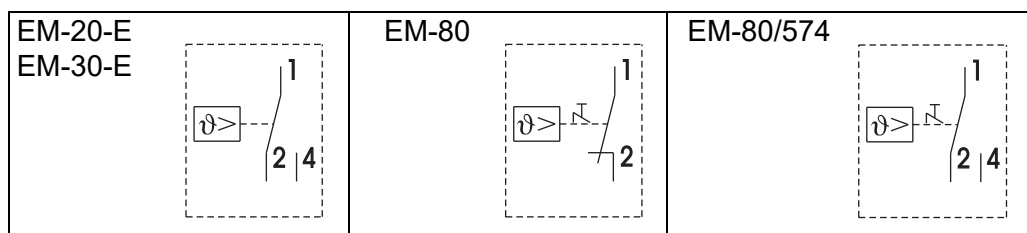

5 Settings

5.1 Unlocking the safety temperature limiter (STB)

EM-80,
with fastening
bridge
704, 705, 706

Once the set limit value is gone below (dangerous temperature) by approx. 10 % of the scale range, the micro switch can be unlocked.

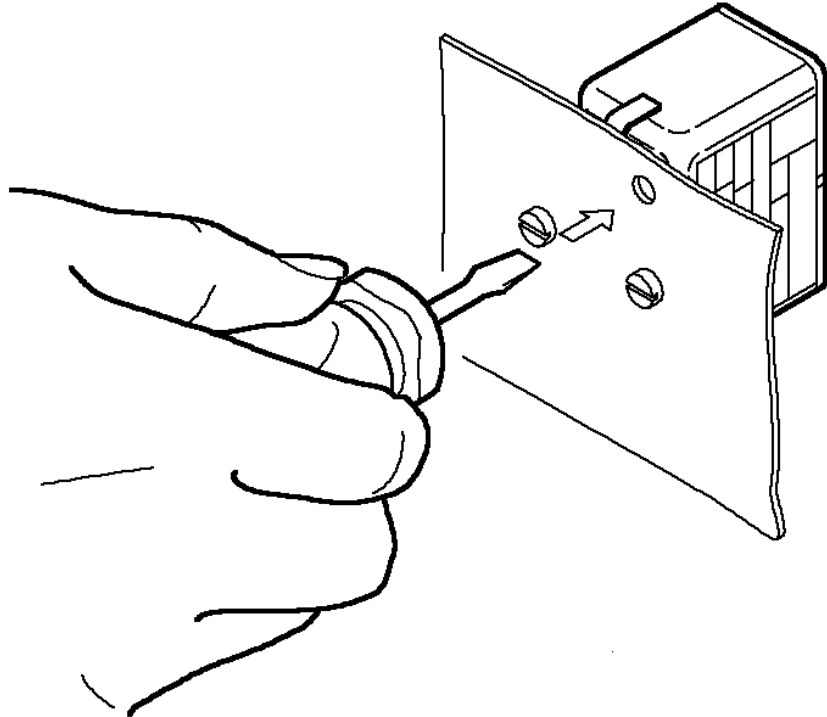

- * Actuate the restart knob using a small screwdriver.
-

EM-80
with central
mounting as
standard

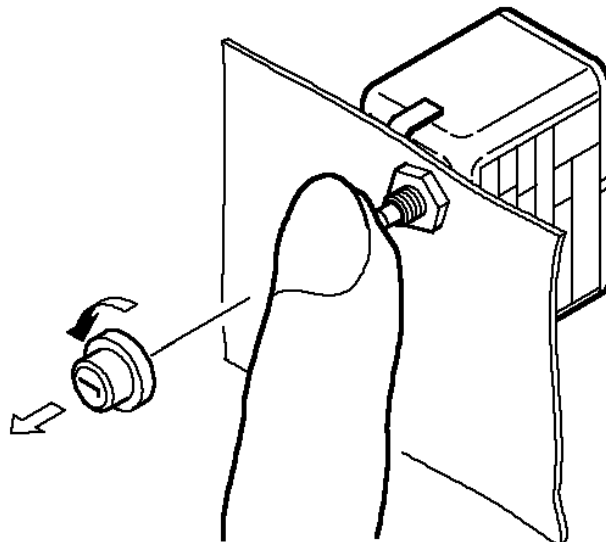

- * Unscrew the cap
 - * Press the restart knob
 - * Screw on the cap
-

5.2 Limit value setting

- EM-20-E
- 1 Set point value setter
 - 2 Scale subdivision
 - 3 Set point value indicator

* Adjust the set point value setter via the internal scale using a screwdriver.

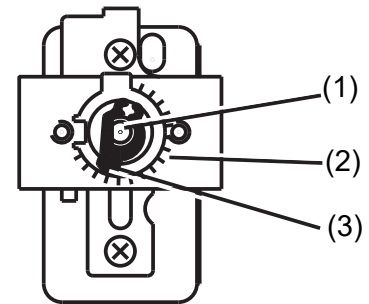

- EM-30-E
EM-80
- The limit value is permanently factory set and sealed.
Readjustment is **not** admissible.

5.3 Switching function

Safety temperature monitor STW (STB)

If the temperature on the temperature probe exceeds the setpoint value, the microswitch is activated by the transmission mechanics and the electrical circuit is opened or closed. If the temperature falls below the selected setpoint value (by the amount of the switching differential), the microswitch is reset to its initial position.

Restart lock of the safety temperature limiter STB

If the temperature on the temperature probe exceeds the set limit value, the electrical circuit is opened and the microswitch is mechanically locked. The microswitch can be manually unlocked once the temperature has dropped by approx. 10 K.

Self-monitoring for the safety temperature limiter STB and safety temperature monitor STW (STB)

If the measuring system is destroyed, that is, if the expansion fluid emerges, the pressure in the membrane drops and permanently opens the electrical circuit of the STB. Unlocking is then no longer possible. The electrical circuit 1-2 opens when the probe of STW (STB) and STB cools down to the negative temperature range, but it closes again automatically if the temperature rises.

Use of the safety temperature monitor STW as a safety temperature limiter STB

The activation lock required by DIN EN 14597 must be warranted by the following circuit diagram. The switching diagram must comply with DIN EN 50156.

6 Technical data

6.1 Limit value range, limit value setting, and temperature probe

	Seuils, Réglage des seuils ^a °C	Température de sonde maximale admissible °C	Tolérance du seuil K	Longueur de la sonde, cote "L", pour Ø de sonde "d" = 6 mm
Type EM-20-E	40 à 110 100 à 150 110 à 170 180 à 250 230 à 300	135 173 195 288 345	0/-9 0/-8 0/-9 0/-13 0/-14	72 85 72 60 60
Type EM-30-E	Seuil au choix 20 à 300 fixe, réglé en usine	Valeur limite 15 %	-	-
Type EM-80	Seuil au choix 60 à 180 fixe, réglé en usine	Valeur limite 15 %	0/-5	84

a Seuils, réglage des seuils.

6.2 Capillary and temperature probe

	Scale limit value	Capillary	Temperature probe
Type EM-..	Up to 200 °C	Copper (Cu) Ø 1.5 mm Material No. Cu-DHP	Copper (Cu) Material No. Cu-DHP hard soldered
	Up to 300 °C	Copper (Cu) Ø 1.5 mm Material No. Cu-DHP	Stainless steel (CrNi) Material No. 1.4571 hard soldered
	Up to 300 °C	Stainless steel (CrNi) Ø 1.5 mm	Stainless steel (CrNi) Material No. 1.4571 welded
Capillary length	Standard: 1000 mm, max. 5000 mm		
Min. bending radius of the capillary	5 mm		

6.3 Electrical data

Switching element	Snap-action switch with single-pole changeover contact
Max. switching capacity On the NC contact (contact deck 1 to 2) STW (STB), STB On the NO contact (contact deck 1 to 4) STW (STB) STB STW (STB), STB for micros- witches with gold-plating	AC 400 V +10 %, 10 A, AC 230 V +10 %, 16 (2.5) ¹ A, cos φ = 1 (0.6), DC 230 V +10 %, 0,25 A AC 400 V +10 %, 6.3 A, AC 230 V +10 %, 6.3 (2.5) ^b A, cos φ = 1 (0.6), DC 230 V +10 %, 0.25 A AC 230 V +10 %, 2 (0.4) A, cos φ = 1 (0.6), DC 230 V +10 %, 0.25 A, (only with extra code 574) AC/DC 24 V, 0.1 A
Switching reliability For silver contacts With gold-plating	Minimum load for maximum switching reliability AC/DC 24 V, 100 mA AC/DC = 10 V, 5 mA
Rated surge voltage	2500 V (via the switching contacts 400 V)
Overtoltage category	II
Electrical connection Standard Extra code 699	Tab connector A 6.3 – 0.8 DIN 46244 Screw connection up to 2.5 mm ² cable cross-section (can be re- fitted)

¹ Inductive loads

6 Technical data

6.4 Operating data

Switching differential in % from the control range/limit value range	Nominal value	Possible actual value
Switching function STW (STB)	7	7-8
Medium ambient temperature influence	When the ambient temperature on the switching head and/or the capillary deviates from the calibration ambient temperature of +22 °C, a switching point offset occurs. Higher ambient temperature = lower switching point Lower ambient temperature = higher switching point	
	STW (STB)	STB
For temperatures with scale limit value/limit value	< 200 °C	≥ 200 °C ≤ 350 °C
Switching differential in %	7	7
Ambient temperature influence on the switching head in %/K	0.43	0.35
Ambient temperature influence on the capillary in %/m	0.09 · K · m	0.07 · K · m
Temperature compensation (TK)	For detailed information see diagram.	
Temperatures		
Admissible storage temperature	-50 to 50 °C	
Admissible ambient temperature for use	T80	
Nominal position (NL)	Any	
Operating medium	Water, oil, air, superheated steam	
Time constant $t_{0.632}$		
In water	≤ 45 s	
In oil	≤ 60 s	
In air or superheated steam	≤ 120 s	
Mode of operation	EN 60730, DIN EN 60730-2-9, DIN EN 14597	
STW (STB)	2 BKLNP	
STB	2 BFHKLNPV	

6.5 Mechanical features

Housing



Material	Galvanized sheet steel
Fastening	
Extra code 704	With 2 M4 screws, spacing 28 mm
Extra code 705	With 2 M3 screws, spacing 33 mm
Extra code 706	With 2 M3 screws, spacing 22 mm
Extra code 710	Central mounting M10 × 1 with acorn nut (for STB only)
Protection type	IP00, according to EN 60 529, pollution degree 2
Weight	Approx. 200 g

Process connection

Material	
Protection tube up to 150 °C	CuZn (brass) (standard)
Protection tube over 150 °C	CrNi (stainless steel)
Capillary	Plain cylindrical probe (standard) Screw-in protection tube (upon request) Screw-in sleeve with screw-in sigot G 1/2", form A, according to DIN 3852/2, and clamping piece with fixing screw for securing the probe
Insertion length S	
Standard	100, 120, 150, 200 or 300 mm (other length upon request)
Protection tube Ø	D = 8 mm

6 Technical data

6.6 Approval marks and certificates

	Designation Testing agency Certificate no. Inspection basis Valid for	DIN DIN CERTCO/TÜV Süd STB782 DIN EN 14597 Type 602026/80 (EM-80)
	Designation Testing agency Certificate no. Inspection basis Valid for	DIN DIN CERTCO/TÜV Süd STW(STB)775S DIN EN 14597 Type 602026/20 (EM-20-E), Type 602026/30 (EM-30-E)
	Designation Testing agency Certificate no. Inspection basis Valid for	DIN TÜV Süd C-T 1370-01/11, B _{10d} -Wert = 250,000 ¹ DIN EN 14597, DIN EN ISO 13849-1, draft DIN EN 13611 A2 Type 602026/.. (EM-..)
	Designation Testing agency Certificate no. Inspection basis Valid for	PED TÜV Süd Z-IS-TAF-MUC-18-06-2652099-07102504 Directive 2014/68/EU, DIN EN 14597 Type 602026/.. (EM-..)
	Designation Testing agency Certificate no. Inspection basis Valid for	UL Underwriter Laboratories E66358 UL 873, CSA-C22.2 No. 24 Type 602026/80 (EM-80)
	Designation Testing agency Certificate no. Inspection basis Valid for	UL Underwriter Laboratories MH45736 UL 353, CSA-C22.2 No. 24 Type 602026/80 (EM-80)

¹ For further details see safety manual for JUMO Panel-mounted thermostat EM: 602021, 602026.

Russian documentation available upon request.



JUMO GmbH & Co. KG

Street address:
Moritz-Juchheim-Straße 1
36039 Fulda, Germany
Delivery address:
Mackenrodtstraße 14
36039 Fulda, Germany
Postal address:
36035 Fulda, Germany
Phone: +49 661 6003-0
Fax: +49 661 6003-607
Email: mail@jumo.net
Internet: www.jumo.net

JUMO UK LTD

JUMO House
Temple Bank, Riverway
Harlow, Essex, CM20 2DY, UK
Phone: +44 1279 63 55 33
Fax: +44 1279 62 50 29
Email: sales@jumo.co.uk
Internet: www.jumo.co.uk

JUMO Process Control, Inc.

6724 Joy Road
East Syracuse, NY 13057, USA
Phone: +1 315 437 5866
Fax: +1 315 437 5860
Email: info.us@jumo.net
Internet: www.jumousa.com

