

JUMO dTRON 304/308/316 plast

Compact Controller for the plastics industry



Type 703045



Type 703046



Type 703048

B 703046.0

Operating Manual







Please read this operating manual before commissioning the instrument. Keep the manual in a place which is accessible to all users at all times.

Your comments are appreciated and may help us in improving this manual.

All necessary settings are described in this operating manual. Manipulations not described in the manual or expressly forbidden will jeopardize your warranty rights. Please contact the nearest subsidiary or the head office, should you encounter problems.

This manual is valid from **instrument software version 192.02.06**.

It appears by simultaneously pressing the  and  keys.



When accessing the inner parts of the unit and returning modules, assemblies or components, please observe the regulations according to EN 61340-5-1 and EN 61340-5-2 „Protection of electrostatic sensitive devices“. Only use **ESD** packaging for transport.

Please note that we cannot accept any liability for damage caused by ESD.

ESD=Electro Static Discharge

1	Introduction	7
1.1	Description	7
1.2	Typographical conventions	8
2	Identifying the instrument version	9
2.1	Type designation	9
2.2	Scope of delivery	10
2.3	Accessories	10
3	Mounting	11
3.1	Mounting site and climatic conditions	11
3.2	Dimensions	11
3.2.1	Type 703048	11
3.2.2	Type 703046	12
3.2.3	Type 703045	13
3.3	Side-by-side mounting	13
3.4	Fitting in position	14
3.5	Removing the controller module	14
4	Electrical connection	15
4.1	Installation notes	15
4.2	Electrical isolation	16
4.3	Connection diagrams	17
4.3.1	Type 703045	17
4.3.2	Type 703046/48	20
4.3.3	Termination resistor for the RS422/485 serial interface	24
4.3.4	Connection of the PROFIBUS-DP connector	24

5	Operation	25
5.1	Displays and controls	25
5.2	Level concept	26
5.3	Level inhibit	27
5.4	Entries and operator prompting	28
5.5	Fixed-setpoint controller (ex-factory)	29
5.6	Program controller	30
5.6.1	Entering programs	30
5.6.2	Operation	32
5.6.3	Shifting the program profile	33
6	Operator level	35
7	Parameter level	37
8	Configuration	39
8.1	Analog inputs “InP”	41
8.1.1	Customized fine tuning	45
8.2	Controller “Cnt”	47
8.3	Generator “Pro”	55
8.4	Limit comparators “LC”	58
8.5	Outputs “OutP”	62
8.6	Binary functions “binF”	65
8.7	Display “diSP”	69
8.8	Timer “tFct”	71
8.9	Interfaces “IntF”	72
9	Tuning (optimization)	75
9.1	Self-tuning (self-optimization)	75
9.2	Checking the tuning	78
10	Extra codes	79
10.1	Math and logic module	79
10.2	Difference, humidity or ratio controller	79

Contents

11	Retrofitting of modules	81
12	Appendix	83
12.1	Technical data	83
12.2	Alarm messages	86
13	Index	87

Contents

1 Introduction

1.1 Description

This controller series consists of three freely programmable instruments in different DIN formats for controlling temperature, pressure and other process variables for special applications in the plastics industry – applications such as: extruders, injection molding machines, tempering equipment and hot-channel systems.

The high-contrast, multicolor LC display for process value, setpoint and operator prompting contains two four-digit 7-segment displays, one two-character 16-segment display, display of the active setpoints, six switch status indicators, and displays for the dimensional unit, ramp function and manual operation.

Simple operation through four keys. The instruments can be used as 2-state, 3-state, modulating or continuous controllers. The controller software includes, amongst others, a hot-channel warm-up ramp function, control loop and output level monitoring, two self-tuning (self-optimization) procedures, a math and logic module, as well as 4 limit comparators.

Linearizations for the usual transducers are stored, and a customer-specific linearization table can be programmed.

A setup program is available for user-friendly configuration from a PC.

An RS422/485, Profibus-DP, or current interface can be used to integrate the instrument into a data network.

The electrical connection is made at the back of the instrument, via screw terminals.

The possible input and output configurations are shown in the following block diagram. The option boards are universally applicable for all instruments in the series.

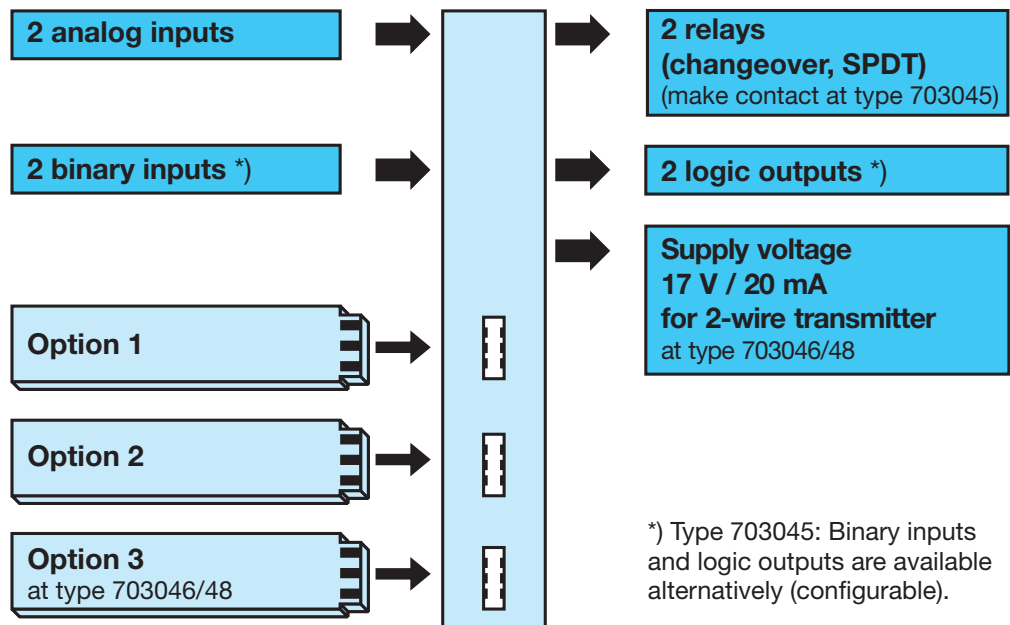

1 Introduction

1.2 Typographical conventions

Warning signs



Danger

This symbol is used when there may be **danger to personnel** if the instructions are ignored or not followed correctly!



Caution

This symbol is used when there may be **damage to equipment or data** if the instructions are ignored or not followed correctly!



Caution

This symbol is used where special care is required when handling components liable to damage through electrostatic discharge.

Note signs



Note

This symbol is used when **your special attention** is drawn to a remark.



Reference

This symbol refers to further information in other operating instructions, chapters or sections.



Action instruction

This symbol indicates that an action to be performed is described.

The individual steps are marked by this asterisk, e.g.

* Press **EXIT**

Representation

Menu items

Texts from the setup program are shown in italics, for example: *edit program*.

Blinking display



2 Identifying the instrument version

2.1 Type designation

Basic type	
703045	JUMO dTRON 316 plast, 48mm x 48mm format incl. analog input, 2 relays and 2 binary inputs or 2 logic outputs
703046	JUMO dTRON 308 plast, 48mm x 96mm format (portrait format) incl. analog input and 2 binary inputs, 2 relays and 2 logic outputs
703048	JUMO dTRON 304 plast, 96mm x 96mm format incl. analog input and 2 binary inputs, 2 relays and 2 logic outputs

Basic type extensions	
2	Basic type 2
	Version
8	standard, with factory settings
9	programming to customer specification
	logic outputs (2 are available as standard)
1	0 / 12V
2	0 / 18V

1.	2.	3.	Option slot	Type 703046/48 Max. number	Type 703045 (no option 3)		
					Max. number	Option 1	Option 2
0	0	0	not used			X	X
1	1	1	analog input 2 (universal)	1	1	X	X
2	2	2	relay (changeover, SPDT)	2	1	X	-
3	3	3	2 relays (make, SPST-NO)	2	1	X	-
4	4	4	analog output	2	2	X	X
5	5	5	2 binary inputs	2	1	X	X
6	6	6	solid-state relay 1A	2	2	X	X
7	7	7	RS422/485 interface	1	1	X	X
8	8	8	Profibus-DP interface	1	1	X	X
9	9	9	0/20 mA current interface	1	1	X	X

X = allowed in this option slot, - = not allowed in this option slot

Supply	
2	3 110 – 240V AC -15/+10%, 48 – 63Hz
2	5 20 – 30V AC/DC, 48 – 63Hz

Extra codes	
0	0 0 none
2	1 4 math and logic module
2	1 7 ratio controller (requirement: 2 analog inputs)
2	1 8 difference controller (requirement: 2 analog inputs)
2	1 9 humidity controller (requirement: 2 analog inputs)

/ 2 - - /

703046 / 2 8 1 - 1 4 0 - 2 3 / 0 0 0

2 Identifying the instrument version

2.2 Scope of delivery

- controller
- seal
- mounting brackets
- Operating Manual in DIN A6 format

A CD with demo software and PDF documents in DIN A4 format (operating manual and further documentation) can be ordered separately.

The individual documents and programs are available for download from www.jumo.net (The software can be enabled for a fee.)

2.3 Accessories

PC interface PC interface with TTL/RS232 converter and adapter (socket connector) for setup program
Part no. 00350260

USB interface PC interface with TTL/USB converter and 2 adapters for setup program
Part no. 00456352

Setup program Setup program with program editor and Startup¹
Part no. 00445443

Hardware requirements:

- PC
- 512 MB RAM, 200 MB free fixed disc memory
- CD/DVD drive (optional)
- free serial or USB interface

Software requirements:

Microsoft¹ Windows XP/VISTA/7/8/10

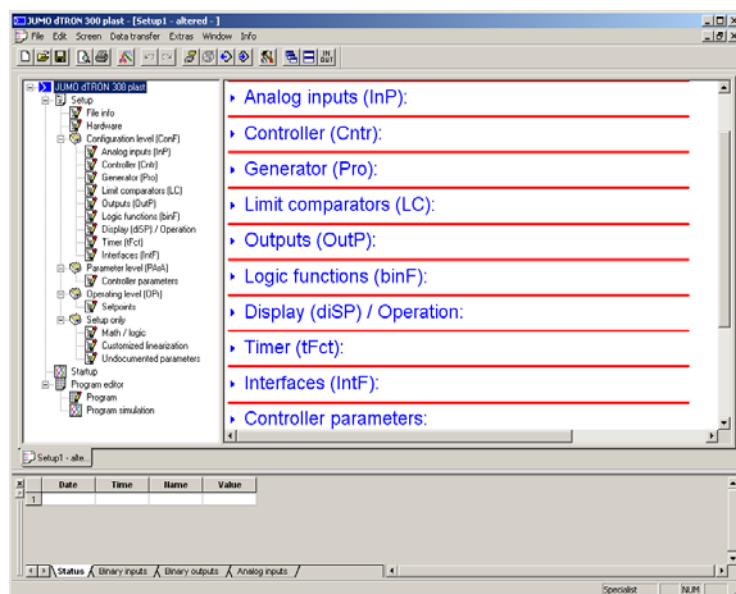

1. Microsoft is a registered trademark of Microsoft Corporation

3 Mounting

3.1 Mounting site and climatic conditions

The conditions on the mounting site must meet the requirements specified in the technical data. The ambient temperature on the mounting site can be from 0 to 55 °C, with a relative humidity of not more than 90 %.

3.2 Dimensions

3.2.1 Type 703048

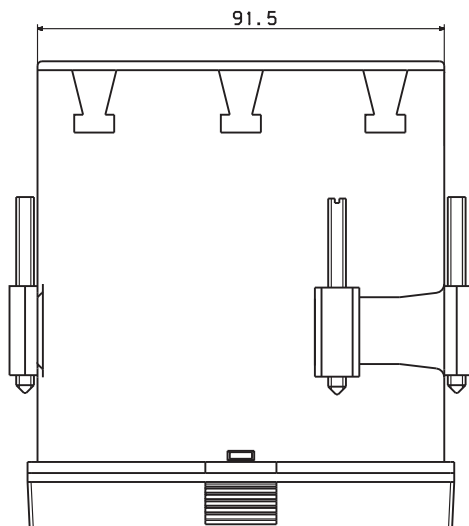
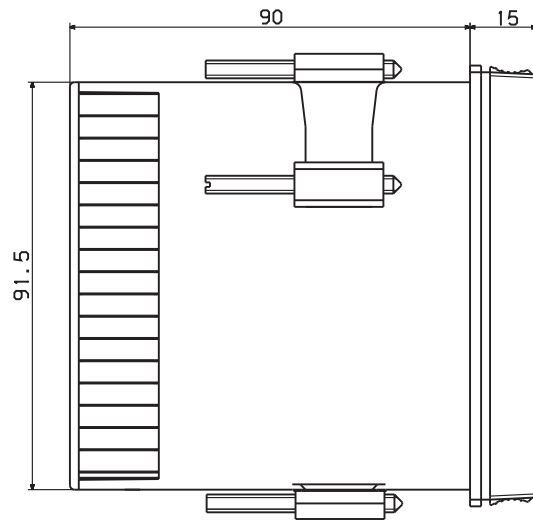
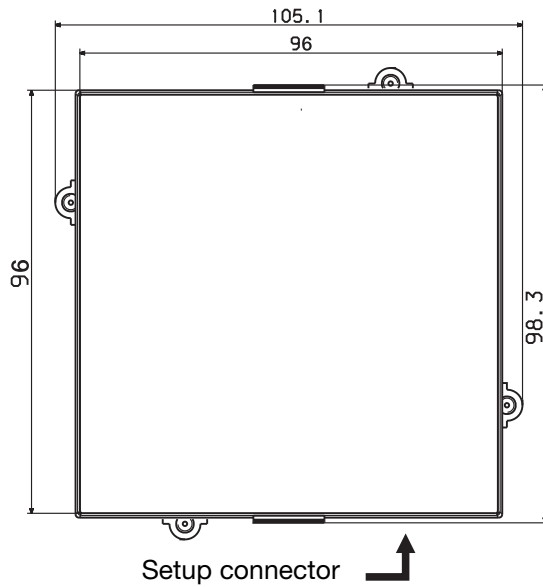

Panel cut-out

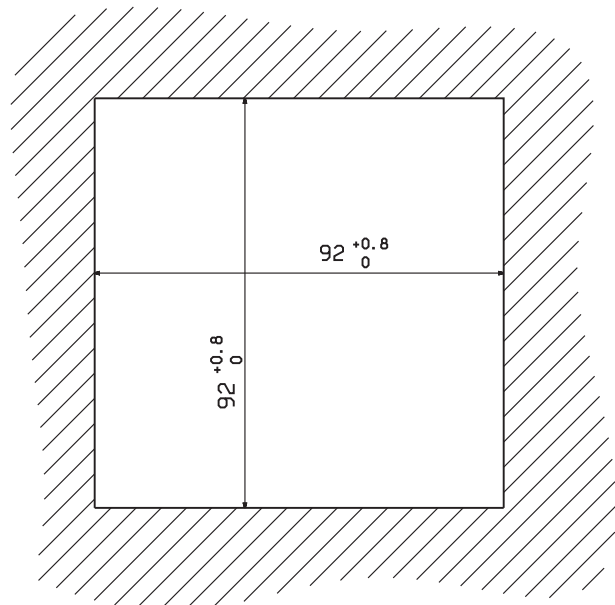

3 Mounting

3.2.2 Type 703046

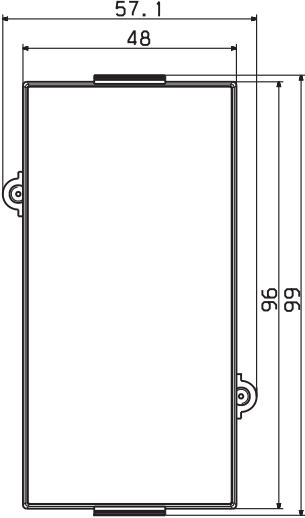

Setup connector 

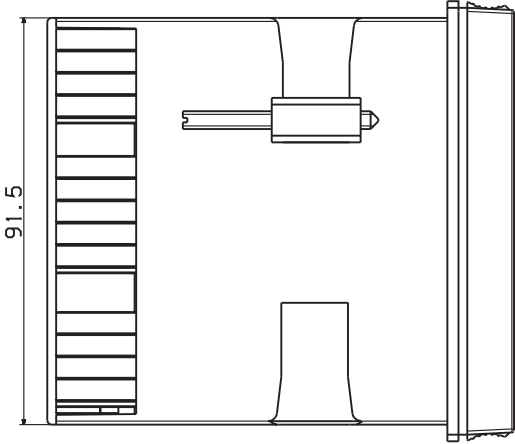

Panel cut-out

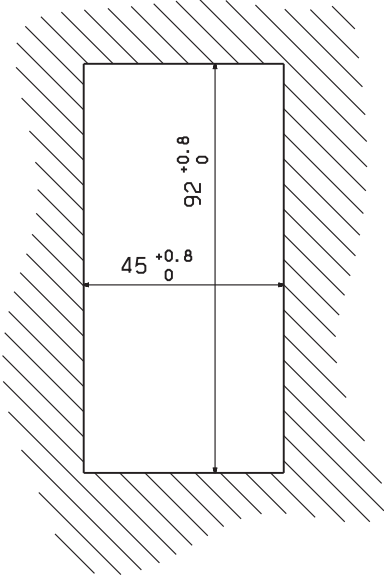
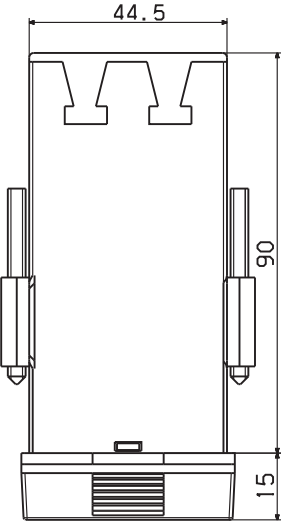

3 Mounting

3.2.3 Type 703045

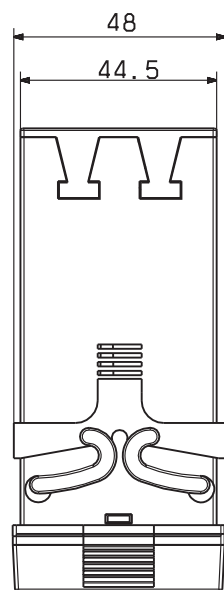
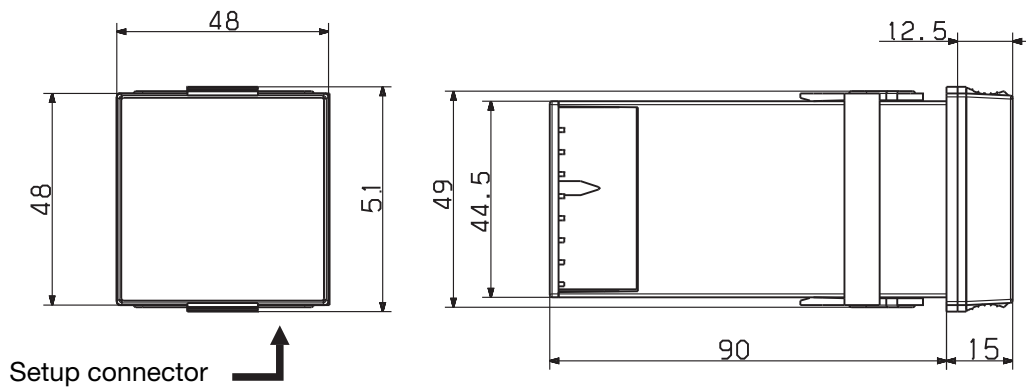

Panel cut-out

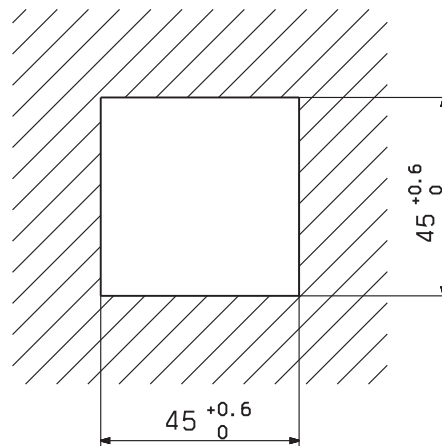

3.3 Side-by-side mounting

Minimum spacing of panel cut-outs		
Type	horizontal	vertical
without setup connector:		
703045 (48mm x 48mm)	11 mm	30mm
703046 (portrait format: 48mm x 96mm)	11 mm	30mm
703048 (96mm x 96mm)	11 mm	30mm
with setup connector (see arrow):		
703045 (48mm x 48mm)	11 mm	65mm
703046 (portrait format: 48mm x 96mm)	11 mm	65mm
703048 (96mm x 96mm)	11 mm	65mm

3 Mounting

3.4 Fitting in position

Type 703046/48

- * Fit the seal that is supplied onto the instrument body.
- * Insert the controller from the front into the panel cut-out.
- * From behind the panel, slide the mounting brackets into the guides on the sides of the housing. The flat faces of the mounting brackets must lie against the housing.
- * Push the mounting brackets up to the back of the panel, and tighten them evenly with a screwdriver.

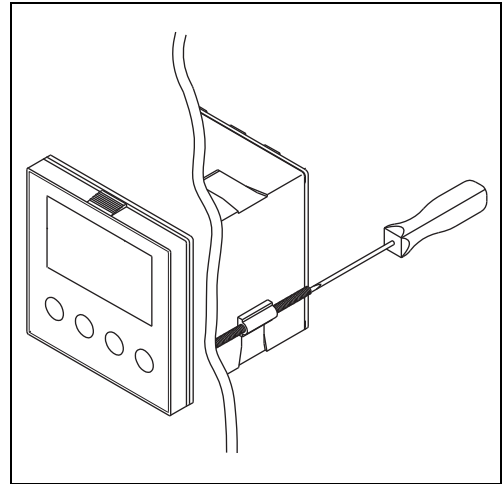

Type 703045

- * Fit the seal that is supplied onto the instrument body.
- * Insert the controller from the front into the panel cut-out.
- * From the back of the panel, push the mounting frame onto the instrument body and press it against the back of the panel, compressing the springs, until the latches snap into the notches provided and it is firmly fixed in position.

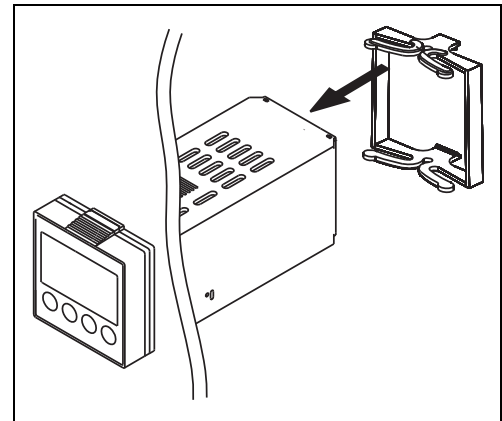

Care of the front panel

The front panel can be cleaned with normal commercial washing, rinsing and cleaning agents. It has a limited resistance to organic solvents (e.g. methylated spirits, white spirit, P1, xylol etc.). Do not use high-pressure cleaning equipment.

3.5 Removing the controller module

The controller module can be removed from its housing for servicing.

- * Press together the knurled areas (top and bottom, or left and right for landscape format) and pull out the controller module.



When inserting the controller module, make sure that the latches (below the knurled areas) snap into place.

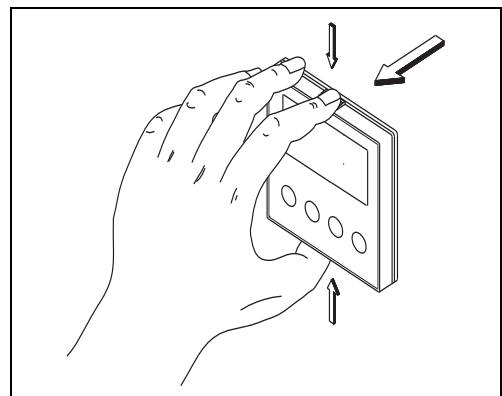

4 Electrical connection

4.1 Installation notes

- The choice of cable, the installation and the electrical connection must conform to the requirements of VDE 0100 “Regulations on the Installation of Power Circuits with Nominal Voltages below 1000 V” or the appropriate local regulations.
- The electrical connection must only be carried out by qualified personnel.
- The instrument shall be operated by mains protected with a branch circuitry overcurrent protection device not more than 20 Amps.
For servicing/repairing a Disconnecting Device shall be provided to disconnect all conductors.
- The load circuit must be fused for the maximum relay current, in order to prevent the output relay contacts becoming welded in the event of a short circuit.
- Electromagnetic compatibility conforms to the standards and regulations cited in the technical data.
- Run input, output and supply cables separately and not parallel to one another.
- Sensor and interface cables should be shielded cables with twisted conductors. Do not run them close to current-carrying components or cables. Ground the shielding on one side.
- Do not connect any additional loads to the supply terminals of the instrument.
- The instrument is not suitable for use in areas with an explosion hazard (Ex areas).
- In addition to faulty installation, incorrect settings on the controller (setpoint, data of the parameter and configuration levels, internal alterations) can also interfere with the correct operation of dependent processes, or even cause damage. Safety devices should always be provided that are independent of the controller (such as overpressure valves or temperature limiters/monitors) and only capable of adjustment by specialist personnel. Please observe the relevant safety regulations for such matters. Since adaptation (self-optimization) can not be expected to handle all possible control loops, an unstable parameterization is theoretically possible. The stability of the actual value that is produced should therefore be checked.



The electrical connection must only be carried out by specialist personnel.



The instrument version can be identified by the type code.

Conductor cross-sections and core-end ferrules for installation

	Minimum cross-section	Maximum cross-section	Min. length of core-end ferrule
Without core-end ferrule	0.34mm ²	2.5mm ²	10mm (stripped)
Core-end ferrule, no lip	0.25mm ²	2.5mm ²	10mm
Core-end ferrule, lip up to 1.5mm²	0.25mm ²	1.5mm ²	10mm
Core-end ferrule, lip above 1.5mm²	1.5mm ²	2.5mm ²	12mm
Twin ferrule with lip	0.25mm ²	1.5mm ²	12mm

4 Electrical connection

4.2 Electrical isolation

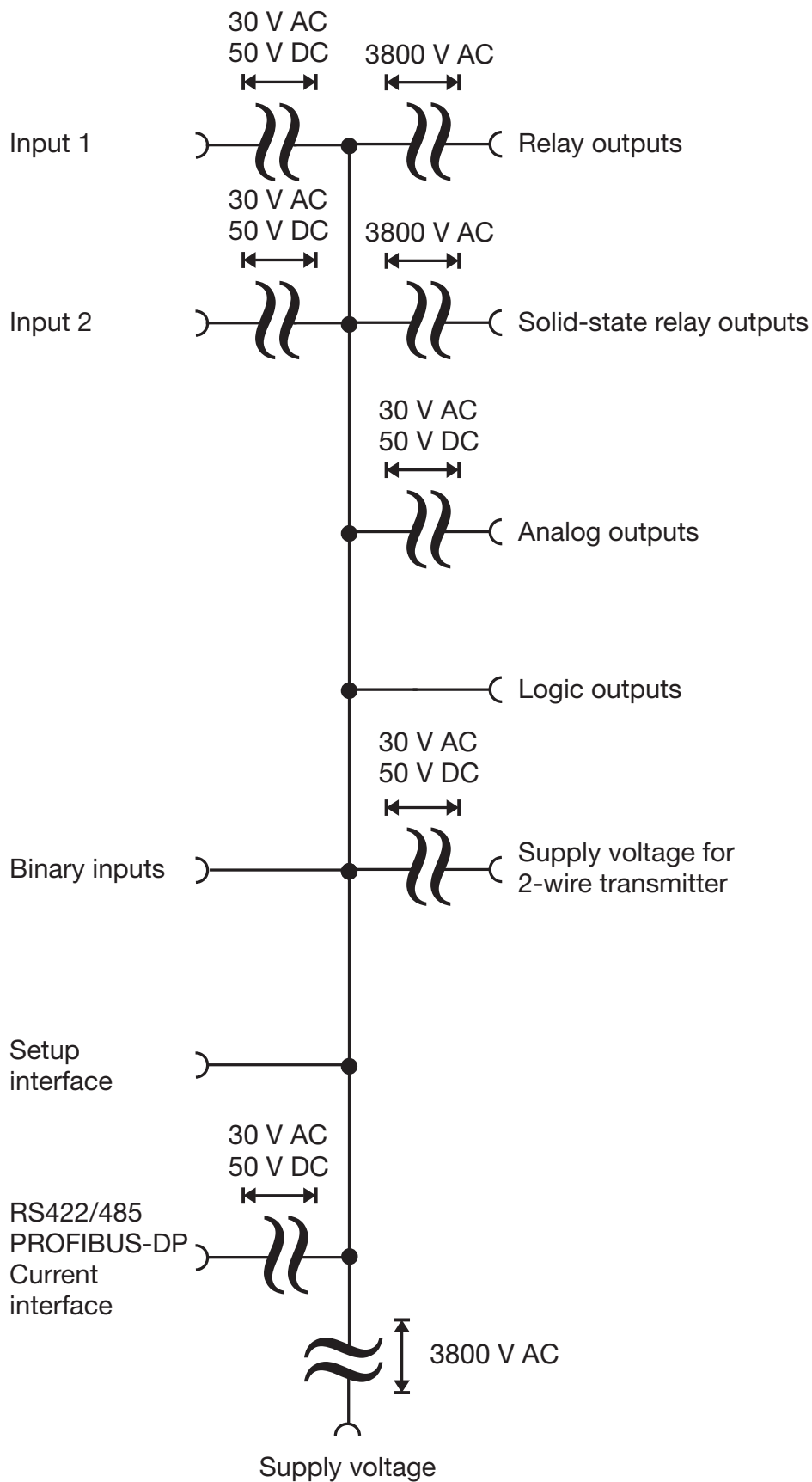

4.3 Connection diagrams

4.3.1 Type 703045

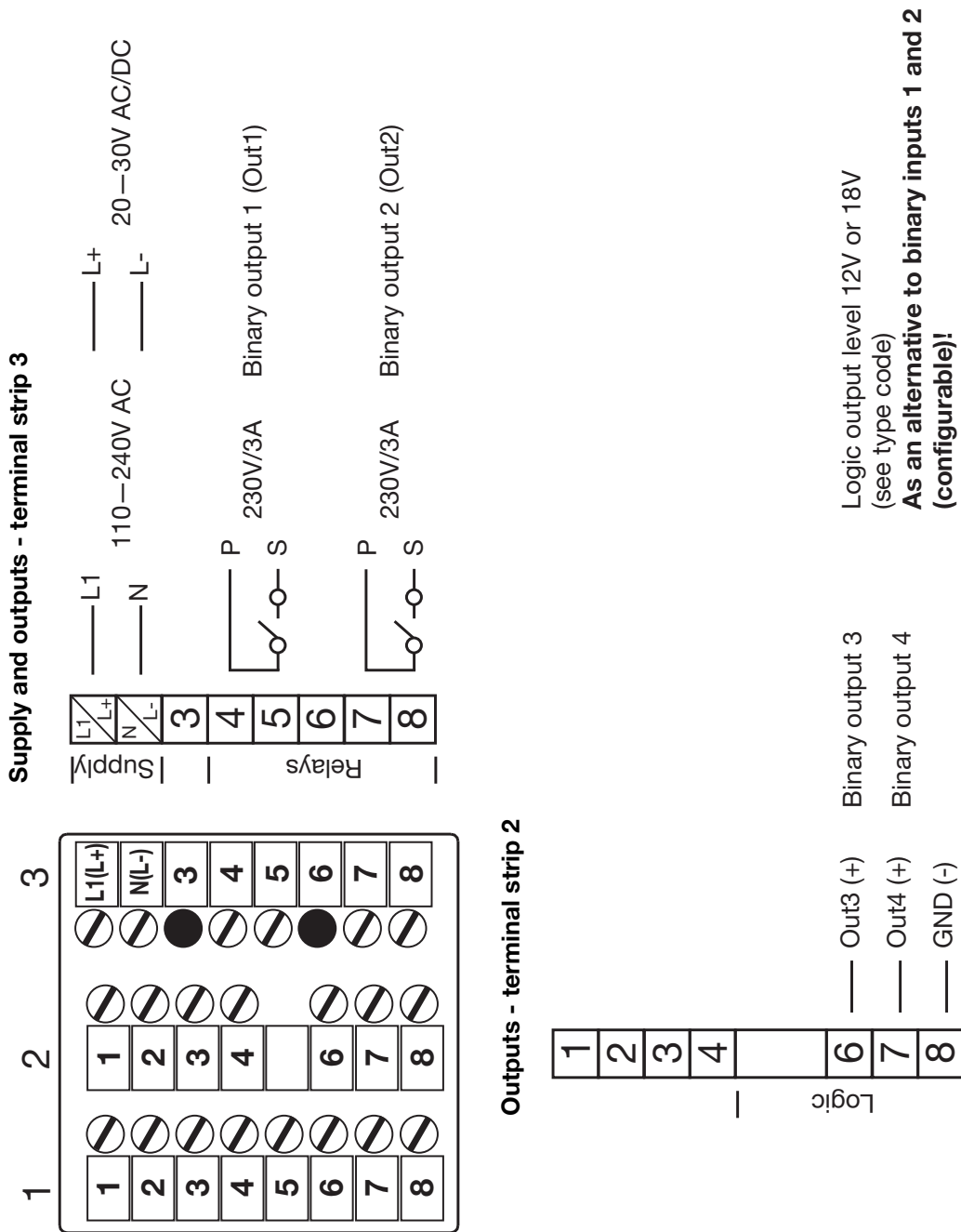

Type 703045 continued

4 Electrical connection

	Analog output	Relay (changeover)	2 relays (n.o. make)	Solid-state relay	PROFIBUS	RS422	RS485	Current interface
Option 1	1 ----- + U _x / k -			----- 	----- VP (+5 V) ----- RxD/TxD-P (B) ----- RxD/TxD-N (A) ----- DGND	----- RxD + ----- RxD - ----- TxD + ----- TxD - ----- RxD +	----- Rx485 + ----- Rx485 - ----- Rx485 + ----- Rx485 -	----- I in ----- I out ----- I out
Option 2	2 ----- + U _x / k -	Binary output 5 (Out5) ----- (not possible)	Binary output 5+8 (Out5+Out8) ----- (not possible)	Binary output 5 (Out5) 	Binary output 5 (Out5) ----- VP (+5 V) ----- RxD/TxD-P (B) ----- RxD/TxD-N (A) ----- DGND	Binary output 5 (Out5) ----- RxD + ----- RxD - ----- TxD + ----- TxD - ----- RxD +	Binary output 5 (Out5) ----- Rx485 + ----- Rx485 - ----- Rx485 + ----- Rx485 -	Binary output 5 (Out5) ----- I in ----- I out ----- I out
	3 ----- + U _x / k -	Binary output 5 (Out5) ----- (not possible)	Binary output 5+8 (Out5+Out8) ----- (not possible)	Binary output 6 (Out6) 	Binary output 6 (Out6) ----- VP (+5 V) ----- RxD/TxD-P (B) ----- RxD/TxD-N (A) ----- DGND	Binary output 6 (Out6) ----- RxD + ----- RxD - ----- TxD + ----- TxD - ----- RxD +	Binary output 6 (Out6) ----- Rx485 + ----- Rx485 - ----- Rx485 + ----- Rx485 -	Binary output 6 (Out6) ----- I in ----- I out ----- I out



Note numbering of outputs.

⇒ Chapter 8.5 “Outputs “OutP””

Type 703045 continued

Analog input 1 and binary inputs 1+2 - terminal strip 2

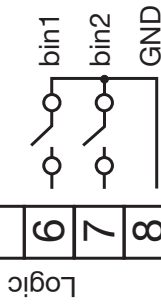
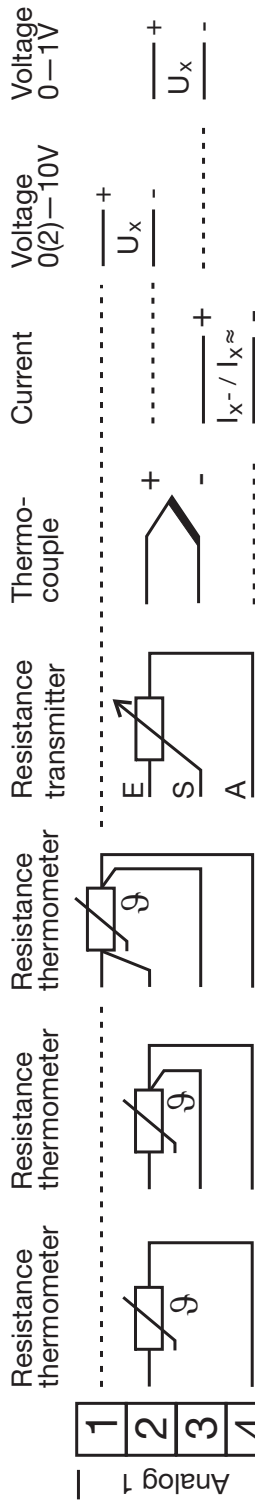

As an alternative to binary outputs 3 and 4 (configurable)!

Analog input 2 and binary inputs 3...6 - terminal strip 1 (option boards)

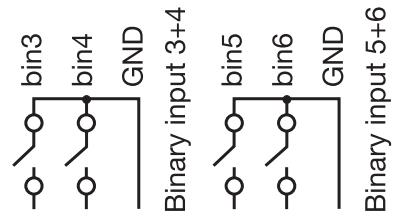
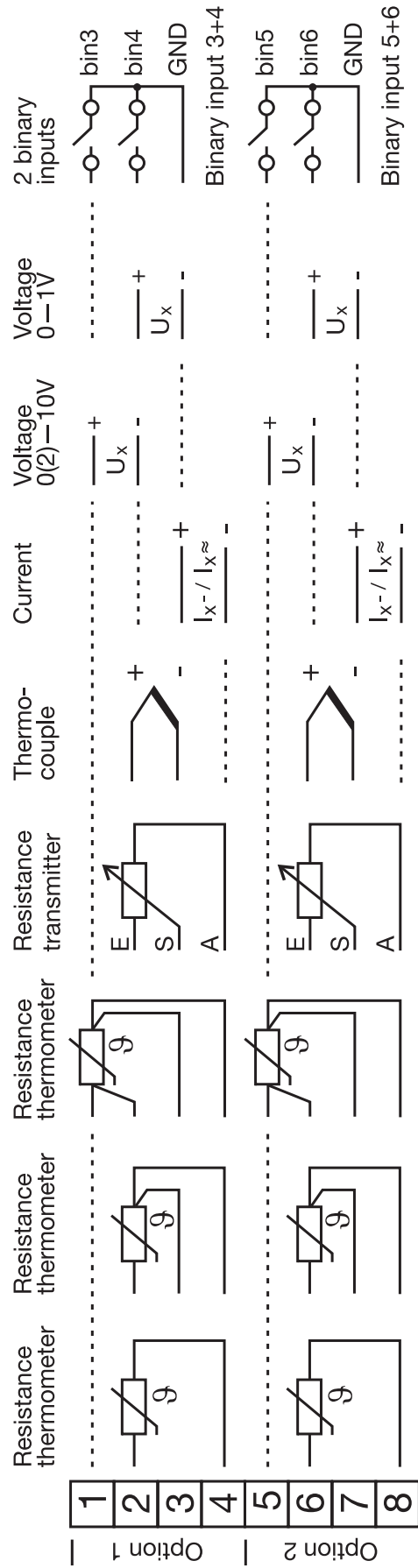

4 Electrical connection

4.3.2 Type 703046/48

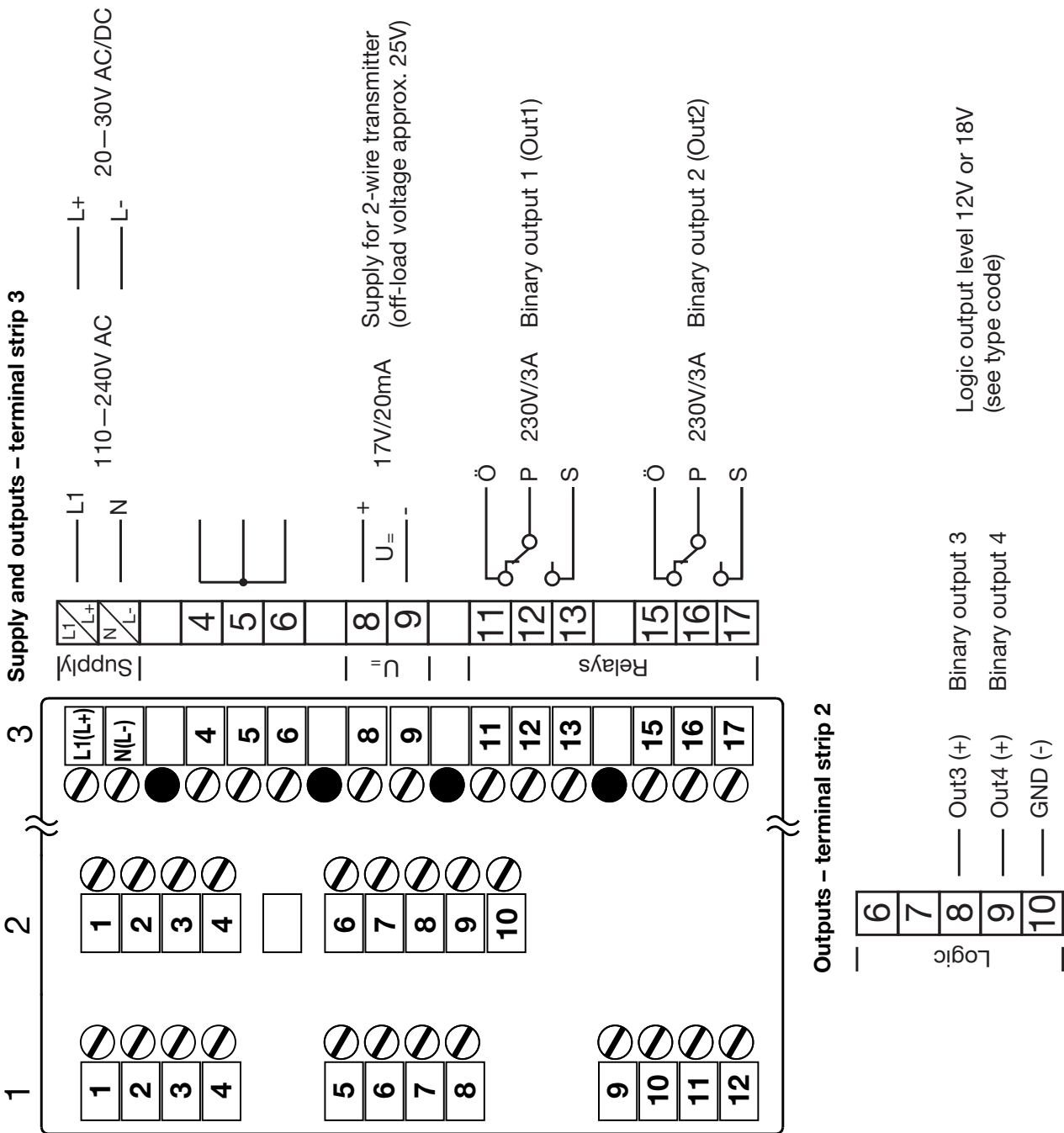

Type 703046/48 continued

Outputs and interfaces – terminal strip 1 (option boards)

Option	Analog output	Relay (changeover)	2 relays (n.o. make)	Solid-state relay	PROFIBUS	RS422	RS485	Current interface
Option 1	1
	2 + U _x /k -
	3 + U _x /k -
	4 + U _x /k -
Option 2	5 + U _x /k -
	6 + U _x /k -
	7 + U _x /k -
	8 + U _x /k -
Option 3	9 + U _x /k -
	10 + U _x /k -
	11 + U _x /k -
	12 + U _x /k -



Note numbering of outputs.

⇒ Chapter 8.5 “Outputs “OutP””

4 Electrical connection

Type 703046/48 continued

Analog input 1 and binary inputs 1+2 – terminal strip 2

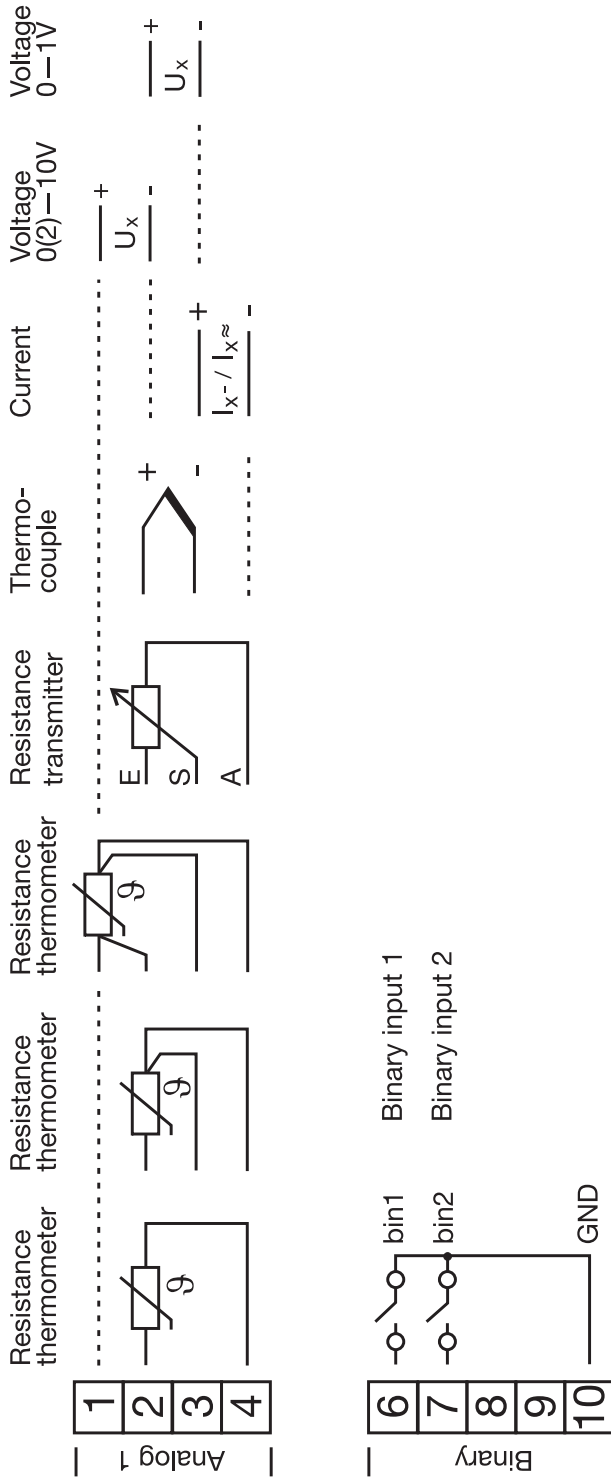

Type 703046/48 continued

Analog input 2 and binary inputs 3...8 – terminal strip 1 (option boards)

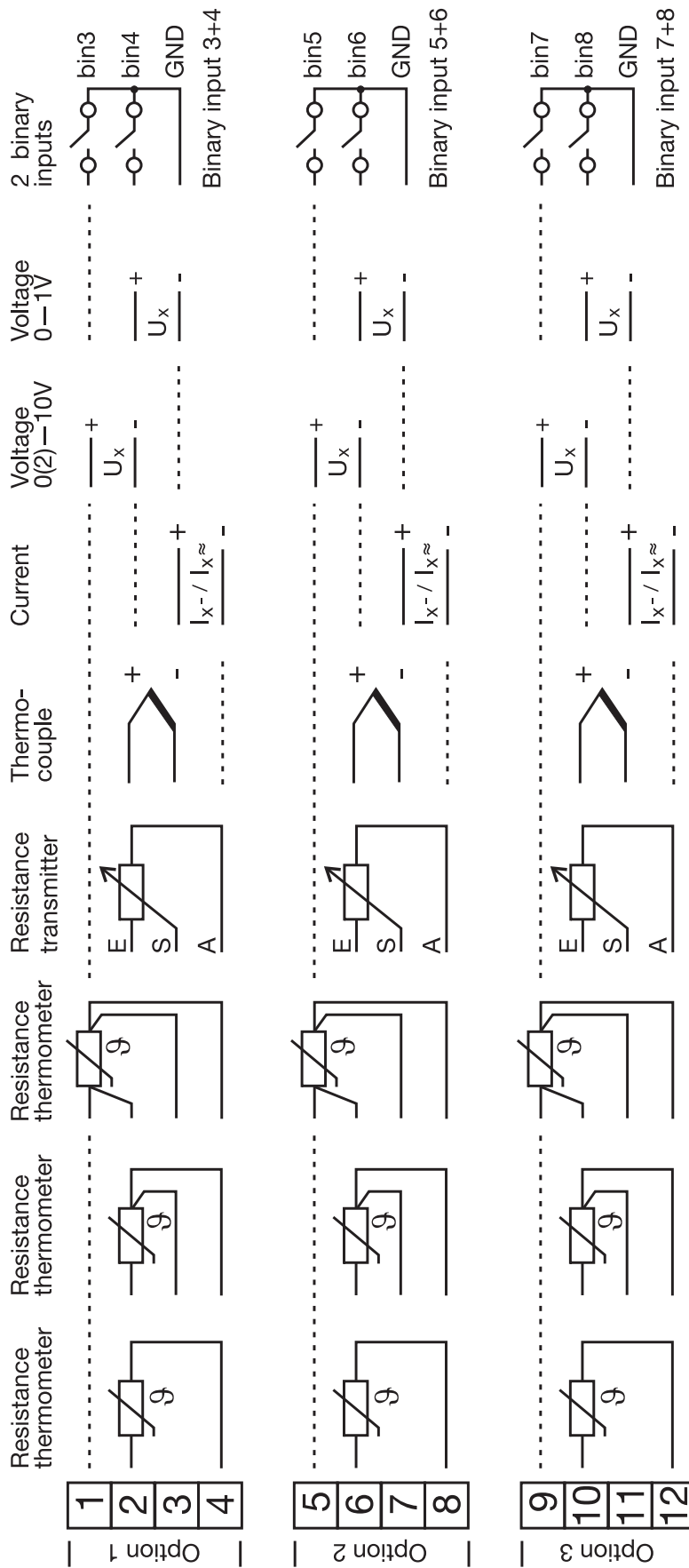

4 Electrical connection

4.3.3 Termination resistor for the RS422/485 serial interface

For fault-free operation of several devices in a line structure, their internal termination resistors must be activated at the start and end.

- * Pull plug-in module out towards the front by pressing on the knurled areas
- * Using a ballpoint pen, press all the white switches into the same direction

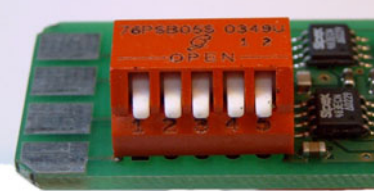
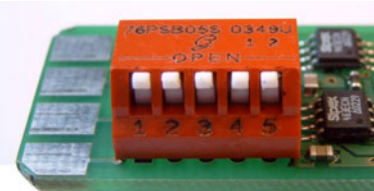
Bus termination resistor active:	<ul style="list-style-type: none"> * Push all 5 switches down 
No bus termination (ex-factory)	<ul style="list-style-type: none"> * Push all 5 switches up 

- * Re-insert the module back into the housing

Check

- * Press the **PGM** + **▲** keys

To the right of the green “VERs” display, “ON” is shown for active and “OFF” for inactive termination resistors.

4.3.4 Connection of the PROFIBUS-DP connector

Mounting the adapter

- * Identify option slot with the PROFIBUS-DP interface by means of the type code (in the case of pre-configured devices)

In this example, the PROFIBUS-DP interface is in option slot 1



To fit the D-SUB adapter, open the housing of the adapter; otherwise the terminal screws are hidden by the adapter.

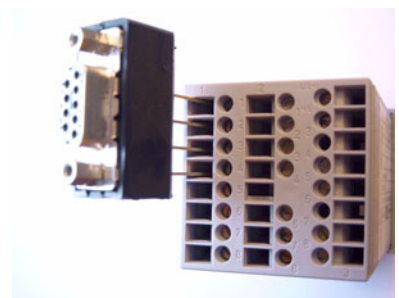

Assignment of the 9-pole D-SUB socket

Pin: Signal	Designation
1: VP	Supply voltage positive
2: RxD/TxD-P	Receive/Transmit data positive
3: RxD/TxD-N	Receive/Transmit data negative
4: DGND	Ground

5.1 Displays and controls



(1)	7-segment display (factory setting: process value) four-digit, red, decimal place is configurable (automatic adjustment on display overflow)
(2)	Active setpoint (factory setting: SP1) SP1, SP2, SP3, SP4 (SP=setpoint); green;
(3)	7-segment display (factory setting: setpoint) four-digit, green; decimal place is configurable; also used for operator prompting (display of parameter and level symbols)
(4)	Keys
(5)	Indication yellow, for - switch status of binary outputs 1 – 6 (display lights up = on) - ramp/program function is active - manual operation is active
(6)	16-segment display for the unit °C/°F and text two-digit, green; configurable; symbols for h, min, % In addition, the current segment number (program), the parameter set or any two-place letter/number combination can be displayed through the setup program.

The displays are configurable.

⇒ Chapter 8.7 “Display “diSP””

5 Operation

5.2 Level concept

The parameters for making the instrument settings are arranged at different levels.

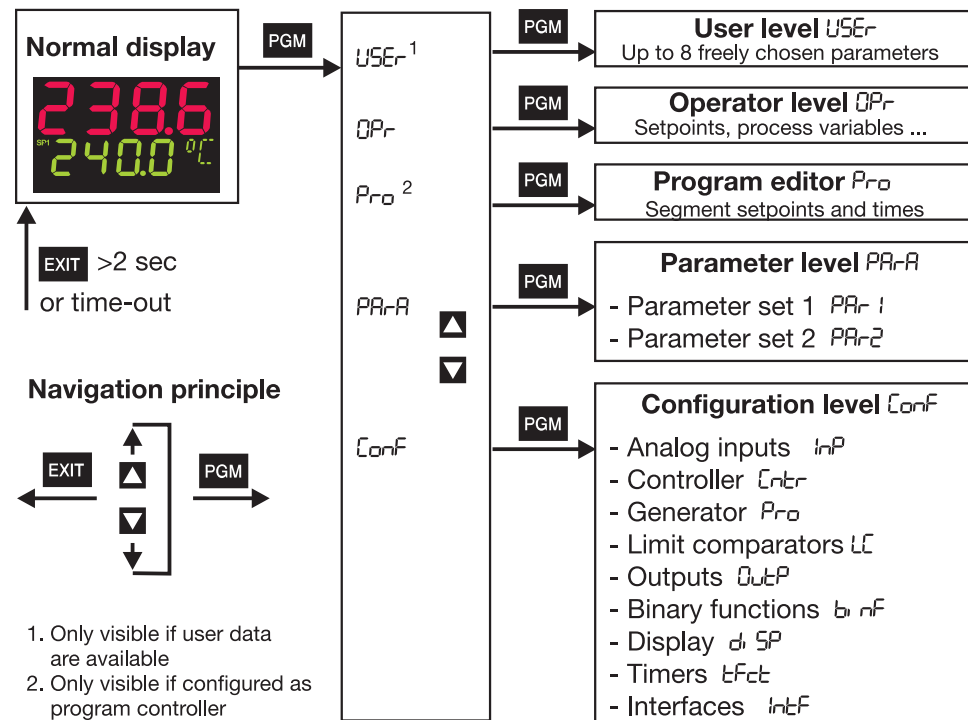

Time-out

If no key is pressed for 180 sec, the instrument returns to normal display.

- ⇒ Chapter 6 “Operator level”
- ⇒ Chapter 5.6.1 “Entering programs” (program editor)
- ⇒ Chapter 7 “Parameter level”
- ⇒ Chapter 8 “Configuration”
- ⇒ *Setup/Display - Operation/Time-out*

User level “USER”

The setup program can be used to display and edit up to 8 freely chosen parameters at this level.

- ⇒ Setup / Configuration level / Display - Operation / User data

The user can assign a symbol for the representation of each parameter. Otherwise the default symbol will be used. Permissible symbols are the letters and numbers that can be presented by a 7-segment display.

Factory settings:

Symbol	Meaning
rRSL	Ramp slope (warm-up ramp)
SPPA	Hold setpoint (warm-up ramp) =SPP2
tS	Dwell time (warm-up ramp) =tP2
YR	Output level limit (warm-up ramp)
SP 1	Setpoint 1
boSt	Boost value (-1999 to +9999 °C/°F or % of SP1)
SPLo	Reduced value (=SP2)

5.3 Level inhibit

Access to the individual levels can be prevented.

Code	Operator level, user level, program editor	Parameter level	Configuration level
0	enabled	enabled	enabled
1	enabled	enabled	inhibited
2	enabled	inhibited	inhibited
3	inhibited	inhibited	inhibited

- * Go to code entry with **PGM** and **▼** (simultaneously for >5sec).
- * Alter code with **PGM** (display blinks!)
- * Enter code with **▲** and **▼**. Ex-factory: all levels enabled.
- * Return to normal display with **EXIT** or automatically after approx. 180sec

The parameter and configuration levels can also be inhibited via the binary function.

⇒ Chapter 8.6 “Binary functions “binF””

5 Operation

5.4 Entries and operator prompting

Entering values

When entries are made within the levels, the parameter symbol is shown in the lower display.

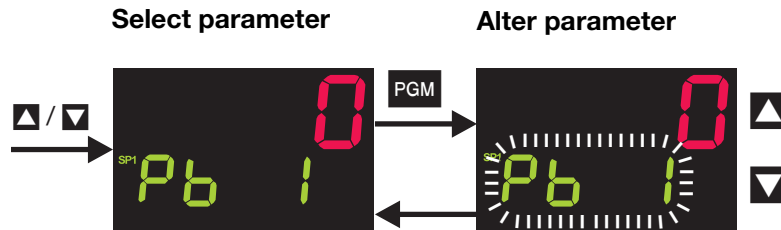

- * Select parameter with ▲ or ▼
- * Change to entry mode with PGM (lower display blinks!)
- * Alter value with ▲ and ▼
The value alters dynamically with the duration of the key stroke.
- * Accept the setting with PGM, or automatically after 2 sec
or
- * Cancel entry with EXIT.
The value is not accepted.

Entering times

When entering times (e.g. timer time), the time unit is shown in addition.

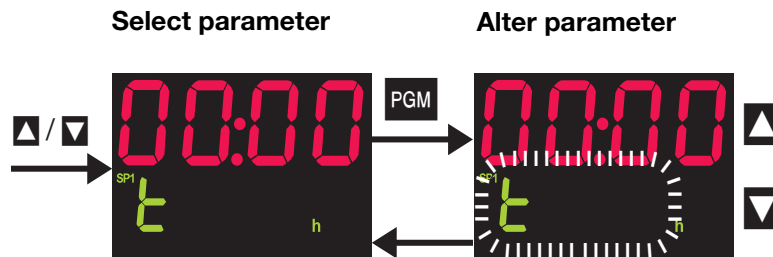

The highest time unit of the display is shown for the unit.

If, for instance, "h" is shown for the hour, then the time format for the value is hh:mm.

- * Select parameter with ▲ or ▼
- * Change over to the entry mode using PGM (lower display blinks!)
- * Alter value with ▲ and ▼
The value alters dynamically with the duration of the key stroke.
- * Accept the setting with PGM or automatically after 2 sec
or
- * Cancel entry with EXIT.
The value is not accepted.

5.5 Fixed-setpoint controller (ex-factory)

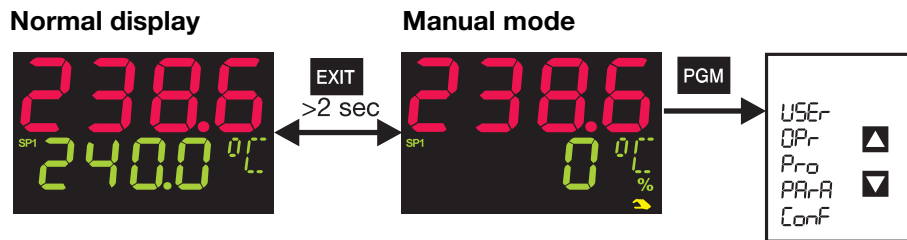

Altering the setpoint

In normal display:

- * Alter the present setpoint with ▲ and ▼ (the value is accepted automatically)

Manual mode

In manual mode, the controller output can be altered by hand.

- * Change to manual mode with EXIT (> 2 sec)

The output appears in the lower display. The hand symbol and the unit “%” light up in addition.

- * Alter the output with ▲ and ▼

In the case of a modulating controller, the actuator is opened or closed using the keys.

The various levels can be accessed from the manual mode.

- * Finish manual mode with EXIT (>2 sec)

The output entry on a changeover is configurable. The manual mode can be inhibited.

⇒ Chapter 8.2 “Controller “Cntr””

Additional operating options for the fixed-setpoint controller can be implemented via the binary functions.

⇒ Chapter 8.6 “Binary functions “binF””

On overrange/underrange and probe break, the controller automatically changes over to manual mode.

5 Operation

5.6 Program controller

Condition as delivered The instrument must be configured as a program controller/generator. Furthermore, a program must be entered beforehand, to operate the instrument as a program controller/generator.

5.6.1 Entering programs

Function A setpoint profile can be implemented with a maximum of 8 program segments.

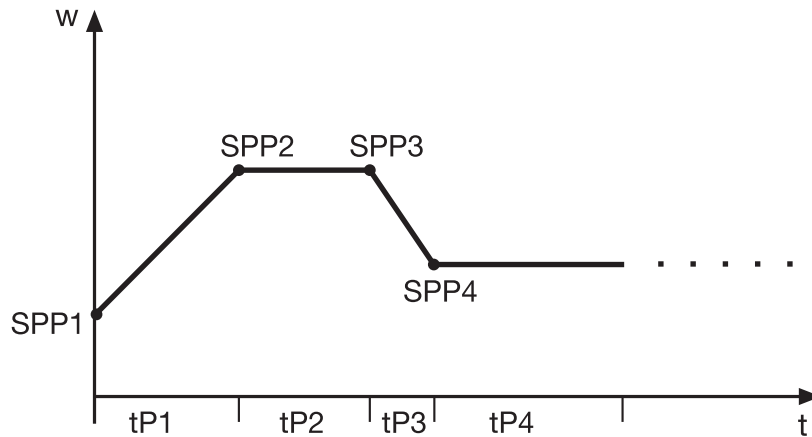

Entry on the instrument The instrument must be configured as a program controller/generator.
 ⇒ Chapter 8.3 “Generator “Pro”” (Function)
 Configurable time base: mm:ss, hh:mm und dd:hh (s=seconds, m=minutes, h=hours, d=days).
 ⇒ Chapter 8.3 “Generator “Pro”” (unit)
 The segment setpoints (SPP1 – SPP8) and segment times (tP1 – tP8) are set in the program editor.

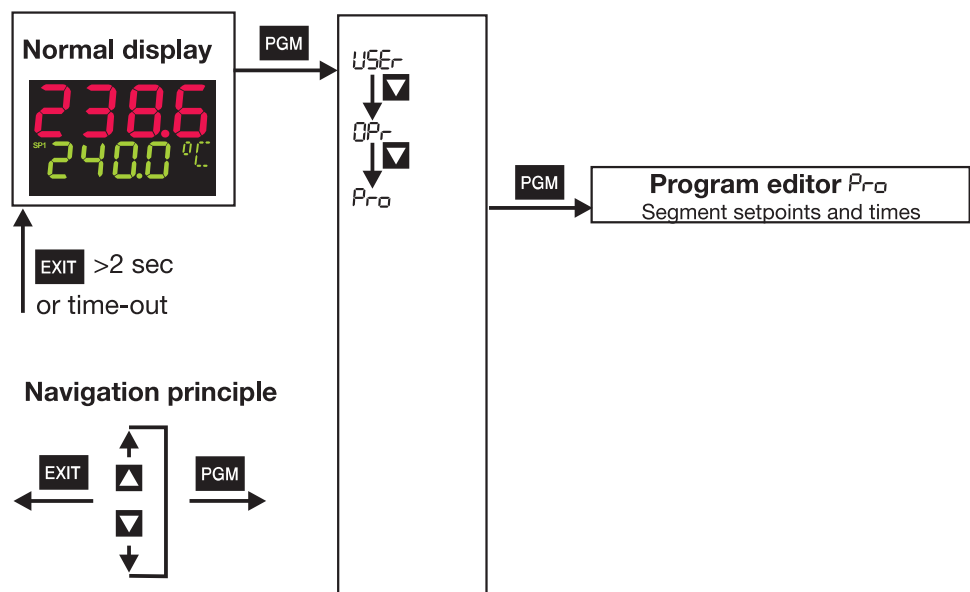

5 Operation

The program segments (up to eight) are defined by the segment setpoint and the segment time.

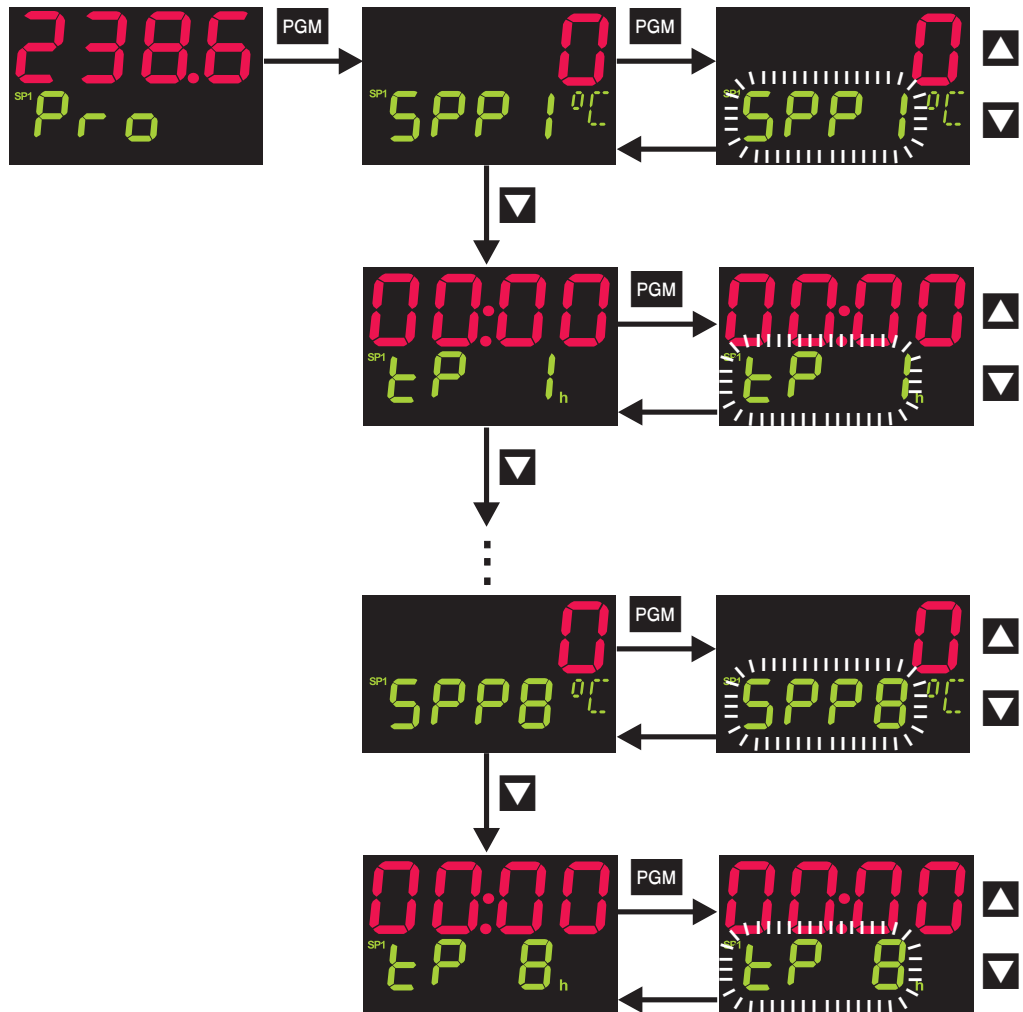

Entry through setup program

The setup program (accessory) features a user-friendly program editor, with a graphical presentation of the program profile.

Additional functions via the setup program

- Start at the process value
- Response to over/underrange
- Repeat program
- Setpoint input (ramp/step)
- Process is controlled to the most recent setpoint
- Delay time
- Program editor/management with graphical preview
- Up to four control contacts can be programmed segment by segment
- Parameter sets can be assigned segment by segment

5 Operation

5.6.2 Operation

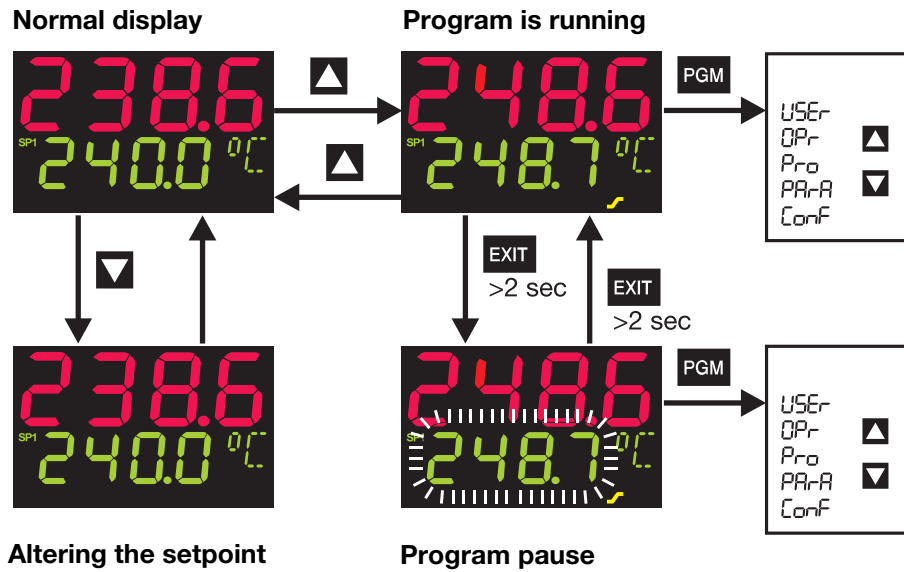

Normal display

No program run in normal display, the controller controls to the selected setpoint.

Altering the setpoint

From normal display:

- * Change to setpoint input with **▼**
- * Alter the present setpoint with **▲** and **▼** (the value is accepted automatically)

Starting the program

From normal display:

- * Start program with **▲** (the ramp symbol lights up!)

A delay time can be configured through the setup program. When the delay time has elapsed, "EXIT" is shown in the lower display, and then the program is processed.

Canceling the program

When the program is running:

- * Cancel program with **▲**

Pausing the program

When the program is running:

- * Pause program with **EXIT** (>2 sec) (the lower display blinks!)
- * Continue with **EXIT** (>2 sec)

The program is canceled in the event of a power failure.

Additional program control functions via binary functions.

⇒ Chapter 8.6 "Binary functions "binF"

5.6.3 Shifting the program profile

The function “External setpoint with correction” can be used to shift the program profile upwards or downwards (configurable through the setup program only).

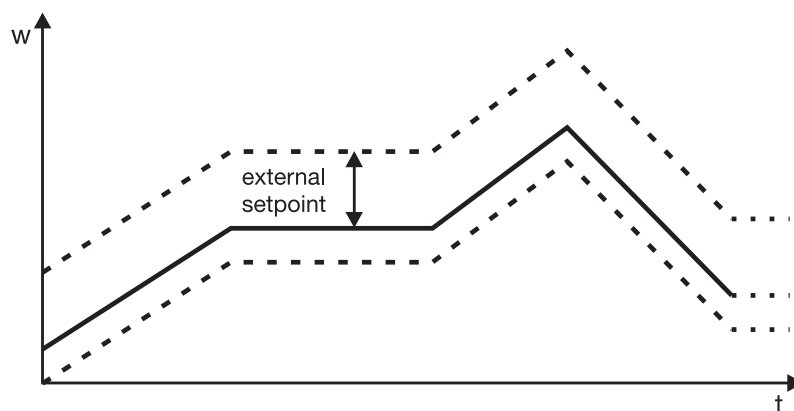

The external setpoint is defined via an analog signal.

⇒ Chapter 8.2 “Controller “Cntr””

5 Operation

6 Operator level

Access

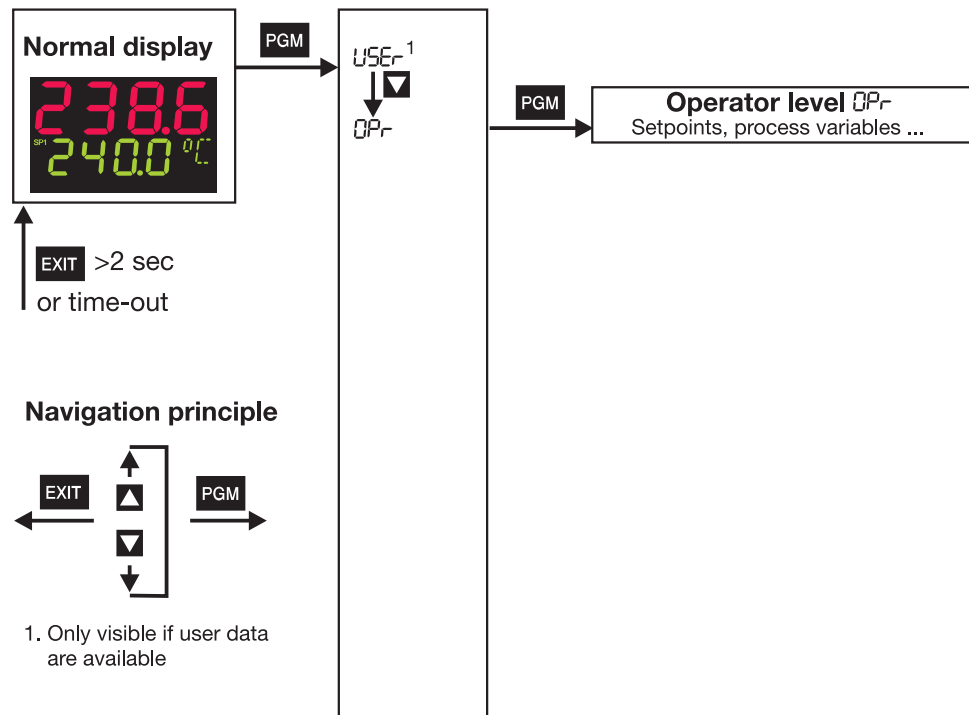

Process data

The four setpoints are displayed and edited here, and additional process variables are shown in accordance with the configuration.

Symbol	Meaning
SP 1	Setpoint 1 (editable)
SP 2	Setpoint 2 (editable)
SP 3	Setpoint 3 (editable)
SP 4	Setpoint 4 (editable)
SP_r	Ramp setpoint (only if configured)
INP 1	Measurement of analog input 1
INP 2	Measurement of analog input 2 (only if available)
F 1	Calculated result of math formula 1 (and for difference, ratio and humidity controller)
F 2	Calculated result of math formula 2 (only if available)
Y	Controller output
t_run	Program run time (only with program controller/generator)
t_RES	Residual program time (only with program controller/generator)
t 1	Timer run time 1 (only if configured)
t 2	Timer run time 2 (only if configured)

6 Operator level

Definition of the program times

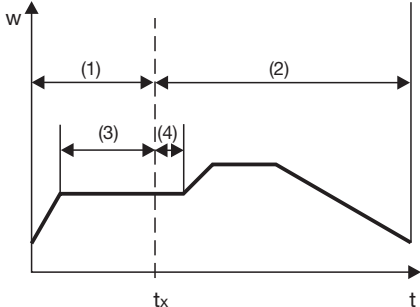

(1) Program run time	(3) Segment run time
(2) Residual program time	(4) Residual segment time

7 Parameter level

General

Two parameter sets (PAR1 and PAR2) can be stored.

Access

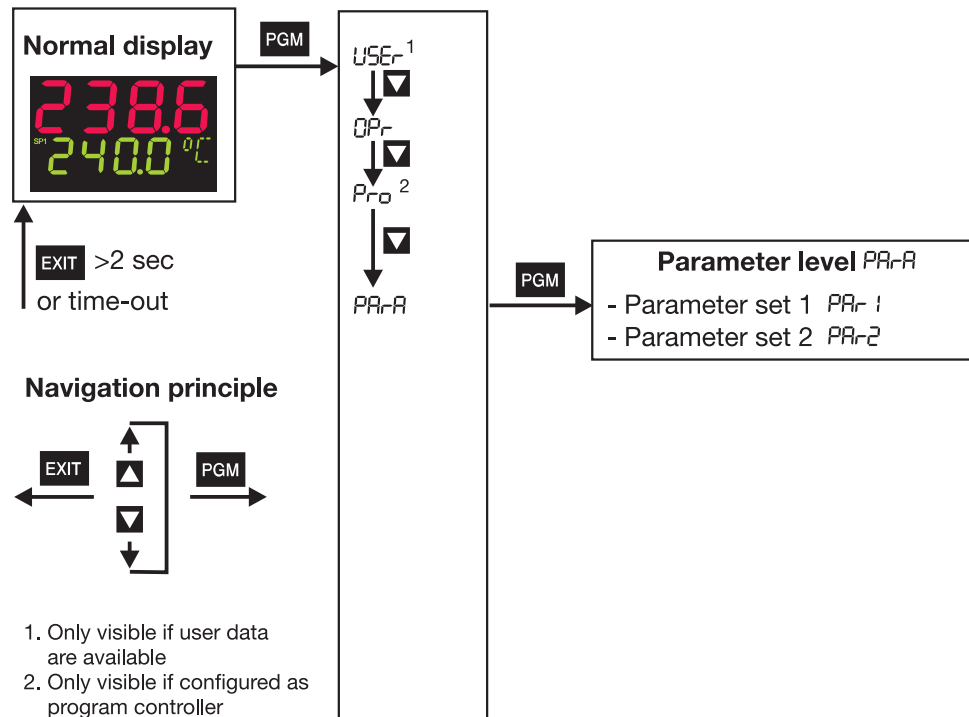

The level can be inhibited.

Applications

- Parameter set switching via binary function
⇒ Chapter 8.6 “Binary functions “binF””
- Allocating parameter sets to program segments (only through the setup program)
⇒ *Program editor/Program*

Example

Setting a 2-state controller with PI action:

Pb1=12°C (proportional band)
rt=160sec (reset time; I component)
dt=0sec (derivative time, D component)

7 Parameter level

PARA → PAR 1 (PAR 2)

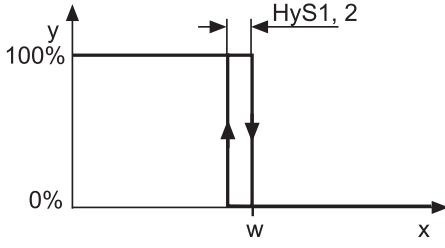
	Display	Value range	Factory setting	Description
Proportional band	Pb 1	0...9999	0	Size of the proportional band The gain of the controller decreases with increasing proportional band. With Pb 1,2 = 0 the controller structure is ineffective (limit comparator response). Continuous controllers: Pb1,2 must be >0.
	Pb 2	0...9999	0	
Derivative time	dt 1	0...9999 s	80 s	Influences the differential component of the controller output signal. The effect of the D component increases with increasing derivative time.
	dt 2	0...9999 s	80 s	
Reset time	rt 1	0...9999 s	350 s	Influences the integral component of the controller output signal. The effect of the I component decreases with increasing reset time.
	rt 2	0...9999 s	350 s	
Cycle time	Cy 1	0.0...999.9s	20 s	With a switched output, the cycle time should be chosen so that a) the pulsed energy flow to the process does not cause any impermissible PV fluctuations and b) the switching elements are not overloaded.
	Cy 2	0.0...999.9 s	20 s	
Contact spacing (dead band)	db	0.0...999.9	0	The spacing between the two control contacts for 3-state or modulating controllers.
Switching differential	HyS 1	0.0...999.9	1	Hysteresis for switching controllers with Pb1,2 = 0. 
	HyS 2	0.0...999.9	1	
Actuator time	tt	5...3000 s	60 s	Actuator time range used by the control valve for modulating controllers.
Working point	Y0	-100...+100%	0%	Output for P and PD controllers (when x = w then y = Y0).
Output limiting	Y 1	0...100%	100%	Maximum output limiting.
	Y 2	-100...+100 %	-100%	Minimum output limiting. (only effective with PB>0!)

The parameters Pb2, dt2, rt2, Cy2 and HyS2 refer to the second controller output for a 3-state controller.

The decimal place of some parameters depends on the decimal place setting in the displays.



The parameter display on the instrument depends on the controller type selected.

⇒ Chapter 8.2 “Controller “Cntr””

8 Configuration

General

The following applies to the representation of parameters and functions at the configuration level:

The parameter is not displayed or can not be selected if

- the equipment level does not permit the function assigned to the parameter.

Example: Analog output 2 can not be configured if analog output 2 is not implemented in the instrument.

 Some parameters can only be programmed through the setup program. These are marked in the symbol column with “(setup)”.

The symbol (appears in the display) that corresponds to the menu item is shown in the chapter headings (e.g. 8.1 Analog inputs “InP”).

Access

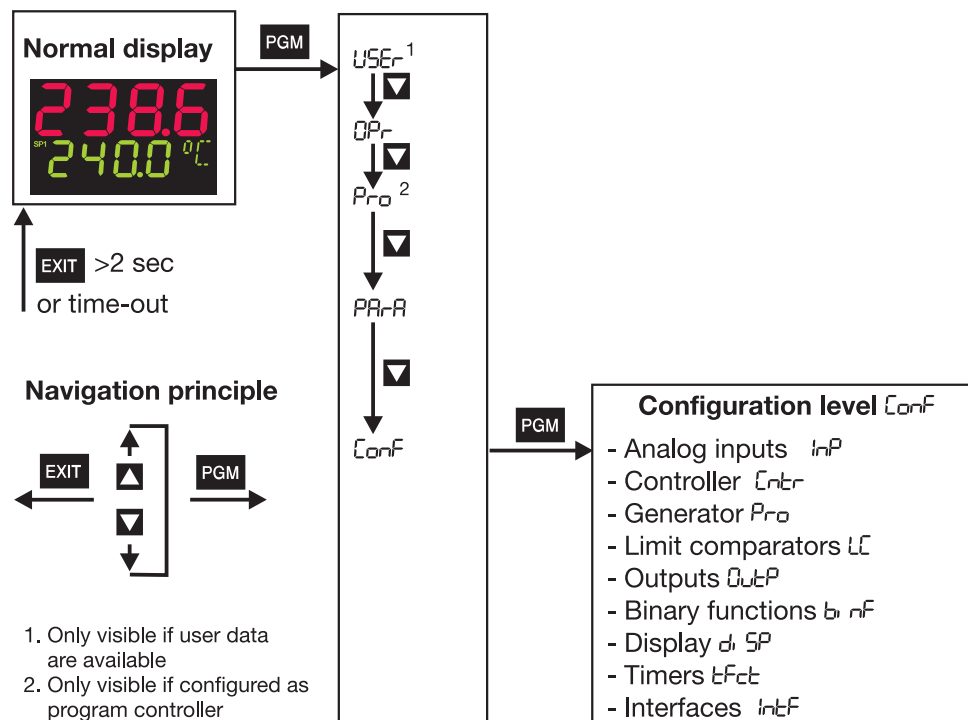

 Levels can be inhibited.

⇒ Chapter 5.3 “Level inhibit”

8 Configuration

Analog selector

With some parameters, you can choose from a series of analog values. To provide you with an overview, this selection is listed below.

- | | |
|----------------------------|---|
| 0 no function | 21 program run time in sec |
| 1 analog input 1 | 22 residual program time in sec |
| 2 analog input 2 | 23 segment run time in sec |
| 3 process value | 24 residual segment time in sec |
| 4 present setpoint | 25 timer run time for timer 1 in sec |
| 5 ramp end value | 26 timer run time for timer 2 in sec |
| 6 program setpoint | 27 residual run time for timer 1 in sec |
| 7 math 1 | 28 residual run time for timer 2 in sec |
| 8 math 2 | 29 present segment end value |
| 9 setpoint 1 | 30 analog marker (Profibus) |
| 10 setpoint 2 | 31 reserved |
| 13 controller output level | 32 reserved |
| 14 controller output 1 | 33 reserved |
| 15 controller output 2 | |

Definition of the program times

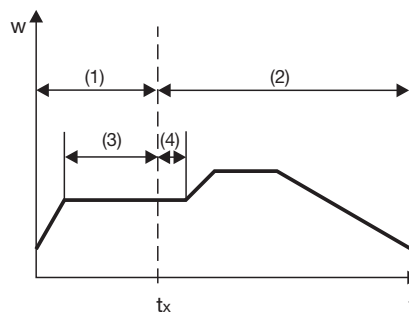

(1) Program run time	(3) Segment run time
(2) Residual program time	(4) Residual segment time

8.1 Analog inputs “InP”

Configuration
Analog inputs
Controller
Generator
Limit comparators
Outputs
Binary functions
Display
Timer
Interfaces

InP: Analog input

Depending on the instrument version, up to two analog inputs are available.

Analog input 1 InP1 →



Analog input 2 InP2 →

	Symbol	Value/selection	Description
Sensor type	SEN5	0 1 2 3 4 5 6 7 8 9 10 11	no function Resistance thermometer in 3-wire circuit Resistance thermometer in 2-wire circuit Resistance thermometer in 4-wire circuit Thermocouple Resistance transmitter Heater current 0 – 50mA AC (analog input 2 only) 0 – 20mA (see also “Heater current monitoring”) 4 – 20mA 0 – 10V 2 – 10V 0 – 1V
			factory-set on analog input 2: no function
Linearization	Lin	0 1 2 3 4 5 6 7 8 9 10 11 12 13 14 15 16 17 18	Linear Pt100 Pt500 Pt1000 KTY11-6 W5Re_W26Re C W3Re_W25Re D NiCr-Con E Cu-Con T Fe-Con J Cu-Con U Fe-Con L NiCr-Ni K Pt10Rh-Pt S Pt13Rh-Pt R Pt30Rh-Pt6Rh B NiCrSi-NiSi N W3Re_W26Re customized linearization
			For customized linearization, a maximum of 10 knee-points can be implemented, or a 5th order polynomial function programmed (only through the setup program). For the linearization “KTY11-6”, the resistance is 2kΩ at 25°C (only through the setup program).

Factory settings are shown **bold**.

8 Configuration

Analog input 1 $INP1 \rightarrow$
 Analog input 2 $INP2 \rightarrow$

	Symbol	Value/selection	Description									
Measurement offset	OFF5	-1999... 0 ... +9999	<p>The measurement offset is used to correct a measured value by a certain amount upwards or downwards.</p> <p>Examples:</p> <table border="1"> <thead> <tr> <th>Measured value</th> <th>offset</th> <th>Displayed value</th> </tr> </thead> <tbody> <tr> <td>294.7</td> <td>+0.3</td> <td>295.0</td> </tr> <tr> <td>295.3</td> <td>- 0.3</td> <td>295.0</td> </tr> </tbody> </table> <p> The controller uses the corrected value (= displayed value) for its calculation. This value is not the same as the actually measured value. If incorrectly applied, this can result in impermissible values of the control variable.</p> <p>Special case: 2-wire circuit If the input is connected to a resistance thermometer in 2-wire circuit, then the lead resistance is set in ohms here.</p>	Measured value	offset	Displayed value	294.7	+0.3	295.0	295.3	- 0.3	295.0
Measured value	offset	Displayed value										
294.7	+0.3	295.0										
295.3	- 0.3	295.0										
Display start	5CL	-1999... 0 ...+9999	On transducers with standard signal and on potentiometers, a display value is assigned to the physical signal.									
Display end	5CH	-1999... 100 ...+9999	<p>Example: 0 – 20mA = 0 – 1500°C.</p> <p>The range of the physical signal can be 20 % wider or narrower without generating an out-of-range signal.</p>									
Filter time constant	dF	0... 0.6 ... 100 s	<p>To adjust the digital input filter (0sec = filter off). 63% of the alterations are acquired after 2x filter time constant at a signal step change.</p> <p>When the filter time constant is large:</p> <ul style="list-style-type: none"> - high damping of disturbance signals - slow reaction of the process value display to process value changes - low limit-frequency (2nd order low-pass filter) 									
Fine tuning start value	FES¹	-1999... 0 ...+9999	<p>⇒ see “Customized fine tuning” on Page 45</p> <p> If these values are altered by mistake, then this setting has to be canceled, using the procedure described under “Customized fine tuning”. These values can not be accepted by another instrument.</p>									
Fine tuning end value	FEE¹	-1999... 1 ... +9999										

1. Both parameters can be activated/deactivated with setup program.

Factory settings are shown **bold**.

8 Configuration

Analog input 1 InP 1 →
 Analog input 2 InP 2 →

Heater current monitoring (output)

Symbol	Value/selection	Description
HEAT	0 1...10	<p>No function Binary output 1 – 10 (controller output)</p> <p>The heater current is measured via a current transformer with standard signal output and can be monitored by linking analog output 2 to limit comparator 1. The input signal range is 0 – 50mA AC (see probe type: “Heater current”) and must be scaled accordingly (display start/end). The heater current is measured when the heating contact is closed. For this purpose, the binary output which controls the heater contact (not the binary output for the alarm) has to be selected here. If the heater contact is opened, then the leakage current is measured after an adjustable delay (switch-off delay for limit comparator 1). Example: Switch-off delay: 5 sec Switch-on delay: 1 sec</p> <p>The heater current can be monitored by limit comparator 1 for exceeding or falling below a limit (functions lk7 and lk8). When heater current monitoring is configured, the leakage current will be monitored at the same time. This is done internally, through a limit comparator with an lk7 function, a switching differential of 0, and a limit that corresponds to 1 % of the limit for limit comparator 1. The output signal is also produced via the output of limit comparator 1.</p> <p>When using a current transformer with signal output DC 0 to 20 mA:</p> <ol style="list-style-type: none"> 1. Setup only – Undocumented parameters: Activate parameter 7. 2. Analog input 2 – Sensor type: Select “Heater current”. 3. Analog input 2 – Heater current monitoring: Select the relevant output. 4. Analog input 2 – Sensor type: Select „0 - 20 mA“ (the setting under “Heater current monitoring” becomes invisible, but is still active).
KTY correction at 25°C	(setup) 0... 2000 ...4000 Ω	Resistance at 25°C/77°F for linearization “KTY 11-6”

Factory settings are shown **bold**.

8 Configuration

Analog inputs (general) in 12 →

	Symbol	Value/selection	Description
Temperature unit	Unit	0 1	deg. Celsius deg. Fahrenheit Unit for temperature values
Sampling cycle time	Cycle	0 1 2 3	50msec 90msec 150msec 250msec
Supply frequency	(setup)	50Hz 60Hz	Adaptation of the conversion time of the input circuitry to the supply frequency

Factory settings are shown **bold**.

8.1.1 Customized fine tuning

Activate FtS and FtE with setup program

Ex-factory, both parameters are not visible at the device and have to be activated first.

- * Connect the device to the PC and start the setup program
- * Establish a connection to the device
- * Make a double click on *Undocumented parameters*

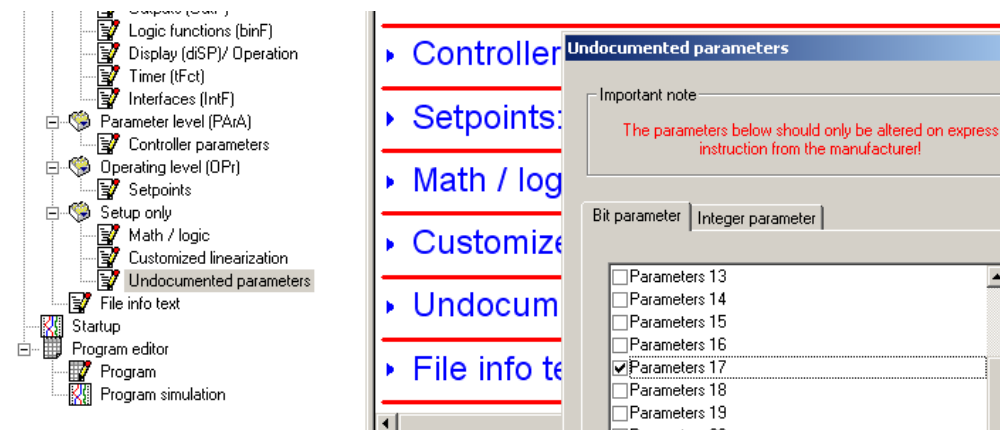

- * Click on check box at *Parameter 17* (a tick shall appear)
- * Save the setup file and execute *Data transfer to device*

Now the parameters FtS and FtE are visible in the Configuration level.

Principle

The customised fine tuning (= fine adjustment) is used to correct the values displayed by the device. This may be necessary, for example, after a system validation, if the displayed values no longer coincide with the actual values at the point where the measurement is taken.

Using a reference measuring instrument, two measured values are determined which should be as far apart as possible (start value, end value). Ensure that the measuring conditions are stable. Enter the reference value found as the start value (FtS) or end value (FtE) on the device to be adjusted.



Caution:

If start value and/or end value deviate from the factory-set values (FtS=0 and FtE=1), a fine adjustment has already been done before. In this case the fine adjustment has to be reset (see below).

Repeating fine adjustment without doing a reset before means that an already adjusted characteristic curve is used. This leads to wrong values.

8 Configuration

Example

The temperature inside an oven is measured with a resistance thermometer and displayed on a device. The reading on the device deviates from the actual temperature as a result of the sensor temperature drifting. At 20°C the device reads 15°C, at 80°C it shows 70°C (exaggerated example for better understanding).

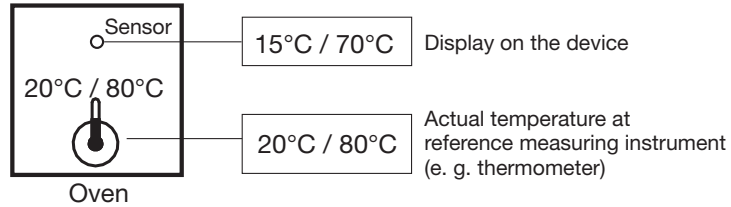

Procedure

- * Determine lower measurement value (as low as possible and constant) with a reference measuring instrument;
Example: Oven temperature 20°C (= room temperature)
- * Set start value at the device to this lower measurement value;
Example: Set start value (FtS) to 20
- * Increase temperature and determine higher measurement value (as high as possible and constant) with reference measuring instrument;
Example: Increase oven temperature to 80°C
- * Set end value at the device to this higher measurement value;
Example: Set end value (FtE) to 80

Characteristic curve

The following diagram shows the changes in the characteristic curve caused by the fine adjustment (point of intersection with the x axis as well as ascent)

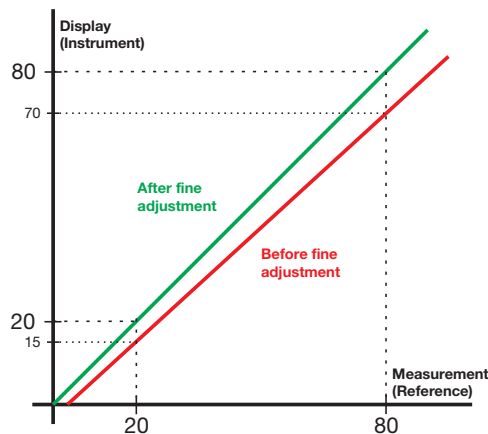

Special case: Offset

If the deviation between measured value and displayed value at the low and high measuring point is identical, an offset correction is sufficient (ascent remains unchanged). In this case, fine adjustment is not required.

⇒ Chapter 8.1 “Analog inputs “InP””
Parameter OFFS

Reset fine adjustment

In order to reset fine adjustment, the same value has to be given to start value (FtS) and end value (FtE) (e. g. set both parameters to 0). This automatically sets the start value to 0 and the end value to 1 (factory setting).

8.2 Controller “Cntr”

Configuration
Analog inputs
Controller
Generator
Limit comparators
Outputs
Binary functions
Display
Timer
Interfaces

Cntr: Controller

The following are set here: controller type, input variables of the controller, the setpoint limits, conditions for manual mode and the presettings for self-tuning (self-optimization).

Symbol	Value/selection	Description
Configuration		
Controller type	CTYP	0 no function 1 2-state controller 2 3-state controller 3 Modulating controller 4 Continuous controller
Control action	CACT	0 Direct 1 Inverse <p>inverse: The controller output Y is > 0 when the process value is smaller than the setpoint (e. g. heating).</p> <p>direct: The controller output Y is > 0 when the process value is larger than the setpoint (e. g. cooling).</p>
Inhibit manual mode	INH	0 enabled 1 inhibited If the manual mode is inhibited, changing over to “manual” is not possible from the keys or via the binary input.
Manual output	HAND	-100... 101 Defines the controller output level after changing over to manual mode. 101 = last output For modulating controller: 101 = actuator is stationary; 0 = actuator closes; 100 = actuator opens
Range output	ROUT	-100... 0 ...101 Output on over/underrange. 101 = last output For modulating controller: 101 = actuator is stationary; 0 = actuator closes; 100 = actuator opens
Setpoint low	SPL	-1999 ...+9999 Setpoint limiting prevents the input of values outside the defined range.
Setpoint high	SPH	-1999 ... +9999  The setpoint limits are not effective with setpoint input via the interface. The correction value is limited for external setpoint with correction.

Factory settings are shown **bold**.

8 Configuration

	Symbol	Value/selection	Description
Inputs			
Controller process value	\overline{CPr}	(analog selector) Analog inp. 1	Defines the source for the process value of the control channel.
External setpoint	\overline{ESP}	(analog selector) switched off	Activates the external setpoint input and defines the source for the external setpoint. External setpoint with correction: External setpoint + setpoint 1 = present setpoint The external setpoint is corrected up or down from the keypad (setpoint 1). The display shows the present setpoint.
Output feedback	\overline{FEEd}	(analog selector) switched off	Defines the source for output feedback for a modulating controller. ⇒ see “Analog selector” on Page 40
Self-tuning			
Method of tuning	\overline{tYPt}	0 1	Oscillation method Step response method ⇒ Chapter 9.1 “Self-tuning (self-optimization)”
Inhibit tuning	\overline{InHt}	0 1	enabled inhibited If self-tuning is inhibited, it can not be started via the keys or the binary function.
Output of tuning 1	$\overline{Ott1}$	0 1	Relay Solid-state + logic Continuous The type of the physical output for the signal of the controller outputs 1 and 2 has to be defined.
Output of tuning 2	$\overline{Ott2}$	2	
Controller standby output	\overline{SOUt}	-100... 0 ...+100 %	Initial output with step response
Step size	$\overline{StS1}$	10... 30 ... 100 %	Step size with step response
Boost function			
Boost function	\overline{Fctb}	0 1 2	inactive Value in °C Value in %
Boost value	\overline{boSt}	-1999... 0 ...+9999	in °C or % ⇒ see “Boost function” on Page 54
Control loop monitoring			
Control loop monitoring	\overline{InHc}	0 1	inactive active
Response time	\overline{tC}	0 ...9999s	0: tr=rt (reset time) ⇒ see “Control loop monitoring” on Page 50
Monitoring band	\overline{toLc}	0 ...1999	0: toLr=0.5*Pb (proportional band) ⇒ see “Control loop monitoring” on Page 50
Output level monitoring			
Output level monitoring	\overline{InHy}	0 1	inactive active
Determination time	\overline{tY}	0 ... 350 ...9999s	⇒ see “Output level monitoring” on Page 52
Monitoring band	\overline{toLY}	0 ... 10 ... 100 %	⇒ see “Output level monitoring” on Page 52
Alarm trigger delay	\overline{tOnY}	0 ...9999s	⇒ see “Output level monitoring” on Page 52
Control difference band	$\overline{d, Fb}$	0 ... 1 ... 1999	⇒ see “Output level monitoring” on Page 52

Factory settings are shown **bold**.

8 Configuration

Analog selector

0	no function	21	program run time in sec
1	analog input 1	22	residual program time in sec
2	analog input 2	23	segment run time in sec
3	process value	24	residual segment time in sec
4	present setpoint	25	timer run time for timer 1 in sec
5	ramp end value	26	timer run time for timer 2 in sec
6	program setpoint	27	residual run time for timer 1 in sec
7	math 1	28	residual run time for timer 2 in sec
8	math 2	29	present segment end value
9	setpoint 1	30	analog marker (Profibus)
10	setpoint 2	31	reserved
13	controller output level	32	reserved
14	controller output 1	33	reserved
15	controller output 2		

8 Configuration

Control loop monitoring

This function is used to monitor the approach behavior when a system starts up and after setpoint step changes. An alarm is triggered if the process value does not respond to the setpoint signals in accordance with the parameters.

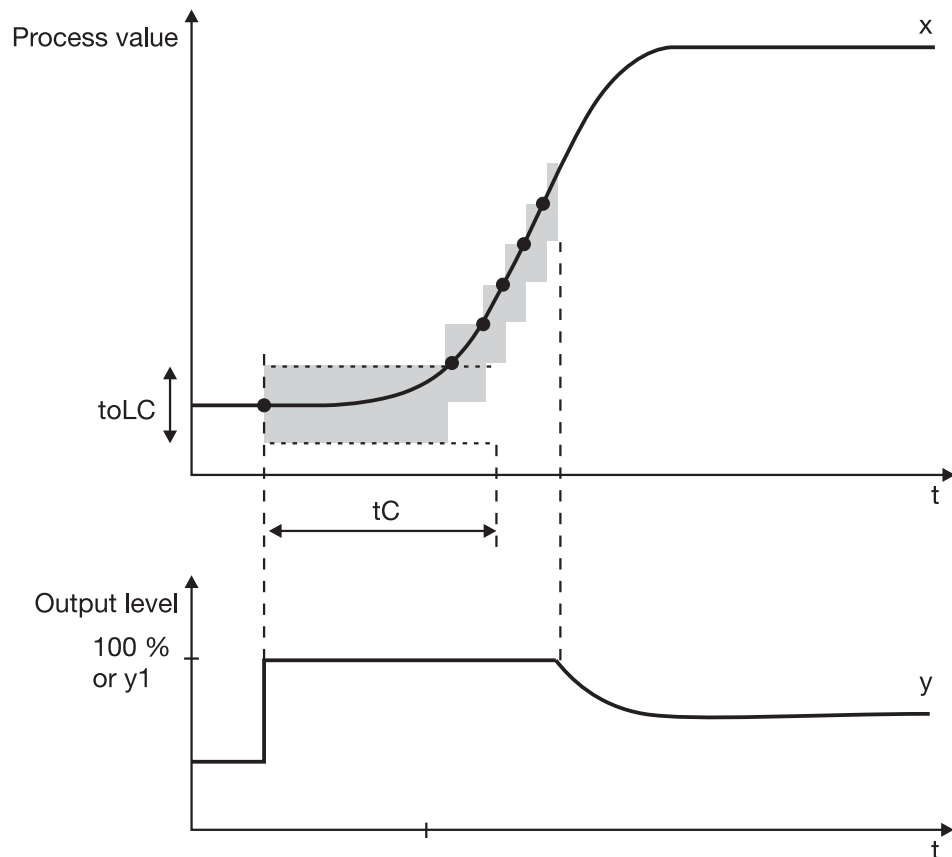

The change of the process value in response to setpoint changes is checked. If the maximum output level is produced (for heating: 100 % or the maximum output level y_1 ; for cooling: -100 % or the minimum output level limit y_2) then the adjustable response time t_C starts to run. If the system is operating correctly, the process value will move outside the monitoring band $toLC$ within this period. When the value leaves the monitoring band, the present process value is taken as the reference point for a new monitoring band. This procedure is repeated as long as the maximum output level is being produced.

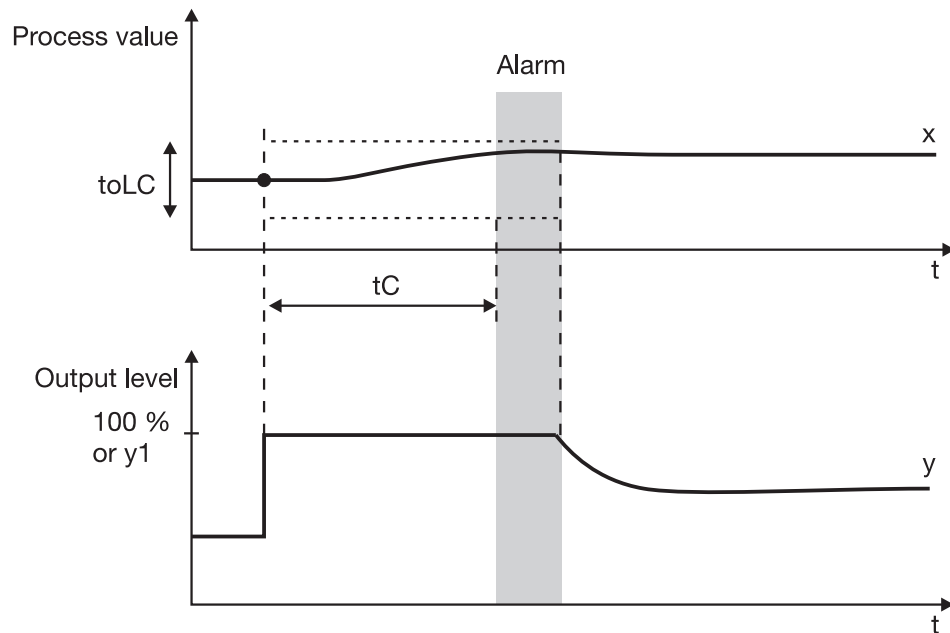

If the process value does not move outside the adjustable monitoring band $toLC$ within this period, then an alarm signal is generated. The alarm signal is maintained as long as the maximum output level is being produced and the process value is still within the monitoring band.

Possible causes of an alarm:

- Partial or total failure of a heater element or elements or other components
- Wrong direction of control action (e.g. heating on \rightarrow process value falls)

The control loop monitoring is inactive under the following conditions:

- during self-tuning
- in manual mode
- if the controller output level is not at one of the output level limits.



Special case: modulating controller without output level feedback

In this case, the actuator stroke time t_t is added to the response time t_C , to ensure that the actuator has time to be fully opened. The actuator must be activated for the entire t_t time.

Notes on configuration

The controller parameters (parameter level) for the instrument must have optimum settings. If necessary, run the self-tuning.

If brief alarms occur, even though the system is operating correctly, then either the response time must be lengthened or the monitoring band must be made narrower. Before doing this, record the approach curve (using the startup function of the setup program, for instance).

If the alarm signal is to be given out by an output, then the corresponding output must be configured for "Control loop monitoring".

\Rightarrow Chapter 8.5 "Outputs "OutP""

Additional functions:

\Rightarrow Chapter 8.6 "Binary functions "binF""

8 Configuration

Output level monitoring

Output level monitoring checks whether the output level remains within defined limits (the monitoring band) about an average value when it has settled. The settled state is defined by the control difference band $diFb$ about the process value. If the process value moves outside the monitoring band $toLy$, then an alarm signal is generated.

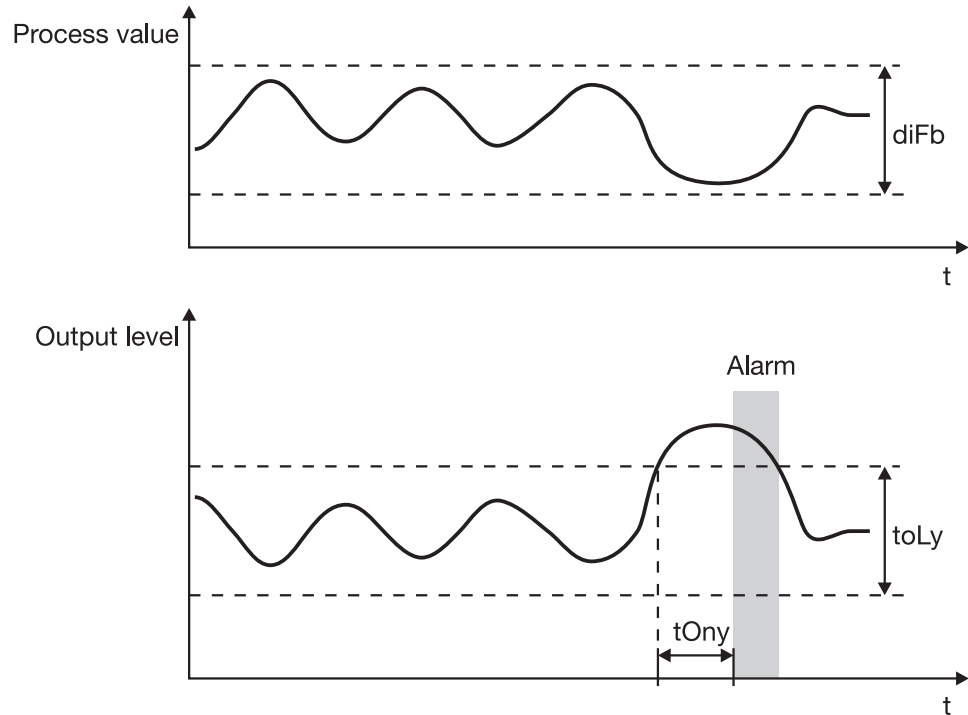

If a short excursion outside this band is tolerable, then the alarm can be suppressed for an adjustable time $tOny$.

Areas of application:

- monitoring for ageing effects and faults in the heater elements
- signaling of faults during operation.

The output level monitoring is inactive under the following conditions:

- during self-tuning
- in manual mode
- during ramp functions
- for program controllers
- for modulating controllers without output level feedback.

8 Configuration

The correct operation of the output level monitoring requires sensible dimensioning of the parameters that are used for the determination of the average output level.

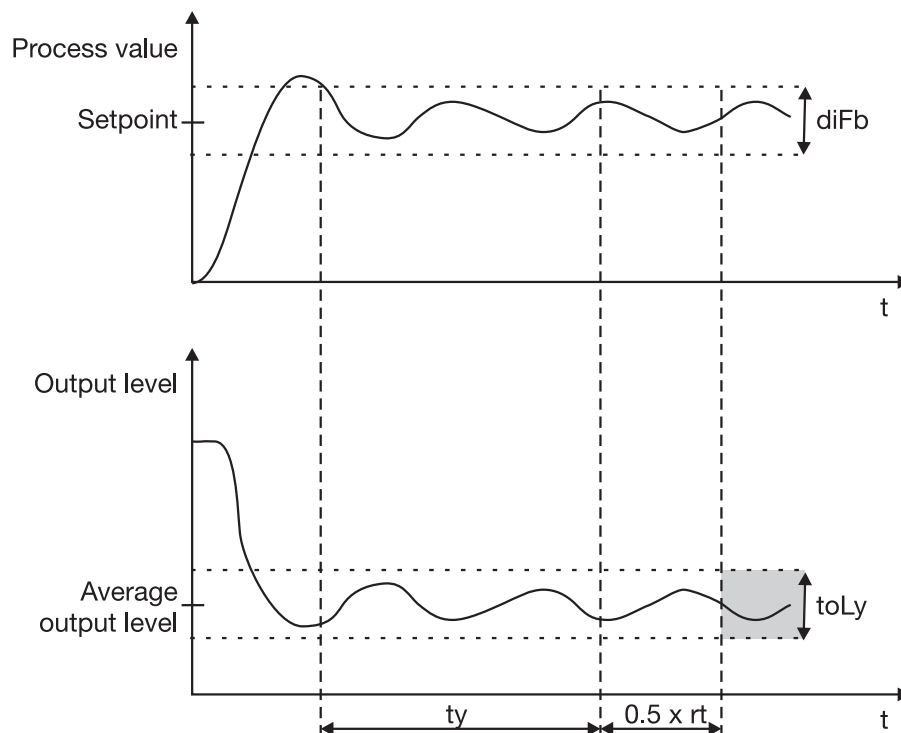

Control difference band diFb

The control difference band about the process value defines the settled state. It should be so dimensioned that there are no excursions outside the band in normal operation. The process value curve can be recorded (using the startup function of the setup program, for instance). The determination of the average output level starts when the process value enters the control difference band. The determination of the average output level starts again if the value goes outside the band in the meantime, or a setpoint change occurs that is larger than $0.5 \cdot \text{diFb}$.

Determination time ty

The adjustable determination time is used to calculate a moving average for the output level. The time should be set to be long enough to ensure an accurate calculation.

The determination time is followed by a waiting time of $0.5 \cdot \text{rt}$ (rt = reset time), while the system checks whether the process value and output level are within the predefined limits. If a limit is infringed, the calculation starts again.

The output level monitoring is then active, and monitors for excursions outside the monitoring band toLy .

If the alarm signal is to be given out by an output, then the corresponding output must be configured for "Output level monitoring".

⇒ Chapter 8.5 "Outputs "OutP""

Additional functions:

⇒ Chapter 8.6 "Binary functions "binF""

8 Configuration

Boost function

In order to move out tools during the production process, the zone temperature can be raised by an adjustable value through a binary function (factory setting: Binary input 1 (key)) for an adjustable time.

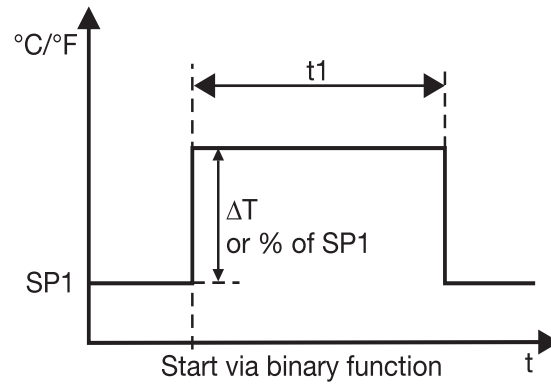

SP1 - setpoint 1 (in the user level "USER")

t1 - time for Timer 1 (see "Timer "tFct"" on Page 71)



boSt- activate boost function (in the user level "USER")

8.3 Generator “Pro”

Configuration
Analog inputs
Controller
Generator
Limit comparators
Outputs
Binary functions
Display
Timer
Interfaces

Pro: (Program) Generator

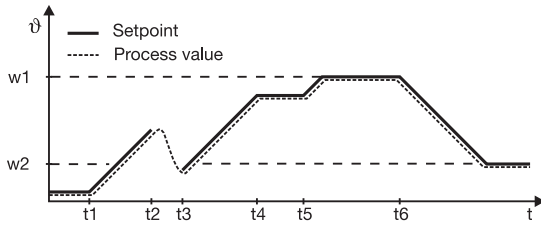
The basic function of the instrument is defined here. The instrument can be operated as a fixed-setpoint controller with or without a ramp function, or warm-up ramp for hot-channel equipment, program controller or program generator.

Symbol	Value/selection	Description
General		
Function	<i>Funct</i>	<p>0 Fixed-setpoint controller 1 Ramp function 2 Program controller 3 Program generator 4 Hot-channel controller</p> <p>Ramp function: A rising or a falling ramp function can be implemented. The ramp end value is determined by the setpoint input and can be altered from the ▲ and ▼ keys, just as for a fixed-setpoint controller.</p>  <p>t1 Power on (w1 aktiv) t2...t3 Power failure / manual operation / probe break t4...t5 Ramp stop t6 Setpoint changeover to w2</p> <p>The ramp function can be paused or canceled via the binary functions. ⇒ Chapter 8.6 “Binary functions “binF””</p> <p> The ramp function is interrupted on a probe break, or for manual mode. The outputs react as for overrange/underrange (configurable).</p> <p>Program generator: Is used, for instance, to output the setpoint profile via a continuous output without a control function. Settings for the program generator are not evaluated with regard to the process value (e. g. start at process value, continue, tolerance band).</p>

Factory settings are shown **bold**.

8 Configuration

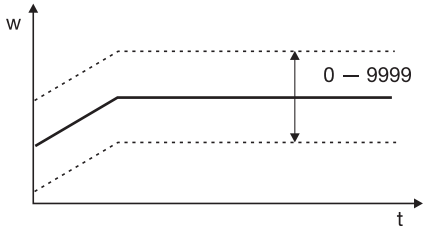
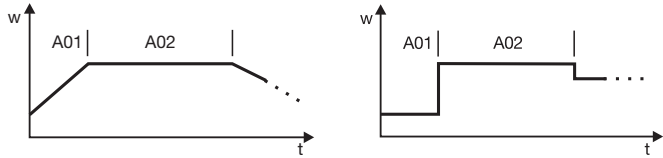
	Symbol	Value/selection	Description
Unit of slope	Unit	0 1 2	Ramp function Program °C/min mm:ss °C/hour hh:mm °C/day dd:hh s=seconds; m=minutes; h=hours;d=days Unit of ramp slope in °C per time unit, or format of segment times for program controller/generator.
Ramp slope	rASL	0...999.9	Value of slope for ramp function
Tolerance band	tolP	0...999	0=off For a program controller/generator and ramp function, the process value can be monitored by applying a tolerance band around the setpoint profile. If the upper or lower limit is infringed, a tolerance limit signal is generated, which is internally processed or produced via an output.  0 = switched off Processing the tolerance limit signal, see: ⇒ Chapter 8.5 "Outputs "OutP"" ⇒ Chapter 8.6 "Binary functions "binF""
Program			
Program start	(setup)	Program start start at the process value	Defines whether the program starts with the first program setpoint or whether the present process value is accepted as the first program setpoint.
Range response	(setup)	Continue pause program	Defines the response to over/underrange
Response to power-on	(setup)	No start automatic start	Defines whether the program starts on connecting the supply voltage.
Program repeat	(setup)	none cyclic	The "Cyclic" setting has the effect of continuously repeating the program.
Setpoint input	(setup)	Ramp Step	Setpoint ramp Setpoint step 
Control to the most recent setpoint	(setup)	inactive active	If active, the process is controlled to the most recent program setpoint after the program has ended.
Delay time	(setup)	0...9999 min	Delays the program start by an adjustable time. "Start" is shown in the lower display.
Basic status			
Control contacts	(setup)	SK1 SK2 SK3 SK4	The four control contacts can be activated in the basic status (when the program is not running).

Factory settings are shown **bold**.

Warm-up ramp for hot-channel equipment

The warm-up ramp for hot-channel equipment is used, for example, for the gentle operation of ceramic heater elements. Damage can be avoided by allowing moisture to evaporate slowly from the hygroscopic heater elements during the warm-up phase ($t_0 - t_2$).

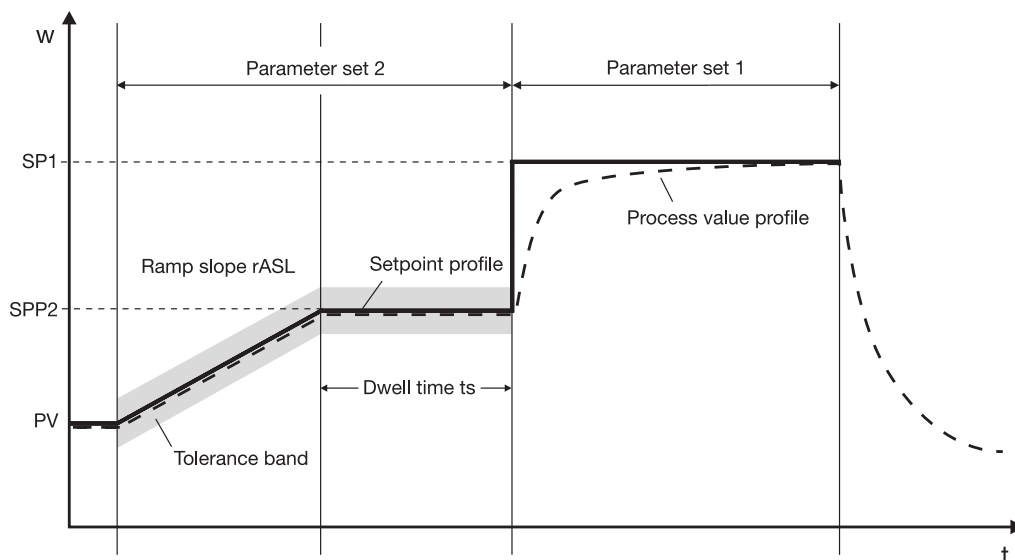

The present setpoint is accepted as the start value for the ramp at time t_0 . Within the time period $t_0 - t_1$, the programmed ramp slope $rASL$ is used to approach the hold setpoint SPA . Within this period, the ramp setpoint is increased linearly. This is followed by the programmable dwell time t_s ($t_1 - t_2$), after which the process is controlled to the present setpoint (factory setting: setpoint 1 = $SP1$).

The hot-channel function is implemented through the parameters in the user level.

⇒ Chapter 5.2 “Level concept”

- ramp slope $rASL$ with time unit
- dwell time t_s
- output level limit yA (optional, applies to parameter set 2)
- tolerance band (optional)

Setup/Generator/Program

- Configure program start to “Start at process value”
- Define response after power-on; the warm-up ramp either starts automatically when switching on the supply voltage, or by pressing the  key.

8 Configuration

8.4 Limit comparators “LC”

Configuration
Analog inputs
Controller
Generator
Limit comparators
Outputs
Binary functions
Display
Timer
Interfaces

LC: Limit comparator

Limit comparators (threshold monitors, limit contacts) can be used to monitor an input variable (process value for the limit comparator) against a fixed limit or another variable (the setpoint for the limit comparator). When a limit is exceeded, a signal can be output or an internal controller function initiated.

4 limit comparators are available.

Limit comparator functions (Ik)

Limit comparators can have different switching functions.

The hysteresis functions “asymmetrical, left” and “asymmetrical, right” can only be set through the setup program. The “symmetrical” hysteresis function is used as standard.

	Hysteresis function		
	asymmetrical, left	symmetrical	asymmetrical, right
Ik1			
Ik2			
Ik3			
Ik4			
Ik5			
Ik6			

8 Configuration

In the case of the limit comparator functions Ik7 and Ik8, the measurement that is set is monitored with respect to a fixed value AL.

		Hysteresis function		
	asymmetrical, left	symmetrical	asymmetrical, right	
Ik7				
Ik8				

Limit comparator 1 **LC1** →

Limit comparator 2 **LC2** →

Limit comparator 3 **LC3** →

Limit comparator 4 **LC4** →

Function	Symbol	Value/selection	Description
Function	Fnc1	0	no function
		1	Ik1
		2	Ik2
		3	Ik3
		4	Ik4
		5	Ik5
		6	Ik6
		7	Ik7
8	Ik8		
Limit value	AL	-1999... 0 ...+9999	Limit value to be monitored Limit range for Ik1 and Ik2: 0 — 9999
Switching differential	HYS1	0... 1 ...9999	Switching differential

Factory settings are shown **bold**.

8 Configuration

Limit comparator 1 LC1 →
 Limit comparator 2 LC2 →
 Limit comparator 3 LC3 →
 Limit comparator 4 LC4 →

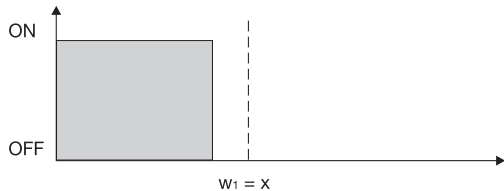
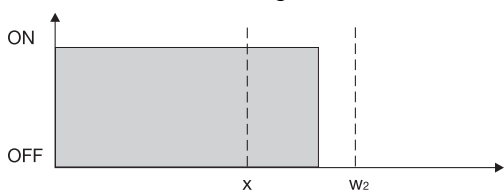
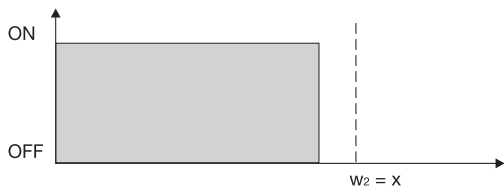
Symbol	Value/selection	Description			
Action/ range response	ACR	<p>0 absolute/off 1 relative/off 2 absolute/on 3 relative/on</p> <p>Action: Defines the switching action of the limit comparators on a setpoint change or power-on.</p> <p>absolute: At the time of alteration, the limit comparator acts according to its function.</p> <p>relative: The limit comparator is in the OFF status. An alteration of the limit value or the (limit comparator) setpoint could cause the limit comparator to switch ON. Such a reaction will be suppressed, and this condition is maintained until the (limit comparator) process value has moved out of the switch-on region (gray area). Example: Monitoring the (controller) process value x with function Ik4 Setpoint alteration $w_1 \rightarrow w_2$ a) Initial condition</p>  <p>b) Condition at the time of the alteration The limit comparator remains OFF, although the process value is within the switch-on region.</p>  <p>c) Stabilized condition The limit comparator again operates in accordance with its function.</p>  <p>This function also prevents a limit comparator from being triggered during the approach phase.</p>			
		Switch-on delay	t _{ON}	0...9999	Delays the switch-on edge by a definable time period
		Switch-off delay	t _{OFF}	0...9999s	Delays the switch-off edge by a definable time period

Factory settings are shown **bold**.

8 Configuration

Limit comparator 1 $LC1 \rightarrow$
 Limit comparator 2 $LC2 \rightarrow$
 Limit comparator 3 $LC3 \rightarrow$
 Limit comparator 4 $LC4 \rightarrow$

	Symbol	Value/selection	Description
Acknowledgement	$ACKL$	0 1 2	no acknowledgement 1 acknowledgement; only with inactive limit comparator 2 acknowledgement; always possible For settings with acknowledgement, the limit comparator is latching, which means it remains ON, even when the switch-on condition is no longer present. The limit comparator must be reset via the \blacktriangledown + EXIT keys or binary signal.
Pulse time	$tPUL$	0...9999s	The limit comparator is automatically reset after an adjustable time period.
Limit comparator PV	$LCPr$	(analog selector) process value	see circuit diagrams
Limit comparator SP	$LCSP$	(analog selector) present setpoint	see circuit diagrams (only with Ik1 – Ik6)
Hysteresis function	(setup)	symmetrical asymmetrical, left asymmetrical, right	see circuit diagrams ⇒ Chapter 12.2 “Alarm messages”

Factory settings are shown **bold**.

Analog selector

0	no function	21	program run time in sec
1	analog input 1	22	residual program time in sec
2	analog input 2	23	segment run time in sec
3	process value	24	residual segment time in sec
4	present setpoint	25	timer run time for timer 1 in sec
5	ramp end value	26	timer run time for timer 2 in sec
6	program setpoint	27	residual run time for timer 1 in sec
7	math 1	28	residual run time for timer 2 in sec
8	math 2	29	present segment end value
9	setpoint 1	30	analog marker (Profibus)
10	setpoint 2	31	reserved
13	controller output level	32	reserved
14	controller output 1	33	reserved
15	controller output 2		

8 Configuration

8.5 Outputs “OutP”

Configuration
Analog inputs
Controller
Generator
Limit comparators
Outputs
Binary functions
Display
Timer
Interfaces

OutP: Outputs

Configuration of the instrument outputs are subdivided into analog outputs (OutA; max. 2) and binary outputs (OutL; max. 9). Binary outputs are relay, solid-state relay and logic outputs. Display and numbering of the outputs depends on the assignment of the option slots.

The switching states of the binary outputs 1 – 6 are shown in the display.

Numbering of the outputs

Standard for all instrument versions:

(Binary) output 1 (Out1) = relay

(Binary) output 2 (Out2) = relay

(Binary) output 3 (Out3) = logic output

(Binary) output 4 (Out4) = logic output

Extended numbering for the option slots:

Slot	Plug-in board with 1 analog output	Plug-in board with 1 binary output (relay or solid-state relay)	Plug-in board with 2 binary outputs (2 relays)
Option 1	Output 5 (Out5)	Output 5 (Out5)	Output 5+8 (Out5/Out8)
Option 2	Output 6 (Out6)	Output 6 (Out6)	Output 6+9 (Out6/Out9)
Option 3	Output 7 (Out7)	Output 7 (Out7)	Output 7+10 (Out7/Out0)

8 Configuration



Binary outputs $\text{Out}L$

	Symbol	Value/selection	Description
Binary output 1	$\text{Out}1$	0	no function
		1	Controller output 1 (ex-factory with Out1)
		2	Controller output 2
...	...	5	Binary input 1
		6	Binary input 2
Binary output 10	$\text{Out}0$	7	Binary input 3
		8	Binary input 4
		9	Binary input 5
		10	Binary input 6
		11	Binary input 7
		12	Binary input 8
		13	Limit comparator 1
		14	Limit comparator 2
		15	Limit comparator 3
		16	Limit comparator 4
		17	Control contact 1
		18	Control contact 2
		19	Control contact 3
		20	Control contact 4
		21	Logic formula 1
		22	Logic formula 2
		23	Timer 1 active
		24	Timer 2 active
		25	Program active
		26	Program end signal
		27	Tolerance limit signal
		28	Manual mode on/off
		29	Control loop monitoring
		30	Output level monitoring
		31	Binary marker
		32	Any binary value from storage address (only through setup)
		33	always active

Factory settings are shown **bold**.

8 Configuration

Analog outputs $OutA \rightarrow$ Output 5 $Out5 \rightarrow$
 Output 6 $Out6 \rightarrow$
 Output 7 $Out7 \rightarrow$

	Symbol	Value/selection	Description									
Function	$Funct$	(analog selector) switched off	Function of the output									
Type of signal	S, Sn		Physical output signal 0 0 – 10V 1 2 – 10V 2 0 – 20mA 3 4 – 20mA									
Range output	$rOut$	0...101%	Signal on going above/below range 101 = last output signal  If the output is a controller output, the controller switches over to manual mode and produces the output level defined in chapter "Controller Cntr" under rOut. Chapter 8.2 "Controller "Cntr""									
Zero point	$OPnt$	-1999... 0 ...+9999	A physical output signal is assigned to the value range of an output variable.									
End value	End	-1999... 100 ...+9999	Ex-factory, the setting corresponds to an output level of 0 – 100% for controller outputs. No changes of the ex-factory setting are required for continous controllers with only one output.  Setting for controller outputs for cooling With 3-state controllers, the following settings must be predefined: zero: 0 / end value: -100 Example (function as a transducer): An analog output (0 – 20mA) is to be used to put out the process value (value range 150 to 500 °C), that means: 150 to 500°C = 0 – 20mA; Zero point: 150 / End value: 500									
Offset	(setup)	-1999... 0 ...+9999	The offset is used to correct the output signal by a certain amount upwards or downwards. Examples: <table border="1" style="margin-left: 20px;"> <thead> <tr> <th>Original value</th> <th>Offset</th> <th>Output value</th> </tr> </thead> <tbody> <tr> <td>294.7</td> <td>+0.3</td> <td>295.0</td> </tr> <tr> <td>295.3</td> <td>- 0.3</td> <td>295.0</td> </tr> </tbody> </table>	Original value	Offset	Output value	294.7	+0.3	295.0	295.3	- 0.3	295.0
Original value	Offset	Output value										
294.7	+0.3	295.0										
295.3	- 0.3	295.0										

Factory settings are shown **bold**.

Analog selector

0 no function	21 program run time in sec
1 analog input 1	22 residual program time in sec
2 analog input 2	23 segment run time in sec
3 process value	24 residual segment time in sec
4 present setpoint	25 timer run time for timer 1 in sec
5 ramp end value	26 timer run time for timer 2 in sec
6 program setpoint	27 residual run time for timer 1 in sec
7 math 1	28 residual run time for timer 2 in sec
8 math 2	29 present segment end value
9 setpoint 1	30 analog marker (Profibus)
10 setpoint 2	31 reserved
13 controller output level	32 reserved
14 controller output 1	33 reserved
15 controller output 2	

8.6 Binary functions “binF”

Configuration

Analog inputs
Controller
Generator
Limit comparators
Outputs
Binary functions
Display
Timer
Interfaces

binF: Binary functions

Functions are assigned here to the binary signals of the binary inputs and limit comparators.

In addition, the functions for control contacts, tolerance limit signal and program end signal are defined for program controllers/generators.

In the case of a fixed-setpoint controller, functions can be assigned to the ramp end signals.

Switching action

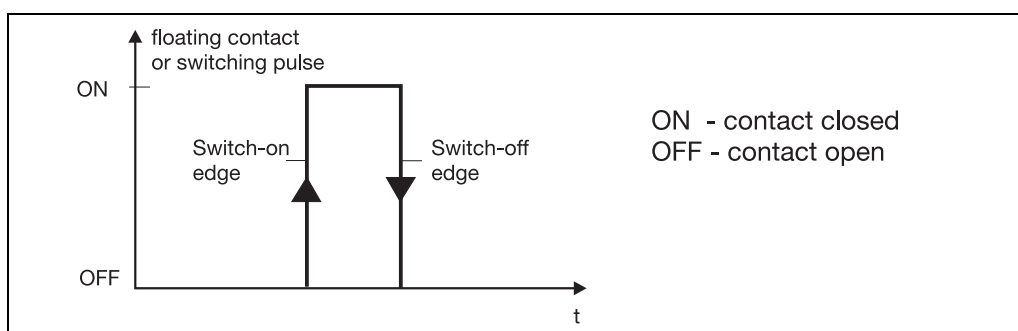

The functions are arranged in two groups:

Edge-triggered functions

The binary function reacts to switch-on edges.

The following functions are edge-triggered:

- Start/stop of self-tuning
- Acknowledge limit comparators
- Program start/cancel
- Start timer
- Segment change

State-triggered functions

The binary function reacts to switch-on or switch-off states.

- All remaining functions

8 Configuration

	Symbol	Value/selection	Description
Binary input 1	<i>bin1</i>		0 no function
...			1 Start self-tuning
Binary input 8	<i>bin8</i>		2 Cancel self-tuning
Limit comparator 1	<i>LC1</i>		3 Change to manual mode
...			4 Controller off (controller outputs are switched off)
Limit comparator 4	<i>LC4</i>		5 Inhibit manual mode
Timer 1	<i>TF1</i>		6 Hold ramp
Timer 2	<i>TF2</i>		7 Cancel ramp
Logic 1	<i>Lo1</i>		8 Setpoint changeover
Logic 2	<i>Lo2</i>		9 Parameter set switching
Control contact 1	<i>CC1</i>		10 Key inhibit
...			11 Level inhibit
Control contact 4	<i>CC4</i>		12 Display "off" with key inhibit
Tolerance limit signal	<i>toLS</i>		13 Acknowledge limit comparators
Program end signal	<i>PRE5</i>		14 Inhibit program start
Control loop monitoring signal	<i>CLoS</i>		15 Start program
Output level monitoring signal	<i>OLES</i>		16 Pause program
			17 Cancel program
			18 Segment change
			19 Start timer 1 (boost function)
			20 Start timer 2
			21 Cancel timer 1
			22 Cancel timer 2
			Level inhibit: The parameter and configuration levels are inhibited.
			Program end signal: The signal is active after approx. 1 second (pulse)
			Text display: If the binary function is active, a configurable text is shown in the lower display. The text can be uniquely defined (only through the setup program).
			Factory setting: Binary input 1 = 19 (start boost function) Binary input 2 = 8 (setpoint switching (reduction)) otherwise = 0 (no function)

Factory settings are shown **bold**.

Setpoint and parameter set switching

A binary function can be used to switch between setpoint 1 and setpoint 2 or parameter set 1 and parameter set 2.

Setpoint switching	Parameter set switching	Binary signal
Setpoint 1 active	Parameter set 1 active	0/contact open
Setpoint 2 active	Parameter set 2 active	1/contact closed

8 Configuration

In order to switch between the four possible setpoints, two binary functions must be configured to “setpoint switching”. The states of the two binary functions are designated Z1 and Z2 and switch the setpoints over as shown in the table below:

Setpoint	Z2	Z1
Setpoint 1	0	0
Setpoint 2	0	1
Setpoint 3	1	0
Setpoint 4	1	1

0 = contact open /OFF

1 = contact closed /ON

The states Z1 and Z2 are assigned to the binary functions in descending order (see list on the right), i.e. the first binary function selected in the list is Z1.

Control variable	State
Binary input 1	
...	
Binary input 8	
Limit comparator 1	
...	
Limit comparator 4	
Timer 1	→ Z1
Timer 2	→ Z2
Logic formula 1	
Logic formula 2	
Control contact 1*	
...	
Control contact 4*	
Tolerance limit signal*	
Program end signal*	

* only for program controller/generator

Example:

The setpoint is to be selected via a binary input and the state of one limit comparator.

This results in the following assignment:

Z1 - binary input 1

Z2 - limit comparator 1

The binary function for binary input 1 and limit comparator 1 must be configured to “setpoint switching”

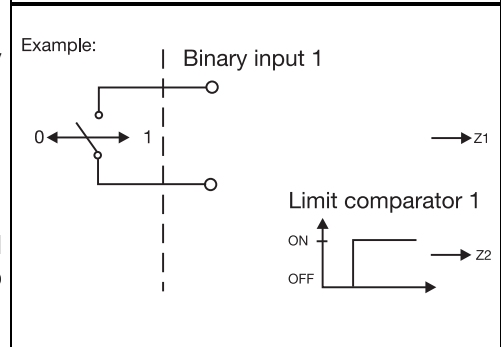

8 Configuration

Depending on the further configuration, the following diagram applies:

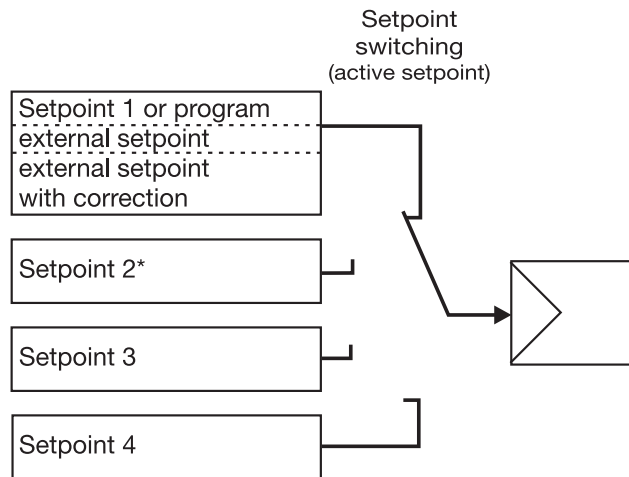

* An exception to this is the configuration for a program controller with external setpoint input, with or without correction. Setpoint 2 is the program setpoint in this case.

Reduction function

For cleaning tools, and for changing colors during the production process, the zone temperature can be reduced through the binary function “Setpoint switching” to a quiescent setpoint. As a factory setting, this is performed via Binary input 2, but can also be activated by a different signal.

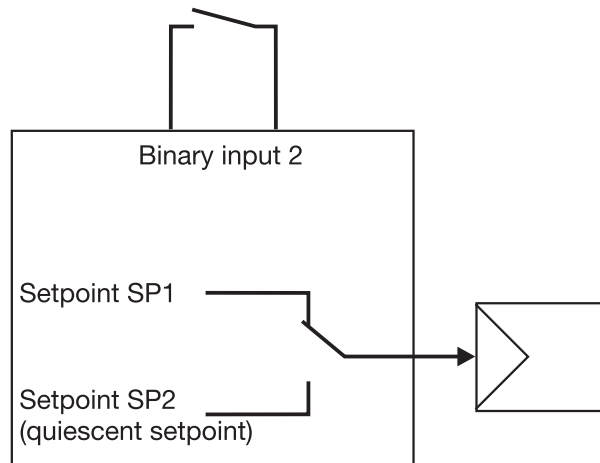

The required setpoints are set in the operator level (OPr).

⇒ Chapter 6 “Operator level”

Binary input 2 must be wired up accordingly (switch).

Additional functions via the setup program

Several binary functions can be combined through the setup program. In addition, the binary function “Text display” can be implemented. This is used to show a letter combination in the lower display.

8.7 Display “diSP”

Configuration
Analog inputs
Controller
Generator
Limit comparators
Outputs
Binary functions
Display
Timer
Interfaces

diSP: Display

The values displayed can be matched to the existing requirements. Furthermore, time-out and level inhibit can be configured here.

	Symbol	Value/selection	Description
General			
Upper display	d, SU	(analog selector) process value	Displayed value for the upper display
Lower display	d, SL	(analog selector) present setpoint	Displayed value for the lower display
16-segment display (display 3)	d, SE		Displayed value for the two-digit 16-segment display 0 Switched off 1 Unit (°C or °F) 2 Current segment 3 Current parameter set 4 Text (only through setup program!)
Time-out	TOU	0...180...255s	Time period, after which the instrument automatically returns to normal display if no key is pressed.
Decimal point	dEP		0 no decimal place 1 one decimal place 2 two decimal places If the value that is to be displayed can no longer be represented with the programmed decimal point, then the number of decimal places will be automatically reduced. If, subsequently, the measured value decreases, the number increases to the programmed value of the decimal point.
Brightness	br, B	0...5	(bright) 0 – 5 (dark)
Level inhibit	(setup)	none configuration level parameter/ configuration level operator/ parameter/ configuration level	The access to the individual levels can be inhibited. The setting is independent of the binary function “level inhibit”. Inhibiting the parameter level will, at the same time, also inhibit the start of self-tuning.
User data (setup program)			
Up to eight parameters from different levels can be shown under User data (operator level) on the instrument and edited. The symbols for these parameters (shown in the lower display) must be assigned by the user himself.			

Factory settings are shown **bold**.

8 Configuration

Analog selector	0	no function	21	program run time in sec
	1	analog input 1	22	residual program time in sec
	2	analog input 2	23	segment run time in sec
	3	process value	24	residual segment time in sec
	4	present setpoint	25	timer run time for timer 1 in sec
	5	ramp end value	26	timer run time for timer 2 in sec
	6	program setpoint	27	residual run time for timer 1 in sec
	7	math 1	28	residual run time for timer 2 in sec
	8	math 2	29	present segment end value
	9	setpoint 1	30	analog marker (Profibus)
	10	setpoint 2	31	reserved
	11	setpoint 3	32	reserved
	12	setpoint 4	33	reserved
	13	controller output level		
	14	controller output 1		
15	controller output 2			

8.8 Timer “tFct”

Configuration
Analog inputs
Controller
Generator
Limit comparators
Outputs
Binary functions
Display
Timer
Interfaces

tFct: Timer function

Time-dependent control actions can be carried out with the help of the timer. The timer signal (timer 1 + 2) shows whether the timer is active. It can be output via the binary outputs or processed internally.

The timers are started or canceled via the binary functions.

⇒ Chapter 8.6 “Binary functions “binF””

The current timer run times can be viewed at the operator level (process data).



Timer 1 is reserved for the boost function.

Timer 1 tF1 →

Timer 2 tF2 →

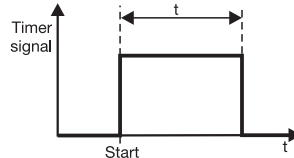
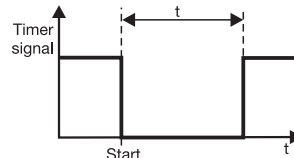
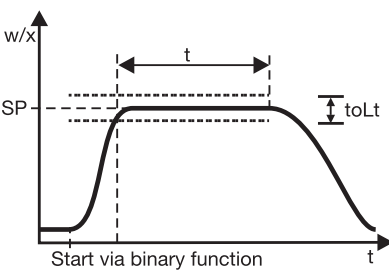
Function	Symbol	Value/selection	Description
	Funct		<p>0 no function</p> <p>1 with timer running: timer signal=1 (signal is active) / unit of time: hh:mm</p> <p>2 with timer running: timer signal=0 (signal is inactive) / unit of time: hh:mm</p> <p>3 tolerance band / unit of time: hh:mm</p> <p>4 with timer running: timer signal=1 (signal is active) / unit of time: mm:ss</p> <p>5 with timer running: timer signal=0 (signal is inactive) / unit of time: mm:ss</p> <p>6 tolerance band / unit of time: mm:ss</p> <p>Signal active  Signal inactive </p> <p>Function: “Tolerance band” </p> <p>Time is running when the process value has reached a tolerance band around the setpoint. Timer signal=1 (signal is active) while time is running.</p> <p>Factory setting: Timer 1 = 1 (boost function) Timer 2 = 0 (no function)</p>
Timer setting	t	0...99:59	Time input (unit of time, see “Function”)
Tolerance limit	tol	0...999	0=off

Factory settings are shown **bold**.

8 Configuration

8.9 Interfaces “IntF”

Configuration
Analog inputs
Controller
Generator
Limit comparators
Outputs
Binary functions
Display
Timer
Interfaces

IntF: Interfaces

The interface parameters must be configured for the RS422/485 or current interface, or the Profibus-DP interface, in order to communicate with PCs, bus systems and peripheral devices.

PROFIBUS-DP PROF →

	Symbol	Value/selection	Description
Protocol	<i>Prot</i>	0 1 2	Intel Motorola Intel integer
Device address	<i>Adr</i>	0... 125 ...255	Address in data network
Analog marker	<i>AnAP</i>	-1999... 0 ...+9999	Analog value
Binary marker	<i>binP</i>	0 ...255	Binary value

Factory settings are shown **bold**.

Modbus / current interface r422 →

	Symbol	Value/selection	Description
Protocol	<i>Prot</i>	0 1 2 3	Modbus Modbus integer Modbus master Arburg
Baud rate	<i>bdrb</i>	0 1 2 3	9600 Baud 19200 Baud 38400 Baud 4800 Baud
Data format	<i>dft</i>	0 1 2 3	8 data bits, 1 stop bit, no parity 8 data bits, 1 stop bit, odd parity 8 data bits, 1 stop bit, even parity 8 data bits, 2 stop bits, no parity
Device address	<i>Adr</i>	0... 1 ...255	Address in data network
Min. response time	(setup)	0 ...500ms	Minimum time that elapses between the request of a device in the data network and the response of the controller.

Factory settings are shown **bold**.



- Interface descriptions:
- B70.3041.2.0 (Modbus)
 - B70.3041.2.3 (PROFIBUS-DP)

8 Configuration

Modbus master

The instrument can be used as an autonomous master in a Modbus system. It is then possible to send data to all other devices (slaves) in the Modbus system by pressing a key or using a binary function. The slaves must all be devices of the same type.

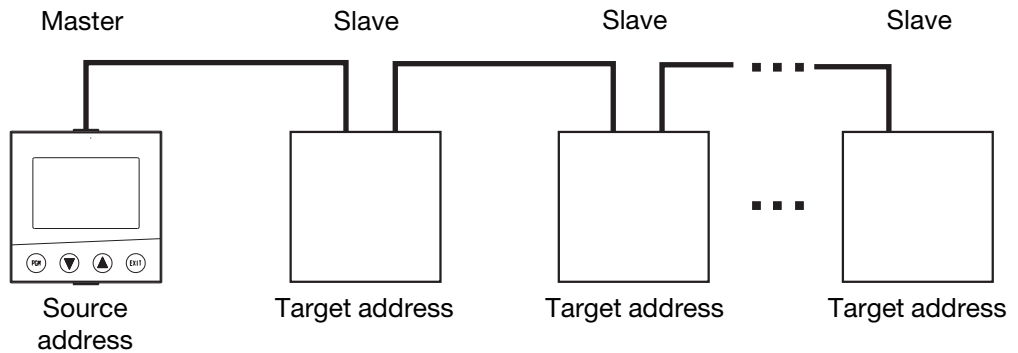

- * The source address for the required parameter can be found in the B70.3041.2.0 interface description.
- * If the target address does not correspond to the same parameter as the source address, then click on the check box.
(The number of parameters to be sent will thereby be reduced by 1.)
The target address can be taken from the documentation for the slave device.
- * Enter the word length for the parameter
(see interface description; INT=1, LONG=2, FLOAT=2)

Transmission of the parameters to the slaves is started by a (configurable) binary signal, or the key combination + **EXIT**. For a binary signal the parameters are repeatedly transmitted (cyclically) as long as the signal is active.

Example:

The (filtered) process value from the master is to be used as a setpoint for all slaves. The transmission is initiated by pressing a key.

Modbus-Quelladresse im Mastergerät	Modbus-Zieladresse im Slavegerät	Wortanzahl
0x0045	<input checked="" type="checkbox"/> 0x0045	2
0x0000	<input type="checkbox"/> 0x0000	0
0x0000	<input type="checkbox"/> 0x0000	0
0x0000	<input type="checkbox"/> 0x0000	0
0x0000	<input type="checkbox"/> 0x0000	0
0x0000	<input type="checkbox"/> 0x0000	0
0x0000	<input type="checkbox"/> 0x0000	0
0x0000	<input type="checkbox"/> 0x0000	0
0x0000	<input type="checkbox"/> 0x0000	0

Signal:

OK Abbrechen

8 Configuration

9 Tuning (optimization)

9.1 Self-tuning (self-optimization)

Oscillation method

Self-tuning (self-optimization, SO) establishes the optimum controller parameters for a PID or PI controller.

Depending on the controller type, the following controller parameters can be defined: Reset time (t_r), derivative time (t_d), proportional band (P_b), cycle time (C_y), filter time constant (dF)

The controller selects one of two procedures (**a** or **b**), depending on the size of the control deviation:

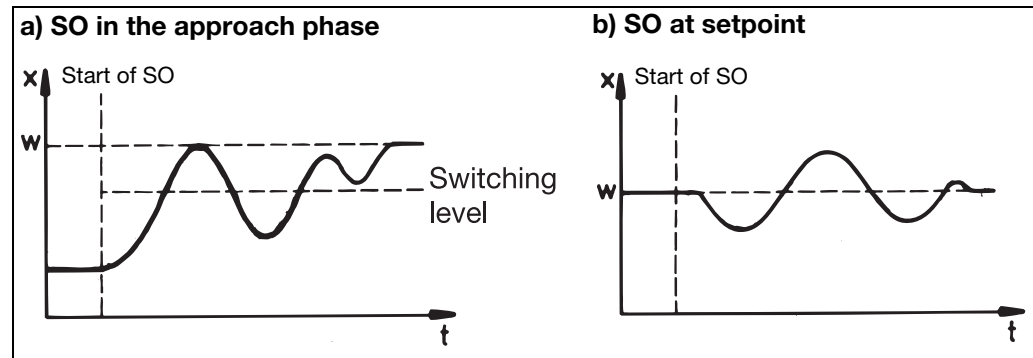

Step response method

This type of optimization involves determining the control parameters through an output step that is applied to the process. First a standby output is produced until the process value is "steady" (constant). Afterwards, an output step (step size), which can be defined by the user, is automatically applied to the process. The resulting response of the process value is used to calculate the control parameters.

Self-tuning establishes the optimum control parameters for a PID or PI controller, according to the selected control structure.

Depending on the controller type, the following control parameters can be determined: Reset time (t_r), derivative time (t_d), proportional band (P_b), cycle time (C_y), filter time constant (dF)

Self-tuning can be started from any system status, and can be repeated as often as is required.

The controller outputs (continuous, relay, solid-state), the controller standby output and the step size (min. 10%) have to be defined.

Principal applications of the step response method

- Self-tuning instantly after "power on", during the approach phase
Considerable time savings, setting: controller standby output = 0 %.
- The process does not readily permit oscillations (e.g. highly insulated furnaces with small losses, long oscillation period)
- Process value must not exceed setpoint
If the output (with stabilized setpoint) is known, overshoot can be avoided through the following adjustment:
standby output + step size \leq output in stabilized condition

9 Tuning (optimization)



With output type “solid-state”, the cycle time during self-tuning is reduced to 8 x the sampling cycle time.

With the “relay” output type, care has to be taken that the process value is not influenced by the cycle time, since otherwise tuning can not be completed successfully.

Solution: Reduce the cycle time C_y , until the process value is no longer influenced. (Manual mode can be used for the adjustment!)

Start of self-tuning after power-on and during the approach phase

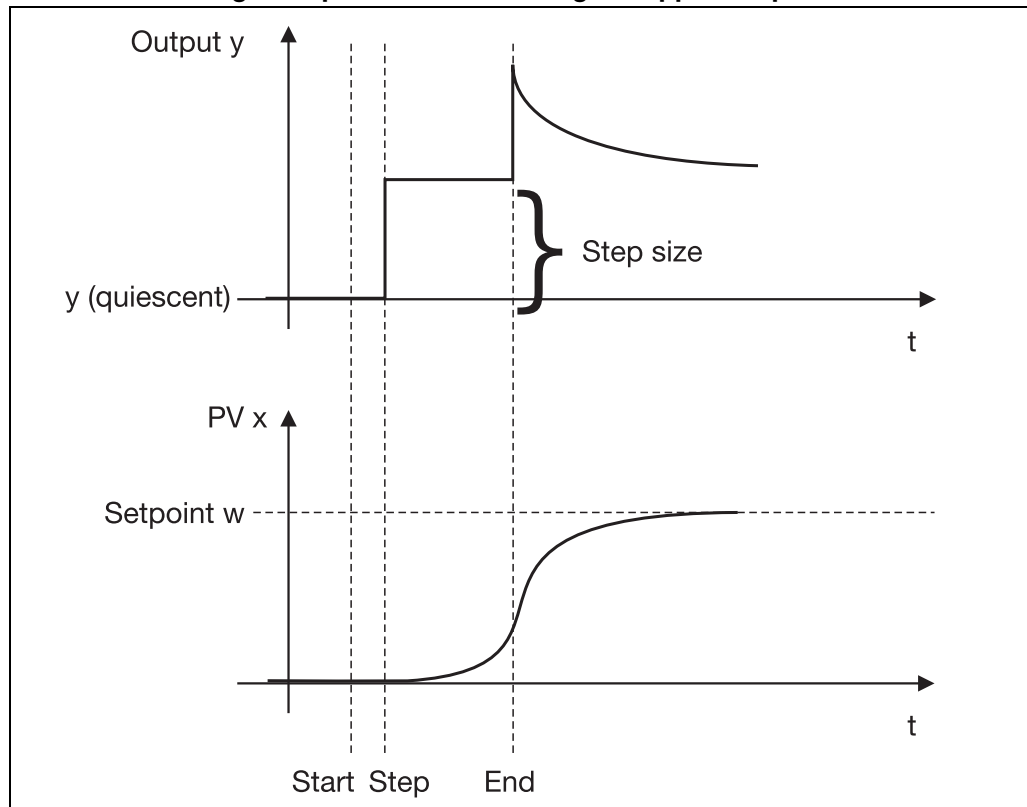

9 Tuning (optimization)

Start of self-tuning during operation

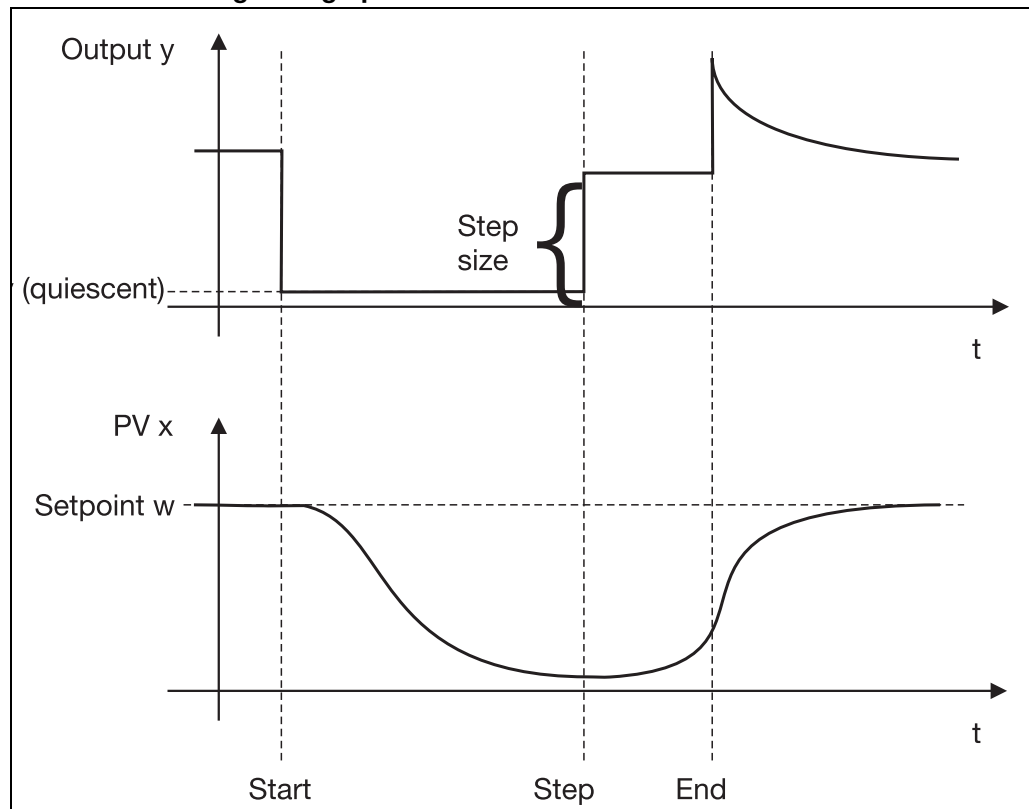

Starting self-tuning

- * Start with ▲ and ▼ (simultaneously >4sec
"tUnE" is shown, blinking, in the lower display

Tuning is ended when the display automatically changes over to normal display.

The duration of tuning depends on the control process.



The type of controller outputs has to be defined for autotuning.

⇒ Chapter 8.2 "Controller "Cntr""

For a device configured as program controller, the autotuning can only be started if no program is running (normal display).

In case of problems, you may find further information at www.jumo.net (Support/FAQ).

Canceling self-tuning

- * Cancel with ▲ and ▼ (simultaneously)

9 Tuning (optimization)

9.2 Checking the tuning

The optimum adaptation of the controller to the process can be checked by recording the approach phase (e.g. with Startup) with the control loop closed. The diagrams below indicate possible maladjustments and how these can be corrected.

The control response of a third-order control loop for a PID controller is shown as an example. However, the procedure for adjusting the controller parameters can also be applied to other control loops.

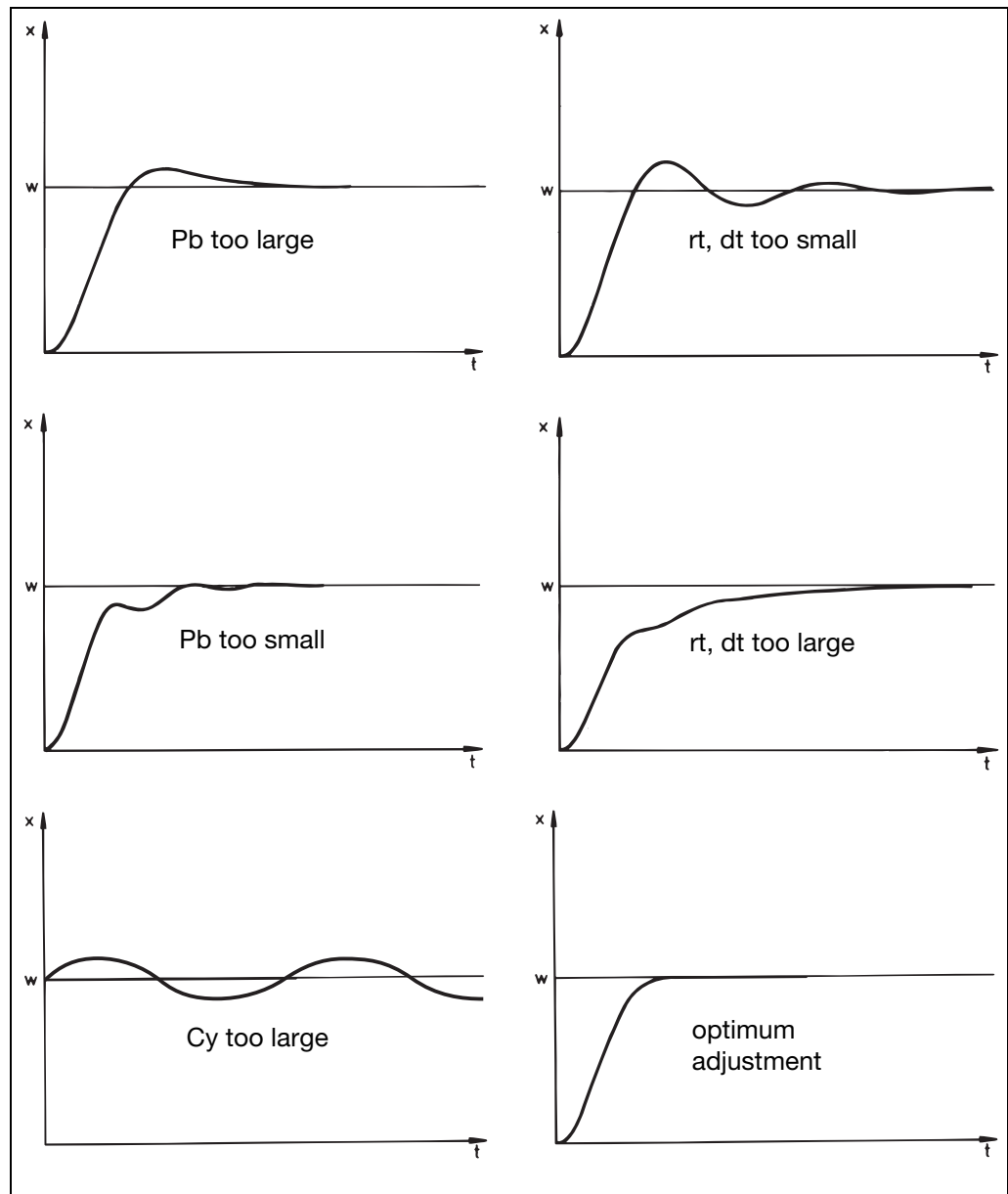

10.1 Math and logic module

The setup program can be used to implement two mathematical calculations or logical combinations of various signals and process variables from the controller in a formula.

With math formulae, the calculated result is presented through the two signals “Math 1” and “Math 2” of the analog selector. With logic formulae, the result of the logical combination is available through the signals “Logic 1” and “Logic 2” of the binary selector and when configuring the binary functions.

Chapter 8.6 “Binary functions “binF””

Entering formulae

- The string of signs in the formula consists of ASCII characters, and can have a maximum length of 60 characters.
- The formula can only be entered in the setup program.
- Formulae can be freely entered according to normal mathematical rules.
- Spaces can be inserted at will into the formula character string. But spaces are not permitted within function labels, variable names and constants.

10.2 Difference, humidity or ratio controller

The controller is preset either as a difference/humidity or ratio controller (extra code) or must be configured via the setup program. Analog input 2 must be available.

⇒ *Setup/Only setup/Math/Logic/Math 1*

The process variables for the two analog inputs have a fixed definition.

Difference control

The difference between the measurements from analog input 1 and 2 is formed and made available via “Math 1”. Input 1 is affected by the controller. Input 2 is the reference value.

Difference: $E1 - E2$

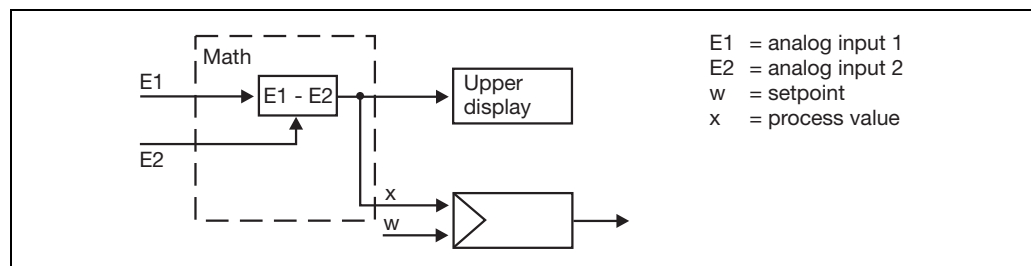

For the controller to function as a difference controller, further settings have to be made:

- controller process value: math 1
- ⇒ Chapter 8.2 “Controller “Cntr””

If the difference is to be displayed, then one display must be configured to “Math 1”.

⇒ Chapter 8.7 “Display “diSP””

10 Extra codes

Humidity control

A psychrometric humidity sensor is used to determine relative humidity, through the mathematical combination of wet bulb and dry bulb temperatures.

relative humidity: (E1, E2)

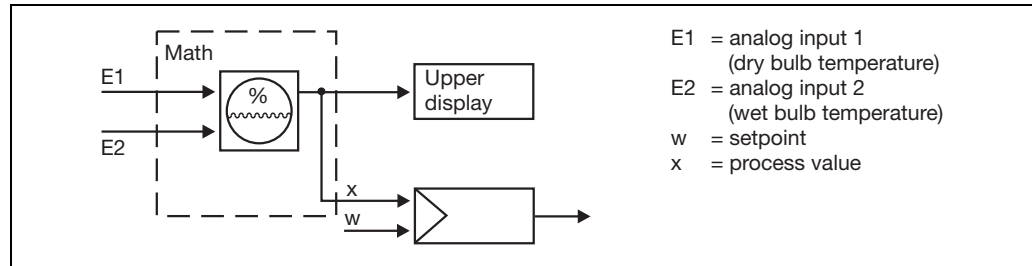

For the controller to function as a humidity controller, further settings have to be made:

- controller process value: math 1
- ⇒ Chapter 8.2 “Controller “Cntr””

If the value for relative humidity needs to be displayed, then one display must be configured to “Math 1”.

⇒ Chapter 8.7 “Display “diSP””

Ratio control

The control is always based on analog input 1 (E1).

The math module forms the ratio of the measurements from E1 and E2, and produces the setpoint for the controller. The ratio of the measurements can be called up through the function “Math 1” and displayed.

The required ratio E1/E2 is programmed as the setpoint (ratio setpoint) in the setpoint definition.

Ratio: E1/E2

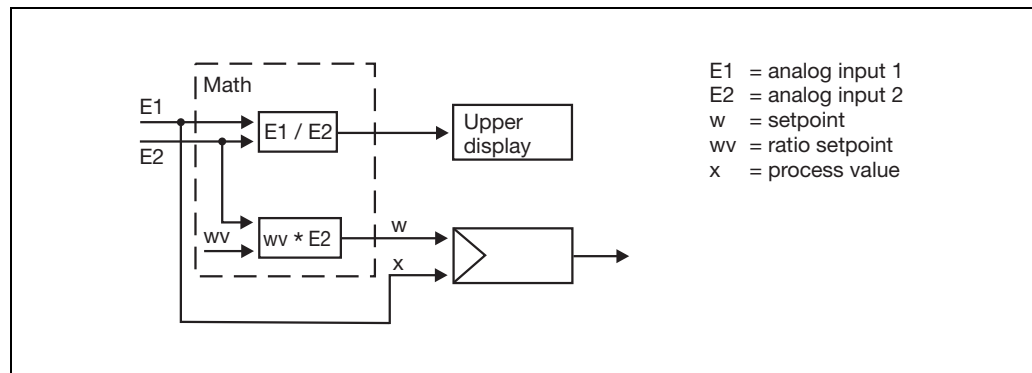

For the controller to function as a ratio controller, further settings have to be made:

- controller process value: analog input 1
 - external setpoint: ramp end value
- ⇒ Chapter 8.2 “Controller “Cntr””

If the ratio needs to be displayed, then one display must be configured to “Math 1”.

⇒ Chapter 8.7 “Display “diSP””

11 Retrofitting of modules

Safety notes



Retrofitting must only be carried out by qualified professional persons.



The modules can be damaged by electrostatic discharge. So avoid electrostatic charge during fitting and removal. Carry out retrofitting on a workbench that is earthed.

Identifying the module

* Identify the module by the part no. (TN) glued onto the packaging

Module	Code	Part no. (TN)	View of boards
Analog input 2	1	00776490	
1 relay (changeover, SPDT)	2	00442786	
2 relays (make, SPST-NO)	3	00442787	
1 analog output	4	00442788	
2 binary inputs	5	00442789	
1 solid-state relay 230V/1A	6	00442790	
RS422/485 interface	7	00442782	
PROFIBUS-DP	8	00442791	
20 mA current interface	9	00463952	-

11 Retrofitting of modules

Removing the controller module

- * Press together the knurled surfaces on the front panel and pull out the controller module.

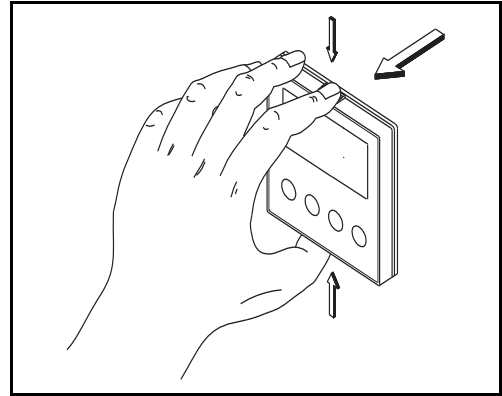

Retrofitting of modules

- * Select the slot for the option (Observe the restrictions for Type 703045! (see connection diagram))

Type 703045

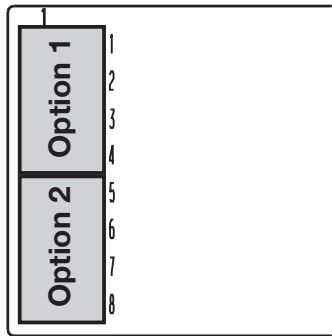

-  On Type 703045, relays can only be retrofitted in option slot 1!

Type 703046/48

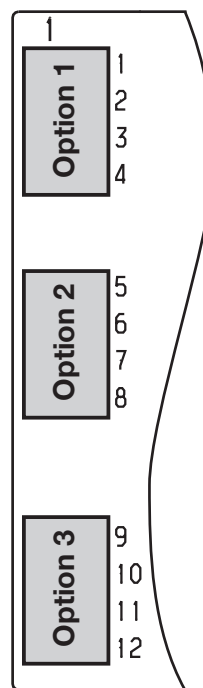

- * Push the module into the slot until the plug connector snaps into place

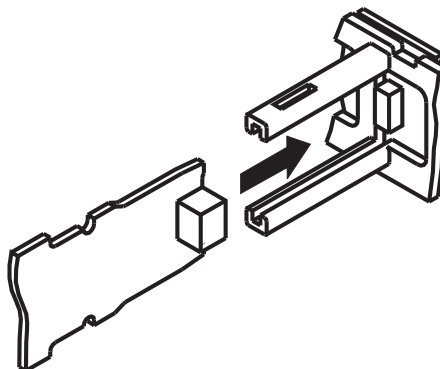

- * Push the module into the housing until the lugs snap into their slots

12.1 Technical data

Thermocouple input

Designation	Measuring range	Measuring accuracy	Ambient temperature error
Fe-Con L	-200 to + 900 °C	≤0.25%	100 ppm / °C
Fe-Con J EN 60 584	-200 to +1200 °C	≤0.25%	100 ppm / °C
Cu-Con U	-200 to + 600 °C	≤0.25%	100 ppm / °C
Cu-Con T EN 60 584	-200 to + 400 °C	≤0.25%	100 ppm / °C
NiCr-Ni K EN 60 584	-200 to +1372 °C	≤0.25%	100 ppm / °C
NiCr-Con E EN 60 584	-200 to +1000 °C	≤0.25%	100 ppm / °C
NiCrSi-NiSi N EN 60 584	-100 to +1300 °C	≤0.25%	100 ppm / °C
Pt10Rh-Pt S EN 60 584	0 to 1768 °C	≤0.25%	100 ppm / °C
Pt13Rh-Pt R EN 60 584	0 to 1768 °C	≤0.25%	100 ppm / °C
Pt30Rh-Pt6Rh B EN 60 584	0 to 1820 °C	≤0.25% ¹	100 ppm / °C
W5Re-W26Re C	0 to 2320 °C	≤0.25%	100 ppm / °C
W3Re-W25Re D	0 to 2495 °C	≤0.25%	100 ppm / °C
W3Re-W26Re	0 to 2400 °C	≤0.25%	100 ppm / °C
Cold junction	Pt100, internal		

1. in the range 300 to 1820 °C

Input for resistance thermometer

Designation	Connection	Measuring range	Measuring accuracy		Ambient temperature error
			3-/4-wire	2-wire	
Pt100 EN 60 751 (factory setting)	2-wire / 3-wire / 4-wire	-200 to +850 °C	≤0.05%	≤0.4%	50 ppm / °C
Pt500 EN 60 751	2-wire / 3-wire / 4-wire	-200 to +850 °C	≤0.2%	≤0.4%	100 ppm / °C
Pt1000 EN 60 751	2-wire / 3-wire / 4-wire	-200 to +850 °C	≤0.1%	≤0.2%	50 ppm / °C
KTY11-6	2-wire	-50 to +150 °C	—	≤2.0%	50 ppm / °C
Sensor lead resistance	max. 30Ω per lead for 3-wire or 4-wire circuit				
Measuring current	approx. 250μA				
Lead compensation	Not required for 3-wire or 4-wire circuit. With a 2-wire circuit, the lead resistance can be compensated in software by a correction of the process value.				

Input for standard signals

Designation	Measuring range	Measuring accuracy	Ambient temperature error
Voltage	0(2) – 10V	≤0.05%	100 ppm / °C
	0 – 1V input resistance $R_{IN} > 100k\Omega$	≤0.05%	100 ppm / °C
Current	0(4) – 20mA, voltage drop 2.0 – 2.5 V	≤0.05%	100 ppm / °C
Heating current	0 – 50mA AC	≤20%	100 ppm / °C
	0 – 20mA DC	≤1%	100 ppm / °C
Resistance transmitter	min. 100Ω, max. 4kΩ	≤0.5%	100 ppm / °C

Binary inputs

Floating contacts	
-------------------	--

12 Appendix

Measuring circuit monitoring

In the event of a fault, the outputs move to a defined (configurable) status.

Sensor	Overrange / underrange	Probe or lead short-circuit	Probe or lead break
Thermocouple	•	-	•
Resistance thermometer	•	•	•
Voltage 2 – 10V	•	•	•
0 – 10V	•	-	-
0 – 1V	•	-	-
Current 4 – 20mA	•	•	•
0 – 20mA	•	-	-
Resistance transmitter	-	-	•

• = recognized - = not recognized

Outputs

Relay (changeover, SPDT) for type 703046/48 contact rating contact life	5A at 230VAC resistive load 350,000 operations at rated load / 750,000 operations at 1A
Relay (changeover, SPDT) (option) contact rating contact life	8A at 230V AC resistive load 100,000 operations at rated load / 350,000 operations at 3A
Relay (make, SPST-NO) for type 703045 contact rating contact life	3A at 230VAC resistive load 150,000 operations at rated load / 350,000 at 1A
Relay (make, SPST-NO) (option) contact rating contact life	3A at 230VAC resistive load 350,000 operations at rated load / 900,000 operations at 1A
Logic output	0/12V / 30mA max. (sum of all output currents) or 0/18V / 25mA max. (sum of all output currents)
Solid-state relay (option) contact rating protection circuitry	The holding current of the triac is at least 50mA 1A at 230V varistor
Voltage (option) output signals load resistance accuracy	0 – 10V / 2 – 10V $R_{load} \geq 500\Omega$ $\leq 0.5\%$
Current (option) output signals load resistance accuracy	0 – 20mA / 4 – 20mA $R_{load} \leq 500\Omega$ $\leq 0.5\%$
Supply voltage for 2-wire transmitter for Type 703046/48 voltage	electrically isolated, not stabilized 17V at 20mA load, 25V DC with no load

Controller

Controller type	2-state controller (factory setting), 3-state controller, modulating controller, continuous controller
Controller structures	P/PD/PI/PID
A/D converter	dynamic resolution up to 16-bit
Sampling cycle time	50msec, 90msec, 150msec, 250msec (factory setting: 250msec)

Electrical data

Supply voltage (switchmode PSU)	110 – 240V AC -15/+10%, 48 – 63Hz 20 – 30V AC/DC, 48 – 63Hz																								
Electrical safety	Type 703045: acc. to DIN EN 61010-1:2020 Type 703046/48: acc. to DIN EN 60730-1:2011 Overvoltage category III, pollution degree 2																								
Power consumption	13VA max.																								
Data backup	EEPROM																								
Electrical connection	at the back, via screw terminals, conductor cross-section up to 2.5mm ² with core ferrules (length: 10 mm) Conductor cross-sections and core-end ferrules for installation																								
	<table border="1"> <thead> <tr> <th></th> <th>Minimum cross-section</th> <th>Maximum cross-section</th> <th>Min. length of core-end ferrule</th> </tr> </thead> <tbody> <tr> <td>Without core-end ferrule</td> <td>0.34mm²</td> <td>2.5mm²</td> <td>10mm (stripped)</td> </tr> <tr> <td>Core-end ferrule, no lip</td> <td>0.25mm²</td> <td>2.5mm²</td> <td>10mm</td> </tr> <tr> <td>Core-end ferrule, lip up to 1.5mm²</td> <td>0.25mm²</td> <td>1.5mm²</td> <td>10mm</td> </tr> <tr> <td>Core-end ferrule, lip above 1.5mm²</td> <td>1.5mm²</td> <td>2.5mm²</td> <td>12mm</td> </tr> <tr> <td>Twin ferrule with lip</td> <td>0.25mm²</td> <td>1.5mm²</td> <td>12mm</td> </tr> </tbody> </table>		Minimum cross-section	Maximum cross-section	Min. length of core-end ferrule	Without core-end ferrule	0.34mm ²	2.5mm ²	10mm (stripped)	Core-end ferrule, no lip	0.25mm ²	2.5mm ²	10mm	Core-end ferrule, lip up to 1.5mm ²	0.25mm ²	1.5mm ²	10mm	Core-end ferrule, lip above 1.5mm ²	1.5mm ²	2.5mm ²	12mm	Twin ferrule with lip	0.25mm ²	1.5mm ²	12mm
	Minimum cross-section	Maximum cross-section	Min. length of core-end ferrule																						
Without core-end ferrule	0.34mm ²	2.5mm ²	10mm (stripped)																						
Core-end ferrule, no lip	0.25mm ²	2.5mm ²	10mm																						
Core-end ferrule, lip up to 1.5mm ²	0.25mm ²	1.5mm ²	10mm																						
Core-end ferrule, lip above 1.5mm ²	1.5mm ²	2.5mm ²	12mm																						
Twin ferrule with lip	0.25mm ²	1.5mm ²	12mm																						
Electromagnetic compatibility interference emission interference immunity	acc. to DIN EN 61326-1:2013 Class B to industrial requirements																								

Housing

Housing type	plastic housing for panel mounting to IEC 61554
Depth behind panel	90 mm
Ambient/storage temperature range	0 to 55°C / -30 to +70°C
Climatic conditions	rel. humidity ≤90% annual mean, no condensation
Operating position	horizontal
Enclosure protection	to EN 60529, front IP65 / back IP20
Weight (fully fitted)	Type 703045: approx. 220g Type 703046: approx. 380g Type 703048: approx. 490g

Interface

Modbus

Interface type	RS422/485
Protocol	Modbus, Modbus Integer, Modbus Master
Baud rate	4800, 9600, 19200, 38400
Device address	0 – 255
Max. number of nodes	32

PROFIBUS-DP

Device address	0 – 255
----------------	---------

TTY current interface

Interface type	Current 0/20mA
Protocol	Arburg
Baud rate	4800, 9600, 19200, 38400
Device address	0 – 255
Max. no of nodes	depending on the current source or their voltage supply; voltage drop per device: approx. 2.5V at 20mA

12 Appendix

Approvals/marks of conformity

Mark of conformity	Testing laboratory	Certificates/certification numbers	Test basis	valid for
c UL us	Underwriters Laboratories	E 201387	UL 61010-1 CAN/CSA-C22.2 No. 61010-1	all types

12.2 Alarm messages

Display	Cause	Fault removal test/repair/replace
- 1999 (blinking!)	Underrange for the value being displayed.	<ul style="list-style-type: none"> - Check that the connected probe complies with the configured sensor type and linearization - Check the probe connection and the terminals - Check the cable - Check probe for short-circuit and probe break - In case of standard signal: Is the signal within the permissible range (e.g. 4 - 20mA)?
9999 (blinking!)	Overrange for the value being displayed.	
9999 (lower display)	Error in output feedback of modulating controller	Check the source signal for output feedback
---- (blinking!)	Source signal for controller process value is switched off	Select a source signal in configuration level
all displays on; lower 7-segment display is blinking	Watchdog or power-on trigger initialization (reset).	Replace the controller if the initialization continues for more than 5sec
PROF	PROFIBUS error	Can be suppressed by setting the PROFIBUS address to "0" (if PROFIBUS interface is not used).
OPT	Hardware configuration error	Check which option boards are installed in the slots

Overrange / underrange covers the following events:

- Probe break or short-circuit
- Measurement is outside the controllable range for the probe that is connected
- Display overflow

A

Access code *39*
Accessories *10*
Acknowledgement *61*
Analog input *41*
Analog marker *72*
Analog selector *40*

B

Baud rate *72*
Binary functions *65*
Binary marker *72*
Binary output *63*
Boost function *54*
Brightness *69*

C

Connection diagrams *17*
Control action *47, 71–72*
Control contacts *56*
Control loop monitoring *50*
Controller *47*
Controller module, removing *14*
Controller standby output *48*
Controller type *47, 63, 66, 71*

D

Data format *72*
Decimal point *69*
Delay time *56*
Device address *72*
Difference control *79*
Dimensions *11*
Display *69*
Display end *42*
Displays *25*

E

Electrical isolation *16*
End value *64*

F

Filter time constant *42*
Fine tuning *42*
Fitting *14*
Formula, entering *79*
Front panel, care of *14*

H

Heater current monitoring *43*

Hot-channel *57*
Humidity control *80*

I

Installation notes *15*
Interface *72*

L

Level concept *26*
Level inhibit *27, 69*
Limit comparator *58*
Limit comparator functions *58*
Limit value *59*
Linearization *41*

M

Manual mode *29, 47, 64*
Manual mode, inhibiting *47*
Manual output *47*
Measurement offset *42*
Modbus master *73*
Module
 identification *81*
 retrofitting *81*
Mounting site *11*

O

Output level monitoring *52*
Outputs *62*
 numbering *62*

P

Parameter level *37*
Parameter set switching *66*
Password *39*
PC interface *10*
Process data *35*
Program editor *10*
Program profile, shifting *33*
Program start *56*
Program, entering *30*
Protocol *72*
Pulse time *61*

R

Ramp slope *56*
Range output *47*
Ratio control *80*
Reduction function *68*

13 Index

S

Safety notes *81*
Sampling cycle time *44*
Scope of delivery *10*
Self-tuning (self-optimization) *48, 75*
Sensor type *41*
Setpoint *35*
 external *48*
Setpoint limits *47*
Setpoint switching *66*
Setup program *10*
Side-by-side mounting *13*
Signal type *64*
Step response method *75*
Step size *48*
Supply frequency *44*
Switching action *65*
Switching differential *59*
Switch-on delay *60*

T

Text display *66*
Time-out *69*

Timer *71*
 setting *71*
Times, entering *28*
Tolerance band *56, 71*
Tuning (optimization) *78*
Type designation *9*

U

Unit *56*
 temperature *44*
User data *26*

V

Values, entering *28*

W

Warm-up ramp *57*

Z

Zero point *64*

Overview of the configuration level

InP Page 41	InP 1 InP2	SEn5	Sensor type
		Lin	Linearization
		OFFS	Measurement offset
		SCL	Display start
		SEH	Display end
		dF	Filter time constant
		FtS	Fine tuning start value
		FtE	Fine tuning end value
		HEARt	Heater current monitoring
	InP i2	Unit	Temperature unit
		Cycl	Sampling cycle time
Ctrlr Page 47		CTYP	Controller type
		CRct	Control action
		InHbA	Inhibit manual mode
		MANd	Manual output
		rOut	Range output
		SPL	Setpoint low
		SPH	Setpoint high
		CPv	Controller process value
		ESP	External setpoint
		FEEd	Output feedback
		tYPt	Method of tuning
		InHt	Inhibit tuning
		Out 1	Output of tuning 1
		Out 2	Output of tuning 2
		SOUt	Controller standby output
		StS 1	Step size
		InHC	Control loop monitoring
		tC	Response time
		tolC	Monitoring band
		InHY	Output level monitoring
		tY	Determination time
		tolY	Monitoring band
		tOnY	Alarm trigger delay
		dIFb	Control difference band
		Fctb	Boost function
		boSt	Boost value
Pro Page 55		Fncf	Function
		Unit	Unit of slope
		rASL	Ramp slope
		tolP	Tolerance band
LC Page 58	LC 1 LC2 LC3 LC4	Fncf	Function
		AL	Limit value
		HYSd	Switching differential
		AcRr	Action/range response
		tOn	Switch-on delay
		tOFF	Switch-off delay
		AcnL	Acknowledgement
		tPUL	Pulse time
		LCPr	Limit comparator PV
		LCSP	Limit comparator SP
OutP Page 62	OutL OutR	Out 1	Binary output 1
	
		Out 10	Binary output 10
		Out 5	Analog output 5
		Fncf	Function
		Si, Sn	Type of signal
		rOut	Range output
		OPnt	Zero point
		End	End value
	
		Out 7	Analog output 7
bInF Page 65	bIn 1 ... bIn 8 LC 1	bIn 1	Binary input 1
	
		bIn 8	Binary input 8
		LC 1	Limit comparator 1
	
		LC 4	Limit comparator 4
		tF 1	Timer 1
		tF 2	Timer 2
		Lo 1	Logic 1
		Lo 2	Logic 2
		CC 1	Control contact 1
	
		CC 4	Control contact 4
		tolS	Tolerance limit signal
		PrES	Program end signal
		CLoS	Control loop monitoring signal
		OLEs	Output level monitoring signal
dSP Page 69	dS 1 dS 2 dEcP br, 6 dS 3 tOut	dS 1	Upper display
		dS 2	Lower display
		dEcP	Decimal point
		br, 6	Brightness
		dS 3	16-segment display
		tOut	Time out

tFct Page 71	tF1 tF2	Fnct t tol	Function Timer time Tolerance limit
intF Page 72	PrdF	Prot Adr AnAP bi AP	Protocol Device address Analog marker Binary marker
	r422	Prot bdr dFt Adr	Protocol Baud rate Data format Device address



JUMO GmbH & Co. KG

Street address:
Moritz-Juchheim-Straße 1
36039 Fulda, Germany

Delivery address:
Mackenrodtstraße 14
36039 Fulda, Germany

Postal address:
36035 Fulda, Germany

Phone: +49 661 6003-0
Fax: +49 661 6003-607
Email: mail@jumo.net
Internet: www.jumo.net

JUMO Instrument Co. Ltd.

JUMO House
Temple Bank, Riverway
Harlow, Essex, CM20 2DY, UK

Phone: +44 1279 63 55 33
Fax: +44 1279 62 50 29
Email: sales@jumo.co.uk
Internet: www.jumo.co.uk

JUMO Process Control, Inc.

6724 Joy Road
East Syracuse, NY 13057, USA

Phone: +1 315 437 5866
Fax: +1 315 437 5860
Email: info.us@jumo.net
Internet: www.jumousa.com

