

Explosion proof type indicating temperature switch

Model : T990

Spec. sheet no. TD09-05

Service intended

This temperature switch is installed with a micro contact, and it is suitable for measuring the temperature of corrosive fluid. Dead band is fixed.



Ambient temperature

-20 ~ 60 °C

Nominal diameter

125 mm

Repeatability

±1.0 % of adjustable range

Accuracy

±2.0 % of full scale

Measuring system (SAMA class IIIB)

Gas : -200 ~ 700 °C

Working range

Maximum scale value



Standard features

Location of stem

Bottom connection, surface,
Case mounting

Case

Silver gray finished

Cover

Silver gray finished

Capillary

Capillary : 1.6/0.2 mm, 316SS
Armored tube : 7.5/5.5 mm, 304SS

Switch form

Micro contact type
One SPDT or Two SPDT
One DPDT

Contact rating

- AC 125 V/250 V, 15 A and DC 30 V, 2 A
DC 125 V, 0.5 A for resistance load
- AC 125 V/250 V, 15 A and DC 30 V, 1 A
DC 125 V, 0.05 A for inductive load

Stem

8.0, 10.0 and 12.0 mm
316SS and 316L SS

Stem, process connection

3/8", 1/2", 3/4" PT, NPT and PF

Optional

Special accuracy, ±1.0 % of full scale

Certificates

KCS Ex d IIB+H2 T6

Main order

Ordering information

1. Base model

T990 Explosion proof type indicating temperature switch

2. Stem material

- 1 316SS
- 2 316L SS

3. Mounting

B Bottom connection, surface, case mounting

4. Alarm type

- 1 High
- 2 Low
- 3 High and low
- 4 High and hihigh
- 5 Low and lolow

5. Stem, process connection

- A** None
- D** 3/8"
- E** 1/2"
- F** 3/4"

6. Stem connection type (CF: Compression fitting)

- A** None
- E** CF + PT
- F** CF + NPT
- G** CF + PF
- H** MT + PT (Movable thread)
- I** MT + NPT (Movable thread)
- J** MT + PF (Movable thread)

7. Stem outer diameter (mm)

- 2** 8.0
- 3** 10.0
- 4** 12.0 (Standard)
- Z** Other

8. Range

XXX Refer to scale range table

9. Capillary length (m)

- P** 2
- Q** 3
- S** 5
- V** 8
- X** 10
- Z** Other

10. Accessories

- 0** None
- 1** Thermowell
- 2** Special accuracy ($\pm 1.0\%$ of full scale)
- 3** Thermowell and special accuracy

Sample ordering code

1	2	3	4	5	6	7	8	9	10
T990	5	B	1	E	C	3	XXX	P	1

T990 : Type of mounting

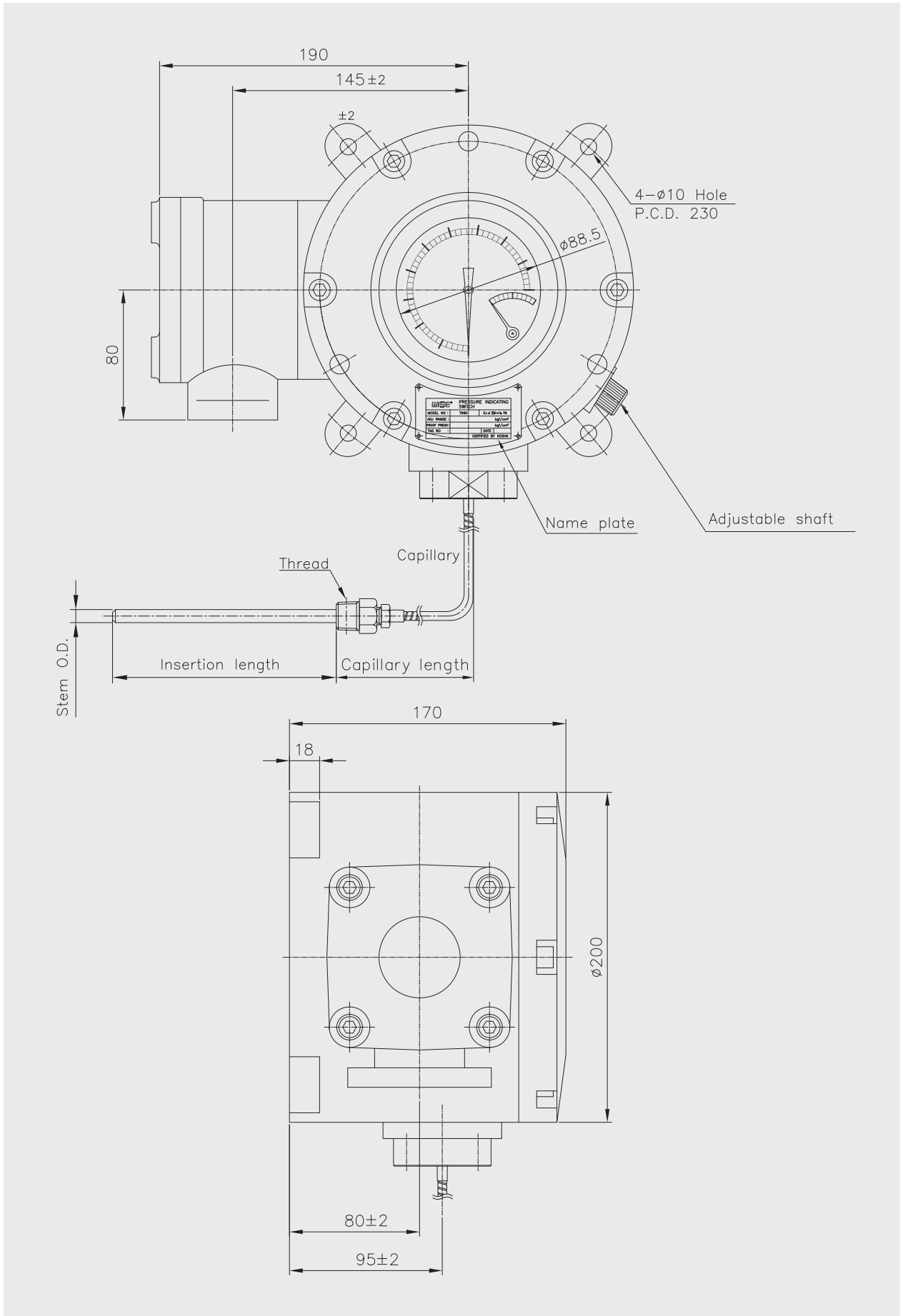

Temperature switch

A bi-stable electro-mechanical device that actuates/deactuates one or more electrical switching element at a predetermined discrete temperature upon rising or falling.

Adjustable range

The span of temperature between upper and lower limited within which the temperature switch can be adjusted to actuate/deactuate.

It is expressed for increasing temperature.

Setpoint

That discrete temperature at which the temperature switch is adjusted to actuate/deactuate on rising or falling temperature. It must fall within the adjustable range and be called out as increasing.

Dead band

The difference in temperature between the increasing setpoint and decreasing set point.

Proof pressure

The maximum input pressure that can be continuously applied to the pressure switch without causing permanent change of set point, leakage or falling, material failure.

Burst temperature

The maximum input temperature that can be continuously applied to the temperature switch without causing leakage or catastrophic material failure. Permanent change of set point may occur, or the device may be rendered inoperative.

Repeatability

The ability of a temperature switch to successively operate at a setpoint that is approached from a starting point in the same direction and returns to the starting point over three consecutive cycles to establish a temperature profile.

Temperature range table

Code	Scale range (°C)	Scale spacing(°C)	Minimum stem length (mm)			Standard stem length (mm)		
			8.0	10.0	12.0	8.0	10.0	12.0
032	-50 ~ 50	2	100	85	65	200	130	100
037	-50 ~ 100	5	100	88	65	200	130	100
054	-30 ~ 50	2	100	85	65	200	130	100
059	-30 ~ 100	2	100	85	65	200	130	100
061	-30 ~ 120	5	100	85	65	200	130	100
069	-20 ~ 50	2	100	85	65	200	130	100
074	-20 ~ 100	2	100	85	65	200	130	100
079	-20 ~ 150	5	100	85	65	200	130	100
084	-10 ~ 50	1	100	85	65	200	130	100
099	0 ~ 50	1	100	85	65	200	130	100
100	0 ~ 60	1	100	85	65	200	130	100
101	0 ~ 70	2	100	85	65	200	130	100
102	0 ~ 80	2	100	85	65	200	130	100
104	0 ~ 100	2	100	85	65	200	130	100
106	0 ~ 120	2	100	85	65	200	130	100
109	0 ~ 150	5	100	85	65	200	130	100
114	0 ~ 200	5	100	85	65	200	130	100
119	0 ~ 250	5	100	85	65	200	130	100
124	0 ~ 300	5	100	85	65	200	130	100
129	0 ~ 350	5	100	85	65	200	130	100
134	0 ~ 400	10	100	85	65	200	130	100
144	0 ~ 500	10	100	85	65	200	130	100
154	0 ~ 600	10	100	85	65	200	130	100
164	0 ~ 700	10	100	85	65	200	130	100

* 0 ~ 700 °C/Special range

Insertion length

Code	1	2	3	4	5	6	7	8	9	A	B	C
Length (mm)	50	60	70	80	100	120	130	150	175	200	225	250

Code	D	E	F	G	H	J	K	L	M	N	P
Length (mm)	275	300	350	375	400	450	500	550	1,000	1,500	2,000

Rated voltage	Resistance load		Inductive load	
	NC	NO	NC	NO
125 V AC	15 (10)		15 (10)	
250 V AC	15 (10)		15 (10)	
480 V AC	10		10	
8 VDC	15		15	
14 V DC	15		10	
30 V DC	2		1	
125 V DC	0.4		0.03	
250 V DC	0.2		0.02	

SPDT switching element

Single-pole, double throw (SPDT) has three connection: C-common, NO-normally open and NC-normally closed, which allows the switching element to be electrically to the circuit NO or NC state.

DPDT switching element

Double-pole, double throw (DPDT) is two SPDT switching elements operated by a common lever assembly so simultaneous actuation/deactuation occurs at both the increasing and the decreasing set point. Two independent electrical circuits can be switched, i.e. one AC and one DC.

Single type

When the input pressure reach the upper or lower limit setpoint. The circuit is closed and opened.

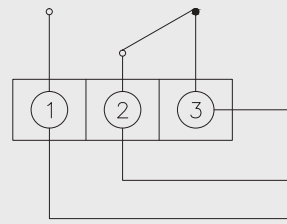

①:N.O ②:COM ③:N.C

Double type

When the input pressure reach the upper or lower limit setpoint. Two circuit are simultaneously closed and opened.

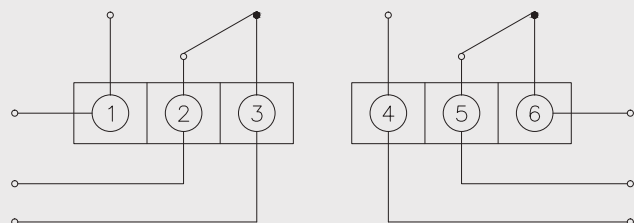

①,④:N.O ②,⑤:COM ③,⑥:N.C

N.O : Normal open
N.C : Normal close

Empty rectangular box for memo content.