

Sanitary pressure gauge (3-A marking)

Model: P752S series

Spec. sheet no. PD07-05

Service intended

P752S series have diaphragm seal to be combined with a pressure gauge. These series are suitable to be used for the situation where corrosive, contaminated, hot, and viscous pressure mediums are present, and it could be used for a chemical, food, beverage, biochemical, and pharmaceutical industry.



Special features

3-A certificated
Suitable for SIP and CIP
All stainless steel and welded construction
Flush, aseptic process connection
Rotatable retainer DRD Flange

Nominal diameter

50, 63, 80 and 100 mm

Accuracy

P752 (50 mm) : ± 3.0 % of full scale
P752 (63 mm) and P752 (80 mm) : ± 1.6 % of full scale
P752 (100 mm) : ± 1.0 % of full scale

Scale range

-0.1 ~ 7 MPa

Working pressure

Steady pressure : 75 % of full scale value
Fluctuating pressure : 67 % of full scale value

Working temperature

Ambient : -25 ~ 65 °C
Fluid : Max.121 °C

Temperature effect

Accuracy at temperature above and below the reference temperature (20 °C) will be effected by approximately ± 0.5 % per 10 °C of full scale



Standard features

Process connection

$\frac{3}{4}$ ", 1", 1 $\frac{1}{2}$ " and 2"
Low and back

Diaphragm and process connection

Diaphragm : 316L SS, Hastelloy C276
Process connection(Body) : 316/L SS, Hastelloy C276
Surface roughness : $\leq Ra : 0.7 \mu m$

Case

Stainless steel (304SS)
Electropolished with pressure relief

Cover

50 mm : Twist-lock polycarbonate (Diameter 50 mm)
63, 80 and 100 mm : Stainless steel 304SS

Window

Safety glass (63, 80 and 100 mm)
Polycarbonate (50 mm)

Movement

Stainless steel

Dial

White aluminium with black and red graduations, dual pressure scale

Pointer

Black painted aluminium alloy

Helium leak rate

Tested to confirm leakage rates of less than 10^{-6} mbar $\cdot \ell$ /sec

System filling

Food grade oil (FDA certified)

Option

Material of wetted parts : electropolished 316L SS

WISE[®]

1. Base model**P752S** Sanitary pressure gauge (3-A marking)**2. Nominal diameter and mounting type**

- 1A** P221 50 mm, bottom connection (refer to code A)
- 7A** P252 63 mm, bottom connection (refer to code A)
- 7G** P252 63 mm, lower back connection (refer to code G)
- 7P** P258 63mm, bottom connection (refer to code A)
- 7T** P258 63 mm, lower back connection (refer to code G)
- 7U** P252 80 mm, bottom connection (refer to code A)
- 7V** P252 80 mm, lower back connection (refer to code G)
- 8U** P258 80 mm, bottom connection (refer to code A)
- 8V** P258 80 mm, lower back connection (refer to code G)
- 8A** P252 100 mm, bottom connection (refer to code A)
- 8G** P252 100 mm, lower back connection (refer to code G)
- 8P** P258 100 mm, bottom connection (refer to code A)
- 8T** P258 100 mm, lower back connection (refer to code G)

3. Process connection(Body) material

- D** 316L SS, only available with Tri-clamp
- F** 316L SS (1.4435), only available with Retainer and DRD Flange
- P** Hastelloy C276, only available with Tri-clamp

4. Process connection

- F** ¾" Tri-clamp, only available with diameter 50 mm
- G** 1" Tri-clamp, only available with diameter 63,80 and 100 mm
- J** 1½" Tri-clamp, only available with diameter 63,80 and 100 mm
- K** 2" Tri-clamp, only available with diameter 63,80 and 100 mm
- R** Retainer flange, only available with diameter 63, 80 and 100 mm
- S** Retainer flange and DRD Flange (DN50), only available with diameter 63, 80 and 100 mm

5. Unit

- H** bar
- I** MPa
- J** kPa

6. Range**XXX** Refer to pressure range table**7. Diaphragm material**

- E** 316L SS
- G** Hastelloy C276, only available with Tri-clamp

8. Option

- 0** None
- 1** Accessories

Sample ordering code

1	2	3	4	5	6	7	8
P752S	1A	D	F	H	XXX	E	0

P752S : Type of mounting

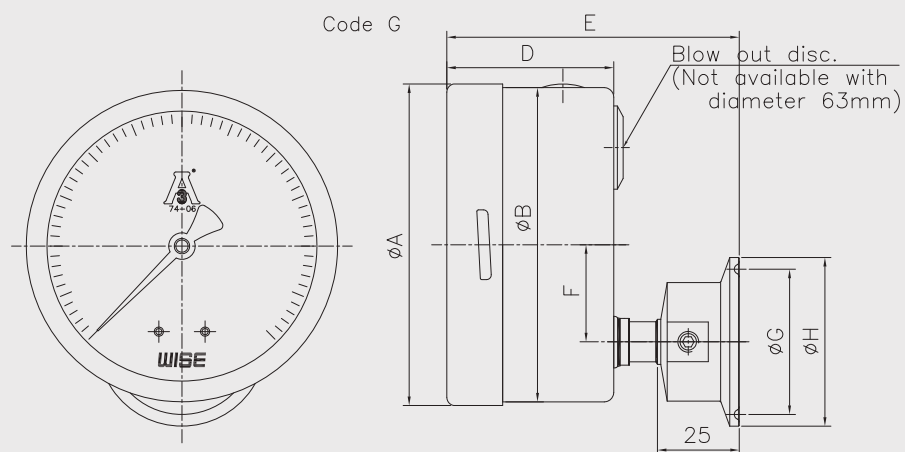
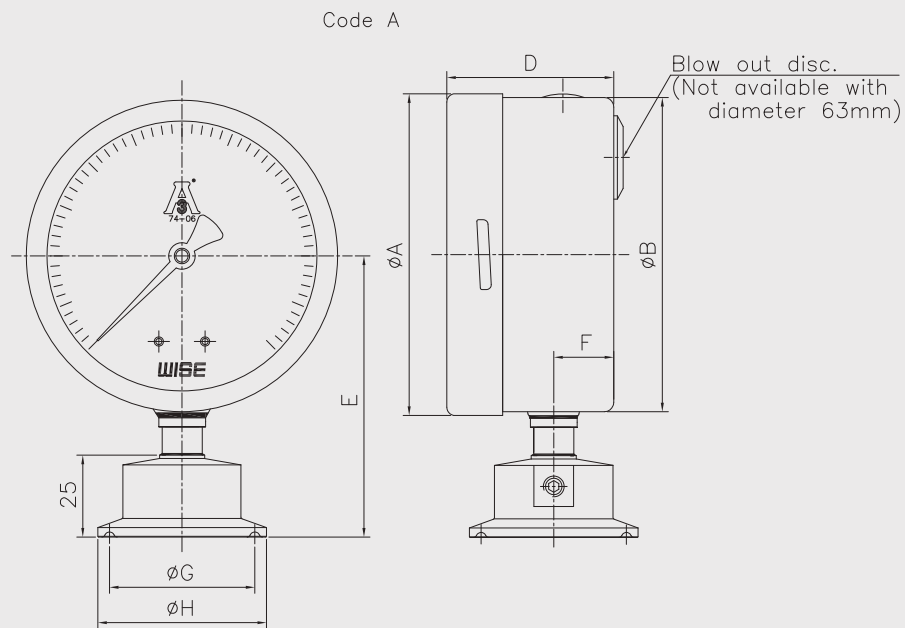

Dimensions (mm)									
Dial size	Clamp type	Available code	A	B	D±2	E±2	F±1	G	H
50	3/4"	A	53	50.8	29	68.3	9	19.5	25
	1"								
	1 1/2"								
63	2"	A	64	62	33	75.7	11	56.5	64
	1"								
	1 1/2"								
	2"	G	64	62	33	82.5	13	43.5	50.5
	1"								
	1 1/2"								
80	2"	A	81.2	78.5	39.5	84	12	56.5	64
	1"								
	1 1/2"								
	2"	G	81.2	78.5	39.5	91	22	43.5	50.5
	1"								
	1 1/2"								
100	2"	A	101.3	99	50	100	16	56.5	64
	1"								
	1 1/2"								
	2"	G	101.3	99	50	106.5	24	43.5	50.5
	1"								
	1 1/2"								

P752F: Type of mounting

Assembly by DRD flange and retainer flange

Code A

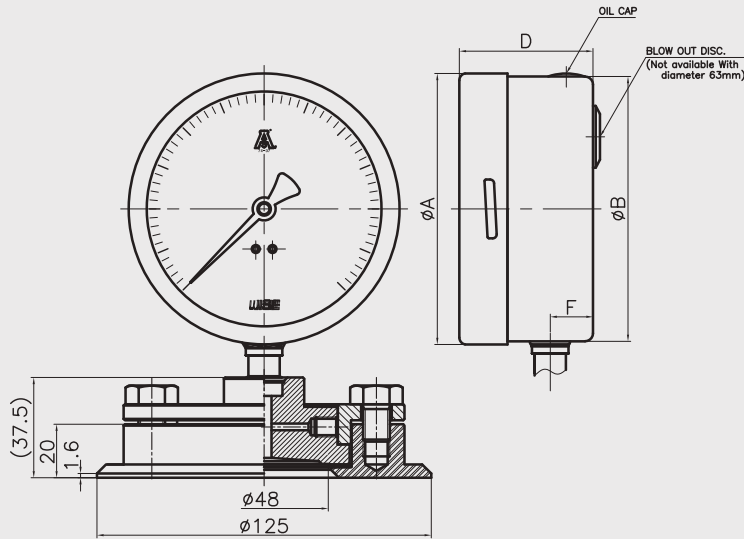

Code G

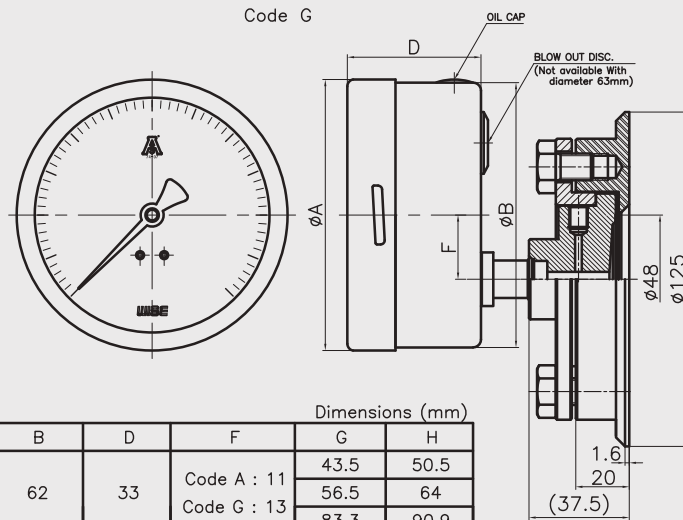

Dial size	Clamp type	Dimensions (mm)					
		A	B	D	F	G	H
63	1 1/2"	64	62	33	Code A : 11	43.5	50.5
	2"				Code G : 13	56.5	64
	3"				83.3	90.9	
80	1 1/2"	81.2	78.5	39.5	Code A : 12	43.5	50.5
	2"				Code G : 22	56.5	64
	3"				83.3	90.9	
100	1 1/2"	101.3	99	50	Code A : 16	43.5	50.5
	2"				Code G : 24	56.5	64
	3"				83.3	90.9	

DRD flange (DN50)

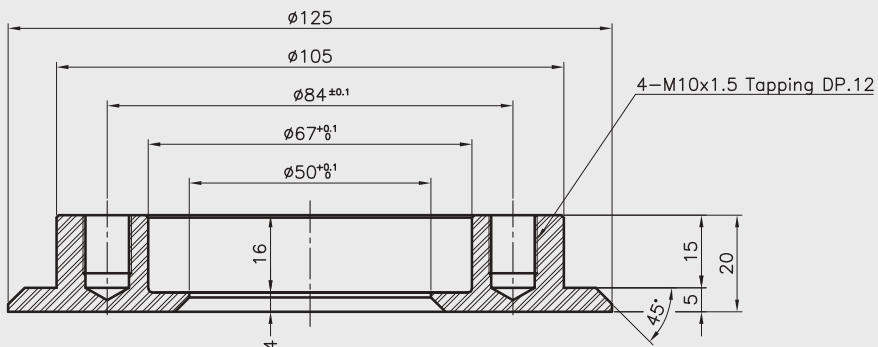

Range table

Range and code	Unit and code			Pressure connection			
	H : bar	I : MPa	J : kPa	¾"	1"	1½"	2"
026	-1 ~ 0	-0.1 ~ 0	-100 ~ 0	X	X	O	O
041	0 ~ 1	0 ~ 0.1	0 ~ 100	X	O	O	O
042	0 ~ 2	0 ~ 0.2	0 ~ 200	O	O	O	O
134	0 ~ 2.5	0 ~ 0.25	0 ~ 250	X	O	O	O
043	0 ~ 3	0 ~ 0.3	0 ~ 300	O	O	O	O
044	0 ~ 4	0 ~ 0.4	0 ~ 400	O	O	O	O
045	0 ~ 6	0 ~ 0.6	0 ~ 600	O	O	O	O
047	0 ~ 10	0 ~ 1	0 ~ 1,000	O	O	O	O
050	0 ~ 15	0 ~ 1.5	X	O	O	O	O
143	0 ~ 16	0 ~ 1.6	X	O	O	O	O
051	0 ~ 20	0 ~ 2	X	O	O	O	O
052	0 ~ 25	0 ~ 2.5	X	O	O	O	O
054	0 ~ 35	0 ~ 3.5	X	O	O	O	O
151	0 ~ 40	0 ~ 4	X	X	O	O	O
055	0 ~ 50	0 ~ 5	X	X	O	O	O
056	0 ~ 60	0 ~ 6	X	X	O	O	O
027	-1 ~ 1	-0.1 ~ 0.1	-100 ~ 100	X	X	O	O
127	-1 ~ 1.6	-0.1 ~ 0.16	-100 ~ 160	X	X	O	O
028	-1 ~ 2	-0.1 ~ 0.2	-100 ~ 200	X	X	O	O
129	-1 ~ 2.5	-0.1 ~ 0.25	-100 ~ 250	X	X	O	O
029	-1 ~ 3	-0.1 ~ 0.3	-100 ~ 300	X	X	O	O
030	-1 ~ 4	-0.1 ~ 0.4	-100 ~ 400	X	X	O	O
010	-1 ~ 5	-0.1 ~ 0.5	-100 ~ 500	X	X	O	O
031	-1 ~ 6	-0.1 ~ 0.6	-100 ~ 600	X	X	O	O
014	-1 ~ 9	-0.1 ~ 0.9	-100 ~ 900	X	X	O	O
032	-1 ~ 10	-0.1 ~ 1	-100 ~ 1,000	X	X	O	O
033	-1 ~ 15	-0.1 ~ 1.5	X	X	X	O	O
034	-1 ~ 20	-0.1 ~ 2	X	X	X	O	O
035	-1 ~ 25	-0.1 ~ 2.5	X	X	X	O	O

O : Available X : Not available

Large empty rectangular area for writing or drawing.