

**OPERATING INSTRUCTIONS MANUAL**codice: **81085A_05-2024 - ENG****ATTENTION!**

This manual must always be available to operators of the devices described here.

Always make sure that you have the latest version of the manual, which is available for free download from the GEFTRAN website (www.gefran.com).

Installers and/or maintenance personnel are required to read this manual and to precisely follow the instructions contained in it and in its attachments.

GEFRAN will not be liable for any damage to persons and/or property, or to the product itself, caused by failure to follow the instructions and observe the warnings given below.



This manual and its attachments may be freely reproduced as long as they are not changed in any way and every copy contains this warning and the declaration of ownership by Gefran S.p.A.

REVISION DOCUMENTS

DATE	CODE	UPDATE	N. pages of the document

Copyright © 2018 Gefran Soluzioni

Subject to change without notice

The information contained in this document is provided for informational purposes only. While efforts were made to verify the accuracy of the information contained in this documentation, it is provided "as is" without warranty of any kind.

Third-party brands and names are the property of their respective owners.

www.gefran.com/en/gefran-soluzioni

TABLE OF CONTENTS

1. PRODUCT OVERVIEW.....	5
2. STANDARDS AND APPROVALS	5
3. TECHNICAL SPECIFICATIONS.....	7
4. TECHNICAL DATA.....	9
4.1. Dimensions.....	10
4.2. Installation Environment	11
4.3. Safety instruction	11
4.4. Installation Procedure.....	11
5. CONNECTIONS.....	12
5.1. Serial Port.....	12
5.2. Ethernet Port	13
5.3. Optional plugin module.....	13
5.4. Optional plugin module installation procedure.....	14
6. POWER SUPPLY, GROUNDING AND SHIELDING.....	15
7. BATTERY	16
8. SPECIAL INSTRUCTION FOR USE	16
9. GETTING STARTED	16
10. SYSTEM SETTINGS.....	17
11. UNPACKING AND PACKING INSTRUCTIONS.....	19

INTRODUCTION

The operational guidelines described below is information which relates to the device, installation, transportation, storage, assembly, use and maintenance.

This Operating Instruction describes the main features of the Gefran Soluzioni srl operator panels. The Manual refers to the following models:

- G-Mation V45-070** Operator interface with TFT color 7" widescreen display multitouch projected capacitive touchscreen
- G-Mation V45-101** Operator interface with TFT color 10.1" widescreen display multitouch projected capacitive touchscreen
- G-Mation V45-156** Operator interface with TFT color 15.6" widescreen display multitouch projected capacitive touchscreen
- G-Mation V45-215** Operator interface with TFT color 21.5" widescreen display multitouch projected capacitive touchscreen

SAFETY GUIDE

The manual contains safety standards that must be respected for the personal safety and to avoid damage.

Indications of attention are divided into three levels of severity:



DANGER: indicates a failure to observe safety rules and such failure may cause death or serious injuries.



ATTENTION: indicates a failure to observe safety rules and that deficiency may cause damage.



CAUTION: indicates a failure to observe safety rules and that deficiency may cause defects to the equipment or inconsistencies.

1. PRODUCT OVERVIEW

G-Mation V45 HMI products combine state-of-the-art connectivity features and top performance in a great design. Products have been designed as IoT edge devices with the combination of a powerful controller with networking capability (up to 3 Ethernet networks) and outstanding communication options including client/server OPC UA. They are the ideal choice for all demanding IoT edge applications in factory, and for machine control.

The glass projected capacitive touchscreen and the brilliant displays with size up to 21.5” and resolution up to 1920x1080

guarantee great optical performance; with the support of multitouch gesture programming they can create the most natural human interfaces.

- G-Mation V45 products have been designed to run the GF Designer HD software for powerful HMI applications.
- Gateway function with OPC UA Server and Client.
- Secure connectivity with Gefran Cloud and full network separation.
- Powerful browser with industry standard Web engines.

2. STANDARDS AND APPROVALS

The products have been designed for use in an industrial environment in compliance with the 2014/30/EU EMC Directive.

The products have been designed in compliance with:

EN 61000-6-4 CISPR 22 Class A
 CISPR 16-2-3

EN 61000-6-2 EN 61000-4-2
 EN 61000-4-3
 EN 61000-4-4
 EN 61000-4-5
 EN 61000-4-6
 EN 61000-4-8
 EN 61000-4-11
 EN 61000-4-29

EN60945

UL cULus: UL61010-1 / UL61010-2-201
 cULus: Class 1 Div 2

The installation of these devices into the residential, commercial and light-industrial environments is allowed only in the case that special measures are taken in order to ensure conformity to EN 61000-6-3.

The products are in compliance with the Restrictions on Certain Hazardous Substances (RoHS) Directive 2011/65/EU

In compliance with the above regulations the products are CE marked.

Product Identification

The product may be identified through a plate attached to the rear cover. You will have to know the type of unit you are using for correct usage of the information contained in the guide.

An example of this plate is shown in the figure below:

Note: the G-Mation V45 label is used as an example for G-Mation V45 Series

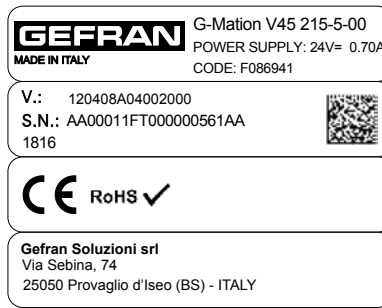
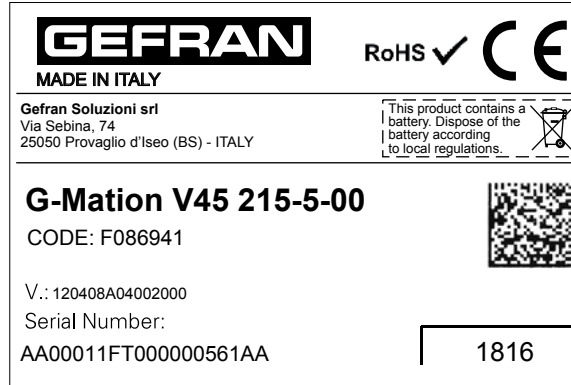

Product model name	G-Mation V45 215-5-00
Code:	F086941
Year/week of production	1816
Serial Number	AA00011FT000000561AA
Version id of the product	120408A04002000
Manufacturer address	Gefran Soluzioni srl Via Sebina 74 25050 Provaglio D'Iseo (Bs) - Italy

3. TECHNICAL SPECIFICATIONS

Touchscreen technology	Projected capacitive	
Back-up battery	3V 50mAh Lithium, rechargeable, not user-replaceable, model VL2330.	
Fuse	Automatic	
Serial Port	RS-232, RS-485, RS-422 software configurable	
Flash	4GB	
RAM	2GB	
Hardware clock	Clock/Calendar with back-up battery	
Accuracy RTC (at 25°C)	<100ppm	
ENVIRONMENTAL CONDITIONS		
Operating temperature (surrounding air temperature)	-20 ÷ +60°C (vertical installation) Plug-in modules and USB devices may limit max temperature to +50°C	EN 60068-2-14
Storage temperature	-20 ÷ +70°C	EN 60068-2-1 EN 60068-2-2 EN 60068-2-14
Operating and storage humidity	5 ÷ 85 % RH not-condensing	EN 60068-2-30
Vibrations	5 ÷ 9 Hz, 7 mm p-p 9 ÷ 150 Hz, 1 g	EN 60068-2-6
Shock	± 50 g, 11 ms, 3 pulses per axis	EN 60068-2-27
Protection class	Front panel IP66, Rear IP20	EN 60529
ELECTROMAGNETIC COMPATIBILITY (EMC)		
Radiated disturbance test	Class A	CISPR 22 CISPR 16-2-3
Electrostatic discharge immunity test	8 kV (air electrostatic discharge) 4 kV (contact electrostatic discharge)	EN 61000-4-2
Radiated, radio-frequency, electromagnetic field immunity test	80 MHz ÷ 1 GHz, 10V/m 1,4 GHz ÷ 2 GHz, 3 V/m 2 GHz ÷ 2.7 GHz, 1 V/m	EN 61000-4-3
Burst immunity test	± 2 KV dc power port ± 1 KV signal line	EN 61000-4-4
Surge immunity test	± 0,5 KV dc power port (line to earth) ± 0,5 KV dc power port (line to line) ± 1 KV signal line (line to earth)	EN 61000-4-5
Immunity to conducted disturbances induced by radiofrequency field	0.15 ÷ 80 MHz, 10V	EN 61000-4-6
Power frequency magnetic field immunity test	Enclosure, 50/60Hz, 30A/m	EN 61000-4-8
Voltage dips, short interruptions and voltage variations immunity test	Port: AC mains; Level:	
	100% duration:	1 cycle and 250 cycles (50Hz); 1 cycle and 300 cycles (60Hz);
	40% duration:	10 cycles (50Hz); 12 cycles (60Hz);
	70% duration:	25 cycles (50Hz); 30 cycles (60Hz);
	Phase: 0°-180°	
Test executed on the 230Vac side of the Gefran Soluzioni Srl Power Supply		EN 61000-4-11
	Port: DC mains; Level:	
	0% duration:	10ms 20 spaces by 1s
Test executed on the 24Vdc of the EUT		EN 61000-4-29

DURABILITY INFORMATION	
Backlight service life (LED type)	40000 Hrs. or more (Time of continuous operation until the brightness of the backlight reaches 50% of the rated value when the surrounding air temperature is 25°C) - see Note 1
SURFACE RESISTANCE	
Chemical resistance of the front glass for an exposure time of 24 hours without visible changes:	<ul style="list-style-type: none"> • Betadine (10% Povidone Solution) • Cola • Electrode Gel/Paste • Hydrogen Peroxide (3% Solution) • NaCl (0.9% Solution) • Coffee • Dextrose (5% Glucose Solution) • Hydrogen chloride (0.5% Solution PH=1) • Isopropyl Alcohol • Sodium Hypochlorit • Ethyl Alcohol (70%-90%) • Quaternary ammonium compound

Note 1: Extended use in environments where the surrounding air temperature is 40°C or higher may degrade backlight quality/reliability/durability.

4. TECHNICAL DATA

Model	G-Mation V45 070-5-00	G-Mation V45 101-5-00	G-Mation V45 156-5-00	G-Mation V45 215-5-00
System Resources				
Display - Colors	7 TFT 16:9 LED - 16M	10.1 TFT 16:9 LED - 16M	15.6 TFT LED - 16M	21,5 TFT LED - 16M
Resolution	800x480 WVGA	1280x800 WXGA	1366x768, HD	1920x1080, full HD
Brightness	500 cd/m ²		400 cd/m ²	300 cd/m ²
Dimming	Yes			
Touchscreen	True Glass Projected Capacitive, Multitouch			
CPU	64-bit RISC quad core - 1.6GHz			
Operating System	Linux			
Flash	4 GB			
RAM	2 GB			
FRAM	64 Kbytes			
Real Time Clock, RTC Back-up	Yes			
Interface				
Ethernet port	3 (port 0 - 10/100/1000, port 1 - 10/100, port 2 - 10/100)			
USB port	2 (Host V2.0, max. 500 mA)			
Serial port	1 (RS-232, RS-485, RS-422, software configurable). Max 3 serial ports using plug-in modules.			
SD card	Yes			
Buzzer	Yes			
Expansion	2 slot for plug in modules			
Ratings				
Power supply	24 Vdc (10 to 32 Vdc)			
Current Consumption	0.7 A at 24 Vdc (max.)	1.0 A at 24 Vdc (max.)	1.2 A at 24 Vdc (max.)	1.7 A at 24 Vdc (max.)
Battery	Rechargeable Lithium battery, not user-replaceable			
Input Protection	Electronic			
Environment Conditions				
Operating Temperature	-20° to +60 °C (vertical installation). Plug-in modules and USB devices may limit max temperature to +50 °C			
Storage Temperature	-20°C to +70°C			
Operating / Storage Humidity	5-85% RH, non condensing			
Protection Class	IP66 (front), IP20 (rear) Type: 12, 4X			
Operating Height	0 to 2000 m			
Dimensions and Weights				
Faceplate LxH	187x147 mm (7.36x5.79")	282x197 mm (11.10x7.80)	422x267 mm (16.6x10.5)	552x347 mm (21,7x13,66)
Cutout AxB	176x136 mm (6.93x5.35")	271x186 mm (10.67x7.32")	411x256 mm (16.18x10")	541x336 mm (21.30x13.22")
Depth D+T	47+8 mm (1.85+0.31")	56+8 mm (2.20+0.33)		56+8.5 mm (2.20x 0.33")
Weight	1.5 Kg	2.5 Kg	4.1 Kg	6.1 Kg
Approvals				
CE	Emission EN 61000-6-4, Immunity EN 61000-6-2 for installation in industrial environments			
UL	cULus: UL61010-1 / UL61010-2-201			
UL	cULus: Class 1 Div 2			

4.1. Dimensions

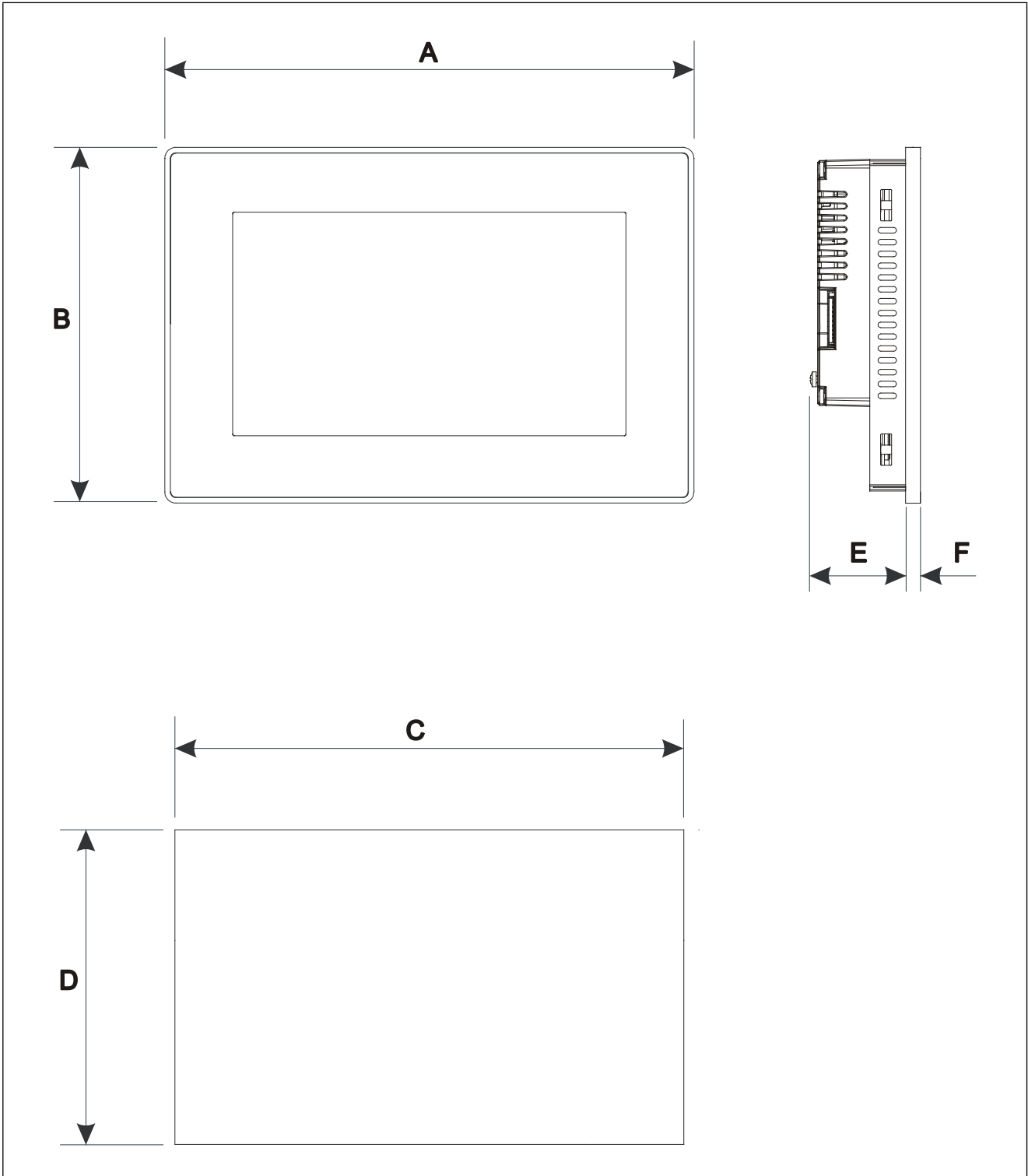

MODEL	A	B	C	D	E	F
G-Mation V45-070	187mm/7.36"	147mm/5.79"	176mm/6.90"	136mm/5.35"	47mm/1.85"	8mm/0.31"
G-Mation V45-101	282mm/11.10"	197mm/7.80"	271mm/10.67"	186mm/7.32"	56mm/2.20"	8mm/0.31"
G-Mation V45-156	422mm/16.60"	267mm/10.50"	411mm/16.18"	256mm/10.00"	56mm/2.20"	8mm/0.31"
G-Mation V45-215	552mm/21.73"	347mm/13.66"	541mm/21.30"	336mm/13.22"	56mm/2.20"	8mm/0.31"

4.2. Installation Environment

Avoid prolonged exposition to direct sunlight to avoid the risk of overheating the device.

The equipment is not intended for installation in contact with corrosive chemical compounds. Check the resistance of the front panel to a specific compound before installation.

Do not use tools of any kind (screwdrivers, etc.) to operate the touch screen of the panel.

In order to meet the front panel protection classifications, proper installation procedure must be followed:

- the borders of the cutout must be flat
- screw up each fixing screw until the bezel corner get in contact with the panel.
- the cutout for the panel must be of the dimensions indicated in this manual.

The IP66 is guaranteed only if:

- max deviation from the plane surface to the cut-out: $\pm 0.5\text{mm}$
- thickness of the case where is mounted the equipment: from 1,5mm to 6mm
- max surface roughness where the gasket is applied: $\pm 120\ \mu\text{m}$

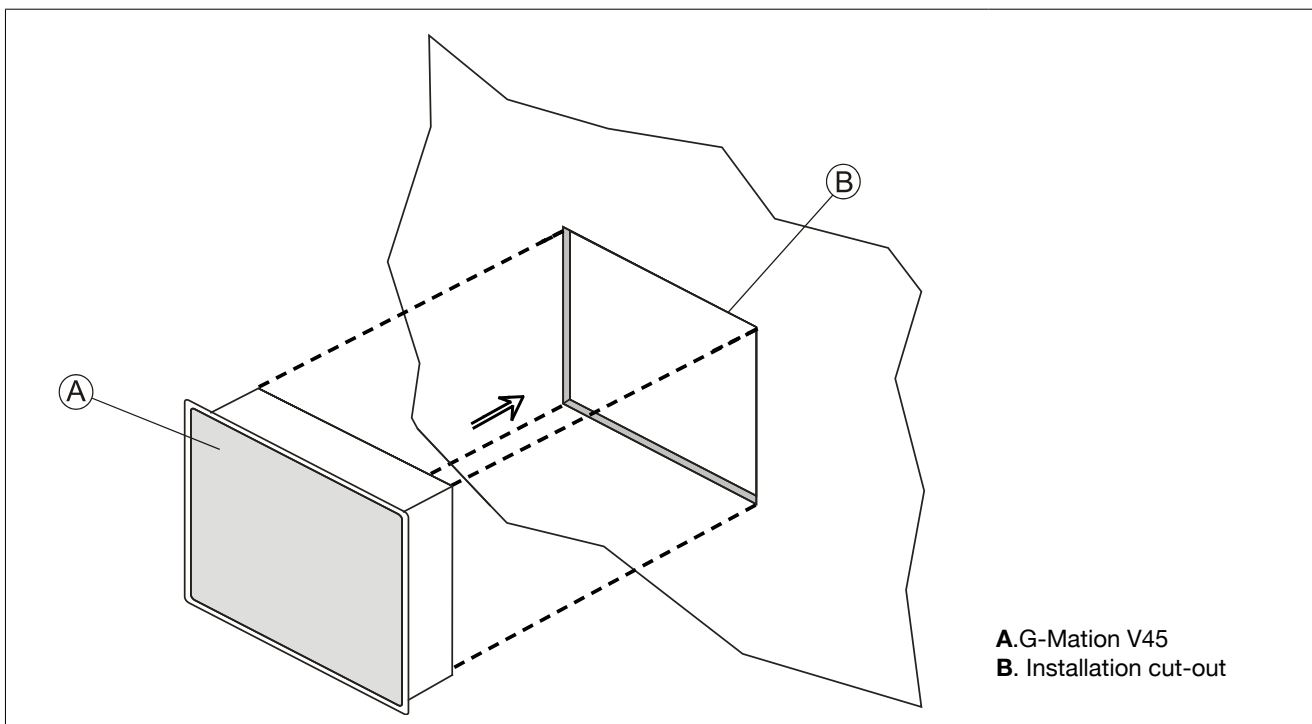

4.3. Safety instruction



For all installation notes, please refer to the Installation Guide provided with the product.

4.4. Installation Procedure

Place the fixing brackets contained in the fixing kit as shown in figure

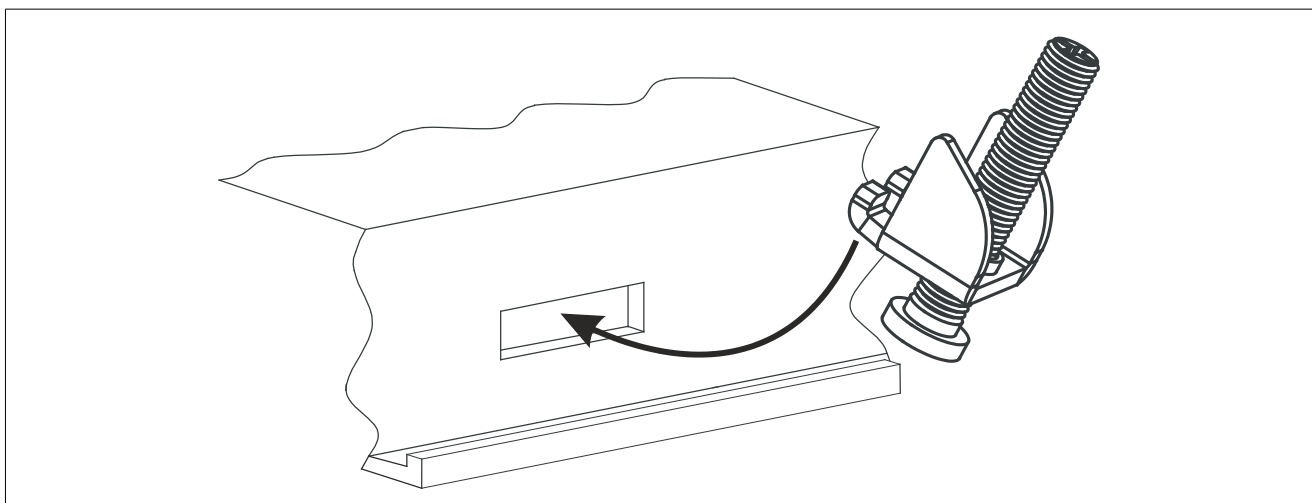

For all installation notes, please refer to the Installation Guide provided with the product.

5. CONNECTIONS

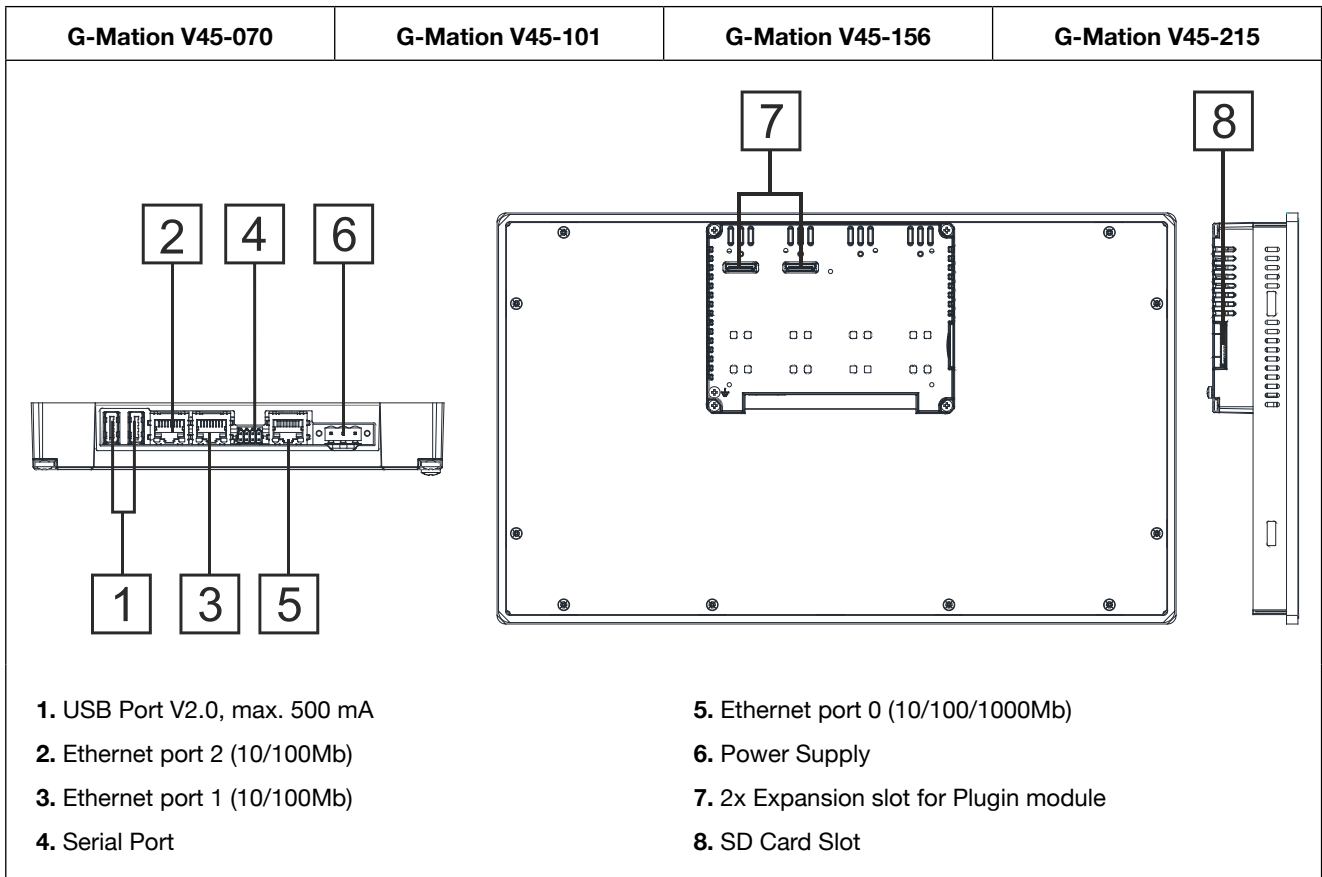
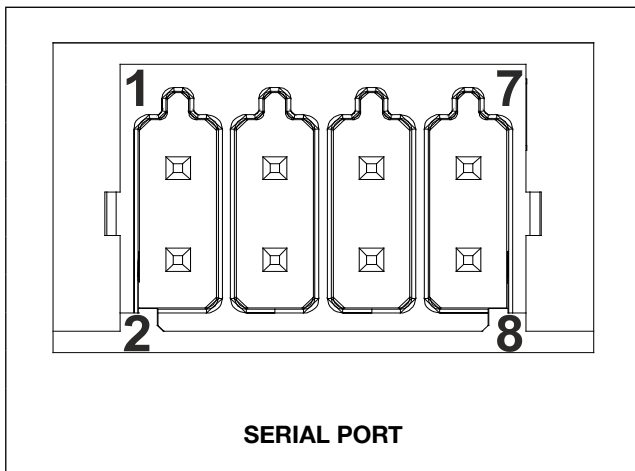

Figure 5.1

5.1. Serial Port

The serial port is used to communicate with the PLC or with another type of controller.
 Different electrical standards are available for the signals in the PLC port connector: RS-232, RS-422, RS-485.

The serial port is software programmable. Make sure you select the appropriate interface in the programming software..



RS-232		RS-422, RS-485	
Pin	Description	Pin	Description
1	RX	1	CHB-
2	TX	2	CHA-
3	CTS	3	CHB+
4	RTS	4	CHA+
5	+5V output	5	+5V output
6	GND	6	GND
7		7	
8	SHIELD	8	SHIELD
		To operate in RS-485 pins 1-2 and 3-4 must be connected externally.	

The communication cable must be chosen for the type of device being connected.

5.2. Ethernet Port

The Ethernet port have two status indicators. Please see description in figure.

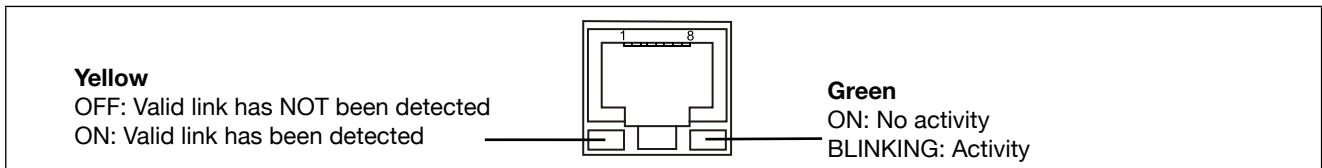

5.3. Optional plugin module

G-Mation V45 panels have several optional plugin module, multiple modules configurations are possible..

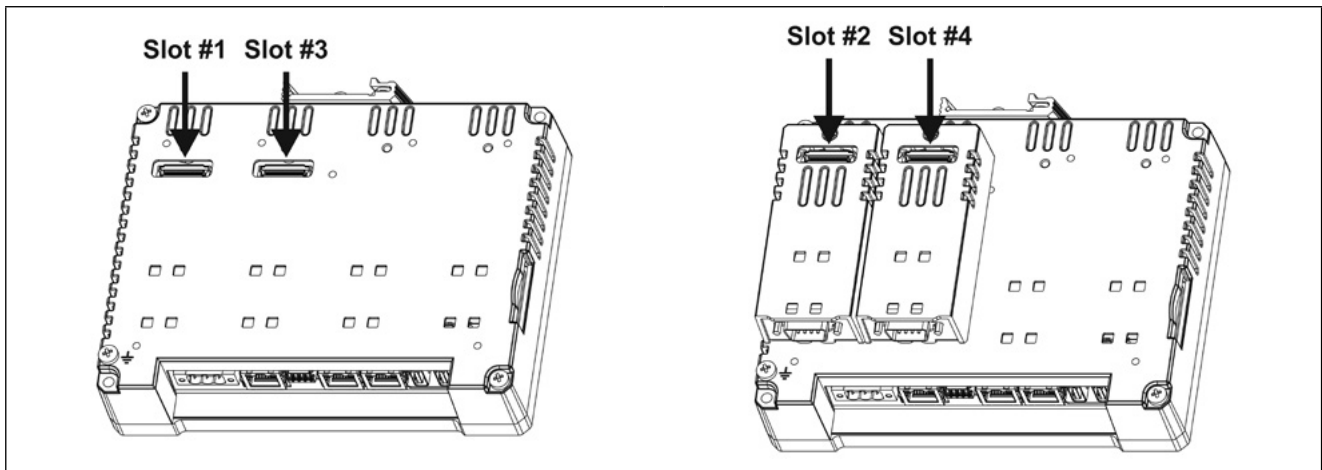

Slot#2 and Slot#4 are available only if plugin module has the “bus extension connector”.

Each slot carries three communication channels:

- 1 serial interface
- 1 CAN interface
- 1 2G/3G interface

Note: It is not possible to stack two modules that are using the same type of interface.

5.4. Optional plugin module installation procedure

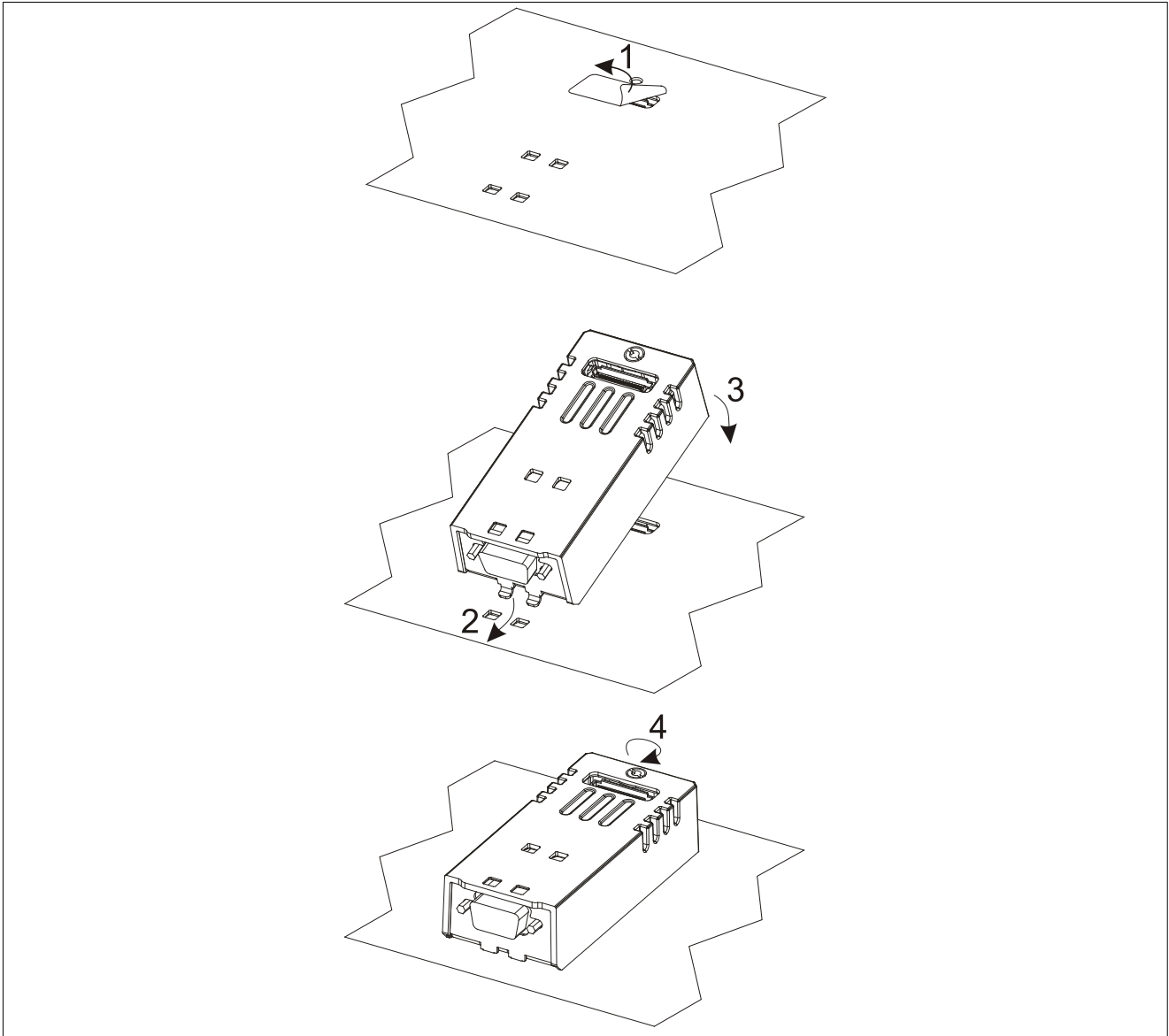

Below you can find relation between modules and max number of modules that can be used into G-Mation V45 e GF_Connect devices, based on their Interface Type:

Module	Application	Max Modules	Interface Type	Bus Extension connector
GV_PLUG-CAN	CAN	2	CAN	Y
GV_PLUG-3G	3G modem	1		Y
GV_PLUG-232	Serial RS232	2	Serial	Y
GV_PLUG-485	Serial RS485	2	Serial	Y
GV_PLUG-LTE_WIFI_GPS	4G wireless modem	1		Y

Max modules refers to max number of modules can be plugged into the HMI (all slots).

If you are planning to use GV_PLUG-232 and GV_PLUG-485 (additional serial ports) you will obtain following “COM - Slot#” association:

- a module plugged in Slot#1 or into Slot#2 will be COM2,
- a module plugged in Slot#3 or into Slot#4 will be COM3.

If you are planning to use two GV_PLUG-CAN (CAN interface) you will obtain following Slot# association:

- a module plugged in Slot#1 or into Slot#2 will be the CanPort 0,
- a module plugged in Slot#3 or into Slot#4 will be the CanPort 1.

A detailed description of Plugin modules can be found in the specific manual

6. POWER SUPPLY, GROUNDING AND SHIELDING

The power supply terminal block is shown in the figure below.

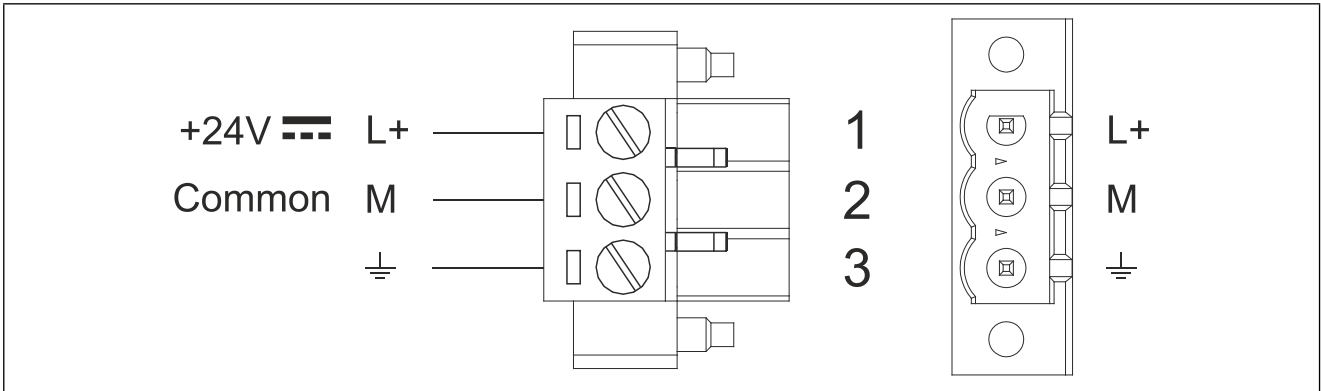

Figure 6.1

3 conductor 1,5mm² wire size minimum, minimum temperature conductor rating 105°C.

Note: Ensure that the power supply has enough power capacity for the operation of the equipment.

The unit must always be grounded to earth with 1,5mm² wire size minimum. Grounding helps limit the effects of noise due to electromagnetic interference on the control system. Earth connection will have to be done using either the screw or the faston terminal located near the power supply terminal block. A label helps identify the ground connection. Also connect to ground the terminal 3 on the power supply terminal block.

The power supply circuit may be floating or grounded. In the latter case, connect to ground the power source common as shown in figure (see below) with a dashed line. When using the floating power scheme, note that the panel internally connects the power common to ground with a 1MΩ resistor in parallel with a 4,7nF capacitor.

The power supply must have double or reinforced insulation. The suggested wiring for the power supply is shown below.

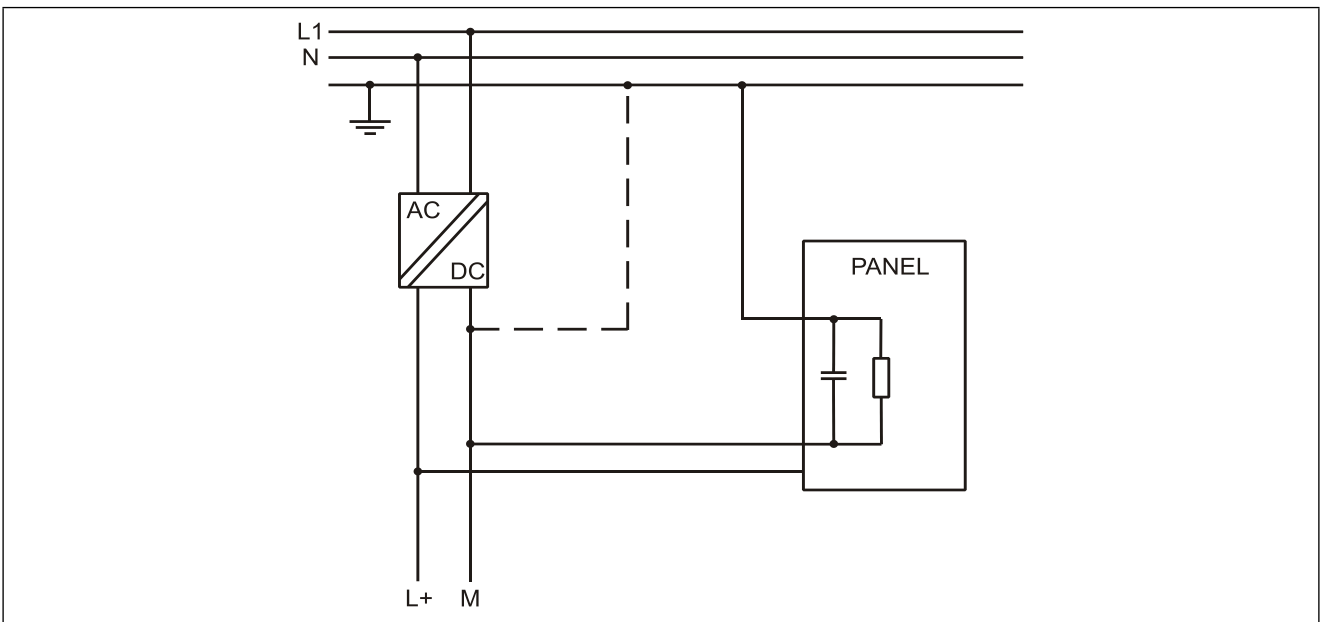

Figure 6.2

All the electronic devices in the control system must be properly grounded. Grounding must be performed according to applicable regulations.

7. BATTERY

These devices are equipped with rechargeable Lithium battery, not user-replaceable.

The following information is maintained by the battery:

- hardware real-time clock (date and time)

Charge:

At first installation must be charged for 48 hours.

When the battery is fully charged, it ensures a period of 3 months of data back-up at 25°C.

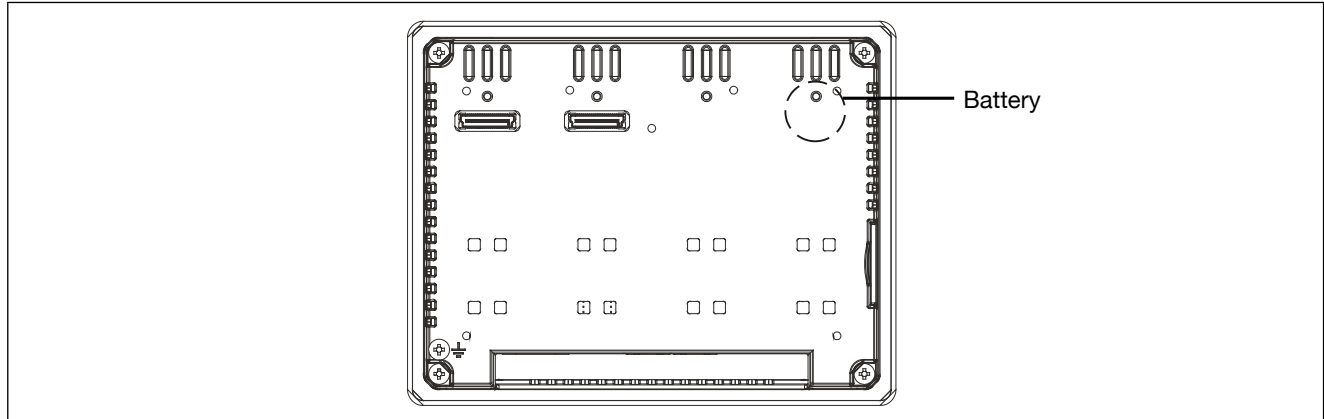

Figure 7.1: G-Mation V45-070, G-Mation V45-101, G-Mation V45-156, G-Mation V45-215



ATTENTION

Dispose of batteries according to local regulations.



ATTENTION

This device cannot be disposed of as a domestic waste but according to WEEE European Directive 2012/19/EU



8. SPECIAL INSTRUCTION FOR USE

- The equipment shall only be used in an area of not more than pollution degree 2, as defined in IEC/EN 60664-1.
- The equipment shall be installed in an enclosure that provides a degree of protection not less than IP 54 in accordance with IEC/EN 60079-15.
- Transient protection shall be provided that is set at a level not exceeding 140 % of the peak rated voltage value at the supply terminals to the equipment.
- Install the HMI device according to the accompanying installation instructions.
- Ground the HMI device according to the accompanying installation instructions.
- Only qualified personnel may install the HMI device or repair it.
- Ensure that the aeration holes are not covered.
- Care shall be taken not to allow layers of dust to form on the graphic panel in a way that might cause the accumulation of static charges. Keep the faceplate of the HMI device clean: the equipment must be cleaned only with a soft cloth and neutral soap product. Do not use solvents.
- This device should not be used for purposes and methods other than indicated in this document and in the documentation accompanying the product.

9. GETTING STARTED

G-Mation V45 devices products delivery configuration is based on a loader. Use the services of the loader to install applications on the device such as GF Designer HD or GF Project VX runtime.

GF Designer HD or **GF Project VX** are required, they are Gefran IDE software tools that must be properly installed on a computer running Microsoft Windows.

If you are planning to use your G-Mation V45 with Gf Project VX you must first initialize it using the **“System Settings**

menu” (see next chapter).

In **“Application”** menu select **“App Management”** and then **“install/update”**.

At this point you need the files **“ata0a.zip”** and **“ata0a.zip.md5sum”** contained in the GF project VX installation folder (C:\Gefran Automation Builder\GF_ProjectVX-4.x.x-64bit\ diskimages\install_zip\).

If you are accessing to system settings through a browser in your PC simply point at the files in the indicated folder.

If you are operating directly on the panel touch screen insert a USB key where you previously copied the files.

After proceeding with the installation procedure the panel needs to reboot and will be ready to download the application directly from GF Project VX.

If you are planning to use your G-Mation V45 with GF Designer HD there are two options to transfer a GF Designer HD runtime and application project to the device:

Ethernet

Connect the HMI device to the computer with an Ethernet network. In GF Designer HD select the command Run/Download to target. You may have to ensure that the proper firewall policy has been configured in the computer to allow GF Designer HD to access the network.

• USB

Create an Update Package using GF Designer HD and copy it to a USB Flash drive. Insert the USB key in the G-Mation V45 and proceed in "Application" menu as indicated for GF Project VX

10. SYSTEM SETTINGS

G-Mation V45 products have a system settings interface to allow configuration of system options. The user interface of System Settings is based on HTML pages accessible from the HMI screen or remotely using a Web browser using port 443.

To connect enter the address https:// IP/machine_config where IP is the IP address of the HMI device. Default username is "admin", default password is "Gefran123@". Use navigation menu on the left side of the screen to browse through the available options.

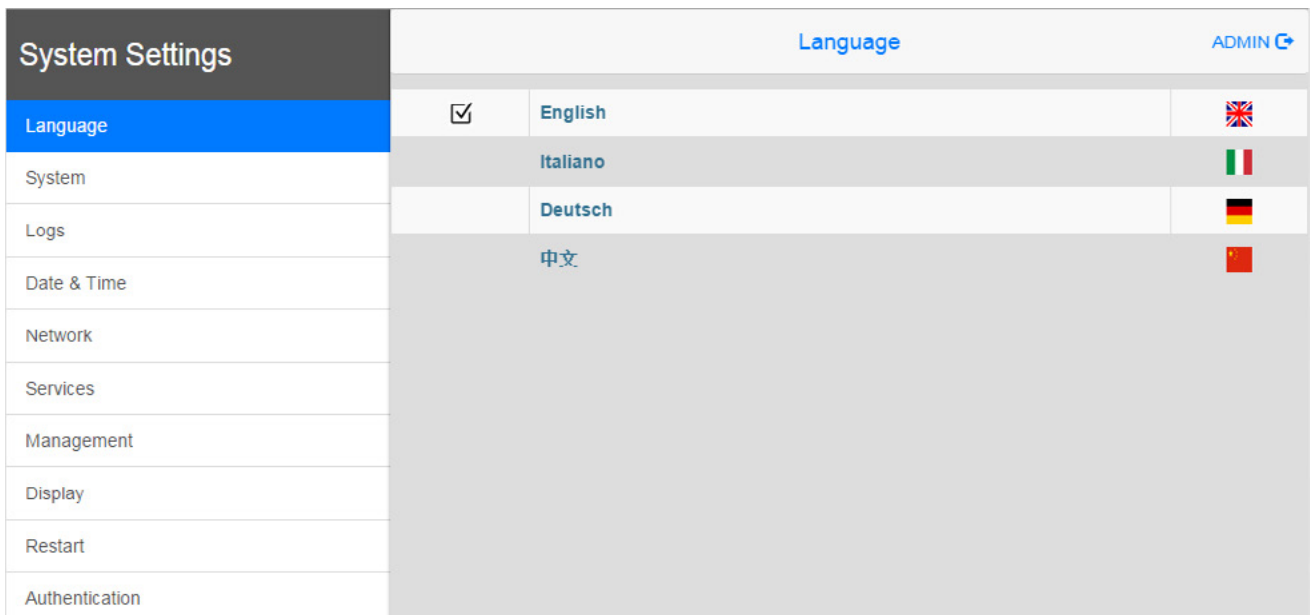

The active item of menu is highlighted on the left side of the screen. The right side shows related information and settings. Depending on the size of the HMI screen, both menu and content of selected item may be shown on screen at the same time or not.

System Settings has two modes of operation:

User Mode GF Designer HD runtime is running or the HMI device is in "factory default" status.

System Mode GF Designer HD runtime is not running or the HMI device has a software failure. System Mode includes all options available in User Mode and additionally includes commands dedicated to system upgrade and recovery not available when running in User Mode.

Activation of System Settings in **User Mode:**

Factory default status Press "System Setting" button on the HMI screen

GF Designer HD runtime running Recall context menu and select "System Settings". To recall the context menu click and hold any unused area of the touchscreen for a few seconds. Default hold time is 2 seconds.

Activation of Systems Settings in **System Mode:**

Normal operation If GF Designer HD runtime is not running: Press "System Setting" button on the device screen to recall System Settings in User Mode. Select "Restart" -> "Config OS" to reboot in System Mode.

If GF Designer HD runtime is running: recall context menu and select “System Settings”. To recall the context menu click and hold any unused area of the touchscreen for a few seconds. Default hold time is 2 seconds to enter in System Settings in User Mode. Select “Restart” -> “Config OS” to reboot in System Mode.

Recovery operation

If device is not responsive, use the so-called “tap-tap” procedure
 This procedure consists in tapping the surface of the touchscreen during the device power-up phase. Tapping frequency must be high.
 You have to start tapping the touchscreen as soon as power has been applied to the device. When the sequence has been recognized, the system shows the message: “TAP-TAP DETECTED”. At this point release touch to boot in User Mode without running GF Designer HD runtime or press and hold few seconds (selecting so “RESTART: CONFIG OS”) to boot in System Mode.

System Settings includes options for basic settings of the device:

- Language System** Configure language used for System Setting menu only.
 Show information about platform, status and timers (like System on time, backlight on time).
- Logs** Enable persistent log for BSP and allows exporting it.
- Date & Time Network** Change the device date and time, including time zone and NTP Server
 Configure IP Address of Ethernet interface and the other network settings like DNS, Gateway, DHCP, Hostname, routing and bridging.
- Services** Enable/disable services. Examples of services are: OpenSSH server, Bridge, Cloud, Router, SNMP and logging.
- Management** Update of BSP components (Main OS, Config OS, Boot loader, XLoader), check for partitions consistence, update of splash screen, information about usage and size of partitions. The update of Main OS is available only in System Mode, the update of Config OS is only in User Mode.
- Display** Adjust display brightness, configure automatic backlight turnoff and select HMI orientation (90°, 180°, 270° and 360°).

Restart Restart the device. “Main OS” option restarts the device in User Mode, “Config OS” option restarts the device in System Mode showing System Settings.

Authentication Configure password for administrator (“admin”) and for the standard user (“user”). Administrator has full access to System Settings (updates of BSP and other system components). Standard user has some limitations.

Note: Additional informations on System Settings are available in dedicated manual <https://www.gefran.com>

11. UNPACKING AND PACKING INSTRUCTIONS

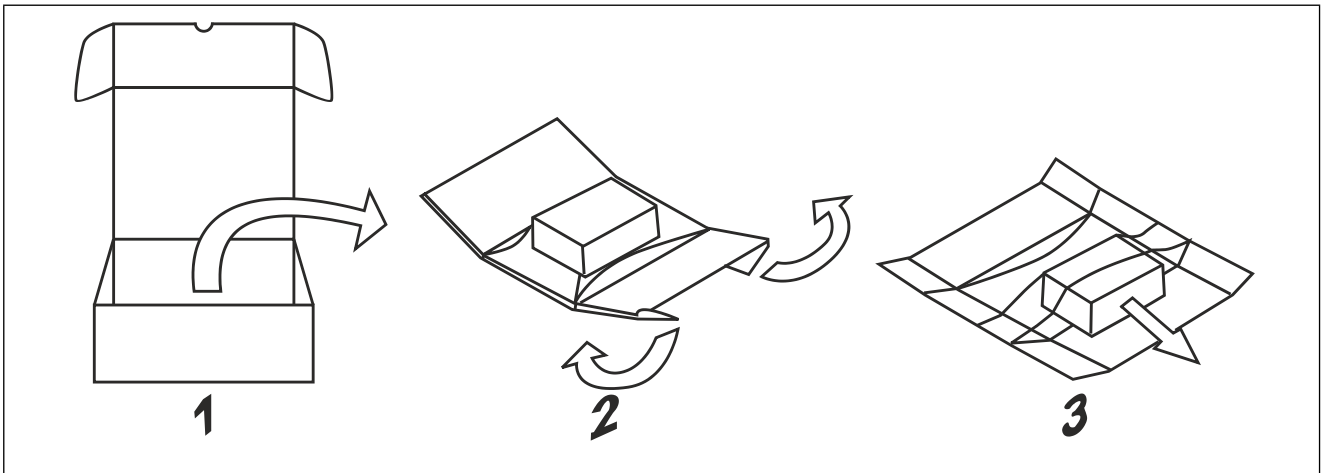

Figure 11.1: G-Mation V45 070, G-Mation V45 101

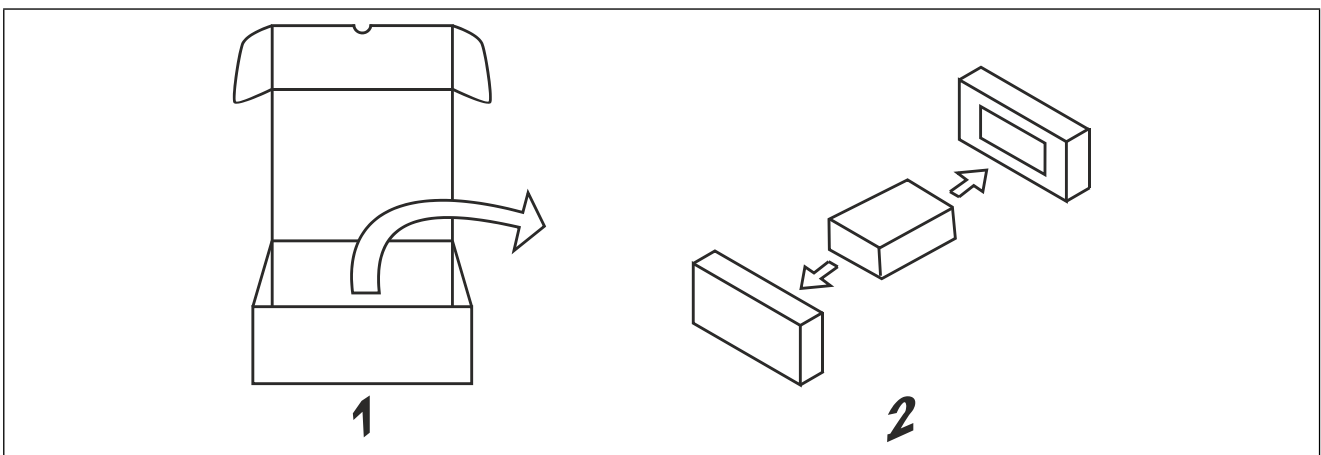

Figure 11.2: G-Mation V45 156, G-Mation V45 215

To repack the unit, please follow the instructions backwards.

GEFRAN

Gefran Soluzioni srl
Via Sebina 74 - 25050 Provaglio d'Iseo (BS) Italy
Tel. +39 0309888.1 - Fax +39 0309839063 - info@gefran.com
<http://www.gefran.com>
www.gefran.com/en/gefran-soluzioni